

CONTACTING US AND CUSTOMER SERVICES

World Headquarters

TEMPCO Electric Heater Corporation

607 N. Central Avenue • Wood Dale, IL 60191-1452 USA
Tel: 630.350.2252 • Toll Free: 800.323.6859 • Fax: 630.350.0232
E-mail: sales@tempco.com • Web: www.tempco.com

TEMPCO Mexico City

Tel: 52.55.2451.4070 • Fax: 52.55.5561.6889
Email: info@tempcomexico.com • www.tempcomexico.com

Tempco Branch Offices



Matt Kennedy — CA (Southern)
Anaheim, CA 92801
714.956.2209 Toll Free: 800.222.0807
Fax: 714.956.2136
Email: tempcal@att.net



Tom Thorpe — IN, KY
Jasper, IN 47546
317.809.7130
Email: tomthorpe@tempco-indy.com



Mike Harris — FL
Melbourne Beach, FL 32951
321.506.5990
Email: MikeHarris@tempcosales.com

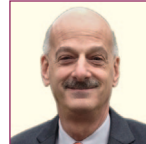

Joel Feder — MN, ND, SD, WI (Area Code 715)
Wayzata, MN 55391
612.810.2572 Fax: 952.417.6793
Email: jrfeder130@cs.com



Bob Brook — WA, AK, ID, OR, BC (Canada)
Bellevue, WA 98045
206.390.2679
Email: rsbrook@aol.com

**TEMPCO is represented Nationally & Internationally by factory Authorized/Trained Representatives & Distributors.
Contact information can be found at www.tempco.com**

Customer Services

Find the Heater or Accessory You Need Right Now Using Your PC to Access Tempco's Over 100,000 In-Stock Items

Tempco's finished product inventory is available for viewing on the web at www.tempco.com by clicking the **In-Stock Products** link. This inventory list is updated daily.

Need a Non-Stock and/or Custom Manufactured Product...

YESTERDAY?

Pronto Service is your answer to a crisis or emergency situation.



This service drastically reduces normal delivery times to meet the customer's needs on non-stock and custom manufactured products.

A Custom Terminated Cartridge Heater from Stock?



YES! Terminator offers 1 to 3 day delivery on custom terminated Hi-Density Cartridge heaters.

The Terminator lead assembly program takes a semi-finished stock heater and adapts it with one of the many terminations listed in this catalog. This termination process can be applied to our extensive inventory of over one thousand standard cartridge heater sizes and electrical ratings. Complete details can be found in Section 2, pages 2-12 through 2-21.

Terminator is the solution to your custom cartridge heater needs!

Flexible Credit Options

How to open an account:

Supply us with your company name, shipping and billing address and three industrial credit references where credit has been extended for over two years.

Open account to approved purchasers.

Terms are net 30 days from date of invoice.

We also accept the following major credit cards:



All purchases are subject to Tempco's Terms and Conditions of Sale. Additional information on pages 957 through 959.

GETTING TO KNOW US



Our Engineers, Sales Force, Customer Service Representatives, Accounting Department, Purchasing Department, Human Resources, Media Production Team, and Shop Manufacturing Supervisors with their more than 300 amazing Craftsmen, Salute You and Thank You for Trusting Us with Your Business.

TEMPCO'S COMMITMENT TO OUR CUSTOMERS

1 Superior Products. Tempco is dedicated to creating superior products for our customers through a passionate commitment to discover and utilize new technology. The core of our business is dedicated to providing complete engineering solutions in thermal components and thermal loop systems designed for

specific process heating applications. Our skilled engineers design customized solutions for a wide range of applications in many diverse industries worldwide. Many of our products are recognized and/or certified under third party approvals such as UL, CSA, and CE.

2 Expertise in engineering and manufacturing. As a company, we strive for our customers to view Tempco as their business partner. We meet the challenges of industry either by simplifying the completion of a new project or improving upon a trouble-



some existing application. Ongoing change is inevitable and our industry is demanding and fast paced. Tempco is at the forefront of addressing the challenges of original equipment manufacturers (OEMs) and maintenance (MRO) applications.

Turn the Page to View Tempco's Entire Product Line in the Pictorial Index



900+ Pages of
15 Major Product Sections
Highlighted in **39** Pages

See Pages **A-4** through **A-42**.

Engineering



Section 16 contains engineering information pertaining to process heating, temperature sensing and control, plus useful reference data.

Part # Prefixes



An alphabetical index of Part Number Prefixes on pages 954 through 956 identifies catalog page numbers of particular products.

Pictorial Index

Band Heaters

Used to heat cylindrical surfaces and available in several construction styles to perform under different operating environments.

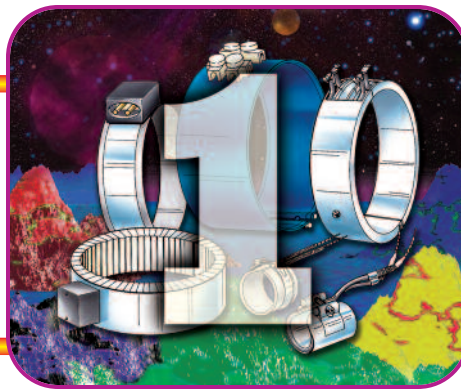

Catalog Pages
1-1
through
1-94

Mi-Plus[®] *Mi-Plus (mineral insulated) Band Heaters*

See Pages 1-2 through 1-23

Mineral insulated heater assembly is formed under pressure to a precise diameter with a thin low-mass cross section, assuring fast heat-up rates and reduced cycle times.

PERFORMANCE RATINGS

Max. Sheath Temperature: 1400°F (760°C)

Nom. Watt Density:

Nozzle Bands
under 3" diameter: 30-100 W/in² (4.7-15.5 W/cm²)

Barrel bands

3" and greater in diameter: 20-70 W/in² (3.1-10.9 W/cm²)

Max. Watt Density:

150 W/in² (23 W/cm²)

Dependent on heater size, operating temperature and termination.

Special Features:

High Temperature and High Watt-Density Capabilities



Duraband[®] *Duraband Mica Band Heaters*

See Pages 1-24 through 1-59

A mica insulated heater incorporating a Low Thermal Expansion Alloy outer sheath that is used as a uniquely designed Built-In Strap.

PERFORMANCE RATINGS

Max. Sheath Temperature: 900°F (482°C)

Nom. Watt Density: 20-45 W/in² (3-7 W/cm²)

Max. Watt Density:

Dependent on heater size and operating temperature.

Special Features:

Most Economical, Versatile and Commonly Used Band Heater



Rectangular Band
See page 1-47

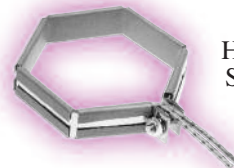

Hexagon Band
See page 1-47



Custom Engineered/Manufactured Mica Insulated Heaters for Specific Applications

See Page 1-49

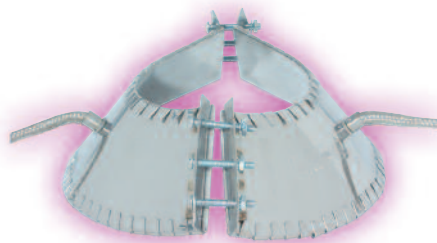
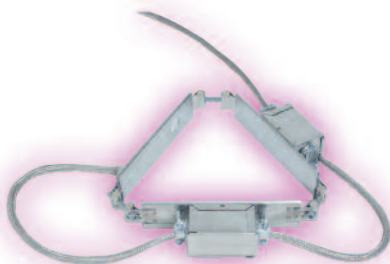

Ceramic Band

Ceramic Band Heaters

See Pages 1-60 through 1-77

Ceramic Band Heaters consist of a helically wound resistance coil made from nickel-chrome wire precisely strung through specially designed ceramic insulating bricks, forming a flexible heating mat.

PERFORMANCE RATINGS

Max. Sheath Temperature: 1400°F (760°C)

Nom. Watt Density:
20-45 W/in² (3-7 W/cm²)

Max. Watt Density: 45 W/in²

Special Features:

Fully Flexible Ceramic Fiber Insulated Heater Conserves Electrical Energy.

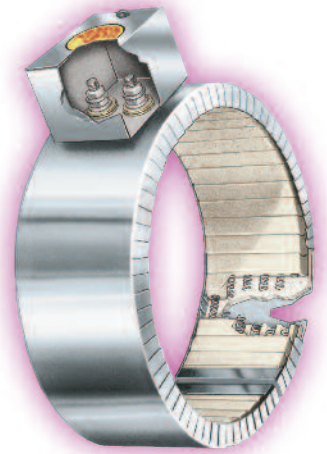

Tubular Band

Tubular Nozzle Band Heater

See Pages 1-78 and 1-79

Tubular Band Heaters are recommended for heating applications where premature nozzle band heater burn-out on plastic injection molding machines is a constant problem due to contamination from plastic overflow or other contaminants.

PERFORMANCE RATINGS

Max. Sheath Temperature: 1000°F (540°C)

Nom. Watt Density: 45 W/in² (7 W/cm²)

Max. Watt Density: 45 W/in²

Special Features:

Rugged Contamination-Proof Construction

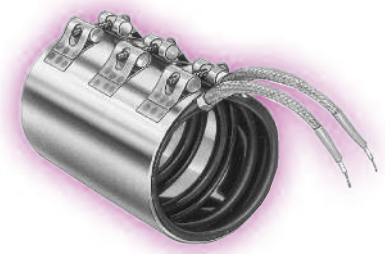

Maxiband®

Maxiband® Heaters

See Pages 1-80 through 1-94

The channels in the specially designed extruded aluminum track have been precisely sized to accept a .315 diameter tubular heating element, and provide an excellent heat sink for rapid heat transfer and good temperature uniformity.

PERFORMANCE RATINGS

Max. Temperature: 650°F (350°C)

Nom. Watt Density: 35 W/in² (5.4 W/cm²)

Max. Watt Density: 45 W/in²

Special Features:

Rugged Contamination-Proof Construction with Excellent Heat Transfer

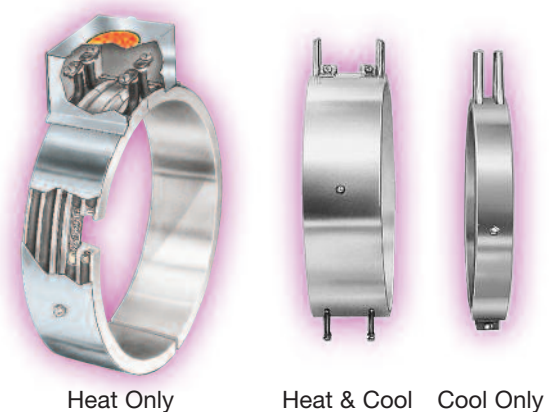

Heat Only

Heat & Cool Cool Only

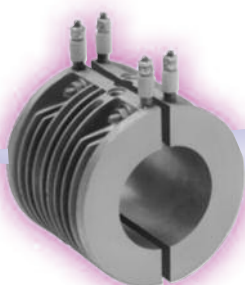

Cast-In Band Heaters are in Section 3



Cartridge Heaters

Section 2

Cartridge heaters are typically inserted into drilled holes to heat platens and molds or used as liquid immersion heaters.



Catalog Pages
2-1
through
2-62

2 CARTRIDGE HEATER TYPES – Hi-Density (HDC) and Low Density (LDC)

See pages 2-39 through 2-60 to Select the Cartridge Heater Termination(s) and/or Option(s) Best Suited for Your Application

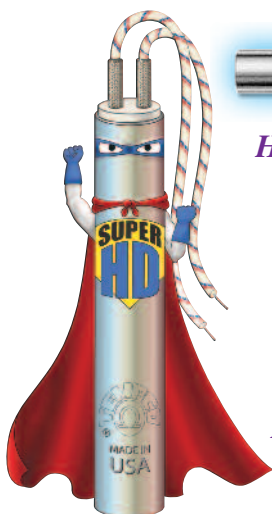

Hi-Density Cartridge Heaters

See Pages 2-2 through 2-27

Swaged Construction
for Applications
up to 1400°F (760°C)

Hi-Density Cartridge Heaters in Metric Sizes

See Pages 2-28 through 2-33



Low Density Cartridge Heaters

See Pages 2-34 through 2-38

A Quality and Economical Heater,
Used in Applications Requiring
Lower Operating Temperatures
and Watt Densities

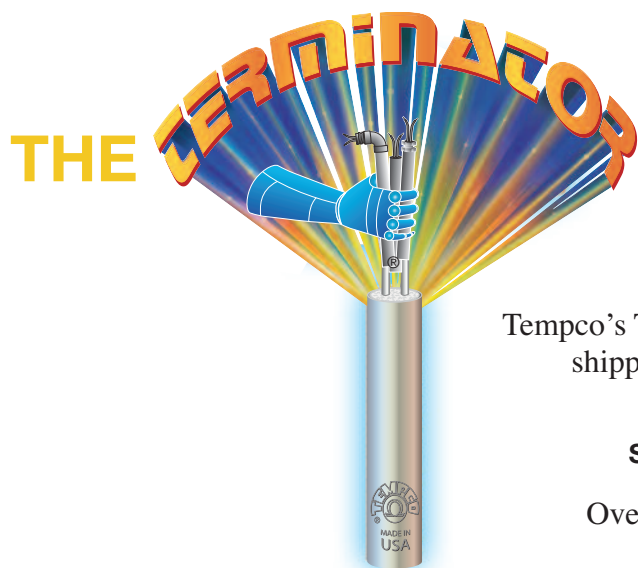
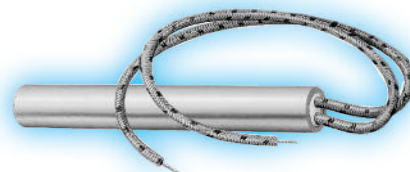

STOCK ADVANTAGE...

Custom Terminated Hi-Density Cartridge Heaters ON DEMAND!

Tempco's Terminator Lead Conversion Program guarantees **1 to 3 day** shipping on custom terminated Hi-Density Cartridge Heaters.

Select from **19** Lead Terminations and Options.
See Quick Reference Charts on Pages 2-12 and 2-13.

Over **1000** Standard Sizes and Electrical Ratings In Stock.
See Pages 2-14 through 2-21.

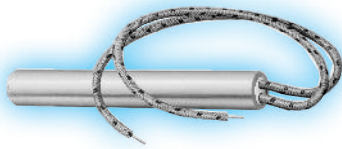

Stock Cartridge Heaters with Flexible Leads
See Page 2-22



Hi-Density Cartridge Immersion Heaters
See Page 2-23

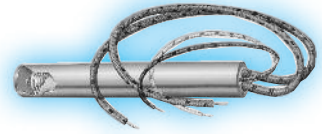

Stock Hi-Density Pennybottom™ Cartridge Heaters with Type J Thermocouple and Flexible Leads
See Pages 2-24 through 2-26



OEM Replacement Cartridge Heaters
See Page 2-27



BNS Anti-Seize Cartridge Heater Coating
See Page 2-7

LDA and HAC Forced Air Process Cartridge Heaters
See Page 2-60

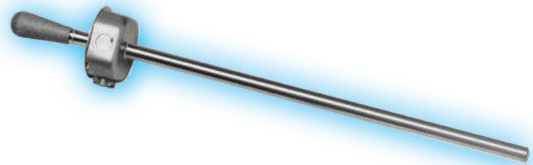

Hi-Density Bolt Heaters
See Pages 2-61 and 2-62

Highly Engineered Custom Manufactured Specific Use Cartridge Heaters
See Pages 2-8 and 2-9

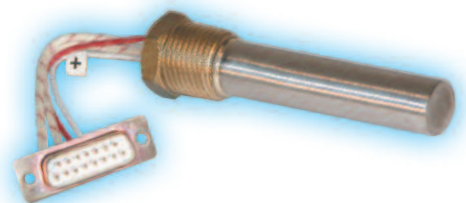
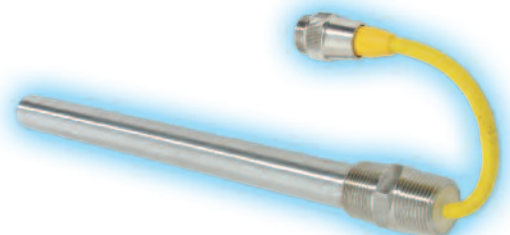
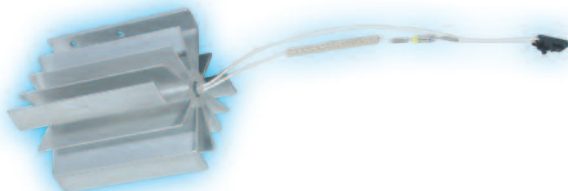
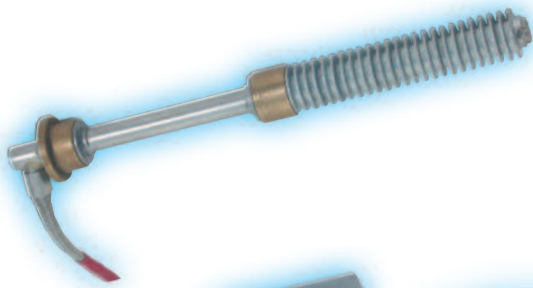

Cast-In Heaters

Used in plastic processing, food warming, semiconductor manufacturing and other industries. Available in aluminum and bronze alloys.

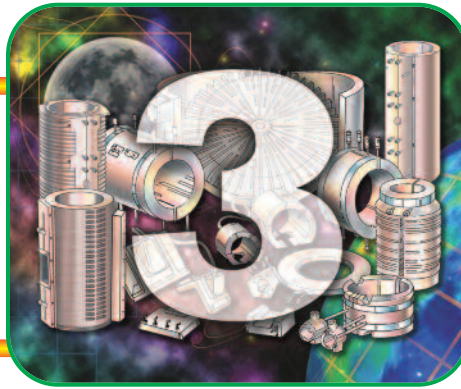

Section 3

Catalog Pages
3-1
through
3-74

Custom Manufactured Special Purpose Cast-In Heaters

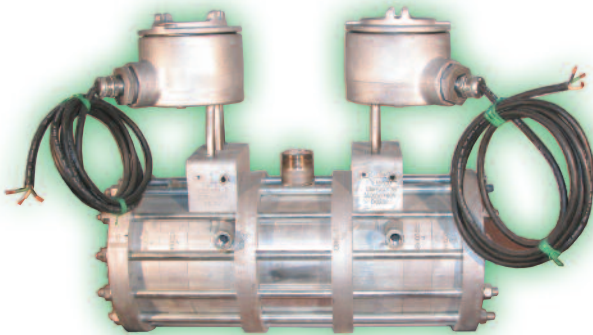

*Complex Geometric Cast-In Heaters
for Diversified Industries*
See Pages 3-2 through 3-8

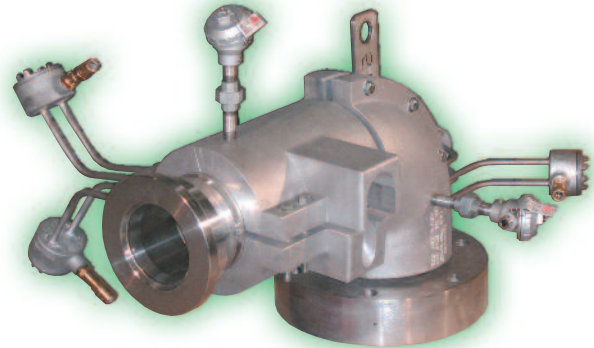

*Cast-In Heaters
for Transfer/Feed Pipes*
See Page 3-9

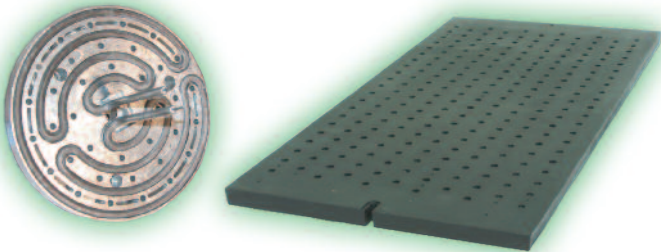

*Cast-In Heaters for
Semiconductor Manufacturing*
See Page 3-10

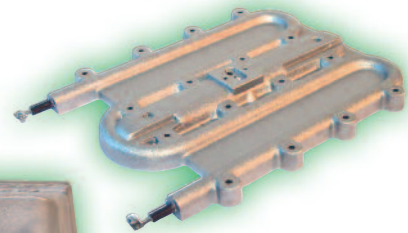

*Cast-In Heaters for the
Food Service Industry*
See Page 3-11



*Series CHX-100, CHX-200 and CHX-300
Circulation Heaters*
See Pages 3-12 through 3-17

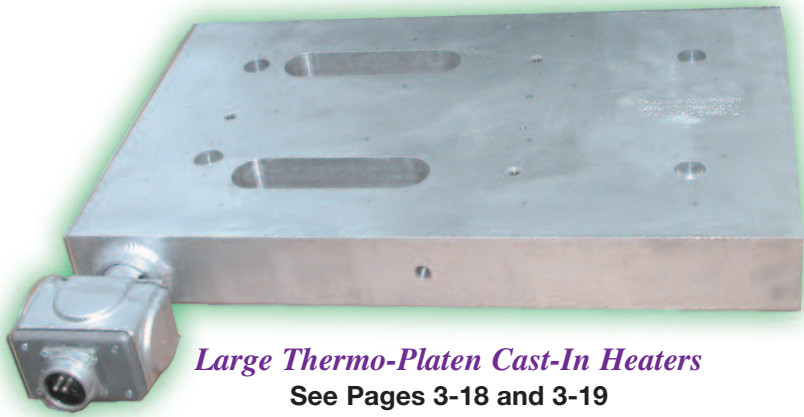

Large Thermo-Platen Cast-In Heaters
See Pages 3-18 and 3-19

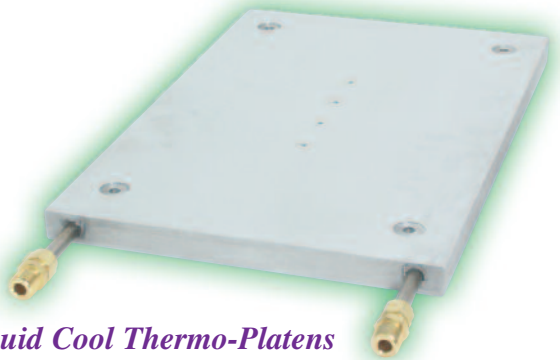

Liquid Cool Thermo-Platens
See Pages 3-18 through 3-23

Cast-In Heaters for Plastics Processing Equipment

Three Heating and Air-Cooled Shroud Systems

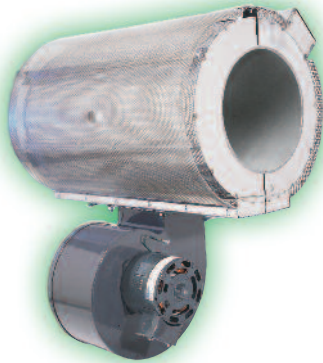

Cool TO-THE Touch™
Hi-Efficiency Extruder
Heating & Cooling Systems
See Pages 3-29 through 3-32

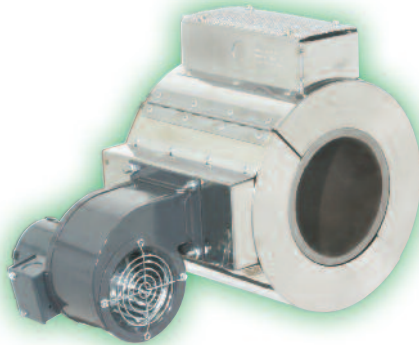

Multi-Versal
Construction Heating &
Cooling Systems
See Pages 3-33 through 3-36



Arctic Cast®
Hi-Efficiency Extruder
Heating & Cooling Systems
See Pages 3-37 through 3-40

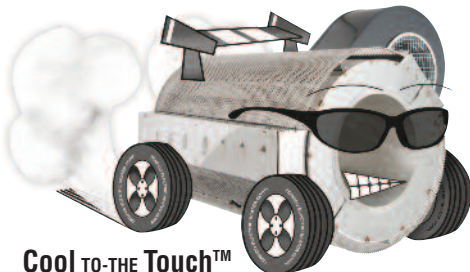

Cool TO-THE Touch™
Out-Performs Other Extruder Barrel
Heating & Cooling Products.



Forced Air Blowers for
Air-Cooled Heating Systems
See Pages 3-41 through 3-43

CONTINUED

Cast-In Heaters for Plastics Processing Equipment



*Air-Cooled Finned
Cast-In Heaters*
See Pages 3-44 through 3-47

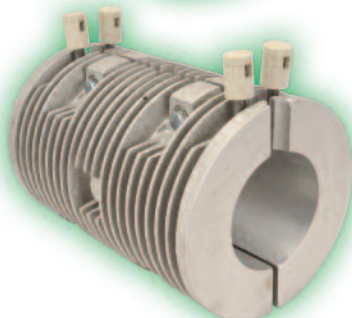

Liquid-Cooled Cast-In Heaters
See Pages 3-48 through 3-63

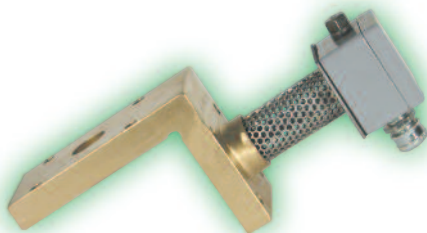

*“L” Shaped Cast-In Heaters for
Square & Rectangular Extruder Barrels*
See Pages 3-64 and 3-65

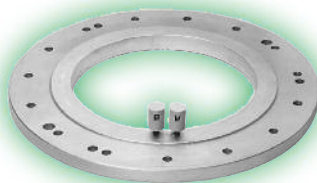

Cast-In Ring Heaters
See Page 3-68



Cross Head Die Heaters
See Page 3-69



Cast-In Aluminum Die Heaters
See Page 3-70 and 3-71

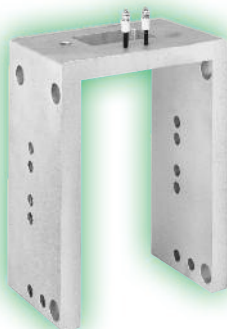

Special Shapes
See Pages 3-72 and 3-73

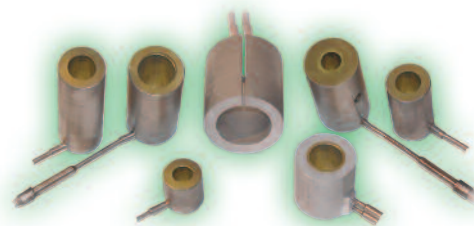

*Cast Bronze Nozzle Heater Bushings
for Runnerless Molding*
See Section 5, page 5-28

Ceramic Fiber Heaters

Heat source combined with a high temperature insulation for operating temperatures up to 2012°F/1100°C. Higher temperature ratings, up to 2192°F/1200°C are available with a limited number of designs.



Section 4

Catalog Pages
4-1
through
4-8

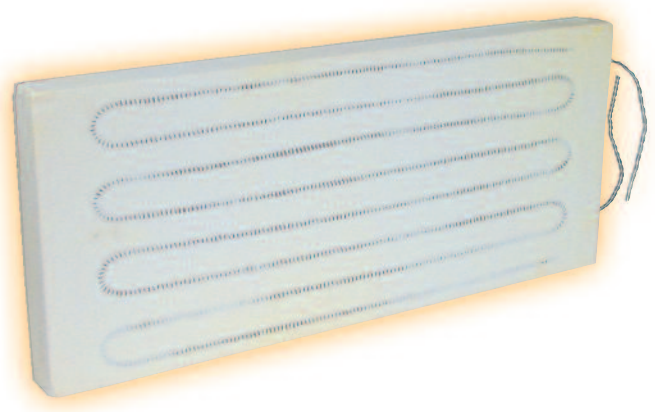

Flat Panel Heaters
See Page 4-6

Flat Panels		
Width:	4", 6", 8"	± 1/8"
	10" through 32"	± 1/4"
Length:	6"	± 1/8"
	12" through 44"	± 1/4"
Thickness:	1"	± 1/8"
	2" through 4"	± 1/4"



Ceramic Fiber Cylindrical Heaters
See Page 4-7

Full Cylindrical		
I.D.:	0.75" through 4"	± 1/8"
	5" through 18"	± 1/4"
O.D.:	3" and 3.5"	± 1/8"
	5" through 24"	± 1/4"
Length:	6"	± 1/8"
	12" and 18"	± 1/4"

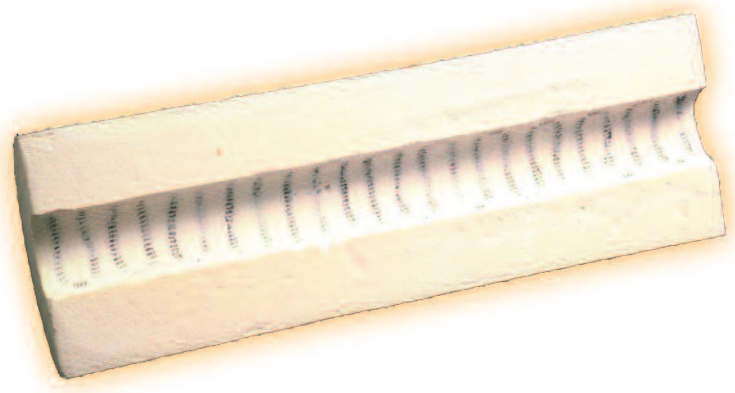

Ceramic Fiber Semi-Cylindrical Heaters
See Page 4-8

Semi-Cylindrical		
I.D.:	1", 2" and 3.5"	± 1/8"
	5" through 18"	± 1/4"
O.D.:	5" through 22"	± 1/4"
Length:	6"	± 1/8"
	12" through 36"	± 1/4"

Coil & Cable Heaters

Section 5

The flexibility of mineral insulated cable allows the Mightyband™ heater to be coiled, formed, wrapped around pipes or used straight. It can also be cast-in to metal or welded onto machine component parts.



Catalog Pages
5-1
through
5-30



Mightyband Coil Heaters with Built-in Thermocouple

See Pages 5-2 through 5-9

Tempco's introduction of the Mightyband Heater in 1977 offered the plastic injection molding industry a more effective heating system to be placed in their products. Today, Tempco offers many options to meet customer specifications.

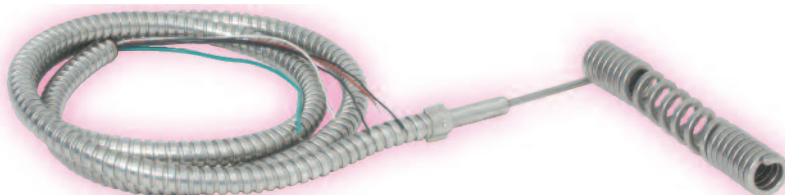

OEM Replacement Heaters for Hot Runner Systems

See Pages 5-11 through 5-14

Direct Replacement square and rectangular cable heaters.

Mightyband Coil Heaters with Square MI Cable

See Page 5-10

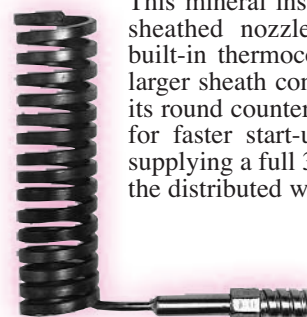

This mineral insulated square-sheathed nozzle heater with built-in thermocouple offers a larger sheath contact area than its round counterpart, allowing for faster start-up cycles and supplying a full 360° of heat to the distributed wattage coil.

Oxygen Analyzer Heaters

See Page 5-15

Inconel® 600 Seamless Nickel Alloy Sheath Material for process temperatures up to 1400°F (760°C).



Tempco-Pak Cable Heaters

See Pages 5-16 through 5-23

The densely compacted MgO insulation used in Tempco-Pak heaters produces excellent high temperature insulation resistance and dielectric strength.



Sinuated (Formed) Tempco-Pak Heater Cables

See Page 5-16

Forced Gas or Air Tempco-Pak Heaters

See Page 5-16

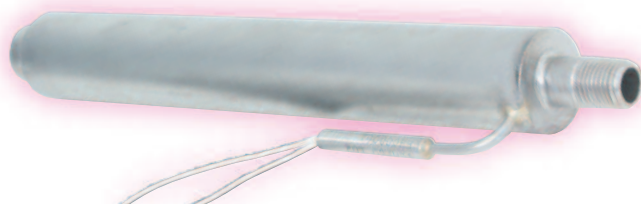

Star Wound Coil Tempco-Pak Heaters

See Page 5-16

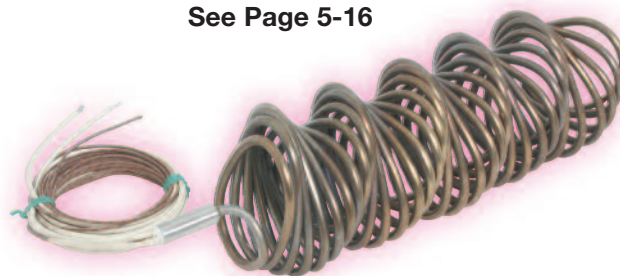



.125 & .153 Diameter Cable Heaters
With and Without Thermocouples
 See Page 5-20

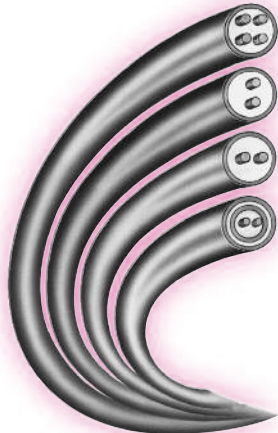

Bulk Round Heater Cables
 See Pages 5-24 and 5-25

Typical Applications

- * Blown Film Die Heaters
- * Heat Tracing
- * De-icing Car Wash Door Rails
- * De-icing Outside Stairways

Mini Coil Heaters for OEM
Hot Runner Systems
 See Pages 5-26 and 5-27

Mini Coil Band Heaters are designed and manufactured under the tightest tolerances so that they may be used in hot runner/runnerless injection mold tooling with complete confidence in maintaining the manufacturer's original balanced heating.

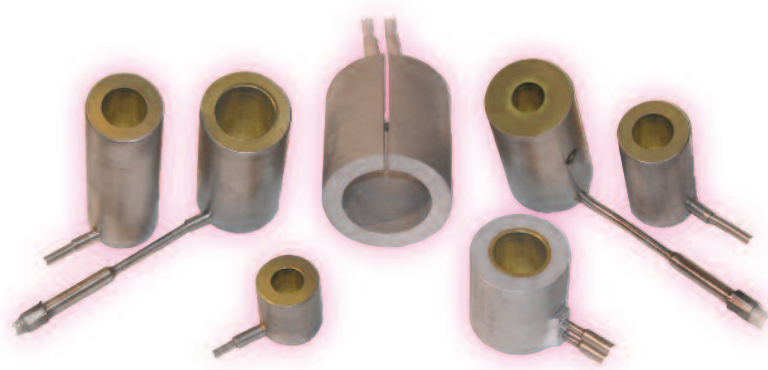

Cast Bronze and Aluminum
Nozzle Heater Bushings
 See Pages 5-28 and 5-29

Cast bronze nozzle heater bushings eliminate uneven temperature profiles and short heater life, and with their precision machining, also eliminate poor fit and the need for clamping bands while providing maximum heat transfer.



Gamma Series Dual Sleeve Mini Coil Heater
 See Page 5-30

Gamma Series mini coil heaters for hot runner tooling are constructed with the heating element tightly sandwiched between a nickel plated copper inner sleeve and a stainless steel outer sleeve.

Heat Trace Cable

Section 6

Heat trace cables are used to counteract the effects of heat loss from process piping systems.



Catalog Pages
6-1
through
6-14

Constant Wattage Heating Cables are all parallel resistance, low watt density electrical heaters designed to be cut to the desired lengths in the field, eliminating the need for prefabrications and reducing or eliminating many design and installation costs.

KE Style Constant Wattage Heat Trace Cable

Maximum Temperature: 500°F (260°C)

See Pages 6-8 and 6-10



FE Style Constant Wattage Heat Trace Cable

Maximum Temperature: 400°F (204°C)

See Pages 6-9 and 6-10



Self Limiting Heating Cable is a low watt density parallel circuit electrical heater. The multi-stranded bus wires are extruded in an irradiated self-regulating conductive polyolefin that increases and decreases its heat output with changes in the ambient temperature.

SL Style Self-Limiting Heat Trace Cable

Maintains Temperatures up to 150°F (65°C)

See Pages 6-11 and 6-12



Heat Trace Temperature Controls

See Page 6-13

Closed Cell Elastomeric Insulation

See Page 6-14



Infrared Heaters

Section 7

Infrared radiant heat energy can be delivered to concentrated areas at a very fast rate with individual heaters or arrays.



Catalog Pages
7-1
through
7-102

Solid Curved Face Ceramic Infrared E-Mitters® Series CRL, CRB, CRM, CRC and CRS

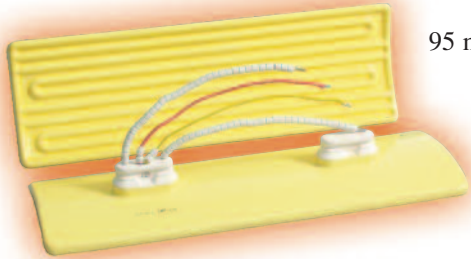

Series CRL

95 mm × 295 mm (3.72" × 11.63")

See Page 7-3

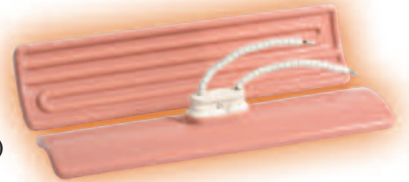

Series CRB

60 mm × 245 mm (2.36" × 9.65")

See Pages 7-4 and 7-5



Series CRM

60 mm × 163 mm (2.36" × 6.41")

See Page 7-6



Series CRC

60 mm × 122 mm (2.36" × 4.80")

See Pages 7-7 and 7-8



Series CRS

60 mm × 60 mm (2.36" × 2.36")

See Page 7-8

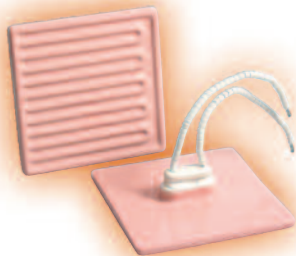

Solid Flat Face Ceramic Infrared E-Mitters® Series CRG

122 mm × 122 mm (4.80" square)

See Page 7-9

Insulated Flat Face Ceramic Infrared E-Mitters®

See Pages 7-10 and 7-11

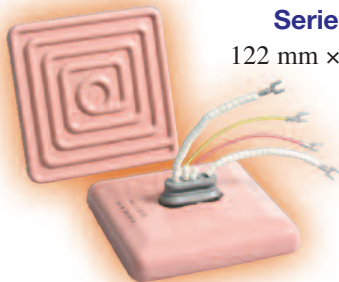

Series CRH Short Neck

122 mm × 122 mm (4.80" × 4.80")



Series CRD Long Neck

122 mm × 122 mm (4.80" × 4.80")

CONTINUED →

Insulated Flat Face Short Neck Ceramic Infrared E-Mitters® Series CRN and CRZ

See Pages 7-12 and 7-13

Series CRN

60 mm × 245 mm (2.36" × 9.65")

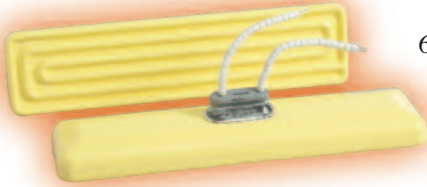

Series CRZ

60 mm × 122 mm (2.36" × 4.80")



CRA Linear Structural Housings

See Pages 7-15 through 7-19



E-Mitter Accessories

See Pages 7-14 and 7-20 through 7-23

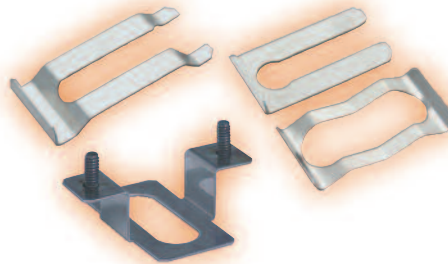
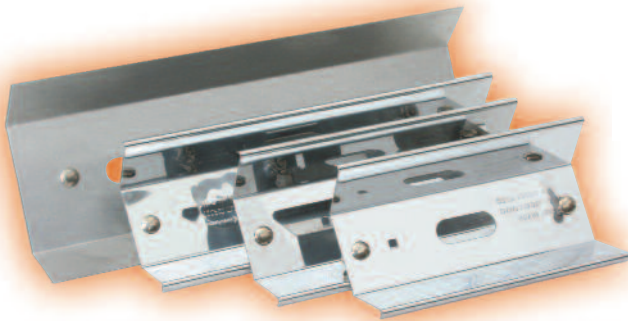

CRP 12" × 12" Modular Panels

See Pages 7-24 through 7-27

Design Features

- * *Standard colors are metamorphing yellow and traditional white.*
- * *Low noise type K thermocouple mounted internally in center heater.*
- * *Standard operating temp range: 750 to 1300°F*
- * *2.5 to 6µm infrared radiation wavelength*

ARA Arrays Assemblies See Pages 7-28 through 7-37

Design Features

- * Custom array housings and large multiple panel arrays designed to fit your thermoforming or wide area infrared heating application
- * For use with any style ceramic E-Mitter, quartz mini-tube E-Mitter or quartz tubular elements
- * Heater wattage, voltage and column/row spacing customized to meet your specifications
- * Can be factory wired with companion control panels for ease of installation
- * Suitable for use in horizontal or vertical orientations

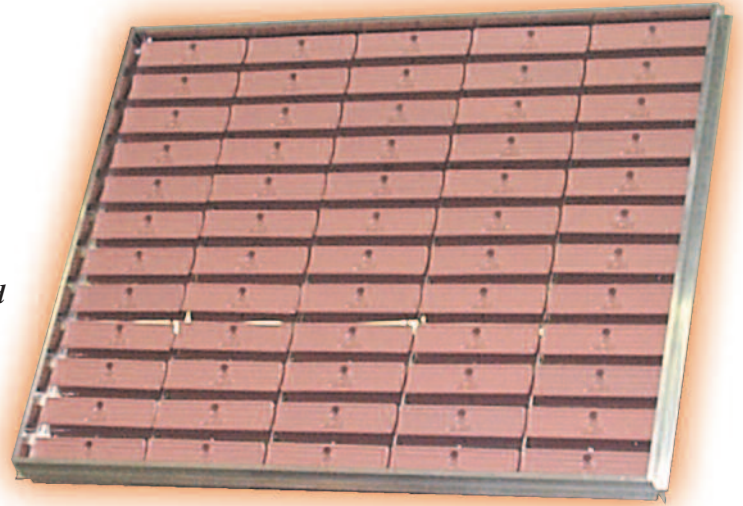

Edison Style Screw-In Bulb Ceramic Infrared E-Mitters Series CRE, CRR and CRT



CRE Series
See Pages 7-38 and 7-39



CRR Series
See Page 7-39



CRT Series
See Page 7-40

Ceramic E-Mitters Enclosures Series EHC See Page 7-41

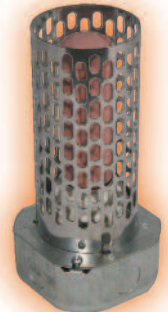

KTE & KTG Series High Intensity Quartz Mini-Tube Infrared E-Mitters See Pages 7-42 through 7-47

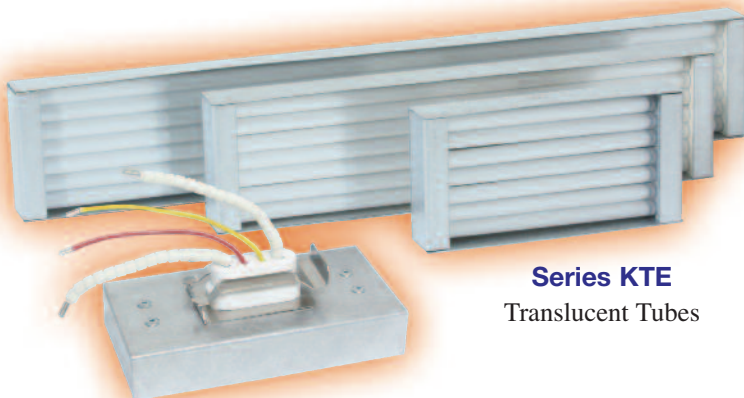

Series KTE
Translucent Tubes

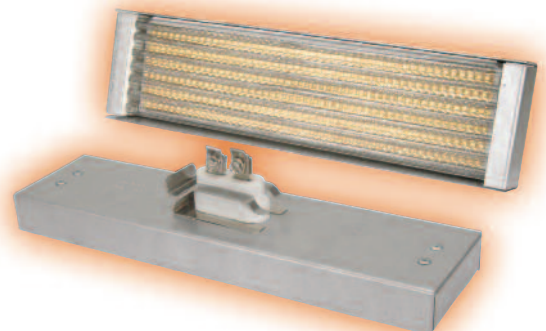

Series KTG
Clear Tubes with Gold Coated
Ceramic Backing

CONTINUED →

KTE & KTG Series High Intensity Quartz Mini-Tube Infrared E-Mitters Assemblies



CRA Linear Array Assemblies

See Page 7-47



ARV Array Assemblies

See Pages 7-48 through 7-51

Sealed IR Quartz Lamps
See Pages 7-52 through 7-55



Series QRH Sealed Quartz Lamp Radiant Heater Assemblies

See Pages 7-56 and 7-57



VS Glow Infrared Heaters

See Pages 7-58 through 7-61

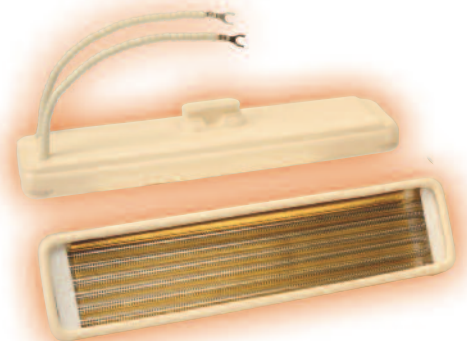
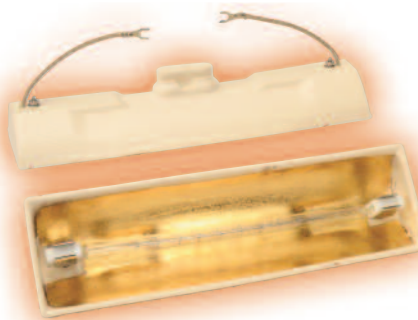
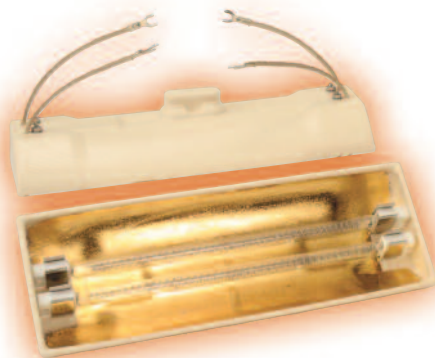

Series VSA

- * Short Wave IR
- * Tungsten in Halogen-Filled Lamp
- * All Ceramic Housing Construction
- * Gold Coated Ceramic Reflector

Series VSC

- * Medium Wave IR
- * Star-Wound Tungsten in Evacuated Lamp
- * All Ceramic Housing Construction
- * Gold Coated Ceramic Reflector

Series VSR

- * Medium Wave IR
- * Fe-Cr-Al Resistance Wire in Air
- * All Ceramic Housing Construction
- * Gold Coated Ceramic Reflector



Gemini Twin Bore Infrared Heater & Assemblies

See Pages 7-62 through 7-69

Design Features

- * Industry Standard Twin Bore Quartz Tube Formats
- * 24-karat Gold Back Coating for Targeted Infrared Applications
- * White Ceramic Reflective Back Coating for Extreme Temperature Requirements

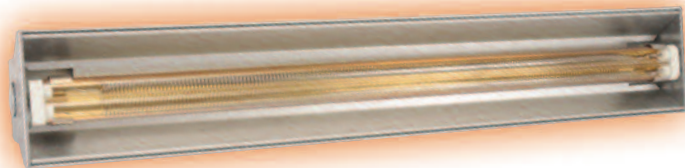

CRA Linear Gemini Arrays



ARG Gemini Arrays

Series KRD Quartz Tubular Elements

See Pages 7-70 and 7-71



Series KRH Linear Assemblies with Series KRD Quartz Tubular Elements

See Pages 7-72 and 7-73



Universal 2000 Series Metal Sheathed Tubular Radiant Heaters

See Pages 7-74 through 7-87



Infrared Radiant Panels

See Pages 7-88 through 7-95

Design Features

- * Available in four emitter face styles
- * Maximum Watt Densities from 25 to 40w/in²
- * Panel can be mounted in any direction
- * Uniform Infrared Heating Coverage

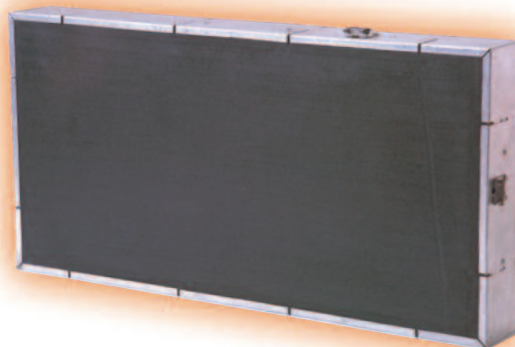

Useful Technical Information On Infrared Heating

See Pages 7-96 through 7-102

Strip Heaters

Section 8

Used in the surface heating of tanks, as the heat source in industrial ovens and for heating air and other inert gases.



Catalog Pages
8-1
through
8-26

Channel Strip Heaters
See Pages 8-2 through 8-11

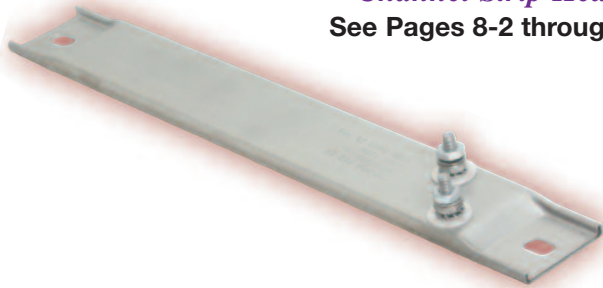

Finned Channel Strip Heaters
See Pages 8-12 through 8-15

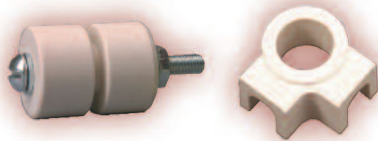
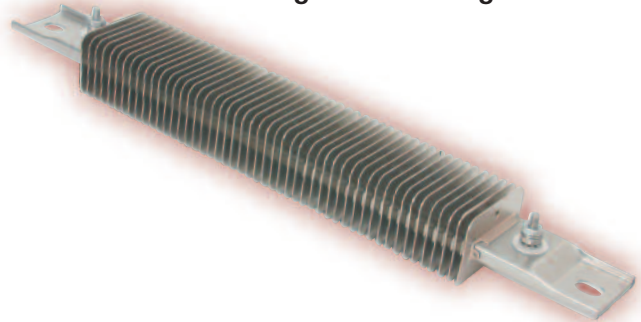

Stock Ceramic Accessory Items
See Page 8-13



Cabinet Enclosure Heaters
See page 8-15



Type ARC Channel Strip Radiant Heater Arrays
See Page 8-10

Maxistrip Heaters
See Pages 8-16 through 8-19

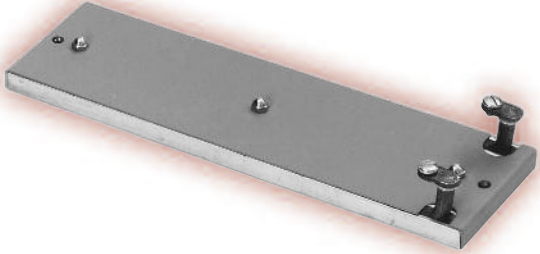

Mica Insulated Strip Heaters
See Pages 8-20 through 8-25

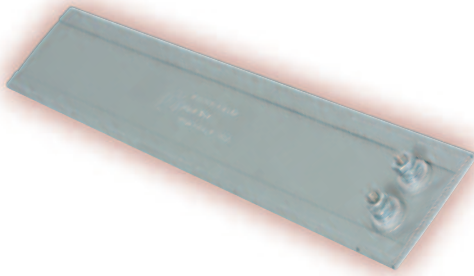

Custom Engineered/Designed Mica Insulated Strip Heaters
See Page 8-26

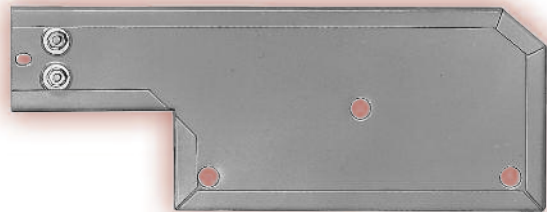
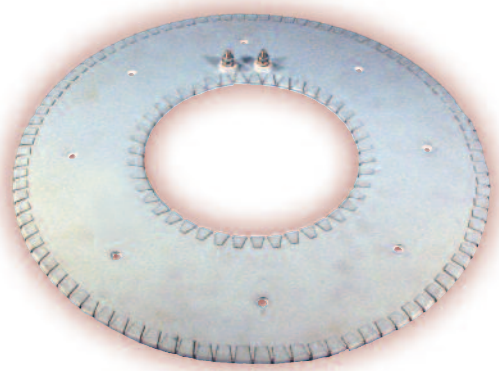

Non-Metal Sheath Custom Mica Heaters
See Page 8-26

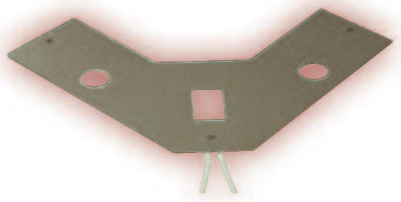

Flexible Heaters

Used in food service equipment, guidance systems, laminators and many other applications.

Section 9

Catalog Pages
9-1
through
9-32



Silicone Rubber Heaters

See Pages 9-2 through 9-7 and 9-9 through 9-21

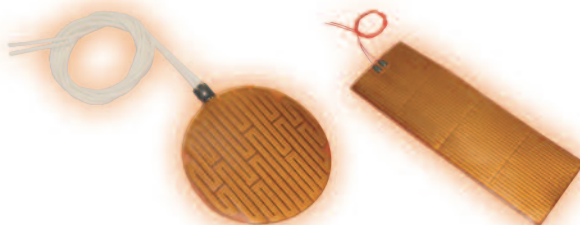

Kapton® Heaters

See Pages 9-4 and 9-8



PVC Pipe/Conduit Bending Heaters

See Page 9-17

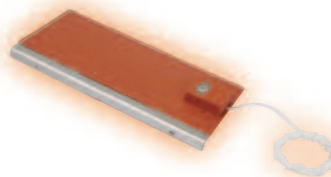

Enclosure Heater

See Page 9-18

Composite Cured Heater Blankets

See Page 9-19



Drum Heaters

See Pages 9-20 and 9-21





Foil Heaters
See Page 9-23



Fiberglass Insulated and Tubular Sheathed Rope Heaters
See Pages 9-24 and 9-25

Flexible Heating Tapes
See Pages 9-26 and 9-27



Flexible Duo-Tape®
See Pages 9-28 and 9-29

Silicone Rubber Duo-Tape®
See Page 9-30

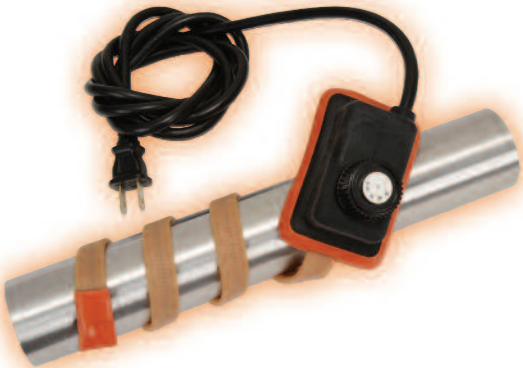
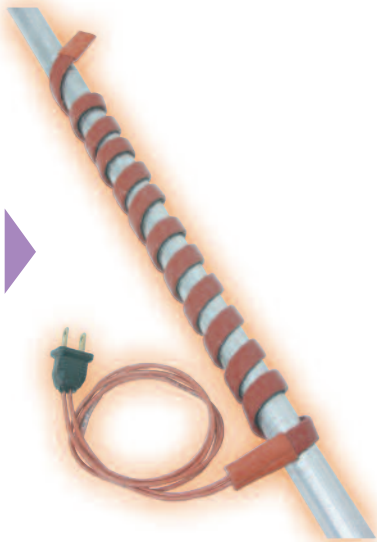

Silicone Rubber Heating Tapes with Thermostat
See Page 9-31

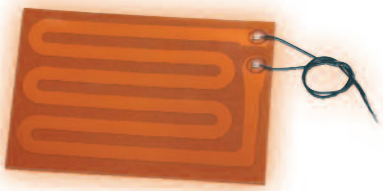

Printed Thick Film Heating Elements
See Page 9-32

Tubular Heaters

Section 10

Available in several diameters, lengths and sheath materials; can be formed into virtually any shape, brazed or welded to any metal surface.



Catalog Pages
10-1
through
10-18



Tubular Heaters
See Pages 10-2 through 10-12

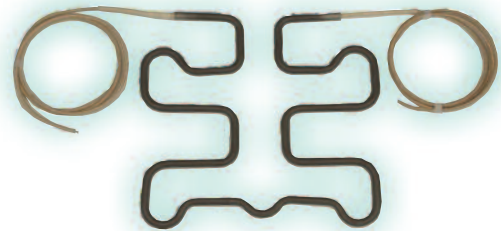

Tubular Heaters for Runnerless Molds
See Page 10-13



Straight Tubular Heaters
See Pages 10-14 and 10-15



*Finned Tubular Heaters &
Single-Ended Tubular Heaters*
See Page 10-16



Custom Tubular Heaters
See Page 10-17

Type ART Tubular Radiant Heater Arrays
See Page 10-17

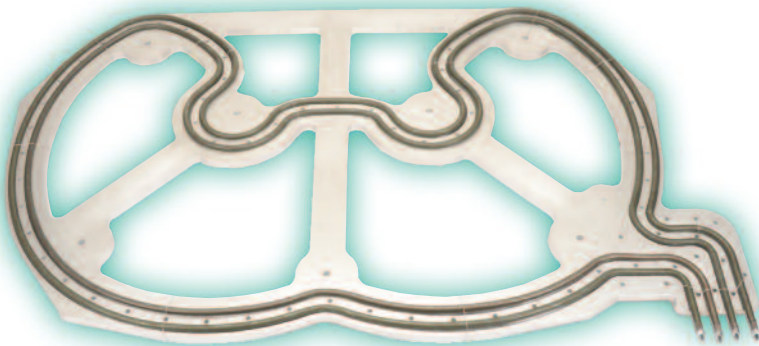

Process Heaters

Section 11

Basic liquid immersion heaters to highly engineered turnkey process circulation heating systems.

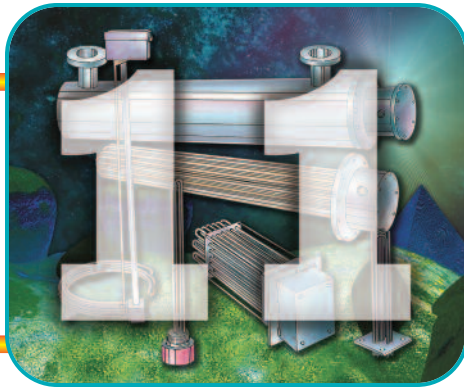

Catalog Pages
11-1
through
11-128

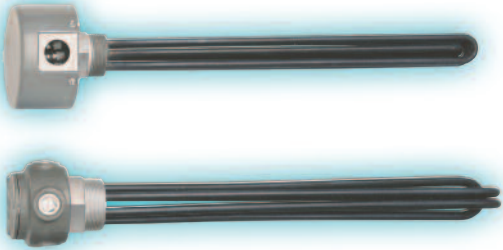

Screw Plug Immersion Heaters
See Pages 11-2 through 11-19



Thermostats
See Pages 11-6 through 11-10



◀ *Stock Copper Element
Screw Plug Immersion Heaters*
See Page 11-17

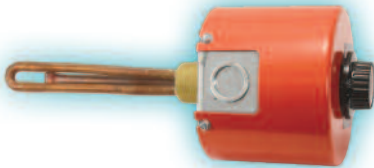
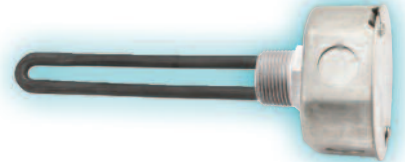

*Stock Incoloy Element
Screw Plug Immersion Heaters* ▶
See Page 11-18

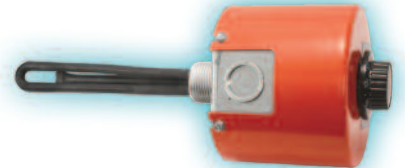

*Self-Contained
Immersion Heaters*
See Page 11-19



Hot Water Tank Heaters
See Page 11-19

Type FAH Aluminum Finned Heaters
See Page 11-20

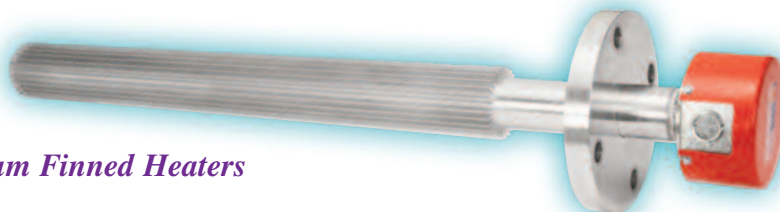

CONTINUED →

Flanged Immersion Heaters for Plastics Processing and Other Industries

See pages 11-22 through 11-25

The various style heaters listed in stock are direct replacements for heaters in many OEM applications.

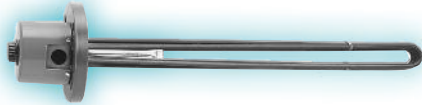
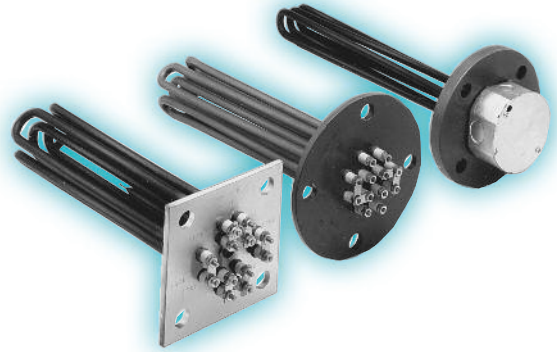

Flanged Immersion Heaters

See Pages 11-26 through 11-44

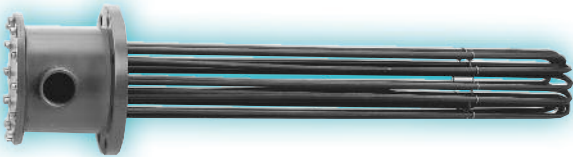
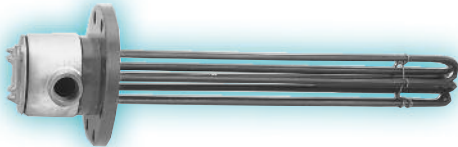

Sanitary Process Solutions Heater

See Page 11-45



Circulation Heaters

See Pages 11-46 through 11-69

Circulation Heaters consist of Screw Plug or Flanged Immersion Heaters, depending on kilowatt rating and size, mated to a pressure vessel.

Mightybooster™ In-Line Circulation Heaters

See Page 11-70

Mightybooster™ in-line heaters consist of a thermostatically controlled 1-1/4" steel or brass screw plug heater mounted in a pressure vessel and are ideal for low kilowatt applications.



Series CHX-100, CHX-200 and CHX-300 Circulation Heaters

See Pages 3-12 through 3-17 in Section 3

Stainless tubing is cast into an aluminum body which acts as a heat exchanger.





Turnkey Standard & Custom Process Heating Systems
See Pages 11-71 through 11-73

LDA In-Line Forced Air Process Heaters
See Pages 11-74 and 11-75

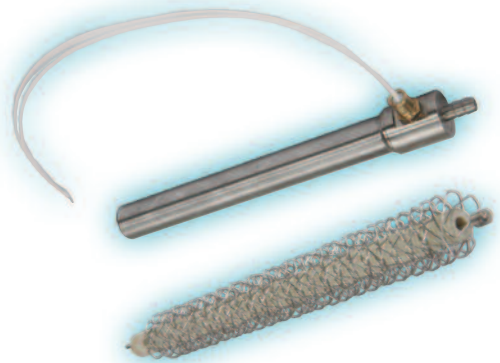

HAC In-Line Forced Air Process Heaters
See Pages 11-76 through 11-77



Tank Heaters See Pages 11-78 through 11-81

CONTINUED 

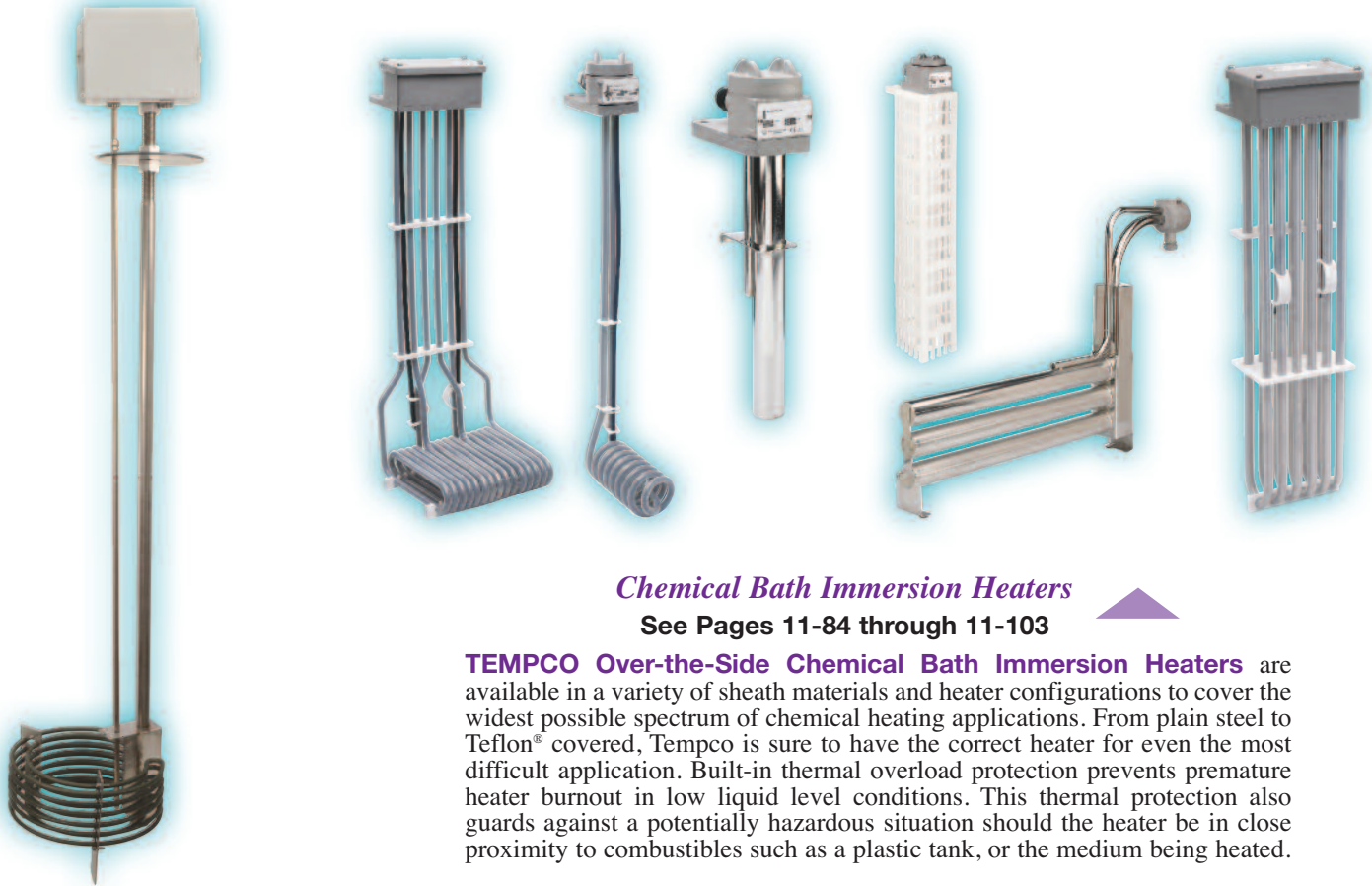

Chemical Bath Immersion Heaters

See Pages 11-84 through 11-103

TEMPCO Over-the-Side Chemical Bath Immersion Heaters are available in a variety of sheath materials and heater configurations to cover the widest possible spectrum of chemical heating applications. From plain steel to Teflon® covered, Tempco is sure to have the correct heater for even the most difficult application. Built-in thermal overload protection prevents premature heater burnout in low liquid level conditions. This thermal protection also guards against a potentially hazardous situation should the heater be in close proximity to combustibles such as a plastic tank, or the medium being heated.

Deep Tank/Sump Immersion Heaters

See Page 11-82

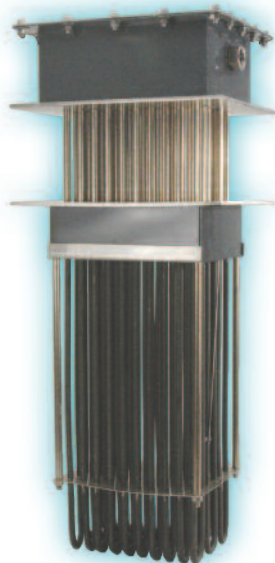

Process Tubular Forced Air Duct Heaters

See Pages 11-104 through 11-113

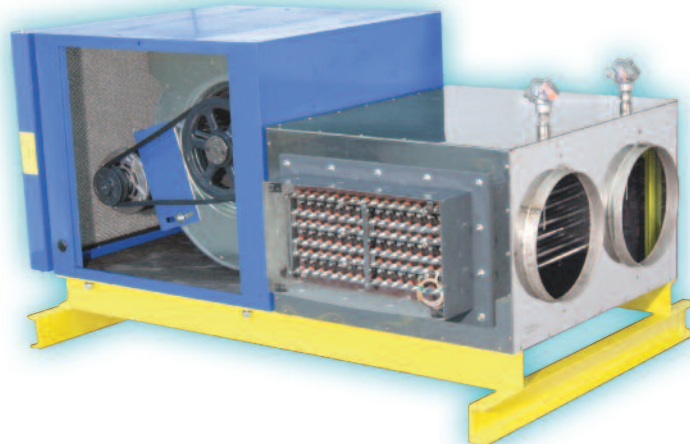

← FULL SYSTEM

Pictorial Index

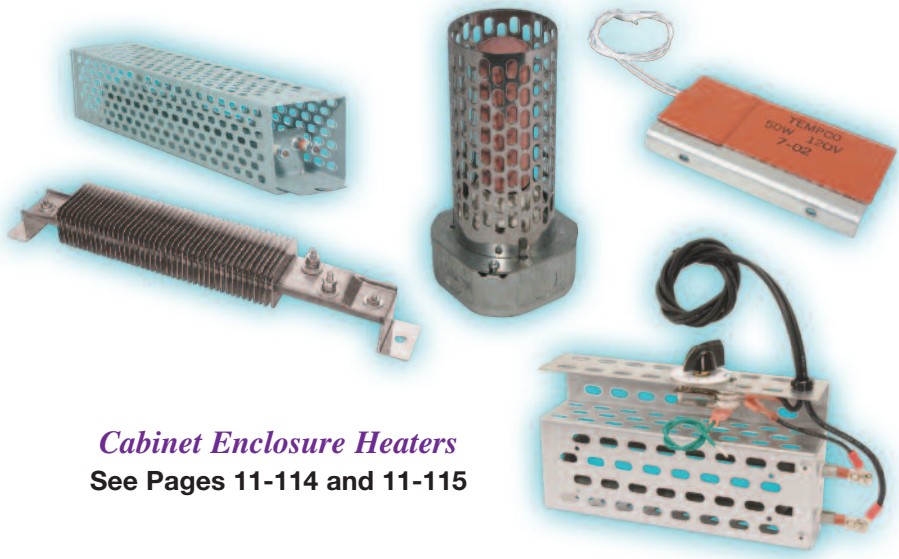

Cabinet Enclosure Heaters
See Pages 11-114 and 11-115



Heated Hose
See Pages 11-116 and 11-117

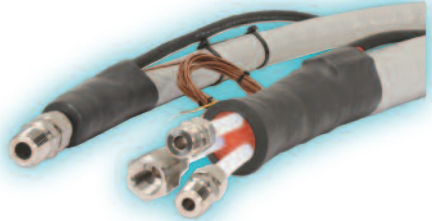

Heated Tubing
See Pages 11-118 and 11-119



Drum Heaters See Pages 11-120 through 11-123



Drum Blanket Heaters and Tote Tank Heaters See Pages 11-124 through 11-128

Instrumentation

Instruments used for temperature measurement and recording. Includes current indicators and multimeters.

Section 12

Catalog Pages
12-1
through
12-60



Videographic Data Logger and Paper Chart Recorders

See Pages 12-2 through 12-11

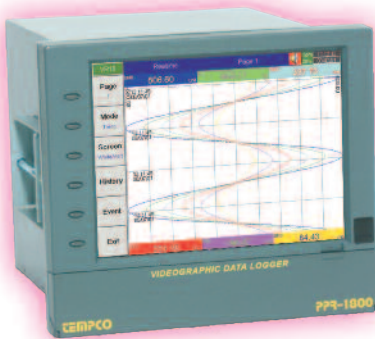

- * Videographic Data Logger
- * Up to 18 Channels



- * 180 mm Paper Format
- * Up to 30 Channels



- * 100 mm Paper Format
- * 6 Channel Dotting Recorder

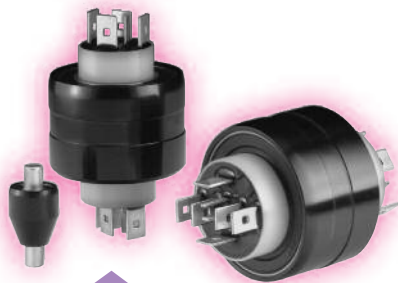

Rotating Multi-Pin Electrical Connectors

See Pages 12-12 through 12-17

- * Models with one through eight conductors
- * Amperage Ratings: 4, 30, 125 Amps

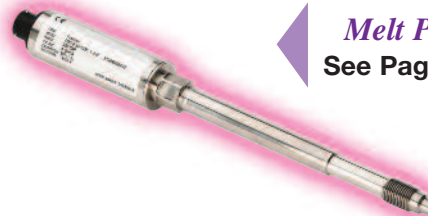

Melt Pressure Transducers

See Pages 12-18 through 12-23

Melt Pressure Gauges

See Pages 12-24 and 12-25



Melt Pressure Displays

See Pages 12-26 through 12-28



Rupture Discs

See Page 12-29



Portable Infrared Thermometers

See Pages 12-30 through 12-33

- * Laser Sighting on All Models
- * Optical Resolution from 12:1 up to 60:1

Pictorial Index

*Noncontact Infrared
Temperature Measurement
NCIT-LC Plus Series*

See Pages 12-34 and 12-35



DISCONTINUED

*Noncontact Infrared
Temperature Measurement
NCIT-LC Advanced Series*

See Pages 12-36 through 12-38

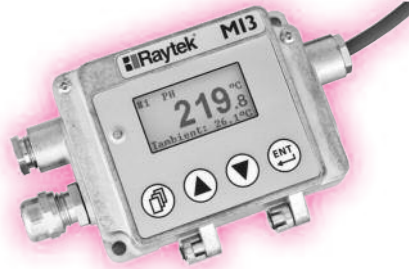

*Noncontact Infrared
Temperature Measurement
NCIT-LLC Series*

See Page 12-39



*Noncontact Infrared
Temperature Measurement
NCIT Plus Series*

See Page 12-40



Temperature Transmitters
See Pages 12-44 through 12-49

Temperature Monitors

See Pages 12-52 and 12-53



DISCONTINUED

Bimetal Dial Thermometers

See Pages 12-54 and 12-55



Temperature Displays

See Page 12-50



Current Indicators

See Page 12-56



* Separate Current Transformer and Panel Mount LEDs

Current Sensing Relays

See Page 12-57

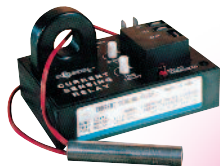

* Monitors Currents from 10mA to 100AC Amps
* Variable Trip Point

Electronic Test Instruments

See Pages 12-58 and 12-59



* Multimeter
* Megohmmeter
* Amp Clamp
* Digital Temperature Displays

Digital Thermometers

See Page 12-60



Temperature Control

Section 13

TEC Temperature Controllers and other components required to complete your thermal loop system.



Catalog Pages
13-1
through
13-96

1/32 DIN Digital Controls



- TEC-220** (\$160.00)
- * NEMA 4X Front
 - * 3 Programmable Outputs
- See Page 13-4



- TEC-2500** (\$225.00)
- * NEMA 4X Front
 - * 4 Programmable Outputs
 - * Heater Break Alarm
- See Page 13-6

1/16 DIN Digital Controls



- TEC-920** (\$155.00)
- * Low Cost
 - * Single Display
 - * 2 Programmable Outputs
- See Page 13-8



- TEC-9100** (\$170.00)
- * 4 Programmable Outputs
 - * Dual Display
 - * Cutting Edge Technology
- See Page 13-10



- TEC-9090** (\$180.00)
- * 2 Programmable Outputs
 - * Dual Display
- See Page 13-12



- TEC-9300** (\$215.00)
- * 4 Programmable Outputs
 - * Heater Break Alarm
 - * NEMA 4X Front
- See Page 13-14

FM High Limit Controls



- TEC-410** 1/4 DIN (\$285.00)
- * High Limit Control
 - * External Reset Optional
 - * Retransmission Optional
 - * Latching Relay
- See Page 13-16



- TEC-910** 1/16 DIN (\$180.00)
- * High Limit Control
 - * External Reset Optional
 - * Retransmission Optional
 - * Latching Relay
- See Page 13-16

Ramp & Soak Controls



- TEC-4500** 1/4 DIN
(\$330.00)



- TEC-9500** 1/16 DIN
(\$220.00)

- * 9 Recipes
 - * 16, 32 or 64 Segments per Recipe
- See Page 13-18

1/16 DIN Display Only



- TEC-900** (\$155.00)
- * Display Only
 - * T/C or RTD Inputs
 - * High or Low Voltage Operation
- See Page 13-20

1/16 DIN Analog Controls



TEC-905 (\$180.00)
 * Pushwheel Setpoint
 * Process Digital Display
 See Page 13-20



TEC-901 (\$105.00)
 * Non-Indicating
 * Potentiometer Setpoint
 See Page 13-22



TEC-902 (\$115.00)
 * With High /Low LEDs
 * Potentiometer Setpoint
 See Page 13-22

1/8 DIN Analog Control



TEC-805 (\$190.00)
 * Primary Output
 * Deviation Alarm Optional
 * Multiple Ranges Available
 * Process Digital Display
 * Pushwheel Setpoint
 See Page 13-28

3/16 DIN Digital Controls



TEC-7100 (\$210.00)
 * 4 Programmable Outputs
 * Compact Size
 See Page 13-30



TEC-704 (\$145.00)
 * Process Digital Display
 * Potentiometer Setpoint
 See Page 13-32

1/8 DIN Digital Controls



TEC-8100 (\$195.00)
 * 4 Programmable Outputs
 * NEMA 4X Front Optional
 * Cutting Edge Technology
 See Page 13-24



TEC-8300 (\$315.00)
 * 5 Programmable Outputs
 * Heater Break Alarm
 * Differential Control
 * Loop Break Alarm
 * Analog Input
 * Event Input
 * Retransmission Output
 See Page 13-26

1/4 DIN Digital Controls



TEC-4100 (\$235.00)
 * 4 Programmable Outputs
 * NEMA 4X Front Optional
 * Retransmission Output
 See Page 13-34



TEC-4300 (\$315.00)
 * 5 Programmable Outputs
 * Heater Break Alarm
 * Differential Control
 * Loop Break Alarm
 * Analog Input
 * Event Input
 * Retransmission Output
 See Page 13-36



1/4 DIN Analog Controls



TEC-404 (\$145.00)
 * Potentiometer Setpoint
 * Process Digital Display
 * Deviation Alarm Optional
 See Page 13-38



TEC-401 (\$105.00)
 * Non-Indicating
 * Potentiometer Setpoint
 * Low Cost
 See Page 13-40



TEC-405 (\$205.00)
 * Pushbutton Setpoint
 * Process Digital Display
 * Deviation Alarm Optional
 See Page 13-38



TEC-402 (\$115.00)
 * Process Deviation Meter
 * Potentiometer Setpoint
 * Low Cost
 See Page 13-40

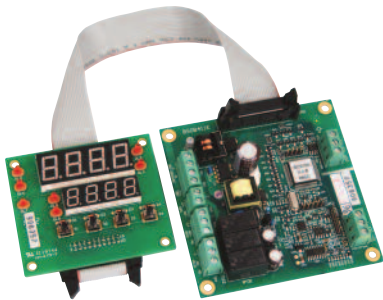

TBC-41 (\$140.00)
 * Board PID Temperature Control
 * 4 Programmable Outputs
 See Page 13-42

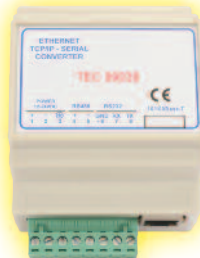
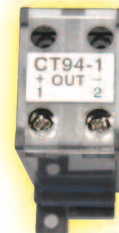
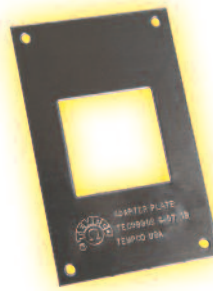

TEC Accessories

See Pages 13-47 through 13-49

- Rail Surface Mount Adapters
- Polycarbonate Terminal Covers
- Adapter Plates
- Current Transformer/Transducer
- Cable Communication Accessories



Series TKZ Encapsulated Temperature Controller
See Page 13-50

The encapsulated design allows for use in areas of high humidity and components are less likely to be damaged in handling.

Infinite Heat Switch
See Page 13-51

Designed to modulate power to the resistive load without feedback.

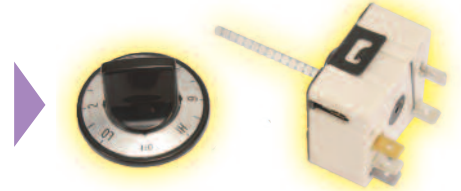

Temperature Control Panel Console Systems
See Pages 13-52 and 13-53

Tempco's consoles are offered in models from 1 to 4 zones, completely wired.

PCT Series Thermostat and Temperature Control
See Page 13-54



PCM-1000 Series Pre-Wired Power Control Boxes
See Page 13-55



CONTINUED →



Power Control Panels

See Pages 13-56 through 13-63

All Control Consoles and Power Control Panels are manufactured in our UL Certified Panel Shop.

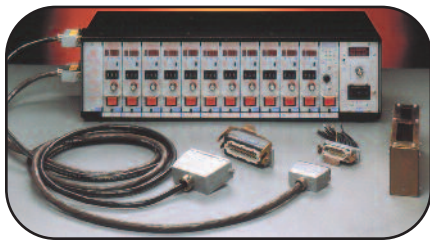

Hot Runner Injection Molding Temperature Control Systems

See Pages 13-64 through 13-66

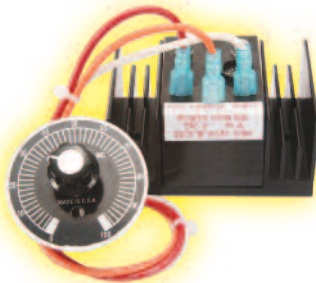

Solid State Variable Power Controllers

See Page 13-67

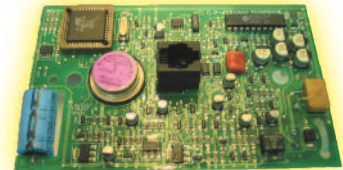

Contract Manufacturing

See Pages 13-68 and 13-69

Electronic control systems from Printed Circuit Board Assemblies to full assemblies including brackets, wiring and connectors

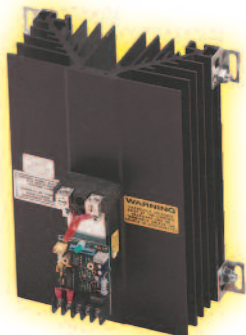

SCR Power Controllers

See Pages 13-70 through 13-75

- * Single phase 15 through 1200 Amp
- * Three phase 15 through 1200 Amp
- * Zero cross and phase angle firing





Bulb & Capillary Thermostats
See Pages 13-76 through 13-80

- * Single pole
- * Double pole
- * Double pole with high limit
- * Thermostat kits, enclosures and thermowells

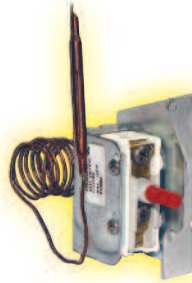

Bulb & Capillary High Limit Switch
See Page 13-80

- * Single pole
- * Manual reset button

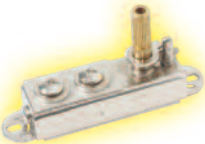

Surface Mount Thermostats
See Page 13-81

- * Adjustable and pre-set setpoints
- * Ranges from 50 to 570°F (10 to 300°C)



1/2" Disc Thermostats
See Pages 13-82 and 13-83

- * Pre-set snap action
- * High limit with manual reset
- * Setpoints from 50 to 500°F (10 to 260°C)

One Shot Thermal Cutoffs
See Page 13-84

- * Small size: 0.55" long x 0.16" diameter
- * Cutoff temperatures from 151 to 464°F (66 to 240°C)



Cartridge Type Thermostats
See Pages 13-85 through 13-87

- * Diameters include 1/4", 1/2" and 5/8"
- * Adjustable range from -100 to 600°F (-73 to 260°C)
- * Styles include: straight cartridge, block head, pipe thread, coupling head and flange

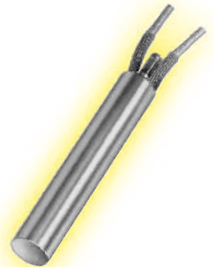

Single Phase Solid State Relays
See Pages 13-88 through 13-91

- * Single phase – Load current: 10 to 75 Amps
- * Three phase – Load current: 25 and 50 Amps
- * AC and DC control inputs

Solid State DIN Rail Relay Modules
See Pages 13-90 and 13-91

- * With built-in heat sink, AC and DC control inputs
- * Single phase models – Load current: 10 to 45 Amps
- * Three phase models – Load current: 25 Amps



Mercury Relays

See Pages 13-92 through 13-94

- * One to three poles
- * Load current: 30 to 100 Amps

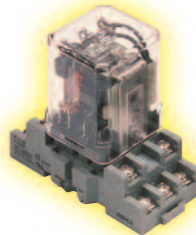
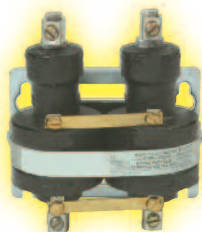

DIN Rail Mounted Mechanical Relays
See Page 13-95

- * One to three poles
- * Load current: 10 and 15 Amps



IEC Style Enclosed Contactors
See Page 13-96

- * Three pole
- * Auxiliary contacts
- * Load current: 25 to 100 Amps

Temperature Sensors

Section 14

Thermocouples, RTDs, Thermistors and related accessories



Catalog Pages
14-1
through
14-126

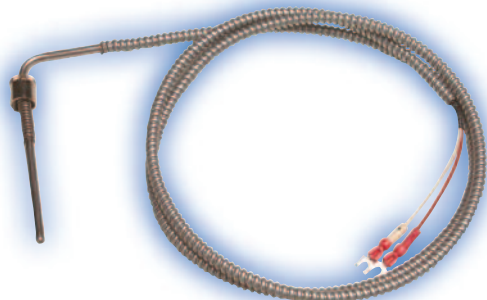

General Purpose Thermocouples

See Pages 14-2 through 14-11

Tempco has a wide variety of standard designs and a large stock of thermocouples specifically manufactured for the plastics and commercial industry as well as light to medium duty applications where more costly types of thermocouples are not necessary. All thermocouples are available in ANSI Type J (Standard), K, T and E calibrations.

Mineral Insulated Thermocouple Assemblies

See Pages 14-12 through 14-31

Tempco manufactures a wide variety of standard and custom designs for many diverse industries and applications in temperature ranges from cryogenic -200°C (-328°F) to 2315°C (4200°F). When you have a special requirement or a difficult application, consult Tempco.

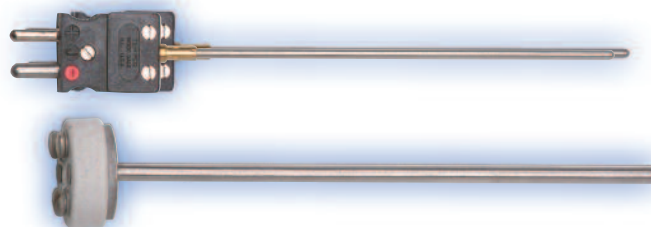

Multipoint Thermocouples

See Pages 14-28 through 14-31

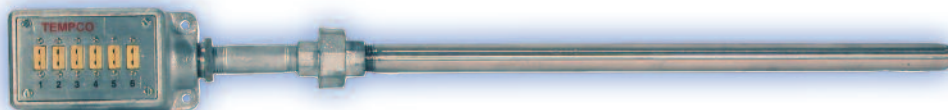

Industrial Process Thermocouples

See Pages 14-32 through 14-45

Tempco manufactures many styles of industrial thermocouple assemblies for a wide range of industries, from petrochemical to textile applications, where one or more protection tubes may be necessary to protect the thermocouple; available with Base Metal and Noble Metal thermocouples.

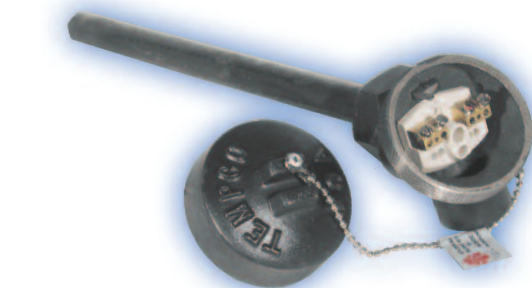

Accu-Ohm RTDs and Thermistors for Industrial, Plastics and Medium and Light Duty Applications
See Pages 14-46 through 14-66

Tempco's RTDs (*Resistance Temperature Detectors*) are designed to meet IEC Publication 751, DIN43760, JIS1604-1989 and BS1904-1984. They are normally supplied to Class B, but can be manufactured to Class A as an option. RTDs offer greater repeatability and interchangeability than thermocouples or thermistors over the standard temperature scale from -260°C to 630°C (-436 to 1166°F).

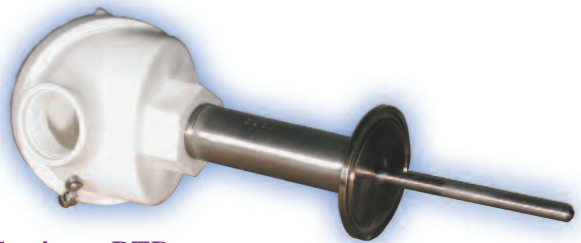
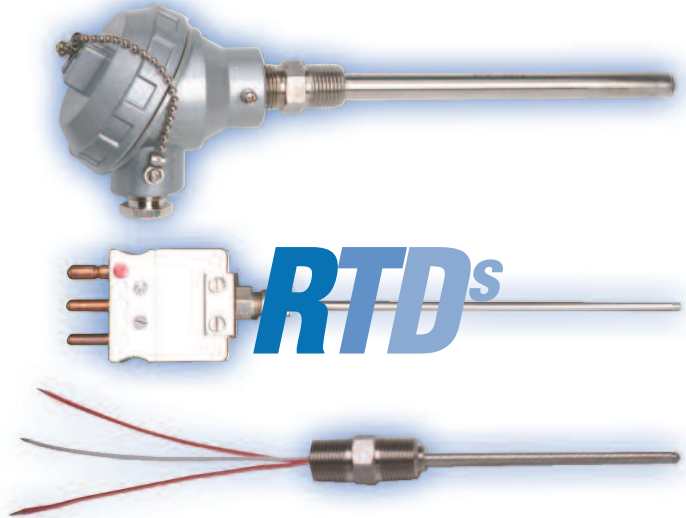

Sanitary RTDs
See Page 14-60

Special Application Thermocouples
See Pages 14-68

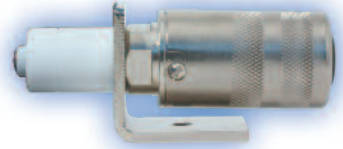

Jack Panels and Accessories
See Pages 14-69 through 14-75

Tempco's Jack Panels are made from rugged, .090" thick aluminum and allow for easy installation of multi-circuit thermocouple or RTD Quick Disconnect Jacks in your panel or housing.

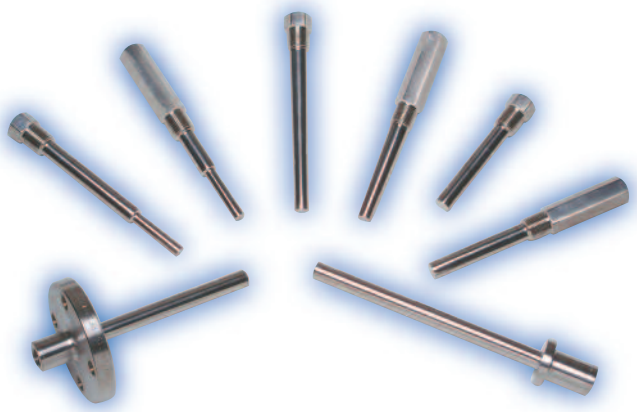

Thermowells, Ceramic and Metal Protection Tubes
See Pages 14-76 through 14-86

Tempco offers standard and custom manufactured Thermowells and Protection Tubes that give you an excellent variety of ways to protect your temperature sensor from high velocity, high pressure and corrosive and harsh environments.

CONTINUED →

Hardware and Accessories

See Pages 14-87 through 14-101

- Bayonet Type Adapters
- Compression Fittings
- Protection Tube Mounting Parts
- Plugs and Jacks
- Terminal Blocks
- Thermocouple Heads
- Thermocouple Terminal
- Plastic Melt Bolts

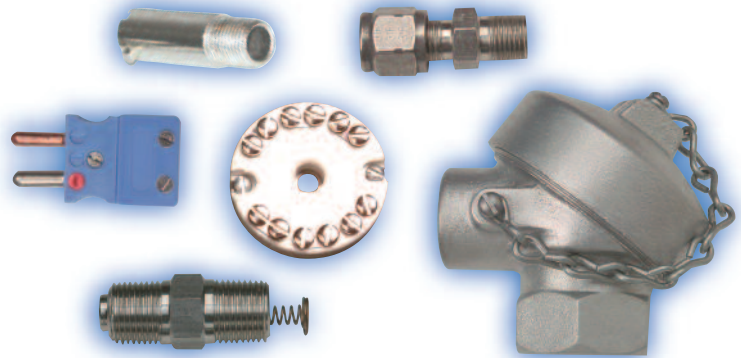

Plastic Melt Bolts

See Page 14-101



Spooled Thermocouple and Thermocouple Extension Wire

See Pages 14-107 through 14-110

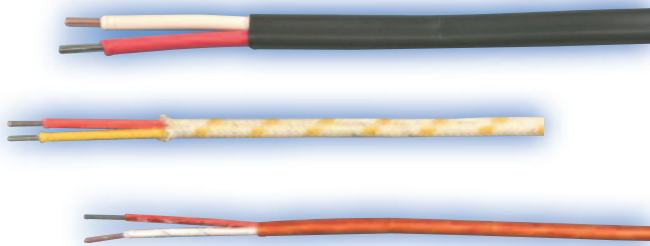

Insulated Thermocouple and Extension Wire

See Pages 14-102 through 14-113

This section presents the most commonly used insulated thermocouple and thermocouple extension wire available from stock in all the ANSI recognized calibrations. All thermocouple and thermocouple extension wires are supplied to meet Standard Tolerances of ANSI Circular MC96.1-1982. Special tolerances to ANSI MC96.1 are available at an extra charge.

Metal Sheathed Mineral Insulated Thermocouple Cable (MI T/C Cable)

See Pages 14-114 through 14-124

Tempco offers a wide variety of sheathed, mineral insulated thermocouple cable. We stock many varieties of sheath diameters and materials in ANSI recognized thermocouple types and can manufacture a multitude of non-stock combinations of sheath materials, O.D.s, insulations, wire types and wire configurations on special request; consult Tempco with your specific requirements.

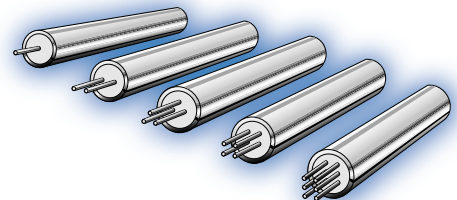

Glossary of Temperature Sensing Terms

See Pages 14-125 and 14-126

Accessories

Section 15

High temperature lead wire, ceramic terminal blocks and wire nuts, sleeving, electrical plugs and other items



Catalog Pages
15-1
through
15-18



Spooled High Temperature Lead Wire

See Page 15-2

- Type MG — 600 Volt, 550°C (1022°F), UL 5400
- Type MG — 600 Volt, 450°C (842°F), UL 5335/5107
- Type TGGT — 600 Volt, 250°C (482°F), UL 5256



Spooled PTFE Lead Wire

See Page 15-3

- Type PTFE — 300 Volt, 200°C (392°F), UL 1180



Spooled Type J and K Duplex Thermocouple Wire

See Page 15-4



Spooled Type JX and KX Thermocouple Extension Wire

See Page 15-4

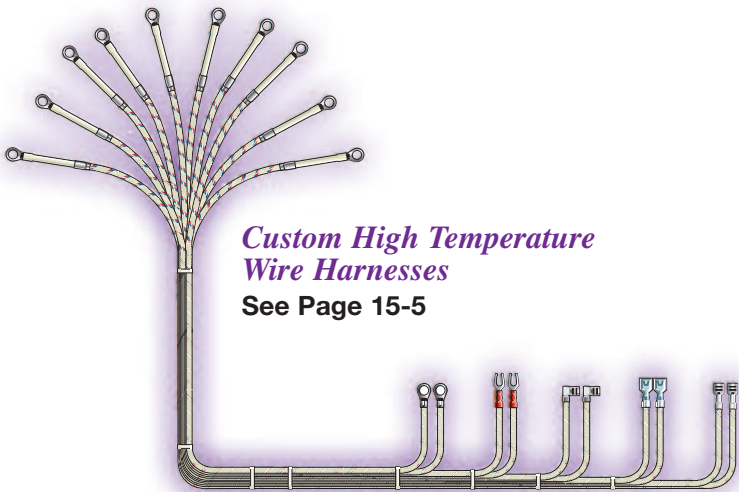

Custom High Temperature Wire Harnesses

See Page 15-5

Resistance Wire & Ribbon

See Pages 15-6 through 15-9



CONTINUED →



Ceramic Terminal Blocks and Wire Nuts

See Pages 15-10 through 15-12

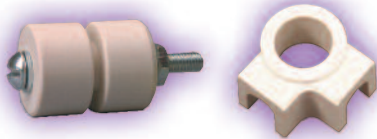

Stock Ceramic Accessory Items

See Page 15-13

Lead Wire Protection

See Page 15-14



High Temperature Plugs

See Page 15-14

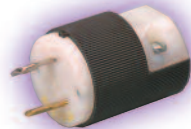

Heavy Duty Plugs

See Page 15-15



Terminal Boxes

See Page 15-15

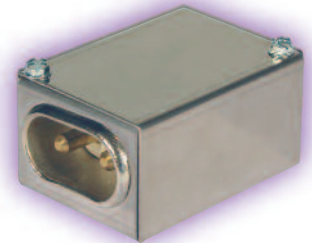

Insulation Blankets

See Pages 15-16 and 15-17



High Temperature Terminal Lugs

See Page 15-18

Irreversible Temperature Strip and Indicators

See Page 15-18

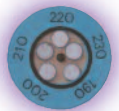

Engineering

Find formulas for calculating required wattage, sheath selection material tables and other useful data. Need additional help? Please contact our rock-solid engineering team at 800-323-6859.



Section 16

Catalog Pages

16-1
through
16-23



Table Of Contents

Pictorial Index	A-4
Mi-Plus® (Mineral Insulated Band)	1-2
Duraband® (Mica Band)	1-24
Injection Molding Replacement Band Heaters	1-52
Ceramic Band	1-60
Tubular Barrel and Nozzle Band.....	1-78
MaxiBand®	1-80

1

section

Band Heaters

Mi-Plus[®] Mineral Insulated Band Heater

**A High Performance Band Heater With Outstanding Design Features
(Temperature Capabilities To 1400°F/760°C)**

1400°!
*?@#%!+\$
Later, I'm
Callin' Our
Travel
Agent!

You've Got
to Love
Those Igloo™
Terminal
Covers.
His & Her
Entrances!

Check Out
These
Smooth
Inside
Seams.
Hmmm...
Tight
Seals!

I've Heard
Not Even a
Chicago Bear
Can Break the
Screw
Terminals.

Bear?...
Who Said
Bear?
I'm Outta
Here!!!

Hey You Guys, Feast
Your Eyes on the
Selection and
Construction Styles.

WOW!
and
The Cool
Blue is
Totally
In!

Tough
One-
Piece
Integral
Clamping
Bracket.

One-Piece,
Two-Piece
and One-
Piece
Expandable
Construction.
Speaking of
Expandable...
Nice Swim-
suit.

From
Stock?

Yep, and
Made to
Order
Too!

Characters as depicted are
trademarks of Tempco
Electric Heater Corporation.
© All Rights Reserved

Mi-Plus® Construction Characteristics

The *Mi-Plus* is the solution for applications that require high watt densities (W/in^2) and/or high operating temperatures.

Mi-Plus band heaters are capable of temperatures up to 1400°F (760°C) and watt densities up to 150W/in² (23.25W/cm²). The recommended maximum watt density for a specific application will depend on the heater size and its operating temperature.

Specially formulated mineral insulated tape providing excellent thermal conductivity and dielectric strength is used to insulate the nickel chrome resistance wire from the stainless steel sheath. The heater assembly is formed under pressure to a precise diameter with a thin low-mass cross section, assuring fast heat-up rates and reduced cycle times.

UNBREAKABLE Power Screw Terminals

Only Mi-Plus offers this unique screw terminal design...

The stainless steel power screw terminals are resistant to over-torquing. *For complete selection of screw terminal arrangements, see pages 1-14 and 1-15.*



SUPERIOR Clamping Mechanism

The clamping brackets are formed from the outer sheath of the heater, providing a unique one-piece built-in construction strap. The clamping power is generated through barrel nuts and socket head screws, which as an

integral part of the built-in strap, provide superior clamping force for maximum performance and optimal heater life. *For details, see pages 1-12 and 1-13.*

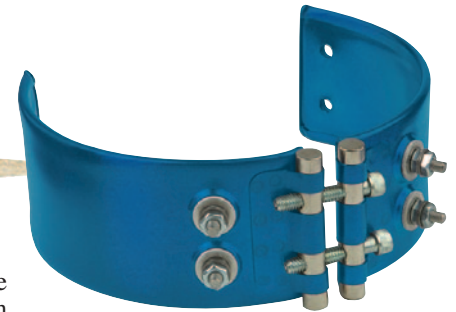

INNOVATIVE Lead Terminations

Smaller size *Mi-Plus* band heaters are powered-up by means of lead wire terminations. To insure a resilient connection that will withstand abrasion, mechanical abuse and keep contaminants out of the transition area, a specially designed stainless

steel transition cap with a built-in strain relief was developed. The cap is welded to the sheath and the cavity is filled with insulating cement, sealing the band heater from contaminants. *For details, see pages 1-16 through 1-19.*

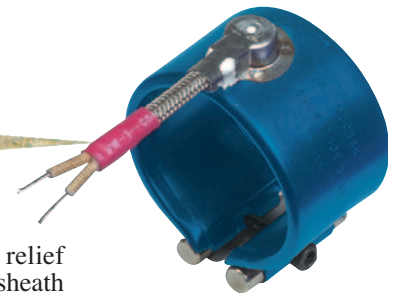

UNIQUE Igloo™ Ceramic Covers

To eliminate exposed wiring/screw terminals on band heater installations, single and double port ceramic caps were designed. These unique and exclusive Igloo ceramic terminal

insulators fit over the entire terminal and lug, leaving no exposed wiring. *For additional details on Igloo insulators, see page 1-15.*





Mi-Plus Specifications

Mi-Plus® Standard Specifications and Tolerances

PERFORMANCE RATINGS

Maximum Temperature: 1400°F (760°C)

Nominal Watt Density:

Nozzle Bands — under 3" diameter:
30-100 W/in² (4.7-15.5 W/cm²)

Barrel bands—3" and greater in diameter:
20-70 W/in² (3.1-10.9 W/cm²)

Maximum Watt Density: 150 W/in² (23 W/cm²) Dependent on heater size, operating temperature and termination.

ELECTRICAL RATINGS

Maximum Voltage: 480VAC per termination

Dual Voltage: Available depending on heater configuration

Maximum Amperage: lead wire termination: 10A
screw terminations: 8-32UNF—20A
10-32UNF—25A

Resistance Tolerance: +10%, -5%

Wattage Tolerance: +5%, -10%



Exposed electrical wiring on band heater installations is a violation of Electrical Safety Codes including O.S.H.A.

PHYSICAL SIZE CONSTRUCTION LIMITATIONS

Nominal Gap—Built-In Bracket:

less than 1-3/4" dia. 1/4"
1-3/4" to 2" dia. 5/16"
2" to 5" dia. 3/8"
5" to 18" dia. 1/2"
greater than 18" dia. . . . 3/4"

If a larger gap is required for probes or thermocouples, specify when ordering.

Maximum Inside Diameters:

One-Piece *14" (355.6 mm)
One-Piece Expandable .. *14" (355.6 mm)
Two-Piece 25" (635.0 mm)
Over 25" (635.0 mm) will require multiple segments. Consult Tempco.

* Tempco recommends two-piece construction for heaters 10" ID and greater

Standard Widths: 1" to 8" (25.4 mm to 203.2 mm)

Width Tolerance: ±3/32" (2.4 mm)

If non-standard widths or tighter tolerances are required, consult Tempco.

Diameter/Width Limitations

Width		One-Piece Construction Inside Diameter		Expandable Construction Inside Diameter		Two-Piece Construction Inside Diameter	
in	mm	in	mm	in	mm	in	mm
1	25.4	1 to 10	25.4 to 254.0	N/A	N/A	3 to 25	76.2 to 635.0
1½	38.1	1 to 14	25.4 to 355.6	2½ to 14	63.5 to 355.6	3 to 25	76.2 to 635.0
2	50.8	1½ to 14	38.1 to 355.6	2½ to 14	63.5 to 355.6	3 to 25	76.2 to 635.0
2½	63.5	1½ to 14	38.1 to 355.6	2½ to 14	63.5 to 355.6	3 to 25	76.2 to 635.0
3	76.2	1½ to 14	38.1 to 355.6	2½ to 14	63.5 to 355.6	3 to 25	76.2 to 635.0
3½	88.9	1¾ to 14	44.5 to 355.6	2½ to 14	63.5 to 355.6	3 to 25	76.2 to 635.0
4	101.6	2 to 14	50.8 to 355.6	2½ to 14	63.5 to 355.6	3 to 25	76.2 to 635.0
4½	114.3	2¼ to 14	57.2 to 355.6	2½ to 14	63.5 to 355.6	3 to 25	76.2 to 635.0
5	127.0	2½ to 14	63.5 to 355.6	2½ to 14	63.5 to 355.6	3 to 25	76.2 to 635.0
5½	139.7	2¾ to 14	69.9 to 355.6	3 to 14	63.5 to 355.6	3 to 25	76.2 to 635.0
6	152.4	3 to 14	76.2 to 355.6	3 to 14	76.2 to 355.6	3 to 25	76.2 to 635.0
6½	165.1	3¼ to 14	82.6 to 355.6	3¼ to 14	82.6 to 355.6	3¼ to 25	82.6 to 635.0
7	177.8	3½ to 14	88.9 to 355.6	3½ to 14	88.9 to 355.6	3½ to 25	88.9 to 635.0
7½	190.5	3¾ to 14	95.3 to 355.6	3¾ to 14	95.3 to 355.6	3¾ to 25	95.3 to 635.0
8	203.2	4 to 14	101.6 to 355.6	4 to 14	101.6 to 355.6	4 to 25	101.6 to 635.0

Additional Limitations

- For heaters less than 4" in diameter, the maximum width is twice the diameter.
- Heaters with standard brackets are available from 1" to 8" wide, while heaters with low profile brackets are available from 1" to 6" wide.
- 1" diameter heaters are only available in 1" and 1-1/2" widths.
- For heaters from 10" diameter up to 25" diameter, Tempco recommends using 2-piece construction for superior clamping. Over 25" diameter, 3 or 4 segments are recommended.
- Combinations of some minimum and maximum variations may not be available. Consult Tempco with your special requirements.
- Post terminals are only available on heaters greater than 2-1/2" in diameter and 1-1/2" in width.

Mi-Plus® Maximum Watt Densities

MAXIMUM ALLOWABLE WATT DENSITY

The chart displays the maximum Watt Density curves for various diameter heaters. Use this chart when determining the appropriate wattage value for your chosen heater.

Be aware that certain factors will require you to derate the watt density (W/in²) of your heater selection.

CAUTION Failure to adhere to the maximum allowable watt density per heater size will result in poor operating life.

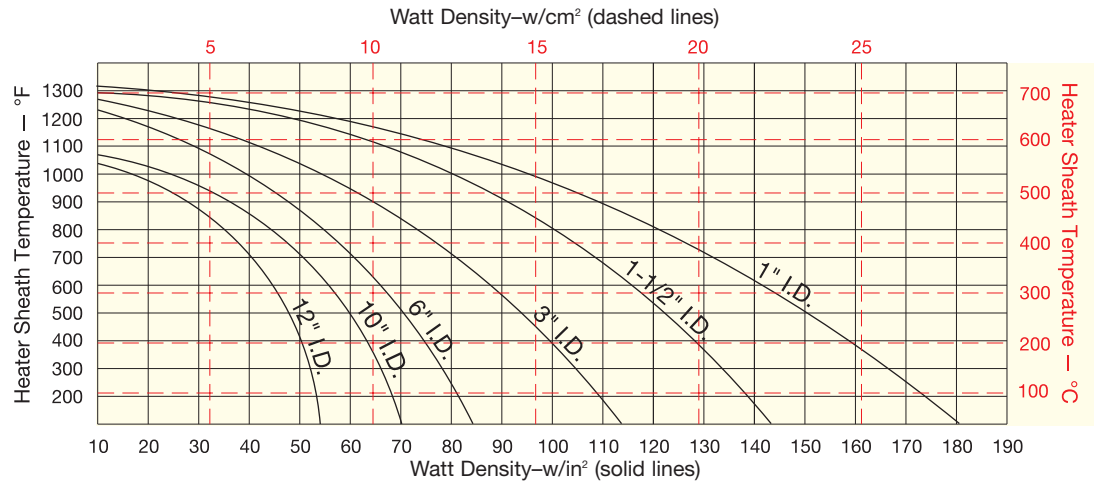

CALCULATING MAXIMUM WATT DENSITY

Factors to be taken into consideration:

- Type of controls
- Voltage variations
- Machine cycling rate
- Type of resin being processed
- Coefficient of thermal expansion and conductivity of the cylinder.
- Designing a heater that closely matches the wattage requirement will decrease the frequency of cycling and temperature overshoot, thereby increasing the life of the heater.

Once these factors have been established, proceed with the following steps:

- Determine the maximum operating temperature.
- Calculate the total wattage required to obtain the maximum operating temperature.
- Determine the quantity and size of the heater bands to be used. Due to clamping concerns, 2" through 3" wide band heaters have long proven to be the most efficient and reliable in most cylindrical heating applications.
- Determine individual band heater wattage by dividing the total required wattage by the quantity of band heaters selected.

- Determine the band heater's heated area by subtracting unheated (cold) areas created by screw terminals, gaps, holes, and cutouts.

Nominal Unheated Areas	
Construction Style	Cold Area to Subtract
One-piece band	1" × width
One-piece expandable band	1½" × width
Two-piece band	2" × width

For each hole or cutout add to the cold area from the Table the (Hole size + ½") × heater width. This is total cold area to use in the following formula to calculate the heater watt density.

Watt Density Formula

$$\text{Watt Density (W/in}^2\text{)} = \frac{\text{Wattage}}{(3.14 \times \text{Band ID} \times \text{Band Width}) - (\text{Cold Area})}$$

- Check in the above graph that the calculated watt density does not exceed the maximum recommended watt density. Locate the maximum cylindrical temperature required on the left-hand side of the graph, follow the horizontal line until it intersects with the line of the band heater being used, and read directly down to obtain the maximum recommended watt density (watts/in²).
- If the calculated watt density is higher than the recommended value, it must be corrected or it will cause poor heater life. This can be accomplished by using more band heaters or lowering the heater wattage.
- Should you have a problem in selecting the proper band heater or establishing watt density for your application, consult Tempco.

CORRECTION FACTORS

For heaters wider than 3" (76.2 mm), reduce maximum allowable watt density from chart by 20%.

For applications using insulating shroud, reduce maximum allowable watt density from chart by 25%.

CAUTION Do not use insulating blankets if heater temperatures are above 1200°F (649°C). Failure to adhere will result in premature heater failure.

Mi-Plus[®] Terminator Program

Mi-Plus Nozzle Band Heaters
Available From Stock
Within 48 Hours

6
Terminations
To Choose From

Type W1

Straight wire
braid leads;
for complete details
refer to page 1-16

Type W2

Right-angle wire
braid leads, parallel
to heater; for
complete details
refer to page 1-16

Type W5

Right-angle wire
braid leads, 90
degrees to heater;
for complete details
refer to page 1-17

Type L1

Plain wire leads; for
complete details
refer to page 1-19

Type R1

Straight armor cable;
for complete details
refer to page 1-17

Type R2

Right-angle armor cable;
for complete details refer
to page 1-18

Mi-Plus[®] Band Heater Terminator Program

These Mi-Plus Band Heaters are in-stock, semi-finished (substrates), offering the option to finish them by choosing from the 6 program-qualified lead end terminations listed above.

Mi-Plus Terminator Band Heaters will be ready for shipment within 48 hours.

Stock Mi-Plus® Nozzle Band Heaters Available Through the Terminator Program

Part Numbers listed are for Heaters with Type W2 Termination – Right-Angle Wire Braid Leads (12" leads, 10" SS braid). Other Terminator Program terminations and options can also be applied to stock heaters (see Ordering Information below).

ID	Width		Wattage	Watt Density		Clamping/ Construction	Part Number		
	in	mm		W/in ²	W/cm ²		120V	240V	
1	25.4	1	25.4	150	70	10.9	WB	MPP50101	—
1	25.4	1	25.4	225	105	16.3	WB	—	MPP50206
1	25.4	1-1/2	38.1	200	62	9.7	WB	MPP50301	MPP50401
1	25.4	1-1/2	38.1	250	78	12.1	WB	—	MPP50601
1	25.4	1-1/2	38.1	300	93	14.5	WB	MPP50701	MPP50801
1-1/4	31.8	1	25.4	250	85	13.2	WB	MPP51101	MPP51202
1-1/4	31.8	1	25.4	275	94	14.6	WB	—	MPP51401
1-1/4	31.8	1-1/2	38.1	350	80	12.4	LB	MPP51701	—
1-1/4	31.8	1-1/2	38.1	350	80	12.4	WB	—	MPP51801
1-1/2	38.1	1	25.4	200	54	8.4	OB	MPP51901	MPP52001
1-1/2	38.1	1	25.4	225	61	9.5	OB	MPP02836	MPP02837
1-1/2	38.1	1	25.4	300	81	12.5	OB	MPP52301	MPP52402
1-1/2	38.1	1-1/2	38.1	300	54	8.4	LB	MPP52501	MPP52602
1-1/2	38.1	1-1/2	38.1	350	63	9.8	LB	MPP02352	MPP02353
1-1/2	38.1	1-1/2	38.1	450	81	12.5	LB	—	MPP52903
1-1/2	38.1	2	50.8	300	40	6.3	LB	—	MPP53001
1-1/2	38.1	2	50.8	400	55	8.5	LB	MPP02838	MPP00494
1-1/2	38.1	2	50.8	450	61	9.4	LB	—	MPP53202
1-1/2	38.1	3	76.2	350	31	4.9	LB	—	MPP53401
1-1/2	38.1	3	76.2	500	45	7.0	LB	—	MPP53501
1-3/4	44.5	1-1/2	38.1	300	44	6.9	LB	MPP53801	MPP53901
1-3/4	44.5	2	50.8	750	83	12.9	LB	—	MPP54301
1-3/4	44.5	2-1/2	63.5	550	49	7.6	LB	—	MPP54401
1-3/4	44.5	3	76.2	1000	74	11.5	LB	—	MPP54601
2	50.8	1	25.4	350	66	10.3	OB	MPP54701	MPP54801
2	50.8	1-1/2	38.1	400	50	7.8	LB	—	MPP54901
2	50.8	1-1/2	38.1	425	54	8.4	LB	MPP02839	MPP02840
2	50.8	2	50.8	750	71	11	LB	MPP55051	MPP55101
2-1/4	57.2	1	25.4	350	58	8.9	OB	—	MPP55401
2-1/4	57.2	2-1/2	63.5	1000	66	10.2	LB	—	MPP55801
2-1/2	63.5	1	25.4	400	58	9.0	OB	—	MPP56001
2-1/2	63.5	1-1/2	38.1	500	49	7.5	LB	—	MPP56101
2-1/2	63.5	1-1/2	38.1	525	51	7.9	LB	MPP02841	MPP00227

Ordering Information

Order by Part Number for stock Mi-Plus heaters with Type W2 termination. Call Tempco for part numbers for stock heaters with other Terminator Program (see page 1-6) terminations and options.

Custom Engineered/Manufactured

Mi-Plus Heaters can be application specific; therefore for sizes, electrical ratings, terminations and any other design features not listed in this catalog **TEMPCO** will custom manufacture to your specifications. Consult us with your requirements.



Standard Sizes and Ratings

Stock and Standard (Non-Stock) Mi-Plus Barrel Band Heaters

Part Numbers listed are for Heaters with Screw Terminal Terminations – Type T2 or T3X.

Part numbers for heaters with other terminations will be assigned at time of order.

Stock Items Are Shown In **RED**

ID		Width		Wattage	Voltage	Watt Density		Style	Clamping/ Construction	Terminal	Part Number
in	mm	in	mm			W/in ²	W/cm ²				
3	76.2	1-1/2	38.1	500	240	41	6.3	1 pc	NB	T2	MPP00230
3	76.2	1-1/2	38.1	525	240	43	6.6	1 pc	NB	T2	MPP00231
3-1/4	82.6	2-1/2	63.5	1100	120	48	7.4	1 pc	NB	T3X	MPP00232
3-1/4	82.6	2-1/2	63.5	1400	240	61	9.4	1 pc	NB	T3X	MPP00233
3-1/2	88.9	2	50.8	800	240	40	6.2	1 pc	NB	T3X	MPP00234
3-5/8	92.1	1-1/2	38.1	650	240/480	52	8	Exp	NE	T2	MPP00235
4	101.6	1-1/2	38.1	625	240/480	44	6.8	Exp	NE	T2	MPP00236
4	101.6	1-1/2	38.1	725	240/480	51	7.8	Exp	NE	T2	MPP00237
4	101.6	1-1/2	38.1	800	240	47	7.3	1 pc	NB	T2	MPP00238
4-1/2	114.3	2-1/2	63.5	1250	240	38	5.9	1 pc	NB	T3X	MPP00186
5	127	1-1/2	38.1	1000	240/480	52	8.1	Exp	NE	T2	MPP00239
5-1/4	133.4	1-1/2	38.1	600	240/480	30	4.6	Exp	NE	T2	MPP00240
5-1/4	133.4	1-1/2	38.1	1000	240/480	49	7.7	Exp	NE	T2	MPP00241
5-1/4	133.4	3	76.2	1700	240/480	39	6.1	Exp	NE	T3X	MPP00187
5-1/4	133.4	4-1/2	114.3	2400	240/480	37	5.7	Exp	NE	T3X	MPP00242
5-1/4	133.4	4-1/2	114.3	2700	240/480	41	6.4	Exp	NE	T3X	MPP00243
5-1/2	139.7	1-1/2	38.1	1000	240/480	47	7.2	Exp	NE	T2	MPP00244
5-1/2	139.7	1-1/2	38.1	1300	240/480	61	9.4	Exp	NE	T2	MPP00245
6	152.4	1-1/2	38.1	1000	240/480	42	6.5	Exp	NE	T2	MPP00246
6	152.4	1-1/2	38.1	1400	240/480	59	9.1	Exp	NE	T2	MPP00247
6-1/2	165.1	1-1/2	38.1	1250	240/480	48	7.4	Exp	NE	T2	MPP00248
6-3/4	171.5	1-1/2	38.1	815	240/480	30	4.6	Exp	NE	T2	MPP00249
6-3/4	171.5	1-1/2	38.1	1000	240/480	37	5.7	Exp	NE	T2	MPP00250
6-3/4	171.5	4	101.6	2600	240/480	34	5.2	Exp	NE	T3X	MPP00188
6-3/4	171.5	5	127	3700	240/480	39	6	Exp	NE	T3X	MPP00251
6-3/4	171.5	6	152.4	3750	240/480	33	5	Exp	NE	T3X	MPP00189
7	177.8	1-1/2	38.1	1250	240/480	44	6.8	Exp	NE	T2	MPP00252
7	177.8	1-1/2	38.1	1500	240/480	53	8.2	Exp	NE	T2	MPP00253
7-1/2	190.5	1-1/2	38.1	1500	240/480	49	7.5	Exp	NE	T2	MPP00254
7-5/8	193.7	3	76.2	1800	240/480	27	4.2	Exp	NE	T3X	MPP00255
7-5/8	193.7	4-1/2	114.3	3150	240/480	32	4.9	Exp	NE	T3X	MPP00190
8	203.2	1-1/2	38.1	1250	240/480	38	5.8	Exp	NE	T2	MPP00256
8	203.2	1-1/2	38.1	1600	240/480	48	7.5	Exp	NE	T2	MPP00257
9	228.6	1-1/2	38.1	1500	240/480	40	6.1	Exp	NE	T2	MPP00258
9	228.6	1-1/2	38.1	1750	240/480	46	7.2	Exp	NE	T2	MPP00259
9-1/2	241.3	3	76.2	3000	240/480	36	5.6	Exp	NE	T3X	MPP00191
11-1/4	285.8	3	76.2	2400	240/480	24	3.7	Exp	NE	T3X	MPP00260
11-1/4	285.8	5	127	5100	240/480	31	4.7	Exp	NE	T3X	MPP00261

Stock Mi-Plus Barrel Band Heaters are ready for immediate shipment with Screw Terminals.

Complete termination details are on pages 1-14 and 1-15.

Ordering Information

Stock Heaters

Select a Mi-Plus Barrel Band Heater from the list above.

Stock heaters can be modified to the following terminations:

- Type C—Outlet terminal box.
- Type P2—Low profile high temperature quick disconnect.
- Type C6, C7 and C8—Igloo™ ceramic terminal covers.

Custom Engineered/Manufactured Heaters

An electric heater can be very application specific; for sizes not listed **TEMPCO** will design and manufacture a Mi-Plus Barrel Heater to meet your requirements. **Standard lead time is 5 weeks.**

Please Specify the following:

- Inside Diameter
- Width
- Wattage
- Voltage
- Quantity
- Termination (see pages 1-14 through 1-21)
- Lead Cable/Braid Length
- Construction Style (see pages 1-10 and 1-11)
- Clamping Variation (see pages 1-12 and 1-13)
- Features/Options (see page 1-22)

WARNING: Cancer and Reproductive Harm - www.P65Warnings.ca.gov.

Special and Unique Mi-Plus® Band Heater Designs

Throughout our catalog we show Tempco's standard specifications and most popular designs. However, as a custom heating element manufacturer, we recognize that many applications require non-standard and unique designs.

At Tempco, we are constantly challenged by our customers to solve their heating applications. We have the experience, technical knowledge and manufacturing capability to solve all your heating problems with unique heater designs. Use Tempco's talent and capabilities to your benefit to solve your specific heating problem in an expeditious and cost-effective manner.

The following pictures show some of the heater designs that we have developed for special applications. Next time, when you have a special application and you want someone to work with you and "think outside the box" to solve your specific heating application, call Tempco.

We haven't seen all heating applications, but most likely our experienced staff has seen and solved more heating problems than you have seen.

*Put our knowledge and experience to work for you.
Challenge us! You will be glad you did.*

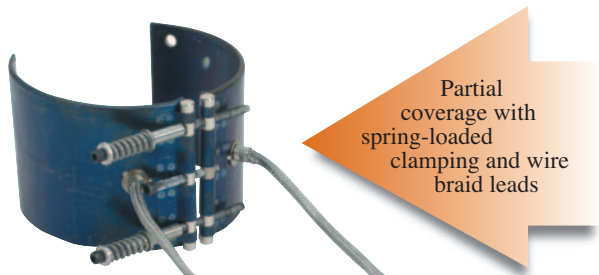

Partial coverage with spring-loaded clamping and wire braid leads

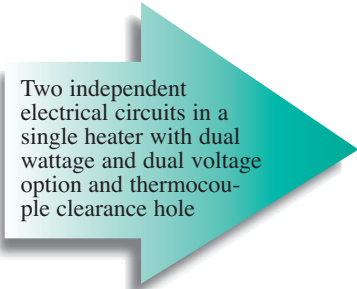

Two independent electrical circuits in a single heater with dual wattage and dual voltage option and thermocouple clearance hole

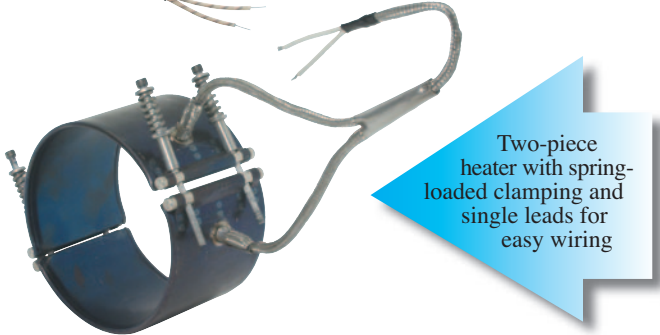

Two-piece heater with spring-loaded clamping and single leads for easy wiring

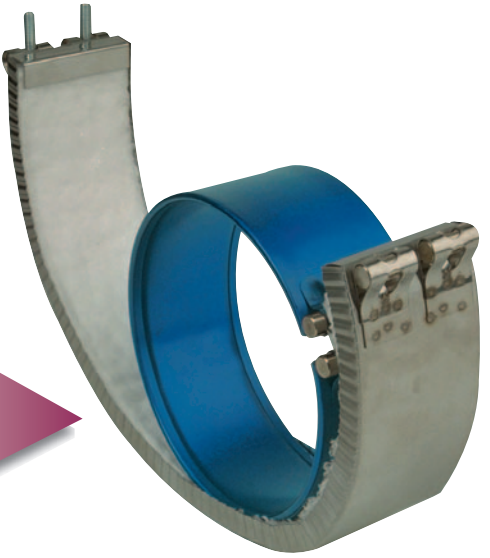

Heater with insulating shroud to minimize energy losses

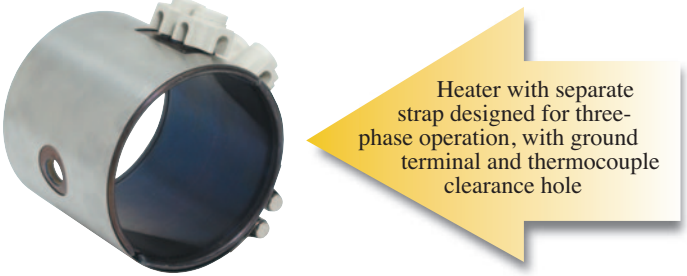

Heater with separate strap designed for three-phase operation, with ground terminal and thermocouple clearance hole

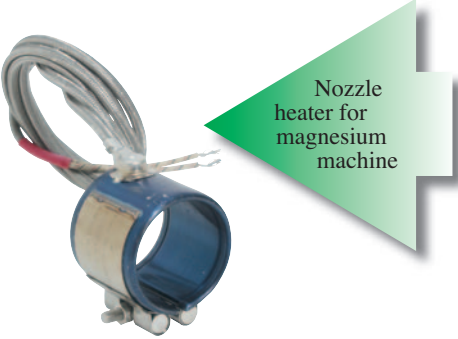

Nozzle heater for magnesium machine

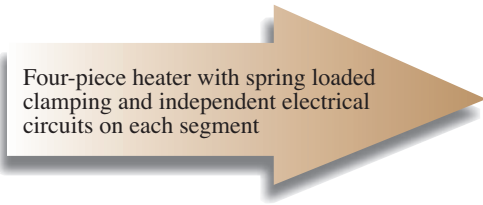

Four-piece heater with spring loaded clamping and independent electrical circuits on each segment

Mi-Plus® Construction Styles



Do not open Non-Expandable One-Piece Mi-Plus Band Heaters during installation. Opening this construction style will cause internal damage.



Shown with Type NB Built-In Strap

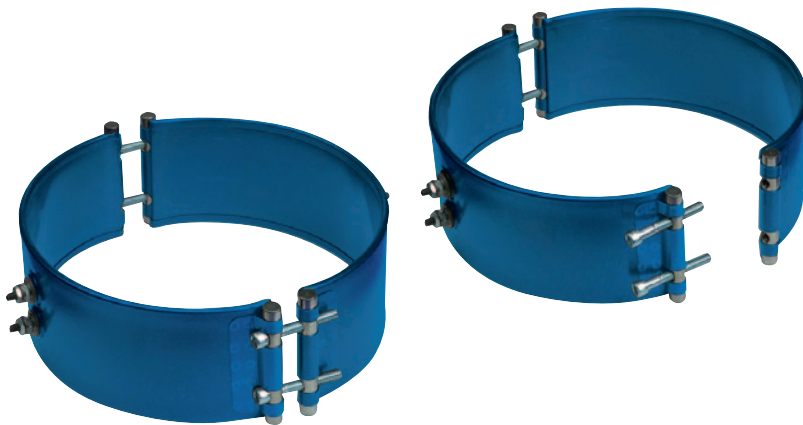

Shown with Type NS Built-In Strap



It is not recommended to open a One-Piece Expandable Band Heater more than two times.

Shown with Type NE Built-In Strap

Mi-PLUS BAND HEATERS...



Note: Refer to page 1-4 for complete Limitations on Physical Size Construction.

Non-Expandable One-Piece Band Construction

One-piece heaters are the most efficient construction, as they provide the most heated surface area. This style can only be used where the entire heater can be slipped over the end of the barrel. One-piece heaters have built-in, full-width clamping bars.

Two-Piece Band Construction

Two-piece construction satisfies the need for a heater that can be placed anywhere along the machine barrel with a minimum of time and labor. Two-piece construction is recommended for larger diameter heaters because two-piece construction employs two sets of built-in clamps that deliver maximum clamping force.

The two-piece construction style also provides dual voltage capability. The heater halves may be wired together either in series or parallel, providing two voltage options. Two-piece heaters are rated at full voltage and 1/2 the total wattage for each half. On very large custom applications, Tempco may suggest going to multiple Mi-Plus heater segments with spring-loaded clamping.

One-Piece Expandable Band Construction

The expandable construction style allows the heater to be opened up and placed anywhere along the machine barrel, as well as minimizes the unheated area as compared to a two-piece heater.

With two heater circuits in a common case this heater naturally lends itself to a dual voltage system, a 240/480 volt package being the most common. When wired in parallel these heaters can run at 240 volts, and when wired in series, at 480 volts.

Expandable heaters are rated for each circuit at full voltage and one half of the total wattage.

Mi-Plus® Construction Styles — Special Variations

Partial Coverage Band 2-Piece with Built-In Brackets

Partial coverage band heaters are required when an obstruction on the barrel would interfere with a full coverage band.

The preferred method of construction is the 2-piece Band Heater with Built-In Brackets as illustrated below. The heater is bolted down to the cylinder at the ends and the built-in low thermal expansion strap pulls the heater tightly against the cylinder being heated. The standard center of hole to edge of heater dimension is 1/4".

When ordering, specify the angle of coverage from center to center of the mounting screw holes as shown.

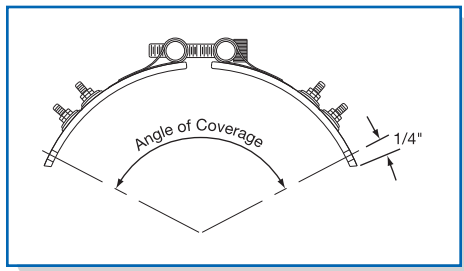

Partial Coverage Band 1-Piece with Separate Strap

The alternate method of partial coverage construction is the 1-piece Band Heater with a separate 2-piece strap.

The 2-piece strap itself is bolted at the padded ends, allowing the heater to float between the pads as illustrated below. When tightening the strap, it will pull the heater against the cylinder being heated. The standard center of hole to edge of heater dimension is 1/4".

When ordering, specify the angle of coverage from center to center of the mounting screw holes as shown.

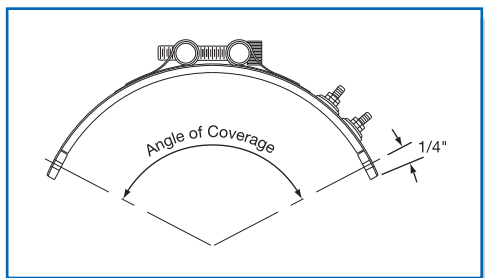

Clamping Variations

Mi-Plus® Standard Built-In Clamping Strap

The clamping brackets of the Mi-Plus Heater are formed from its outer sheath, producing a unique Built-In Strap. Clamping power is generated through barrel nuts and socket head cap screws, which are an integral part of the Built-In Strap.

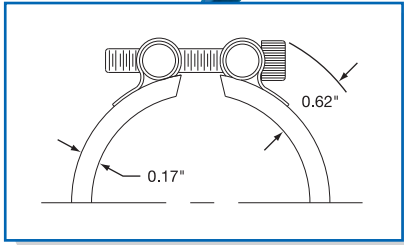
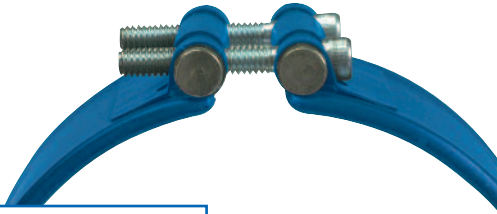

High operating temperatures require superior clamping force to maintain ultimate contact between the inside diameter of the band heater and the barrel, which is essential for maximum heater operating life. Only Tempco's Mi-Plus offers you this unique Built-In Strap feature.

TOUGH IN EXTREME CONDITIONS

Even under the most extreme conditions, the Built-In Strap Clamping will remain functional for the life of your Mi-Plus band heater. The steel clamping bars are the full width of the heater to distribute the forces evenly for superior heater contact. Tempco uses 1/4-20 alloy steel socket head cap screws to maximize the clamping power.

Standard on all Mi-Plus heaters 3" in diameter & larger

Limitations **Minimum Width:** 1-1/2" (38.1 mm)
Minimum Diameter: 3" (76.2 mm)

Type NB — One-Piece Band

Type NS — Two-Piece Band

Type NE — One-Piece Expandable Band

Consult Tempco for multiple segment heaters.

Mi-Plus Separate Clamping Straps



The Mi-Plus is available without built-in brackets. This option uses a separate strap to properly clamp the heater. A separate strap is useful when clearance is limited or there is an obstruction. Separate straps are made strictly to customer specifications. Consult Tempco with your requirements.

Bolt Size	Clearance	Suggested Diameter Range
8-32	.50"	1" – 3"
10-32	.56"	2" – 6"
1/4-20	.62"	> 3"



Note: The number of straps is dependent on heater width. Tempco recommends the use of the largest bolt size that clearance allows.

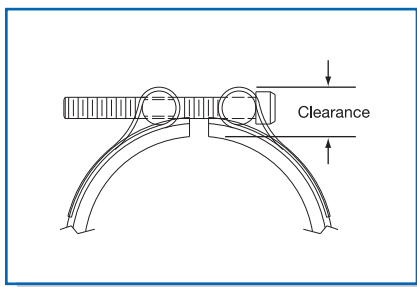

Type SB — One-Piece Band

Type SS — Two-Piece Band
(Requires Minimum Heater Diameter of 3")

Type SE — One-Piece Expandable Band
(Requires Minimum Heater Diameter of 3")

Consult Tempco for multiple segment heaters.

Mi-Plus® Built-In Clamping Strap Variations

Mi-Plus Low Profile Built-In Clamping Strap

When space is limited use Tempco's low profile clamping, a design that doesn't sacrifice strength for size. This compact design uses 10-32 alloy socket head cap screws.

Standard on all Mi-Plus heaters less than 3" in diameter

Limitations **Minimum Width:** 1-1/2" (38.1 mm)
Minimum Diameter: 1-3/8" (34.9 mm)

Type LB — One-Piece Band

Type LS — Two-Piece Band

Type LE — One-Piece Expandable Band

Consult Tempco for multiple segment heaters.

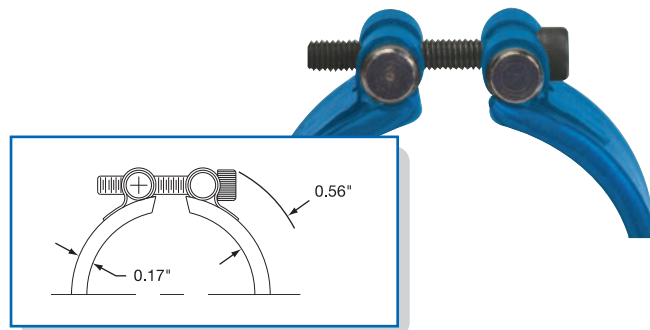

Mi-Plus Outrigger Built-In Clamping Strap

This design is unique to 1" wide heaters from 1-3/8" diameter and greater. Two 8-32 alloy socket head cap screws are used to give 1" wide heaters the required clamping power.

Standard on Mi-Plus heaters 1" wide and 1-3/8" in diameter and greater.

Type OB — One-Piece Band

Type OS — Two-Piece Band

Consult Tempco for multiple segment heaters.

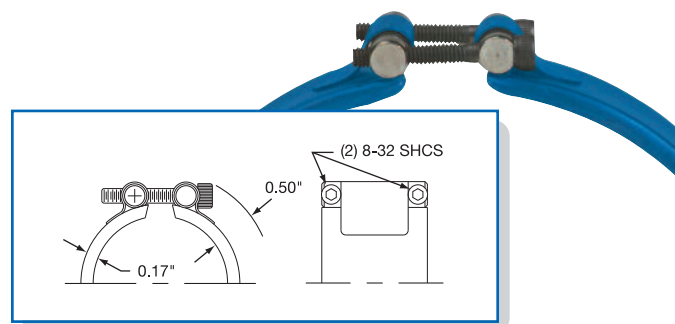

Mi-Plus Spring Loaded Built-In Clamping Strap

Spring loaded clamping with alloy steel socket head cap screws is standard on heaters over 8" in diameter and offered as an option on any heater with standard brackets. The extra heavy duty compression springs serve to combat thermal expansion of the heater by self adjustment, thereby ensuring excellent contact of the heater surface with the machine barrel or die. This type of clamping is also useful on heaters that are mounted vertically.

Limitations

Minimum Width: 1-1/2" (38.1 mm)

Minimum Diameter: 3-1/2" (88.9 mm)

Type SL — One-Piece Band

Type NSL — Two-Piece Band

Type NEL — One-Piece Expandable Band

Consult Tempco for multiple segment heaters.

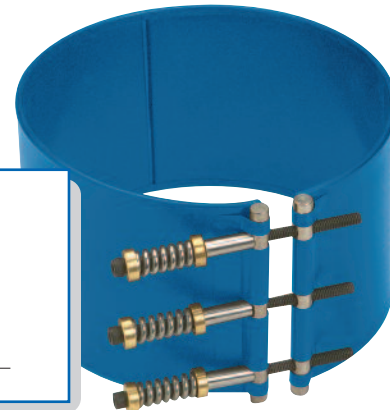
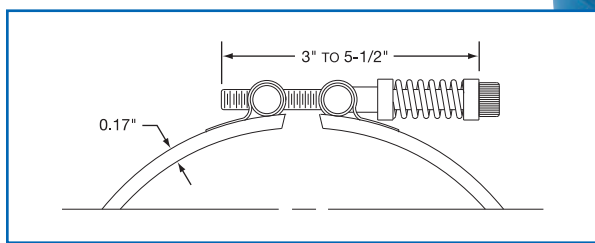

Mi-Plus Weld-On Bracket

The Mi-Plus is available without built-in brackets. For this option, brackets are welded onto the heater plate at user-specified locations. A weld-on bracket is useful when clearance is limited or there is an obstruction for using separate straps. Consult Tempco with your requirements.

Limitations **Minimum Width:** 1" (25.4 mm)

Minimum Diameter: 1" (25.4 mm)

Type WB — One-Piece Band

Type WS — Two-Piece Band

Type WE — One-Piece Expandable Band

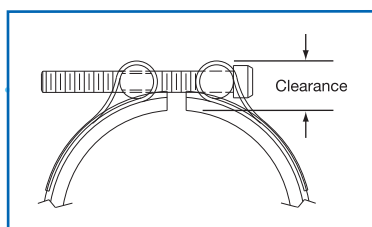

Bolt Size	Clearance
8-32	.50"
10-32	.56"
1/4-20	.62"



Note: The number of weld-on brackets is dependent on heater width. Tempco recommends the use of the largest bolt size that clearance allows.

Terminations

Screw Terminals: Type T2, Type T3X & Type T3Y

The specially designed Stainless Steel Power Terminals are internally connected to the heater and are resistant to over-torquing. The screw terminals are virtually unbreakable. Secure tightening of the electrical connections is essential for safety and long heater life.

Mi-Plus Type T2 — Screw Terminals

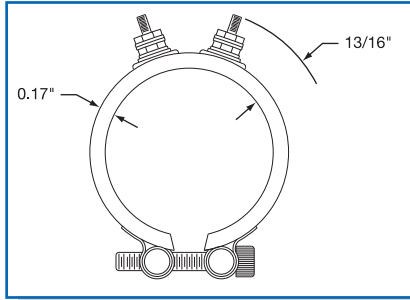

One-Piece Band

Standard Termination Location:
opposite the gap; center of width

- * **Minimum Inside Diameter:** 2-1/2" (63.5 mm)
- * **Minimum Width:** 1-1/2" (38.1 mm)
- * **Post Terminals:** 10-32 or 8-32
- * **Maximum Volts:** 480VAC
- * **Maximum Amps:** 25A (10-32) or 20A (8-32)



Only Tempco's Mi-Plus has these unique Torque-Resistant Power Terminals.

Two-Piece Band

Standard Termination Location:
center of each half; center of width

- * **Minimum Inside Diameter:** 3" (76.2 mm)
- * **Minimum Width:** 1-1/2" (38.1 mm)
- * **Post Terminals:** 10-32 or 8-32
- * **Maximum Volts/Amps:** 480VAC/ 25A (10-32) or 20A (8-32) each half

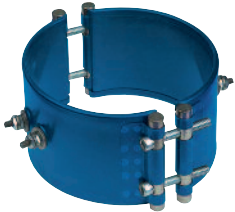

One-Piece Expandable Band

Standard Termination Location:
two sets of terminals opposite the gap; center of the width

- * **Minimum Inside Diameter:** 2-1/2" (63.5 mm)
- * **Minimum Width:** 1-1/2" (38.1 mm)
- * **Post Terminals:** 10-32 or 8-32
- * **Maximum Volts/Amps:** 480VAC/ 25A (10-32) or 20A (8-32) each half



Mi-Plus Type T3X — Screw Terminals

One-Piece Band

Standard Termination Location:
opposite the gap; across center of width

- * **Minimum Inside Diameter:** 2-1/2" (63.5 mm)
- * **Minimum Width:**
with 10-32 Post Terminals — 2-1/2" (63.5 mm)
with 8-32 Post Terminals — 2" (50.8 mm)
- * **Maximum Volts/Amps:** 480VAC/ 25A (10-32) or 20A (8-32) each half



One-Piece Expandable Band

Standard Termination Location:
two sets of terminals opposite the gap; across center of width

- * **Minimum Inside Diameter:** 2-1/2" (63.5 mm)
- * **Minimum Width:**
w/ 10-32 Post Terminals — 2-1/2" (63.5 mm)
w/ 8-32 Post Terminals — 2" (50.8 mm)
- * **Maximum Volts/Amps:** 480VAC/ 25A (10-32) or 20A (8-32) each half



Two-Piece Band

Standard Termination Location:
center of each half; across center of width

- * **Minimum Inside Diameter:** 3" (76.2 mm)
- * **Minimum Width:**
w/ 10-32 Post Terminals — 2-1/2" (63.5 mm)
w/ 8-32 Post Terminals — 2" (50.8 mm)
- * **Maximum Volts/Amps:** 480VAC/ 25A (10-32) or 20A (8-32) each half



Type T3Y — Screw Terminals, Next To Gap

Two-Piece Band

Standard Termination Location:
next to same gap on each half;
across center of width

- * **Minimum Inside Diameter:** 3" (76.2 mm)
- * **Minimum Width:**
with 8-32 Post Terminals — 2" (50.8 mm)
with 10-32 Post Terminals — 2-1/2" (63.5 mm)
- * **Maximum Volts:** 480VAC each half
- * **Maximum Amps:** 25A (10-32) or 20A (8-32) each half

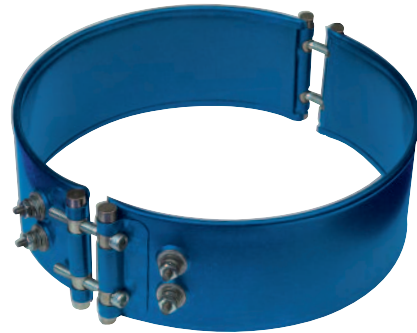

Note: Type T3Y is not available on One-Piece or One-Piece Expandable Mi-Plus Band Heaters

Optional Igloo™ Ceramic Covers for Heaters with Screw Terminals

Igloo™ ceramic terminal covers consist of two individual ceramic parts. With a tight-fitting cap and a solid base, an Igloo will fully insulate any standard #8 or #10 terminal lug used for electrical wiring hookups. Igloos can be assembled onto any standard Mi-Plus Band with 8-32 or 10-32 screw terminals. Igloo Double Port 90° are recommended on expandable heaters with Type T3X Termination. Igloo Double Port In-Line will not fit on expandable heaters with Type T3X termination.

Minimum Inside Diameter: 2-1/2" (63.5 mm)

Minimum Width: 2-1/2" (63.5 mm)

Three types of Igloo™ bases are available:

- Type C6** — Double Port In-Line P/N CER-101-104
- Type C7** — Double Port 90° P/N CER-101-106
- Type C8** — Single Port P/N CER-101-107

Igloo™ caps are available in the three screw terminal sizes:

- 10-32** — P/N CER-102-101
- 10-24** — P/N CER-102-104
- 8-32** — P/N CER-102-105

When ordering, specify the type of Igloo and the screw terminal size.

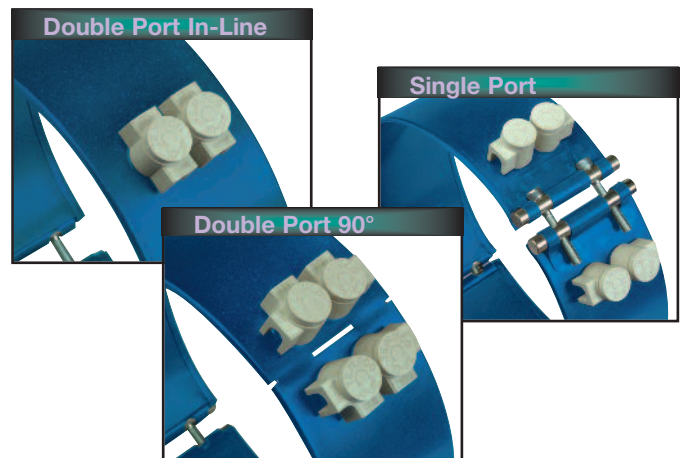

Exposed electrical wiring on band heater installations is a violation of Electrical Safety Codes including O.S.H.A.

Selection
TERMINATION
Guide

Terminations

Mi-Plus® Type W1 — Abrasion Resistant Straight Wire Braid Leads

The lead wires exit straight out through a stainless steel eyelet. Flexible stainless steel wire braid leads are highly recommended for improved abrasion resistance. Wire braid leads offer sharp bending not possible with armor cable.

This stainless steel braid is loosely wrapped around two mica insulated lead wires rated for 842°F (450°C). The standard leads are 10" of stainless steel loose wire braid over 12" of flexible leads. *If longer leads are required, specify when ordering.*

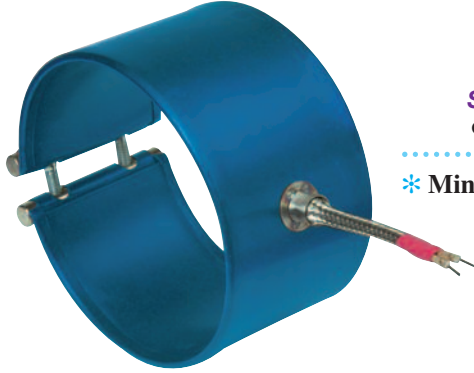

One-Piece Band

Standard Termination Location:
opposite the gap; center of width

- * **Minimum Inside Diameter:** 1" (25.4 mm)
- * **Minimum Width:** 1" (25.4 mm)
- * **Maximum Volts:** 480VAC
- * **Maximum Amps:** 10

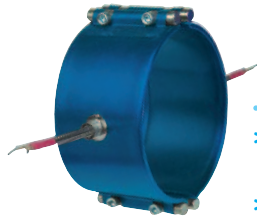
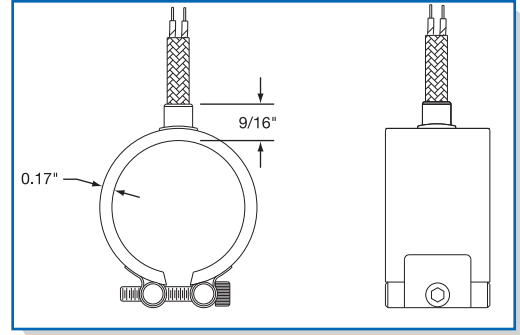

Two-Piece Band

Standard Termination Location:
center of each half; center of width

- * **Minimum Inside Diameter:**
3" (76.2 mm)
- * **Minimum Width:** 1" (25.4 mm)
- * **Maximum Volts:** 480VAC each half
- * **Maximum Amps:** 10 each half

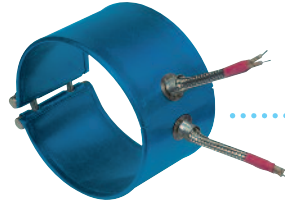

One-Piece Expandable Band

Standard Termination Location:
two sets of leads opposite the gap;
center of width

- * **Minimum Inside Diameter:**
2-1/2" (63.5 mm)
- * **Minimum Width:** 1-1/2" (38.1 mm)
- * **Maximum Volts/Amps:**
480VAC/10A each half

Mi-Plus Type W2 — Right-Angle Wire Braid Leads, 90 Degrees to Heater Diameter

This style of wiring is the most prevalent for nozzle band heaters, as it contributes to the most flexible and space saving installation.

Mica insulated lead wires rated for 842°F (450°C) with tightly wrapped stainless steel overbraid are used, providing protection in abrasive environments. The stainless steel braid exits parallel to the heater centerline through a low profile stainless steel cap. This cap also acts as a strain relief, guarding against excessive flexing or pulling of the lead wire.

This termination style is located 180° from the gap for one-piece heaters and 90° from the gap for two-piece heaters and exits the heater near the edge. By keeping the lead wires away from the heater, less damage from high temperature contact is likely to occur.

The standard leads are 10" of stainless steel wire braid over 12" of flexible leads. *If longer leads are required, specify when ordering.*

One-Piece Band

Standard Termination Location:
opposite the gap; near edge of width

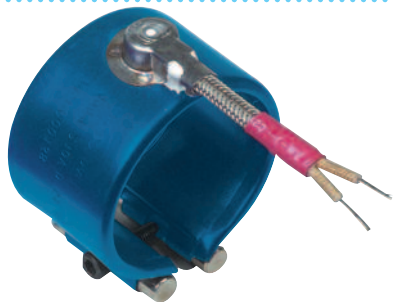

- * **Minimum Inside Diameter:** 1" (25.4 mm)
- * **Minimum Width:** 1" (25.4 mm)
- * **Maximum Volts:** 480VAC
- * **Maximum Amps:** 10

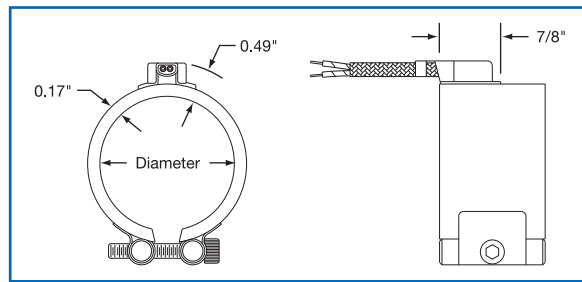

LOW PROFILE

ABRASION RESISTANT

LEAD TERMINATIONS

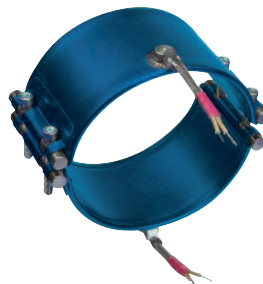

Two-Piece Band

Standard Termination Location:
center of each half; near edge of width

- * **Minimum Inside Diameter:** 3" (76.2 mm)
- * **Minimum Width:** 1" (25.4 mm)
- * **Maximum Volts/Amps:**
480VAC/10A each half

Mi-Plus® Type W5 — Right-Angle Wire Braid Leads, 90 Degrees to Heater Width

The stainless steel braid exits parallel to the heater surface through a low profile stainless steel cap, which also acts as a strain relief guarding against excessive flexing or pulling of the lead wire. Mica insulated lead wires rated for 842°F (450°C) with tightly wrapped stainless steel over-braid are used, providing protection in abrasive environments.

This low-profile termination is convenient where space limitations are a concern.

The standard leads are 10" of stainless steel wire braid over 12" of flexible leads. *If longer leads are required, specify when ordering.*

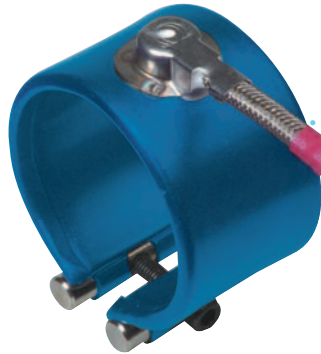
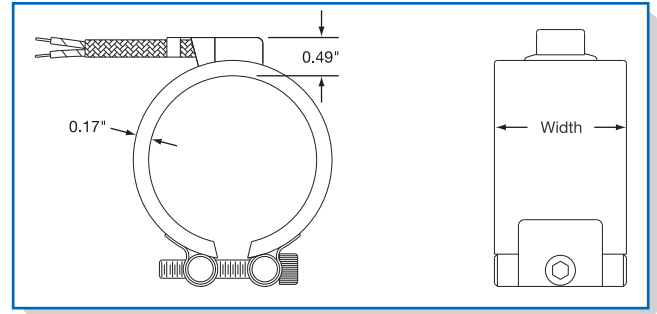

One-Piece Band

Standard Termination Location:
opposite the gap; center of width

- * Minimum Inside Diameter: 1" (25.4 mm)
- * Minimum Width: 1" (25.4 mm)
- * Maximum Volts: 480VAC
- * Maximum Amps: 10

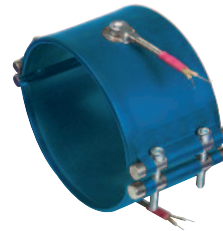

Two-Piece Band

Standard Termination Location:
center of each half; center of width

- * Minimum Inside Diameter: 3" (76.2 mm)
- * Minimum Width: 1" (25.4 mm)
- * Maximum Volts: 480VAC each half
- * Maximum Amps: 10 each half

Mi-Plus Type R1 — Abrasion Resistant Straight Armor Cable

Stainless steel armor cable provides vastly superior lead wire protection in cases where abrasion is a constant problem. The lead wires are mica insulated and rated for 842°F (450°C).

The standard leads are 10" of stainless steel armor cable over 12" lead wire.

If longer leads are required, specify when ordering.

Selection TERMINATION Guide

One-Piece Band

Standard Termination Location:
opposite the gap; center of width

- * Minimum Inside Diameter: 1" (25.4 mm)
- * Minimum Width: 1" (25.4 mm)
- * Maximum Volts: 480VAC
- * Maximum Amps: 10

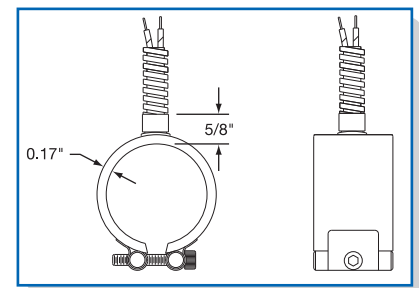
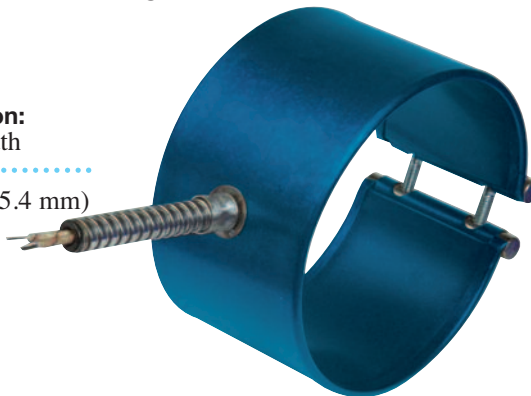

Two-Piece Band

Standard Termination Location:
center of each half; center of width

- * Minimum Inside Diameter: 3" (76.2 mm)
- * Minimum Width: 1" (25.4 mm)
- * Maximum Volts/Amps: 480VAC/10A each half

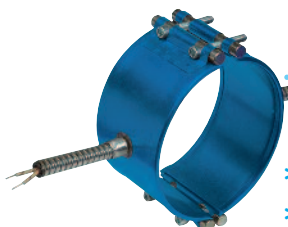

One-Piece Expandable Band

Standard Termination Location:
two sets of leads opposite the gap;
center of width

- * Minimum Inside Diameter: 2-1/2" (63.5 mm)
- * Minimum Width: 1-1/2" (38.1 mm)
- * Maximum Volts/Amps: 480VAC/10A each half

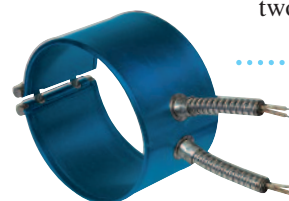

Terminations

Mi-Plus® Type R2B — Abrasion Resistant Right-Angle Armor Cable

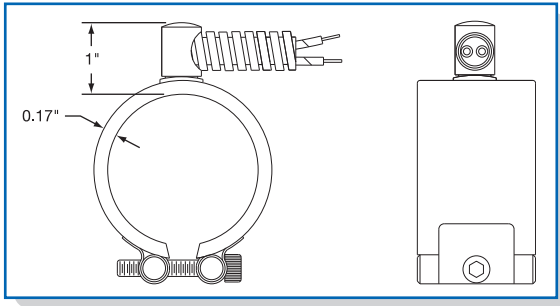

One-Piece Band

Standard Termination Location:
opposite the gap; center of width

- * **Minimum Inside Diameter:**
1" (25.4 mm)
- * **Minimum Width:** 1" (25.4 mm)
- * **Maximum Volts/Amps:**
480VAC/10A

Stainless Steel Right-Angle Armor Cable will provide excellent lead wire protection. This space saving termination will give long-term abrasion protection. The lead wires are mica insulated and rated for 842°F (450°C).

The standard leads are 10" of stainless steel armor cable over 12" of lead wire.
If longer leads are required, specify when ordering.

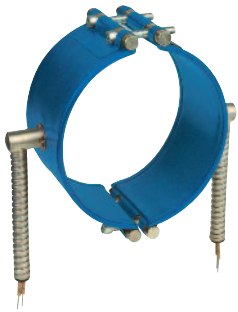

Two-Piece Band

Standard Termination Location:
center of each half; center of width

- * **Minimum Inside Diameter:**
3" (76.2 mm)
- * **Minimum Width:** 1" (25.4 mm)
- * **Maximum Volts/Amps:**
480VAC/10A each half

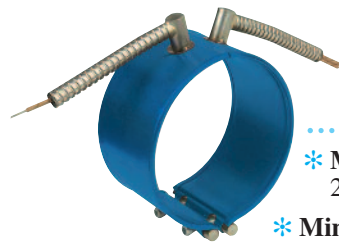

One-Piece Expandable Band

Standard Termination Location:
two sets of leads opposite the gap;
center of width

- * **Minimum Inside Diameter:**
2-1/2" (63.5 mm)
- * **Minimum Width:** 1-1/2" (38.1 mm)
- * **Maximum Volts/Amps:**
480VAC/10A each half

Mi-Plus Type R2H — Abrasion Resistant Right-Angle Armor Cable for Type HTL Lead Wire

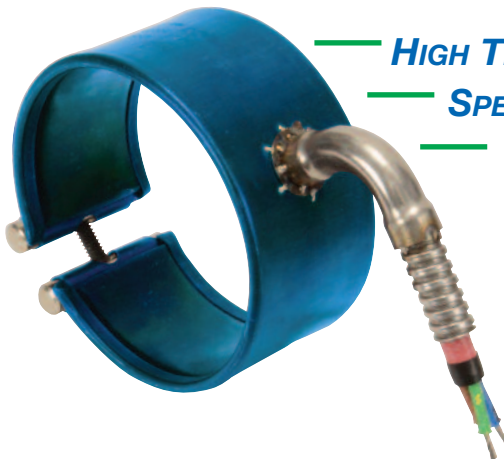
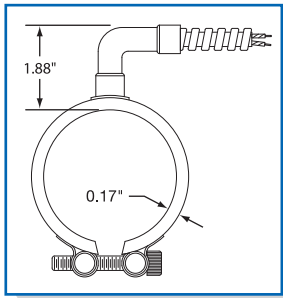

HIGH TEMPERATURE TERMINATION: 1022°F (550°C)

SPECIAL SS RIGHT-ANGLE FITTING

3-CONDUCTOR WIRE

One-Piece Band

Standard Termination Location:
opposite the gap; center of width

- * **Minimum Inside Diameter:** 1-1/2" (38.1 mm)
- * **Minimum Width:** 1" (25.4 mm)
- * **Maximum Volts/Amps:** 480VAC/10A

Two-Piece Band

Standard Termination Location:
center of each half;
center of width

- * **Minimum Inside Diameter:**
3" (76.2 mm)
- * **Minimum Width:**
1" (25.4 mm)
- * **Maximum Volts/Amps:**
480VAC/10A each half

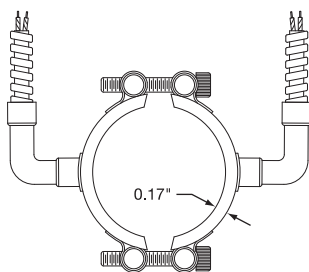

One-Piece Expandable Band

Standard Termination Location:
two sets of leads opposite the gap;
center of width

- * **Minimum Inside Diameter:**
2-1/2" (63.5 mm)
- * **Minimum Width:**
1-1/2" (38.1 mm)
- * **Maximum Volts/Amps:**
480VAC/10A each half

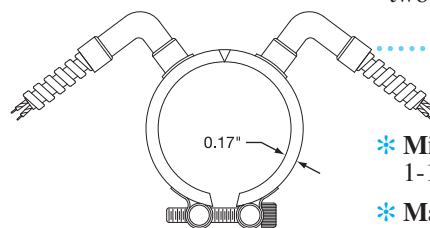

View Product Inventory @ www.tempco.com

Mi-Plus® Type C — General Purpose Terminal Box

General purpose terminal boxes are a simple & economical way to protect employees from electric shock or prevent electric shorts that can result from exposed wiring on band heater electrical installations.

The Heavy Duty Stainless Steel Terminal Box has a 1/2" trade size knockout (actual diameter 7/8") that will accept standard armor cable connectors. To simplify installation, Mi-Plus band heaters with terminal boxes can be pre-wired.

Type CA – Box only (*shown*)

Type CD – Box with prewired SS wire braid

Type CC – Box with prewired SS armor cable

Type CE – Box with prewired plain leads

The standard abrasive protection leads are 10" of protection over 12" of flexible leads. The standard lead length for plain leads is 10" long.

If longer leads are required, specify when ordering.

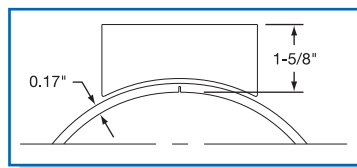

Box: One-Piece Expandable Construction

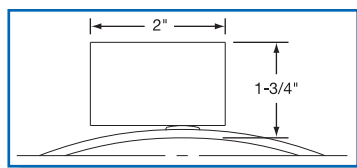

Box: One-Piece & Two-Piece Construction



One-Piece Band

Standard Termination Location: opposite the gap; center of width

- * **Minimum Inside Diameter:** 3" (76.2 mm)
- * **Minimum Width:** 2" (50.8 mm)
- * **Maximum Volts/Amps:** 480VAC/25A

Two-Piece Band

Standard Termination Location: center of each half; center of width

- * **Minimum ID:** 3" (76.2 mm)
- * **Minimum Width:** 2" (50.8 mm)
- * **Maximum Volts/Amps:** 480VAC/25A each half



One-Piece Expandable Band

Standard Termination Location: opposite the gap; center of width

- * **Minimum ID:** 3" (76.2 mm)
- * **Minimum Width:** 2" (50.8 mm)
- * **Maximum Volts/Amps:** 480VAC/25A each half

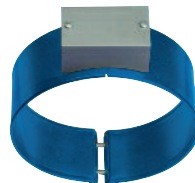

Selection TERMINATION Guide

Mi-Plus Type L1 — Plain Wire Leads

Plain wire leads are available on all construction styles. The lead wires exit straight out through a stainless steel eyelet. High-temperature 842°F (450°C) mica insulated lead wire is standard. The standard lead length is 10" long. *If longer leads are required, specify when ordering.*

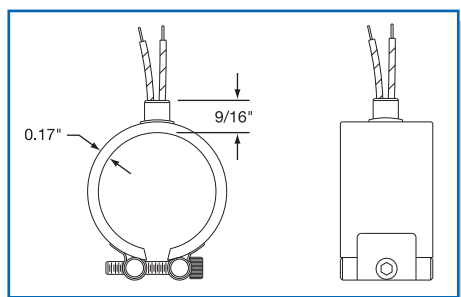

One-Piece Band

Standard Termination Location: opposite the gap; center of width

- * **Minimum Inside Diameter:** 1" (25.4 mm)
- * **Minimum Width:** 1" (25.4 mm)
- * **Maximum Volts/Amps:** 480VAC/10A



Note: Plain wire leads do not offer protection against contamination or abrasion.

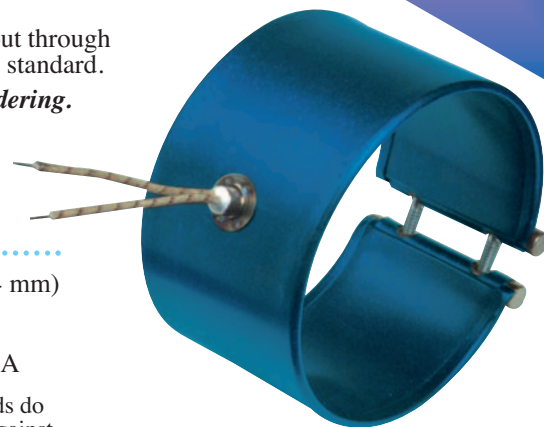

Two-Piece Band

Standard Termination Location: center of each half; center of width

- * **Minimum Inside Diameter:** 3" (76.2 mm)
- * **Minimum Width:** 1" (25.4 mm)
- * **Maximum Volts/Amps:** 480VAC/10A each half



One-Piece Expandable Band

Standard Termination Location: two sets of leads opposite the gap; center of width

- * **Minimum Inside Diameter:** 2-1/2" (63.5 mm)
- * **Minimum Width:** 1-1/2" (38.1 mm)
- * **Maximum Volts/Amps:** 480VAC/10A each half

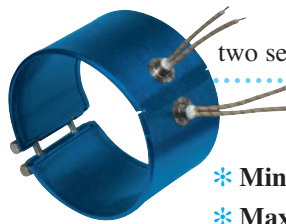

Mi-Plus® Type P1 — High Temperature Quick Disconnect Plugs

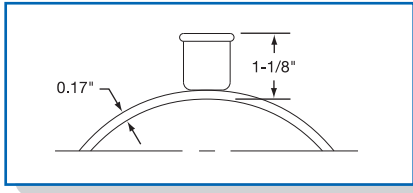

Cup Assembly Only

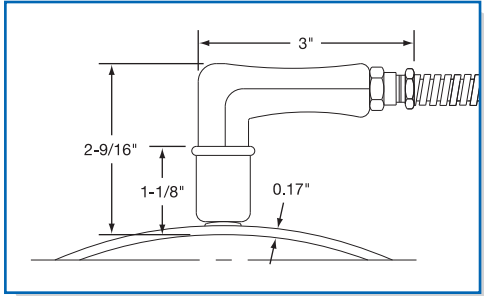

Cup Assembly with 90° Plug

High Temperature Quick Disconnects are a simple, safe and quick way to apply power to a band heater installation. The combination of plug and cup assembly along with stainless steel armor cable or stainless steel wire braid eliminates all live exposed terminals or wiring that can be a potential hazard. The assembly is available with a straight or right-angle plug. To simplify installation, Mi-Plus band heaters with Quick Disconnects can be pre-wired with stainless steel armor or stainless steel wire braid.

- P1A** — Cup Assembly only
- P1B** — Cup Assembly with straight plug
- P1C** — Cup Assembly with 90° plug
- P1E** — Cup Assembly with straight plug and stainless steel armor cable
- P1F** — Cup Assembly with straight plug and stainless steel wire braid
- P1H** — Cup Assembly with 90° plug and stainless steel armor cable
- P1J** — Cup Assembly with 90° plug and stainless steel wire braid

The standard abrasive protection leads are 10" of protection over 12" of flexible leads. *If longer leads, armor cable or braid are required, specify when ordering.*

Type P1A Shown

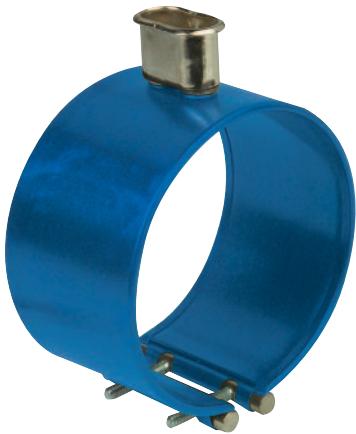

One-Piece Band

Standard Termination Location:
opposite the gap; center of width

- * **Minimum Inside Diameter:** 3" (76.2 mm)
- * **Minimum Width:** 2" (50.8 mm)
- * **Maximum Volts:** 250VAC
- * **Maximum Amps:** 16
- * **Maximum Temperature:** 572°F (300°C)

Type P1H Shown



Type P1A Shown



Two-Piece Band

Standard Termination Location:
center of each half; center of width

- * **Minimum Inside Diameter:** 3" (76.2 mm)
- * **Minimum Width:** 2" (50.8 mm)
- * **Maximum Volts:** 250VAC each half
- * **Maximum Amps:** 16 each half
- * **Maximum Temperature:** 572°F (300°C)

Type P1H Shown



Note: Type P1 is not available on One-Piece Expandable Mi-Plus Band Heaters

Mi-Plus® Type P2 — Terminal Box and High Temperature Quick Disconnect Straight Plug

This lower profile terminal box and high temperature quick disconnect plug assembly offers a solution where clearance is a problem. The combination of plug and cup assembly along with stainless steel armor cable or stainless steel wire braid eliminates all live exposed terminals or wiring that can be a potential hazard.

The assembly is available with straight plug only. To simplify installation, Mi-Plus band heaters with Quick Disconnects can be pre-wired with stainless steel armor or stainless steel wire braid.

P2A — Box and Cup only

P2B — Box and Cup with straight plug

P2D — Box and Cup with straight plug and stainless steel armor cable

P2E — Box and Cup with straight plug and stainless steel wire braid

The standard abrasive protection leads are 10" of protection over 12" of flexible leads.

If longer leads, armor cable or braid are required, specify when ordering.

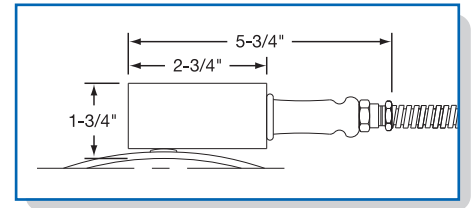

Box – One- & Two-Piece Construction

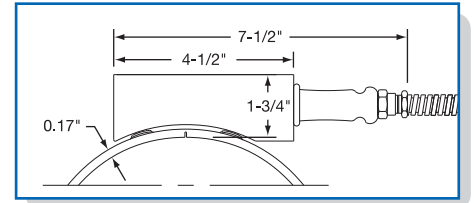

Box – One-Piece Expandable Construction

One-Piece Band

Standard Termination Location:
opposite the gap; center of width

Type P2D Shown



- * **Minimum Inside Diameter:** 3" (76.2 mm)
- * **Minimum Width:** 2" (50.8 mm)
- * **Maximum Volts:** 250VAC
- * **Maximum Amps:** 16
- * **Maximum Temperature:** 572°F (300°C)

Type P2A Shown



Selection
TERMINATION
Guide

Two-Piece Band

Standard Termination Location:
center of each half; center of width

Type P2D Shown



- * **Minimum Inside Diameter:** 3" (76.2 mm)
- * **Minimum Width:** 2" (50.8 mm)
- * **Maximum Volts:** 250VAC each half
- * **Maximum Amps:** 16 each half
- * **Maximum Temperature:** 572°F (300°C)

Type P2A Shown



Type P2D Shown

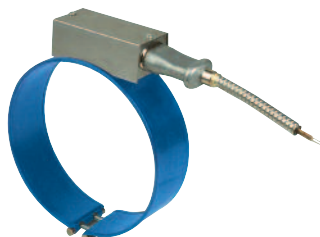

One-Piece Band Expandable

Standard Termination Location:
opposite the gap; center of width

- * **Minimum Inside Diameter:** 3" (76.2 mm)
- * **Minimum Width:** 2" (50.8 mm)
- * **Maximum Volts:** 250VAC each half
- * **Maximum Amps:** 16 each half
- * **Maximum Temperature:** 572°F (300°C)

Type P2A Shown



Features/Options

Thermocouple Coupling

The Thermocouple Coupling facilitates the installation of an external thermocouple with a threaded fitting. The standard location for the coupling is 90° from the gap at the center of the width. Specify without through hole for heater sensing or with through hole for load sensing.

The bushing sizes available are:

Thread	D	H
1/8-27 NPT	9/16"	5/8"
1/4-20 NPT	3/4"	11/16"
3/8-18 NPT	7/8"	5/8"
M12-1.75mm	3/4"	1/2"

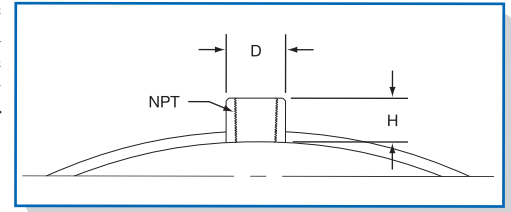

Note: The minimum heater width with a coupling is 1-1/2". If heater width is smaller than 1-1/2", heater gap will be used for coupling location.



Thermocouple Bayonet Adapter

A standard Bayonet Adapter facilitates the installation of an external thermocouple with a standard bayonet cap. The standard location for the adapter is 90° from the gap.

Refer to pages 14-3 and 14-4 for a complete selection of thermocouples available from stock.

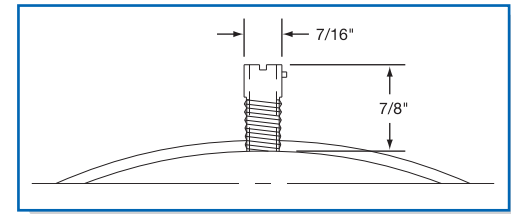

Note: The minimum heater width with a T/C adapter is 1-1/2". If heater width is smaller than 1-1/2", heater gap will be used for T/C location.



Built-In Thermocouple

A built-in thermocouple can be factory installed on Mi-Plus band heaters. ANSI type J or K thermocouples are available on Type L1, R,1 R2, W1, W2 and W5 lead wire terminations. Thermocouple junction is located inside the exit termination stamping, providing a relative heater temperature.

Thermocouple can be located in various positions on the heater. Consult Tempco with your requirements.

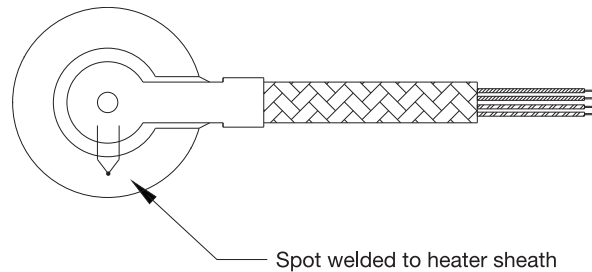

Stock Heavy Duty Quick Disconnect Plugs and Connectors

Heaters with pre-wired plugs allow quick and easy installation of the heater. These plugs can be attached to armor cable or stainless steel wire braid.

For other types of plugs, consult Tempco or specify the manufacturer's part number when ordering.

See page 15-15 for additional Twist-Lock electrical plugs.

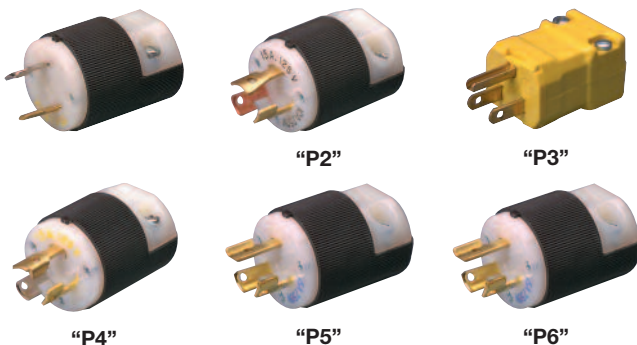

Reference	NEMA P or R	Amps	Volts	Plug Part No.	Connectors (Female) Part No.
P1 twist lock	L1-15	15A	125V	EHD-102-102	EHD-103-101
P2 twist lock	N/A	10A 15A	250V 125V	EHD-102-107	EHD-103-103
P3 straight	5-15	15A	125V	EHD-102-103	EHD-103-102
P4 twist lock	L5-15	15A	125V	EHD-102-113	EHD-103-104
P5 twist lock	L6-15	15A	250V	EHD-102-121	EHD-103-107
P6 twist lock	L6-20	20A	250V	EHD-102-122	EHD-103-150

View Product Inventory @ www.tempco.com

Installation RECOMMENDATIONS

1. Disconnect electric power to the machine and/or heaters prior to installing or replacing heaters.
2. Do not install heaters in areas where combustible gases, vapor, or dust is present.
3. Use a heater that closely matches the wattage requirements. This will decrease the frequency of cycling and temperature overshoot, thereby increasing the life of the heater.
4. Make certain that all barrel surfaces are clean and have a smooth finish. Any contaminants or imperfections on the surface can cause premature heater failure.
5. Tempco expandable type Mi-Plus Band Heaters may be opened once at the gap, to fit on the barrel. Do not open these heaters beyond their specified heater diameter.



Do not open Tempco One-Piece Non-Expandable Type Mi-Plus Band Heaters. Opening of these heaters can cause internal damage

6. Position heater bands on the barrel.
7. Securely tighten heater bands around the barrel. Clamping force must be equally distributed on heaters with more than one set of clamping brackets.
*Recommended Clamping Bolt Torque:
10 ft./lbs. (13.6 Newton/meters)*
8. For heaters with screw terminals, remove the top nut and flat washers from the power screw terminals. Do not loosen or remove the bottom nut on the screw terminals. The bottom nut is tightened to 60 inch/lbs. at our factory. A loose bottom nut can cause internal elements to shift and will result in premature heater failure.

Installation Accessories Available

IMMEDIATE DELIVERY!

- * High Temperature Terminal Lugs
- * Igloo Ceramic Insulating Covers
- * UL Listed Plugs
- * High Temperature Lead Wire 842°F (450°C)
- * Armor Cable
- * Stainless Steel Braid
- * High Temperature Sleeving
- * High Temperature Mica Insulated Wiring Harnesses 842°F (450°C)
- * High Temperature Mica Insulated Wiring Harnesses 1022°F (550°C)
- * Thermocouples
- * Temperature Controllers
- * High Temperature Fiberglass Tape

All Items Available from Stock

9. All electrical wiring of heater bands should be done by a qualified electrician using proper, dry, personal protective equipment.

- a. Use only Stainless Steel or other high temperature lugs to prevent material degradation when exposed to high temperatures over a prolonged period of time.



DO NOT USE COPPER OR PLATED COPPER LUGS.

- b. Heaters must be wired using the proper gauge wire with a minimum temperature rating of 842°F (450°C). All Mi-Plus Heaters supplied with lead wire terminations or factory pre-wired screw terminals use mica insulated lead wires rated to 842°F (450°C). **Never allow lead wires to lie directly on the heater surface. This can cause degradation of the lead wires and cause a short circuit.**

- c. When connecting power leads to screw terminals make certain that barrels of terminal lugs are not facing down toward the heater case, which will create a short circuit.

*Recommended Screw Terminal Torque:
30 in./lbs. (3.4 Newton/meters)*

- d. Make certain power lead wires do not make contact with hot heater surfaces to avoid degradation of lead wire, as this can cause electrical short circuits.
- e. Ensure that leads are not kinked or sharply bent around other obstructions.
- f. Make sure the voltage input to the heater bands does not exceed the voltage rating that is stamped on the heater bands.
- g. It is recommended that an amperage reading is taken for each heater to verify proper wiring. (Amps = Watts/Volts)

10. Insulate all live electrical wires per applicable safety standards.

11. Begin heater band re-tightening procedure. Be sure to wear protective gloves.

- a. Energize heater bands and allow the heater sheath to reach 400°F (usually 3–5 minutes).

- b. Turn power off and immediately re-tighten the Mi-Plus Bands to 10 ft./lbs. Turn power on.

12. Install shrouds around the machine to meet applicable safety requirements.

13. Once installed, check surroundings to make sure that contaminants won't get on the heater while the unit is in operation. Accumulation of contaminants on heaters can cause premature heater failure.

14. Insulating blanket installations must have band heater retightening sequence (#12) completed before blanket installation. Lead wires must exit the insulation blanket as soon as possible; do not entrap lead wires between heater sheath and insulation blanket.



It is imperative that upon start-up of new machines at customer facilities, all of the aforementioned parameters are double checked by qualified field service personnel.

Exposed electrical wiring on band heater installations is a violation of Electrical Safety Codes including O.S.H.A.

DURABAND*

with **BUILT-IN STRAP**

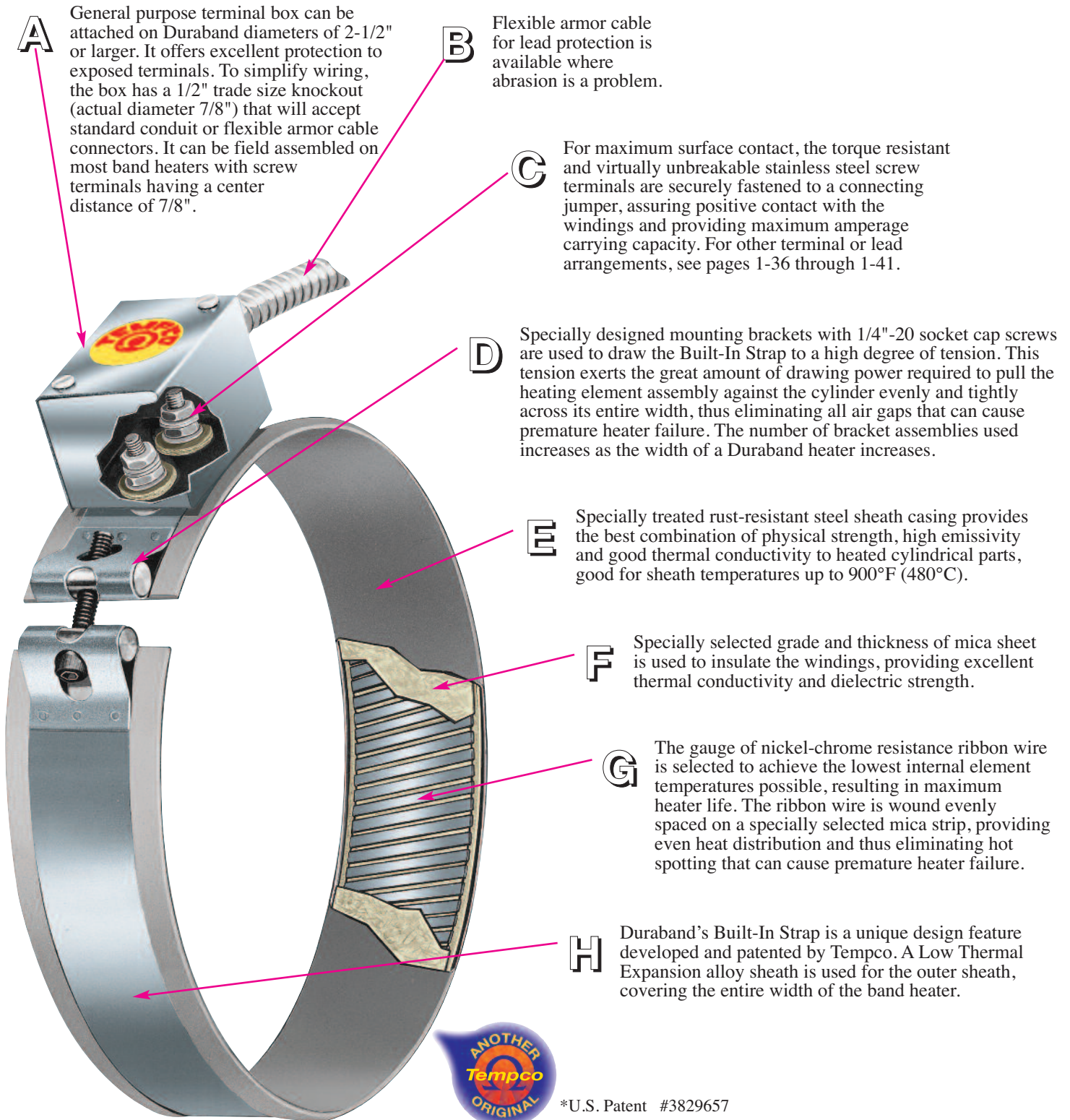

A General purpose terminal box can be attached on Duraband diameters of 2-1/2" or larger. It offers excellent protection to exposed terminals. To simplify wiring, the box has a 1/2" trade size knockout (actual diameter 7/8") that will accept standard conduit or flexible armor cable connectors. It can be field assembled on most band heaters with screw terminals having a center distance of 7/8".

B Flexible armor cable for lead protection is available where abrasion is a problem.

C For maximum surface contact, the torque resistant and virtually unbreakable stainless steel screw terminals are securely fastened to a connecting jumper, assuring positive contact with the windings and providing maximum amperage carrying capacity. For other terminal or lead arrangements, see pages 1-36 through 1-41.

D Specially designed mounting brackets with 1/4"-20 socket cap screws are used to draw the Built-In Strap to a high degree of tension. This tension exerts the great amount of drawing power required to pull the heating element assembly against the cylinder evenly and tightly across its entire width, thus eliminating all air gaps that can cause premature heater failure. The number of bracket assemblies used increases as the width of a Duraband heater increases.

E Specially treated rust-resistant steel sheath casing provides the best combination of physical strength, high emissivity and good thermal conductivity to heated cylindrical parts, good for sheath temperatures up to 900°F (480°C).

F Specially selected grade and thickness of mica sheet is used to insulate the windings, providing excellent thermal conductivity and dielectric strength.

G The gauge of nickel-chrome resistance ribbon wire is selected to achieve the lowest internal element temperatures possible, resulting in maximum heater life. The ribbon wire is wound evenly spaced on a specially selected mica strip, providing even heat distribution and thus eliminating hot spotting that can cause premature heater failure.

H Duraband's Built-In Strap is a unique design feature developed and patented by Tempco. A Low Thermal Expansion alloy sheath is used for the outer sheath, covering the entire width of the band heater.



*U.S. Patent #3829657

makes handling and installation easier!

Typical Applications

- ↪ *Plastic Injection Molding Machines*
- ↪ *Plastic Extruders*
- ↪ *Oil Reclamation Equipment*
- ↪ *Food and Candy Extruders*
- ↪ *Drum Heating*
- ↪ *Extrusion Dies*
- ↪ *Holding Tanks*
- ↪ *Blow Molding Machines*
- ↪ *Vending Machines*
- ↪ *Barrels & Heads*
- ↪ *Food Service Warming*
 - ↪ *Autoclaves & Sterilizers*
 - ↪ *Metallurgical Analyzers*
 - ↪ *Fluidized Beds*
- ↪ *Hot Runner Molds*
- ↪ *Pulp and Paper Processing Equipment*

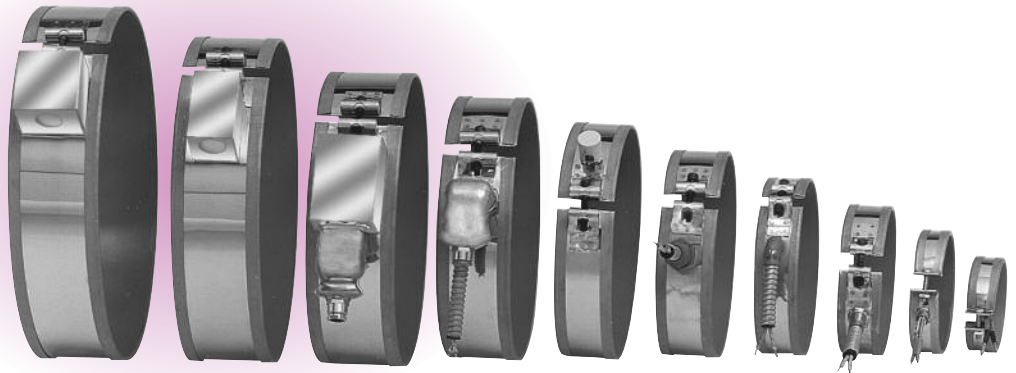

Designed For Trouble-Free Service

Tempco's Duraband heater design is the result of many years of research, development and testing for a reliable mica insulated band heater that can perform at the higher operating temperatures [up to 900°F (480°C)] essential to process high temperature resins, providing long, efficient service necessary for today's high productivity of plastic extruders, injection and blow molding machines.

Duraband is a proven heater design for good life efficiency and dependability. It assures maintaining the lowest winding temperatures possible, keeping a low-mass heating element assembly for fast heat-up and quick thermal response to controls. It incorporates the Low Thermal Expansion Built-In Strap, a unique design feature originally developed and patented by Tempco.

Advantages and Variations

Duraband mica insulated heaters are widely used on operations involving heating of cylindrical surfaces and are manufactured in a full range of standard construction variations, physical dimensions, electrical ratings, and a complete arrangement of screw terminals and lead terminations. (See pages 1-36 through 1-41).

However, these standard Duraband heater variations and terminations do not represent the full extent of our capabilities. Tempco's engineering staff, with many years of experience in heat processing and temperature control applications, can assist you in designing the right Duraband heater for your specific application.

Construction Characteristics & Features

- * *Built-in bracket for superior clamping*
- * *Unbreakable and torque-resistant screw terminals*
- * *Temperatures up to 900°F (480°C)*
- * *Full width stainless steel built-in strap*
- * *Flexibility to incorporate holes and cutouts*
- * *Available two-piece and expandable designs*
- * *Best mica insulated heater on the market*
- * *Faster delivery than any other type of heater band*
- * *Most economical among various heater bands*
- * *Most versatile and commonly used heater band*

Duraband Specifications

Duraband® Standard Specifications and Tolerances

PERFORMANCE RATINGS

Maximum Temperature: Standard Sheath: 900°F (482°C)
Nominal Watt Density: 20-45 W/in² (3-7 W/cm²)
Maximum Watt Density: Dependent on heater size and operating temperature.

ELECTRICAL RATINGS

Maximum Voltage: 480 VAC
Dual Voltage or 3-Phase:
 Available depending on heater design
Maximum Amperage: lead wire termination: 10 amp
 screw terminations: 8-32UNF—20 amp; 10-32UNF—25 amp
Resistance Tolerance: +10%, -5%
Wattage Tolerance: +5%, -10%



Exposed electrical wiring on band heater installations is a violation of Electrical Safety Codes including O.S.H.A.

PHYSICAL SIZE CONSTRUCTION LIMITATIONS

Minimum Width: 3/4" (19.1 mm)
Width Tolerance: ±1/16" (1.59 mm)
Minimum Inside Diameter: 7/8" (22.1 mm)
Nominal Gap: 3/8" (9.5 mm)—If a larger gap is required for probes or thermocouples, specify when ordering.

BUILT-IN BRACKETS

Heater Width	Number of Brackets
1-1/2" to 3" (38-76 mm)	1
3-1/8" to 5" (79-127 mm)	2
5-1/8" to 6-7/8" (130-145 mm)	3
7" to 10" (178-254 mm)	4
10-1/8" to 15" (257-381 mm)	5

If tighter tolerances are required, consult Tempco.

Minimum ID and Width for Construction/Clamping Styles

Style	Min. ID		Min. Width	
	in	mm	in	mm
NB	2	50.8	1-1/4	31.8
NS	3	76.2	1-1/4	31.8
NE	2-1/2	63.5	1-1/4	31.8
SB	7/8	22.1	3/4	19.1
SS	2	50.8	3/4	19.1
SE	2-1/2	63.5	1-1/4	31.8
FB	1	25.4	3/4	19.1
FS	2	50.8	3/4	19.1
FE	2-1/2	63.5	1-1/4	31.8
SL	4	101.6	1-1/4	31.8
NSL	4	101.6	1-1/4	31.8
NEL	4	101.6	1-1/4	31.8
LT	7	177.8	1-1/2	38.1
LS	7	177.8	1-1/2	38.1
LE	7	177.8	1-1/2	38.1
TWL	1	25.4	1	25.4
RNB	5-1/2	134.7	1	25.4
RNS	10	254	1	25.4



Note: Refer to individual descriptions for further information. Actual heater minimums will be a combination of termination and construction/strap styles.

Duraband® Maximum Watt Densities

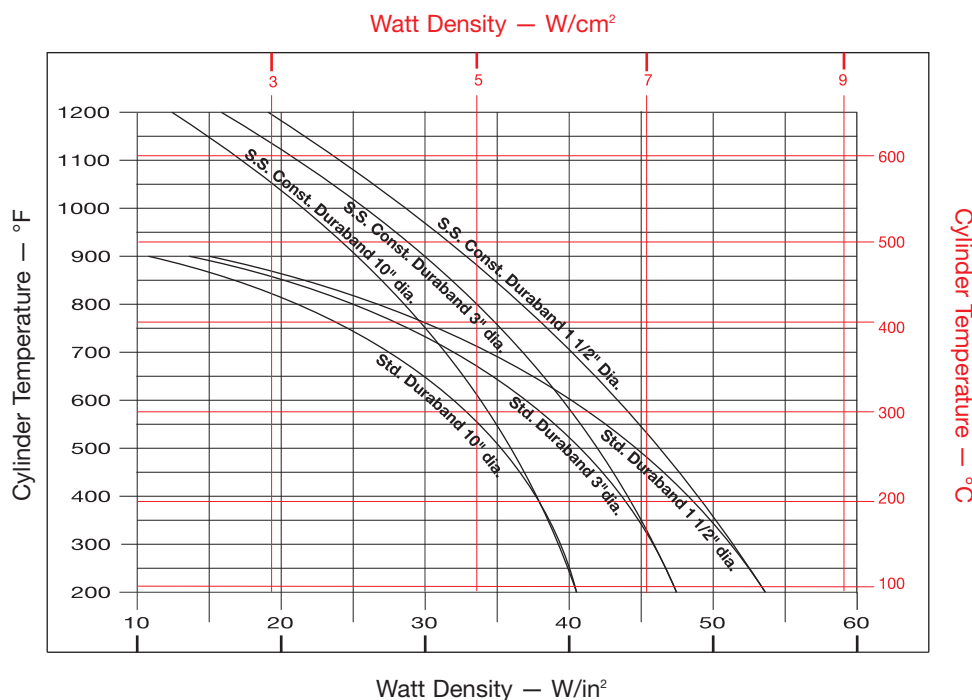

MAXIMUM ALLOWABLE WATT DENSITY

The chart displays the maximum Watt Density curves for various diameter heaters. Use this chart when determining the appropriate wattage value for your chosen heater.

Be aware that certain factors will require you to derate the watt density (W/in²) of your heater selection.

CAUTION Failure to adhere to the maximum allowable watt density per heater size will result in poor operating life.

CORRECTION FACTORS

For heaters wider than 3" (76.2 mm), reduce maximum recommended watt density from chart by 20%.

For applications using insulating shroud, reduce maximum recommended watt density from chart by 25%.

CALCULATING MAXIMUM WATT DENSITY

Factors to be taken into consideration

- A. Type of controls
- B. Voltage variations
- C. Machine cycling rate
- D. Type of resin being processed
- E. Coefficient of thermal expansion and conductivity of the cylinder
- F. Designing a heater that closely matches the wattage requirement will decrease the frequency of cycling and temperature overshoot, thereby increasing the life of the heater.

Once these factors have been established, proceed with the following steps:

1. Determine the maximum operating temperature.
2. Calculate the total wattage required to obtain the maximum operating temperature. (See engineering section.)
3. Determine the quantity and size of the heater bands to be used. 1-1/2" through 3" wide band heaters have proven to be the most efficient and reliable in most cylindrical heating applications.
4. Determine individual band heater wattage by dividing the total required wattage by the quantity of band heaters selected.
5. Determine the band heater watt density by subtracting unheated areas from the band heater diameter created by screw terminals, gaps, holes, and cutouts (see formula below).
6. Determine if the required watt density previously calculated exceeds the maximum recommended watt density. Note the maximum cylinder temperature required on the left-hand side of the graph, follow the horizontal line until it intersects with the line of the band heater being used, and read directly down to obtain the maximum recommended watt density (W/in²).
7. If the calculated watt density is higher than the recommended value, it must be corrected or it will cause poor heater life. This can be accomplished by using more band heaters, lowering the heater wattage, or using a different construction type or a different type of band heater.
8. Should you have a problem in selecting the proper band heater or establishing watt density for your application, consult with one of the qualified engineers at Tempco.

Nominal Unheated Areas	
Construction Style	Unheated Area to Subtract
One-piece band	1" × width
Two-piece band	2" × width
Holes and cutouts	Size + 1/2" × width

Watt Density Formula

$$\text{Watt Density (W/in}^2\text{)} = \frac{\text{Wattage}}{(3.14 \times (\text{Band ID}) - \text{Gap} - 1 - 3/8) \times \text{Band Width} - \text{Unheated Area (see table)}}$$

Unheated Area (See Table) = Unheated area for construction style + unheated area for any holes or cutouts

Duraband® Construction Styles

3 CONSTRUCTION TYPES

One-Piece Band

The one-piece construction is available on any screw or lead termination and clamping variation. It can be used where band heaters can be slipped over the end of the cylinder.

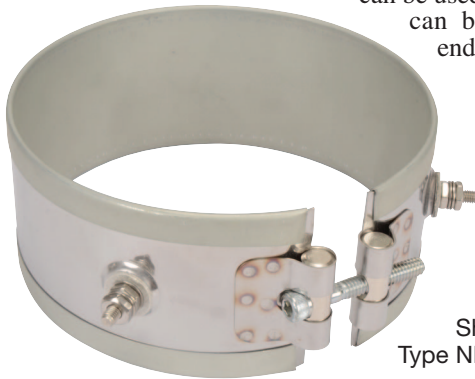

Shown with Type NB Built-In Strap

Two-Piece Band

The Two-Piece construction is available on any screw or lead and clamping variation. The Duraband two-piece design provides a **built-in hinge**, making handling and installation easier. It is used on large cylinders or where the heater cannot be slipped over the end of the cylinder. Two-piece band heaters are rated at watts and volts per each half when ordering.



Shown with Type NS Built-In Strap

NOTE: Multiple segment designs are recommended on larger diameter (typically larger than 15") heaters to improve the clamping force and

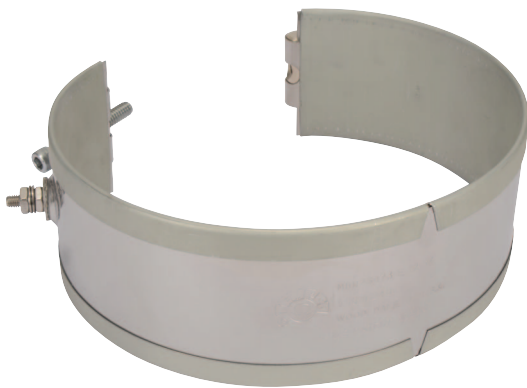

Shown with Type NE Built-In Strap

One-Piece Expandable Band

The one-piece expandable construction is available on any screw or lead and clamping variation. It can be used where a one-piece band heater would have to be expanded to fit over the barrel during installation, rather than slipped over the end of the barrel.



Note: The One-Piece Expandable Band should not be opened and closed more than twice.

Duraband® Construction/Clamping Variations

Standard Built-In Strap Clamping (Low Thermal Expansion)

The Built-In Strap is available with any screw or lead termination and construction variation. The Built-In Strap eliminates the use of awkward-to-handle separate straps, providing more drawing power than any other type of clamping system. The Duraband with Built-In Strap is standard on many designs.

Consult Tempco for multiple segment heaters.

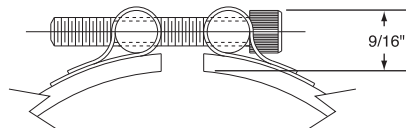

Type NB Shown

Type NB—One-Piece Band
Min. ID: 2" (50.8 mm)
Min. Width: 1-1/4" (31.8 mm)

Type NS—Two-Piece Band
Min. ID: 3" (76.2 mm)
Min. Width: 1-1/4" (31.8 mm)

Type NE—One-Piece Expandable Band
Min. ID: 2-1/2" (63.5 mm)
Min. Width: 1-1/4" (31.8 mm)

Duraband® Construction/Clamping Variations

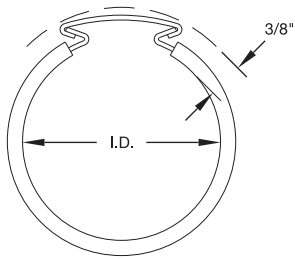

Wedge Lock

Wedge Lock clamping is designed for applications where mounting space is severely limited. It lends itself mainly to small diameter nozzle heaters.

Type TWL—One-Piece Band

- Min. ID:** 1" (25.4 mm)
- Min. Width:** 1" (25.4 mm)
- Max. Width:** 3-1/2" (88.9 mm)

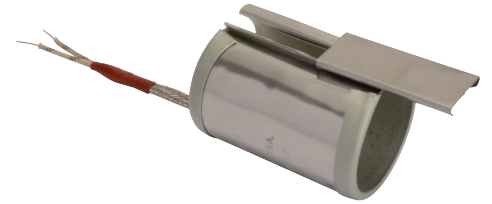

Separate Straps

The Separate Strap clamping is available with any screw or lead termination and construction variation. It is strongly recommended that the Duraband with Built-In Strap design be used whenever possible because it provides more drawing power than any other type of clamping system.

Consult Tempco for multiple segment heaters.



Type SB Shown

Type SB—One-Piece Band

- Min. ID:** 7/8" (22.2 mm)
- Min. Width:** 3/4" (19.1 mm)

Type SS—Two-Piece Band

- Min. ID:** 2" (50.8 mm)
- Min. Width:** 3/4" (19.1 mm)

Type SE—One-Piece Expandable Band

- Min. ID:** 2-1/2" (63.5 mm)
- Min. Width:** 1-1/4" (31.8 mm)

Clearance Dimensions for Separate Strap Clamping

Separate strap clearance dimensions are dependent on heater ID. The strap dimensions are shown below.

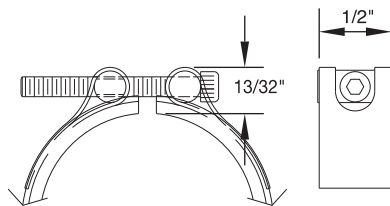

< 2" ID — 6-32 Screw

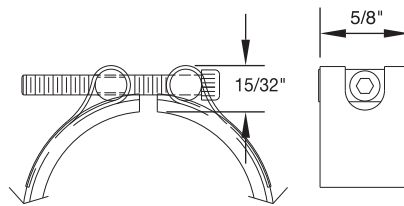

2 to 3-1/2" ID — 8-32 Screw

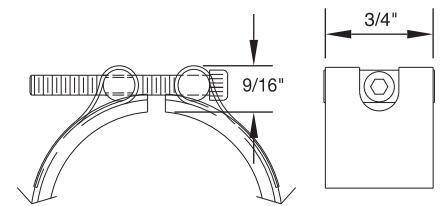

> 3-1/2" ID — 1/4-20 Screw



Spring Loaded with Built-In Bracket

The Heavy Duty Stainless Steel Spring with Built-In Bracket is a variation on the basic Duraband design. It is available with any screw or lead termination and construction variation. It is recommended for heaters over 12" in diameter, and for any diameter heater used in the vertical position, to prevent the heater from slipping off the machine. The springs provide constant tension, therefore maintaining optimum surface contact against the cylinder being heated.

Consult Tempco for multiple segment heaters.

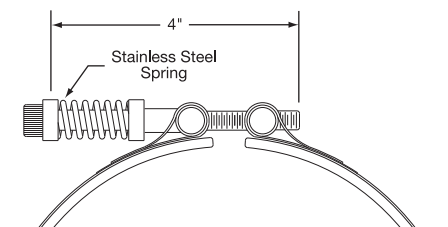

Type SL—One-Piece Band

- Min. ID:** 4" (101.6 mm)
- Min. Width:** 1-1/4" (31.8 mm)

Type NSL—Two-Piece Band

- Min. ID:** 4" (101.6 mm)
- Min. Width:** 1-1/4" (31.8 mm)

Type NEL—One-Piece Expandable Band

- Min. ID:** 4" (101.6 mm)
- Min. Width:** 1-1/4" (31.8 mm)

Duraband® Construction/Clamping Variations

Spring Loaded Quick Disconnect



This construction style is a hybrid between the Spring Loaded Clamp with Built-In Bracket and the Latch and Trunnion style clamping. Utilizing a built in bracket and heavy duty flanges, this clamping style is durable and easy to work with in the field. The spring provides relief for thermal expansion and provides strong clamping for the band. This clamping style is available with either lead or screw terminal type terminations.

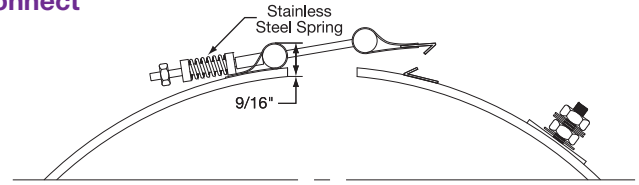

Consult Tempco for multiple segment heaters.

Type SLQD One-Piece Band

Min. ID: 3.5" (88.9 mm)
Min. Width: 1.25" (31.75 mm)

Type NSLQD Two-Piece Band

Min. ID: 4" (101.6 mm)
Min. Width: 1.25" (31.75 mm)

Type NELQD One-Piece Expandable Band

Min. ID: 3.5" (88.9 mm)
Min. Width: 1.25" (31.75 mm)



Latch and Trunnion

The Latch and Trunnion Clamping System is available with any screw or lead termination and construction variation. It is ideal in absorbing thermal expansion due to the spring loading on the screws. The latch fully opens, facilitating installation on large diameter cylinders. The outer sheath is made from a Low Thermal Expansion alloy.

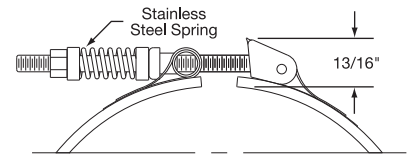

Consult Tempco for multiple segment heaters.

Type LT—One-Piece Band

Min. ID: 7" (177.8 mm)
Min. Width: 1-1/2" (38.1 mm)

Type LS—Two-Piece Band

Min. ID: 7" (177.8 mm)
Min. Width: 1-1/2" (38.1 mm)

Type LE—One-Piece Expandable Band

Min. ID: 7" (177.8 mm)
Min. Width: 1-1/2" (38.1 mm)

Bent-Up Flange (Ears)

The Bent-Up Flange clamping is available with any screw or lead termination and construction variation. The outer sheath is made from a Low Thermal Expansion alloy. The Bent-Up Flange design is best suited for narrow band heaters with small diameters.

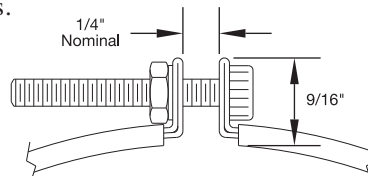

Note: The Bent-Up flange design should only be used when other clamping methods are not suitable for a specific application. Tempco recommends Built-In Strap Clamping be used whenever possible, especially on large diameter heaters, because it provides superior clamping power.



Type FB—One-Piece Band

Min. ID: 1" (25.4 mm)
Min. Width: 3/4" (19.1 mm)

Type FS—Two-Piece Band

Min. ID: 2" (50.8 mm)
Min. Width: 3/4" (19.1 mm)

Type FE—One-Piece Expandable Band

Min. ID: 2-1/2" (63.5 mm)
Min. Width: 1-1/4" (31.8 mm)

Duraband® Internal Reverse Bands

Type RN□—Internal Reverse Band (with bracket clamping)

This construction style is used to heat cylindrical surfaces from the inside on heaters 5-1/2" diameter and larger.

Type RNB—Reverse 1-Piece Construction

ID: 5-1/2" (139.7 mm) to 10" (254.0 mm)
Width: 1" (25.4 mm) to 3-1/2" (88.9 mm)
Maximum Voltage: 240VAC

Type RNS—Reverse 2-Piece Construction

ID: 10" (254.0 mm) to 20" (508.0 mm)
Width: 1" (25.4 mm) to 3-1/2" (88.9 mm)
Maximum Voltage: 240VAC

For IDs greater than 20", consult Tempco with your requirements.



Type RTWL— Internal Reverse Band (with wedge lock clamping)

This construction style is used to heat cylindrical surfaces from the inside on heaters less than 5" outside diameter.

ID: Less than 5-1/2" (139.7 mm)
Width: 1" to 3-1/2" (25.4 - 88.9 mm)

Duraband Partial Coverage

Type NS — 2-Piece With Built-In Brackets

Partial coverage band heaters are normally required when holes and cutouts will not allow the heater to sufficiently clear the machine obstructions. The preferred method of construction is the Two-Piece Band Heater with Built-In Brackets as illustrated. The heater is screwed down to the cylinder at the ends and the built-in Low Thermal Expansion Strap pulls the heater tightly against the cylinder being heated. The standard center of hole to edge of heater dimension is 1/4". When ordering, please provide the angle of coverage from center to center of the mounting screw holes as shown.

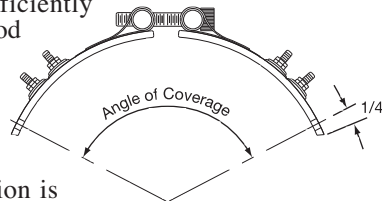

Type PS — One-Piece with Two-Piece Separate Strap with Padded Ends

The alternate method of partial coverage construction is the One-Piece Band Heater with a separate Two-Piece Strap. The two-piece strap itself is screwed down at the padded ends, allowing the heater to float between the pads as illustrated. When the strap is tightened, it will pull the heater against the cylinder being heated. The standard center of hole to edge of heater dimension is 1/4". When ordering, please provide the angle of coverage from center to center of the mounting screw holes as shown.

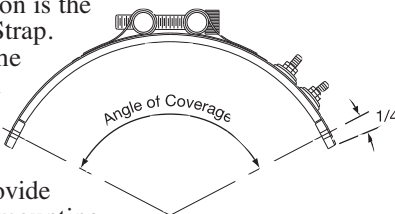

Type NB — One-Piece with Built-In Strap Clamping

Another alternate method of partial coverage construction. The one piece with clamp screws on both sides allows it to be secured to anchor points on either side of a barrel without drilling holes into the barrel.

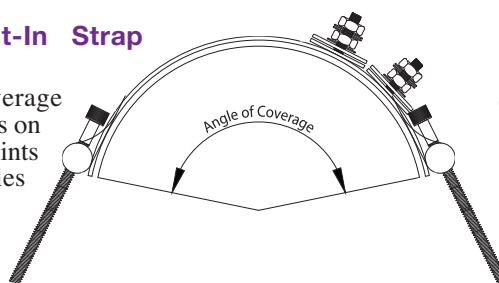

Terminations

Stainless Steel Power Terminals: Type T1, Type T2 & Type T3

Available on any clamping or construction variation, the specially designed Stainless Steel Power Terminals are internally connected to the heater and are resistant to over-torquing. The screw terminals are virtually unbreakable. Secure tightening of the electrical connections is essential for safety and long heater life.

Duraband® Type T1 – Screw Terminals

Considered standard on most band heaters unless otherwise specified.

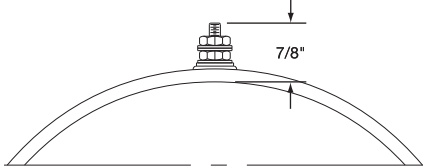

One-Piece Band

Standard Termination Location:
each side of gap; center of width

- * **Minimum Inside Diameter:** 2" (50.8 mm)
- * **Minimum Width:** 7/8" (22.2 mm)
- * **Post Terminals:** 10-32 standard except 8-32 on < 1" wide heaters & heaters with ID < 3"
- * **Max. Volts/Amps:** 480VAC/ 25A (10-32) or 20A (8-32)

Two-Piece Band

Standard Termination Location:
next to gaps on each half;
center of width

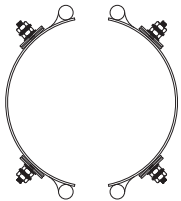

- * **Minimum Inside Diameter:** 2" (50.8 mm)
- * **Minimum Width:** 7/8" (22.2 mm)
- * **Post Terminals:** 10-32 standard except 8-32 on < 1" wide heaters & heaters with ID < 3"
- * **Max. Volts/Amps:** 480VAC/ 25A (10-32) or 20A (8-32) each half

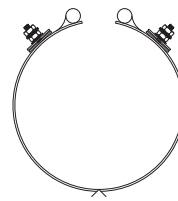

One-Piece Expandable Band

Standard Termination Location:
each side of gap; center of width

- * **Minimum Inside Diameter:** 2-1/2" (63.5 mm)
- * **Minimum Width:** 1-1/4" (31.8 mm)
- * **Post Terminals:** 10-32 standard except 8-32 on heaters with ID < 3"
- * **Max. Volts/Amps:** 480VAC/ 25A (10-32) or 20A (8-32)

Duraband Type T2 – Screw Terminals

Recommended for narrow band heaters where screw terminals are preferred or the C2 terminal box protection is required.

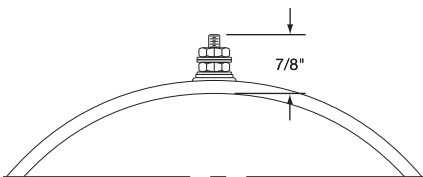

One-Piece Band

Standard Termination Location:
next to gap; center of width

- * **Minimum Inside Diameter:** 2" (50.8 mm)
- * **Minimum Width:** 7/8" (22.2 mm)
- * **Post Terminals:** 10-32 standard except 8-32 on < 1" wide heaters & heaters with ID < 3"
- * **Max. Volts/Amps:** 480VAC/ 25A (10-32) or 20A (8-32)

Two-Piece Band

Standard Termination Location:
next to same gap on each half;
center of width

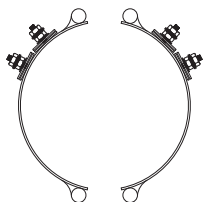

- * **Minimum Inside Diameter:** 2" (50.8 mm)
- * **Minimum Width:** 7/8" (22.2 mm)
- * **Post Terminals:** 10-32 standard except 8-32 on < 1" wide heaters & heaters with ID < 3"
- * **Max. Volts/Amps:** 480VAC/ 25A (10-32) or 20A (8-32) each half

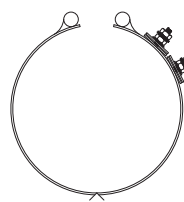

One-Piece Expandable Band

Standard Termination Location:
next to gap; center of width

- * **Minimum Inside Diameter:** 2-1/2" (63.5 mm)
- * **Minimum Width:** 1-1/4" (31.8 mm)
- * **Post Terminals:** 10-32 standard except 8-32 on heaters with ID < 3"
- * **Max. Volts/Amps:** 480VAC/ 25A (10-32) or 20A (8-32)

Duraband® Type T3 – Screw Terminals

The preferred design on band heaters over 3" (76.2 mm) wide or when C3 terminal box is required.

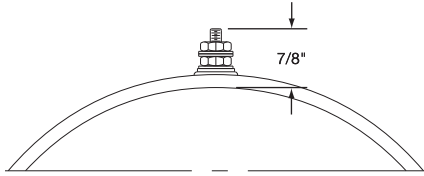

One-Piece Band

Standard Termination Location:
next to gap; across center of width

- * **Minimum Inside Diameter:** 2" (50.8 mm)
- * **Minimum Width:** 2" (50.8 mm)
- * **Post Terminals:** 10-32 standard except 8-32 on 2" to 2-1/2" wide heaters & heaters with ID < 3"
- * **Max. Volts/Amps:** 480VAC/25A (10-32) or 20A (8-32)

Two-Piece Band

Standard Termination Location:
next to same gap on each half;
across center of width

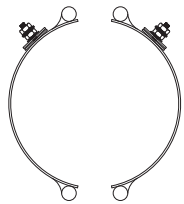

- * **Minimum Inside Diameter:**
2" (50.8 mm)
- * **Minimum Width:** 2" (50.8 mm)
- * **Post Terminals:** 10-32 standard except 8-32 on 2" to 2-1/2" wide heaters & heaters with ID < 3"
- * **Max. Volts/Amps:** 480VAC/
25A (10-32) or 20A (8-32) each half

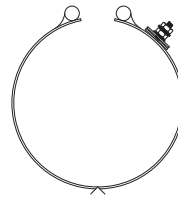

One-Piece Expandable Band

Standard Termination Location:
next to gap; across center of width

- * **Minimum Inside Diameter:**
2-1/2" (63.5 mm)
- * **Minimum Width:** 2" (50.8 mm)
- * **Post Terminals:** 10-32 standard except 8-32 on 2" to 2-1/2" wide heaters & heaters with ID < 3"
- * **Max. Volts/Amps:** 480VAC/
25A (10-32) or 20A (8-32)

Optional Igloo™ Ceramic Covers for Heaters with Screw Terminals

Igloo™ Ceramic Terminal Covers consist of two individual ceramic parts. Unlike conventional ceramic caps, Igloo fully insulates any standard #8 or #10 terminal lugs used for electrical hook-ups.

Limitations

To assemble Igloo covers, terminals should be at least 7/8" apart.

Min. ID: 2" (50.8 mm) **Min. Width:** 1-1/4" (31.7 mm)

Three types of Igloo™ bases are available:

- Type C6** – Double Port In-Line P/N CER-101-104
- Type C7** – Double Port 90° P/N CER-101-106
- Type C8** – Single Port P/N CER-101-107

Igloo™ caps are available in the following three screw terminal sizes:

- 10-32** – P/N CER-102-101
- 10-24** – P/N CER-102-104
- 8-32** – P/N CER-102-105

When ordering, specify the type of Igloo and the screw terminal size.

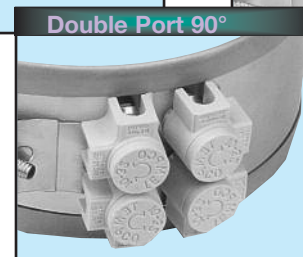
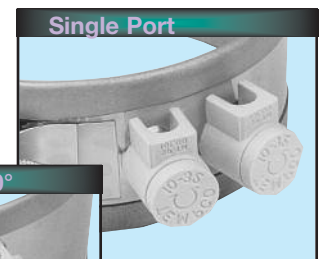
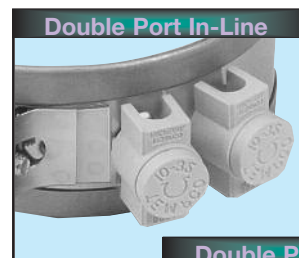
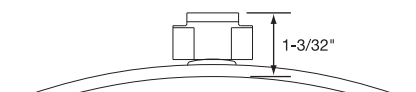

Exposed electrical wiring on band heater installations is a violation of Electrical Safety Codes including O.S.H.A.

Terminations

Low-Profile Button Terminals: Type B1, Type B2 & Type B3

Available on any clamping or construction variation, the specially designed Stainless Steel Button Terminals are internally connected to the heater and are resistant to over-torquing

while offering a low profile for tight spaces. They are virtually unbreakable. Secure tightening of the electrical connections is essential for safety and long heater life.

Duraband® Type B1 – Button Terminals

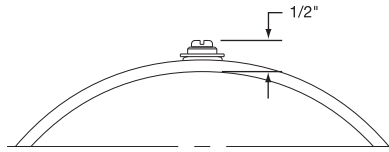

One-Piece Band

Standard Termination Location:
each side of gap; center of width

- * **Minimum Inside Diameter:** 2" (50.8 mm)
- * **Minimum Width:** 1-1/2" (38.1 mm)
- * **Screw Size:** 10-32 standard except 6-32 on IDs < 5"
- * **Maximum Volts:** 480VAC
- * **Maximum Amps:** 25A (10-32) or 20A (6-32)

Two-Piece Band

Standard Termination Location:
next to gaps on each half;
center of width

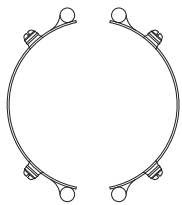

- * **Minimum Inside Diameter:** 2" (50.8 mm)
- * **Minimum Width:** 1-1/2" (38.1 mm)
- * **Screw Size:** 10-32 standard except 6-32 on IDs < 5"
- * **Maximum Volts/Amps:** 480VAC/ 25A (10-32) or 20A (6-32) each half

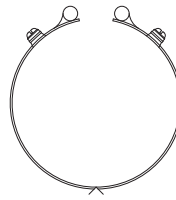

One-Piece Expandable Band

Standard Termination Location:
each side of gap; center of width

- * **Minimum Inside Diameter:** 2-1/2" (63.5 mm)
- * **Minimum Width:** 1-1/2" (38.1 mm)
- * **Screw Size:** 10-32 standard except 6-32 on IDs < 5"
- * **Maximum Volts/Amps:** 480VAC/ 25A (10-32) or 20A (6-32)

Duraband Type B2 – Button Terminals

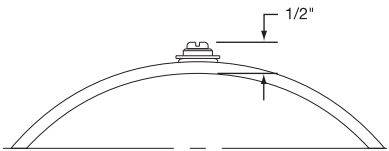

One-Piece Band

Standard Termination Location:
next to gap; center of width

- * **Minimum Inside Diameter:** 2" (50.8 mm)
- * **Minimum Width:** 1-1/2" (38.1 mm)
- * **Screw Size:** 10-32 standard except 6-32 on IDs < 5"
- * **Maximum Volts:** 480VAC
- * **Maximum Amps:** 25A (10-32) or 20A (6-32)

Two-Piece Band

Standard Termination Location:
next to same gap on each half;
center of width

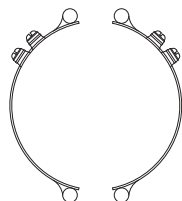

- * **Minimum Inside Diameter:** 2" (50.8 mm)
- * **Minimum Width:** 1-1/2" (38.1 mm)
- * **Screw Size:** 10-32 standard except 6-32 on IDs < 5"
- * **Maximum Volts/Amps:** 480VAC/ 25A (10-32) or 20A (6-32) each half

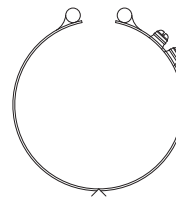

One-Piece Expandable Band

Standard Termination Location:
next to gap; center of width

- * **Minimum Inside Diameter:** 2-1/2" (63.5 mm)
- * **Minimum Width:** 1-1/2" (38.1 mm)
- * **Screw Size:** 10-32 standard except 6-32 on IDs < 5"
- * **Maximum Volts/Amps:** 480VAC/ 25A (10-32) or 20A (6-32)

View Product Inventory @ www.tempco.com

Duraband® Type B3 – Button Terminals

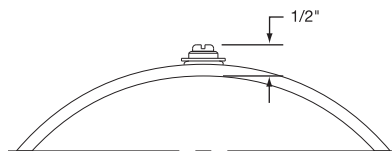

One-Piece Band

Standard Termination Location:
next to gap; across center of width

- * **Minimum Inside Diameter:** 2" (50.8 mm)
- * **Minimum Width:** 2-3/8" (60.3 mm)
- * **Screw Size:**
10-32 standard except 6-32 on IDs < 5"
- * **Maximum Volts:** 480VAC
- * **Maximum Amps:** 25A (10-32) or 20A (6-32)

Two-Piece Band

Standard Termination Location:
next to same gap on each half;
across center of width

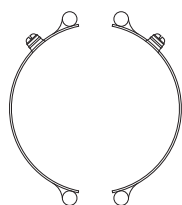

- * **Minimum Inside Diameter:**
2" (50.8 mm)
- * **Minimum Width:** 2-3/8" (60.3 mm)
- * **Screw Size:** 10-32 standard except
6-32 on IDs < 5"
- * **Maximum Volts/Amps:** 480VAC/
25A (10-32) or 20A (6-32) each half

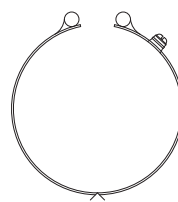

One-Piece Expandable Band

Standard Termination Location:
next to gap; across center of width

- * **Minimum Inside Diameter:**
2-1/2" (63.5 mm)
- * **Minimum Width:** 2-3/8" (60.3 mm)
- * **Screw Size:** 10-32 standard except
6-32 on IDs < 5"
- * **Maximum Volts/Amps:** 480VAC/
25A (10-32) or 20A (6-32)

Plain Lead Wire Terminations: Type L1, Type L2 & Type L4

Available on any clamping or construction variation.

Duraband Type L1 – Straight Lead Wires



The lead wires exit through a brass eyelet. The standard flexible leads are 10" long with 3" of fiberglass sleeving.

If longer leads are required, specify when ordering.



One-Piece Band

Standard Termination Location:
next to gap; center of width

- * **Minimum Inside Diameter:** 2" (50.8 mm)
- * **Minimum Width:** 1" (25.4 mm)
- * **Maximum Volts:** 480VAC
- * **Maximum Amps:** 10A

Two-Piece Band

Standard Termination Location:
next to same gap on each half;
center of width

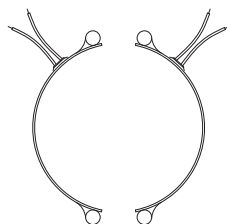

- * **Minimum Inside Diameter:**
2" (50.8 mm)
- * **Minimum Width:** 1" (25.4 mm)
- * **Maximum Volts:** 480V each half
- * **Maximum Amps:** 10A each half

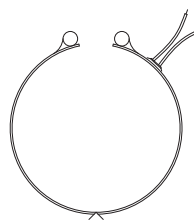

One-Piece Expandable Band

Standard Termination Location:
next to gap; center of width

- * **Minimum Inside Diameter:**
2-1/2" (63.5 mm)
- * **Minimum Width:** 1-1/4" (31.8 mm)
- * **Maximum Volts:** 480V
- * **Maximum Amps:** 10A



Terminations

Duraband® Type L2 – Lead Wires

Continued from previous page...

L2 is the preferred termination on all small diameter and small width band heaters. The standard flexible leads are 10" long with 3" of fiberglass sleeving.

If longer leads are required, specify when ordering.



One-Piece Band

Standard Termination Location:
each side of gap; edge of width

- * **Minimum Inside Diameter:** 7/8" (22.2 mm)
- * **Minimum Width:** 3/4" (19.1 mm)
- * **Maximum Volts:** 480VAC
- * **Maximum Amps:** 10A

Two-Piece Band

Standard Termination Location:
each side of each gap;
edge of width

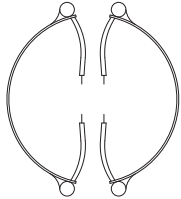

- * **Minimum Inside Diameter:**
2" (50.8 mm)
- * **Minimum Width:** 3/4" (19.1 mm)
- * **Maximum Volts:** 480V each half
- * **Maximum Amps:** 10A each half

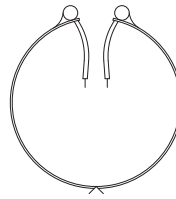

One-Piece Expandable Band

Standard Termination Location:
each side of gap;
edge of width

- * **Minimum Inside Diameter:**
2-1/2" (63.5 mm)
- * **Minimum Width:** 1-1/4" (31.8 mm)
- * **Maximum Volts:** 480V
- * **Maximum Amps:** 10A

Duraband Type L4 – Lead Wires

L4 is a suitable lead termination for small band heaters. The standard flexible leads are 10" long with 3" of fiberglass sleeving.

If longer leads are required, specify when ordering.



One-Piece Band

Standard Termination Location:
same side of gap; edge of width

- * **Minimum Inside Diameter:** 7/8" (22.2 mm)
- * **Minimum Width:** 1" (25.4 mm)
- * **Maximum Volts:** 480VAC
- * **Maximum Amps:** 10A

Two-Piece Band

Standard Termination Location:
each side of same gap;
center of width

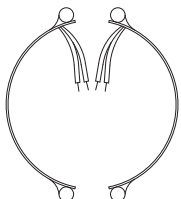

- * **Minimum Inside Diameter:**
2" (50.8 mm)
- * **Minimum Width:** 1" (25.4 mm)
- * **Maximum Volts:** 480V each half
- * **Maximum Amps:** 10A each half

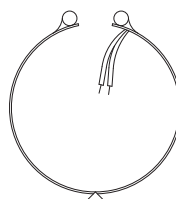

One-Piece Expandable Band

Standard Termination Location:
same side of gap; edge of width

- * **Minimum Inside Diameter:**
2-1/2" (63.5 mm)
- * **Minimum Width:** 1-1/4" (31.8 mm)
- * **Maximum Volts:** 480VAC
- * **Maximum Amps:** 10A

Abrasion Resistant Lead Terminations:

Type W1, Type W2, Type W2M, Type W3, Type W4 & Type W5M

Available on any clamping or construction variation.
Wire braid leads offer sharp bending not possible with armor cable.

Duraband® Type W1 & W1T – Straight Wire Braid Leads



Type W1



Type W1T

Type W1 – Braided lead wire crimped in place for heaters under 2-1/2" I.D. and/or under 1-1/4" width.

Type W1T – Braided lead wire attached with a threaded fitting for heaters over/equal 2-1/2" I.D. and over/equal 1-1/4" width.

One-Piece Band

Standard Termination Location:
next to gap; center of width

- * Minimum Inside Diameter: 2" (50.8 mm)
- * Minimum Width: 1" (25.4 mm)
- * Maximum Volts: 480VAC
- * Maximum Amps: 10A

The standard leads are 10" of wire braid over 12" of flexible leads.

If longer leads are required, specify when ordering.

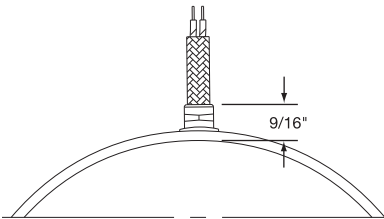

Two-Piece Band

Standard Termination Location:
next to same gap on each half;
center of width

- * Minimum Inside Diameter: 2" (50.8 mm)
- * Minimum Width: 1" (25.4 mm)
- * Maximum Volts: 480VAC each half
- * Maximum Amps: 10A each half

One-Piece Expandable Band

Standard Termination Location:
next to gap; center of width

- * Minimum Inside Diameter: 2-1/2" (63.5 mm)
- * Minimum Width: 1-1/4" (31.8 mm)
- * Maximum Volts: 480VAC
- * Maximum Amps: 10A

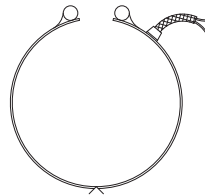

Duraband Type W2 – Wire Braid Leads

The W2 wire braid exits at 180° from the gap for special nozzle heating applications. Sleeving is used for additional protection. The standard leads are 10" of wire braid over 12" of flexible leads with 3" of fiber-glass sleeving.

If longer leads are required, specify when ordering.



Note: Type W2 is not available on Two-Piece or One-Piece Expandable Duraband Heaters

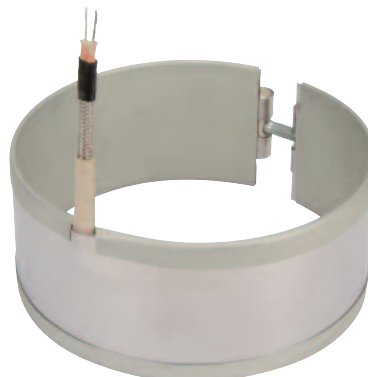

One-Piece Band

Standard Termination Location:
opposite the gap; edge of width

- * Minimum Inside Diameter: 7/8" (22.2 mm)
- * Minimum Width: 1-1/8" (28.6 mm)
- * Maximum Volts: 480VAC
- * Maximum Amps: 10A

CONTINUED

Terminations

Duraband® Type W3 – Single Wire Braid Leads

Continued from previous page...

Highly recommended for nozzle heating applications. The standard leads are 10" of wire braid over 12" of flexible leads with 3" of fiberglass sleeving.

If longer leads are required, specify when ordering.

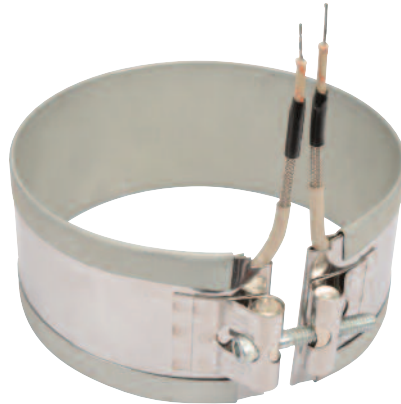

One-Piece Band

Standard Termination Location:
each side of gap; edge of width

- * **Minimum Inside Diameter:**
3/4" (19.1 mm)
- * **Minimum Width:** 7/8" (22.2 mm)
- * **Maximum Volts:** 480VAC
- * **Maximum Amps:** 10A

Two-Piece Band

Standard Termination Location:
each side of each gap; edge of width

- * **Minimum Inside Diameter:**
2" (50.8 mm)
- * **Minimum Width:** 3/4" (19.1 mm)
- * **Maximum Volts:** 480VAC each half
- * **Maximum Amps:** 10A each half

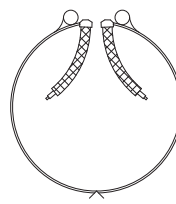
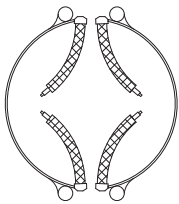

One-Piece Expandable Band

Standard Termination Location:
each side of gap; edge of width

- * **Minimum Inside Diameter:**
2-1/2" (63.5 mm)
- * **Minimum Width:** 1-1/4" (31.8 mm)
- * **Maximum Volts:** 480VAC
- * **Maximum Amps:** 10A

Duraband Type W4 – Wire Braid Leads On One Side

A suitable termination for nozzle heating applications. The standard leads are 10" of wire braid over 12" of flexible leads.

If longer leads are required, specify when ordering.

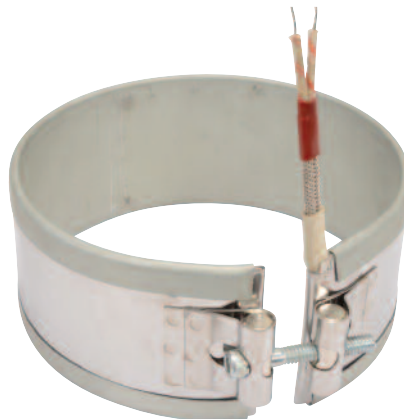

One-Piece Band

Standard Termination Location:
next to gap; edge of width

- * **Minimum Inside Diameter:**
7/8" (22.2 mm)
- * **Minimum Width:** 1" (25.4 mm)
- * **Maximum Volts:** 480VAC
- * **Maximum Amps:** 10A

Two-Piece Band

Standard Termination Location:
next to same gap on each half;
edge of width

- * **Minimum Inside Diameter:**
2" (50.8 mm)
- * **Minimum Width:** 1" (25.4 mm)
- * **Maximum Volts:** 480VAC each half
- * **Maximum Amps:** 10A each half

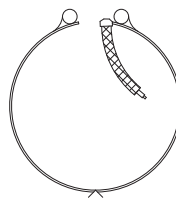
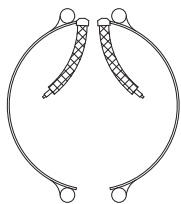

One-Piece Expandable Band

Standard Termination Location:
next to gap; edge of width

- * **Minimum Inside Diameter:**
2-1/2" (63.5 mm)
- * **Minimum Width:** 1-1/4" (31.8 mm)
- * **Maximum Volts:** 480VAC
- * **Maximum Amps:** 10A

Duraband® Type W2M – Right-Angle Wire Braid Leads, 90° to Heater

Stainless Steel Wire Braid exits perpendicular to the heater centerline through a low profile stainless steel cap. This cap acts as a strain relief which protects against excessive flexing or pulling of the lead wire. The standard leads are 10" of wire braid over 12" of flexible leads.

If longer leads are required, specify when ordering.



Note: Stainless steel construction may be required for widths of 7/8" (22.2 mm) to 1-5/8" (41.3 mm).

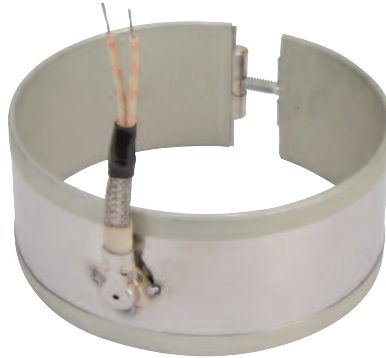

One-Piece Band

Standard Termination Location:
opposite of gap; center of width

- * **Minimum Inside Diameter:**
1-1/2" (38.1 mm)
- * **Minimum Width:** 1-1/4" (31.8 mm)
- * **Maximum Volts:** 480VAC
- * **Maximum Amps:** 10A

Two-Piece Band

Standard Termination Location:
next to same gap on each half;
center of width

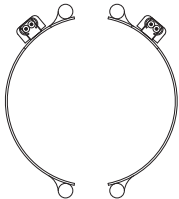

- * **Minimum Inside Diameter:**
2" (50.8 mm)
- * **Minimum Width:** 1-1/4" (31.8 mm)
- * **Maximum Volts:** 480VAC each half
- * **Maximum Amps:** 10A each half

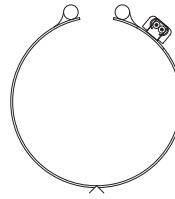

One-Piece Expandable Band

Standard Termination Location:
next to gap; center of width

- * **Minimum Inside Diameter:**
2-1/2" (63.5 mm)
- * **Minimum Width:** 1-1/4" (31.8 mm)
- * **Maximum Volts:** 480VAC
- * **Maximum Amps:** 10A

Duraband Type W5M – Right-Angle Wire Braid Leads, Parallel to Heater

Stainless Steel Wire Braid exits parallel to the heater centerline through a low profile stainless steel cap. This cap acts as a strain relief which protects against excessive flexing or pulling of the lead wire. The standard leads are 10" of wire braid over 12" of flexible leads.

If longer leads are required, specify when ordering.



Note: Stainless steel construction may be required for widths of 7/8" (22.2 mm) to 1-5/8" (41.3 mm).



One-Piece Band

Standard Termination Location:
opposite of gap; center of width

- * **Minimum Inside Diameter:**
1-1/2" (38.1 mm)
- * **Minimum Width:** 1-1/4" (31.8 mm)
- * **Maximum Volts:** 480VAC
- * **Maximum Amps:** 10A

Two-Piece Band

Standard Termination Location:
next to same gap on each side;
center of width

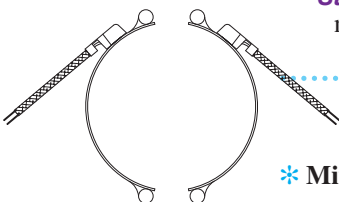

- * **Minimum Inside Diameter:**
2" (50.8 mm)
- * **Minimum Width:** 1-1/4" (31.8 mm)
- * **Maximum Volts:** 480VAC each half
- * **Maximum Amps:** 10A each half

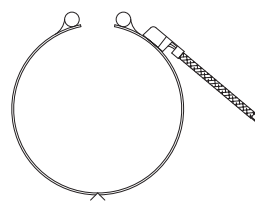

One-Piece Expandable Band

Standard Termination Location:
next to gap; center of width

- * **Minimum Inside Diameter:**
2-1/2" (63.5 mm)
- * **Minimum Width:** 1-1/4" (31.8 mm)
- * **Maximum Volts:** 480VAC
- * **Maximum Amps:** 10A



Terminations

Duraband® Cable Terminations: Type R1, Type R2 & Type R3

Available on any clamping or construction variation. Armor cable provides far superior protection to lead wires where abrasion is a constant problem. The standard leads are 10" of armor cable over 12" of flexible leads.

If longer leads are required, specify when ordering.

Duraband® Type R1 – Straight Armor Cable

Type R1A – Galvanized armor cable crimped in place for heaters under 2-1/2" I.D. and/or under 1-1/4" width.

Type R1AT – Galvanized armor cable attached with a threaded fitting for heaters over/equal 2-1/2" I.D. and over/equal 1-1/4" width.

Type R1B – Stainless Steel armor cable crimped in place for heaters under 2-1/2" I.D. and/or under 1-1/4" width.

Type R1BT – Stainless Steel armor cable attached with a threaded fitting for heaters over/equal 2-1/2" I.D. and over/equal 1-1/4" width.

Type R1C – Galvanized armor cable, tack welded

Type R1D – SS armor cable, tack welded

Type R1E – Galvanized armor cable, full silver brazing

Type R1F – SS armor cable, full silver brazing

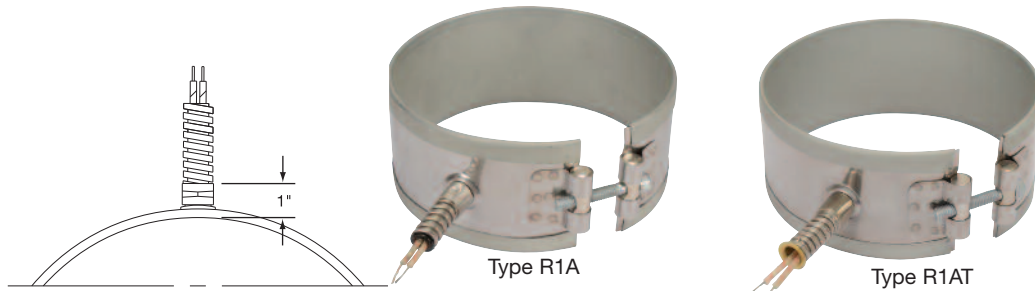

One-Piece Band

Standard Termination Location:
next to gap; center of width

- * **Minimum Inside Diameter:** 1-1/2" (38.1 mm)
- * **Minimum Width:** 1" (25.4 mm)
- * **Maximum Volts:** 480VAC
- * **Maximum Amps:** 10A

Two-Piece Band

Standard Termination Location:
next to same gap on each half;
center of width

- * **Minimum Inside Diameter:** 2" (50.8 mm)
- * **Minimum Width:** 1" (25.4 mm)
- * **Maximum Volts/Amps:** 480VAC/10A each half

One-Piece Expandable Band

Standard Termination Location:
next to gap; center of width

- * **Minimum Inside Diameter:** 2-1/2" (65.3 mm)
- * **Minimum Width:** 1-1/4" (31.8 mm)
- * **Maximum Volts/Amps:** 480VAC/10A

Duraband Type R2 – Right-Angle Armor Cable

Type R2A – Galvanized armor cable, crimped

Type R2B – SS armor cable, crimped

Type R2C – Plain leads, no cable

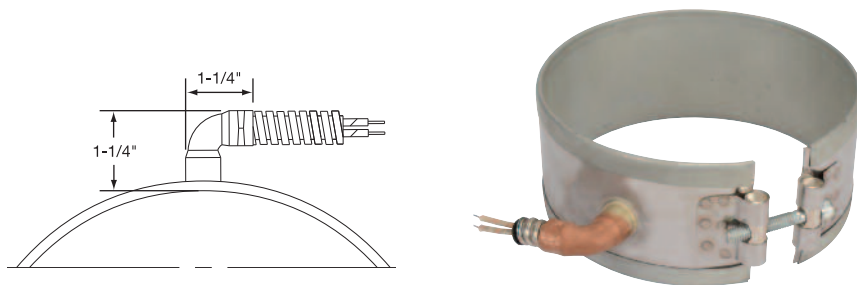

One-Piece Band

Standard Termination Location:
next to gap; center of width

- * **Minimum Inside Diameter:** 1-1/2" (38.1 mm)
- * **Minimum Width:** 1-1/4" (31.8 mm)
- * **Maximum Volts:** 480VAC
- * **Maximum Amps:** 10A

Two-Piece Band

Standard Termination Location:
next to same gap on each half;
center of width

- * **Minimum Inside Diameter:** 2" (50.8 mm)
- * **Minimum Width:** 1-1/4" (31.8 mm)
- * **Maximum Volts/Amps:** 480VAC/10A each half

One-Piece Expandable Band

Standard Termination Location:
next to gap; center of width

- * **Minimum Inside Diameter:** 2-1/2" (63.5 mm)
- * **Minimum Width:** 1-1/4" (31.8 mm)
- * **Maximum Volts/Amps:** 480VAC/10A

Duraband® Type R3 – Removable Armor Cable

Type R3A – Plain Leads & Female Fitting

Type R3B – Leads, Male Adapter & Galvanized Armor

Type R3C – Leads, Male Adapter & SS Armor

Recommended on applications where removable armor is required. The fitting will accept the standard armor cable connector. The standard leads are 10" of armor cable over 12" of flexible leads.

If longer leads are required, specify when ordering.

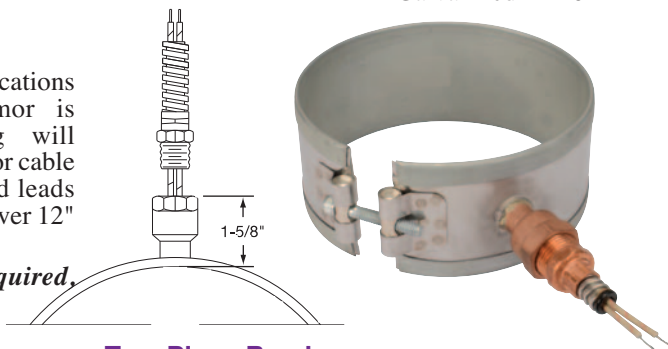

Two-Piece Band

Standard Termination Location: next to same gap on each half; center of width

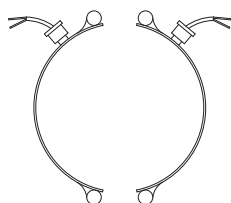

- * **Minimum Inside Diameter:** 2" (50.8 mm)
- * **Minimum Width:** 1-1/4" (31.7 mm)
- * **Maximum Volts/Amps:** 480VAC/10A each half

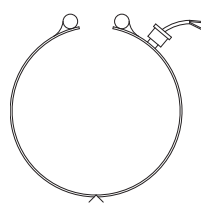

One-Piece Band

Standard Termination Location: next to gap; center of width

- * **Minimum Inside Diameter:** 1-1/2" (38.1 mm)
- * **Minimum Width:** 1-1/4" (31.7 mm)
- * **Maximum Volts/Amps:** 480VAC/10A

One-Piece Expandable Band

Standard Termination Location: next to gap; center of width

- * **Minimum Inside Diameter:** 2-1/2" (63.5 mm)
- * **Minimum Width:** 1-1/4" (31.8 mm)
- * **Maximum Volts/Amps:** 480VAC/10A

Duraband Type S1 – Lead Wire Spring Strain Relief

A strain relief spring is attached to the heater at the termination exit to reduce strain on leads subjected to excessive flexing. The spring is 2-1/8" long. The flexible standard leads are 10" long with 3" of fiberglass sleeving. *If longer leads are required, specify when ordering.*

Type S1A – Plain Leads and Strain Relief Spring crimped in place for heaters under 2-1/2" I.D. and/or under 1-1/4" width.

Type S1AT – Plain Leads and Strain Relief Spring attached with a threaded fitting for heaters over/equal 2-1/2" I.D. and over/equal 1-1/4" width.

Type S1B – Stainless Steel Wire Braided Leads and Strain Relief Spring crimped in place for heaters under 2-1/2" I.D. and/or under 1-1/4" width. 10" of braid over 12" of flexible leads is standard.

Type S1BT – Stainless Steel Wire Braided Leads and Strain Relief Spring attached with a threaded fitting for heaters over/equal 2-1/2" I.D. and over/equal 1-1/4" width. 10" of braid over 12" of flexible leads is standard.

One-Piece Band

Standard Termination Location: next to gap; center of width

- * **Minimum Inside Diameter:** 2" (50.8 mm)
- * **Minimum Width:** 1-1/4" (31.8 mm)
- * **Maximum Volts:** 480VAC
- * **Maximum Amps:** 10A

Two-Piece Band

Standard Termination Location: next to same gap on each half; center of width

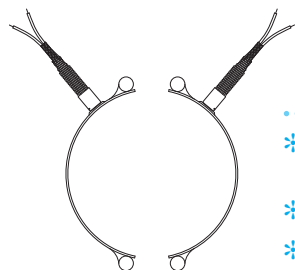

- * **Minimum Inside Diameter:** 2" (50.8 mm)
- * **Minimum Width:** 1-1/4" (31.75 mm)
- * **Maximum Volts/Amps:** 480VAC/10A each half

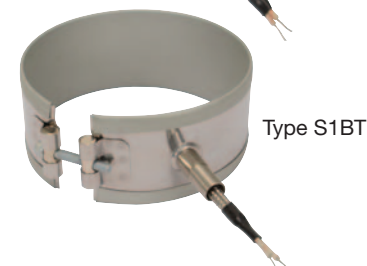
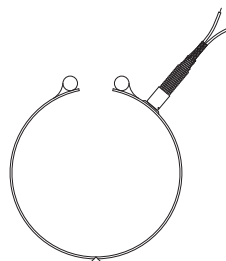

One-Piece Expandable Band

Standard Termination Location: next to gap; center of width

- * **Minimum Inside Diameter:** 2-1/2" (63.5 mm)
- * **Minimum Width:** 1-1/4" (31.75 mm)
- * **Maximum Volts/Amps:** 480VAC/10A

Terminations

General Purpose Terminal Boxes: Type C2 and Type C5

Available with any construction or clamping variation. They are a simple & economical way to protect employees from electric shock or prevent electric shorts that can result from exposed wiring on band heater electrical installations.

The Heavy Duty Terminal Boxes have 1/2" knockouts that will accept standard armor cable connectors. They can be field assembled on band heaters that have a center distance between terminal

screws of 7/8". Boxes can be pre-wired with galvanized armor, stainless steel armor, wire braid or plain leads. If a Low Profile Box with cable or leads is required, it is strongly recommended to order it pre-wired by the factory.

The standard leads are 10" of cable or wire braid over 12" of flexible leads. *If longer leads are required, specify when ordering.*

Duraband® Type C2 – Standard Terminal Boxes



One-Piece Band

Standard Termination Location:
next to gap; center of width

- * **Minimum Inside Diameter:** 2-1/2" (63.5 mm)
- * **Minimum Width:** 1" (25.4 mm) Heater widths between 1" and 2-1/2" require a minimum ID of 5-1/2" or greater.
- * **Maximum Volts/Amps:** 480VAC/25A

Type C2 □ – Standard Box

- C2A** – Box only
- C2B** – w/galvanized armor
- C2C** – w/stainless steel armor
- C2D** – w/wire braid

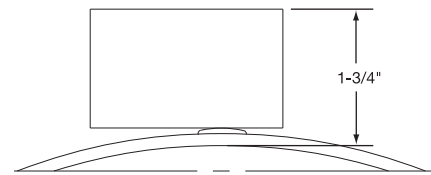

Two-Piece Band

Standard Termination Location:

next to same gap on each half; center of width

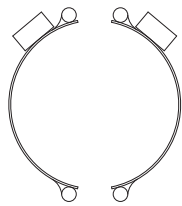

- * **Minimum Inside Diameter:** 3" (76.2 mm)
- * **Minimum Width:** 1" (25.4 mm) Heater widths between 1" and 2-1/2" require a minimum ID of 5-1/2" or greater.
- * **Max. Volts/Amps:** 480VAC/25A each half

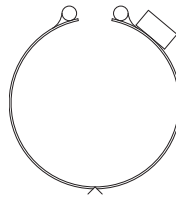

One-Piece Expandable Band

Standard Termination Location:
next to gap; center of width

- * **Minimum Inside Diameter:** 2-1/2" (63.5 mm)
- * **Minimum Width:** 1" (25.4 mm) Heater widths between 1" and 2-1/2" require a minimum ID of 5-1/2" or greater.
- * **Maximum Volts/Amps:** 480VAC/25A

Duraband Type C5 – Low Profile Terminal Boxes



One-Piece Band

Standard Termination Location:
next to gap; center of width

- * **Minimum Inside Diameter:** 2-1/2" (63.5 mm)
- * **Minimum Width:** 1" (25.4 mm) Heater widths between 1" and 2-1/2" require a minimum ID of 5-1/2" or greater.
- * **Maximum Volts/Amps:** 480VAC/25A

Type C5 □ – Low Profile Box

- C5A** – box only
- C5B** – w/galvanized armor
- C5C** – w/SS armor
- C5D** – w/wire braid
- C5J** – w/plain leads

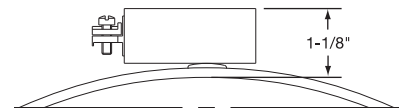

Two-Piece Band

Standard Termination Location:

next to same gap on each half; center of width

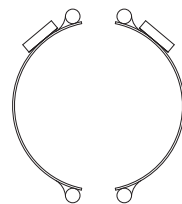

- * **Minimum Inside Diameter:** 3" (76.2 mm)
- * **Minimum Width:** 1" (25.4 mm) Heater widths between 1" and 2-1/2" require a minimum ID of 5-1/2" or greater.
- * **Max. Volts/Amps:** 480VAC/25A each half

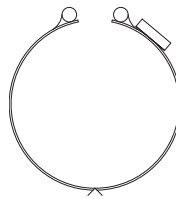

One-Piece Expandable Band

Standard Termination Location:
next to gap; center of width

- * **Minimum Inside Diameter:** 2-1/2" (63.5 mm)
- * **Minimum Width:** 1" (25.4 mm) Heater widths between 1" and 2-1/2" require a minimum ID of 5-1/2" or greater
- * **Maximum Volts/Amps:** 480VAC/25A

Quick Disconnect Plugs: Type P1, Type P2, Type P3 and Type P4

Available on any construction or clamping variation. These plug assemblies are highly recommended & should be used whenever possible. The combination of plug & cup assembly along with armor cable covered leads eliminates all live exposed terminals or wiring that can be a potential hazard to employees or machinery.

Type P1 and P3 assemblies are available with a straight or right-

angle plug. Type P2 and P4 plug assemblies have a lower profile and are available with a straight plug only.

To simplify installation, band heaters with these assemblies can be supplied pre-wired, using high temperature lead wires.

The standard leads are 10" of armor cable over 12" of flexible leads. *If longer leads are required, specify when ordering.*

Duraband® Type P1 – High Temperature Quick Disconnect Plugs

Type P1 □

- P1K** – Cup assembly only
- P1L** – w/straight plug only
- P1M** – w/90° plug only
- P1N** – w/str. plug & galvanized cable
- P1O** – w/str. plug & SS cable
- P1P** – w/str. plug & wire braid
- P1Q** – w/90° plug & galvanized cable
- P1R** – w/90° plug & SS cable
- P1S** – w/90° plug & wire braid

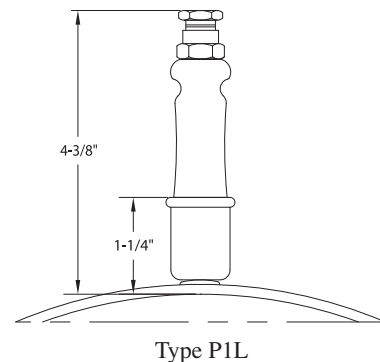
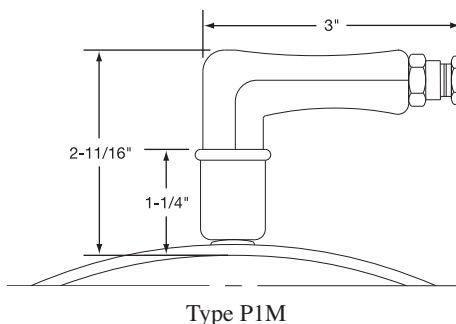

Plug Electrical Ratings

- * 2-Pole 3-Wire Grounding
- * Maximum Volts: 250 VAC
- * Maximum Amps: 16A
- * Maximum Temperature: 572°F (300°C)

One-Piece Band

Standard Termination Location:
next to gap; center of width

- * **Minimum Inside Diameter:** 2" (50.8 mm)
- * **Minimum Width:** 1-1/2" (38.1 mm)
If width is between 1-1/2" and 2", minimum diameter is 5-1/2".
If width is greater than 2", minimum diameter is 2".



Two-Piece Band

Standard Termination Location:
next to same gap on each half;
center of width

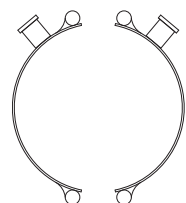

- * **Minimum Inside Diameter:** 2" (50.8 mm)
- * **Minimum Width:** 1-1/2" (38.1 mm)
If width is between 1-1/2" and 2", minimum diameter is 5-1/2".
If width is greater than 2", minimum diameter is 2".

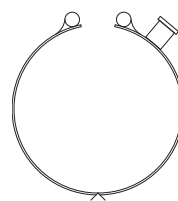

One-Piece Expandable Band

Standard Termination Location:
next to gap; center of width

- * **Minimum Inside Diameter:** 2-1/2" (63.5 mm)
- * **Minimum Width:** 1-1/2" (38.1 mm)
If width is between 1-1/2" and 2", minimum diameter is 5-1/2".
If width is greater than 2", minimum diameter is 2".



Terminations

Duraband® Type P2 – High Temperature Quick Disconnect Plugs

Continued from previous page...

Type P2 □ – Low Profile Assembly

- P2F** – Low profile assembly only
- P2G** – w/straight plug only
- P2H** – w/str. plug and galvanized cable
- P2J** – w/str. plug and SS cable
- P2K** – w/str. plug and wire braid

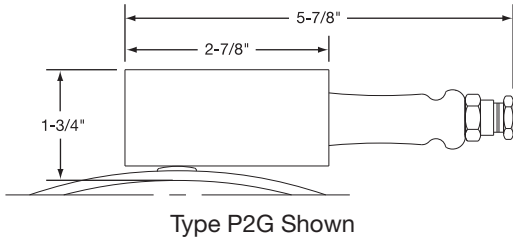

One-Piece Band

Standard Termination Location:
next to gap; center of width

- * **Minimum Inside Diameter:** 3" (76.2 mm)
- * **Minimum Width:** 2-1/2" (63.5 mm)

Plug Electrical Ratings

- * **2-Pole 3-Wire Grounding**
- * **Maximum Volts:** 250 VAC
- * **Maximum Amps:** 16A
- * **Maximum Temperature:** 572°F (300°C)

Two-Piece Band

Standard Termination Location:
next to same gap on each half;
center of width

- * **Minimum Inside Diameter:** 3" (76.2 mm)
- * **Minimum Width:** 2-1/2" (63.5 mm)

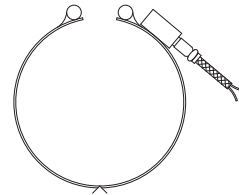
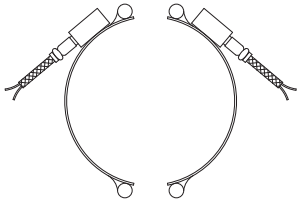

One-Piece Expandable Band

Standard Termination Location:
next to gap; center of width

- * **Minimum Inside Diameter:** 3" (76.2 mm)
- * **Minimum Width:** 2-1/2" (63.5 mm)

Duraband Type P3 – DIN 49458 A/B Quick Disconnect Plugs

One-Piece Band

Standard Termination Location:
next to gap; center of width

- * **Minimum Inside Diameter:** 3" (76.2 mm)
- * **Minimum Width:** 1-1/2" (38.1 mm)

Plug Electrical Ratings

- * **2-Pole 3-Wire Grounding**
- * **Maximum Volts:** 250 VAC
- * **Maximum Amps:** 16A
- * **Maximum Temperature:** 392°F (200°C)

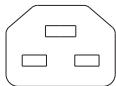

Standard Pin Orientation



Type P3 □ – Vertical Box Assembly

- P3A** – Box assembly only
- P3B** – Box assembly w/straight plug
- P3C** – Box assembly w/right-angle plug only

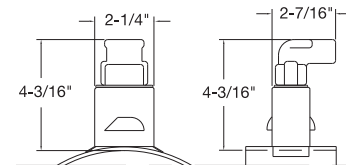

Two-Piece Band

Standard Termination Location:
next to same gap on each half;
center of width

- * **Minimum Inside Diameter:** 3" (76.2 mm)
- * **Minimum Width:** 1-1/2" (38.1 mm)

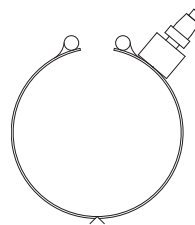
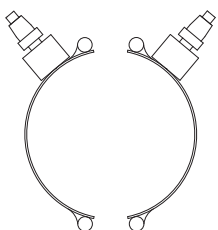

One-Piece Expandable Band

Standard Termination Location:
next to gap; center of width

- * **Minimum Inside Diameter:** 3" (76.2 mm)
- * **Minimum Width:** 1-1/2" (38.1 mm)

Duraband® Type P4 – DIN 49458 A/B Quick Disconnect Plugs

Type P4 □ – Horizontal Box Assembly

P4A – Box assembly only

P4B – Box assembly with straight plug

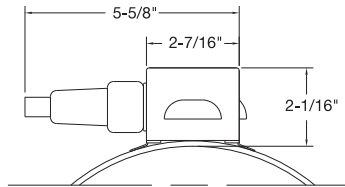

Plug Electrical Ratings

- * 2-Pole 3-Wire Grounding
- * Maximum Volts: 250 VAC
- * Maximum Amps: 16A
- * Maximum Temperature: 392°F (200°C)

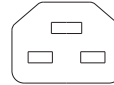

Standard Pin Orientation



Type P4C shown

One-Piece Band

Standard Termination Location:
next to gap; center of width

- * Minimum Inside Diameter: 3" (76.2 mm)
- * Minimum Width: 2-1/2" (63.5 mm)

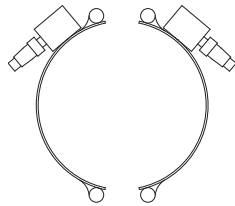

Two-Piece Band

Standard Termination Location:
next to same gap on each half;
center of width

- * Minimum Inside Diameter: 3" (76.2 mm)
- * Minimum Width: 2-1/2" (63.5 mm)

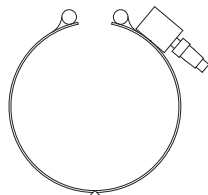

One-Piece Expandable Band

Standard Termination Location:
next to gap; center of width

- * Minimum Inside Diameter: 3" (76.2 mm)
- * Minimum Width: 2-1/2" (63.5 mm)

Special Duraband® Construction Options

Thermocouple Bayonet Adapter

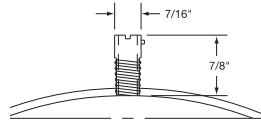

A standard Bayonet Adapter facilitates the installation of an external thermocouple with a standard bayonet cap. The standard location for the adapter is 90° from the gap. Specify without through hole for heater sensing or with through hole for load sensing. For heaters less than 1" wide order separate strap clamping and utilize the gap for the thermocouple.

Refer to pages 14-3 and 14-4 for a complete selection of thermocouples available from stock.

Thermocouple Coupling

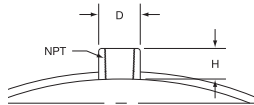

The Thermocouple Coupling facilitates the installation of an external thermocouple with a threaded fitting to sense the temperature of the band. The standard location for the coupling is 90° from the gap. Specify without through hole for heater sensing or with through hole for load sensing.

Available Bushing Sizes:

Thread	D	H
1/8-27 NPT	9/16"	5/8"
1/4-18 NPT	3/4"	11/16"
3/8-18 NPT	7/8"	5/8"
M12-1.75 mm	3/4"	1/2"



Holes and Cutouts

Holes and cutouts are normally required in band heaters for clearance for thermocouple probes or holding bolts. An oversize gap can in many cases serve the same purpose, saving the expense of the hole.

Using the center of the gap as a starting point, specify the location of the center-point of the hole or cutout in terms of degrees and the distance from the edge of the heater. In addition, state the size of the hole or cutout.

For critical hole and cutout locations, a detailed drawing will be required.



Note: A minimum of 1/2" is required from the hole to the edge of the heater.

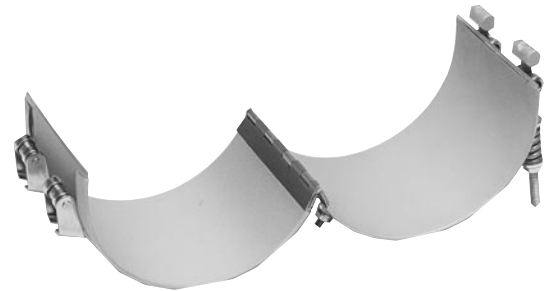

Hinged Two-Piece Band

The Hinged Two-Piece Band Heater is connected with a continuous hinge for easy installation and removal. This heater can be opened and closed as often as is necessary. The preferred method of clamping is latch and trunnion. It is available with any screw or lead variation. When ordering, specify watts and volts each half.

Minimum Width: 1-3/8" (34.9 mm)

Special Mica Insulated Heater Construction Variations

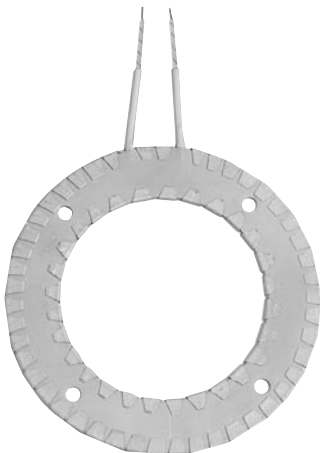

Ring Heaters

When ordering Ring Heaters, specify inside and outside diameters. If mounting holes are required, specify location and hole size. For critical hole and cutout locations, a detailed drawing will be required.

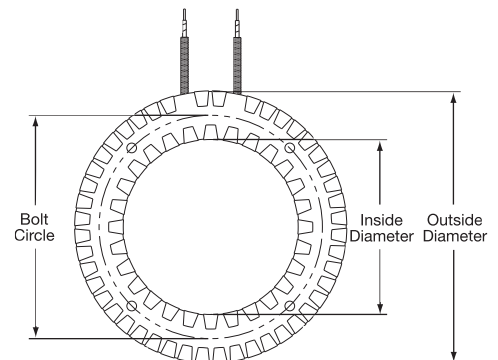

Special Mica Insulated Heater Construction Variations (continued)

Square, Rectangular, or Hexagon Bands

Square or Rectangular band heaters are normally used for heating dies on plastic extruders, or the barrels of twin screw extruders. They can be made in either one- or two-piece construction but two-piece construction with **Style 1** Clamping (see below) is recommended.

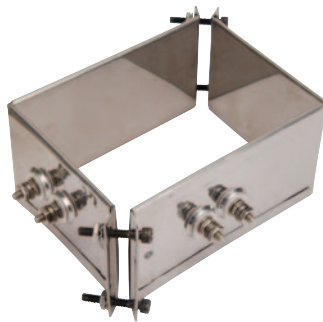

Hexagon shaped band heaters are used on the hex shaped portion of the nozzle on injection molding machines. These types of heaters are strictly made to customer specifications with bent-up flange clamping only.

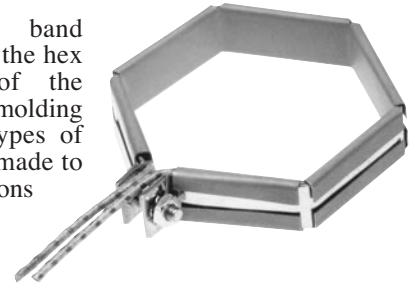

Clamping Styles – Three clamping styles are used on square and rectangular band heaters:

Style 1 for 2-piece heaters: bent-up flange clamping at the corners provides the most uniform clamping force and should be used whenever possible.

Maximum Recommended Watt Density: 25 w/in²

Style 2 for 2-piece heaters: bent-up flange clamping or built-in strap brackets at the sides requires a minimum “B” dimension of 3.75” (95.3 mm).

Maximum Recommended Watt Density: 20 w/in²

Style 3 for 1-piece heaters: bent-up flange clamping or built-in strap brackets at the sides requires a minimum “A” dimension of 3.75” (95.3 mm).

Maximum Recommended Watt Density: 25 w/in²

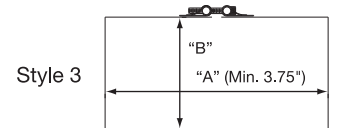
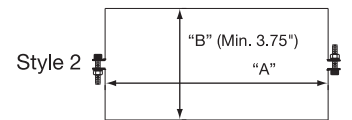
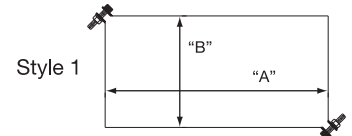

Ordering Information

- Square, Rectangular or Hex
- Select Clamping Style 1, 2 or 3
- Specify inside dimensions – Square or Rectangular: “A” and “B”
Hexagon: Specify internal dimension across flats
- Width: Minimum 3/4” (19.1 mm)
- Wattage: per half on two-piece heaters
- Voltage: per half on two-piece heaters
- Termination (see pages 1-32 through 1-45)
- Lead Cable/Braid Length
- Special Features (see page 1-46)
- Provide drawing or sample part when possible

⚠ WARNING: Cancer and Reproductive Harm - www.P65Warnings.ca.gov.

Cone Shapes

Cone Shaped Heaters are normally used for special heating applications when heat is required for hoppers or funnels. They are made strictly to customer specifications. The preferred method of attachment is with built-in bracket clamping. When ordering or for quoting purposes, supply a detailed drawing or sample part. Include the top ID, bottom ID, and the vertical rise or heater width.

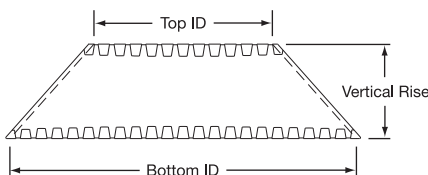

Duraband Features

Additional Duraband® Heater Features

Electrical Variations

Three-Phase On very high wattage band heaters it would be advantageous to set up the wiring three-phase to reduce the current load across a single conductor. Three-Phase wiring is available on select clamping/construction or termination variation (termination location is subject to engineering approval).

Min. ID: 3" (76.2 mm), **Min. Width:** 2" (50.8 mm)

Dual Voltage Band heaters can be designed using 3-wire series/parallel circuits for dual voltage applications. Whether the heater is run on the higher or lower voltage, the wattage will be the same. Dual Voltage wiring is available on any clamping/construction or termination variation.

Ground Terminal or Lead

For those applications requiring a separate ground terminal or lead attached to the heater sheath. A Ground Terminal or Lead is available on any clamping/construction or termination variation.

Single Phase/Three Phase Duraband Heaters can be designed with multiple circuits to operate single or three-phase.

Built-In Thermocouples

Heaters can be manufactured with a Built-In Thermocouple to closely control the temperature of the heater.

Type J or K thermocouples are available with fiberglass, wire braid or any other required insulation.

Consult Tempco with your requirements.

Construction Variations

All Stainless Steel Construction Mica band heaters can be constructed with the external sheath made entirely from stainless steel. This allows the Duraband to reach the maximum temperature of 1200°F (650°C). All Stainless Steel Construction is available on any clamping/construction or termination variation.

Other Sheath Materials Other sheath materials, such as rust-resistant steel, Monel®, aluminum, or copper are also available for unique applications.

CONSULT TEMPCO
WITH YOUR REQUIREMENTS –
WE HAVE THE RIGHT SOLUTIONS

Lead Variations

Electrical Plugs Industry standard NEMA Twist-Lock® electrical plugs are available. The plugs can be attached to fiberglass leads, armor cable or wire braid. Electrical Plugs can be added to any clamping/construction or termination variation.

See page 15-15 for additional Twist-Lock electrical plugs.

Terminal Lugs Various types of crimp terminals can be attached to the heater leads to make wiring into applications quick and easy. High temperature 1200°F (649°C) ring terminals and nylon or PVC insulated terminals are available. Spade, ring, and right-angle or straight quick disconnect type terminals can be attached to the leads.



Reference	NEMA P or R	Amps	Volts	Plug Part Number	Connectors (Female) Part Number
P4 twist lock	L5-15	15A	125V	EHD-102-113	EHD-103-104
P5 twist lock	L6-15	15A	250V	EHD-102-121	EHD-103-107
P9 twist lock	L2-20	20A	250V	EHD-102-104	N/A

Ordering Information

Custom Engineered/Manufactured Heaters

Understanding that an electric heater can be very application specific, for sizes not listed **TEMPCO** will design and manufacture a Duraband Heater to meet your requirements. **Standard lead time is 2 weeks.**

Please Specify the following:

- Inside Diameter
- Width
- Wattage
- Voltage
- Quantity
- Termination (see pages 1-32 through 1-45)
- Lead Cable/Braid Length
- Construction style (see pages 1-28, 1-46 and 1-47)
- Clamping variation (see pages 1-29 through 1-31)
- Special Features

Stock Heaters

Order by Part number for stock heaters listed on pages 1-52 through 1-59.

⚠ WARNING: Cancer and Reproductive Harm - www.P65Warnings.ca.gov.

Duraband® and Mica Insulated Heater Special Custom Designs

Variety and Versatility in Mica Insulated Heaters. No other heater band has the design and manufacturing flexibility of mica insulated heaters. Tempco's flexible CNC sheet metal fabricating machines, custom developed engineering programs with built-in intelligence, and experienced and talented engineering staff allow us to push the limits on band heater designs.

Throughout our catalog we show Tempco's standard specifications and most popular designs. However, as a custom heating element manufacturer, we recognize that many applications require non-standard and unique designs.

At Tempco, we are constantly challenged by our customers to solve their heating applications. We have the experience, technical knowledge and manufacturing capability to solve all your heating problems with unique heater designs. You should use

Tempco's talent and capabilities to your benefit to solve your specific heating problem in an expeditious and cost effective manner.

The following pictures show some of the heater designs that we have developed for special applications. Next time, when you have a special application and you want someone to work with you and "think outside the box" to solve your specific heating application, call Tempco.

We haven't seen all heating applications, but most likely our experienced staff has seen and solved more heating problems than you have seen.

Use our knowledge and experience to work for you. Challenge us! You will be glad you did.

We Welcome Your Inquiries.

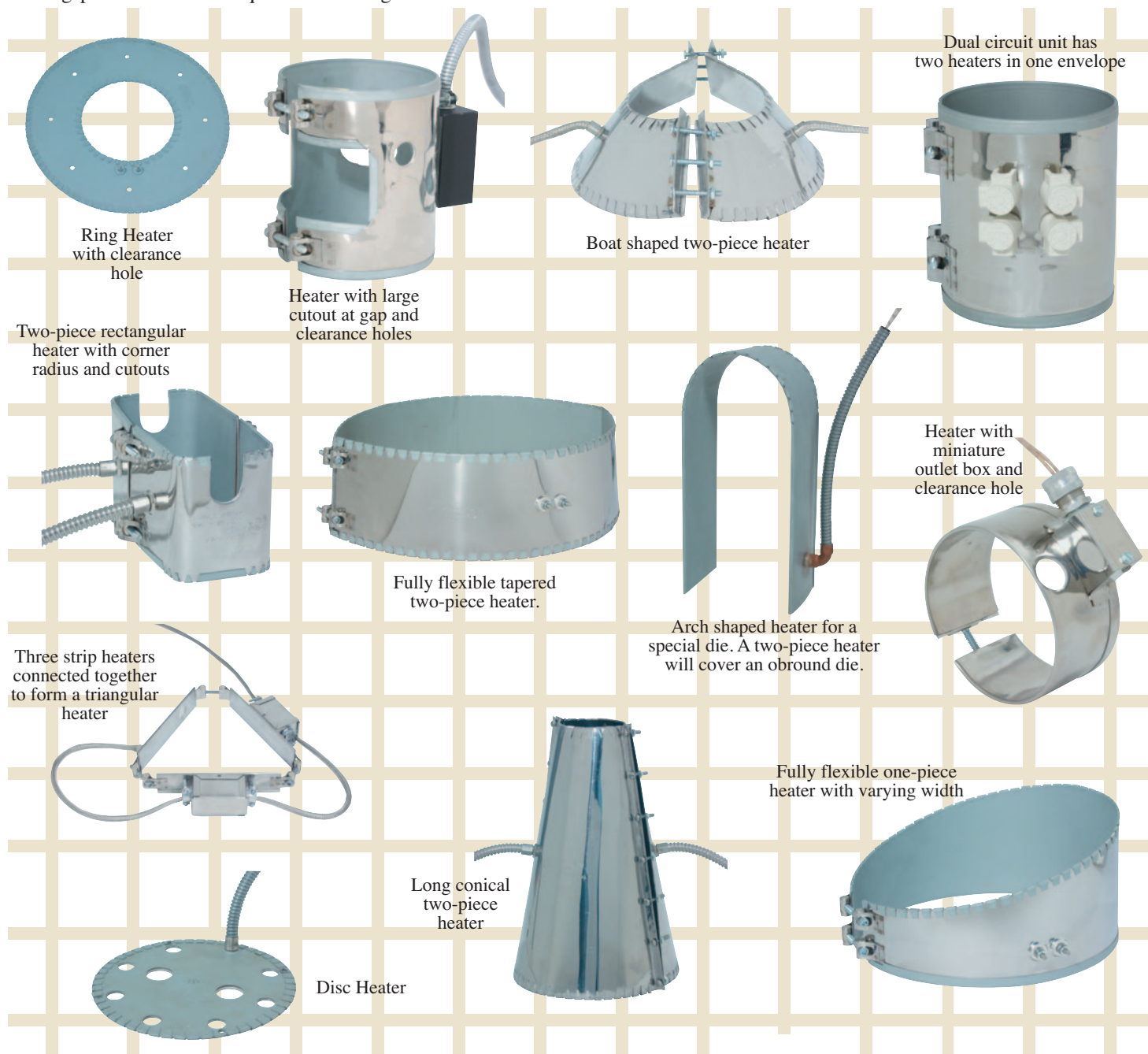

“Sinuated” Element Construction for Commercial OEM Applications



An alternative to wound ribbon core heaters is the sinuated heater element. In this type of construction, the heating element resistance wire is sinuated, or “formed” back and forth without a middle core layer of mica insulation. The heating element is then sandwiched between two layers of specially selected mica insulation to provide excellent thermal conductivity and dielectric strength.

The sinuated formed element lends itself to lower temperature and watt density applications where high watt density construction is not required.

Typical Applications (Cylindrical Surfaces)

- *Food and Candy Extruders*
- *Vending Machines*
- *Commercial Food Equipment*
- *Food Service Warming Items*
- *Laboratory and Scientific Apparatus*
- *Photographic Equipment*
- *Incubators*

The Solution for Low to Medium Temperature Cylindrical and Flat Surface Heating Applications

Typical Applications (Flat Surfaces)

- *Laminating*
- *Food Service Warming Items*
- *Radiant Heating*
- *Incubators*



This design is widely used in food service and the farming industry. By careful selection of economical materials used for these low temperature applications, significant cost savings can be realized compared to standard mica heaters.

Contact Tempco for Complete Product Details.

▼ Installation ▼ RECOMMENDATIONS

1. Disconnect electric power to the machine and/or heaters prior to installing or replacing heaters.
2. Do not install heaters in areas where combustible gases, vapor or dust is present.
3. Use as many narrow band heaters as the application will permit. 1-1/2" through 3" wide heaters are recommended.
4. Using a heater that closely matches the wattage requirements will decrease the frequency of cycling and temperature overshoot, thereby increasing the life of the heater.
5. Make certain that all barrel surfaces are clean and have a smooth finish. Any contaminants or imperfections on the surface can cause premature heater failure.
6. Tempco expandable type Mica Band Heaters may be opened once at the gap to fit on the barrel. Do not open these heaters beyond their specified heater diameter.



Do not open Tempco One-Piece Non-Expandable Type mica band Heaters. Opening of these heaters can damage Mica Insulation and will create electrical short circuits.

7. Position heater bands on the barrel.
8. Securely tighten heater bands around the barrel. Clamping force must be equally distributed on heaters with more than one set of clamping brackets.
Recommended clamping bolt torque is 10 ft./lbs.
9. For heaters with screw terminals, remove the top nut and flat washers from the power screw terminals. Do not remove or loosen the bottom nut on the power screw terminals. The bottom nut is tightened to 60 in./lbs. at the factory. A loose bottom nut may cause premature heater failure.

Installation

Accessories Available

IMMEDIATE DELIVERY!

- * High Temperature Terminal Lugs
- * Igloo™ Ceramic Terminal Covers
- * UL Listed Plugs
- * High Temperature Lead Wire 842°F (450°C)
- * Armor Cable
- * Stainless Steel Braid
- * High Temperature Sleaving
- * High Temperature Mica Insulated Wiring Harnesses 842°F (450°C)
- * Thermocouples
- * Temperature Controllers
- * High Temperature Fiberglass Tape

10. All electrical wiring of heater bands should be done by a qualified electrician.
 - a. Use only Stainless Steel or other high temperature lugs to prevent material degradation when exposed to high temperatures over a prolonged period of time.



DO NOT USE COPPER OR PLATED COPPER LUGS.

- b. Use only lead wire with high temperature insulation and proper gauge size.
 - c. When connecting power leads to screw terminals make certain that barrels of terminal lugs are not facing down toward the heater case, which will create a short circuit.
Tighten the top nut to 30 in/lbs.
 - d. Make certain power lead wires do not make contact with hot heater surface to avoid degradation of lead wire, as this can cause electrical short circuits.
 - e. Make sure the voltage input to the heater bands does not exceed the voltage rating that is stamped on the heater band.
 - f. It is recommended that an amperage reading is taken for each heater to verify proper wiring.
(Amps = Watts/Volts)

11. Insulate all live electrical wires per applicable safety standards.
12. Begin heater band re-tightening procedure. Be sure to wear protective gloves.
 - a. Energize heater bands and allow the heater to reach 300°F (149°C). This usually takes between 3 and 5 minutes.
 - b. Turn off power and immediately re-tighten the heater bands to 10 ft./lbs. Turn power back on.
13. Install shrouds around the machine to meet applicable safety requirements.
14. Once installed, check surroundings to make sure that contaminants won't get on the heater while the unit is in operation. Accumulation of contaminants on heaters can cause premature heater failure.
15. Insulating blanket installations must have band heater retightening sequence (#12) completed before blanket installation. Lead wires must exit the insulation blanket as soon as possible; do not entrap lead wires between heater sheath and insulation blanket.



It is imperative that upon start-up of new machines at customer facilities, all of the aforementioned parameters are double checked by qualified field service personnel.

Exposed electrical wiring on band heater installations is a violation of Electrical Safety Codes including O.S.H.A.

STOCK Replacement Band Heaters for Plastic Injection Molding Machines



**COST EFFECTIVE WITHOUT
COMPROMISING QUALITY**

NHL Mica Insulated Nozzle Heater

ID in	Width in	Watts	Watt Density W/in ²	Part Number	
				120V	240V
3/8	1	85	49	NHL00130	NHL00131
1	1	100	47	NHL00100	NHL00101
1	1	125	58	NHL00132	NHL00133
1	1 1/2	150	47	NHL00102	NHL00103
1	1 1/2	200	62	NHL00104	NHL00105
1	2	250	58	NHL00106	NHL00107
1 1/4	3/8	100	55	NHL00154	NHL00155
1 1/4	1	175	60	NHL00108	NHL00109
1 1/4	1 1/4	125	34	NHL00156	NHL00157
1 1/4	1 1/4	250	68	NHL00158	NHL00159
1 1/4	1 1/2	250	57	NHL00110	NHL00111
1 1/2	3/8	100	31	NHL00160	NHL00161
1 1/2	1	100	27	NHL00162	NHL00163
1 1/2	1	150	40	NHL00112	NHL00113
1 1/2	1	200	54	NHL00114	NHL00115
1 1/2	1 1/4	250	54	NHL00164	NHL00165
1 1/2	1 1/2	150	27	NHL00134	NHL00135
1 1/2	1 1/2	200	36	NHL00116	NHL00117
1 1/2	1 1/2	250	45	NHL00136	NHL00137
1 1/2	1 1/2	275	49	NHL00118	NHL00119
1 1/2	1 1/2	300	54	NHL00138	NHL00139
1 1/2	2	300	40	NHL00120	NHL00121
1 1/2	2 1/2	350	38	NHL00122	NHL00123
1 1/2	2 1/2	400	43	NHL00166	NHL00167
1 1/2	3	350	31	NHL00168	NHL00169
1 1/2	3	400	36	NHL00124	NHL00125
1 1/2	3	500	45	NHL00170	NHL00171
1 3/4	1	175	39	NHL00172	NHL00173
1 3/4	1 1/2	200	30	NHL00174	NHL00175
1 3/4	1 1/2	225	33	NHL00140	NHL00141
1 3/4	1 1/2	250	37	NHL00176	NHL00177
1 3/4	1 1/2	300	44	NHL00178	NHL00179
1 3/4	3	500	37	NHL00180	NHL00181
2	1	200	38	NHL00182	NHL00183
2	1 1/2	300	38	NHL00142	NHL00143
2	2	400	38	NHL00144	NHL00145
2 1/8	1	100	18	NHL00126	NHL00127
2 1/8	2	200	18	NHL00128	NHL00129
2 1/4	1	225	37	NHL00146	NHL00147
2 3/8	1	250	39	NHL00148	NHL00149
2 1/2	1	300	44	NHL00150	NHL00151
2 1/2	1 1/2	200	19	NHL00152	NHL00153
2 1/2	1 1/2	350	34	NHL00186	NHL00187

In Stock!

- * Economically Priced
- * Type NHL with 12" leads and 2" of protective sleeving
- * Supplied with low profile clamping strap

All Items Available from Stock



Note: For normal plastic processing Tempco recommends Watt Densities under 55 W/in².

STOCK Replacement Band Heaters for Plastic Injection Molding Machines



**COST EFFECTIVE WITHOUT
COMPROMISING QUALITY**

NHW Mica Insulated Nozzle Heater

ID in	Width in	Watts	Watt Density W/in ²	Part Number	
				120V	240V
7/8	1	85	49	NHW00130	NHW00131
1	1	100	47	NHW00100	NHW00101
1	1	125	58	NHW00132	NHW00133
1	1½	150	47	NHW00102	NHW00103
1	1½	200	62	NHW00104	NHW00105
1	2	250	58	NHW00106	NHW00107
1¼	1	175	60	NHW00108	NHW00109
1¼	1¼	125	34	NHW00156	NHW00157
1¼	1¼	250	68	NHW00158	NHW00159
1¼	1½	250	57	NHW00110	NHW00111
1½	7/8	100	31	NHW00160	NHW00161
1½	1	100	27	NHW00162	NHW00163
1½	1	150	40	NHW00112	NHW00113
1½	1	200	54	NHW00114	NHW00115
1½	1¼	250	54	NHW00164	NHW00165
1½	1½	150	27	NHW00134	NHW00135
1½	1½	200	36	NHW00116	NHW00117
1½	1½	250	45	NHW00136	NHW00137
1½	1½	275	49	NHW00118	NHW00119
1½	1½	300	54	NHW00138	NHW00139
1½	2	300	40	NHW00120	NHW00121
1½	2½	350	38	NHW00122	NHW00123
1½	2½	400	43	NHW00166	NHW00167
1½	3	400	36	NHW00124	NHW00125
1½	3	500	45	NHW00170	NHW00171
1¾	1½	200	30	NHW00174	NHW00175
1¾	1½	225	33	NHW00140	NHW00141
1¾	1½	250	37	NHW00176	NHW00177
1¾	1½	300	44	NHW00178	NHW00179
2	1½	300	38	NHW00142	NHW00143
2	2	400	38	NHW00144	NHW00145
2⅞	1	100	18	NHW00126	NHW00127
2⅞	1	200	35	NHW00184	NHW00185
2⅞	2	200	18	NHW00128	NHW00129
2¼	1	225	37	NHW00146	NHW00147
2⅜	1	250	39	NHW00148	NHW00149
2½	1	300	44	NHW00150	NHW00151
2½	1½	200	19	NHW00152	NHW00153
2½	1½	350	34	NHW00186	NHW00187
2¾	1½	400	35	NHW00188	NHW00189

In Stock!

- * Economically Priced
- * Type NHW with 12" leads and 10" SS wire braid
- * Supplied with low profile clamping strap

All Items Available from Stock

Ordering Information

See page 1-48



Note: For normal plastic processing Tempco recommends Watt Densities under 55 W/in².

Band Heaters



Duraband Nozzle Band Heaters

Stock and Standard (Non-Stock) Replacement Mica Insulated Band Heaters for Plastic Injection Molding Machines

Stock Items Are Shown In **RED**



Fig. A

ID		Width		Wattage	Fig.	Tempco Part Number	
in	mm	in	mm			120V	240V
1¼	31.8	1¾	30.2	125	A	—	MBH00033
1½	38.1	1	25.4	150	A	MBH00031	MBH00035
1½	38.1	1	25.4	150	A	—	MBH00036 ①
2⅝	58.7	1¾	36.5	300	A	—	MBH00038
2⅝	58.7	1¾	36.5	300	A	—	MBH00039 ①

① Heaters have built-in Type J Thermocouple

Stock Items Are Shown In **RED**

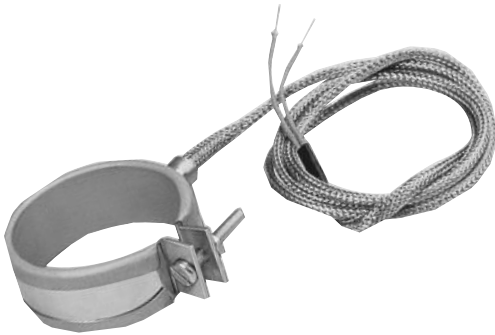

Fig. B

ID		Width		Wattage	Watt Density		Fig.	Part Number	
in	mm	in	mm		W/in ²	W/cm ²		120 Volts	240 Volts
1½	38.1	1	25.4	150	40	6.3	B	MBH00030	MBH00034
1¾	44.5	1	25.4	175	39	6.0	B	MBH00003	MBH00012
2	50.8	1	25.4	200	38	5.9	B	MBH00004	MBH00013
2¼	57.2	1	25.4	175	29	4.5	B	MBH00005	—
2¼	57.2	1½	38.1	300	33	5.1	B	—	MBH00037
2½	63.5	1	25.4	250	36	5.7	B	MBH00006	MBH00014
3	76.2	1	25.4	200	24	3.7	B	MBH00007	MBH00015
3½	88.9	1	25.4	300	30	4.7	B	MBH00009	MBH00016

Stock Items Are Shown In **RED**



Fig. C

ID		Width		Wattage	Watt Density		Fig.	Part Number
in	mm	in	mm		W/in ²	W/cm ²		240 V
1½	38.1	1½	38.1	275	49	7.7	C	MBH00019
1½	38.1	1¾	44.5	250	38	6.0	C	MBH00020
1½	38.1	2½	63.5	400	43	6.7	C	MBH00021
1½	38.1	3	76.2	450	40	6.3	C	MBH00022
1½	38.1	4½	114.3	600	36	5.6	C	MBH00023
1¾	44.5	6	152.4	800	30	4.6	C	MBH00024
2⅝	54.0	1⅝	23.8	215	40	6.3	C	MBH00025
2⅝	58.7	1⅝	23.8	260	44	6.9	C	MBH00026
2⅝	58.7	1⅝	34.9	240	28	4.3	C	MBH00027
2¼	69.9	1½	38.1	260	23	3.5	C	MBH00028

Design Features:

- * All heaters have 24" high temperature leads with 22" stainless steel overbraid

Ordering Information

See page 1-48

Stock and Standard (Non-Stock) Mica Insulated Band Heaters for Plastic Injection Molding Machines

Design Features:

- * All heaters have 24" high temperature leads with 22" stainless steel overbraid — **Type W3**
- * Heaters less than 1-1/2" wide have separate straps — **Type SE**
- * Designed as one-piece expandable type, enables you to open up the heater to the diameter of the barrel for easy installation.



Stock Items Are Shown In RED

ID		Width		Wattage	Watt Density		Style	Part Number		
in	mm	in	mm		W/in ²	W/cm ²		120V	240V	480V
2½	69.9	3½	88.9	600	22	3.5	NE	MBH00040	—	—
3	76.2	1	25.4	200	24	3.7	SE	MBH00041	MBH00054	—
3	76.2	1	25.4	250	30	4.7	SE	MBH00042	MBH00055	—
3	76.2	1	25.4	300	36	5.6	SE	MBH00043	MBH00056	—
3	76.2	1	25.4	400	48	7.4	SE	MBH00044	MBH00057	—
3	76.2	1½	38.1	500	40	6.1	NE	MBH00045	MBH00058	—
3	76.2	2½	63.5	300	14	2.2	NE	—	MBH00059	—
3½	88.9	¾	15.9	200	32	5.0	SE	MBH00046	MBH00060	—
3½	88.9	1	25.4	200	20	3.1	SE	MBH00047	—	—
3½	88.9	1½	38.1	500	33	5.2	NE	—	MBH00061	—
4	101.6	2	50.8	625	27	4.2	NE	MBH00048	MBH00062	MBH00066
4	101.6	3	76.2	500	14	2.2	NE	MBH00049	—	—
4	101.6	4	101.6	1250	27	4.2	NE	MBH00050	MBH00063	MBH00067
4½	114.3	1	25.4	300	23	3.5	SE	MBH00051	—	—
4½	114.3	2	50.8	700	27	4.1	NE	—	MBH00064	MBH00068
4½	114.3	4	101.6	700	13	2.1	NE	MBH00052	—	—
4½	114.3	4	101.6	1400	27	4.1	NE	MBH00053	MBH00065	MBH00069

Design Features:

- * All heaters have 24" high temperature leads — **Type L2**
- * Heaters less than 1-1/2" wide have separate straps — **Type SE**
- * Designed as one-piece expandable type, enables you to open up the heater to the diameter of the barrel for easy installation.



Stock Items Are Shown In RED

ID		Width		Wattage	Watt Density		Style	Part Number		
in	mm	in	mm		W/in ²	W/cm ²		120V	240V	480V
3	76.2	1	25.4	200	24	3.7	SE	MBH00070	MBH00078	—
3	76.2	1	25.4	250	30	4.6	SE	MBH00071	MBH00079	—
3	76.2	1	25.4	300	36	5.5	SE	MBH00072	MBH00080	—
3	76.2	1	25.4	400	47	7.4	SE	MBH00073	MBH00081	—
3	76.2	1½	38.1	400	32	4.9	NE	MBH00074	MBH00082	—
3	76.2	1½	38.1	450	36	5.5	NE	MBH00075	MBH00083	—
3	76.2	1½	38.1	500	40	6.1	NE	MBH00076	MBH00084	—
3	76.2	2	50.8	500	30	4.6	NE	MBH00077	MBH00085	—
3½	88.9	1	25.4	400	40	6.2	SE	—	MBH00086	—
3½	88.9	1½	38.1	250	17	2.6	NE	—	MBH00087	MBH00093
3½	88.9	2	50.8	650	33	5.0	NE	—	MBH00088	—
4½ ₁₆	125.4	2½	63.5	720	20	3.1	NE	—	MBH00089	MBH00094
5½	139.7	2½	63.5	950	23	3.6	NE	—	MBH00090	MBH00095
5½	149.2	1½	38.1	675	26	4.0	NE	—	MBH00091	MBH00096
7½	190.5	1½	38.1	1000	30	4.6	NE	—	MBH00092	MBH00097

Duraband Barrel Band Heaters

Stock and Standard (Non-Stock) Mica Insulated Band Heaters for Plastic Injection Molding Machines



Design Features:

- * All heaters have 24" high temperature leads with 22" stainless steel overbraid — **Type W1**
- * Heaters less than 1-1/2" wide have separate straps — **Type SE**
- * Designed as one-piece expandable type, enables you to open up the heater to the diameter of the barrel for easy installation.

Stock Items Are Shown In **RED**

ID		Width		Wattage	Watt Density		Style	Part Number	
in	mm	in	mm		W/in ²	W/cm ²		120V	240V
2½	63.5	1½	38.1	300	29	4.5	NE	MBH00098	—
3	76.2	1	25.4	300	36	5.6	SE	MBH00099	MBH00108
3	76.2	1½	38.1	500	40	6.2	NE	MBH00100	MBH00109
3	76.2	2	50.8	500	30	4.6	NE	MBH00101	MBH00110
3¾	79.4	2	50.8	450	26	4.0	NE	—	MBH00111
3¾	82.6	2	50.8	400	22	3.4	NE	—	MBH00112
3¾	88.9	1½	38.1	550	37	5.7	NE	—	MBH00113
3½	88.9	2	50.8	600	30	4.7	NE	—	MBH00114
3½	88.9	3	76.2	300	10	1.6	NE	—	MBH00115
3½	88.9	3	76.2	625	21	3.2	NE	—	MBH00116
3¾	95.3	1½	38.1	600	37	5.8	NE	MBH00102	MBH00117
3¾	95.3	2½	63.5	850	32	4.9	NE	MBH00103	MBH00118
4	101.6	1	25.4	550	48	7.4	SE	—	MBH00119
4	101.6	1½	38.1	550	32	4.9	NE	—	MBH00120
4¾	104.8	1	25.4	400	33	5.2	SE	MBH00104	—
4½	114.3	1	25.4	550	42	6.5	SE	—	MBH00121
4½	114.3	2	50.8	800	30	4.7	NE	—	MBH00122
4¾	120.7	¾	19.1	150	14	2.2	SE	—	MBH00123
4¾	123.8	1½	38.1	900	42	6.5	NE	—	MBH00124
5	127.0	1½	38.1	700	32	4.9	NE	—	MBH00125
5	127.0	1¾	44.5	600	23	3.6	NE	—	MBH00126
5	127.0	2	50.8	950	32	5.0	NE	—	MBH00127
5	127.0	2½	63.5	1000	27	4.2	NE	—	MBH00128
5½	139.7	1	25.4	550	34	5.2	SE	—	MBH00129
5½	139.7	1½	38.1	500	20	3.2	NE	—	MBH00130
5½	139.7	1½	38.1	900	37	5.7	NE	—	MBH00131
5½	139.7	2	50.8	500	15	2.4	NE	—	MBH00132
5½	139.7	2¾	69.9	620	14	2.1	NE	—	MBH00133
5½	139.7	3	76.2	1750	36	5.6	NE	—	MBH00134
6	152.4	1	25.4	300	17	2.6	SE	MBH00105	—
6	152.4	1½	38.1	500	19	2.9	NE	—	MBH00135
6	152.4	1½	38.1	850	32	4.9	NE	—	MBH00136
6¾	155.6	1	25.4	600	33	5.1	SE	MBH00106	—
6¾	158.8	2	50.8	500	13	2.1	NE	—	MBH00137
6¾	165.1	1½	38.1	750	26	4.0	NE	—	MBH00138
7	177.8	1	25.4	550	26	4.1	SE	—	MBH00139
7½	190.5	2	50.8	1500	36	5.6	NE	—	MBH00140
8¾	206.4	2	50.8	1200	38	5.9	NE	MBH00107	—
10	254.0	2	50.8	2000	41	6.4	NE	—	MBH00141

Ordering Information

See page 1-48

Stock and Standard (Non-Stock) Mica Insulated Band Heaters for Plastic Injection Molding Machines

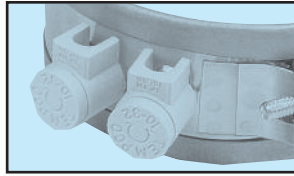

Optional Igloo™ ceramic covers can fully insulate any standard #8 or #10 terminal lugs used for electrical hook-ups. See page 1-33.

Design Features:

- * Features unbreakable 10-32 screw terminals.
- * Larger heaters (dia. 2-1/2" or greater) are designed as one-piece expandable type, enabling you to open up the heater to the diameter of the barrel for easy installation.
- * Heaters less than 1-1/2" wide have separate straps — **Type SE**

Stock Items Are Shown In RED

ID		Width		Wattage	Watt Density		Style	Term.	Part Number		
in	mm	in	mm		W/in ²	W/cm ²			120V	240V	480V
1½	38.1	1	25.4	150	40	6.3	SB	T2	—	MBH00170	—
1½	38.1	1½	38.1	250	45	7.0	NB	T2	—	MBH00171	—
1½	38.1	2	50.8	300	40	6.3	NB	T2	—	MBH00172	—
1¾	44.5	1	25.4	175	39	6.0	SB	T2	—	MBH00173	—
1¾	44.5	1½	38.1	250	37	5.7	NB	T2	—	MBH00174	—
1¾	44.5	1½	38.1	300	44	6.9	NB	T2	—	MBH00175	—
1⅞	47.6	1	25.4	200	41	6.3	SB	T2	—	MBH00176	—
2	50.8	1½	38.1	300	38	5.9	NB	T2	MBH00142	MBH00177	—
2¼	57.2	1	25.4	250	41	6.4	SB	T2	MBH00143	MBH00178	—
2¼	57.2	2	50.8	525	43	6.7	NB	T2	—	MBH00179	—
2½	60.3	1	25.4	100	15	2.4	SB	T2	—	MBH00180	—
2½	60.3	1	25.4	250	39	6.0	SB	T2	—	MBH00181	—
2½	60.3	2½	63.5	450	28	4.3	NB	T3	MBH00144	—	—
2½	63.5	1	25.4	225	33	5.1	SE	T2	—	MBH00182	—
2½	63.5	1	25.4	250	36	5.7	SE	T2	—	MBH00183	—
2½	63.5	1	25.4	275	40	6.2	SE	T2	—	MBH00184	—
2½	63.5	1½	38.1	300	29	4.5	NE	T2	MBH00145	MBH00185	—
2½	63.5	1½	38.1	350	34	5.3	NE	T2	MBH00146	MBH00186	—
2½	63.5	2½	60.3	550	34	5.2	NE	T2	—	MBH00187	—
2½	63.5	2½	73.0	650	33	5.1	NE	T3	—	MBH00188	—
2½	63.5	4	101.6	850	31	4.8	NE	T3	—	MBH00189	—
3	76.2	1	25.4	200	24	3.7	SE	T2	MBH00147	MBH00190	—
3	76.2	1	25.4	250	30	4.6	SE	T2	MBH00148	MBH00191	—
3	76.2	1	25.4	300	36	5.5	SE	T2	—	MBH00192	—
3	76.2	1	25.4	350	42	6.4	SE	T2	—	MBH00193	—
3	76.2	1	25.4	400	47	7.4	SE	T2	MBH00149	MBH00194	MBH00348
3	76.2	1½	38.1	400	32	4.9	NE	T2	MBH00150	MBH00195	—
3	76.2	1½	38.1	450	36	5.5	NE	T2	—	MBH00196	—
3	76.2	1½	38.1	500	40	6.1	NE	T2	MBH00151	MBH00197	—
3	76.2	2	50.8	450	27	4.1	NE	T2	—	MBH00198	—
3	76.2	2	50.8	500	30	4.6	NE	T2	—	MBH00199	—
3	76.2	2½	63.5	650	31	4.8	NE	T3	—	MBH00200	—
3⅞	79.4	1	25.4	300	34	5.3	SE	T2	—	MBH00201	—
3⅞	79.4	1	25.4	400	45	7.0	SE	T2	MBH00152	MBH00202	—
3⅞	79.4	1½	38.1	400	30	4.7	NE	T2	—	MBH00203	—
3⅞	82.6	1½	38.1	400	29	4.5	NE	T2	MBH00153	MBH00204	—
3½	88.9	1	25.4	300	30	4.7	SE	T2	MBH00154	MBH00205	—
3½	88.9	1½	38.1	325	22	3.4	NE	T2	—	MBH00206	—
3½	88.9	1½	38.1	400	27	4.1	NE	T2	MBH00155	—	—
3½	88.9	1½	38.1	500	33	5.2	NE	T2	MBH00156	MBH00207	—
3½	88.9	2	50.8	325	16	2.5	NE	T2	—	MBH00208	—
3½	88.9	2	50.8	500	25	3.9	NE	T2	MBH00157	—	—
3½	88.9	2	50.8	650	33	5.0	NE	T2	—	MBH00209	—
3½	88.9	2½	63.5	750	30	4.7	NE	T3	—	MBH00210	—
3½	88.9	3	76.2	1000	33	5.2	NE	T3	—	MBH00211	—
3⅞	90.5	2⅞	60.3	685	28	4.4	NE	T2	—	MBH00212	—
3⅞	92.2	1½	38.1	625	40	6.2	NE	T2	—	MBH00213	—
3¾	95.3	1	25.4	350	32	5.0	SE	T2	MBH00158	MBH00214	—
3¾	95.3	1½	38.1	500	31	4.8	NE	T2	—	MBH00215	—
3¾	95.3	1½	38.1	700	43	6.7	NE	T2	—	MBH00216	—
3¾	95.3	2½	63.5	850	32	4.9	NE	T3	MBH00159	MBH00217	—
3⅞	98.4	1½	38.1	550	33	5.1	NE	T2	—	MBH00218	—

CONTINUED →

Band Heaters



Duraband Barrel Band Heaters

Stock and Standard (Non-Stock) Mica Insulated Band Heaters for Plastic Injection Molding Machines

Continued from previous page...

ID		Width		Wattage	Watt Density		Style	Term.	Part Number		
in	mm	in	mm		W/in ²	W/cm ²			120V	240V	480V
3 ³ / ₈	98.4	2	50.8	750	34	5.2	NE	T2	—	MBH00219	—
3 ³ / ₈	100.0	2	50.8	600	26	4.1	NE	T2	—	MBH00220	—
4	101.6	1	25.4	400	35	5.4	SE	T2	MBH00160	MBH00221	—
4	101.6	1 ¹ / ₂	38.1	400	23	3.6	NE	T2	—	MBH00222	—
4	101.6	1 ¹ / ₂	38.1	550	32	4.9	NE	T2	—	MBH00223	—
4	101.6	1 ¹ / ₂	38.1	625	36	5.6	NE	T2	—	MBH00224	MBH00349
4	101.6	1 ¹ / ₂	38.1	750	43	6.7	NE	T2	—	MBH00225	—
4	101.6	2	50.8	550	24	3.7	NE	T2	MBH00161	MBH00226	—
4	101.6	2	50.8	800	35	5.4	NE	T2	—	MBH00227	—
4	101.6	2 ¹ / ₄	57.2	900	35	5.4	NE	T2	—	MBH00228	—
4	101.6	2 ¹ / ₂	63.5	1000	35	5.4	NE	T3	—	MBH00229	—
4	101.6	4	101.6	1250	27	4.2	NE	T3	—	MBH00230	—
4 ¹ / ₂	109.5	3 ¹ / ₂	88.9	1210	28	4.3	NE	T3	—	MBH00231	—
4 ¹ / ₂	114.3	1	25.4	350	27	4.1	SE	T2	MBH00162	MBH00232	—
4 ¹ / ₂	114.3	1 ¹ / ₂	38.1	350	18	2.8	NE	T2	—	MBH00233	—
4 ¹ / ₂	114.3	1 ¹ / ₂	38.1	400	20	3.1	NE	T2	—	MBH00235	—
4 ¹ / ₂	114.3	1 ¹ / ₂	38.1	650	33	5.1	NE	T2	—	MBH00236	—
4 ¹ / ₂	114.3	2	50.8	500	19	2.9	NE	T2	MBH00163	MBH00237	—
4 ¹ / ₂	114.3	2	50.8	700	27	4.1	NE	T2	MBH00164	MBH00238	—
4 ¹ / ₂	114.3	2 ¹ / ₂	63.5	1000	30	4.7	NE	T3	MBH00165	MBH00239	—
4 ³ / ₄	120.7	1 ¹ / ₂	38.1	600	29	4.5	NE	T2	—	MBH00242	MBH00350
4 ³ / ₄	120.7	1 ¹ / ₂	38.1	650	31	4.8	NE	T2	—	MBH00243	—
4 ³ / ₄	120.7	3	76.2	1100	26	4.1	NE	T3	—	MBH00244	MBH00351
4 ³ / ₈	123.8	1 ¹ / ₂	38.1	900	42	6.5	NE	T2	—	MBH00245	—
4 ³ / ₈	123.8	2	50.8	650	23	3.5	NE	T2	—	MBH00246	—
4 ³ / ₈	123.8	2	50.8	760	27	4.1	NE	T2	—	MBH00247	MBH00352
4 ³ / ₈	123.8	3	76.2	900	21	3.2	NE	T3	—	MBH00248	—
4 ¹ / ₂	125.4	3	76.2	1200	28	4.3	NE	T3	—	MBH00249	—
5	127.0	1	25.4	400	27	4.2	SE	T2	—	MBH00250	—
5	127.0	1 ¹ / ₂	38.1	350	16	2.5	NE	T2	—	—	MBH00353
5	127.0	1 ¹ / ₂	38.1	700	32	4.9	NE	T2	—	MBH00251	—
5	127.0	1 ¹ / ₂	38.1	800	36	5.6	NE	T2	—	MBH00252	—
5	127.0	2	50.8	1000	34	5.3	NE	T2	—	MBH00253	—
5	127.0	2 ¹ / ₂	63.5	1000	27	4.2	NE	T3	—	MBH00254	—
5	127.0	3	76.2	1200	27	4.2	NE	T3	—	MBH00255	MBH00354
5	127.0	3 ¹ / ₄	82.6	800	17	2.6	NE	T3	—	—	MBH00355
5	127.0	3 ³ / ₄	82.6	1250	26	4.1	NE	T3	—	MBH00256	—
5	127.0	4	101.6	1500	25	4.0	NE	T3	—	MBH00257	—
5 ¹ / ₈	130.2	1 ¹ / ₂	38.1	900	40	6.2	NE	T2	—	MBH00258	—
5 ¹ / ₈	130.3	1 ¹ / ₂	38.1	600	26	4.1	NE	T2	—	MBH00259	—
5 ¹ / ₄	133.4	1	25.4	500	32	5.0	SE	T2	—	MBH00260	—
5 ¹ / ₄	133.4	1	25.4	600	39	6.0	SE	T2	—	MBH00261	MBH00356
5 ¹ / ₄	133.4	1 ¹ / ₂	38.1	600	26	4.0	NE	T2	—	MBH00262	MBH00357
5 ¹ / ₄	133.4	1 ¹ / ₂	38.1	1000	43	6.7	NE	T2	—	MBH00263	—
5 ¹ / ₄	133.4	2	50.8	1000	32	5.0	NE	T2	—	MBH00264	—
5 ¹ / ₄	133.4	2 ¹ / ₄	57.2	1300	37	5.8	NE	T2	—	—	MBH00358
5 ¹ / ₄	133.4	2 ¹ / ₂	63.5	1300	34	5.2	NE	T3	—	MBH00265	—
5 ¹ / ₄	133.4	3	76.2	1700	37	5.7	NE	T3	—	MBH00266	—
5 ¹ / ₂	139.7	1 ¹ / ₂	38.1	800	33	5.1	NE	T2	—	MBH00267	—
5 ¹ / ₄	146.1	1 ¹ / ₂	38.1	600	23	3.6	NE	T2	—	MBH00268	—
5 ³ / ₈	149.2	3	76.2	1000	19	3.0	NE	T3	—	MBH00269	—
5 ¹ / ₂	150.8	1 ¹ / ₂	38.1	1000	38	5.9	NE	T2	—	MBH00270	—
6	152.4	1	25.4	500	28	4.3	SE	T2	—	MBH00271	—
6	152.4	1 ¹ / ₈	34.9	950	39	6.0	SE	T2	MBH00166	—	—
6	152.4	1 ¹ / ₂	38.1	600	22	3.5	NE	T2	—	MBH00272	—
6	152.4	1 ¹ / ₂	38.1	850	32	4.9	NE	T2	MBH00167	MBH00273	—
6	152.4	1 ¹ / ₂	38.1	900	34	5.2	NE	T2	—	MBH00274	—
6	152.4	1 ¹ / ₂	38.1	1000	40	6.2	NE	T2	—	MBH00275	—
6	152.4	2	50.8	1200	34	5.2	NE	T2	—	MBH00276	—
6	152.4	2 ¹ / ₂	63.5	1450	32	5.0	NE	T3	—	MBH00277	—
6	152.4	3	76.2	1400	26	4.1	NE	T3	—	MBH00278	MBH00359
6 ¹ / ₈	155.6	1 ¹ / ₂	38.1	1000	37	5.7	NE	T2	—	MBH00279	—
6 ¹ / ₄	158.8	3	76.2	1500	27	4.2	NE	T3	—	MBH00280	MBH00360
6 ¹ / ₂	160.3	3	76.2	1250	22	3.4	NE	T3	—	MBH00281	MBH00361
6 ¹ / ₂	164.3	2	50.8	800	21	3.2	NE	T2	—	MBH00282	—
6 ¹ / ₂	164.3	2	50.8	1200	33	5.1	NE	T2	—	MBH00283	—

Stock Items Are
Shown In **RED**

**Order
Info.**
See page 1-48

Stock and Standard (Non-Stock) Mica Insulated Band Heaters for Plastic Injection Molding Machines

ID		Width		Wattage	Watt Density		Style	Term.	120V	Part Number		
in	mm	in	mm		W/in ²	W/cm ²				240V	480V	
6½	165.1	1½	38.1	750	26	4.0	NE	T2	—	MBH00284	—	
6½	165.1	1½	38.1	900	31	4.8	NE	T2	—	MBH00285	—	
6½	165.1	1½	38.1	1200	41	6.4	NE	T2	—	MBH00286	—	
6½	165.1	2	50.8	1000	26	4.0	NE	T2	—	MBH00287	—	
6½	165.1	2½	63.5	1200	25	3.8	NE	T3	—	MBH00288	MBH00362	
6⅝	168.4	1½	38.1	815	27	4.2	NE	T2	—	MBH00289	—	
6⅝	168.4	1½	38.1	1150	39	6.0	NE	T2	—	MBH00290	—	
6¾	171.5	1½	38.1	600	20	3.1	NE	T2	—	MBH00291	—	
6¾	171.5	1½	38.1	815	27	4.2	NE	T2	—	MBH00292	—	
6¾	171.5	1½	38.1	1000	33	5.1	NE	T2	—	MBH00293	—	
6¾	171.5	1½	38.1	1150	38	5.9	NE	T2	—	MBH00294	—	
6¾	171.5	2	50.8	1300	32	5.0	NE	T2	—	MBH00295	—	
6¾	171.5	4	101.6	2600	32	5.0	NE	T3	—	MBH00296	—	
7	177.8	1	25.4	750	36	5.5	SE	T2	—	MBH00297	—	
7	177.8	1½	38.1	950	30	4.7	NE	T2	—	MBH00298	—	
7	177.8	1½	38.1	1000	32	4.9	NE	T2	—	MBH00299	—	
7	177.8	2½	63.5	1000	19	3.0	NE	T3	—	MBH00300	—	
7	177.8	3	76.2	1650	26	4.1	NE	T3	—	MBH00301	MBH00363	
7½	180.2	3½	88.9	1200	16	2.5	NE	T3	—	MBH00302	MBH00364	
7½	180.2	3½	88.9	1650	22	3.4	NE	T3	—	MBH00303	MBH00365	
7⅞	181.0	1½	38.1	1200	37	5.8	NE	T2	—	MBH00304	—	
7⅞	181.0	3½	88.9	1650	22	3.4	NE	T3	—	MBH00305	—	
7¾	184.2	2	50.8	900	21	3.2	NE	T2	—	MBH00306	—	
7½	190.5	1	25.4	700	31	4.8	SE	T2	MBH00168	—	—	
7½	190.5	1½	38.1	800	24	3.7	NE	T2	—	MBH00307	—	
7½	190.5	1½	38.1	1000	30	4.6	NE	T2	—	MBH00308	—	
7½	190.5	2	50.8	1500	36	5.2	NE	T2	—	MBH00309	—	
7½	190.5	3	76.2	1800	27	4.1	NE	T2	—	MBH00310	MBH00366	
7⅞	193.7	1½	38.1	1000	29	4.5	NE	T2	—	MBH00311	—	
7⅞	193.7	3	76.2	2000	29	4.5	NE	T2	—	MBH00312	—	
7¾	196.9	1½	38.1	1000	29	4.4	NE	T2	—	MBH00313	—	
7¾	200.0	1½	38.1	750	21	3.3	NE	T2	—	MBH00314	—	
7¾	200.0	1½	38.1	1000	28	4.4	NE	T2	—	MBH00315	—	
7¾	200.0	3	76.2	2000	28	4.4	NE	T3	—	MBH00316	—	
8	203.2	1	25.4	850	35	5.5	SE	T2	—	MBH00317	—	
8	203.2	1½	38.1	950	26	4.1	NE	T2	—	MBH00318	—	
8	203.2	1½	38.1	1200	33	5.1	NE	T2	—	MBH00319	MBH00367	
8	203.2	1½	38.1	1400	39	6.0	NE	T2	—	MBH00320	—	
8	203.2	2	50.8	1500	31	4.8	NE	T2	—	MBH00321	MBH00368	
8	203.2	3	76.2	2250	31	4.8	NE	T3	—	MBH00322	MBH00369	
8¼	209.6	2	50.8	1800	36	5.6	NE	T2	—	MBH00323	MBH00370	
8¼	209.6	4	101.6	3000	30	4.7	NE	T3	—	MBH00324	MBH00371	
8½	215.9	1½	38.1	1200	31	4.8	NE	T2	—	MBH00325	—	
8½	215.9	2	50.8	1600	31	4.8	NE	T2	—	MBH00326	—	
8¾	222.3	3	76.2	2000	25	3.9	NE	T3	—	MBH00327	MBH00372	
9	228.6	1½	38.1	1300	32	4.9	NE	T2	—	MBH00328	—	
9	228.6	1½	38.1	1500	37	5.7	NE	T2	—	MBH00329	MBH00373	
9	228.6	2	50.8	1800	33	5.1	NE	T2	—	MBH00330	—	
9½	241.3	1½	38.1	1600	40	5.7	NE	T2	—	MBH00331	—	
9½	241.3	2	50.8	1800	31	4.8	NE	T2	—	MBH00332	—	
9½	241.3	3	76.2	2000	23	3.6	NE	T3	—	MBH00333	MBH00374	
9¾	244.5	3	76.2	2000	23	3.5	NE	T3	—	MBH00334	MBH00375	
9¾	244.5	3	76.2	3000	34	5.3	NE	T3	—	MBH00335	MBH00376	
9¾	247.7	2	50.8	2000	34	5.2	NE	T2	—	MBH00336	—	
10	254.0	1½	38.1	1400	31	4.8	NE	T2	—	MBH00337	—	
10¼	260.4	3	76.2	2400	26	4.0	NE	T3	—	MBH00338	MBH00377	
10¼	260.4	4	101.6	3000	24	3.7	NE	T3	—	MBH00339	MBH00378	
10½	266.7	1½	38.1	1500	31	4.8	NE	T2	—	MBH00340	—	
10½	266.7	3	76.2	2400	25	3.9	NE	T3	—	MBH00341	MBH00379	
11	279.4	1½	38.1	1600	32	4.9	NE	T2	—	MBH00342	—	
11	279.4	2	50.8	2000	30	4.6	NE	T2	—	MBH00343	—	
11¼	285.8	3	76.2	2400	23	3.6	NE	T3	—	MBH00344	—	
11½	292.1	1½	38.1	800	15	2.4	NE	T2	MBH00169	—	—	
11½	292.1	1½	38.1	1800	34	5.3	NE	T2	—	MBH00345	—	
12	304.8	1½	38.1	2000	36	5.6	NE	T2	—	MBH00346	—	
12	304.8	2	50.8	2300	31	4.9	NE	T2	—	MBH00347	MBH00380	

Stock Items Are
Shown In **RED**

Order Info.
See page 1-48

Ceramic Insulated Band Heaters

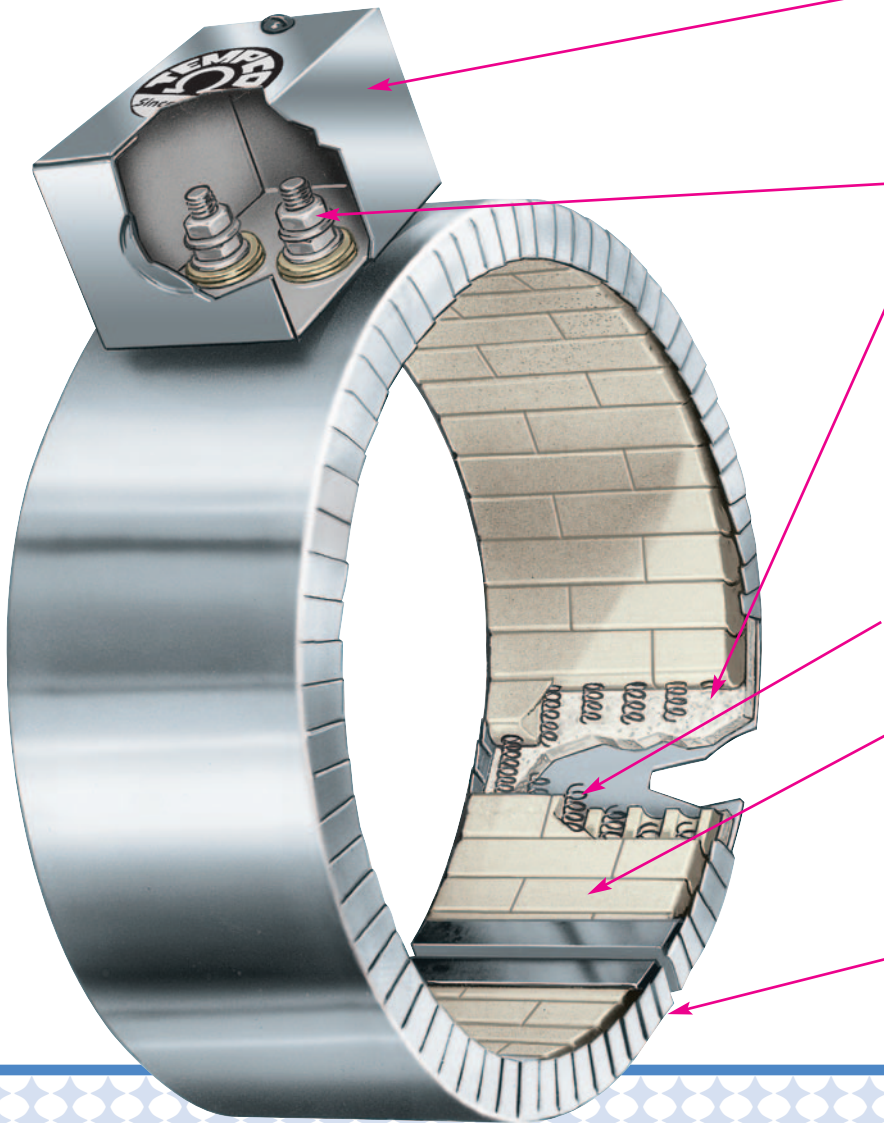

- A** General purpose terminal box offers excellent protection to exposed terminals. To simplify electrical wiring, the box has a 1/2" trade size knockout (actual dia. 7/8") that will accept standard conduit or flexible armor cable connectors.
- B** Stainless steel screw terminals connected to stranded nickel wire designed to provide maximum amperage carrying capacity.
- C** Built-In ceramic fiber insulation 1/4" thick standard on all Ceramic Bands will reduce power consumption by 25 to 30 percent. Further reduction can be obtained with optional 1/2" thick insulation. Specially designed mounting brackets with 1/4"-20 socket cap screws are used to securely draw the heating element assembly against the cylinder evenly and tightly across its entire width. Brackets are located 180° from the screw terminals.
- D** Helically wound nickel-chrome resistance wire strung through specially designed ceramic insulating bricks.
- E** Tempco's ceramic insulating bricks provide excellent dielectric strength at high temperatures and high voltages. Interlocking ceramic brick construction is used where applicable to allow for additional heater widths and to improve the rigidity of the heater.
- F** Stainless steel housing with serrated edges provides maximum flexibility for ease of installation.

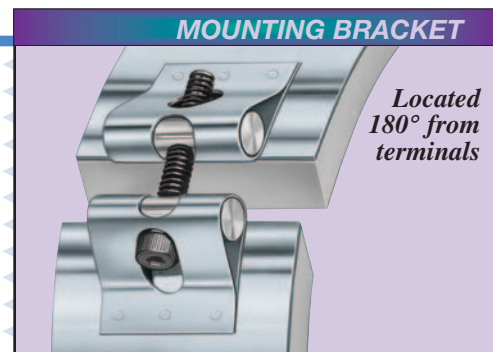

REDUCE HEAT LOSS

CONSERVE ENERGY

MAXIMIZE OPERATOR COMFORT

REDUCE OVERALL OPERATION COST

Ceramic Band Heaters Are Designed To Conserve Energy and Improve Operation Efficiency

Design Features

- * Built-In Thermal Insulation
- * Conserves Electrical Energy
- * Minimum Heat Loss
- * Fully Flexible For Easy Installation
- * Good Temperature Uniformity
- * Longer Heater Life
- * Various Constructions & Terminations
- * Heats Through Conduction and Radiation
- * Designed to Your Specifications

Tempco Ceramic Insulated Band Heaters

are specifically designed and engineered to meet the ever increasing demand for energy conservation and to improve operation efficiency. The Ceramic Band Heaters are capable of generating the higher temperatures essential to process today's high temperature resins. Electrical energy savings are achieved by using a 1/4" thick ceramic fiber insulating blanket, reducing power consumption by 25 to 30 percent. Because of the low thermal conductivity of the ceramic fiber insulation, the external surface temperature of the Ceramic Band Heater is approximately 400°F while running the inside surface temperature at 1200°F.

Ceramic Band Heaters transmit heat through both conduction and radiation. The element winding is designed to run at maximum temperature and heat the ceramic blocks to the point at which they radiate energy into the barrel as well as conduct energy by being in contact with the barrel. Therefore, the fit is not as critical as in other types of bands.

Tempco Ceramic Band Heaters have become extremely popular among Original Equipment Manufacturers as the standard heaters for the barrels of Plastic Injection Molding Machines, Extruders, and Blow Molding Equipment.

Variations and Advantages

Ceramic Band Heaters are manufactured in a full range of standard construction variations, physical dimensions, electrical ratings, and a complete arrangement of screw terminals and lead terminations.

However, these standard Ceramic Band Heater variations and terminations do not represent the extent of our capabilities. Tempco's engineering staff, with many years of experience in heat processing and temperature control applications, can assist you in designing the right Ceramic Band Heater for your specific application.

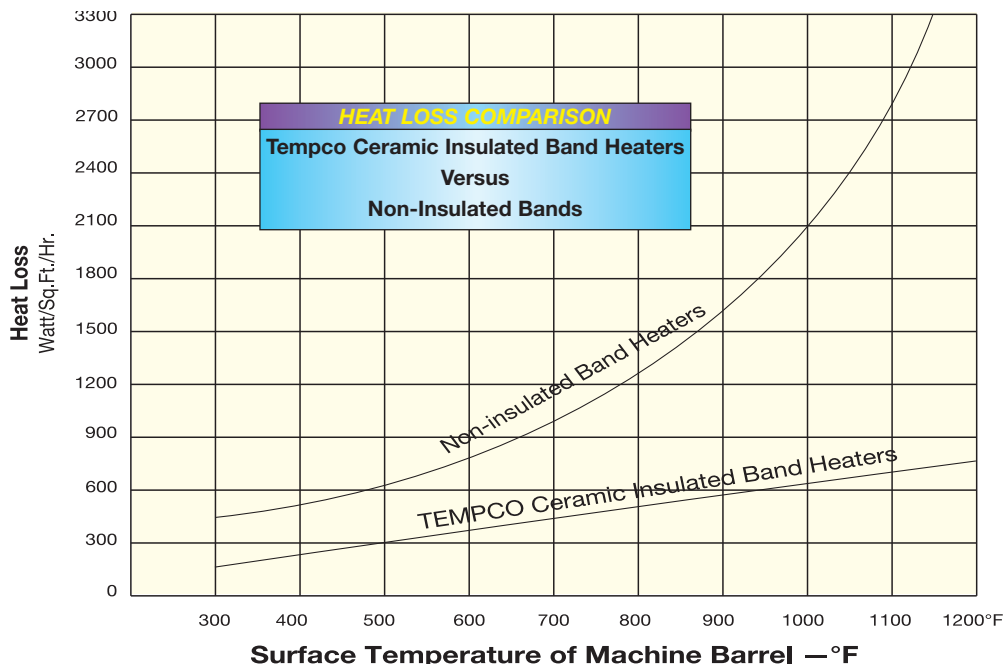

Construction Characteristics

Standard

The basic Tempco Ceramic Band Heater design consists of a helically wound resistance coil made from nickel-chrome wire, evenly stretched and precisely strung through specially designed ceramic insulating bricks, forming a flexible heating mat. The ceramic heating mat along with 1/4" thick ceramic fiber insulation is installed in a stainless steel housing made with serrated edges, providing maximum flexibility for ease of installation. This allows the use of wider band heaters, eliminating the need for numerous narrow width and two-piece band heaters.

Double Insulated

For situations requiring additional insulation for lower external temperatures and increased electrical energy savings, Tempco offers Double Insulated Ceramic Bands with a full 1/2" thick ceramic fiber insulation. This will decrease power consumption by 35 to 37 percent when compared to uninsulated band heaters.

Rib Cage (Type R) Ceramic Band Heater

When Ceramic Band Heaters are used on extruder barrels that require both heating and cooling, Tempco manufactures the **Rib Cage (Type R)** Air-Cooled Ceramic Band Heater in two watt density styles. See page 1-75 for details.

Ceramic Band Standard Specifications and Tolerances

PERFORMANCE RATINGS

Maximum Temperature: 1400°F (760°C)
Nominal Watt Density: 20-45 W/in² (3-7 W/cm²)
Maximum Watt Density: 45 W/in² (7 W/cm²)

ELECTRICAL RATINGS

Maximum Voltage: 480 VAC per termination
Dual Voltage: Available depending on heater configuration
Maximum Amperage per circuit:
 lead wire termination: 10 amp
 screw terminations: 25 amp
Resistance Tolerance: +10%, -5%
Wattage Tolerance: +5%, -10%



Exposed electrical wiring on band heater installations is a violation of Electrical Safety Codes including O.S.H.A.

PHYSICAL SIZE CONSTRUCTION LIMITATIONS

Sheath Material: Stainless Steel
Insulation Material: Ceramic Fiber Blanket
 Standard Thickness: 1/4" (6.4 cm)
 Double Thickness: 1/2" (12.7 cm)

Overall Thickness:

	Dia. less than 4"	Dia. 4" or greater
Standard	.5" (12.7 cm)	.625" (15.9 cm)
Double	.688" (17.5 cm)	.75" (19.1 cm)
Ribcage	.344" (8.7 cm)	.5" (12.7 cm)

Minimum Width: 1" (2.54 cm)

Standard Width Increments: 1/8" (3.2 cm)

Consult Tempco for non-standard widths.

Maximum Width: Dependent upon the ratio of diameter to width

Width Tolerance:

1" (25.4 cm) to 3-1/2" (88.9 cm): ±1/16" (±1.6 cm)
 4" (101.8 cm) to 6-1/2" (165.1 cm): ±1/8" (±3.2 cm)
 Over 6-1/2" (165.1 cm): ±1/4" (6.4 cm)

Minimum Diameter: 2" (50.8 cm)

Maximum Diameter—One-Piece: 21" (533.4 cm)

Two-Piece: 44" (1,117.6 cm)

Nominal Gap: 3/8" (9.5 cm)— If a larger gap is required for probes or thermocouples, specify when ordering.

If tighter tolerances are required consult Tempco.

Construction Clamp	Min. ID		Min. Width		Max. ID	
	in	mm	in	mm	in	mm
One-Piece	2	50.8	1	25.4	21	533.4
Two-Piece	4	101.6	1	25.4	44	1117.6
Standard Insulation	2	50.8	1	25.4	N/A	
Double Insulation	2	50.8	1	38.1	N/A	
Rib Cage (RCC)	3	76.2	1	114.3	N/A	
Built-In Bracket	2	50.8	1	25.4	N/A	
Built-In Bracket Spring Loaded	2	50.8	1	25.4	N/A	
Latch and Trunnion	4	101.6	1	25.4	N/A	
Bent-Up Flange	2	50.8	1	25.4	N/A	
Shell Overlap	3	76.2	1	38.1	20	508.0



Note: Refer to individual construction and termination descriptions on pages 1-66 through 1-74 for further information. Actual heater minimums and maximums will depend upon the combination of construction/clamp, termination styles and electrical ratings.



Ceramic Band

Standard (Non-Stock) Ceramic Bands

ID		Width		Wattage	Watt Density		Terminal	Part Number			
in	mm	in	mm		W/in ²	W/cm ²		120V	240V	480V	240/480V
2 ³ / ₈	60.3	1 ¹ / ₂	38.1	250	26	4.0	T2	—	BCH00017	—	—
2 ³ / ₈	60.3	6	152.4	1000	26	4.0	T3	—	BCH00018	—	—
2 ¹ / ₂	63.5	1	25.4	375	55	8.5	R2A	—	BCH00019	—	—
3	76.2	1	25.4	400	47	7.4	T2	—	BCH00020	—	—
3	76.2	1	25.4	500	59	9.2	R2A	—	BCH00021	—	—
3	76.2	1 ¹ / ₂	38.1	500	40	6.1	T2	BCH00001	BCH00022	—	—
3	76.2	2 ¹ / ₂	63.5	1000	47	7.4	T3	BCH00002	—	—	—
3	76.2	3	76.2	1100	44	6.7	T3	—	BCH00023	—	—
3	76.2	4	101.6	450	13	2.1	C2A	—	BCH00024	—	—
3	76.2	4	101.6	1500	45	6.9	T3	—	BCH00025	—	—
3	76.2	6	152.4	1500	30	4.6	T3	BCH00003	BCH00026	—	—
3	76.2	6	152.4	1500	30	4.6	C2A	—	BCH00027	—	—
3 ¹ / ₂	88.9	2	50.8	650	33	5.0	T3	—	—	—	BCH00163
3 ¹ / ₂	88.9	2	50.8	700	35	5.4	W1	—	BCH00028	—	—
3 ¹ / ₂	88.9	2	50.8	850	43	6.6	T3	—	BCH00029	—	—
3 ¹ / ₂	88.9	3	76.2	875	29	4.5	T3	—	BCH00030	—	—
3 ¹ / ₂	88.9	3	76.2	1000	33	5.2	T3	—	BCH00031	—	—
3 ¹ / ₂	88.9	4	101.6	1200	30	4.7	T3	BCH00004	BCH00032	—	—
3 ¹ / ₂	88.9	4 ¹ / ₂	114.3	1200	27	4.1	C2A	—	BCH00033	—	—
3 ¹ / ₂	88.9	5	127.0	2300	46	7.1	T3	—	BCH00034	—	—
3 ¹ / ₂	88.9	6	152.4	2970	50	7.7	T3	—	BCH00035	—	—
3 ³ / ₄	95.3	1 ¹ / ₂	38.1	460	28	4.4	T2	—	BCH00036	—	—
3 ⁵ / ₁₆	100.0	4	101.6	1140	25	3.9	T3	—	BCH00037	—	—
4	101.6	2	50.8	460	20	3.1	T3	—	BCH00038	—	—
4	101.6	2	50.8	1000	43	6.7	T2	—	—	BCH00120	—
4	101.6	2 ¹ / ₂	63.5	600	21	3.2	C2A	—	—	BCH00121	—
4	101.6	3	76.2	950	27	4.2	T3	—	—	—	BCH00164
4	101.6	3	76.2	1200	35	5.4	T3	BCH00005	BCH00039	—	—
4	101.6	4	101.6	1200	26	4.0	C2A	—	BCH00040	—	—
4	101.6	10	254.0	4500	39	6.0	T3	—	BCH00041	—	—
4	101.6	11	279.4	5000	39	6.1	T3	—	BCH00042	—	—
4 ¹ / ₄	108.0	2 ¹ / ₂	63.5	950	31	4.8	CSE	—	—	BCH00122	—
4 ¹ / ₂	114.3	2	50.8	1100	42	6.5	T3	BCH00006	BCH00043	—	—
4 ¹ / ₂	114.3	3	76.2	900	23	3.5	T3	BCH00007	BCH00044	—	—
4 ¹ / ₂	114.3	4	101.6	2300	44	6.8	T3	—	BCH00045	—	—
4 ¹ / ₂	114.3	4 ¹ / ₂	114.3	1400	24	3.7	CSE	—	—	—	BCH00165
4 ¹ / ₂	114.3	6	152.4	2000	25	3.9	T3	BCH00008	BCH00046	—	—
4 ³ / ₄	123.8	4	101.6	2000	35	5.4	T3	—	BCH00047	—	—
4 ⁵ / ₁₆	125.4	2	50.8	1000	34	5.3	L1	—	—	BCH00123	—
4 ⁵ / ₁₆	125.4	2 ¹ / ₂	63.5	1650	45	7.0	T3	—	—	BCH00124	—
4 ⁵ / ₁₆	125.4	4	101.6	2000	34	5.3	T3	—	—	BCH00125	—
5	127.0	1 ¹ / ₂	38.1	800	36	5.6	T2	—	BCH00048	BCH00126	—
5	127.0	2	50.8	1200	41	6.3	T3	—	BCH00049	—	—
5	127.0	3	76.2	1200	27	4.2	T2	—	BCH00050	—	—
5	127.0	3 ¹ / ₂	88.9	2200	43	6.6	T3	—	BCH00051	—	—
5	127.0	4	101.6	1500	25	4.0	CSE	—	BCH00052	—	—
5	127.0	4	101.6	2200	37	5.8	T3	—	BCH00053	—	—
5	127.0	6	152.4	3000	34	5.3	T3	—	BCH00054	—	—
5 ¹ / ₄	133.4	3	76.2	1500	32	5.0	T3	—	BCH00055	—	—
5 ¹ / ₂	139.7	1 ¹ / ₂	38.1	770	32	4.9	T3	—	—	BCH00127	—
5 ¹ / ₂	139.7	2	50.8	1000	31	4.8	T3	—	BCH00056	—	—
5 ¹ / ₂	139.7	2 ¹ / ₂	63.5	1800	44	6.9	C2A	—	BCH00057	—	—
5 ¹ / ₂	139.7	3	76.2	1200	25	3.8	T2	—	BCH00058	—	—
5 ¹ / ₂	139.7	4	101.6	1500	23	3.6	T3	—	—	—	BCH00166
5 ¹ / ₂	139.7	4	101.6	2000	31	4.8	T3	—	BCH00059	—	—
5 ¹ / ₂	139.7	5	127.0	2000	25	3.8	T3	BCH00009	BCH00060	—	—
5 ³ / ₈	149.2	5	127.0	2350	27	4.2	T3	—	—	BCH00128	—
5 ⁵ / ₁₆	150.8	5	127.0	2350	27	4.1	T3	—	BCH00061	—	—

Ordering Information
See page 1-65

CONTINUED



Standard Sizes and Ratings

Standard (Non-Stock) Ceramic Bands

Continued from previous page...

ID		Width		Wattage	Watt Density		Terminal	Part Number			
in	mm	in	mm		W/in ²	W/cm ²		120V	240V	480V	240/480V
6	152.4	1½	38.1	950	35	5.5	T2	BCH00010	BCH00062	—	—
6	152.4	2	50.8	1900	53	8.2	T3	—	BCH00063	BCH00129	—
6	152.4	2½	63.5	1600	36	5.6	C2A	—	BCH00064	BCH00130	—
6	152.4	3	76.2	1400	26	4.1	T3	—	—	—	BCH00167
6	152.4	4	101.6	1300	18	2.8	T3	BCH00011	BCH00065	—	—
6	152.4	5	127.0	1600	18	2.8	CSE	—	—	—	BCH00168
6	152.4	5½	139.7	2000	20	3.2	T3	—	—	—	BCH00169
6	152.4	6	152.4	2000	19	2.9	T3	—	—	—	BCH00170
6	152.4	6	152.4	3000	28	4.3	T3	—	BCH00066	—	—
6	152.4	6	152.4	4000	37	5.8	T3	—	BCH00067	—	—
6¼	158.8	4	101.6	2430	33	5.1	T3	—	BCH00068	—	—
6¼	158.8	6	152.4	4600	41	6.4	T3	—	—	BCH00131	—
6½	165.1	1½	38.1	1000	34	5.3	T2	—	BCH00069	—	—
6½	165.1	2	50.8	1600	41	6.4	T3	—	BCH00070	—	—
6½	165.1	3½	88.9	1800	26	4.1	T3	BCH00012	BCH00071	—	—
6½	165.1	5	127.0	2500	26	4.0	T3	—	BCH00072	—	—
6½	165.1	5½	139.7	4200	39	6.1	T3	—	—	BCH00132	—
6½	165.1	6	152.4	2000	17	2.7	CSE	—	—	—	BCH00171
6½	165.1	6½	165.1	3700	29	4.5	T3	—	BCH00073	—	—
6¾	168.3	4½	114.3	3300	37	5.7	T3	—	—	BCH00133	—
6¾	171.5	1½	38.1	1000	33	5.1	T2	BCH00013	BCH00074	—	—
6¾	171.5	5	127.0	2500	25	3.8	CSE	—	BCH00075	—	—
7	177.8	2	50.8	1400	33	5.2	C2A	—	—	BCH00134	—
7	177.8	3	76.2	1650	26	4.1	T3	—	BCH00076	—	—
7	177.8	3½	88.9	1300	18	2.7	T3	BCH00014	BCH00077	—	—
7	177.8	4	101.6	3500	42	6.5	T3	—	BCH00078	BCH00135	—
7	177.8	5½	139.7	2000	17	2.7	CSE	—	BCH00079	—	BCH00172
7	177.8	6	152.4	5400	43	6.6	T3	—	BCH00080	—	—
7½	190.5	2	50.8	1900	42	6.5	T3	—	BCH00081	—	—
7½	190.5	3	76.2	1800	27	4.1	T3	—	BCH00082	BCH00136	—
7½	190.5	4½	114.3	2000	20	3.1	T3	—	—	—	BCH00173
7½	190.5	4½	114.3	2000	20	3.1	T3	BCH00015	BCH00083	—	—
7½	190.5	5	127.0	2500	22	3.4	C2A	—	BCH00084	—	—
7½	190.5	5½	139.7	2500	20	3.1	T3	BCH00016	—	—	BCH00174
7½	190.5	7	177.8	6500	41	6.4	T3	—	—	—	BCH00175
7½	190.5	9	228.6	5710	28	4.4	T3	—	—	BCH00137	—
8	203.2	1½	38.1	770	21	3.3	T2	—	BCH00085	—	—
8	203.2	1½	38.1	1000	28	4.3	T2	—	—	BCH00138	—
8	203.2	2	50.8	2000	41	6.4	T3	—	BCH00086	—	—
8	203.2	2½	63.5	1000	17	2.6	T2	—	—	BCH00140	—
8	203.2	3	76.2	1900	26	4.1	T3	—	—	—	BCH00176
8	203.2	4	101.6	3000	31	4.8	T3	—	BCH00087	—	—
8	203.2	6	152.4	3500	24	3.7	T3	—	BCH00088	—	—
8	203.2	6	152.4	4500	31	4.8	T3	—	—	BCH00141	—
8	203.2	6½	165.1	2600	17	2.6	CSE	—	—	—	BCH00177
8¼	204.8	4	101.6	2100	22	3.3	T3	—	—	BCH00142	—
8¼	204.8	4	101.6	2800	29	4.5	T3	—	—	BCH00143	—
8¼	204.8	9	228.6	4900	22	3.5	T3	—	—	BCH00144	—
8¼	209.6	3	76.2	2300	31	4.8	CSE	—	BCH00089	—	—
8¼	209.6	7½	190.5	3100	17	2.6	CSE	—	—	—	BCH00178
8½	214.3	3	76.2	3000	39	6.1	T3	—	—	BCH00145	—
8½	214.3	3½	88.9	2800	31	4.9	T3	—	BCH00090	BCH00146	—
8½	214.3	3½	88.9	3255	36	5.7	T3	—	—	—	—
8½	214.3	4	101.6	3400	33	5.2	T3	—	BCH00091	BCH00147	—
8½	214.3	5½	139.7	3800	27	4.2	T3	—	—	BCH00148	—
8½	215.9	1½	38.1	1250	32	5.0	C2A	—	BCH00092	BCH00149	—
8½	215.9	4½	114.3	3890	34	5.2	T3	—	BCH00093	—	—
8¾	222.3	9	228.6	4100	17	2.7	CSE	—	—	—	BCH00179
9	228.6	1½	38.1	1100	27	4.2	T2	—	—	BCH00150	—
9	228.6	2	50.8	2300	42	6.5	T3	—	BCH00094	—	—
9	228.6	2½	63.5	2800	41	6.4	T3	—	BCH00095	—	—
9	228.6	3	76.2	2200	27	4.2	T3	—	—	—	BCH00180
9	228.6	5	127.0	2500	18	2.8	T3	—	—	—	BCH00181
9	228.6	5½	139.7	3000	20	3.1	T3	—	BCH00096	—	BCH00182
9	228.6	8½	215.9	3900	17	2.6	CSE	—	—	—	BCH00183



Standard (Non-Stock) Ceramic Bands

Continued from previous page...

ID	Width		Wattage	Watt Density		Terminal	Part Number				
	in	mm		W/in ²	W/cm ²		120V	240V	480V	240/480V	
9 ⁷ / ₁₆	239.7	3	76.2	2500	29	4.5	T3	—	BCH00097	BCH00151	—
9 ¹ / ₂	241.3	1 ¹ / ₂	38.1	1200	28	4.3	T2	—	—	BCH00152	—
9 ¹ / ₂	241.3	3	76.2	2200	25	3.9	T3	—	—	—	BCH00184
9 ¹ / ₂	247.7	10	254.0	5200	18	2.7	C5E	—	—	—	BCH00185
10	254.0	1 ¹ / ₂	38.1	600	13	2.0	T2	—	BCH00098	—	—
10	254.0	2	50.8	1800	30	4.6	C2A	—	BCH00099	—	—
10	254.0	3	76.2	2400	26	4.1	T3	—	—	—	BCH00186
10	254.0	4	101.6	1500	12	1.9	C2A	—	BCH00100	—	—
10	254.0	5	127.0	2800	18	2.9	C5E	—	—	—	BCH00187
10	254.0	5 ¹ / ₂	139.7	2500	15	2.3	T3	—	BCH00101	—	—
10	254.0	6	152.4	3000	16	2.5	C2A	—	BCH00102	—	—
10 ¹ / ₂	266.7	4 ¹ / ₂	114.3	5000	35	5.4	C2A	—	BCH00103	—	—
11	279.4	3	76.2	2600	26	4.0	T3	—	—	—	BCH00188
11	279.4	5	127.0	4000	24	3.7	T3	—	—	—	BCH00189
11 ¹ / ₆	281.0	4	101.6	4000	30	4.6	T3	—	—	BCH00153	—
12	304.8	2	50.8	2000	27	4.2	C2A	—	BCH00104	—	—
12	304.8	3	76.2	2000	18	2.8	C2A	—	—	—	BCH00190
12	304.8	6	152.4	4000	18	2.8	T3	—	—	—	BCH00191
12	304.8	12	304.8	2000	5	0.7	T3	—	BCH00105	—	—
12 ¹ / ₂	317.5	4	101.6	1950	13	2.0	C2A	—	BCH00106	—	—
12 ¹ / ₂	317.5	4	101.6	2600	17	2.6	T3	—	BCH00107	—	—
13	330.2	2	50.8	2000	25	3.9	C5E	—	BCH00108	—	—
13	330.2	3	76.2	4200	35	5.4	T3	—	—	—	BCH00192
13	330.2	6	152.4	4000	17	2.6	T3	—	BCH00109	—	—
14 ¹ / ₂	368.3	3	76.2	2300	17	2.7	T3	—	—	BCH00154	—
15 ¹ / ₄	387.4	2	50.8	3000	32	5.0	C2A	—	BCH00110	—	—
16	406.4	2	50.8	1500	15	2.4	C2A	—	BCH00111	—	—
16	406.4	3	76.2	5000	34	5.2	C2A	—	BCH00112	—	—
16 ¹ / ₂	419.1	2	50.8	3000	30	4.6	C2A	—	BCH00113	—	—
16 ¹ / ₂	419.1	3	76.2	5400	35	5.5	C2A	—	BCH00114	—	—
16 ¹ / ₂	419.1	3 ¹ / ₂	88.9	1800	10	1.6	C2A	—	—	BCH00155	—
16 ¹ / ₂	419.1	3 ¹ / ₂	88.9	2500	14	2.2	T3	—	BCH00115	—	—
16 ¹ / ₂	419.1	4	101.6	3500	17	2.7	C2A	—	BCH00116	—	—
16 ¹ / ₂	419.1	5	127.0	4350	17	2.7	T3	—	BCH00117	—	—
17 ¹ / ₂	444.5	1 ¹ / ₂	38.1	825	10	1.6	C2A	—	BCH00118	—	—
19 ¹ / ₄	489.0	2 ¹ / ₂	63.5	5000	34	5.2	C2A	—	BCH00119	—	—
21	533.4	4 ¹ / ₂	114.3	5039	17	2.7	C2A	—	—	BCH00156	—
21	533.4	6	152.4	5600	14	2.2	T3	—	—	BCH00157	—
21 ¹ / ₂	546.1	3 ¹ / ₂	88.9	3000	13	2.0	T3	—	—	BCH00158	—
26	660.4	5	127.0	6800	17	2.6	C2A	—	—	BCH00159	—
28	711.2	4 ¹ / ₂	114.3	6600	17	2.6	T3	—	—	BCH00160	—
28	711.2	5	127.0	5750	13	2.0	T3	—	—	BCH00161	—
32 ¹ / ₂	825.5	3 ¹ / ₂	88.9	3000	8	1.3	C2A	—	—	BCH00162	—

Ordering Information

Standard Heaters

Select a Ceramic Insulated Band Heater from pages 1-63 through 1-65. Each heater's Termination Type is indicated.

Type L1 has 10" long leads.

Type W1 has 12" long leads with 10" wire braid.

Type R2A has 12" long leads with 10" galvanized steel armor cable.

Custom Engineered/Manufactured Heaters

Understanding that an electric heater can be very application specific, for sizes and ratings not listed **TEMPCO** will design and manufacture a Ceramic Insulated Band Heater to meet your requirements. **Standard lead time is 3 weeks.**

Please Specify the following:

- Inside Diameter
- Width
- Wattage
- Voltage
- Termination (see pages 1-68 through 1-74)
- Lead Cable/Braid Length
- Construction style (see page 1-66)
- Clamping variation (see page 1-67)

⚠ WARNING: Cancer and Reproductive Harm - www.P65Warnings.ca.gov.

How To Specify A Ceramic Band Heater

Ceramic band heaters offer several variations in construction, clamping and electrical terminations. For ease of ordering, make a selection from options listed in each of the boxes below.

Construction Styles

(See below)
One-piece
Two-piece
Multiple Sections
(Specify number of sections required.)

Clamping

(See page 1-67)
Type B – Built-in bracket (Standard)
Type S – Built-in bracket with spring loaded screw
Type L – Latch and trunnion
Type F – Bent-up flange (Ears)

Termination

Select termination type from pages 1-68 through 1-74

Insulation

(See below)
Standard 1/4" insulation (**S**)
Double 1/2" insulation (**D**)

Shell Overlap

(See page 1-67)
Provides T/C hole. (Specify if required.)

Ceramic Band Construction Styles



One-Piece Band

The One-Piece Ceramic Band Heater is the basic design most often specified by OEMs and processors. It is available with all types of insulation, construction styles, clamping or termination variations.

Min. ID: 2" (50.8 mm)
Min. Width: 1" (25.4 mm)
Max. ID: 21" (533.4 mm)

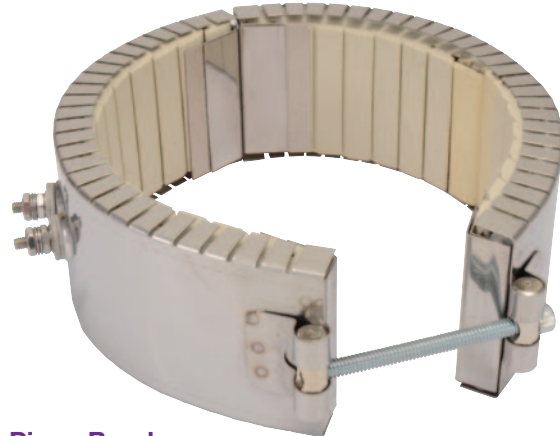

Two-Piece Band

The Two-Piece Ceramic Band Heater is commonly used on sizes larger than 21" diameter or when it would be inconvenient to use a one-piece heater. It is available with all types of insulation, construction styles, clamping or termination variations.

Min. ID: 4" (101.6 mm)
Min. Width: 1" (25.4 mm)
Max. ID: 44" (1118 mm)

Larger sizes are manufactured in multiple sections. Watts and volts are specified per each section when ordering.

Ceramic Band Insulation Options

Standard Insulation (S): 1/4"

Built-In ceramic fiber insulation 1/4" thick standard on all Ceramic Bands will reduce power consumption by 25 to 30 percent, and lower external temperatures.

Optional Double Insulation (D): 1/2"

For situations requiring additional insulation for lower external temperatures and increased electrical energy savings, Tempco offers Double Insulated Ceramic Bands with a full 1/2" thick ceramic fiber insulation. This will decrease power consumption by 35 to 37 percent when compared to uninsulated band heaters.



Standard Insulation
Cross Section



Double Insulation
Cross Section

Ceramic Band Clamping Variations



Type B – Built-In Bracket (Standard)

The Built-In Bracket is the basic design most often specified by OEMs and processors. The standard screw used is 1/4-20. It is available with all types of insulation, construction styles, and termination variations.

Type S – Built-In Bracket with Spring-Loaded Screw

The Built-In Bracket can also be supplied with a spring-loaded screw. The spring-loaded clamp aids in absorbing thermal expansion.

Limitations – One-Piece Bands

Min. ID: 2" (50.8 mm)
Min. Width: 1" (25.4 mm)

Limitations – Two-Piece Bands

Min. ID: 4" (101.6 mm)
Min. Width: 1" (25.4 mm)

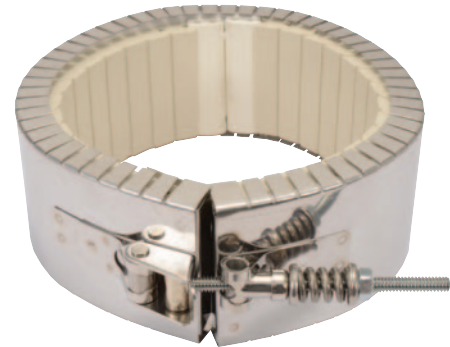

Type L – Latch and Trunnion

The spring-loaded Latch and Trunnion clamping system is ideal for bands over 12" in diameter to absorb thermal expansion and facilitate installation on large bands.

The Latch and Trunnion clamping system is available with all types of insulation, construction styles, and termination variations.

Limitations – One-Piece Bands

Min. ID: 4" (101.6 mm)
Min. Width: 1" (25.4 mm)

Limitations – Two-Piece Bands

Min. ID: 4" (101.6 mm)
Min. Width: 2" (50.8 mm)

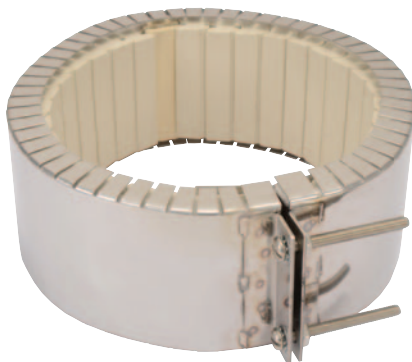

Type F – Bent-Up Flange (Ears)

The Bent-Up Flange (Ears) design is available with all types of insulation, construction styles, and termination variations.

Limitations – One-Piece Bands

Min. ID: 2" (50.8 mm)
Min. Width: 1" (25.4 mm)

Limitations – Two-Piece Bands

Min. ID: 4" (101.6 mm)
Min. Width: 2.5" (63.5 mm)

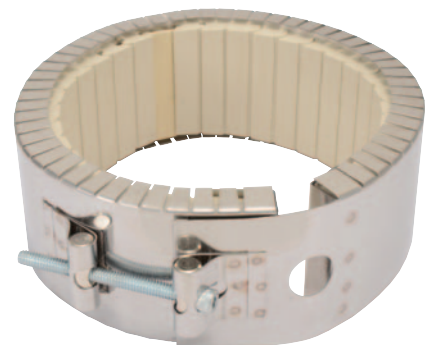

Shell Overlap

The Shell Overlap design is the preferred method of providing a thermocouple mounting hole in a ceramic band heater. It is available with all types of insulation, construction styles, clamping and termination variations.

Limitations – One-Piece Bands

Min. ID: 3" (76.2 mm)
Min. Width: 1-1/2" (38.1 mm)
Standard Hole: 3/4" (19.1 mm)

Limitations – Two-Piece Bands

Min. ID: 4" (101.6 mm)
Min. Width: 2" (50.8 mm)
Standard Hole: 3/4" (19.1 mm)

Terminations

Ceramic Band Type T2 – Screw Terminals

Type T2 Screw Terminals are available with all types of insulation, construction styles, and clamping variations. They are considered to be standard on most band heaters under 2" in width unless otherwise specified. 10-32 post terminals are standard.



One-Piece Band

Standard Termination Location:
opposite the gap; center of width

- * **Minimum Inside Diameter:** 2" (50.8 mm)
- * **Minimum Width:** 1" (25.4 mm)
- * **Maximum Volts/Amps:** 480VAC/25A

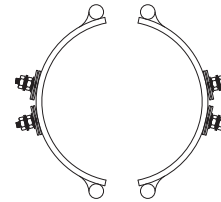

Two-Piece Band

Standard Termination Location:
center of each half; center of width

- * **Minimum Inside Diameter:** 4" (101.6 mm)
- * **Minimum Width:** 1" (25.4 mm)
- * **Maximum Volts/Amps:** 480VAC/25A each half

Ceramic Band Type T3 – Screw Terminals

Type T3 Screw Terminals are available with all types of insulation, construction styles, and clamping variations. They are considered to be standard on most band heaters unless otherwise specified. For use with leads, crimp terminals, or bus bars.



One-Piece Band

Standard Termination Location:
opposite the gap; across center of width

- * **Minimum Inside Diameter:** 2" (50.8 mm)
- * **Minimum Width:** 2" (50.8 mm)
- * **Maximum Volts/Amps:** 480VAC/25A

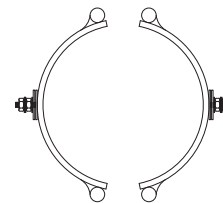

Two-Piece Band

Standard Termination Location:
center of each half; across center of width

- * **Minimum Inside Diameter:** 4" (101.6 mm)
- * **Minimum Width:** 2" (50.8 mm)
- * **Maximum Volts/Amps:** 480VAC/25A each half

Optional Igloo™ Ceramic Covers for Heaters with Screw Terminals

Igloo™ Ceramic Terminal Covers consist of two individual ceramic parts. They are available with all types of insulation, construction styles, and clamping variations. Unlike conventional ceramic caps, Igloo fully insulates any standard #10 terminal lugs used for electrical hook-ups.

Limitations

Min. ID: 2" (50.8 mm); **Min. Width:** 1" (25.4 mm)

Three types of Igloo™ bases are available:

Type C6 – Double Port In-Line P/N CER-101-104

Type C7 – Double Port 90° P/N CER-101-106

Type C8 – Single Port P/N CER-101-107

Igloo™ caps are available in the following screw terminal size:

10-32 – P/N CER-102-101

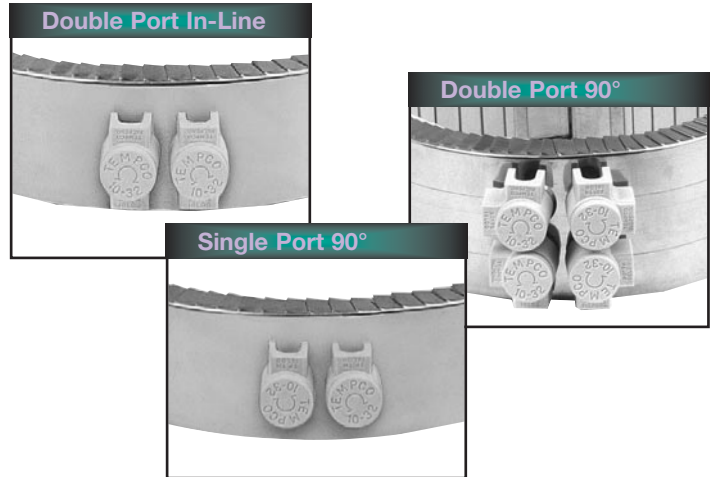

Exposed electrical wiring on band heater installations is a violation of Electrical Safety Codes including O.S.H.A.

Ceramic Band Type L1 – Straight Lead Wires

Type L1 Straight Lead Wires are available with all types of insulation, construction styles, and clamping variations. They are used primarily on small diameter bands where clearance is limited. If applicable, screw terminals should always be specified due to the high heat generated by ceramic bands. The standard flexible leads are 10" long.

If longer leads are required, specify when ordering.

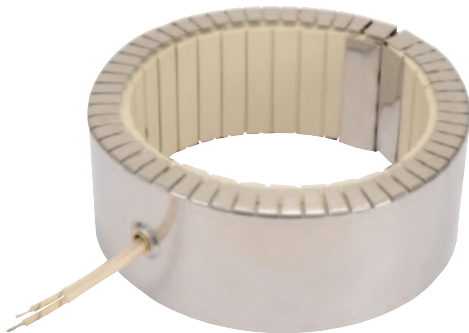

One-Piece Band

Standard Termination Location:
opposite the gap; center of width

- * **Minimum Inside Diameter:** 2" (50.8 mm)
- * **Minimum Width:** 1" (25.4 mm)
- * **Maximum Volts/Amps:** 480VAC/10A

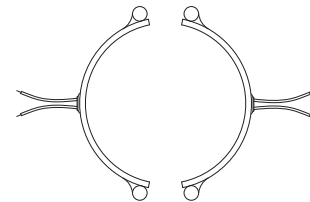

Two-Piece Band

Standard Termination Location:
center of each half; center of width

- * **Minimum Inside Diameter:** 4" (101.6 mm)
- * **Minimum Width:** 1" (25.4 mm)
- * **Maximum Volts/Amps:** 480VAC/10A each half

Terminations

Ceramic Band Type W1 – Abrasion Resistant Straight Wire Braid Leads

Straight Wire Braid Leads are available with all types of insulation, construction styles, and clamping variations. Wire braid leads offer sharp bending not possible with armor cable. If applicable, screw terminals should always be specified due to the high heat generated by ceramic bands. The standard leads are 10" of wire braid over 12" of flexible leads.

If longer leads are required, specify when ordering.



One-Piece Band

Standard Termination Location:
opposite the gap; center of width

- * **Minimum Inside Diameter:** 2" (50.8 mm)
- * **Minimum Width:** 1" (25.4 mm)
- * **Maximum Volts/Amps:** 480VAC/10A

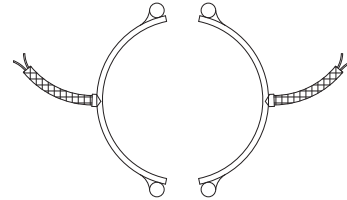

Two-Piece Band

Standard Termination Location:
center of each half; center of width

- * **Minimum Inside Diameter:** 4" (101.6 mm)
- * **Minimum Width:** 1" (25.4 mm)
- * **Maximum Volts/Amps:** 480VAC/10A each half

Ceramic Band Type R1 – Abrasion Resistant Straight Armor Cable

Straight Armor Cable is available with all types of insulation, construction styles, and clamping variations. Armor cable provides far superior protection to lead wires where abrasion is a constant problem. If applicable, screw terminals should always be specified due to the high heat generated by ceramic bands. The standard leads are 10" of armor cable over 12" of flexible leads.

If longer leads or electrical connectors are required, specify when ordering.

Type R1A – Galvanized Steel Armor Cable

Type R1B – Stainless Steel Armor Cable

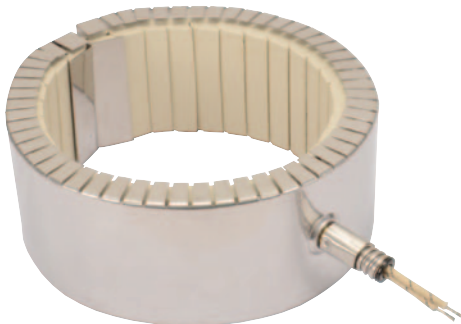

One-Piece Band

Standard Termination Location:
opposite the gap; center of width

- * **Minimum Inside Diameter:** 2" (50.8 mm)
- * **Minimum Width:** 1" (25.4 mm)
- * **Maximum Volts/Amps:** 480VAC/10A

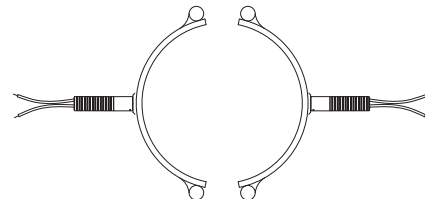

Two-Piece Band

Standard Termination Location:
center of each half; center of width

- * **Minimum Inside Diameter:** 4" (101.6 mm)
- * **Minimum Width:** 1" (25.4 mm)
- * **Maximum Volts/Amps:** 480VAC/10A each half

Ceramic Band Type R2 – Abrasion Resistant Right-Angle Armor Cable

Right-Angle Armor Cable is available with all types of insulation, construction styles, and clamping variations. It is used where space is limited and abrasion is a constant problem. If applicable, screw terminals should always be specified due to the high heat generated by ceramic bands. The standard leads are 10" of armor cable over 12" of flexible leads.

If longer leads or electrical connectors are required, specify when ordering.

Type R2A – Galvanized Steel Armor Cable

Type R2B – Stainless Steel Armor Cable

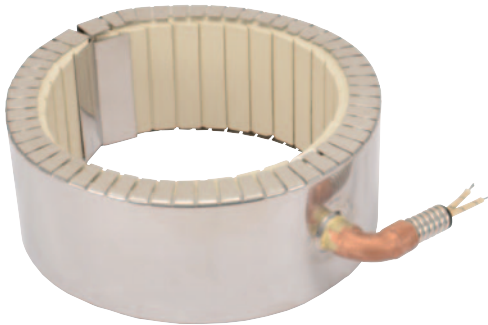

One-Piece Band

Standard Termination Location:
opposite the gap; center of width

- * **Minimum Inside Diameter:** 2" (50.8 mm)
- * **Minimum Width:** 1" (25.4 mm)
- * **Maximum Volts/Amps:** 480VAC/10A

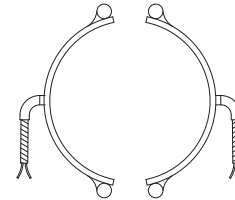

Two-Piece Band

Standard Termination Location:
center of each half; center of width

- * **Minimum Inside Diameter:** 4" (101.6 mm)
- * **Minimum Width:** 1" (25.4 mm)
- * **Maximum Volts/Amps:** 480VAC/10A each half

Ceramic Band Type S1 – Lead Wire Spring Strain Relief

A strain relief spring is attached to the heater at the termination exit to reduce strain on leads subjected to excessive flexing. The spring is 2-5/8" long. The flexible standard leads are 10" long with 2-1/2" of fiberglass sleeving.

If longer leads are required, specify when ordering.

Type S1A – Plain Leads and Strain Relief Spring

Type S1B – Stainless Steel Wire Braided Leads and Strain Relief Spring

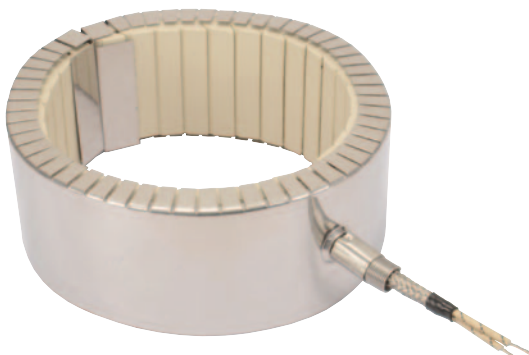

One-Piece Band

Standard Termination Location:
opposite the gap; center of width

- * **Minimum Inside Diameter:** 2" (50.8 mm)
- * **Minimum Width:** 1" (25.4 mm)
- * **Maximum Volts/Amps:** 480VAC/10A

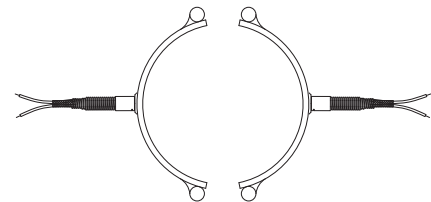

Two-Piece Band

Standard Termination Location:
center of each half; center of width

- * **Minimum Inside Diameter:** 4" (101.6 mm)
- * **Minimum Width:** 1" (25.4 mm)
- * **Maximum Volts/Amps:** 480VAC/10A each half

Terminations

General Purpose Terminal Boxes: Type C2 & Type C5

Terminal Boxes are available with all types of insulation, construction styles, or clamping variations. It is a simple and economical way to protect employees from electric shock or prevent electric shorts that can result from exposed wiring on band heater electrical installations.

The Heavy Duty Terminal Boxes have a 1/2" trade size knockout (actual diameter 7/8") that will accept standard armor cable connectors. The boxes can be field assembled on band heaters that have a center distance between screws of 7/8". To simplify installation the boxes can be pre-wired with galvanized armor, stainless steel armor, or wire braid.

Ceramic Band Type C2 – Standard Terminal Box

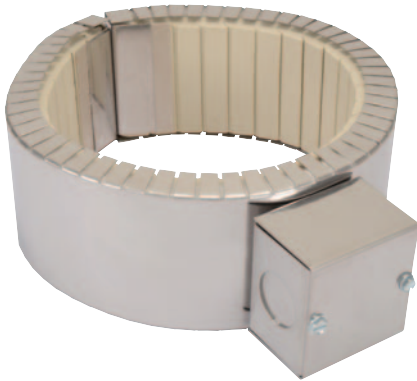

One-Piece Band

Standard Termination Location:
opposite the gap; center of width

- * **Minimum Inside Diameter:** 2" (50.8 mm)
- * **Minimum Width:** 1-1/2" (38.1 mm)
- * **Maximum Volts/Amps:** 480VAC/25A

Type C2 □ Standard Box

- C2A**—Box only
- C2B**—with galvanized armor
- C2C**—with stainless steel armor
- C2D**—with wire braid

Box Size: 1-1/2"H × 1-1/2"W × 2-1/2"L
for bands 1-1/2" to 2" wide

Box Size: 1-1/2"H × 2-1/8"W × 2-1/8"L
for bands greater than 2" wide

NOTE: Heater dimensions will determine terminal configuration.

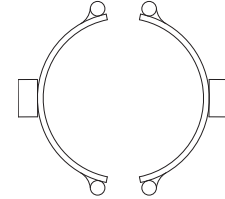

Two-Piece Band

Standard Termination Location:
center of each half; center of width

- * **Minimum Inside Diameter:** 4" (101.6 mm)
- * **Minimum Width:** 1-1/2" (38.1 mm)
- * **Maximum Volts/Amps:** 480VAC/25A each half

Ceramic Band Type C5 – Low-Profile Terminal Box

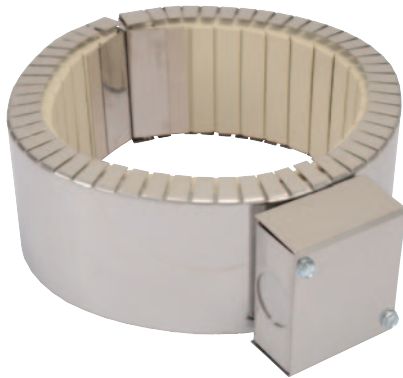

One-Piece Band

Standard Termination Location:
opposite the gap; center of width

- * **Minimum Inside Diameter:** 2" (50.8 mm)
- * **Minimum Width:** 1-1/2" (38.1 mm)
- * **Maximum Volts/Amps:** 480VAC/25A



Note: If a Low Profile Box with cable or leads is required, it is strongly recommended to order it pre-wired by the factory.

Type C5 □ Low Profile Box

- C5A**—Box only
- C5B**—with galvanized armor
- C5C**—with stainless steel armor
- C5D**—with wire braid
- C5J**—Box with lead wire

Box Size: 1"H × 1-1/4"W × 3"L
for bands 1-1/2" to 2" wide

Box Size : 1"H × 2-1/4"W × 2"L
for bands greater than 2" wide

NOTE: Heater dimensions will determine terminal configuration.

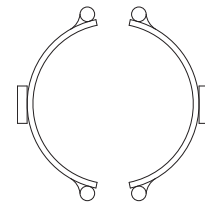

Two-Piece Band

Standard Termination Location:
center of each half; center of width

- * **Minimum Inside Diameter:** 4" (101.6 mm)
- * **Minimum Width:** 1-1/2" (38.1 mm)
- * **Maximum Volts/Amps:** 480VAC/25A each half

Exposed electrical wiring on band heater installations is a violation of Electrical Safety Codes including O.S.H.A.

Quick Disconnect Plugs: Type P1, Type P2, Type P3 & Type P4

Quick Disconnect Plugs are available on any construction or clamping variation. These quick disconnect plug assemblies are highly recommended and should be used whenever possible. The combination of plug and cup assembly along with armor cable covered leads eliminates all live exposed terminals or wiring that can be a potential hazard to employees or machinery.

Type P1 and P3 assemblies are available with a straight or right-angle plug. Type P2 and P4 plug assemblies have a lower profile and are available with a straight plug only.

To simplify installation, band heaters with these assemblies can be supplied pre-wired using high temperature lead wire protected with armor cable. *If longer leads are required, specify when ordering.*

Ceramic Band Type P1 – High Temperature Quick Disconnect Plugs



Type P1Q shown

Type P1 ☐ – Standard Cup Assembly

- P1K**—Cup Assembly only
- P1L**—w/straight plug only
- P1M**—w/90° plug only
- P1N**—w/straight plug & galvanized armor cable
- P1O**—w/straight plug & stainless steel armor cable
- P1P**—w/straight plug & wire braid
- P1Q**—w/90° plug & galvanized armor cable
- P1R**—w/90° plug & stainless steel armor cable
- P1S**—w/90° plug & wire braid

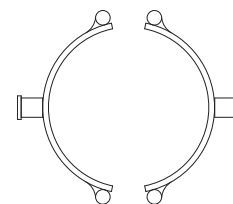

One-Piece Band

Standard Termination Location:
opposite the gap; center of width

- * **Minimum Inside Diameter:** 2" (50.8 mm)
- * **Minimum Width:** 2" (50.8 mm)
depending on termination orientation

Plug Electrical Ratings

- * **2-Pole 3-Wire Grounding**
- * **Maximum Volts:** 250 VAC
- * **Maximum Amps:** 16A
- * **Maximum Temperature:**
572°F (300°C)

Two-Piece Band

Standard Termination Location:
center of each half; center of width

- * **Minimum Inside Diameter:** 4" (101.6 mm)
- * **Minimum Width:** 2" (50.8 mm)
depending on termination orientation

Ceramic Band Type P2 – High Temperature Quick Disconnect Plugs



Type P2H shown

Type P2 ☐ – Low Profile Assembly

- P2F**—Low profile assembly only
- P2G**—w/straight plug only
- P2H**—w/straight plug and galvanized armor cable
- P2J**—w/straight plug and stainless steel armor cable
- P2K**—w/straight plug and wire braid

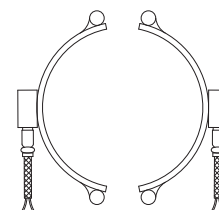

One-Piece Band

Standard Termination Location:
opposite the gap; center of width

- * **Minimum Inside Diameter:** 2" (50.8 mm)
- * **Minimum Width:** 2" (50.8 mm)

Plug Electrical Ratings

- * **2-Pole 3-Wire Grounding**
- * **Maximum Volts:** 250 VAC
- * **Maximum Amps:** 16A
- * **Maximum Temperature:**
572°F (300°C)

Two-Piece Band

Standard Termination Location:
center of each half; center of width

- * **Minimum Inside Diameter:** 4" (101.6 mm)
- * **Minimum Width:** 2" (50.8 mm)

CONTINUED

Terminations

Ceramic Band Type P3 – DIN 49458 A/B Quick Disconnect Plugs

Continued from previous page...



One-Piece Band

Standard Termination Location:
opposite the gap; center of width

- * **Minimum Inside Diameter:** 3" (76.2 mm)
- * **Minimum Width:** 2" (50.8 mm)

Type P3□—Vertical Box Assembly

- P3A**—Box assembly only
- P3B**—Box assembly w/straight plug
- P3C**—Box assembly w/right-angle plug

Plug Electrical Ratings

- * **2-Pole 3-Wire Grounding**
- * **Maximum Volts:** 250 VAC
- * **Maximum Amps:** 16A
- * **Maximum Temperature:** 392°F (200°C)

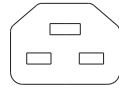

Standard Pin Orientation

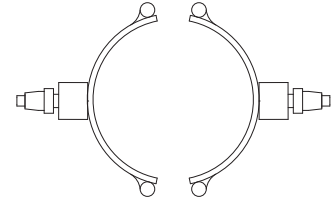

Two-Piece Band

Standard Termination Location:
center of each half; center of width

- * **Minimum Inside Diameter:** 4" (101.6 mm)
- * **Minimum Width:** 2" (50.8 mm)

Ceramic Band Type P4 – DIN 49458 A/B Quick Disconnect Plugs



One-Piece Band

Standard Termination Location:
opposite the gap; center of width

- * **Minimum Inside Diameter:** 2-1/2" (63.5 mm)
- * **Minimum Width:** 2-1/2" (63.5 mm)

Type P4□—Horizontal Box Assembly

- P4A**—Box assembly only
- P4B**—Box assembly w/straight plug

Plug Electrical Ratings

- * **2-Pole 3-Wire Grounding**
- * **Maximum Volts:** 250 VAC
- * **Maximum Amps:** 16A
- * **Maximum Temperature:** 392°F (200°C)



Standard Pin Orientation

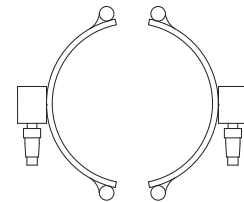

Two-Piece Band

Standard Termination Location:
center of each half; center of width

- * **Minimum Inside Diameter:** 4" (101.6 mm)
- * **Minimum Width:** 2-1/2" (63.5 mm)

Ceramic Band Heaters — Cool TO-THE Touch Shroud Systems

Type R Uninsulated Ceramic Band Heaters

This system was developed to provide another means of heating and cooling high temperature extrusion processes. Typically cast-in bronze or brass units are used in applications in which heater temperatures can be in excess of 700°F (371°C). Cast-in bronze or brass heaters are expensive and since they weigh approximately three times their aluminum counterparts they are difficult to install.

In response to this challenge, Tempco's engineers have developed a low mass, non-thermally insulated ceramic band heater to work in tandem with a highly efficient stainless steel sheet metal shroud for high temperature heating and cooling extrusion processes.

Forced air blowers are used for cooling. The ambient air-flow enters the shroud, circulates around the ceramic heater and barrel, removes the heat from the heater and the process and exits the shroud opposite the entrance port.

Construction Characteristics

Type R construction is an uninsulated ceramic band heater with a perforated Stainless Steel outer shell for more efficient cooling. It is typically used in multiple quantities with forced air cooling systems.

Consult Tempco with your requirements.

Type R Ceramic Insulated Band Heater



Cool TO-THE Touch™ Shroud System with Type RCC



Type RCC (Ribcage) Heating Mounting Configuration

Tempco's **Type RCC** (Rib Cage) Air Cooled System uses multiple Type R Ceramic Band Heaters under one air cooled shroud. Type R heaters are typically arranged with spaces between the heaters to enhance the cooling of the barrel when external heat is no longer required.

The Cool TO-THE Touch dual layer shroud uses an inner stainless steel solid layer thermally isolated from the heater, providing a path for the forced cooling air. An outer Stainless Steel perforated layer provides optimal venting and heat dissipation while providing personnel safety.

See catalog page 3-29 for shroud assembly details.

**Complete Information on Shrouds Systems
can be found in Section 3, pages 3-26 through 3-47**

PERFORMANCE RATINGS FOR HEATER BAND

Maximum Watt Density: 50 W/in² (8 W/cm²)

Maximum Temperature: 900°F (482°C)

MECHANICAL

Standard Width Increments: 1/8" (3.2 cm)

Maximum Width: depends on ratio of diameter to width

Minimum Width: 1" (25.4 mm)

Standard Gap: 3/8" ±1/8" (9.5 ±3.2 mm)

ELECTRICAL RATINGS

Resistance tolerance: +10%, -5%

Wattage tolerance: +5%, -10%

Maximum Voltage: 480 single or 3-phase (when applicable)

Maximum Amperage: Screw Terminals: 25 Amps per circuit

Lead Wire: 10 Amps per circuit

Additional Features

Electrical VARIATIONS

Three-Phase — On very high wattage band heaters it would be advantageous to set up the wiring three-phase to reduce the current load across a single conductor. Three-phase wiring is available with all types of insulation, construction styles, and clamping variations.

Limitations

Minimum width: 3" (76.2 mm)

Dual Voltage — Band heaters can be designed using 3-wire series/parallel circuits for dual voltage applications. Whether the heater is run on the high or low voltage, the wattage will be the same. Dual Voltage wiring is available with all types of insulation, construction styles, or clamping variations.

Limitations

Minimum width: 2" (50.8 mm)

Single-Phase/Three-Phase — Ceramic Band Heaters can be designed with multiple circuits to operate single or three-phase.

Lead VARIATIONS

Electrical Plugs — Industry standard NEMA twist lock electrical connectors are available. The plugs can be attached to fiberglass leads, armor cable or wire braid. Electrical Plugs can be added to any termination variation. See Section 15 page 15-15.

Terminal Lugs — Various types of crimp terminals can be attached to the heater leads to make wiring into applications quick and easy. High temperature [1200°F (649°C)] ring terminals and nylon or PVC insulated terminals are available. Spade, ring, and right-angle or straight quick disconnect type terminals can be attached to the leads. See Section 15 page 15-18.

High Temperature Lead Wire — When required, high temperature lead wire can be used. The wire is insulated with mica tapes over the stranded nickel conductors and then treated fiberglass overbraided. See Section 15 page 15-2.

Maximum temperature: 450°C (842°F)

Ground Terminal or Lead — For those applications requiring a separate ground terminal or lead attached to the heater sheath. A Ground Terminal or Lead is available on any construction or termination variation.

Other VARIATIONS

Oversize Gap — The nominal gap is 3/8". If a larger gap is required for probes or thermocouples, specify when ordering.

Installation Accessories Available for Immediate Delivery

- * High Temperature Terminal Lugs
- * Igloo™ Ceramic Insulating Covers
- * UL Listed Plugs
- * High Temperature Lead Wire 842°F (450°C)
- * Armor Cable
- * Stainless Steel Braid
- * High Temperature Sleeving
- * High Temperature Mica Insulated Wiring Harnesses 842°F (450°C)
- * Thermocouples
- * Temperature Controllers
- * High Temperature Fiberglass Tape

All Items Available from Stock

▼ Installation ▼ RECOMMENDATIONS

1. Disconnect electric power to the machine and/or heaters prior to installing or replacing heaters.
2. Do not install heaters in areas where combustible gases, vapor or dust is present.
3. Reduce the number of narrow or two-piece bands used on the barrel. Ceramic bands are very flexible and can be made in large widths and one-piece construction for easy installation. This eliminates heat losses between narrow bands and sharply reduces costly installation labor.
4. Use a heater that closely matches the wattage requirements. This will decrease the frequency of cycling and temperature overshoot, thereby increasing the life of the heater.
5. When replacing any other type of non-insulated band heater with Tempco ceramic band heaters using standard or double insulation, you can decrease your total operating wattage by approximately 15 to 20 percent.
6. To prevent overheating and heater failure, adequate temperature controls should be installed. The thermocouples must be kept free of contaminants and checked for good response to temperature changes. A faulty thermocouple can cause the destruction of an entire heating zone due to overheating. Tempco offers a wide variety of temperature controls and thermocouples from stock for immediate delivery. Consult the index of this catalog for appropriate pages.
7. Make certain that all barrel surfaces are clean and free of contaminants. During operation, the band heaters and cylinder surface must be kept free of all contaminants that might liquefy under heat and find their way into the heater windings, carbonizing and becoming conductive. The smallest amount of contamination can cause electrical shorts, resulting in heater failure.
8. Position heater bands on the barrel.
9. Take up all the slack by tightening the outer housing until the serrated edges come firmly in direct contact with the cylinder. Do not overtighten to the point where the serrated edges begin to collapse and thrust outward. At this point you are compressing the ceramic insulation and decreasing its insulating value. Unlike all other types of band heaters, ceramic bands heat by radiation as well as conduction and they do not require the same clamping force that is essential with all other types of band heaters. The proper torque is approximately 8 ft/lbs.
10. For heaters with screw terminals, remove the top nut and flat washers from the power screw terminals. Do not remove or loosen the bottom nut on the power screw terminals.
11. All electrical wiring of heater bands should be done by a qualified electrician using proper, dry personal protective equipment.
12. Use only lead wire with high temperature insulation and proper gauge size. See page 15-2 in the accessories section.
13. When connecting power leads to screw terminals make certain that barrels of terminal lugs are not facing down toward the heater case, which will create a short circuit.
14. Ensure leads are not kinked or sharply bent around other obstructions.
15. Make sure the voltage input to the heater bands does not exceed the voltage rating that is stamped on the heater band
16. It is recommended that an amperage reading is taken for each heater to verify proper wiring. (Amps = Watts ÷ Volts).
17. Insulate all live electrical connections per applicable safety standards.
18. Install shrouds around the machine to meet applicable safety requirements.
19. Once installed, check surroundings to make sure that contaminants won't get on the heater while the unit is in operation. Accumulation of contaminants on heaters can cause premature heater failure.



It is imperative that upon start-up of new machines at customer facilities, all of the aforementioned parameters are double checked by qualified field service personnel.

Exposed electrical wiring on band heater installations is a violation of Electrical Safety Codes including O.S.H.A.

Band Heaters



Tubular Bands

Tubular Construction Barrel & Nozzle Band Heaters



Design Features

- * Contamination-Proof
- * Higher Watt Densities
- * Temperatures Up to 1000°F (540°C)
- * Rugged Durable Construction
- * Greater Reliability
- * Various Lead Terminations
- * Optional Monel® Shroud

Designed to Perform Under Adverse Conditions

Tempco Tubular Band Heater design stands apart from all other similar type band heaters. This band heater is capable of performing under the most adverse conditions. Highly recommended for heating applications where premature nozzle band heater burn-out on plastic injection molding machines is a constant problem due to contamination from plastic overflow or other contaminants. Proven to be very effective for processing Teflon® and high temperature engineering resins, providing long, trouble-free service.

Standard Specifications and Tolerances

of Tubular Band Heaters. If tighter tolerances are required consult Tempco.

PERFORMANCE RATINGS

Maximum Temperature: 1000°F (540°C)

Maximum Watt Density: 40 W/in² (7 W/cm²)

ELECTRICAL RATINGS

Resistance Tolerance: +10%, -5%

Wattage Tolerance: +5%, -10%

Maximum Volts: 277 Volts

Maximum Watts: Depends on diameter

Maximum Amps: 30 Amps

MECHANICAL

Minimum Width: 1-1/2" (38.1 mm)

Minimum Inside Diameter: 1-1/2" (38.1 mm)

Standard Gap: 3/8"

Holes: Can be accommodated. Consult Tempco with your requirements.

Construction Characteristics

Incoloy® 840 sheath .315 diameter tubular heating elements are used as heat source. The tubular element is formed to the specified inside diameter to produce a snug slip-on fit.

A low thermal expansion alloy is used to make the strap that houses the tubular heating element. The strap edges are rolled over the element to prevent the strap from separating from the tubular heater. Specially designed mounting brackets are spot welded to the strap, providing the clamping force required to tightly draw the tubular heater against the cylinder.

Advantages and Variations

The straight section of the tubular heater is fully annealed, remaining ductile for field bending. Normally done to guide the leads away from machine obstructions.

If bending is required—

- Secure the tubular band heater to the cylinder in the position required.
- Draw the strap as tight as possible.
- Using a piece of 1/2" water pipe, insert the leads and tubular element into the pipe up to the point where you need the bend.

Proceed to bend with a generous radius.



DON'T MAKE A SHARP BEND AS YOU WILL CRACK THE HEATING ELEMENT.

Ordering Information

Standard — Select a Tubular Band heater from the table. All Tubular Band Heaters listed are supplied with Type W3 termination, 24" long.

Custom Engineered/Manufactured — An electric heater can be very application specific; for sizes and ratings not listed **TEMPCO** will design and manufacture a Tubular Band Heater to meet your requirements.

Standard lead time is 3 weeks.

Please Specify the following:

- | | | |
|--|--|--------------------------------|
| <input type="checkbox"/> Inside Diameter | <input type="checkbox"/> Lead Cable/Braid Length | <input type="checkbox"/> Width |
| <input type="checkbox"/> Voltage and Wattage | <input type="checkbox"/> Termination | |

⚠ WARNING: Cancer and Reproductive Harm - www.P65Warnings.ca.gov.

Standard (Non-Stock) Tubular Band Heaters

Tubular band heaters listed have Type W3 termination, 24" long.

ID in	Width in	Wattage	Watt Density	Part Number	
				120V	240V
1½	1	200	42	TNB01001	—
1½	1½	200	28	TNB01003	—
1½	2	300	31	TNB01005	—
1½	2½	300	25	TNB01007	—
1¾	1	200	36	TNB01009	—
1¾	1½	300	36	TNB01011	TNB01012
1¾	2	400	36	TNB01013	TNB01014
1¾	2½	400	29	TNB01015	TNB01016
2	1	250	39	TNB01017	TNB01018
2	1½	250	26	TNB01019	—
2	2	350	27	TNB01020	—
2	2½	450	28	TNB01021	—
2¼	1	250	35	TNB01022	TNB01023
2¼	1½	350	33	TNB01024	—
2¼	2	350	24	—	TNB01025
2¼	2½	450	25	—	TNB01026
2½	1	300	38	TNB01027	TNB01028
2½	1½	350	29	—	TNB01029
2½	1½	400	33	TNB01030	—
2½	1½	750	62	—	TNB01031
2½	2	450	28	—	TNB01032
2½	2½	450	22	—	TNB01033
2¾	1	300	34	TNB01034	TNB01035
2¾	1½	350	27	TNB01036	—
2¾	2	450	26	—	TNB01037
2¾	2½	600	27	—	TNB01038
3	1	300	31	TNB01039	TNB01040
3	1½	450	31	—	TNB01041
3	2	600	31	—	TNB01042
3	2½	600	25	—	TNB01043
3¼	1½	450	29	—	TNB01044
3¼	2	600	29	—	TNB01045
3¼	1½	300	18	—	TNB01046
3¼	3	700	21	—	TNB01047
3½	1½	200	38	TNB01048	—
3½	1¾	465	21	TNB01049	—
5	1½	600	25	—	TNB01050
5	2	600	19	TNB01051	—
5	2	2000	63	—	TNB01052
5	2¼	1150	32	—	TNB01053
5¼	2¼	900	24	—	TNB01054
5¼	3	300	6	—	TNB01055
5½	2	600	17	TNB01056	TNB01057
6	2	600	15	TNB01058	TNB01059

Type C3—Single Armor Cable Out Top

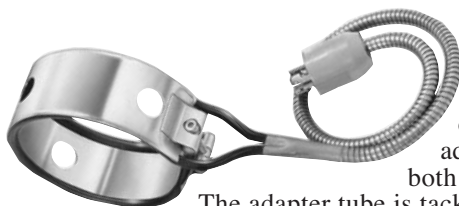

Armor Cable provides excellent protection against abrasion and contaminants. The cable exits through an adapter that encapsulates both tubular heater ends.

The adapter tube is tack welded to the heating element and the cable is crimped to the adapter for maximum security and seal protection. For maximum security and seal protection, 20" of cable and 24" flexible leads are standard.

Type C3A—Galvanized Armor Cable

Type C3B—Stainless Steel Armor Cable

Options:

- * Male or female plugs attached to leads. For plug selection, see Accessory Section, page 15-15.

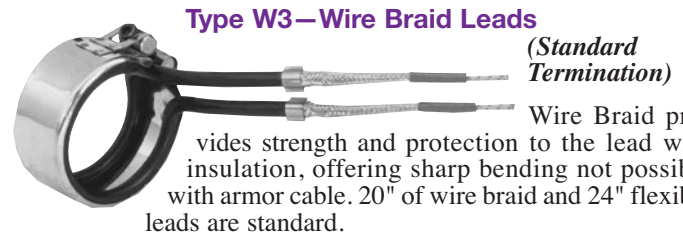

Type W3—Wire Braid Leads

(Standard Termination)

Wire Braid provides strength and protection to the lead wire insulation, offering sharp bending not possible with armor cable. 20" of wire braid and 24" flexible leads are standard.

Options:

- * Longer leads or braid
- * Male or female plugs attached to leads. For plug selection, see Accessory Section, page 15-15.

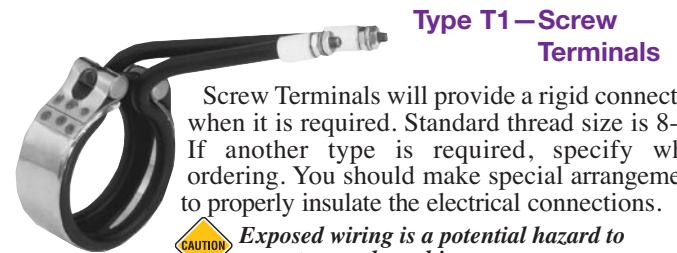

Type T1—Screw Terminals

Screw Terminals will provide a rigid connection when it is required. Standard thread size is 8-32. If another type is required, specify when ordering. You should make special arrangements to properly insulate the electrical connections.

CAUTION Exposed wiring is a potential hazard to operators and machine.

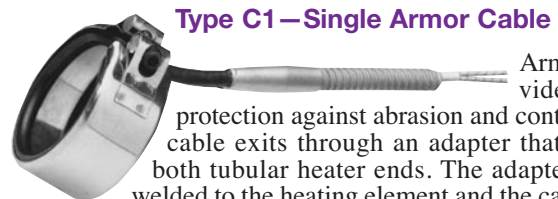

Type C1—Single Armor Cable

Armor Cable provides excellent protection against abrasion and contaminants. The cable exits through an adapter that encapsulates both tubular heater ends. The adapter tube is tack welded to the heating element and the cable is crimped to the adapter for maximum security and seal protection. 20" of cable and 24" flexible leads are standard.

Type C1A—Galvanized Armor Cable

Type C1B—Stainless Steel Armor Cable

Options:

- * Male or female plugs attached to leads. For plug selection, see Accessory Section, page 15-15.

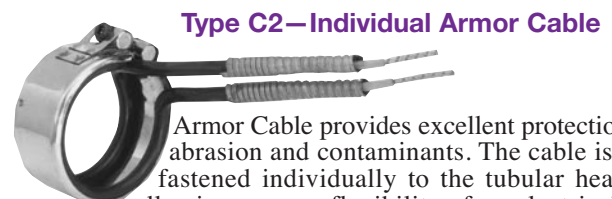

Type C2—Individual Armor Cable

Armor Cable provides excellent protection against abrasion and contaminants. The cable is securely fastened individually to the tubular heater ends, allowing more flexibility for electrical wiring connections. 20" of cable and 24" flexible leads are standard.

Type C2A—Galvanized Armor Cable

Type C2B—Stainless Steel Armor Cable

Maxiband®

The Most Sought After Band Heater

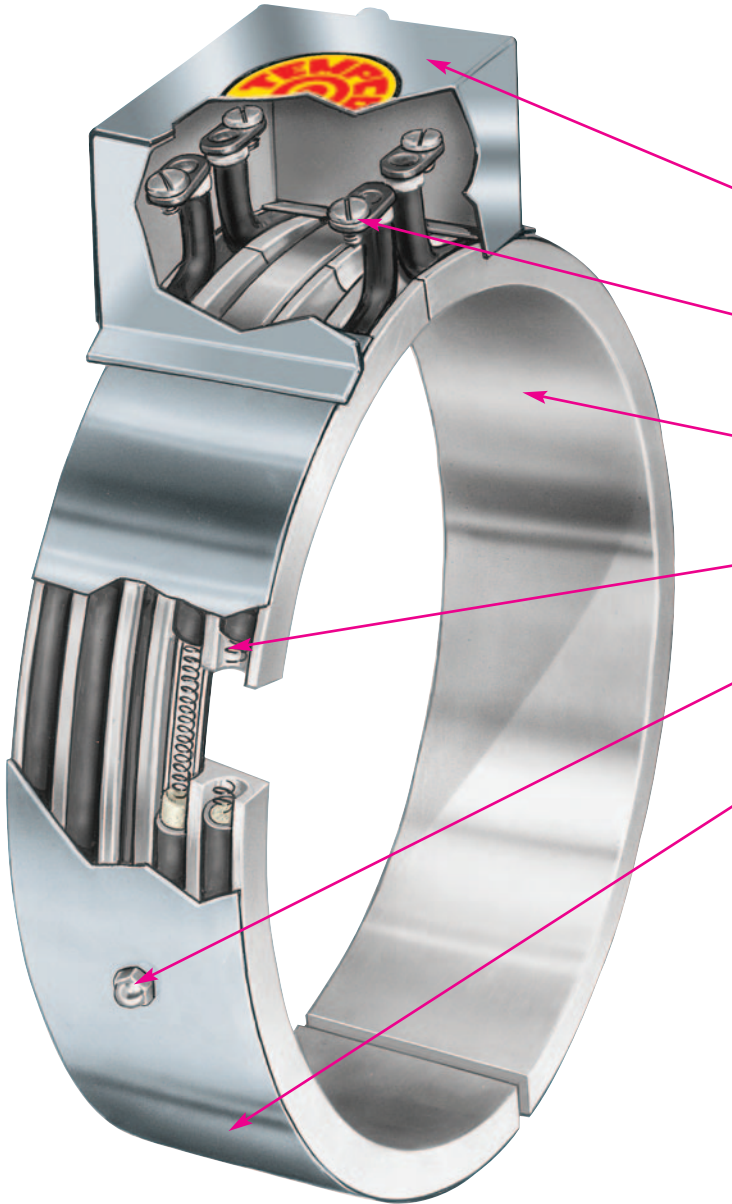

- A** General purpose terminal box offers excellent protection to the exposed terminals. To simplify electrical wiring, the box has two 1/2" trade size knockouts that will accept standard conduit or flexible armor cable connectors.
- B** Right-angle terminal lugs with 10-32 binding head screws provide ease of electrical wiring.
- C** The channels in the specially designed extruded aluminum track have been precisely sized to accept a .315 diameter tubular heating element, and provide an excellent heat sink for rapid heat transfer and good temperature uniformity.
- D** Ruggedly constructed .315 diameter tubular heating elements are the heat source for Maxiband Heaters, providing excellent life and long, trouble-free service.
- E** Crown nuts are located at 90° from the ends that fasten the clamping strap to the aluminum track, keeping the entire assembly together, providing ease of installation.
- F** The strap is made from a Low Thermal Expansion Alloy. It hinges at the terminal end to allow for easy installation. Specially designed mounting brackets with 1/4"-20 socket cap screws, located 180° from the terminal end, provide the clamping force required to tightly draw the heater assembly to the cylinder being heated.

MOUNTING BRACKETS

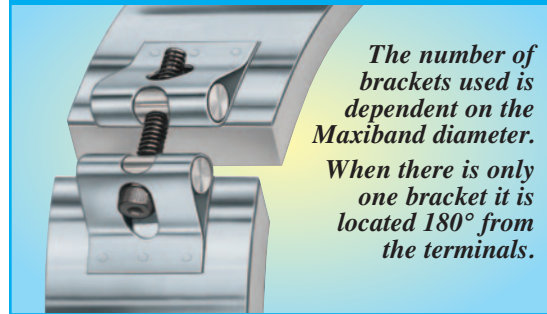

Typical Maxiband Clamping

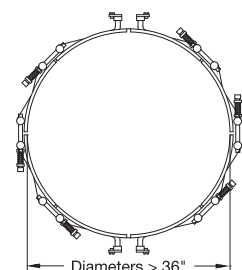
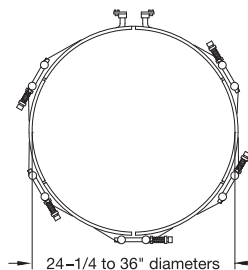
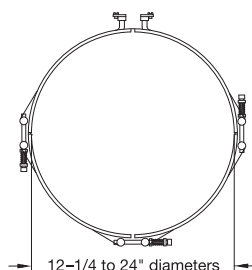
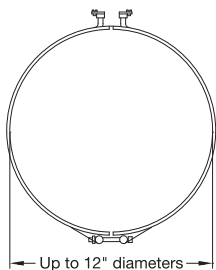



Maxiband® Heaters

Design Features

- * Quick Installation
- * Rugged, Durable Construction
- * Contamination Proof
- * Various Lead Terminations
- * Exceptionally Long Life
- * Excellent Heat Transfer
- * Excellent Temperature Uniformity

Heat and Liquid Cool Maxibands (MXB)

Stainless steel tubing for liquid cooling is placed in the additional channels of the aluminum track next to the tubular heater. The overall low mass construction and high thermal conductivity of the aluminum provides extremely uniform surface temperatures and rapid cooling cycles.

Cool Only Maxibands (MXC)

Stainless steel tubing for liquid cooling is placed in the aluminum track.

Construction Characteristics

Maxiband heaters are manufactured in five standard widths: 3/4", 1-1/2", 2-1/2", 3", and 4". They are available in a full range of standard diameters; construction variations for heating only, heat and cool, and cooling only; electrical ratings and a complete arrangement of various types of terminations to accommodate your specific application. For heating only standard sizes and ratings, see pages 1-82 through 1-86.

Maxiband MXB heaters, with heat and liquid cooling capabilities, incorporate stainless steel tubing placed in the additional channels of the aluminum track next to the tubular heater. The overall low mass construction and high thermal conductivity of the aluminum provides extremely uniform surface temperatures and rapid cooling cycles.

The low thermal expansion strap securely fastened to the aluminum track segments provides a built-in hinge, keeping both halves together at all times, making handling and installation easier. Specially designed integral mounting brackets are welded to the strap, providing the clamping force required to draw the heater assembly evenly and tightly to the cylinder.

PERFORMANCE RATINGS

Maximum Temperature: 650°F (350°C)

Nominal Watt Density: 35 W/in² (5.4 W/cm²)

ELECTRICAL RATINGS

Maximum Voltage: 277VAC per half

Maximum Wattage: Depends on diameter and number of elements used

Maximum Amperage: 30 amps per circuit

Resistance Tolerance: +10%, -5%

Wattage Tolerance: +5%, -10%

STANDARD GAP

Up to 11" ID—1/4" gap. As the diameter increases, the gap will also increase accordingly in order to accommodate the thermal expansion of the aluminum track.

HEATER THICKNESS — 1/2"

Designed for Durability and Trouble-Free Service

Tempco has been manufacturing Maxiband heaters since 1975. The Maxiband is a high quality, durable band heater providing more efficient heating and cooling as well as a longer life compared to other types of band heaters. Due to the rugged construction characteristics of this type of band heater, Maxiband has proven to be extremely valuable and has become the most sought after band heater of its type for plastic injection molding machines, extruders, and blow molding equipment. The initial cost is easily absorbed by the sharp reduction in downtime and labor costs involved in replacing burned-out, less efficient band heaters.

The straps are equipped with clamping brackets with 1/4"-20 socket head cap screws. On Maxibands exceeding 12" in diameter, spring-loaded screws provide the essential clamping force required in large diameter Maxibands to maintain positive contact with the cylinder being heated. On very large diameter Maxibands, the tubular element required becomes excessively long; therefore, two elements per half are used, each tubular element heating a 90° section of a Maxiband heater. In this case, two terminal boxes are required. A typical application for this type of Maxiband construction is heating the die heads of plastic blown film processing machines.

Maxiband heaters are constructed as sets. Each half consists of one tubular heating element and one aluminum track segment. The tubular heaters are always rated at half the total wattage of the set and full rated voltage. For better configuration on larger diameter cylinders, Maxibands exceeding 12" in diameter have the aluminum track segments in quadrants (see page 1-80 for details).

PHYSICAL SIZE CONSTRUCTION LIMITATIONS

Minimum Inside Diameter: 3-1/2" (Due to manufacturing constraints, some wattages/voltages may not be available in smaller heater sizes.)

Available Heater Widths

Maxiband Type	3/4"	1-1/2"	2-1/2"	3"	4"
Heating Only	•	•	•	•	•
Heat and Cool	N/A	N/A	•	•	•
Cooling Only	•	•	•	•	•

Cooling Tube Specifications

Heater Width	3/4"	1-1/2"	2-1/2"	3"	4"
Cooling Tube Diameter	3/8"	3/8"	3/8"	3/8"	3/8"
Cooling Tube Extension	4"	4"	4"	4"	4"
Cooling Tube Material	Stainless Steel				

Holes

Heater Width	3/4"	1-1/2"	2-1/2"	3"	4"
Maximum Size Hole	N/A	7/16"	7/16"	9/16"	9/16"

Hole is located in center of heater width; see page 8-17 for mounting hole location guidelines. For special hole arrangements, supply Tempco with a detailed drawing of your requirements.

Band Heaters



Standard Sizes and Ratings

Stock and Standard (Non-Stock) Maxibands (Heat Only) — 0.75 in (19.1 mm) Width

Stock Items Are Shown In RED

ID		Wattage	Watt Density		Part Number		
in	mm		W/in ²	W/cm ²	60V	120V	240V
3½	88.9	310	41	6.4	MXH00100	—	—
4	101.6	325	37	5.8	MXH00101	—	—
4½	114.3	370	38	5.8	MXH00102	—	—
5½	139.7	455	37	5.8	—	MXH00103	—
6	152.4	500	37	5.8	—	MXH00104	—
6¼	158.8	600	43	6.7	—	MXH00105	—
7	177.8	600	38	5.9	—	MXH00107	—
8	203.2	660	36	5.7	—	MXH00108	—
10	254.0	850	37	5.8	—	—	MXH00109
10½	266.7	900	38	5.8	—	—	MXH00110
12	304.8	700	25	3.9	—	—	MXH00111
13	330.2	1000	33	5.2	—	—	MXH00112
20	508.0	1570	34	5.2	—	—	MXH00113
22	558.8	1240	24	3.8	—	—	MXH00114
25	635.0	1450	25	3.9	—	—	MXH00115
28	711.2	1100	17	2.6	—	—	MXH00116
28	711.2	2100	32	5.0	—	—	MXH00117

Stock and Standard (Non-Stock) Maxibands (Heat Only) — 1.5 in (38.1 mm) Width

Stock Items Are Shown In RED

ID		Wattage	Watt Density		Part Number	
in	mm		W/in ²	W/cm ²	120V	240V
3½	88.9	300	22	3.4	MXH00643	—
3½	88.9	315	23	3.6	MXH01140	—
3½	88.9	475	35	5.5	MXH01141	MXH00121
3½	88.9	500	37	5.7	MXH01142	—
3½	88.9	550	41	6.3	MXH01143	—
3¾	95.3	600	41	6.3	MXH01144	MXH00124
3¾	95.3	700	48	7.4	MXH01145	—
4	101.6	550	35	5.4	—	MXH00126
4	101.6	625	39	6.1	—	MXH00127
4	101.6	700	44	6.8	—	MXH00128
4	101.6	750	47	7.3	—	MXH00129
4	101.6	875	55	8.6	—	MXH00130
4¼	108.0	675	40	6.1	—	MXH00131
4¼	108.0	780	46	7.1	—	MXH00132
4⅜	111.1	675	38	5.9	—	MXH00133
4⅞	112.7	725	40	6.3	—	MXH00134
4½	114.3	500	27	4.3	—	MXH00136
4½	114.3	600	33	5.1	—	MXH00137
4½	114.3	650	36	5.5	—	MXH00138
4½	114.3	725	40	6.2	—	MXH00139
4½	114.3	810	44	6.9	—	MXH00140
4½	114.3	850	47	7.2	—	MXH00141
4¾	120.7	650	34	5.2	—	MXH00142
4¾	120.7	750	39	6.0	—	MXH00143
5	127.0	580	28	4.4	—	MXH00144
5	127.0	800	39	6.0	—	MXH00145
5	127.0	925	45	7.0	—	MXH00146
5	127.0	1400	68	10.6	—	MXH00147

ID		Wattage	Watt Density		Part Number
in	mm		W/in ²	W/cm ²	240V
5⅞	130.2	800	38	5.9	MXH00148
5¼	133.4	600	28	4.3	MXH00149
5¼	133.4	970	45	6.9	MXH00150
5¼	133.4	975	45	7.0	MXH00151
5¼	133.4	1000	46	7.1	MXH00152
5½	139.7	875	38	5.9	MXH00153
5½	139.7	950	41	6.4	MXH00154
5½	139.7	1015	44	6.9	MXH00155
5¾	146.1	900	37	5.8	MXH00156
5¾	146.1	950	39	6.1	MXH00157
6	152.4	710	28	4.4	MXH00159
6	152.4	750	30	4.6	MXH00160
6	152.4	950	38	5.8	MXH00161
6	152.4	1100	44	6.7	MXH00162
6¼	158.8	1000	38	5.9	MXH00163
6½	165.1	500	18	2.8	MXH00164
6½	165.1	750	27	4.2	MXH00165
6½	165.1	900	33	5.0	MXH00166
6½	165.1	950	34	5.3	MXH00167
6½	165.1	1000	36	5.6	MXH00168
6½	165.1	1050	38	5.9	MXH00169
6½	165.1	1200	43	6.7	MXH00170
6⅞	169.8	1000	35	5.4	MXH00171
6¾	171.5	1125	39	6.1	MXH00172
7	177.8	500	17	2.6	MXH00173
7	177.8	850	28	4.4	MXH00174
7	177.8	1000	33	5.2	MXH00175



Note: Part Numbers shown are for Maxiband Heaters with type "S" termination. For details see page 1-87.

Stock and Standard (Non-Stock) Maxibands (Heat Only) — 1.5 in (38.1 mm) Width

Stock Items Are Shown In RED

ID		Wattage	Watt Density		Part Number 240V
in	mm		W/in ²	W/cm ²	
7	177.8	1100	37	5.7	MXH00176
7	177.8	1300	43	6.7	MXH00177
7¼	184.2	1175	38	5.8	MXH00178
7½	190.5	900	28	4.3	MXH00179
7½	190.5	1200	37	5.8	MXH00180
7¾	193.7	1200	36	5.6	MXH00181
7¾	196.9	1250	37	5.8	MXH00182
8	203.2	550	16	2.5	MXH00183
8	203.2	800	23	3.6	MXH00184
8	203.2	1100	32	4.9	MXH00185
8	203.2	1200	35	5.4	MXH00186
8	203.2	1300	37	5.8	MXH00187
8	203.2	1475	43	6.6	MXH00188
8½	215.9	1175	32	4.9	MXH00189
8½	215.9	1200	32	5.0	MXH00190
8½	215.9	1375	37	5.8	MXH00191
8½	215.9	1400	38	5.9	MXH00192
8½	215.9	1500	40	6.3	MXH00193
8¾	222.3	1000	26	4.1	MXH00194
8¾	222.3	1400	37	5.7	MXH00195
9	228.6	1100	28	4.3	MXH00196
9	228.6	1390	35	5.5	MXH00197
9	228.6	1475	37	5.8	MXH00198
9	228.6	1550	39	6.1	MXH00199
9	228.6	1675	43	6.6	MXH00200
9¼	235.0	1450	36	5.5	MXH00201
9¼	235.0	1500	37	5.7	MXH00202
9½	241.3	1300	31	4.8	MXH00203
9½	241.3	1325	32	4.9	MXH00204
9½	241.3	1550	37	5.8	MXH00205
9½	241.3	1765	42	6.5	MXH00206
9¾	247.7	1810	42	6.5	MXH00207
10	254.0	1150	26	4.0	MXH00208
10	254.0	1350	31	4.7	MXH00209
10	254.0	1625	37	5.7	MXH00210
10¼	260.4	1425	31	4.9	MXH00211
10½	266.7	1450	31	4.8	MXH00212
10½	266.7	1700	37	5.7	MXH00213
11	279.4	1000	20	3.2	MXH00214
11	279.4	1300	27	4.1	MXH00215
11	279.4	1500	31	4.8	MXH00216
11	279.4	1775	36	5.6	MXH00217
11	279.4	2000	41	6.3	MXH00218
11¼	285.8	1825	36	5.7	MXH00219
11¼	285.8	2075	41	6.4	MXH00220
11½	292.1	1875	37	5.7	MXH00221
11¾	295.3	1875	36	5.6	MXH00222
11¾	298.5	1000	19	3.0	MXH00223
12	304.8	840	16	2.4	MXH00224
12	304.8	1250	23	3.6	MXH00225
12	304.8	1400	26	4.1	MXH00226
12	304.8	1950	36	5.6	MXH00227

ID		Wattage	Watt Density		Part Number 240V
in	mm		W/in ²	W/cm ²	
12	304.8	2000	37	5.8	MXH00228
12	304.8	2500	47	7.2	MXH00229
12½	317.5	2100	38	5.8	MXH00230
12¾	323.9	2100	37	5.7	MXH00231
13	330.2	1400	24	3.7	MXH00232
13	330.2	1500	26	4.0	MXH00233
13	330.2	1525	26	4.1	MXH00234
13	330.2	1800	31	4.8	MXH00235
13	330.2	2150	37	5.7	MXH00236
13¾	349.3	2265	37	5.7	MXH00237
13¾	354.0	2125	34	5.3	MXH00238
14	355.6	1200	19	3.0	MXH00239
14	355.6	1600	25	3.9	MXH00240
14	355.6	2275	36	5.6	MXH00241
14	355.6	2500	40	6.2	MXH00242
14	355.6	2600	41	6.4	MXH00243
14½	368.3	3100	47	7.4	MXH00244
15	381.0	1000	15	2.3	MXH00245
15	381.0	1450	21	3.3	MXH00246
15	381.0	1600	24	3.7	MXH00247
15	381.0	2100	31	4.8	MXH00248
15	381.0	2500	37	5.7	MXH00249
15	381.0	2750	41	6.3	MXH00250
15	381.0	2800	41	6.4	MXH00251
15½	393.7	2200	31	4.9	MXH00252
15½	393.7	3000	43	6.6	MXH00253
15¾	400.1	2500	35	5.4	MXH00254
15¾	400.1	2600	37	5.7	MXH00255
16	406.4	2200	30	4.7	MXH00256
16	406.4	4000	55	8.6	MXH00257
16½	419.1	2700	36	5.6	MXH00258
17	431.8	2400	31	4.8	MXH00259
18	457.2	2960	36	5.6	MXH00260
19	482.6	2200	25	3.9	MXH00261
20	508.0	2350	26	4.0	MXH00262
20	508.0	4000	44	6.8	MXH00263
21	533.4	2450	26	4.0	MXH00264
21¼	539.8	3500	36	5.6	MXH00265
21½	546.1	3500	36	5.5	MXH00266
22	558.8	2500	25	3.8	MXH00267
22½	571.5	3600	35	5.4	MXH00268
23¾	593.7	3850	36	5.6	MXH00269
24	609.6	3500	32	4.9	MXH00270
24½	622.3	3000	27	4.1	MXH00271
26	660.4	3000	25	3.9	MXH00272
28	711.2	3300	26	4.0	MXH00273
28	711.2	4220	33	5.1	MXH00274
30	762.0	3500	25	3.9	MXH00275
31	787.4	2900	20	3.1	MXH00276
33	838.2	3600	24	3.7	MXH00277
34	863.6	4800	31	4.7	MXH00278
35	889.0	4500	28	4.3	MXH00279
36	914.4	4200	25	3.9	MXH00280
37	939.8	5000	29	4.5	MXH00281
39	990.6	4400	24	3.8	MXH00282
45	1143.0	9000	43	6.7	MXH00283



Note: Part Numbers shown are for Maxiband Heaters with type "S" termination. For details see page 1-87.

Ordering Information

See page 1-86

Standard Sizes and Ratings

Stock and Standard (Non-Stock) Maxibands (Heat Only) — 2.5 in (63.5 mm) Width

Stock Items Are Shown In RED

ID		Wattage	Watt Density		Part Number 120V
in	mm		W/in ²	W/cm ²	
3½	88.9	350	16	2.4	MXH00286
3½	88.9	650	29	4.5	MXH00287
3½	88.9	775	34	5.3	MXH00288

ID		Wattage	Watt Density		Part Number 240V
in	mm		W/in ²	W/cm ²	
3½	88.9	975	43	6.7	MXH00289
3½	88.9	1300	58	9.0	MXH00290
3¾	95.3	975	40	6.2	MXH00291
4	101.6	900	34	5.3	MXH00292
4	101.6	1050	40	6.2	MXH00293
4¼	108.0	1125	40	6.1	MXH00294
4½	114.3	1025	34	5.2	MXH00295
4½	114.3	1200	40	6.1	MXH00296
4½	114.3	1500	49	7.7	MXH00297
5	127.0	1150	34	5.2	MXH00298
5	127.0	1325	39	6.0	MXH00299
5	127.0	1500	44	6.8	MXH00300
5¼	133.4	1200	33	5.1	MXH00301
5¼	133.4	1400	39	6.0	MXH00302
5½	139.7	1250	33	5.1	MXH00303
5½	139.7	1475	39	6.0	MXH00304
5½	139.7	2000	52	8.1	MXH00305
5⅞	141.3	1100	28	4.4	MXH00306
6	152.4	800	19	2.9	MXH00307
6	152.4	1150	27	4.2	MXH00308
6	152.4	1375	33	5.1	MXH00309
6	152.4	1600	38	5.9	MXH00310
6½	165.1	1750	38	5.9	MXH00311
6½	165.1	1800	39	6.1	MXH00312
6¾	171.5	1300	27	4.2	MXH00313
6¾	174.6	1300	27	4.1	MXH00314
7	177.8	1870	37	5.8	MXH00315
7	177.8	1974	39	6.1	MXH00316
7¼	184.2	2500	48	7.5	MXH00317
7½	190.5	1140	21	3.3	MXH00318
7½	190.5	1725	32	5.0	MXH00319
7½	190.5	2025	38	5.8	MXH00320
7⅞	193.7	1875	34	5.3	MXH00321
7⅞	200.0	1500	26	4.1	MXH00322
8	203.2	1850	32	5.0	MXH00323
8	203.2	2150	37	5.8	MXH00324
8¼	209.6	1300	22	3.4	MXH00325
8¼	209.6	1900	32	4.9	MXH00326
8½	215.9	1975	32	5.0	MXH00327
8½	215.9	2300	37	5.8	MXH00328
8¾	222.3	2000	31	4.9	MXH00329
8¾	222.3	2025	32	4.9	MXH00330
9	228.6	2425	37	5.7	MXH00331
9¼	235.0	2150	32	4.9	MXH00332
9⅞	239.7	2200	32	4.9	MXH00333
9½	241.3	2100	30	4.7	MXH00334
9½	241.3	2375	34	5.3	MXH00335
9½	241.3	2575	37	5.7	MXH00336
9¾	247.7	2250	31	4.9	MXH00337
9¾	247.7	2625	37	5.7	MXH00338
9¾	250.8	1500	21	3.2	MXH00339
10	254.0	1350	18	2.8	MXH00340

ID		Wattage	Watt Density		Part Number 240V
in	mm		W/in ²	W/cm ²	
10	254.0	2325	32	4.9	MXH00341
10	254.0	2700	37	5.7	MXH00342
10¼	260.4	2375	31	4.9	MXH00343
10½	266.7	2850	37	5.7	MXH00344
11	279.4	2125	26	4.0	MXH00345
11	279.4	2550	31	4.9	MXH00346
11	279.4	2975	37	5.7	MXH00347
11⅞	290.5	3050	36	5.6	MXH00348
11½	292.1	3050	36	5.5	MXH00349
12	304.8	1875	21	3.3	MXH00350
12	304.8	2250	25	3.9	MXH00351
12	304.8	2800	31	4.9	MXH00352
12	304.8	3250	36	5.6	MXH00353
12⅞	309.5	3370	37	5.8	MXH00354
12½	317.5	1450	16	2.4	MXH00355
12½	317.5	3000	32	5.0	MXH00356
12½	317.5	3425	37	5.7	MXH00357
12⅞	319.1	1600	17	2.6	MXH00358
12⅞	320.7	2375	25	3.9	MXH00359
12⅞	320.7	3000	32	4.9	MXH00360
13	330.2	3200	33	5.1	MXH00361
13	330.2	3575	37	5.7	MXH00362
13	330.2	4300	44	6.9	MXH00363
13⅞	334.9	3275	33	5.1	MXH00364
13¾	342.9	3710	37	5.7	MXH00365
13¾	349.3	3775	37	5.7	MXH00366
14	355.6	1500	14	2.2	MXH00367
14	355.6	1900	18	2.8	MXH00368
14	355.6	2200	21	3.2	MXH00369
14	355.6	3000	29	4.4	MXH00370
14	355.6	3500	33	5.2	MXH00371
14	355.6	3850	37	5.7	MXH00372
14	355.6	5000	48	7.4	MXH00373
14⅞	379.4	2725	24	3.8	MXH00374
14⅞	379.4	3725	33	5.1	MXH00375
15	381.0	3540	31	4.9	MXH00376
15	381.0	4800	43	6.6	MXH00377
15⅞	385.7	2300	20	3.1	MXH00378
15⅞	404.8	3125	26	4.0	MXH00379
16	406.4	4000	33	5.1	MXH00380
16	406.4	5000	41	6.4	MXH00381
18	457.2	4250	31	4.8	MXH00382
18	457.2	4600	34	5.2	MXH00383
18	457.2	5200	38	5.9	MXH00384
19	482.6	5200	36	5.6	MXH00385
20	508.0	5000	33	5.1	MXH00386
20	508.0	5500	36	5.6	MXH00387
21	533.4	4950	31	4.8	MXH00388
21	533.4	7000	44	6.8	MXH00389
36	914.4	7000	25	3.9	MXH00390



Note: Part Numbers shown are for Maxiband Heaters with type "S" termination. For details see page 1-87.

Stock and Standard (Non-Stock) Maxibands (Heat Only) — 3 in (76.2 mm) Width

Stock Items Are Shown In RED

ID		Wattage	Watt Density		Part Number 240V
in	mm		W/in ²	W/cm ²	
3½	88.9	500	19	2.9	MXH00391
3½	88.9	600	22	3.4	MXH00392
4½	114.3	1500	41	6.4	MXH00393
5	127.0	1390	34	5.2	MXH00394
5	127.0	1800	44	6.8	MXH00395
5¼	133.4	1475	34	5.3	MXH00396
5½	139.7	1560	34	5.3	MXH00397
5¾	146.1	1625	34	5.2	MXH00398
6	152.4	1100	22	3.4	MXH00399
6	152.4	1500	30	4.6	MXH00400
6	152.4	1720	34	5.3	MXH00401
6¼	158.8	1770	33	5.2	MXH00402
6½	165.1	1820	33	5.1	MXH00403
6¾	171.5	1900	33	5.1	MXH00404
7	177.8	1200	20	3.1	MXH00405
7	177.8	2000	33	5.2	MXH00406
7¼	184.2	2050	33	5.1	MXH00407
7½	190.5	2120	33	5.1	MXH00408
7¾	196.9	2200	33	5.1	MXH00409
8	203.2	2270	33	5.1	MXH00410
8¼	209.6	1800	25	3.9	MXH00411
8¼	209.6	2325	32	5.0	MXH00412
8½	215.9	2410	33	5.0	MXH00413
8¾	222.3	2475	32	5.0	MXH00414
9	228.6	1800	23	3.5	MXH00415
9	228.6	2200	28	4.3	MXH00416
9	228.6	2300	29	4.5	MXH00417
9	228.6	2600	33	5.1	MXH00418
9	228.6	2700	34	5.3	MXH00419
9¼	235.0	2600	32	5.0	MXH00420
9½	241.3	2675	32	5.0	MXH00421
9¾	247.7	2750	32	5.0	MXH00422
10	254.0	2000	23	3.5	MXH00423
10	254.0	2820	32	5.0	MXH00424
10¼	260.4	2900	32	5.0	MXH00425
10½	266.7	2975	32	5.0	MXH00426

ID		Wattage	Watt Density		Part Number 240V
in	mm		W/in ²	W/cm ²	
10¼	273.1	3025	32	4.9	MXH00427
11	279.4	2000	20	3.2	MXH00428
11	279.4	3100	32	4.9	MXH00429
11¼	285.8	2500	25	3.9	MXH00430
11¼	285.8	3175	32	4.9	MXH00431
11½	292.1	2000	20	3.0	MXH00432
11½	292.1	2710	26	4.1	MXH00433
11½	292.1	3250	32	4.9	MXH00434
11¾	298.5	3325	32	4.9	MXH00435
12	304.8	2000	19	2.9	MXH00436
12	304.8	2830	26	4.1	MXH00437
12	304.8	3400	32	4.9	MXH00438
12¼	311.2	3475	32	4.9	MXH00439
12½	317.5	2400	21	3.3	MXH00440
12½	317.5	3000	27	4.2	MXH00441
12½	317.5	3525	32	4.9	MXH00442
12¾	323.9	3600	32	4.9	MXH00443
13	330.2	3670	31	4.9	MXH00444
13¼	336.6	3750	32	4.9	MXH00445
13½	342.9	3280	27	4.2	MXH00446
13½	342.9	3800	31	4.9	MXH00447
13¾	349.3	3870	31	4.9	MXH00448
14	355.6	3760	30	4.6	MXH00449
14	355.6	3950	31	4.9	MXH00450
15	381.0	3535	26	4.0	MXH00451
15½	393.7	4000	29	4.4	MXH00452
19	482.6	5400	31	4.8	MXH00453
19½	495.3	5500	31	4.8	MXH00454
22	558.8	8000	40	6.2	MXH00455
26	660.4	8000	33	5.2	MXH00456
29	736.6	9000	34	5.2	MXH00457
30	762.0	7500	27	4.2	MXH00458
30	762.0	9500	34	5.3	MXH00459



Note: Part Numbers shown are for Maxiband Heaters with type "S" termination. For details see page 1-87.

Ordering Information

See page 1-86

CONTINUED 

Band Heaters



Standard Sizes and Ratings

Standard (Non-Stock) Maxibands (Heat Only) — 4 in (101.6 mm) Width

Continued from previous page...

ID		Wattage	Watt Density		Part Number 240V
in	mm		W/in ²	W/cm ²	
5	127.0	1870	34	5.3	MXH00460
5¼	133.4	1970	34	5.3	MXH00461
5½	139.7	1025	17	2.6	MXH00462
5½	139.7	1800	29	4.6	MXH00463
5½	139.7	2075	34	5.3	MXH00464
5½	139.7	2500	41	6.3	MXH00465
5¾	146.1	2175	34	5.2	MXH00466
6	152.4	2285	34	5.3	MXH00467
6¼	158.8	2370	34	5.2	MXH00468
6½	165.1	2475	34	5.2	MXH00469
6¾	171.5	2575	34	5.2	MXH00470
7	177.8	2675	33	5.2	MXH00471
7¼	184.2	2750	33	5.1	MXH00472
7½	190.5	2845	33	5.1	MXH00473

ID		Wattage	Watt Density		Part Number 240V
in	mm		W/in ²	W/cm ²	
7¼	196.9	2950	33	5.1	MXH00474
8	203.2	2250	24	3.8	MXH00475
8	203.2	3050	33	5.1	MXH00476
8¼	209.6	3050	32	4.9	MXH00477
8½	215.9	3545	36	5.6	MXH00478
8¾	222.3	3350	33	5.1	MXH00479
9¼	235.0	3545	33	5.1	MXH00480
11¼	298.5	3000	21	3.3	MXH00481
14	355.6	5500	33	5.1	MXH00482
14¼	362.0	5150	30	4.7	MXH00483
15	381.0	6000	33	5.2	MXH00484
16½	419.1	6500	33	5.1	MXH00485
20	508.0	4000	16	2.5	MXH00486
20	508.0	5500	23	3.5	MXH00487



Note: Part Numbers shown are for Maxiband Heaters with type “S” termination. For details see page 1-87.

Ordering Information

Stock Heaters

Select a Stock Maxiband Heater (identified by a **RED** part number) from the Standard Sizes and Ratings Lists on Pages 1-82 through 1-86. Part Numbers shown are for Maxiband Heaters with type “S” termination.

Stock heaters can be modified to the following terminations:

Type **C**—Outlet terminal box

Type **P2**—Low profile high temp. quick disconnect

Type **W3**—Wire braid leads

Type **TS**—Contamination seal

A Part Number will be issued at time of order.

Custom Engineered/Manufactured Heaters

An electric heater can be very application specific; for sizes and ratings not listed **TEMPCO** will design and manufacture a Maxiband Heater to meet your requirements. **Standard lead time is 3 weeks.**

Please Specify the following:

- | | |
|--|---|
| <input type="checkbox"/> Inside Diameter | <input type="checkbox"/> Termination |
| <input type="checkbox"/> Width | <input type="checkbox"/> Construction |
| <input type="checkbox"/> Total Wattage | <input type="checkbox"/> Clamping |
| <input type="checkbox"/> Voltage per half | <input type="checkbox"/> Special Features |
| <input type="checkbox"/> Lead Cable/Braid Length | <input type="checkbox"/> Quantity |

⚠ WARNING: Cancer and Reproductive Harm - www.P65Warnings.ca.gov.

Maxiband Terminal Lug Termination



Type S—Standard Terminal Lugs

Terminal Lugs with 10-32 binding head screws.



Note: Standard on all Maxiband heaters unless otherwise specified.

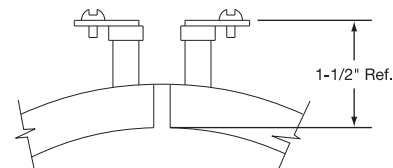

Abrasion Resistant Lead Terminations



Type W3—Wire Braid Leads

Stainless Steel Wire Braid provides strength and protection to the lead wire's insulation and offers sharp bending not possible with armor cable. The standard leads are 20" of wire braid over 24" of flexible leads.

If longer leads are required, specify when ordering.

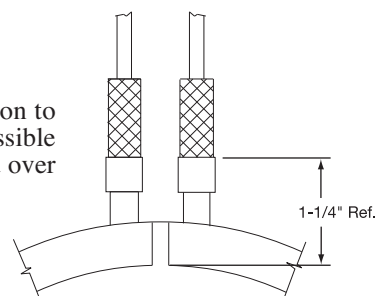

Type R1□—Armor Cable Leads

Armor Cable provides excellent protection against abrasion and contaminants. The cable exits through an adapter that encapsulates both elements' ends on each half. The adapter tube is tack welded to the heating element and the cable is crimped to the adapter for maximum security and seal protection. The standard leads are 20" of cable over 24" of flexible leads.

If longer leads are required, specify when ordering.

Type R1A — Galvanized Armor Cable
Type R1B — Stainless Steel Armor Cable

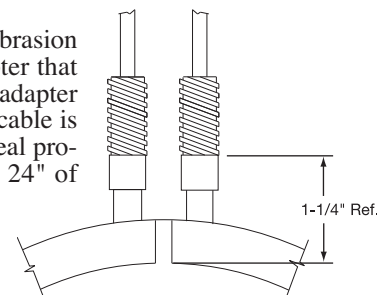

Type TS—Leads with Contamination Seal

Teflon® shrinkdown sleeving provides a good moisture and contamination seal. The sleeving is shrunk down on the element ends and is about 3-1/2" long. The maximum temperature allowed at the Teflon® seal sleeve is 500°F (260°C). The standard flexible leads are 24" in length.

If longer leads are required, specify when ordering.

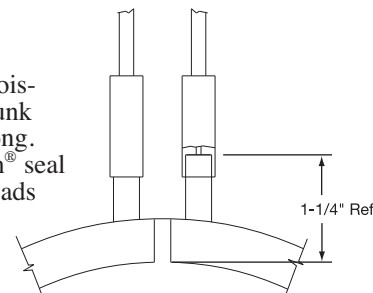

CONTINUED 

Terminations

Maxiband Terminal Protection Terminations

Continued from previous page...



Type EP—Explosion and Moisture Resistant Box

Maxiband heaters can be made with an explosion/moisture resistant box brazed on to the heater.



Explosion resistant terminal housings are intended to provide containment of an explosion in the enclosure only. No portion of the heater assembly outside the enclosure is covered under this NEMA rating.

Abnormal use of a heater which results in excessive temperature can create hazardous conditions such as a fire. Never perform any type of service nor remove the housing cover prior to disconnecting all electrical power to the heater.

Type C3□—General Purpose Terminal Boxes

Terminal Boxes provide a simple and economical way to eliminate all live exposed terminals and electrical wiring that can be a potential hazard. The boxes have a 1/2" trade size knockout (actual diameter 7/8") for standard connectors. The standard termination is Type S, Terminal Lugs. Heaters can be factory prewired with high temperature lead wire, armor cable or stainless steel wire braid.

- C3A**—Standard box only
- C3B**—w/galvanized armor
- C3C**—w/stainless steel armor
- C3D**—w/wire braid

Band Width "X"

1-1/2"	1-7/8"
2-1/2"	2-7/8"
3"	3-3/8"
4"	4-3/8"

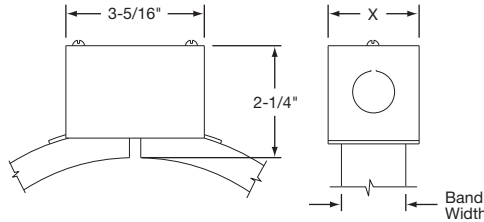

Type P2□—Quick Disconnect High Temperature Plug

Quick Disconnect Plug assemblies are highly recommended to provide the simplest and safest way to apply power to band heater installations.

- P2A**—Box and cup only
- P2B**—w/straight plug
- P2C**—w/str. plug and galvanized cable
- P2D**—w/str. plug and SS cable
- P2E**—w/str. plug and wire braid

Band Width "X"

1-1/2"	1-7/8"
2-1/2"	2-7/8"
3"	3-3/8"
4"	4-3/8"

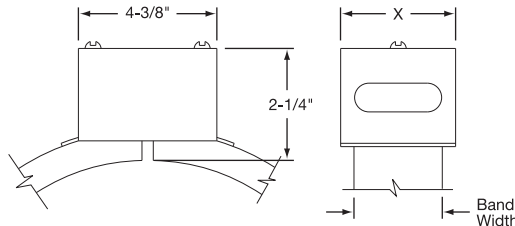

Plug Electrical Ratings

2-Pole 3-Wire Grounding

Max. Amps: 16

Max. Volts: 250 VAC

Max. Temperature: 572°F (300°C)

Maxiband Special Construction Variations



Type EC—Insulated Shroud

Insulated Shroud provides energy savings. Available on all Maxiband widths except 3/4". The shrouds are a separate component part and fit over the Maxiband heater. Insulated shrouds to cover entire heat zones are available and are made to customer specifications. When ordering or for quoting, supply Tempco with a detailed drawing outlining your requirements.

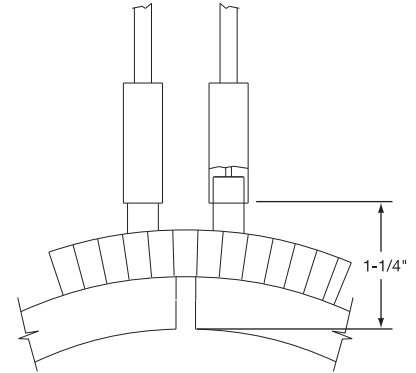

Type SL—Spring-Loaded Clamping

On Maxiband heaters over 12" in diameter, the aluminum tracks are in segments for better configuration, and the straps are equipped with two or more Spring-Loaded Clamping Brackets. For excessively large diameters, four tubular heaters will be used, each heating a 90° section of the total diameter. When terminal boxes are required, two boxes will be used.

NOTE: See page 1-80 for clamping quantity and location details.

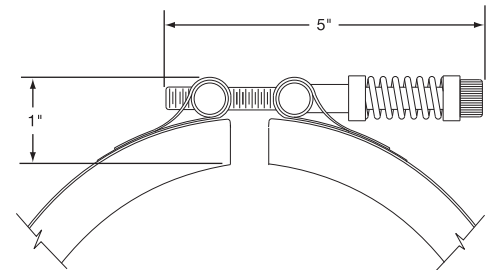

Type RC—Reverse Construction

Reverse Maxibands lend themselves to heating cylindrical surfaces from the inside out.

The specially designed internal brackets exert pressure to both heater halves to assure good contact against the inside diameter of the part being heated. Reverse HLC Maxiband minimum OD is 5-1/2".

Made strictly to customer specifications.

Due to size/construction restrictions, some termination styles are not possible.

Consult Tempco with your requirements.

Maxiband Special Construction Variations

Partial Coverage

Partial coverage band heaters are normally required when holes and cutouts will not allow the heater to sufficiently clear the machine obstructions. The preferred method of construction is the 2-Piece Maxiband Heater with Built-In Brackets. The heater is screwed down to the cylinder at the ends and the Built-In Brackets pull the heater tightly against the cylinder being heated. It is available with all types of construction and termination variations. When ordering provide the angle of coverage from center to center of the mounting screw holes as shown.

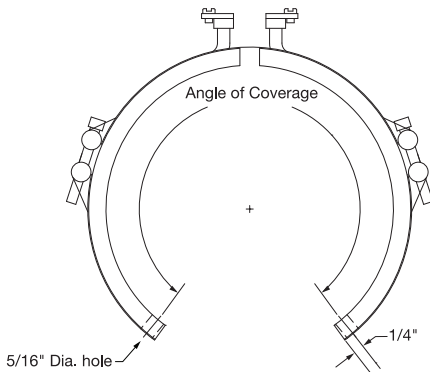

Additional Maxiband Heater Optional Features

Electrical Variations

Dual Voltage — Maxiband heaters can be designed using series/parallel circuits for dual voltage applications. Whether the heater is run on the higher or lower voltage, the wattage will be the same. Dual Voltage is available on all Maxiband heater widths except 3/4".

Ground Terminal or Lead — For those applications requiring a separate ground terminal or lead attached to the heater. A Ground Terminal or Lead is available on any construction or termination variation.

Lead Variations

Electrical Plugs — Industry standard NEMA twist lock electrical connectors are available. The plugs can be attached to fiberglass leads, armor cable or wire braid. Electrical Plugs can be added to any clamping, construction or termination variation.

Terminal Lugs — Various types of crimp terminals can be attached to the heater leads to make wiring into applications quick and easy. High temperature 1200°F (649°C) ring terminals and nylon or PVC insulated terminals are available. Spade, ring, and right-angle or straight quick disconnect type terminals can be attached to the leads.

Extra Cooling Tube Length — The standard cooling tube length is 4". Longer lengths can be provided; please specify when ordering.

Type SC—Square or Rectangular

Square or Rectangular heaters, normally used for heating dies on plastic extruders, are made in a two-piece construction for better clamping and to provide good surface contact. Made strictly to customer specifications. When ordering or for quotation purposes, supply a detailed drawing or sample part.

Consult Tempco with your requirements.



Maxiband “MXB” Heat & Cool with Built-In Cooling Tubes

Maxiband heaters have an exceptionally long operating heater life when compared to other types of band heaters. Highly recommended whenever applicable as an economical alternative to more expensive cast-in aluminum heat and cool band heaters. Available in three different widths: 2-1/2", 3", and 4".

Minimum Inside Diameter: 5".

Consult Tempco if smaller ID is required.

For **complete specifications and terminations** see pages 1-87 through 1-90.

For **cooling tube fittings**, see page 3-52 in the Cast-In Band Heater Section.

Design Features

- * **Rugged Durable Construction**
- * **Withstands Vibration**
- * **Excellent Temperature Uniformity**
- * **Excellent Heat Transfer**
- * **Contamination Resistant**

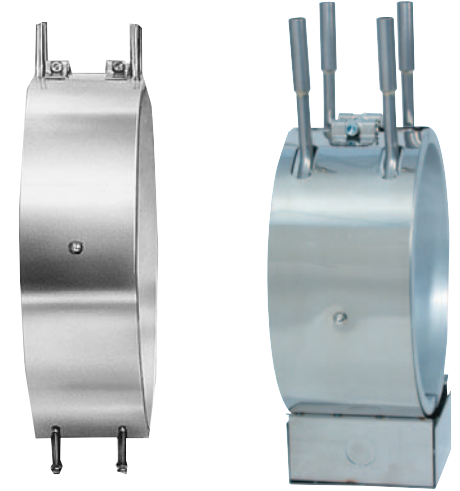

Standard (Non-Stock) HLC Maxibands (Heat & Cool) — 3 in (76.2 mm) Width with 3/8" Diameter Cooling Tube

ID		Wattage	Watt Density		Part Number 240V
in	mm		W/in ²	W/cm ²	
5	127.0	1050	26	4.0	MXB00001
5	127.0	1390	34	5.2	MXB00002
5	127.0	1800	44	6.8	MXB00003
5¼	133.4	1475	34	5.3	MXB00004
5½	139.7	1175	26	4.0	MXB00005
5½	139.7	1560	34	5.3	MXB00006
5¾	146.1	1625	34	5.2	MXB00007
6	152.4	800	16	2.5	MXB00008
6	152.4	1100	22	3.4	MXB00009
6	152.4	1275	25	3.9	MXB00010
6	152.4	1500	30	4.6	MXB00011
6	152.4	1720	34	5.3	MXB00012
6¼	158.8	1300	25	3.8	MXB00013
6¼	158.8	1770	33	5.2	MXB00014
6¼	158.8	1300	25	3.8	MXB00015
6½	165.1	1375	25	3.9	MXB00016
6½	165.1	1820	33	5.1	MXB00017
6¾	171.5	1900	33	5.1	MXB00018
7	177.8	1200	20	3.1	MXB00019
7	177.8	1500	25	3.9	MXB00020
7	177.8	2000	33	5.2	MXB00021
7¼	184.2	2050	33	5.1	MXB00022
7½	190.5	1600	25	3.8	MXB00023
7½	190.5	2120	33	5.1	MXB00024
7¾	196.9	2200	33	5.1	MXB00025
8	203.2	1700	24	3.8	MXB00026
8	203.2	2270	33	5.1	MXB00027
8¼	209.6	2325	32	5.0	MXB00028
8½	215.9	1800	24	3.8	MXB00029
8½	215.9	2410	33	5.0	MXB00030
8¾	222.3	2475	32	5.0	MXB00031
9	228.6	1800	23	3.5	MXB00032
9	228.6	1900	24	3.7	MXB00033
9	228.6	2300	29	4.5	MXB00034
9	228.6	2600	33	5.1	MXB00035
9¼	235.0	1950	24	3.7	MXB00036

ID		Wattage	Watt Density		Part Number 240V
in	mm		W/in ²	W/cm ²	
9¼	235.0	2600	32	5.0	MXB00037
9½	241.3	2000	24	3.7	MXB00038
9½	241.3	2675	32	5.0	MXB00039
9¾	247.7	2050	24	3.7	MXB00040
9¾	247.7	2750	32	5.0	MXB00041
10	254.0	2000	23	3.5	MXB00042
10	254.0	2820	32	5.0	MXB00043
10¼	260.4	2900	32	5.0	MXB00044
10½	266.7	2250	24	3.8	MXB00045
10½	266.7	2975	32	5.0	MXB00046
10¾	273.1	3025	32	4.9	MXB00047
11	279.4	2000	20	3.2	MXB00048
11	279.4	3100	32	4.9	MXB00049
11¼	285.8	3175	32	4.9	MXB00050
11½	292.1	2000	20	3.0	MXB00051
11½	292.1	2450	24	3.7	MXB00052
11½	292.1	3250	32	4.9	MXB00053
11½	292.1	3500	34	5.3	MXB00054
11¾	298.5	3325	32	4.9	MXB00055
12	304.8	2000	19	2.9	MXB00056
12	304.8	2550	24	3.7	MXB00057
12	304.8	3400	32	4.9	MXB00058
12¼	311.2	3475	32	4.9	MXB00059
12½	317.5	2400	21	3.3	MXB00060
12½	317.5	2900	26	4.0	MXB00061
12½	317.5	3000	27	4.2	MXB00062
12½	317.5	3525	32	4.9	MXB00063
12¾	323.9	3600	32	4.9	MXB00064
13	330.2	3670	31	4.9	MXB00065
13½	342.9	3280	27	4.2	MXB00066
13½	342.9	3800	31	4.9	MXB00067
14	355.6	3950	31	4.9	MXB00068
15½	393.7	4000	29	4.4	MXB00069
19	482.6	5400	31	4.8	MXB00070
26	660.4	8000	33	5.2	MXB00071
29	736.6	9000	34	5.2	MXB00072
30	762.0	9500	34	5.3	MXB00073

CONTINUED

Standard Sizes and Ratings

Standard (Non-Stock) HLC (Heat & Cool) Maxibands 4 in (101.6 mm) Width with 3/8" Diameter Cooling Tube

Continued from previous page...

ID		Wattage	Watt Density		Part Number 240V
in	mm		W/in ²	W/cm ²	
5	127.0	1870	34	5.3	MXB00074
5¼	133.4	1970	34	5.3	MXB00075
5½	139.7	1025	17	2.6	MXB00076
5½	139.7	1500	25	3.8	MXB00077
5½	139.7	1800	29	4.6	MXB00078
5½	139.7	2075	34	5.3	MXB00079
5½	139.7	2500	41	6.3	MXB00080
5¾	146.1	2175	34	5.2	MXB00081
6	152.4	2285	34	5.3	MXB00082
6¼	158.8	2370	34	5.2	MXB00083
6½	165.1	2475	34	5.2	MXB00084
6¾	171.5	2575	34	5.2	MXB00085
7	177.8	2675	33	5.2	MXB00086
7¼	184.2	2750	33	5.1	MXB00087
7½	190.5	2845	33	5.1	MXB00088
7¾	196.9	2950	33	5.1	MXB00089
8	203.2	2250	24	3.8	MXB00090
8	203.2	3050	33	5.1	MXB00091
8½	215.9	3255	33	5.1	MXB00092
8¾	222.3	3350	33	5.1	MXB00093

ID		Wattage	Watt Density		Part Number 240V
in	mm		W/in ²	W/cm ²	
9	228.6	3450	33	5.1	MXB00094
9¼	235.0	3545	33	5.1	MXB00095
9½	241.3	3620	33	5.0	MXB00096
9¾	247.7	3725	33	5.0	MXB00097
10	254.0	3820	32	5.0	MXB00098
10½	266.7	4030	33	5.0	MXB00099
11	279.4	4230	32	5.0	MXB00100
11¼	285.8	4325	32	5.0	MXB00101
11½	292.1	4420	32	5.0	MXB00102
11¾	298.5	4500	32	5.0	MXB00103
12	304.8	4600	32	5.0	MXB00104
12½	317.5	4800	32	5.0	MXB00105
12¾	323.9	4900	32	5.0	MXB00106
13¼	342.9	5250	32	5.0	MXB00107
14	355.6	5500	33	5.1	MXB00108
15	381.0	6000	33	5.2	MXB00109
20	508.0	7700	32	4.9	MXB00110

Ordering Information

Standard Heaters

Select a Maxiband MXB from the Standard Sizes and Ratings List on pages 1-91 and 1-92.

If not otherwise specified, MXB heaters are supplied with type "S" termination and 4" long plain cooling tubes.

Custom Engineered/Manufactured Heaters

An electric heater can be very application specific; for sizes and ratings not listed **TEMPCO** will design and manufacture a Maxiband Heater to meet your requirements. **Standard lead time is 3 weeks.**

Please Specify the following:

- | | |
|--|---|
| <input type="checkbox"/> Inside Diameter | <input type="checkbox"/> Termination |
| <input type="checkbox"/> Width | <input type="checkbox"/> Construction |
| <input type="checkbox"/> Total Wattage | <input type="checkbox"/> Clamping |
| <input type="checkbox"/> Voltage per half | <input type="checkbox"/> Special Features |
| <input type="checkbox"/> Lead Cable/Braid Length | <input type="checkbox"/> Quantity |

⚠ WARNING: Cancer and Reproductive Harm - www.P65Warnings.ca.gov.

Maxiband “MXC” Cool Only *with* Built-In Cooling Tubes

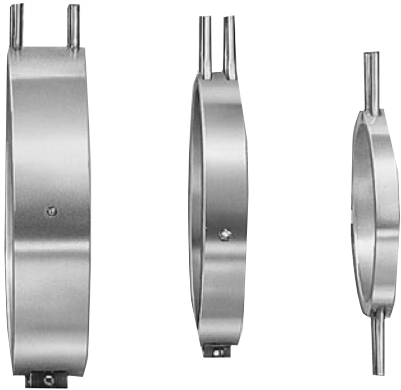

Maxiband MXC Bands are made for cooling only and are available in five standard widths: 3/4", 1-1/2", 2-1/2", 3", and 4". For 3/4" and 1-1/2" wide MXC bands the ends of the stainless steel cooling tubes exit 180° apart. Complete Maxiband specifications can be found on page 1-81.

Minimum Inside Diameter: 5".

Consult Tempco if smaller ID is required.

For **optional cooling tube fittings**, see page 3-52 in the Cast-In Band Heater Section.

Cooling Tube Specifications

Band Width	3/4"	1-1/2"	2-1/2"	3"	4"
Cooling Tube Diameter	3/8"	3/8"	3/8"	3/8"	3/8"
Cooling Tube Extension	4"	4"	4"	4"	4"
Cooling Tube Material	Stainless Steel				



Optional Reverse Construction

Reverse MXC Maxibands lend themselves to cooling cylindrical surfaces from the inside out.

The specially designed internal brackets exert pressure to both heater halves to assure good contact against the inside diameter of the part being cooled. Reverse MXC Maxiband minimum OD is 8". Consult Tempco if smaller OD is required.

Made strictly to customer specifications.

Consult Tempco with your requirements.

Standard (Non-Stock) MXC (Cool Only) Maxibands — with 3/8" Diameter Cooling Tube

0.75 in (19.1 mm) Width

Width		ID		Part Number
in	mm	in	mm	
3/4	19.1	6	152.4	MXC00001
3/4	19.1	6½	165.1	MXC00002
3/4	19.1	7	177.8	MXC00003
3/4	19.1	7½	190.5	MXC00004
3/4	19.1	8	203.2	MXC00005
3/4	19.1	8½	215.9	MXC00006
3/4	19.1	9	228.6	MXC00007
3/4	19.1	9½	241.3	MXC00008
3/4	19.1	10	254.0	MXC00009
3/4	19.1	10½	266.7	MXC00010
3/4	19.1	11	279.4	MXC00011

1.5 in (38.1 mm) Width

Width		ID		Part Number
in	mm	in	mm	
1½	38.1	6	152.4	MXC00012
1½	38.1	6½	165.1	MXC00013
1½	38.1	7	177.8	MXC00014
1½	38.1	7½	190.5	MXC00015
1½	38.1	8	203.2	MXC00016
1½	38.1	8½	215.9	MXC00017
1½	38.1	9	228.6	MXC00018
1½	38.1	9½	241.3	MXC00019
1½	38.1	10	254.0	MXC00020
1½	38.1	10½	266.7	MXC00021
1½	38.1	11	279.4	MXC00022

Ordering Information

See page 1-94

CONTINUED →

Maxiband

Standard (Non-Stock) MXC (Cool Only) Maxibands — with 3/8" Diameter Cooling Tube

Continued from previous page...

2.5 in (63.5 mm) Width

Width		ID		Part Number
in	mm	in	mm	
2½	63.5	6	152.4	MXC00025
2½	63.5	6½	165.1	MXC00026
2½	63.5	7	177.8	MXC00027
2½	63.5	7½	190.5	MXC00028
2½	63.5	8	203.2	MXC00029
2½	63.5	8½	215.9	MXC00030
2½	63.5	9	228.6	MXC00031
2½	63.5	9½	241.3	MXC00032
2½	63.5	10	254.0	MXC00033
2½	63.5	10½	266.7	MXC00034
2½	63.5	11	279.4	MXC00035

3 in (76.2 mm) Width

Width		ID		Part Number
in	mm	in	mm	
3	76.2	6	152.4	MXC00037
3	76.2	6½	165.1	MXC00038
3	76.2	7	177.8	MXC00039
3	76.2	7½	190.5	MXC00040
3	76.2	8	203.2	MXC00041
3	76.2	8½	215.9	MXC00042
3	76.2	9	228.6	MXC00043
3	76.2	9½	241.3	MXC00044
3	76.2	10	254.0	MXC00045
3	76.2	10½	266.7	MXC00046
3	76.2	11	279.4	MXC00047
3	76.2	11½	292.1	MXC00048
3	76.2	12	304.8	MXC00049
3	76.2	12½	317.5	MXC00050
3	76.2	13	330.2	MXC00051
3	76.2	13½	342.9	MXC00052
3	76.2	14	355.6	MXC00053

4 in (101.6 mm) Width

Width		ID		Part Number
in	mm	in	mm	
4	101.6	6	152.4	MXC00055
4	101.6	6½	165.1	MXC00056
4	101.6	7	177.8	MXC00057
4	101.6	7½	190.5	MXC00058
4	101.6	8	203.2	MXC00059
4	101.6	8½	215.9	MXC00060
4	101.6	9	228.6	MXC00061
4	101.6	9½	241.3	MXC00062
4	101.6	10	254.0	MXC00063
4	101.6	10½	266.7	MXC00064
4	101.6	11	279.4	MXC00065
4	101.6	11½	292.1	MXC00066
4	101.6	12	304.8	MXC00067
4	101.6	12½	317.5	MXC00068
4	101.6	13	330.2	MXC00069
4	101.6	13½	342.9	MXC00070
4	101.6	14	355.6	MXC00071

Ordering Information

Standard

Select a Maxiband MXC from the Standard Sizes listed on pages 1-93 and 1-94.

If not otherwise specified, MXC bands are supplied with 4" long plain cooling tubes.

Custom Engineered/Manufactured Bands

Understanding that a cooling band can be very application specific, for sizes not listed **TEMPCO** will design and manufacture a Maxiband Cool Only to meet your requirements. **Standard lead time is 2 weeks.**

Please Specify the following:

- | | |
|---|---------------------------------------|
| <input type="checkbox"/> Inside Diameter | <input type="checkbox"/> Clamping |
| <input type="checkbox"/> Width | <input type="checkbox"/> Construction |
| <input type="checkbox"/> Special Features | <input type="checkbox"/> Quantity |

⚠ WARNING: Cancer and Reproductive Harm - www.P65Warnings.ca.gov.

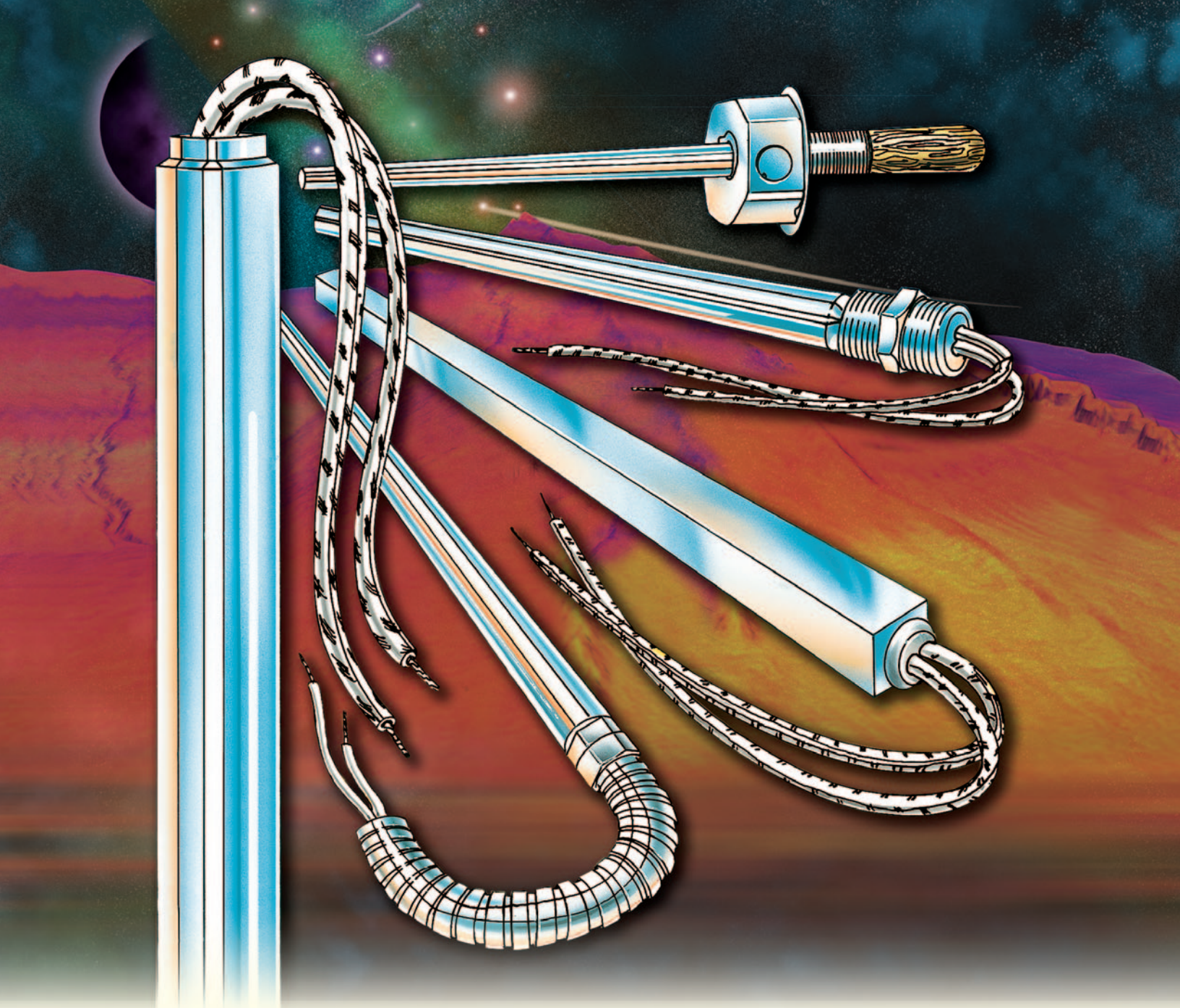

Table Of Contents

Pictorial Index	A-6	OEM Replacement Heaters:	
Hi-Density Cartridge Heaters (US sizes).....	2-2	For Runnerless Molding Systems	2-26
Miniature 1/8" Diameter Hi-Density Cartridge Heaters	2-10	For Underwater Pelletizer Die	2-27
Hi-Density Terminator Program	2-12	Hi-Density Cartridge Heaters (Metric Sizes)	2-28
Type F Terminated Stock Heaters.....	2-22	Low-Density Cartridge Heaters.....	2-34
Hi-Density Immersion Heaters	2-23	Cartridge Heater Terminations & Options	2-39
Hi-Density Pennybottom™ Heaters	2-24	Hi-Density Bolt Heaters	2-61

2

section

Cartridge Heaters

Hi-Density

CARTRIDGE HEATER FEATURES

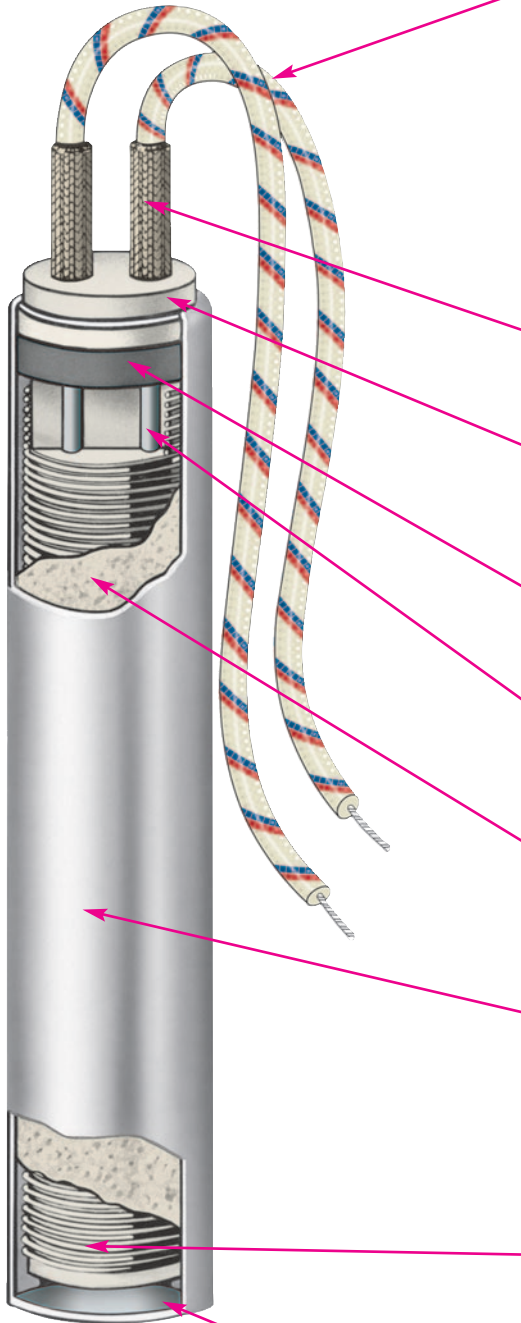

A The standard termination for Hi-Density Cartridge Heaters is Type N, 10" (254 mm) long nickel conductor lead wires externally connected to 1-1/4" (32 mm) solid conductor terminal pins. The lead wires have fiberglass insulation and are UL approved for temperatures up to 482°F (250°C). Mica insulated UL approved wires for temperatures up to 842°F (450°C) are optional.



Note: To meet the requirements of your application we offer over 40 standard termination styles to select from that will solve many of the most common application problems. See pages 2-39 through 2-60.

B High temperature fiberglass sleeve provides maximum electrical insulation to the crimp connector used to splice the nickel conductors to the flexible leads.

C Ceramic end cap prevents nickel conductors from shorting out against sheath when sharp bending of the leads is required. The ceramic cap may be eliminated in some cases to optimize the heater watt density.

D Ceramic end cap and swaged-in lava plug protect the internal cartridge from outer contamination. Other types of seals can also be provided.

E Solid conductor terminal pins are used to ensure a good electrical connection between the nickel conductor lead wires and the resistance wire. They are sized for the maximum current rating of the heater.

F A high purity Magnesium Oxide (MgO) powder consisting of custom grain sizes is used to fill all remaining space inside the sheath. Heater is then swaged, which compacts the magnesium oxide grains into a solid mass, thereby increasing thermal conductivity and dielectric strength.

G Standard sheath material is 321 Stainless Steel. It provides high temperature strength up to 1200°F (650°C), good thermal conductivity, and resistance to corrosion and scaling. Alloy 321 is a Nickel-Chromium Stainless Steel modified with the addition of Titanium. For higher operating temperatures up to 1400°F (760°C) or corrosive immersion heating applications, Incoloy® 800 is available. Consult Tempco for other sheath materials.

H Grade "A" Nickel-Chrome resistance wire precisely wound on a high purity magnesium oxide core places the resistance wire as close to the inside of the sheath as possible while maintaining dielectric strength. This provides excellent heat transfer and long heater life with the highest possible watt densities.

I Welded end disc made from the same material as the sheath provides a positive seal against moisture and other contaminants.



Hi-Density Cartridge Heaters are UL recognized and CSA certified in many design variations under UL File Number E65652 and CSA File Number 043099.

If you require UL and/or CSA Agency Approval, please specify when ordering.

TEMPCO Offers the Most Comprehensive and Diverse Selection in Hi-Density Cartridge Heaters

Since Their Introduction in 1972, Hi-Density Cartridge Heaters Have Evolved and Today Offer a Multitude of Diverse Product Options:

1. **(HDC)** A Hi-Density cartridge heater in US sizes (see page 2-4).
2. **(HDM)** A Hi-Density cartridge heater in Metric sizes (see page 2-28).
3. **(HDP)** Pennybottom™, A Hi-Density cartridge heater with a Built-in Thermocouple and Flat Copper end disc. (see page 2-24).
4. **(HDL)** A Hi-Density cartridge heater designed with NPT Fittings for Immersion heating (see page 2-23).
5. **(HDB)** Bolt Heater, A Hi-Density cartridge heater designed for assisting in the assembly of large machinery (see page 2-61).

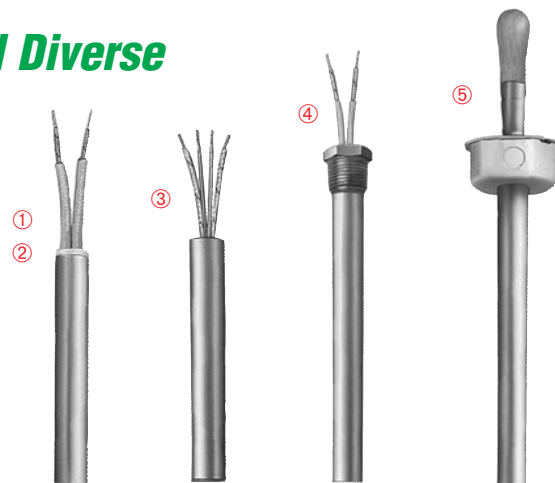

Hi-Density Cartridge Heaters provide maximum processing temperature capability

- * Higher watt densities permit smaller heaters to be used without sacrificing life expectancy. This results in up-front as well as long-term cost savings.
- * Swaged construction provides maximum support for the resistance wire and excellent heat transfer characteristics, improving the overall life expectancy of the cartridge heater.
- * Termination styles and special features allow customization to any application.
- * Applications up to 1400°F (760°C)

Typical Applications

- ✦ Plastic Extruders
- ✦ Hot Runner Molds
- ✦ Hot Stamping
- ✦ Medical Equipment
- ✦ Packaging Equipment
- ✦ Molds
- ✦ Aerospace
- ✦ Sealing Bags
- ✦ Semi-Conductor
- ✦ Plastic Molding
- ✦ Shoe Machinery
- ✦ Food Processing
- ✦ Heating Gases and Liquids
- ✦ Glue Guns
- ✦ Laminating Presses
- ✦ Platens
- ✦ Scientific Equipment
- ✦ Food Service Equipment

Hi-Density Cartridge Heaters are Classified in Two Distinct Categories

Multi-Purpose Use

The Multi-Purpose Use Cartridge Heaters represent Tempco's commitment to value-added customer service as we maintain in Stock over 65,000 Semi-Finished Hi-Density Cartridge Heater Substrates, offering a combination of over 1000 sizes in industry standard diameters and lengths ranging from 1" (25.4 mm) to 36" (914.4 mm) in a complete spectrum of wattages and operating voltages. Multi-Purpose Use Cartridge Heaters are the solution for a multitude of original equipment manufacturers (OEMs) or maintenance (MRO) applications.

Available through the Terminator Program.

Complete details are found on pages 2-12 through 2-21.

Highly Engineered Specific Purpose Use

Tempco has been at the forefront of addressing the challenges of Original Equipment Manufacturers (OEMs) in a broad segment of diversified industries. As a company we are uniquely qualified and committed to providing value-added expertise in engineering and manufacturing capabilities that span over three decades of acquired knowledge, assisting customers in developing highly engineered specific use cartridge heaters for dependable and reliable performance. Let us provide the optimal solution to your thermal loop system and cartridge heater design challenges. Engineering assistance can be found on pages 2-5 through 2-7.

Consult Us With Your Requirements.

We Welcome Your Inquiries.

Ordering Information

**Custom
Manufactured**



Custom Engineered/Manufactured Heaters

Because an electric heater can be very application specific, for sizes and ratings not listed, **TEMPCO** will design and manufacture a Hi-Density Cartridge Heater to meet your requirements. **Standard lead time is 3 weeks.**

Please Specify the following:

- | | |
|-----------------------------------|--|
| <input type="checkbox"/> Diameter | <input type="checkbox"/> Termination types (see pages 2-39 through 2-60) |
| <input type="checkbox"/> Length | <input type="checkbox"/> Lead Length |
| <input type="checkbox"/> Wattage | <input type="checkbox"/> Cable/Braid length |
| <input type="checkbox"/> Voltage | <input type="checkbox"/> Special Features |
| | <input type="checkbox"/> Application Type |
| | <input type="checkbox"/> Operating Temperature |

⚠ WARNING: Cancer and Reproductive Harm - www.P65Warnings.ca.gov.

(800) 323-6859 • Email: sales@tempco.com

Cartridge Heaters



Standard Specifications

Hi-Density Cartridge Heater Specifications

PERFORMANCE RATINGS

Max. Temperature: *1400°F (760°C)
Max. Watt Density: 100-300 W/in² (15.5-46.5 W/cm²)
 depending on heater size & operating temperature.

NOTE: The maximum operating temperature and the life expectancy of a cartridge heater is dependent on two main factors:
 1. The maximum recommended sheath temperature (*1200°F for a standard heater)
 2. The maximum ambient temperature for the termination selected.
 Consult Tempco if you require a recommendation for your application.

DIMENSIONAL SPECIFICATIONS

Nominal Diameter	1/8"	1/4"	5/16"	3/8"	1/2"	5/8"	3/4"	1"
	in (mm)	in (mm)	in (mm)	in (mm)	in (mm)	in (mm)	in (mm)	in (mm)
Actual Diameter	.122 (3.10)	.246 (6.25)	.308 (7.82)	.371 (9.42)	.496 (12.60)	.621 (15.77)	.746 (18.95)	.996 (25.30)
Diameter Tolerance	±.002 (.051)	±.002 (.051)	±.002 (.051)	±.002 (.051)	±.002 (.051)	±.002 (.051)	±.003 (.076)	±.003 (.076)
Minimum Length	1.25 (31.8)	1 (25.40)	1 (25.40)	1 (25.40)	1 (25.40)	1 (25.40)	1-1/4 (31.75)	1-3/4 (44.45)
Maximum Length	12 (305)	36 (914)	36 (914)	48 (1219)	60 (1524)	72 (1829)	72 (1829)	72 (1829)
Length Tolerance	±3/32 (2.4) Heaters up to 3.5" (89 mm)	±3/32 (2.4)	±3/32 (2.4)	±3/32 (2.4)	±3/32 (2.4)	±3/32 (2.4)	±1/8 (3.2)	±1/8 (3.2)
	±3% of Sheath Length Heaters over 3.5" (89 mm)	±2% of Sheath Length Heaters over 5" (127 mm)						
Camber Tolerance Heaters to 12" (305 mm) long	—	0.010" (.254 mm) per foot of length						
Camber Tolerance Heaters over 12" (305 mm) long	—	0.020" (.508 mm) per foot of length						

A certain amount of Camber is unavoidable. With a slight force, Hi-Density Cartridge Heaters will flex enough to fit into a straight reamed hole.

ELECTRICAL SPECIFICATIONS

Nominal Diameter	1/8"	1/4"	5/16"	3/8"	1/2"	5/8"	3/4"	1"
Maximum Voltage	240	240	240	240	240	480*	480*	480*
Maximum Amperage (see next line for exceptions)	3.0	4.4	4.5	6.7	10.5	23	23	23
†Maximum Amperage for Types C1C, C1D, C2C, C2D, CS, F, M3, R1B, S1, S2, SA, W & W3 Terminations	—	3.0	3.0	5.5	7.6	9.7	9.7	9.7
Minimum Wattage at 120V on a 1" long Heater	—	50	45	45	50	50	—	—
Minimum Wattage at 120V on a 2" long Heater	5	20	20	20	20	20	20	20
Maximum Wattage at 120V	360	525	540	800	1260	2760	2760	2760
Maximum Wattage at 240V	720	1050	1080	1600	2520	5520	5520	5520
Maximum Wattage at 480V	—	—	—	—	—	11,000	11,000	11,000
Wattage Tolerance	+10,-15%		Plus 5%, Minus 10%					
Resistance Tolerance	+15,-10%		Plus 10%, Minus 5%					

†Current carrying capacities are for ambient temperatures up to 482°F (250°C) with mica insulated lead wires.
 *480V when applicable. Consult Tempco.

LENGTH TOLERANCE FOR: - LEAD WIRES - WIRE BRAID LEADS - ARMOR CABLE LEADS

Up to 36": -1/2", +1" (-12.7 mm, +25.4 mm)
 36" to 72": -1", +2" (25.4 mm, +50.8 mm)
 Above 72": ±4" (101.6 mm)



Note: Specifications detailed on this page are standard. Consult Tempco if your application requires tighter tolerances or has other special requirements.

TEMPERATURE COEFFICIENT OF RESISTANCE

The electrical resistance (ohms) of the heater resistance wire increases with temperature rise.

Tempco standard Hi-Density Cartridge Heaters are manufactured with ohms (cold ohms) 3.3% lower than the actual calculated ohms (hot ohms) to compensate for this increase.

AVAILABLE ELECTRICAL FEATURES

Diameter	Dual Volts	3-Phase	Dual Circuits	Multiple Heat Zones (maximum 3 zones)
1/8"	No	No	No	No
1/4"	No	No	No	No
5/16"	No	No	No	No
3/8"	Yes*	No	No	Yes*
1/2"	Yes*	Yes	Yes	Yes*
5/8"	Yes	Yes	Yes	Yes
3/4"	Yes	Yes	Yes	Yes
1"	Yes	Yes	Yes	Yes

Consult factory for maximum wattages and voltages.

* Heaters may require a larger diameter transition area at lead end.

[View Product Inventory @ www.tempco.com](http://www.tempco.com)

Recommendations for Improving the Life of Hi-Density Cartridge Heaters

Tempco Hi-Density Cartridge Heaters have been widely used in many demanding and diverse applications since 1972. The commonly used basic applications are platen, plastic mold and die heating, liquid immersion and air heating.



Note: Selection of the wrong termination for a particular application is the primary reason for all heater failures. However, failure to consider other important criteria can also have a negative effect on the life of the heater. To get the best performance and assure long life, it is important to carefully evaluate the following factors.

Operating Temperature

Operating temperature of a heater is a major factor in determining the life expectancy of a heating element. The heater life depends on the actual temperature of the resistance wire within the heater and not on the process operating temperature. The graph in Fig. 1 demonstrates the proper relationship between operating temperature and watt density; the higher the operating temperature, the lower the maximum recommended watt density.

Heater Watt Density

Cartridge heater watt density is defined as the wattage dissipated per square inch of the heated sheath surface. For a particular application a heater's watt density governs internal resistance wire temperature, which determines the outer sheath temperature. These factors are critical to the proper heating of the application and to the life expectancy of the heater. Special construction features that promote excellent heat transfer permit Hi-Density Cartridge Heaters to operate at higher watt densities while maintaining the lowest possible resistance wire temperatures of any style cartridge heater.

Heater watt density (w/in^2) is calculated using the following formula:

$$\text{Watt Density} = \frac{\text{Heater wattage}}{\text{Heated length} \times \text{Heater diameter} \times 3.1416}$$

Heated length is the overall length of the heater minus any unheated (cold) sections. Standard Type N, Hi-Density cartridge heaters have 3/8" at the lead end and 1/4" at the disc end unheated. This would mean a 6" long heater would have 5-3/8" effective heated length. Unheated sections vary with type of heater termination. For descriptions of terminations and options, see pages 2-39 through 2-60.

The graph in Fig. 1 shows the maximum recommended watt density for Hi-Density Cartridge Heaters when used in a steel platen. Watt density limitations for various materials are given in the engineering section of this catalog. For liquid immersion heaters the maximum watt density depends on the type of liquid being heated. The more viscous, or thicker the liquid, the lower the maximum watt density. Higher watt density can cause the liquid to carbonize and accumulate on the heater sheath, which will cause premature heater failure. It is advisable to use heaters that have watt densities below the maximum recommended watt density to get the longest heater life. If the actual heater watt density is close to the maximum recommended watt density, you can correct the problem by:

1. Increasing the number, diameter and length of heaters.
2. Lowering the total wattage; however, this may increase the heat-up time.
3. Obtaining tighter fit (see Fig. 2 — Determining Fit).

A Hi-Density cartridge heater designed at the maximum recommended watt density allows the smallest heater to be used to obtain the required wattage with good service life. All things being equal, using a lower watt density heater will typically provide optimized service life.

FIG. 1
Recommended Watt Density for Heating Metal Parts

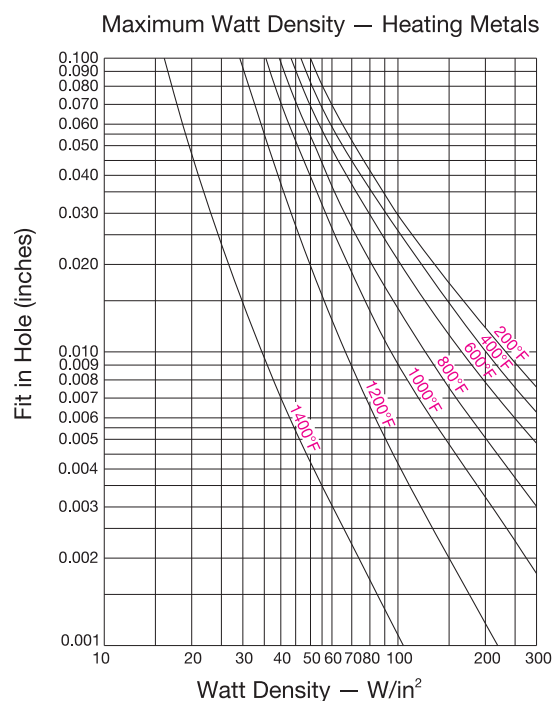

The graph shows the recommended maximum watt density for Tempco Hi-Density cartridge heaters at different operating temperatures and fit, when the heater is installed in an oxidized mild steel block. The thermocouple is located 1/2" from the heater. When heating other materials, the data needs to be extrapolated based on the thermal conductivity of the material. Consult Tempco with your requirements.

FIG. 2
Determining Fit

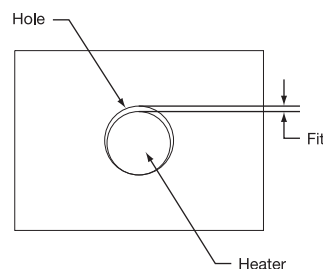

CONTINUED

Recommendations for Improving the Life of Hi-Density Cartridge Heaters

Continued from previous page...

Determining Fit

When heating a platen, mold, die or hot runner probe with Hi-Density Cartridge Heaters inserted into drilled holes, fit is an important factor in determining the life expectancy of the heater. Fit is the difference between the minimum diameter of the cartridge heater and the maximum diameter of the hole. Unheated sections on a Hi-Density cartridge may be smaller in diameter due to swaging. To determine fit, use the smallest diameter on the heated length only.

Example: A 3/8" nominal OD Hi-Density cartridge heater has an actual diameter of .371" \pm .002, which translates to a minimum diameter of .369". If used in a .376" \pm .002 hole, the fit would be .009" (.378" - .369" = .009").

When medium watt density heaters (less than 60 watts per square inch) are used in low temperature applications (less than 600°F [315°C]) general purpose drills are commonly used to drill holes. The typical hole size may be .003" to .008" over the drill size. For higher watt density and/or higher temperature applications, we recommend that the holes are drilled and reamed for the tightest possible fit. In applications where precise temperature control and heat transfer properties are required, Hi-Density cartridge heaters can be centerless ground to \pm .0005".

Although a tighter fit is desirable to efficiently transfer heat and to get long heater life, a looser fit will aid in installing and removing heaters, especially long heaters. We recommend that you apply Tempco's BNS anti-seize cartridge heater coating as it will improve heat transfer and will make the removal of heaters easier.

The graph in Fig 1. (page 2-5) shows the effect of fit in determining the maximum recommended watt density on a steel platen. As it is indicated in the graph, the tighter the fit, the higher the maximum recommended watt density.

Temperature Control and Location of Temperature Sensing Device

In order to better control the heater temperature and hence the resistance wire temperature, use of an appropriate temperature control and the proximity of the heater to the sensor is very important. The graph in Fig. 1 (page 2-5) shows the effect of operating temperature in determining the maximum recommended watt density on a steel platen where the sensor is located 1/2" from the heater. Higher watt density heaters can generate heat faster than the surrounding area's ability to dissipate heat. This creates a thermal lag between the heater and the sensor. The closer the sensor to the heater, the better you can control the heater temperature. By keeping the sensor further from the heater, temperature gradients of several hundred degrees can be observed in many applications, especially during initial start-up and heavy thermal cycling. Although the set operating temperature may be low, the heater may be running at a very high temperature. This is a common cause of heater failure. This can be minimized using time proportional and PID functions of the temperature controllers. See Section 13 for temperature controllers and Section 14 for thermocouples and sensors.

Power Control

Power control methods affect the life expectancy of heating elements. In general, although economical, on-off controls increase thermal fatigue and oxidation rate on heating elements by causing wide temperature swings of the internal heating element. Silicon Controlled Rectifiers (SCRs), Mercury Relays and Solid State Power Controls can increase the life expectancy of heating elements by reducing the temperature swings of the internal heating element. See Section 13 for power controls.

Common Causes of Cartridge Heater Failures

Contamination

Contamination is a major cause of heater failure. Moisture, hydraulic oils, and melted plastic are the most common contaminants that are seen on failed heaters. Since the magnesium oxide insulation in a Hi-Density heater is hygroscopic in nature, moisture is easily absorbed into the heater and typically results in premature heater failure. Moisture absorption during machine washdown or cleanup also is a frequent problem. These contaminants, which are electrically conductive, will short out the heater. Most probably, the failures will be at the lead end of the heater and in some cases can split or blow a hole on the heater sheath. The disc end of a Hi-Density cartridge heater is welded shut with a stainless steel disc.

Generally, contaminants enter the heater through the lead end of the heater. The high temperature lead wires used on Hi-Density heaters have fiberglass or mica insulation. Oil and moisture can wick through the insulation on the lead wire into the heater. Tempco offers a wide variety of terminations to avoid this problem, including epoxy seals, Teflon® seals, convoluted cables, welded end discs, Teflon® insulated lead wires and SJO cable. However, there are temperature limitations on many of these terminations.



Note: If you should encounter premature cartridge heater failure, consult Tempco. Our team of professionals will have the solution to your problem.

Excessive Flexing of Leads

Tempco Hi-Density heaters use flexible grade A nickel stranded lead wires with fiberglass or mica insulation. On certain terminations the lead wires are connected externally to solid nickel conductor pins. In applications where there is excessive movement or vibration, the solid pins could break due to fatigue. A simple solution is to give enough slack on the leads to minimize the stress on the solid pins or provide an internal lead wire connection within the heater. Tempco also offers strain relief brackets and springs to prevent this problem.

Where heater leads can wear out by abrasion due to excessive flexing of the leads, Tempco offers several abrasion resistant terminations. See pages 2-41 through 2-47.

Lack of Heat Sink

Hi-Density heaters are designed with minimum unheated (cold) sections. If the heated sections project from the platen or mold, these sections will get extremely hot due to lack of heat transfer. This will lead to premature heater failure. Tempco can manufacture heaters with cold sections anywhere along the length of the heater to prevent overheating of the heater sheath.

When a Hi-Density heater is used as a liquid immersion heater, make sure the heater's sheath length is completely immersed in the liquid. The heater lead end should not be immersed in liquid, since most of the lead end seals are only moisture resistant, not moisture proof.

Recommendations for Improving the Life of Hi-Density Cartridge Heaters

High Operating Temperature

Tempco Hi-Density heaters are designed to operate at sheath temperatures up to 1400°F (760°C). When process temperatures approach the maximum heater sheath temperature, make sure the sheath temperature doesn't exceed its limitations. Location of the thermocouple and the type of temperature and power controls are factors that affect sheath temperature and potential overshoot conditions.

Although the heater is designed to run at temperatures up to 1400°F (760°C), heater lead wires and terminations are rated for much lower temperatures. Care should be taken to make sure that the heater lead end temperatures do not exceed their limitations. Heaters can be made longer with unheated sections at the lead end to bring the lead end out of the high temperature area. Tempco can also provide you with a high temperature wiring harness, which can withstand temperatures up to 1400°F (760°C). See page 15-5 in the accessories section for details.



Note: As explained in the above paragraphs, the single major cause for cartridge heater failure is the selection of the wrong type of heater lead end termination for the specific application. To assist you in selecting the right termination type, pages 2-39 through 2-57 give detailed descriptions of over 40 terminations designed to solve many of the common application problems. If you need further assistance, consult Tempco.

High Wattage Rating

Heaters with very high wattage ratings can create temperature overshoots, uneven temperature distribution and high heater sheath temperatures, causing premature heater failure.

For liquid immersion heaters, maximum watt density depends on the type of liquid being heated. The heavier or thicker the liquid, the lower the maximum watt density. Higher watt density can cause the liquid to carbonize and accumulate on the heater sheath, which will cause premature heater failure.

Scale and Sludge Buildup

In liquid immersion applications, periodic cleaning of the heater sheath is necessary to remove any scale buildup on the sheath. Scale can accumulate on the sheath and cause the heater to overheat and fail. When used to heat liquid in a tank, be sure to clean any sludge from the bottom of the tank. A heater sheath covered with sludge will overheat and fail.

Important Installation Considerations

- For closest fit and best heat transfer, use reamed holes.
- When possible, drill holes through the object being heated. This will make heater removal easier.
- When using an anti-seize coating like Tempco's BNS spray or paste, **do not apply** over lead wires or any other current carrying conductors.
- When using insulated tape or sleeving, check to make sure it is rated for the temperature of the application. Lower temperature rated materials can contain an adhesive or binder that can carbonize and become electrically conductive.
- When using heaters near their maximum recommended watt density, it is recommended that the temperature sensing probes be at maximum 1/2" from the heater sheath.
- Lead wires should not be located in the hole containing the cartridge heater during operation. This may cause the lead wires to be exposed to temperatures above their rated temperature.
- When used in a vacuum application, make sure the lead end of the heater is outside the vacuum. If the lead has to be in the vacuum, consult Tempco for specific recommendations.
- Many applications will subject a heater's electrical terminations to one or more of the following potentially damaging conditions:
 - Moisture
 - Oil and other contaminants
 - Flexing
 - Abrasion
 - High temperature



Note: To protect the heater from damage in these harsh environments, Tempco has a wide selection of terminations and options available. See pages 2-39 through 2-60 for details.

BNS Anti-Seize Cartridge Heater Coating

This high temperature, electrically insulating and thermally conductive coating will minimize oxidation and improve heat transfer from heater to the object being heated.

Brush a thin layer of paste or spray lightly over the cartridge heater prior to inserting the heater into a hole.



Do not apply over lead wires or other bare current carrying conductors, since the water in the paste and spray can cause an electrical short circuit.



13 oz.
Aerosol spray can

Part Number:
CML00010

- * Temperature Range 1562°F (850°C)
- * High Heat Transfer



4 oz.
Paste w/brush applicator top
Part Number: CML00020

- * Temperature Range 1562°F (850°C)
- * High Heat Transfer



Note: Formulated to assist in the removal of cartridge heaters.

All Items Available from Stock

Highly Engineered Custom Manufactured Specific Use Cartridge Heaters

Meeting the Challenges of Original Equipment Manufacturers with Custom Engineering

Tempco has been at the forefront of addressing the challenges of original equipment manufacturers (OEMs) in diversified industries, when dependable and reliable performance of custom engineered cartridge heaters is crucial to the overall operating efficiency and quality of their equipment and machinery.

Tempco is a company uniquely qualified and committed to providing value-added expertise in engineering and manufacturing that spans over four decades of acquired knowledge, assisting customers in developing highly engineered specific use cartridge heaters for equipment and/or machinery systems.

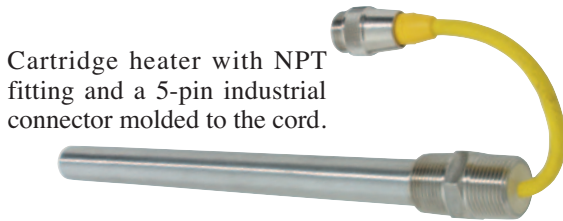

Cartridge heater with NPT fitting and a 5-pin industrial connector molded to the cord.



Cartridge heater for continuous air heating application with Incoloy® sheath, custom machined fitting and silicone rubber moisture barrier.



Cartridge heater with built-in thermal fuse and ground wire for X-Ray processing equipment.



Cartridge heater with built-in thermostat, pipe fitting and ground leads for oil heating in waste handling equipment.



Finned Cartridge Oil Immersion Heater with a liquid-tight electrical termination.

Complete a New Project on Time, Improve Efficiencies and Reduce Cost

Consult Tempco, your strategic partner, in the early stages of a new project requiring cartridge heaters, or to improve a troublesome existing application. By doing so you allow Tempco to place at your disposal our team of professionals, offering you our vast knowledge in product design and manufacturing expertise. We can provide you with the optimal solution to your thermal loop system and cartridge heater design challenges.

Tempco offers you the perfect balance in quality and service with value-added technology. These pictures depict a small sampling of the cartridge heaters we have developed for special applications. Put our knowledge and experience to work for you.

*Our capabilities are limited only by your imagination.
Consult us with your requirements.
We welcome your inquiries.*

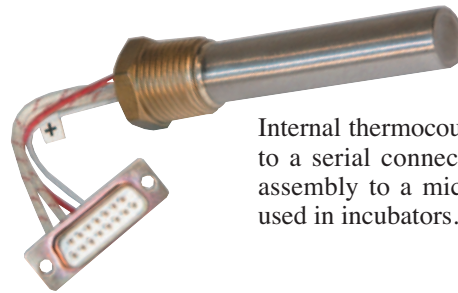

Internal thermocouple is wired to a serial connector for easy assembly to a microprocessor used in incubators.



Incoloy® fitting and seamless Incoloy® 800 sheath material used in an aviation application.



Straight armor cable and adjustable bayonet cap for easy assembly.

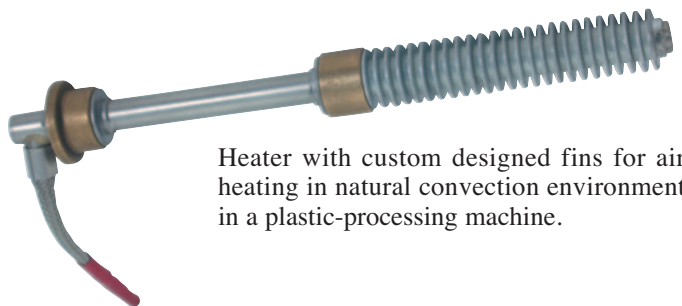

Heater with custom designed fins for air heating in natural convection environment in a plastic-processing machine.

Highly Engineered Custom Manufactured Specific Use Cartridge Heaters



The heater has a header cap as an integral part of the fitting. Leads exit through small holes that are sealed with epoxy for moisture protection.

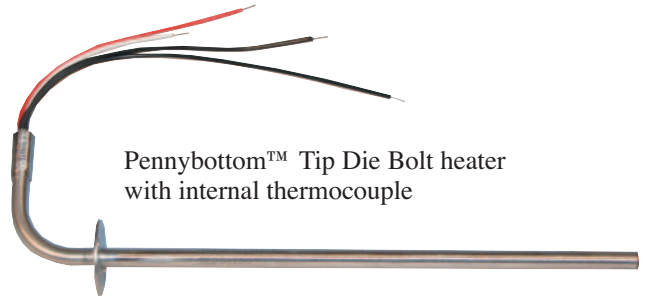

Pennybottom™ Tip Die Bolt heater with internal thermocouple



Heater designed to run continuously at 1202°F (650°C); built-in isolated thermocouple and ground wire.

Heater for medical diagnostic instruments has an integrated heat sink and thermal fuse.

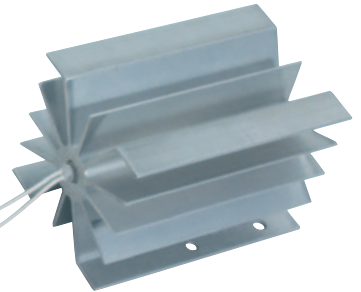

SJO cord and molded plug for automotive air conditioning recharging units.

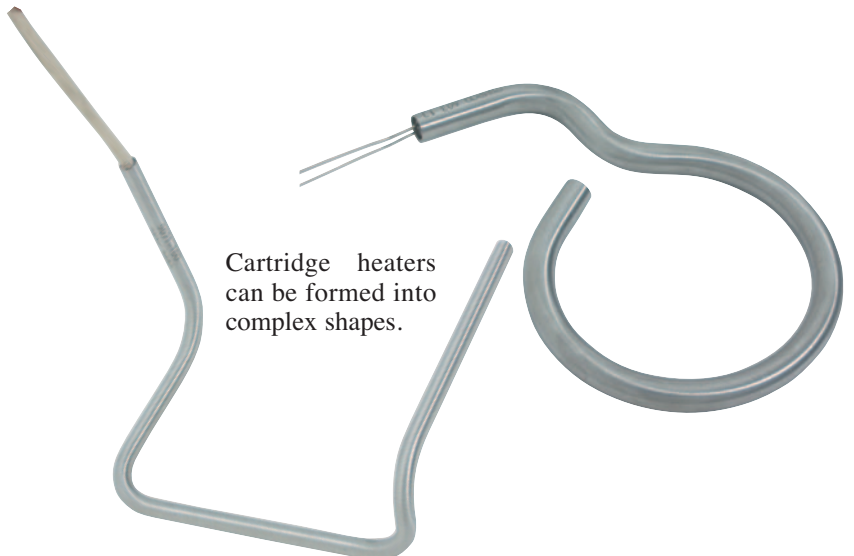

Cartridge heaters can be formed into complex shapes.

Optional Inspection Services and Test Reports

Die Penetrant Test

This non-destructive testing can detect imperfections in weld joints. For critical applications, each individual heater's weld joints by end cap and fittings can be tested. Certified test reports will be sent with each shipment.

Hydrostatic Pressure Test

Cartridge heaters with attached pipe fittings can be pressure tested to your specifications at Tempco. Our in-house testing capabilities can ensure that your products meet your exact specifications.

Electrical Tests

Our state of the art test meter can perform AC/DC dielectric withstand test (Hypot) up to 5000 volts while measuring leakage current in micro amps. It can also measure Insulation resistance (IR) and heater element resistance. Heaters can be serialized and test reports can be sent with each shipment if required.

*Consult Tempco with Your Requirements.
We Welcome Your Inquiries.*

Cartridge Heaters



Hi-Density Miniature

Hi-Density 1/8" Diameter Miniature Cartridge Heaters

PERFORMANCE RATINGS

Max. Temperature: 1200°F (649°C)

Max. Watt Density: 100-200 W/in² (15.5-31 W/cm²)
depending on operating temperature.

NOTE: The maximum operating temperature and the life expectancy of a cartridge heater is dependent on two main factors:

1. The maximum recommended sheath temperature
 2. The maximum ambient temperature for the termination selected
- Consult Tempco if you require a recommendation for your application.

DIMENSIONAL SPECIFICATIONS

Nominal Diameter	1/8"	
	in	(mm)
Actual Diameter	.122	(3.10)
Diameter Tolerance	±.002	(.051)
Minimum Length	1.25	(31.8)
Maximum Length	12	(305)
Length Tolerance Heaters up to 3.5" (89 mm) long	±3/32 (2.4)	
Length Tolerance Heaters over 3.5" (89 mm) long	±3% of Sheath Length	

SHEATH MATERIAL

Standard: Type 304 Stainless Steel

Optional: Inconel 600

ELECTRICAL SPECIFICATIONS

Nominal Diameter	1/8"
Maximum Voltage	240
Maximum Amperage	3.0
Maximum Wattage at 120V	360
Maximum Wattage at 240V	720
Wattage Tolerance	+10,-15%
Resistance Tolerance	+15,-10%

1/8" Actual .122" (3.10 mm) Diameter Hi-Density Cartridge Heaters with Type N Termination (10" leads)

Sheath Length		Watts	Watt Density		Part Number	
in	mm		W/in ²	W/cm ²	120V	240V
1¼	31.8	25	90	14	HDC19100	—
1¼	31.8	35	126	20	HDC19101	—
1½	31.8	50	180	28	HDC19102	—
1½	38.1	30	80	12	HDC19103	—
1½	38.1	60	160	25	HDC19104	—
2	50.8	40	70	11	HDC19105	—

Sheath Length		Watts	Watt Density		Part Number	
in	mm		W/in ²	W/cm ²	120V	240V
2	50.8	50	87	13	HDC19106	HDC19112
2	50.8	100	175	27	HDC19107	HDC19113
2½	63.5	50	68	11	HDC19108	—
3	76.2	60	64	10	HDC19109	—
3½	88.9	70	62	10	HDC19110	—
4	101.6	80	60	9	HDC19111	HDC19114



Note: 1/8" Diameter Hi-Density Cartridge Heaters are *made-to-order only*.
Standard lead time is 3 weeks.

Custom Engineered/Manufactured 1/8" Hi-Density Cartridge Heaters

(Refer to pages 2-2 through 2-9)

Because cartridge heaters can be very application specific, consult Tempco with your special requirements. For sizes, electrical ratings and any other design features required but not listed in the catalog, Tempco will custom engineer and manufacture to your specifications.

Consult Us with Your Requirements. We Welcome Your Inquiries.

**Custom
Manufactured**



1/8" Diameter Cartridge Heaters Termination Types

Type N External Pins with Leads (Standard Termination)

- Minimum 1/4" cold section at lead end is required
- 24 ga ultralead leads temperature rating: 482°F (250°C)
- Leads externally crimped to nickel pins
- **Standard** 10" (254 mm) leads. Specify longer leads.



Type F Internally Connected Flexible Leads

- Minimum 1/2" cold section at lead end is required
- High temperature fiberglass leads temperature rating: 842°F (450°C)
- Maximum Voltage: 120V
- **Standard** 10" (254 mm) leads. Specify longer leads.



Type M3 Teflon® End Plug Seal with Teflon® Leads

- Minimum 1/2" cold section at lead end is required
- 24 ga Teflon® insulated leads temperature rating: 392°F (200°C)
- Moisture resistant swaged Teflon® seal
- **Standard** 10" (254 mm) leads. Specify longer leads.



Type C1B SS Cable, Mechanically Fastened

- Minimum 1/4" cold section is required
- Provides maximum protection for abrasive environment
- Maximum Voltage: 120V
- **Standard** 10" (254 mm) cable over 12" (305 mm) leads. Specify longer leads or cable.



Type W SS Braid, Mechanically Fastened

- Minimum 1/4" cold section is required
- Offers sharp bending and abrasion protection
- Maximum Voltage: 120V
- **Standard** 10" (254 mm) cable over 12" (305 mm) leads. Specify longer leads or cable.



1/8" Diameter Cartridge Heaters Mounting Options

Type R4 Bent Cartridge

- Heater Sheath is bent up to 90°
- Bend is through a required cold section
- Standard sheath extension past the bend is 1"

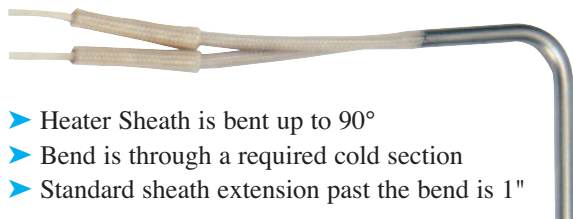

Type MFR Mounting Flange

- 1" diameter; 2 × 9/64" mounting holes are standard
- Other sizes available



Custom Terminated Multi-Purpose Use Cartridge Heaters from the Terminator Program

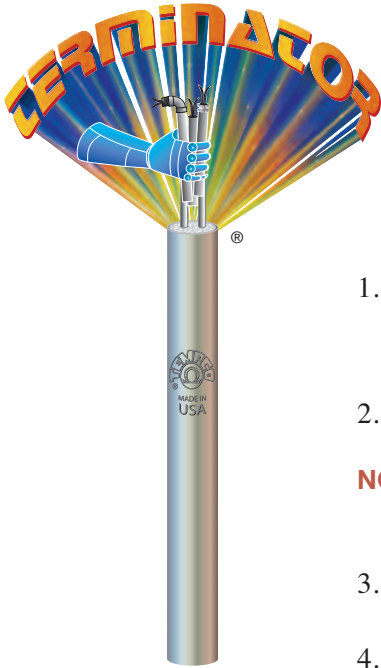

Tempco stocks over 1000 different Semi-Finished Hi-Density Cartridge Heaters in diameters 1/4", 5/16", 3/8", 1/2", 5/8" and 3/4".

These cartridge heaters are semi-finished (substrates), offering you the option to finish them by choosing from 19 program-qualified lead end terminations and options. Cartridge heaters will be ready for shipment within 1 to 3 days, depending on the termination/option selected.

Ordering Information – Follow These Simple Steps

1. Select an available 1/4" through 3/4" Hi-Density cartridge heater from the stock lists on pages 2-14 through 2-21. The Part Numbers in the tables are for heaters with termination Type N (10" long externally connected lead wires). **Call Tempco for part numbers for stock heaters with other Terminator Program terminations.**
 2. Refer to the Program-Qualified Lead Terminations Reference Photos below and on page 2-13 to select the cartridge heater termination type best suited for your application.
- NOTE:** Type "N" (10" long externally connected plain lead wires) is the most common termination applied in the Terminator program. **If a termination other than Type N is selected, a new permanent part number will be assigned when your order is placed.**
3. Specify your lead requirements in the event that the standard supplied lengths for Plain Leads (10"), Braid or Armor Cable (10" over 12" leads) are not suited for your application.
 4. Specify the Quantity.

These Program-Qualified Lead Terminations and Options for Stock Cartridge Heater Substrates will ship Same or Next Day when ordered before 2PM (CST).

Terminations

Type N

Standard Leads
(page 2-39)

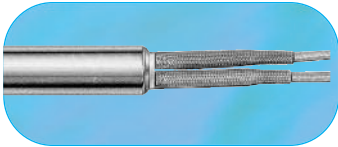

Type B

Ceramic Bead Insulation
(page 2-48)

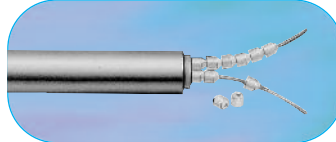

Type BL

Ceramic Bead and Leads
(page 2-48)

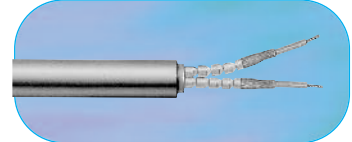

Type C1A & C1B only
Straight Armor Cable
(page 2-43)

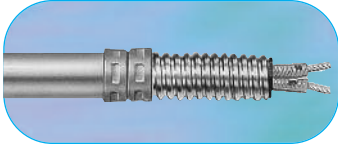

Type C2A & C2B

Right-Angle Armor
Cable with Copper Elbow
(page 2-47)

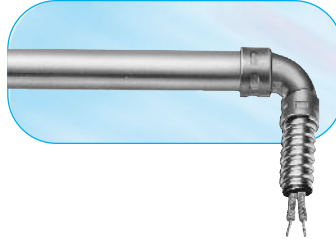

Type R1A

Right-Angle Leads with
Copper Elbow
(page 2-44)

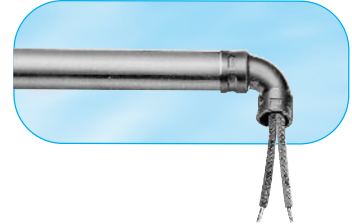

Options

Type MFR

Mounting Flange Round
(page 2-52)

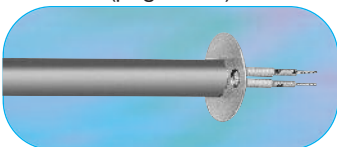

Type LR

Locating Ring
(page 2-52)



Type PS

Pull Strap
(page 2-52)



Type P

Quick Disconnect Plug
(page 2-56)

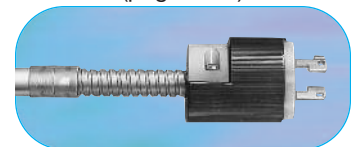

*These Program-Qualified Lead Terminations and Options
for Stock Cartridge Heater Substrates
will ship 2nd or 3rd Day when ordered before 2PM (CST).*

Terminations

Type W

Straight Wire Braided Leads
(page 2-42)

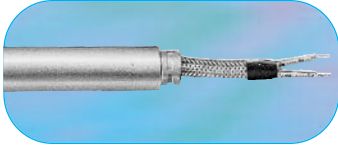

Type M2A & M2E

Potted Lead End Seal
(Cement Only)
(page 2-40)

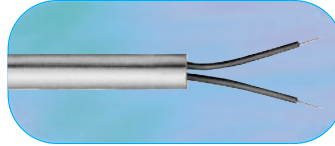

Type CMB & CMP

Single Threaded Fitting
(page 2-50)

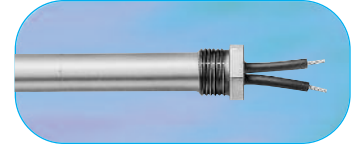

Type W1A & W1B

Right-Angle Wire
Braided Leads
(page 2-46)

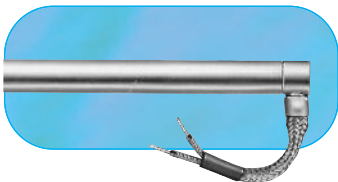

Type C3A, C3B, C3C & C3D

Right-Angle Armor Cable
(page 2-47)

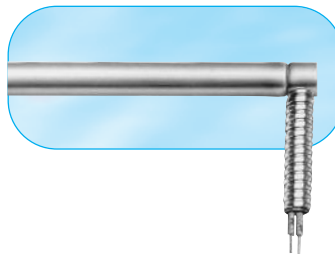

Type R2A & R2B

Right-Angle Leads
(page 2-45)



Options

Type R3

Angled Sheath Extension
(Cement Potting Only)
(page 2-53)



Type E1

General Purpose Box
(page 2-54)

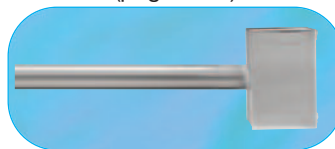

Type GL

Ground Lead Sheath
(page 2-59)



*Complete specifications and details on these terminations can be
found on the specified catalog page numbers.*

**Custom
Manufactured**



Custom Engineered/Manufactured Hi-Density Cartridge Heaters

(Refer to pages 2-2 through 2-9)

Because cartridge heaters can be very application specific, consult Tempco with your special requirements. For sizes, electrical ratings and any other design features required but not listed in the catalog, Tempco will custom engineer and manufacture to your specifications.

Consult Us with Your Requirements. We Welcome Your Inquiries.

Cartridge Heaters



Hi-Density

STOCK — Immediate Delivery through the **TERMINATOR** Lead Conversion Program



1/4" Actual .246" (6.25 mm) Diameter Hi-Density Cartridge Heaters

Part Numbers listed are for stock Cartridge Heaters terminated with 10 inch long leads (Type N Termination). Other Terminator Program terminations and options can also be applied to stock heaters (see Ordering Information).

Sheath Length		Watts	Watt Density		Part Number	
in	mm		W/in ²	W/cm ²	120V	240V
1	25.4	50	127	20	HDC00001	—
1	25.4	80	204	32	HDC00002	—
1	25.4	100	255	40	HDC00003	HDC00004
1	25.4	150	382	59	HDC00005	—
1 1/8	28.6	100	204	32	HDC00006	—
1 1/4	31.8	50	85	13	HDC00007	—
1 1/4	31.8	75	127	20	HDC00008	—
1 1/4	31.8	100	170	26	HDC00009	—
1 1/4	31.8	125	212	33	HDC00010	—
1 1/4	31.8	150	255	40	HDC00011	HDC00012
1 1/4	31.8	200	340	53	—	HDC00013
1 1/4	31.8	225	382	59	—	HDC00014
1 1/2	38.1	50	64	10	HDC00015	—
1 1/2	38.1	75	92	14	HDC08691	—
1 1/2	38.1	100	127	20	HDC00016	HDC00017
1 1/2	38.1	150	191	30	HDC00018	HDC00019
1 1/2	38.1	175	223	35	HDC00020	HDC00021
1 1/2	38.1	200	255	40	HDC00022	HDC00023
1 1/2	38.1	250	318	49	—	HDC00024
1 3/4	44.5	75	76	12	HDC00025	—
1 3/4	44.5	150	153	24	HDC00026	—
1 3/4	44.5	300	306	47	—	HDC00027
2	50.8	50	42	7	HDC00028	—
2	50.8	80	68	11	HDC00029	—
2	50.8	100	85	13	HDC00030	HDC00031
2	50.8	125	106	17	HDC00032	HDC00033
2	50.8	150	127	20	HDC00034	HDC00035
2	50.8	200	170	26	HDC00036	HDC00037
2	50.8	250	212	33	HDC00038	HDC00039
2	50.8	300	255	40	—	HDC00040
2 1/4	57.2	200	146	23	HDC10139	HDC00041
2 1/2	63.5	150	95	15	—	HDC00042
2 1/2	63.5	200	127	20	HDC00043	HDC00044
2 1/2	63.5	250	159	25	HDC00045	HDC00046
2 3/4	69.9	200	113	18	—	HDC00048
3	76.2	75	38	6	HDC00049	—
3	76.2	100	51	8	HDC00050	HDC00051
3	76.2	125	64	10	—	HDC00052
3	76.2	150	76	12	HDC00053	HDC00054
3	76.2	200	102	16	HDC00055	HDC00056

Sheath Length		Watts	Watt Density		Part Number	
in	mm		W/in ²	W/cm ²	120V	240V
3	76.2	250	127	20	HDC00057	HDC00058
3	76.2	300	153	24	HDC00059	HDC00060
3	76.2	350	178	28	—	HDC00061
3 1/2	88.9	200	85	13	—	HDC00062
3 1/2	88.9	300	127	20	HDC00063	HDC00064
3 3/4	95.3	300	118	18	—	HDC00065
4	101.6	100	36	6	HDC00066	—
4	101.6	150	55	9	HDC00067	—
4	101.6	175	64	10	HDC00068	HDC00069
4	101.6	200	73	11	HDC00070	HDC00071
4	101.6	250	91	14	HDC00072	HDC00073
4	101.6	300	109	17	HDC00074	HDC00075
4	101.6	400	146	23	—	HDC00076
4 1/2	114.3	125	40	6	HDC00077	—
4 1/2	114.3	200	64	10	HDC00078	—
4 1/2	114.3	500	159	25	—	HDC00079
5	127.0	200	57	9	—	HDC00080
5	127.0	250	71	11	—	HDC00081
5	127.0	300	87	14	HDC22940	—
5	127.0	350	99	15	HDC00082	HDC00083
5	127.0	400	113	18	HDC00084	HDC00085
5 3/4	146.1	350	85	13	HDC00086	HDC00087
6	152.4	150	35	5	HDC00088	—
6	152.4	200	46	7	—	HDC00089
6	152.4	300	69	11	HDC00090	HDC00091
6	152.4	400	93	14	HDC00092	HDC00093
6	152.4	450	104	16	HDC00094	HDC00095
6	152.4	600	139	22	—	HDC00096
6 1/2	165.1	500	106	17	HDC00097	HDC00098
7	177.8	500	98	15	HDC20502	—
7	177.8	600	118	18	—	HDC00099
7 1/2	190.5	525	95	15	HDC00100	—
8	203.2	300	51	8	HDC00101	—
8	203.2	600	102	16	—	HDC00102
9	228.6	675	101	16	—	HDC00103
9 1/2	241.3	525	74	12	HDC00104	—
10	254.0	750	101	16	—	HDC00105
11	279.4	600	73	11	—	HDC00106
13	330.2	725	74	12	—	HDC00107

Ordering Information

Order by Part Number for stock Cartridge heaters with Type N termination. Call Tempco for part numbers for stock heaters with other Terminator Program terminations and options (see pages 2-12 & 2-13).

Custom Engineered/Manufactured

Cartridge Heaters can be application specific; therefore for sizes, electrical ratings, terminations and any other design features not listed in this catalog **TEMPCO** will custom manufacture to your specifications. Consult us with your requirements.

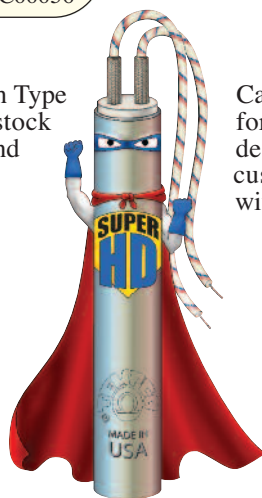

STOCK — Immediate Delivery through the  Lead Conversion Program

5/16" Actual .308" (7.82 mm) Diameter Hi-Density Cartridge Heaters

Part Numbers listed are for stock Cartridge Heaters terminated with 10 inch long leads (Type N Termination). Other Terminator Program terminations and options can also be applied to stock heaters (see Ordering Information).

Sheath Length		Watts	Watt Density		Part Number	
in	mm		W/in ²	W/cm ²	120V	240V
2	50.8	150	102	16	HDC00108	—
2½	63.5	150	76	12	HDC00109	—
2½	63.5	200	102	16	HDC00110	HDC00111
3	76.2	225	92	14	HDC00112	HDC00113
3¾	85.7	160	57	9	HDC00114	—
3½	88.9	250	85	13	HDC00115	—

3/8" Actual .371" (9.42 mm) Diameter Hi-Density Cartridge Heaters

Part Numbers listed are for stock Cartridge Heaters terminated with 10 inch long leads (Type N Termination). Other Terminator Program terminations and options can also be applied to stock heaters (see Ordering Information).

Sheath Length		Watts	Watt Density		Part Number	
in	mm		W/in ²	W/cm ²	120V	240V
1	25.4	50	85	13	HDC00125	—
1	25.4	100	170	26	HDC00127	—
1	25.4	150	255	40	HDC00128	HDC00129
1	25.4	200	340	53	—	HDC00130
1¼	31.8	100	113	18	HDC00133	—
1¼	31.8	150	170	26	HDC00135	HDC00136
1¼	31.8	200	226	35	HDC00137	HDC00138
1½	33.3	100	104	16	HDC00139	HDC00140
1½	33.3	150	157	24	HDC00141	—
1½	34.9	150	146	23	HDC00142	HDC00143
1½	36.5	100	91	14	HDC00144	—
1½	38.1	30	25	4	HDC00146	—
1½	38.1	50	42	7	HDC00147	HDC00148
1½	38.1	75	64	10	HDC00149	—
1½	38.1	100	85	13	HDC00150	HDC00151
1½	38.1	125	106	17	—	HDC00152
1½	38.1	150	127	20	HDC00153	HDC00154
1½	38.1	200	170	26	HDC00155	HDC00156
1½	38.1	250	212	33	HDC00157	HDC00158
1¾	44.5	150	102	16	HDC00160	HDC00161
1¾	44.5	200	136	21	—	HDC00163
1¾	44.5	250	170	26	HDC00164	HDC00165
1¾	46.0	150	97	15	—	HDC00166
1¾	46.0	200	129	20	HDC00167	—
1¾	47.6	250	154	24	HDC00169	—
2	50.8	50	28	4	HDC00170	—
2	50.8	75	42	7	HDC00171	—
2	50.8	100	57	9	HDC00172	HDC00173
2	50.8	125	71	11	HDC00174	—
2	50.8	150	85	13	HDC00175	HDC00176
2	50.8	200	113	18	HDC00177	HDC00178
2	50.8	250	141	22	HDC00179	HDC00180
2	50.8	300	170	26	HDC00181	HDC00182
2	50.8	350	198	31	—	HDC00183
2	50.8	400	226	35	HDC00184	HDC00185
2	50.8	500	283	44	HDC00186	HDC00187
2¼	57.2	75	36	6	HDC00189	—
2¼	57.2	100	49	8	HDC00190	—
2¼	57.2	125	61	9	HDC00191	HDC00192
2¼	57.2	150	73	11	—	HDC00193
2¼	57.2	175	85	13	HDC00194	—
2¼	57.2	200	97	15	—	HDC00196
2¼	57.2	250	125	19	HDC00197	—
2¼	57.2	300	146	23	HDC00199	HDC00200

Sheath Length		Watts	Watt Density		Part Number	
in	mm		W/in ²	W/cm ²	120V	240V
2¼	57.2	350	170	26	HDC00201	HDC00202
2¼	57.2	400	194	30	—	HDC00204
2¼	57.2	500	243	38	—	HDC00205
2½	60.3	75	34	5	HDC00206	—
2½	60.3	165	75	12	—	HDC00207
2½	60.3	300	136	21	—	HDC00210
2½	63.5	100	42	7	HDC00213	HDC00214
2½	63.5	125	53	8	HDC00215	—
2½	63.5	150	64	10	—	HDC00216
2½	63.5	200	85	13	HDC00217	HDC00218
2½	63.5	250	106	17	HDC00219	HDC00220
2½	63.5	300	127	20	HDC00221	HDC00222
2½	63.5	350	149	23	—	HDC00223
2½	63.5	400	174	27	HDC00224	—
2½	63.5	500	212	33	HDC00227	HDC00228
2¾	69.9	400	151	23	—	HDC00231
2¾	71.4	300	110	17	—	HDC00235
3	76.2	100	34	5	HDC00236	HDC00237
3	76.2	125	42	7	HDC00238	—
3	76.2	150	51	8	HDC00239	—
3	76.2	200	68	11	—	HDC00241
3	76.2	250	85	13	HDC00242	HDC00243
3	76.2	300	102	16	HDC00244	HDC00245
3	76.2	375	127	20	HDC00247	—
3	76.2	400	136	21	HDC00249	HDC00250
3	76.2	500	170	26	HDC00251	HDC00252
3	76.2	600	204	32	—	HDC00253
3	76.2	750	255	40	—	HDC00254
3¾	84.1	500	151	23	HDC00255	—
3½	88.9	125	35	6	HDC00256	—
3½	88.9	200	57	9	—	HDC00257
3½	88.9	225	64	10	—	HDC00258
3½	88.9	250	71	11	HDC00259	HDC00260
3½	88.9	300	85	13	HDC00261	HDC00262
3½	88.9	350	99	15	HDC00263	HDC00264
3½	88.9	400	113	18	—	HDC00265
3½	88.9	500	141	22	HDC00266	HDC00267
3¾	96.8	150	38	6	HDC00269	—
3¾	96.8	500	128	20	—	HDC00270
4	101.6	100	24	4	HDC00272	—
4	101.6	125	30	5	HDC00273	HDC00274
4	101.6	150	36	6	HDC00275	—
4	101.6	175	42	7	HDC00276	—
4	101.6	200	49	8	HDC00277	HDC00278

Cartridge Heaters



Hi-Density

STOCK — Immediate Delivery through the **TERMINATOR** Lead Conversion Program



Continued from previous page...

3/8" Actual .371" (9.42 mm) Diameter Hi-Density Cartridge Heaters

Part Numbers listed are for stock Cartridge Heaters terminated with 10 inch long leads (Type N Termination).
Other Terminator Program terminations and options can also be applied to stock heaters (see Ordering Information).

Sheath Length		Watts	Watt Density		Part Number	
in	mm		W/in ²	W/cm ²	120V	240V
4	101.6	250	61	9	HDC00279	HDC00280
4	101.6	300	73	11	HDC00281	HDC00282
4	101.6	350	85	13	HDC00283	HDC00284
4	101.6	400	97	15	HDC00285	HDC00286
4	101.6	450	109	17	—	HDC00288
4	101.6	500	121	19	HDC00289	HDC00290
4	101.6	600	146	23	—	HDC00292
4	101.6	700	170	26	—	HDC00293
4	101.6	750	182	28	—	HDC00294
4 1/4	108.0	300	68	11	—	HDC00295
4 1/4	108.0	750	170	26	—	HDC00296
4 1/2	114.3	250	53	8	—	HDC00297
4 1/2	114.3	300	64	10	HDC00298	HDC00299
4 1/2	114.3	450	95	15	HDC00302	HDC00303
4 1/2	114.3	500	106	17	HDC00304	HDC00305
4 1/2	120.7	300	60	9	—	HDC00307
4 13/16	122.2	300	59	9	—	HDC00308
4 13/16	122.2	500	98	15	—	HDC00309
5	127.0	150	28	4	HDC00312	HDC00313
5	127.0	200	38	6	HDC00314	HDC00315
5	127.0	250	47	7	HDC00316	—
5	127.0	300	57	9	HDC00317	HDC00318
5	127.0	350	66	10	—	HDC00319
5	127.0	400	75	12	HDC00320	HDC00321
5	127.0	500	94	15	HDC00323	HDC00324
5	127.0	600	113	18	—	HDC00327
5	127.0	700	132	21	—	HDC00328
5	127.0	750	141	22	—	HDC00329
5	127.0	800	151	23	—	HDC00330
5	127.0	1000	189	29	—	HDC00331
5 1/4	133.3	200	36	6	—	HDC00332
5 1/2	139.7	250	42	7	HDC00334	HDC00335
5 1/2	139.7	550	93	15	—	HDC00338
5 1/2	139.7	600	102	16	—	HDC00339
5 1/2	139.7	1000	170	26	—	HDC00340
5 3/4	146.1	400	65	10	—	HDC00341
5 3/4	146.1	600	97	15	HDC00342	HDC00343
6	152.4	200	31	5	HDC00344	—
6	152.4	250	39	6	HDC00345	HDC00346
6	152.4	300	46	7	HDC00347	HDC00348
6	152.4	400	62	10	HDC00349	HDC00350
6	152.4	500	77	12	HDC00351	HDC00352
6	152.4	600	93	14	HDC00353	HDC00354
6	152.4	675	104	16	—	HDC00355
6	152.4	750	116	18	HDC00356	HDC00357
6	152.4	800	123	19	—	HDC00358
6	152.4	900	139	22	—	HDC00359
6	152.4	1000	154	24	—	HDC00360
6 1/2	165.1	600	85	13	—	HDC00361
6 1/2	165.1	1000	141	22	—	HDC00362
7	177.8	250	33	5	HDC00365	HDC00366
7	177.8	350	46	7	—	HDC00367

Sheath Length		Watts	Watt Density		Part Number	
in	mm		W/in ²	W/cm ²	120V	240V
7	177.8	400	52	8	HDC00368	—
7	177.8	500	65	10	—	HDC00369
7	177.8	600	78	12	HDC00370	HDC00371
7	177.8	750	98	15	—	HDC00373
7	177.8	775	101	16	—	HDC00374
7	177.8	1000	131	20	—	HDC00375
7 1/2	190.5	600	73	11	—	HDC00377
7 1/2	190.5	725	88	14	—	HDC00378
7 1/2	190.5	850	103	16	—	HDC00379
7 1/2	190.5	1000	121	19	—	HDC00380
7 13/16	198.4	750	87	14	—	HDC00381
8	203.2	250	30	5	HDC07944	—
8	203.2	300	34	5	HDC00382	HDC00383
8	203.2	400	45	7	HDC00384	—
8	203.2	450	51	8	HDC00385	—
8	203.2	500	57	9	HDC00386	HDC00387
8	203.2	600	68	11	HDC00388	HDC00389
8	203.2	700	79	12	—	HDC00390
8	203.2	750	85	13	—	HDC00391
8	203.2	900	102	16	—	HDC00392
8	203.2	1000	113	18	—	HDC00393
8 3/8	219.1	500	52	8	—	HDC00395
9	228.6	200	20	3	HDC00396	HDC00397
9	228.6	500	50	8	—	HDC00398
9	228.6	885	88	14	—	HDC00399
9	228.6	1000	100	16	—	HDC00400
9 1/2	241.3	200	19	3	HDC00401	—
9 1/2	241.3	600	57	9	—	HDC00402
9 1/2	241.3	1000	94	15	—	HDC00403
10	254.0	400	36	5	HDC00405	—
10	254.0	500	45	7	—	HDC00407
10	254.0	600	54	8	HDC00408	HDC00409
10	254.0	700	63	10	—	HDC00410
10	254.0	750	67	10	—	HDC00411
10	254.0	1000	89	14	—	HDC00413
10	254.0	1500	134	21	—	HDC00415
10 13/16	274.6	375	31	5	—	HDC00416
12	304.8	400	30	5	HDC00417	—
12	304.8	500	37	6	—	HDC00418
12	304.8	600	44	7	HDC00419	HDC00420
12	304.8	750	57	9	—	HDC14222
12	304.8	1000	74	11	—	HDC00421
12	304.8	1500	113	18	—	HDC06225
12 13/16	325.4	1000	69	11	—	HDC00422
13	330.2	1000	70	11	—	HDC07200
14	355.6	600	39	6	—	HDC22941
14	355.6	750	47	7	—	HDC00423
16	406.4	600	34	5	—	HDC22942
16	406.4	1200	66	10	—	HDC00424
18	457.2	1000	58	9	—	HDC22943
20	508.0	1000	53	8	—	HDC09305
24	609.6	1000	38	6	—	HDC10234

Ordering Information

Order by Part Number for stock Cartridge heaters with Type N termination. Call Tempco for part numbers for stock heaters with other Terminator Program terminations and options (see pages 2-12 & 2-13).

Custom Engineered/Manufactured

Cartridge Heaters can be application specific; therefore for sizes, electrical ratings, terminations and any other design features not listed in this catalog **TEMPCO** will custom manufacture to your specifications. Consult us with your requirements.

[View Product Inventory @ www.tempco.com](http://www.tempco.com)

STOCK — Immediate Delivery through the **TERMINATOR** Lead Conversion Program

1/2" Actual .496" (12.60 mm) Diameter Hi-Density Cartridge Heaters

Part Numbers listed are for stock Cartridge Heaters terminated with 10 inch long leads (Type N Termination).
Other Terminator Program terminations and options can also be applied to stock heaters (see Ordering Information).

Sheath Length		Watts	Watt Density		Part Number	
in	mm		W/in ²	W/cm ²	120V	240V
1	25.4	50	64	10	HDC00426	—
1	25.4	150	191	30	HDC00427	—
1	25.4	200	255	40	—	HDC00428
1¼	31.8	50	42	7	HDC00429	—
1¼	31.8	125	106	17	HDC00430	HDC00431
1¼	31.8	180	153	24	—	HDC00432
1¼	31.8	200	170	26	—	HDC00433
1¼	31.8	250	212	33	—	HDC00434
1½	38.1	50	32	5	HDC00435	—
1½	38.1	150	95	15	HDC00436	HDC00437
1½	38.1	200	127	20	HDC00438	HDC00439
1¾	44.5	100	51	8	HDC00440	—
1¾	44.5	200	102	16	—	HDC00441
1¾	44.5	250	127	20	HDC00442	—
1¾	44.5	400	204	32	—	HDC00443
2	50.8	75	32	5	HDC00444	—
2	50.8	100	52	8	—	HDC22944
2	50.8	150	64	10	HDC00445	—
2	50.8	175	74	12	HDC00446	—
2	50.8	200	85	13	HDC00447	HDC00448
2	50.8	250	106	17	HDC00449	HDC00450
2	50.8	300	127	20	HDC00451	HDC00452
2	50.8	400	170	26	HDC00453	HDC00454
2	50.8	500	212	33	HDC00455	—
2	50.8	600	255	40	—	HDC00456
2	50.8	700	297	46	—	HDC00457
2¼	57.2	75	27	4	HDC00458	—
2¼	57.2	100	36	6	HDC00459	—
2¼	57.2	125	45	7	HDC00460	—
2¼	57.2	150	55	9	HDC00461	—
2¼	57.2	250	91	14	HDC00462	HDC00463
2¼	57.2	300	109	17	—	HDC00464
2¼	57.2	400	146	23	HDC00465	HDC00466
2¼	57.2	500	182	28	HDC00467	HDC00468
2½	60.3	100	34	5	HDC00470	HDC00471
2½	60.3	125	42	7	HDC00472	—
2½	60.3	250	85	13	HDC00473	HDC00474
2½	60.3	400	136	21	—	HDC00475
2½	60.3	500	170	26	HDC00476	HDC00477
2½	60.3	100	32	5	HDC00478	HDC00479
2½	63.5	125	40	6	HDC00480	—
2½	63.5	150	48	7	—	HDC00481
2½	63.5	200	64	10	HDC00482	HDC00483
2½	63.5	250	80	12	HDC00484	HDC00485
2½	63.5	300	95	15	HDC00486	HDC00487
2½	63.5	400	127	20	HDC00489	HDC00490
2½	63.5	500	159	25	HDC00491	HDC00492
2½	63.5	300	93	14	—	HDC00493
2¾	65.1	350	108	17	HDC00494	—
2¾	69.9	250	71	11	HDC00495	—
2¾	69.9	400	113	18	HDC00496	HDC00497
3	76.2	125	32	5	HDC00498	HDC00499
3	76.2	150	38	6	HDC00500	HDC00501
3	76.2	200	51	8	—	HDC00502
3	76.2	250	64	10	HDC00503	HDC00504
3	76.2	300	76	12	HDC00505	HDC00506
3	76.2	350	89	14	HDC00507	—
3	76.2	400	102	16	HDC00508	HDC00509

Sheath Length		Watts	Watt Density		Part Number	
in	mm		W/in ²	W/cm ²	120V	240V
3	76.2	500	127	20	HDC00510	HDC00511
3	76.2	600	153	24	HDC00512	HDC00513
3	76.2	750	191	30	HDC00514	HDC00515
3	76.2	1000	255	40	HDC00516	—
3½	88.9	250	53	8	HDC00517	HDC00518
3½	88.9	300	64	10	—	HDC00519
3½	88.9	350	74	12	—	HDC00520
3½	88.9	400	95	15	—	HDC08472
3½	88.9	500	106	17	HDC00522	HDC00523
3½	88.9	750	159	25	—	HDC00524
3½	88.9	1000	212	33	—	HDC00525
3¾	95.3	500	98	15	—	HDC00526
3⅞	96.8	250	48	8	—	HDC00527
3⅞	96.8	500	96	15	HDC00528	—
4	101.6	150	27	4	HDC00529	HDC00530
4	101.6	200	40	6	—	HDC07555
4	101.6	250	45	7	HDC00531	HDC00532
4	101.6	300	55	9	HDC00533	HDC00534
4	101.6	350	64	10	HDC00536	HDC00537
4	101.6	400	73	11	HDC00538	HDC00539
4	101.6	500	91	14	HDC00540	HDC00541
4	101.6	550	100	16	HDC00542	HDC00543
4	101.6	600	109	17	—	HDC00544
4	101.6	750	136	21	HDC00545	HDC00546
4	101.6	1000	182	28	—	HDC00547
4	101.6	1200	218	34	—	HDC00548
4½	109.5	550	92	14	HDC00550	—
4½	114.3	250	40	6	HDC00551	—
4½	114.3	350	56	9	—	HDC00552
4½	114.3	500	80	12	HDC00553	HDC00554
4½	114.3	650	103	16	HDC00555	HDC00556
4½	114.3	750	119	19	HDC00557	HDC00558
4½	114.3	1000	159	25	—	HDC00559
4¾	120.7	200	30	5	—	HDC00560
4⅞	122.2	250	37	6	HDC00561	—
4⅞	122.2	300	44	7	—	HDC00562
4⅞	122.2	1000	148	23	—	HDC00563
5	127.0	200	28	4	HDC00565	HDC00566
5	127.0	250	35	6	HDC00567	—
5	127.0	300	42	7	—	HDC00568
5	127.0	350	50	8	HDC00569	HDC00570
5	127.0	400	57	9	HDC00571	HDC00572
5	127.0	500	71	11	HDC00573	HDC00574
5	127.0	550	78	12	—	HDC00575
5	127.0	600	85	13	—	HDC00576
5	127.0	625	88	14	—	HDC00577
5	127.0	750	106	17	HDC00578	HDC00579
5	127.0	800	113	18	—	HDC00580
5	127.0	1000	141	22	—	HDC00581
5¼	133.4	250	34	5	HDC00582	HDC00583
5¼	133.4	1000	134	21	—	HDC00584
5½	139.7	200	25	4	—	HDC00585
5½	139.7	500	64	10	HDC00586	HDC00587
5½	139.7	650	83	13	—	HDC00588
5½	139.7	750	95	15	HDC00589	HDC00590
5¾	146.1	350	42	7	—	HDC00591
5¾	146.1	700	85	13	HDC00592	HDC00593
5⅞	147.6	300	36	6	—	HDC00594

Cartridge Heaters



Hi-Density

STOCK — Immediate Delivery through the **TERMINATOR** Lead Conversion Program



Continued from previous page...

1/2" Actual .496" (12.60 mm) Diameter Hi-Density Cartridge Heaters

Part Numbers listed are for stock Cartridge Heaters terminated with 10 inch long leads (Type N Termination). Other Terminator Program terminations and options can also be applied to stock heaters (see Ordering Information).

Sheath Length		Watts	Watt Density		Part Number	
in	mm		W/in ²	W/cm ²	120V	240V
6	152.4	200	23	4	—	HDC00595
6	152.4	250	29	5	HDC00596	HDC00597
6	152.4	300	35	5	HDC00598	HDC00599
6	152.4	350	41	6	HDC00600	HDC00601
6	152.4	450	52	8	—	HDC00602
6	152.4	500	58	9	HDC00603	HDC00604
6	152.4	600	69	11	—	HDC00605
6	152.4	750	87	14	HDC00606	HDC00607
6	152.4	850	98	15	HDC00609	HDC00610
6	152.4	875	101	16	—	HDC00611
6	152.4	1000	116	18	HDC00612	HDC00613
6	152.4	1200	139	22	—	HDC00614
6	152.4	1500	183	28	—	HDC16228
6 3/8	161.9	1000	108	17	—	HDC00615
6 1/2	165.1	500	53	8	HDC00616	HDC00617
6 1/2	165.1	1000	106	17	—	HDC00618
6 3/4	171.5	500	51	8	HDC00619	HDC00620
7	177.8	250	24	4	HDC00621	—
7	177.8	340	33	5	—	HDC00622
7	177.8	400	39	6	—	HDC00623
7	177.8	500	49	8	HDC00624	HDC00625
7	177.8	600	59	9	HDC00626	HDC00627
7	177.8	700	69	11	—	HDC00628
7	177.8	750	73	11	HDC00629	HDC00630
7	177.8	1000	98	15	HDC00631	HDC00632
7	177.8	1500	147	23	—	HDC00633
7 1/2	190.5	500	45	7	HDC00634	HDC00635
7 1/2	190.5	1000	91	14	—	HDC00636
7 3/4	196.9	1000	88	14	—	HDC00637
8	203.2	200	17	3	—	HDC00639
8	203.2	300	25	4	HDC00640	HDC00641
8	203.2	500	42	7	HDC00642	HDC00643
8	203.2	600	51	8	—	HDC00644
8	203.2	750	64	10	HDC00645	HDC00646
8	203.2	800	68	11	HDC00647	HDC00648
8	203.2	1000	85	13	HDC00650	HDC00651
8	203.2	1200	102	16	—	HDC00653
8	203.2	1500	127	20	—	HDC00654
8	203.2	2000	170	26	—	HDC00655
8 1/2	215.9	300	24	4	—	HDC00656
8 1/2	215.9	500	40	6	—	HDC00657
8 1/2	215.9	1000	80	12	HDC00658	HDC00659
8 3/4	222.3	1000	77	12	—	HDC00660
9	228.6	500	37	6	—	HDC00661
9	228.6	750	56	9	—	HDC00662
9	228.6	1000	75	12	HDC00663	HDC00664

Sheath Length		Watts	Watt Density		Part Number	
in	mm		W/in ²	W/cm ²	120V	240V
9	228.6	1325	99	15	—	HDC00665
9	228.6	1500	112	17	—	HDC00666
9 1/2	241.3	500	35	6	—	HDC00667
9 1/2	241.3	800	57	9	—	HDC00668
9 1/2	241.3	1000	71	11	—	HDC00669
10	254.0	500	34	5	HDC00670	HDC00671
10	254.0	750	50	8	—	HDC00672
10	254.0	800	54	8	—	HDC00673
10	254.0	1000	67	10	HDC00674	HDC00675
10	254.0	1250	84	13	—	HDC00677
10	254.0	1500	101	16	—	HDC00678
10	254.0	2000	134	21	—	HDC00679
10 1/2	266.7	1500	95	15	—	HDC00680
11	279.4	500	30	5	HDC00681	—
11	279.4	1000	61	9	—	HDC00682
11	279.4	1500	91	14	—	HDC00683
11	279.4	2000	121	19	—	HDC00684
11 1/2	292.1	1525	88	14	—	HDC00685
12	304.8	500	28	4	HDC00686	HDC00687
12	304.8	600	33	5	HDC00688	HDC00689
12	304.8	1000	55	9	HDC00690	HDC00691
12	304.8	1100	61	9	—	HDC00692
12	304.8	1500	83	13	—	HDC00693
12	304.8	2000	111	17	—	HDC00694
12 1/2	317.5	1675	89	14	—	HDC00695
13 1/2	342.9	500	24	4	—	HDC00696
14	355.6	1000	47	7	—	HDC00697
14	355.6	1700	80	12	—	HDC00698
14	355.6	2300	108	17	—	HDC00699
15	381.0	800	35	5	—	HDC00700
15	381.0	1000	44	7	—	HDC00701
15	381.0	1500	66	10	—	HDC00702
15	381.0	2000	88	14	—	HDC00703
16	406.4	800	33	5	—	HDC00704
16	406.4	1000	41	6	—	HDC00705
16	406.4	2000	84	13	—	HDC17207
16 1/2	419.1	2200	88	14	—	HDC00706
17	431.8	1000	39	6	—	HDC00707
18	457.2	750	27	4	—	HDC00708
18	457.2	1000	36	6	—	HDC00709
18	457.2	1500	55	9	—	HDC00710
18	457.2	1700	62	10	—	HDC00711
18	457.2	2000	73	11	—	HDC00712
20	508.0	1000	34	5	—	HDC11652
24	609.6	1000	28	4	—	HDC14867

Ordering Information

Order by Part Number for stock Cartridge heaters with Type N termination. Call Tempco for part numbers for stock heaters with other Terminator Program terminations and options (see pages 2-12 & 2-13).

Custom Engineered/Manufactured

Cartridge Heaters can be application specific; therefore for sizes, electrical ratings, terminations and any other design features not listed in this catalog **TEMPCO** will custom manufacture to your specifications. Consult us with your requirements.

STOCK — Immediate Delivery through the **TERMINATOR** Lead Conversion Program

5/8" Actual .621" (15.77 mm) Diameter Hi-Density Cartridge Heaters

Part Numbers listed are for stock Cartridge Heaters terminated with 10 inch long leads (Type N Termination). Other Terminator Program terminations and options can also be applied to stock heaters (see Ordering Information).

Sheath Length		Watts	Watt Density		Part Number	
in	mm		W/in ²	W/cm ²	120V	240V
1¼	31.8	50	34	5	HDC00713	—
1¼	31.8	200	136	21	HDC00714	HDC00715
1¼	31.8	250	170	26	HDC00716	HDC00717
1½	38.1	250	127	20	HDC00719	HDC00720
2	50.8	100	34	5	HDC00721	—
2	50.8	125	42	7	HDC00722	—
2	50.8	200	68	11	HDC00723	HDC00724
2	50.8	250	85	13	HDC00725	HDC00726
2	50.8	300	102	16	—	HDC00727
2	50.8	400	136	21	—	HDC00728
2	50.8	500	170	26	—	HDC00729
2	50.8	750	255	40	—	HDC00730
2¼	57.2	100	29	5	HDC00731	—
2¼	57.2	125	36	6	HDC00732	—
2¼	57.2	250	73	11	HDC00733	HDC00734
2¼	57.2	350	102	16	HDC00735	HDC00736
2½	60.3	280	76	12	HDC00739	HDC00740
2½	63.5	180	46	7	HDC00742	—
2½	63.5	275	70	11	HDC00743	HDC00744
2½	63.5	400	102	16	HDC00745	HDC00746
2½	63.5	720	183	28	—	HDC00747
3	76.2	150	31	5	HDC00748	—
3	76.2	180	37	6	HDC00749	—
3	76.2	250	51	8	HDC00750	HDC00751
3	76.2	350	71	11	HDC00752	HDC00753
3	76.2	400	81	13	HDC00754	—
3	76.2	500	102	16	HDC00755	HDC00756
3	76.2	600	122	19	—	HDC00757
3	76.2	720	147	23	—	HDC00758
3	76.2	750	153	24	—	HDC00759
3¼	82.6	200	37	6	HDC00760	—
3¼	82.6	800	148	23	—	HDC00761
3½	88.9	525	89	14	—	HDC00762
3¾	95.3	525	82	13	HDC00763	HDC00764
4	101.6	250	36	6	HDC00766	HDC00767
4	101.6	300	44	7	—	HDC00768
4	101.6	350	51	8	HDC00769	—
4	101.6	400	58	9	—	HDC00770
4	101.6	500	73	11	HDC00771	HDC00772
4	101.6	550	80	12	—	HDC00773
4	101.6	600	87	14	—	HDC00774
4	101.6	750	109	17	HDC00775	HDC00776
4	101.6	1000	146	23	—	HDC00777
4½	114.3	500	64	10	—	HDC00780
4½	114.3	750	95	15	HDC00783	HDC00784
4½	114.3	1000	127	20	—	HDC00785
4¾	120.7	750	90	14	—	HDC00787
5	127.0	250	28	4	HDC00788	HDC00789
5	127.0	500	57	9	—	HDC00790
5	127.0	750	85	13	HDC00791	HDC00792
5	127.0	875	99	15	—	HDC00793
5	127.0	1000	113	18	HDC00794	HDC00795
5¾	136.5	800	84	13	HDC00796	HDC00797
5½	139.7	800	81	13	—	HDC00800
5¾	146.1	500	49	8	—	HDC00801
5¾	146.1	1500	146	23	—	HDC00802

Sheath Length		Watts	Watt Density		Part Number	
in	mm		W/in ²	W/cm ²	120V	240V
6	152.4	300	28	4	HDC00804	HDC00805
6	152.4	500	46	7	HDC00806	HDC00807
6	152.4	750	69	11	—	HDC00808
6	152.4	1000	93	14	HDC00809	HDC00810
6	152.4	1200	111	17	—	HDC00811
6	152.4	1500	139	22	HDC00812	HDC00813
6½	165.1	350	30	5	HDC00814	HDC00815
6½	165.1	500	42	7	HDC00816	HDC00817
6½	165.1	900	76	12	—	HDC00818
6½	165.1	1400	119	18	—	HDC00819
6¾	171.5	500	41	6	—	HDC00820
6¾	171.5	1000	81	13	—	HDC00821
7	177.8	500	39	6	HDC00822	HDC00823
7	177.8	750	59	9	—	HDC00824
7	177.8	1000	78	12	HDC00825	HDC00826
7	177.8	1500	118	18	—	HDC00827
7½	190.5	325	24	4	HDC00828	—
7½	190.5	1300	95	15	—	HDC00829
7¾	196.9	400	28	4	—	HDC00830
7¾	196.9	1000	70	11	—	HDC00831
8	203.2	400	27	4	—	HDC00832
8	203.2	500	34	5	HDC00833	HDC00834
8	203.2	750	51	8	—	HDC00835
8	203.2	850	58	9	—	HDC00836
8	203.2	1000	68	11	HDC00837	HDC00838
8	203.2	1200	81	13	HDC00839	HDC00840
8	203.2	1500	102	16	HDC00841	HDC00842
8	203.2	2000	136	21	—	HDC00843
8¾	222.3	450	28	4	HDC00845	—
8¾	222.3	1800	111	17	—	HDC00846
9	228.6	500	30	5	—	HDC00847
9	228.6	750	45	7	—	HDC00848
9	228.6	1000	60	9	—	HDC00849
9	228.6	1500	90	14	—	HDC00850
9½	241.3	975	55	9	—	HDC00851
10	254.0	500	27	4	HDC00852	HDC00853
10	254.0	650	35	5	HDC00855	—
10	254.0	750	40	6	—	HDC00856
10	254.0	800	43	7	—	HDC00857
10	254.0	1000	54	8	HDC00858	HDC00859
10	254.0	1500	80	13	HDC00860	HDC00861
10	254.0	2000	107	17	—	HDC00862
11	279.4	1000	49	8	—	HDC00863
11	279.4	1400	68	11	—	HDC00864
11	279.4	2000	97	15	—	HDC00865
12	304.8	500	22	3	HDC00866	HDC00867
12	304.8	600	27	4	HDC00868	—
12	304.8	775	34	5	—	HDC00869
12	304.8	900	40	6	—	HDC00870
12	304.8	1000	44	7	HDC00871	HDC00872
12	304.8	1500	66	10	HDC00873	HDC00874
12	304.8	2000	89	14	—	HDC00875
13	330.2	1000	41	6	—	HDC00876
13	330.2	1500	61	10	—	HDC00877
14	355.6	925	35	5	HDC00878	—
14	355.6	1000	38	6	—	HDC00879

Cartridge Heaters



Hi-Density

STOCK — Immediate Delivery through the **TERMINATOR** Lead Conversion Program



Continued from previous page...

5/8" Actual .621" (15.77 mm) Diameter Hi-Density Cartridge Heaters

Part Numbers listed are for stock Cartridge Heaters terminated with 10 inch long leads (Type N Termination). Other Terminator Program terminations and options can also be applied to stock heaters (see Ordering Information).

Sheath Length		Watts	Watt Density		Part Number	
in	mm		W/in ²	W/cm ²	120V	240V
14	355.6	1500	57	9	—	HDC00880
14	355.6	3700	140	22	—	HDC00881
15	381.0	750	26	4	—	HDC00882
15	381.0	1000	35	5	—	HDC00883
15	381.0	2400	84	13	—	HDC00884
15	381.0	4000	140	22	—	HDC00885
16	406.4	1000	33	5	—	HDC00886
16	406.4	2500	82	13	—	HDC00887
16	406.4	4500	148	23	—	HDC00888
17	431.8	1000	31	5	—	HDC00889
18	457.2	900	26	4	—	HDC00890
18	457.2	1000	29	5	—	HDC00891
18	457.2	1500	44	7	—	HDC00892

Sheath Length		Watts	Watt Density		Part Number	
in	mm		W/in ²	W/cm ²	120V	240V
18	457.2	3000	87	14	—	HDC00893
18	457.2	4700	137	21	—	HDC00894
19	482.6	1000	28	4	—	HDC00895
20	508.0	1000	26	4	—	HDC00896
20	508.0	1500	39	6	—	HDC00897
20	508.0	3500	91	14	—	HDC00898
20	508.0	4700	123	19	—	HDC00899
24	609.6	1000	22	3	—	HDC00900
24	609.6	2000	43	7	—	HDC00901
24	609.6	4700	102	16	—	HDC00902
25¼	641.4	1500	31	5	—	HDC00903
30	762.0	2800	48	8	—	HDC00904
36	914.4	3000	43	7	—	HDC00905

3/4" Actual .746" (18.95 mm) Diameter Hi-Density Cartridge Heaters

Part Numbers listed are for stock Cartridge Heaters terminated with 10 inch long leads (Type N Termination). Other Terminator Program terminations and options can also be applied to stock heaters (see Ordering Information).

Sheath Length		Watts	Watt Density		Part Number	
in	mm		W/in ²	W/cm ²	120V	240V
2	50.8	200	57	9	HDC00906	—
2	50.8	800	226	35	—	HDC00907
2¼	57.2	200	49	8	HDC00908	—
2¼	57.2	800	194	30	—	HDC00909
3	76.2	250	42	7	HDC00910	—
3	76.2	500	85	13	HDC00911	HDC00912
3	76.2	600	102	16	HDC00913	HDC00914
3	76.2	1000	170	26	—	HDC00915
3½	88.9	250	35	6	HDC00916	HDC00917
3½	88.9	350	50	8	—	HDC00918
3½	88.9	500	71	11	HDC00919	—
3½	88.9	1000	141	22	—	HDC00920
3¾	95.3	250	33	5	HDC00921	—
3¾	95.3	500	65	10	—	HDC00922
3¾	95.3	1000	131	20	—	HDC00923
4	101.6	250	30	5	HDC00924	—
4	101.6	500	61	9	HDC00926	HDC00927
4	101.6	750	91	14	—	HDC00928
4	101.6	1000	121	19	HDC00929	HDC00930
4½	114.3	350	37	6	HDC00931	—
4½	114.3	875	93	14	HDC00932	HDC00933
4½	114.3	1400	149	23	—	HDC00934
4¾	120.7	750	75	12	—	HDC00935
5	127.0	300	28	4	HDC00936	HDC00937

Sheath Length		Watts	Watt Density		Part Number	
in	mm		W/in ²	W/cm ²	120V	240V
5	127.0	500	47	7	—	HDC00938
5	127.0	750	71	11	—	HDC00939
5	127.0	1000	94	15	HDC00940	HDC00941
5	127.0	1200	113	18	—	HDC00942
5¾	146.1	1000	81	13	—	HDC00943
6	152.4	500	39	6	HDC00944	HDC00945
6	152.4	750	58	9	—	HDC00946
6	152.4	1000	77	12	HDC00947	HDC00948
6	152.4	1200	93	14	—	HDC00949
6	152.4	1500	116	18	—	HDC00950
6	152.4	2000	154	24	—	HDC00951
7	177.8	500	33	5	HDC00952	HDC00953
7	177.8	1000	65	10	HDC00954	HDC00955
7	177.8	1500	98	15	HDC00956	HDC00957
7	177.8	2000	131	20	—	HDC00958
7¾	193.7	450	27	4	—	HDC00959
8	203.2	350	20	3	—	HDC00961
8	203.2	500	28	4	HDC00962	HDC00963
8	203.2	700	40	6	—	HDC00964
8	203.2	1000	57	9	—	HDC00965
8	203.2	1350	76	12	—	HDC00966
8	203.2	2000	113	18	HDC00967	HDC00968
9	228.6	350	17	3	—	HDC00969
9	228.6	500	25	4	—	HDC00970

Ordering Information

Order by Part Number for stock Cartridge heaters with Type N termination. Call Tempco for part numbers for stock heaters with other Terminator Program terminations and options (see pages 2-12 & 2-13).

Custom Engineered/Manufactured

Cartridge Heaters can be application specific; therefore for sizes, electrical ratings, terminations and any other design features not listed in this catalog **TEMPCO** will custom manufacture to your specifications. Consult us with your requirements.

STOCK — Immediate Delivery through the  Lead Conversion Program

3/4" Actual .746" (18.95 mm) Diameter Hi-Density Cartridge Heaters

Part Numbers listed are for stock Cartridge Heaters terminated with 10 inch long leads (Type N Termination). Other Terminator Program terminations and options can also be applied to stock heaters (see Ordering Information).

Sheath Length		Watts	Watt Density		Part Number	
in	mm		W/in ²	W/cm ²	120V	240V
9	228.6	1000	53	8	—	HDC22945
9	228.6	1200	60	9	—	HDC00971
9	228.6	1800	90	14	—	HDC00973
9¾	247.7	2000	92	14	—	HDC00974
10	254.0	600	27	4	—	HDC00975
10	254.0	1000	45	7	—	HDC00976
10	254.0	1200	54	8	—	HDC00977
10	254.0	1500	70	11	—	HDC22946
10	254.0	2000	89	14	HDC00978	HDC00979
10½	266.7	550	23	4	—	HDC00980
11	279.4	1000	40	6	—	HDC00981
11¾	298.5	2000	75	12	—	HDC00983
12	304.8	800	30	5	—	HDC00984
12	304.8	1000	37	6	—	HDC00985
12	304.8	1200	44	7	—	HDC00986
12	304.8	1500	55	9	—	HDC00987
12	304.8	2000	74	11	HDC00988	HDC00989
12	304.8	2500	92	14	—	HDC00990
12	304.8	4000	148	23	—	HDC00991
13	330.2	1000	34	5	—	HDC00992
14	355.6	800	25	4	—	HDC00993
14	355.6	1000	31	5	—	HDC00994
14	355.6	1125	35	6	HDC00995	—
14	355.6	1250	39	6	—	HDC00996
14	355.6	1400	44	7	—	HDC00997
14	355.6	2500	79	12	—	HDC00998
14	355.6	4500	141	22	—	HDC00999
14¾	374.7	1500	45	7	—	HDC01000

Sheath Length		Watts	Watt Density		Part Number	
in	mm		W/in ²	W/cm ²	120V	240V
15	381.0	1000	29	5	—	HDC01001
15	381.0	1500	44	7	—	HDC01002
16	406.4	1000	27	4	—	HDC01003
16	406.4	1175	32	5	HDC01004	—
16	406.4	1500	41	6	—	HDC01005
16	406.4	1800	49	8	—	HDC01006
16	406.4	3000	82	13	—	HDC01007
16	406.4	4700	129	20	—	HDC01008
17	431.8	1000	26	4	—	HDC01009
17¾	450.9	850	21	3	—	HDC01010
18	457.2	1000	24	4	—	HDC01011
18	457.2	1250	30	5	HDC01012	—
18	457.2	1450	35	6	—	HDC01013
18	457.2	2000	49	8	—	HDC01014
18	457.2	3250	79	12	—	HDC01015
18	457.2	5000	121	19	—	HDC01016
19	482.6	1000	23	4	—	HDC01017
20	508.0	1000	22	4	—	HDC01018
20	508.0	1150	25	4	—	HDC01019
20	508.0	2050	45	7	—	HDC01020
20	508.0	2250	49	8	—	HDC01021
20	508.0	5250	114	18	—	HDC01022
24	609.6	1000	18	3	—	HDC01023
24	609.6	1375	25	4	—	HDC01024
24	609.6	2000	36	6	—	HDC01025
24	609.6	2750	50	8	—	HDC01026
24	609.6	5500	99	15	—	HDC01027
36	914.4	2500	30	5	—	HDC01028

Ordering Information

Order by Part Number for stock Cartridge heaters with Type N termination. Call Tempco for part numbers for stock heaters with other Terminator Program terminations and options (see pages 2-12 & 2-13).

Custom Engineered/Manufactured

Cartridge Heaters can be application specific; therefore for sizes, electrical ratings, terminations and any other design features not listed in this catalog **TEMPCO** will custom manufacture to your specifications. Consult us with your requirements.

1" Dia. Actual .996" (25.30 mm) Hi-Density Cartridge Heaters with Type N termination 10" leads

Sheath Length		Watts	Watt Density		Part Number	
in	mm		W/in ²	W/cm ²	120V	240V
3	76.2	750	101	16	—	HDC02662
3½	88.9	565	63	10	—	HDC02663
5	127.0	1000	73	11	—	HDC02664
7¾	200.0	500	22	3	HDC02665	HDC02666
8	203.2	1500	65	10	—	HDC02667
8¾	222.3	875	34	5	—	HDC02668
11½	292.1	1000	29	5	HDC02669	—
13	330.2	1000	26	4	HDC02670	—
14	355.6	2700	64	10	—	HDC02671
15	381.0	1000	22	3	HDC02672	—

Sheath Length		Watts	Watt Density		Part Number	
in	mm		W/in ²	W/cm ²	120V	240V
16	406.4	1800	37	6	—	HDC02673
17¾	441.3	2400	46	7	—	HDC02674
20	508.0	1000	16	3	—	HDC02675
20	508.0	2800	46	7	—	HDC02676
25	635.0	1725	23	3	HDC02677	HDC02678
40	1016.0	4400	36	6	—	HDC02679
49	1244.6	3725	25	4	—	HDC02680
50½	1282.7	945	6	1	—	HDC02681
57	1447.8	2800	16	3	—	HDC02682
60	1524.0	1500	8	1	—	HDC02683



Note: 1" Dia. Hi-Density Cartridge Heaters are made-to-order only. Refer to ordering information on page 2-3. **Standard lead time is 3 weeks.**

Cartridge Heaters



Type F Terminated Stock Heaters

STOCK Cartridge Heaters with Type F Flexible Lead Termination

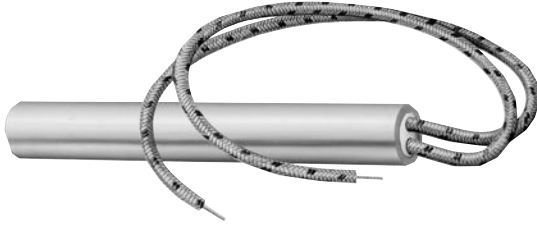

Type F Internally Connected Flexible Leads 10" Long

This lead termination provides flexibility; the lead wires are internally connected to the terminal pins. The lead wires can be sharply bent as they exit the ceramic insulating cap without exposing the bare wire.

1/4" Diameter Actual .246" (6.25 mm)

Sheath Length		Watts	Volts	Watt Density		Part Number
in	mm			W/in ²	W/cm ²	
1	25.4	80	120	204	32	HDC05603
1½	38.1	50	120	64	10	HDC06151
1½	38.1	200	120	255	40	HDC10869
2	50.8	200	240	170	26	HDC01989
2	50.8	250	240	212	33	HDC05179
2	50.8	300	240	255	40	HDC04556
2½	63.5	300	240	191	30	HDC07119
3	76.2	75	120	38	6	HDC10412
3	76.2	300	240	153	24	HDC04490
4	101.6	400	240	146	23	HDC04200
5¼	146.1	350	120	94	15	HDC04732

3/8" Diameter Actual .371" (9.42 mm)

Sheath Length		Watts	Volts	Watt Density		Part Number
in	mm			W/in ²	W/cm ²	
¼	31.8	150	240	170	26	HDC06254
¼	31.8	200	240	226	35	HDC04349
½	31.8	250	120	212	33	HDC04402
2	50.8	250	240	141	22	HDC04291
2	50.8	350	240	198	31	HDC11345
2½	63.5	250	240	106	16	HDC07496
2½	63.5	350	240	149	23	HDC04759
2½	63.5	500	240	212	33	HDC05359
3	76.2	300	240	102	16	HDC02094
3	76.2	375	240	127	20	HDC06779
3½	88.9	350	240	99	15	HDC04861
4	101.6	400	120	97	15	HDC04560
4	101.6	500	240	121	19	HDC04552
5½	139.7	1000	240	170	26	HDC05431
7	177.8	350	240	46	7	HDC05303
12	304.8	1000	240	74	11	HDC05833

1/2" Diameter Actual .496" (12.60 mm)

Sheath Length		Watts	Volts	Watt Density		Part Number
in	mm			W/in ²	W/cm ²	
2	50.8	300	240	127	20	HDC03872
3¼	79.4	500	240	121	19	HDC11162
3¼	79.4	250	240	48	7	HDC10330
4	101.6	500	240	91	14	HDC04676
4	101.6	600	240	109	17	HDC03878
5	127	500	240	71	11	HDC04701
6	152.4	500	240	58	9	HDC04677
6	152.4	750	240	87	14	HDC04352
6	152.4	1000	240	116	18	HDC03887
7	177.8	750	240	73	11	HDC03893
8	203.2	500	240	42	7	HDC02265
8	203.2	1000	240	85	13	HDC02263
10	254	1000	240	67	10	HDC04220

5/8" Diameter Actual .621" (15.77 mm)

Sheath Length		Watts	Volts	Watt Density		Part Number
in	mm			W/in ²	W/cm ²	
3	76.2	750	240	153	24	HDC04483
6	152.4	600	240	56	9	HDC11240
6	152.4	1000	240	93	14	HDC07353

All Items Available from Stock



Note: Custom Engineered/Manufactured Hi-Density Cartridge Heaters with Type F Flexible Lead Termination
Refer to ordering information on page 2-3.

Standard Size Stock Type CM 1/2" & 3/4" NPT Screw Plug Hi-Density Cartridge Immersion Heaters

Hi-Density Cartridge Immersion Heaters are designed for heating water and other liquids. The high watt density capability of this heater permits greater heat dissipation in a given area than would a tubular immersion heater.

However, it is important to note that allowable watt density depends on the material being heated. For water heating, watt densities of several hundred watts per square inch are possible; oil heating may be limited to 5 to 20 watts per square inch.

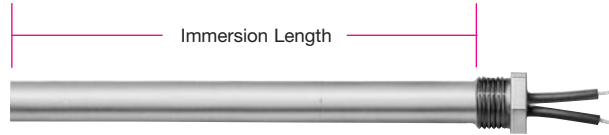

Design Features

- * Passivated Incoloy® Sheath
- * 10" long Teflon® Insulated Lead Wires
- * Brass Fitting
- * Epoxy Seal at Lead End
266°F (130°C) Standard
UL Rating 194°F (90°C)



Note: See pages 2-50 & 2-51 for other fitting options

Diameter	Heater Immersion Length		Watts	Watt Density		Part Number		
	in	mm		W/in ²	W/cm ²	120V	240V	480V
5/8" Incoloy® Sheath	1½	38.1	100	41	6	HDL00001	—	—
	1½	38.1	400	163	25	—	HDL00002	—
	3½	88.9	250	39	6	HDL00003	HDL00004	—
	3½	88.9	1000	157	24	—	HDL00005	HDL00006
1/2 NPT Fitting	7⅞	200.0	500	33	5	HDL00007	HDL00008	—
	7⅞	200.0	2000	134	21	—	HDL00009	HDL00010
	12	304.8	750	33	5	HDL00011	HDL00012	—
	12	304.8	3000	130	20	—	HDL00013	HDL00014
3/4" Incoloy® Sheath	4¼	108.0	500	53	8	HDL00015	HDL00016	—
	4¼	108.0	750	80	12	HDL00017	HDL00018	—
	4¼	108.0	1000	106	16	HDL00019	HDL00020	—
	4⅝	117.5	300	29	5	HDL00021	HDL00022	—
	4⅝	117.5	1200	116	18	—	HDL00023	HDL00024
	4⅝	120.7	375	35	5	HDL00025	HDL00026	—
	4⅝	120.7	1500	141	22	—	HDL00027	HDL00028
	5¼	146.1	500	39	6	HDL00029	HDL00030	—
	5¼	146.1	2000	154	24	—	HDL00031	HDL00032
	6¼	158.8	500	35	5	HDL00033	HDL00034	—
	6¼	158.8	2000	141	22	—	HDL00035	HDL00036
	6¼	165.1	625	42	7	HDL00037	HDL00038	—
3/4 NPT Fitting	6½	165.1	2500	170	26	—	HDL00039	HDL00040
	7¼	184.2	750	45	7	HDL00041	HDL00042	—
	7¼	184.2	3000	182	28	—	HDL00043	HDL00044
	9	228.6	1000	49	8	HDL00045	HDL00046	—
	9	228.6	4000	194	30	—	HDL00047	HDL00048
	10½	266.7	750	31	5	HDL00049	HDL00050	—
	10½	266.7	3000	124	19	—	HDL00051	HDL00052
	10¾	273.1	1250	51	8	HDL00053	HDL00054	—
	10¾	273.1	5000	202	31	—	HDL00055	HDL00056
	12½	317.5	1500	52	8	—	HDL00057	—
12½	317.5	6000	208	32	—	—	HDL00058	
13⅝	346.1	1000	32	5	HDL00059	HDL00060	—	
13⅝	346.1	4000	127	20	—	HDL00061	HDL00062	
16	406.4	2000	54	8	—	HDL00063	—	
16	406.4	8000	216	33	—	—	HDL00064	
19¼	489.0	2500	56	9	—	HDL00065	—	
19¼	489.0	10000	223	35	—	—	HDL00066	

Ordering Information

Stock Heaters

Part Numbers listed above are for 1/2" and 3/4" NPT Brass Screw Plug Cartridge Immersion Heaters with Type CM termination and 10" long leads. **Standard lead time is 72 hours.**

Custom Engineered/Manufactured Heaters

Because an electric heater can be very application specific, for sizes and ratings not listed, **TEMPCO** will design and manufacture a Cartridge Immersion Heater to meet your requirements. **Standard lead time is 3 weeks.**

Please Specify the following:

- Screw Plug NPT Size
- Screw Plug material (Brass or SS)
- Sheath material (Incoloy®, 321 SS)
- Element Watt Density
- Immersion Length
- Heated Length
- Wattage
- Voltage
- Termination types
- Lead Length

WARNING: Cancer and Reproductive Harm - www.P65Warnings.ca.gov.

(800) 323-6859 • Email: sales@tempco.com

Cartridge Heaters

Hi-Density Pennybottom™



Hi-Density Pennybottom™ Cartridge Heaters with Built-In Thermocouple

Designed for Trouble-Free Performance and Improved Efficiency

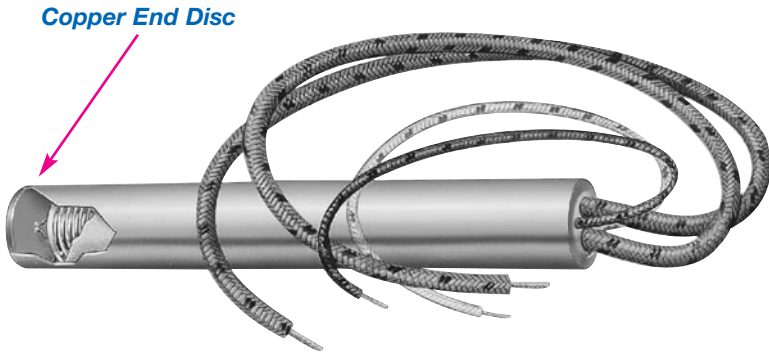

The unique feature of the Pennybottom™ cartridge heater is the use of a flat copper end disc to maximize heat transfer and improve temperature sensing. It has been proved through extensive field testing that heat at the tip can be increased by up to 30°F. The Pennybottom™ cartridge heater also includes a Type J thermocouple at the end disc. The junction is grounded to the flat copper end disc, providing excellent temperature control at the gating area, eliminating freeze-ups or drool, thus producing quality molded parts.

Additional features of Pennybottom™ heaters include minimum cold sections and computer designed distributed wattage. Pennybottom™ heaters are manufactured under the same design specifications and rigid quality control workmanship as the Hi-Density cartridge heater line. The swaging operation during the manufacturing process produces a rugged and durable cartridge heater for greater reliability and exceptionally long operating life.

Design Features

- * Pennybottom™ Copper Flat End Disc
- * Hi-Density Swaged Construction
- * Grounded Type J Thermocouple at the Copper End Disc
- * 36" High Temperature Leads for both Heater and Thermocouple
- * Minimum Cold Sections
- * OEM Replacements Available From Stock for Runnerless Molding Systems



Note: The cartridge heaters listed in this section include Pennybottom™ and Hi-Density cartridge heaters configured for specific tasks in the plastic injection molding environment with extra long leads, Teflon® or fiberglass insulation, with and without thermocouples, grounded at the end disc or in the middle of the heater.

PENNYBOTTOM™ HEATER SPECIFICATIONS

Nominal Diameter	1/4"		3/8"		1/2"	
	in	(mm)	in	(mm)	in	(mm)
Actual Diameter	.246	(6.30)	.371	(9.42)	.496	(12.60)
Diameter Tolerance	±.002	(.051)	±.002	(.051)	±.002	(.051)
Minimum Length	1	(25.40)	1	(25.40)	1-1/4	(31.75)
Maximum Length	36	(914)	48	(1219)	60	(1524)
Length Tolerance Heaters up to 5" (127 mm) long	± 3/32	(2.4)	± 3/32	(2.4)	± 3/32	(2.4)
Length Tolerance Heaters over 5" (127 mm) long	±2% of Sheath Length					
Camber Tolerance Heaters to 12" (305 mm) long	.010" (.254 mm) per Foot of Length					
Camber Tolerance Heaters over 12" (305 mm) long	.020" (.508 mm) per Foot of Length					



STOCK Hi-Density Pennybottom™ Cartridge Heaters with Built-In Type J Thermocouple

Cartridge Heater Diameter	Sheath Length		Watts	Watt Density		Part Number			
	in	mm		W/in ²	W/cm ²	120V Tempco	DME	240V Incoe	Tempco
1/4" Actual .248	1½	38.1	200	255	39	—	—	—	HDP00001
	1¾	44.5	200	204	32	HDP00002	—	—	—
	2	50.8	200	170	26	HDP00003	—	—	HDP00004
	2½	63.5	200	127	20	HDP00005	—	—	HDP00006
	3	76.2	200	102	16	HDP00007	—	—	HDP00008
	3½	88.9	250	106	16	—	—	—	HDP00009
	4	101.6	250	91	14	—	—	—	HDP00010
	5	127.0	250	71	11	—	—	—	HDP00011
3/8" Actual .371	1¾	44.5	200	136	21	—	TCH0001	TJ38017	HDP00012
	2	50.8	250	141	22	—	TCH0002	TJ38020	HDP00013
	2½	63.5	250	106	16	—	TCH0003	TJ38025	HDP00014
	3	76.2	260	88	14	—	TCH0004	TJ38030	HDP00015
	3½	88.9	320	91	14	—	TCH0005	TJ38035	HDP00016
	4	101.6	370	90	14	—	TCH0006	TJ38040	HDP00017
	4½	114.3	420	89	14	—	TCH0007	TJ38045	HDP00018
	5	127.0	470	89	14	—	TCH0008	TJ38050	HDP00019
	5½	139.7	525	89	14	—	TCH0009	TJ38055	HDP00020
	6	152.4	575	89	14	—	TCH0010	TJ38060	HDP00021
	6½	165.1	625	88	14	—	TCH0011	TJ38065	HDP00022
	7	177.8	675	88	14	—	TCH0012	TJ38070	HDP00023
	7½	190.5	725	88	14	—	TCH0013	TJ38075	HDP00024
	8	203.2	775	88	14	—	TCH0014	TJ38080	HDP00025
	9	228.6	885	88	14	—	—	TJ38090	HDP00026
9½	241.3	940	89	14	—	—	TJ38095	HDP00027	
1/2" Actual .496	10	254.0	990	88	14	—	—	TJ38100	HDP00028
	10½	266.7	1045	89	14	—	—	TJ38105	HDP00029
	11½	292.1	1500	116	18	—	—	TJ38115	HDP00030
	2½	63.5	280	89	14	—	—	TJ12025	HDP00031
	3½	88.9	420	89	14	—	TCH0015	TJ12035	HDP00032
	4	101.6	490	89	14	—	TCH0016	TJ12040	HDP00033
	4½	114.3	550	88	14	—	TCH0017	TJ12045	HDP00034
	5	127.0	625	88	14	—	TCH0018	TJ12050	HDP00035
	5½	139.7	700	89	14	—	TCH0019	TJ12055	HDP00036
	6	152.4	775	90	14	—	TCH0020	TJ12060	HDP00037
	6½	165.1	850	90	14	—	TCH0021	TJ12065	HDP00038
	7	177.8	900	88	14	—	—	TJ12070	HDP00039
	7½	190.5	975	89	14	—	TCH0022	TJ12075	HDP00040
	8	203.2	1050	89	14	—	—	TJ12080	HDP00041
	8½	215.9	1100	88	14	—	—	TJ12085	HDP00042
9	228.6	1200	90	14	—	—	TJ12090	HDP00043	
9½	241.3	1250	88	14	—	—	TJ12095	HDP00044	
10	254.0	1325	89	14	—	—	TJ12100	HDP00045	
10½	266.7	1400	89	14	—	—	TJ12105	HDP00046	
11	279.4	1470	89	14	—	—	TJ12110	HDP00047	
12½	317.5	1675	89	14	—	—	TJ12125	HDP00048	
13½	342.9	1800	88	14	—	—	TJ12135	HDP00049	

All Items Available from Stock

Ordering Information

Stock Heaters

Order by Catalog Part Number from the Stock Sizes and Ratings List above. Note that Part Numbers shown are for heaters with 36" Heater and T/C Leads. Thermocouple Type J grounded at disc end.

Custom Engineered/Manufactured Heaters

Because an electric heater can be very application specific, for sizes and ratings not listed, **TEMPCO** will design and manufacture a Pennybottom™ Cartridge Heater to meet your requirements. **Standard lead time is 3 weeks.**

Please Specify the following:

- Diameter
- Length
- Wattage
- Voltage
- Lead and Thermocouple Lengths
- Special Features

⚠ WARNING: Cancer and Reproductive Harm - www.P65Warnings.ca.gov.

(800) 323-6859 • Email: sales@tempco.com

Cartridge Heaters



OEM Replacement

STOCK OEM Replacement Cartridge Heaters for Runnerless Molding Hot Tip Bushings

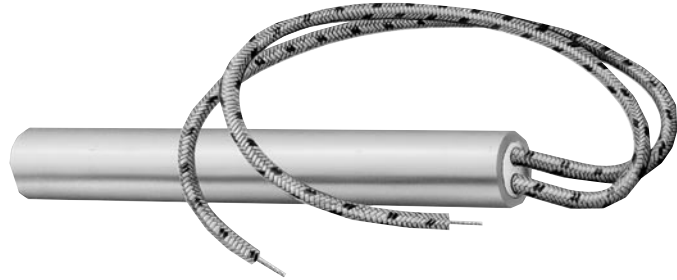

Non-Thermocouple Type F Heaters — 240V

Design Features

- * Pennybottom™ Copper Flat End Disc
- * Hi-Density Swaged Construction
- * 36" High Temperature Heater Flexible Leads
- * Computer Designed Distributed Wattage
- * Designed for 240VAC

Non-Thermocouple Type F Heaters — 240V

Cartridge Heater Diameter	Sheath Length in	Watts	Part Number	
			Incoe	TEMPCO
3/8" Actual .371	1 3/4	200	H-38017	HDP00050
	2 1/2	250	H-38025	HDP00051
	3	260	H-38030	HDP00052
	4	370	H-38040	HDP00053
	4 1/2	420	H-38045	HDP00054
	5	470	H-38050	HDP00055
	5 1/2	525	H-38055	HDP00056
	6	575	H-38060	HDP00057
	6 1/2	625	H-38065	HDP00058
	7	675	H-38070	HDP00059
	7 1/2	725	H-38075	HDP00060
	8	775	H-38080	HDP00061
	8 1/2	835	H-38085	HDP00062
	9	885	H-38090	HDP00063
	9 1/2	940	H-38095	HDP00064
	10	990	H-38100	HDP00065
	10 1/2	1045	H-38105	HDP00066
	11 1/2	1150	H-38115	HDP00067
13	1300	H-38130	HDP00068	
13 1/2	1350	H-38135	HDP00069	
1/2" Actual .496	3 1/2	420	H-12035	HDP00070
	4	490	H-12040	HDP00071
	4 1/2	550	H-12045	HDP00072
	5	625	H-12050	HDP00073
	5 1/2	700	H-12055	HDP00074
	6	775	H-12060	HDP00075
	6 1/2	850	H-12065	HDP00076
	7	900	H-12070	HDP00077
	7 1/2	975	H-12075	HDP00078
	8	1050	H-12080	HDP00079
	8 1/2	1100	H-12085	HDP00080
	9	1200	H-12090	HDP00081
	9 1/2	1250	H-12095	HDP00082
	10	1325	H-12100	HDP00083
	10 1/2	1400	H-12105	HDP00084
	11	1470	H-12110	HDP00085
	11 1/2	1525	H-12115	HDP00086
	12 1/2	1675	H-12125	HDP00087
13 1/2	1800	H-12135	HDP00088	
14 1/2	1950	H-12145	HDP00089	
15 1/2	2100	H-12155	HDP00090	
16 1/2	2200	H-12165	HDP00091	
17 1/2	2300	H-12175	HDP00092	
18 1/2	2500	H-12185	HDP00093	
19 1/2	2875	H-12195	HDP00094	

All Items Available from Stock

STOCK OEM Replacement Hi-Density Cartridge Heaters — Underwater Pelletizer Die Heater

Design Features

- * Hi-Density Swaged Construction
- * 44" mica insulated 842°F (450°C) Lead Wires
- * 1" Diameter Heater Sheath
- * Incoloy Sheath Standard, SS Optional
- * 16 Gauge Stainless Steel Mounting Flange
- * Ground Lead Optional
- * Other Options Available (wattage, voltage, lead length etc.)

Type R2A Cement potting and silicone varnish

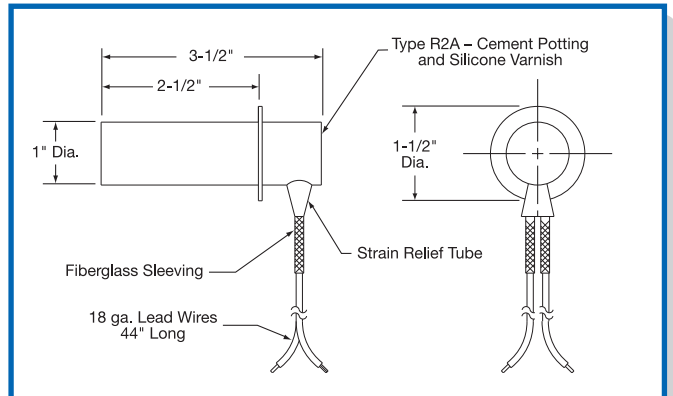
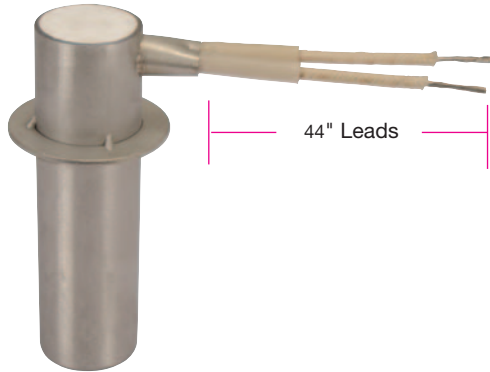

Type R2A 600W, 240V — Part Number HDC02661

Type W1A Cement potting and silicone varnish

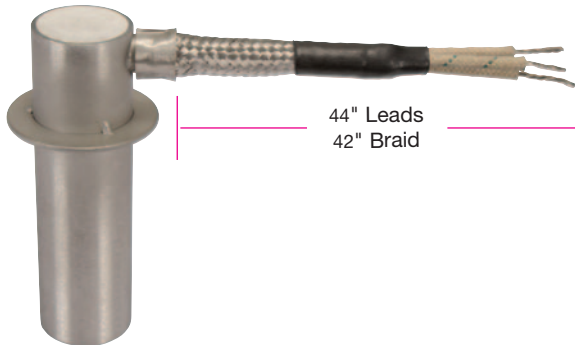

Type C3B Cement potting & silicone varnish, with stainless steel cable

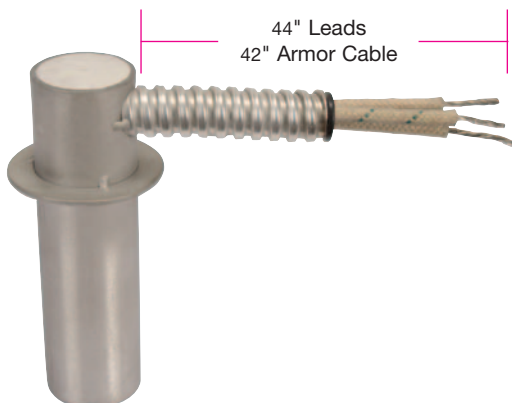

Type C3D Welded lead end disc, with stainless steel cable

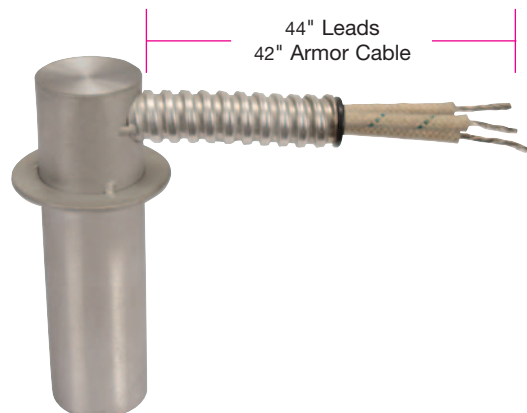

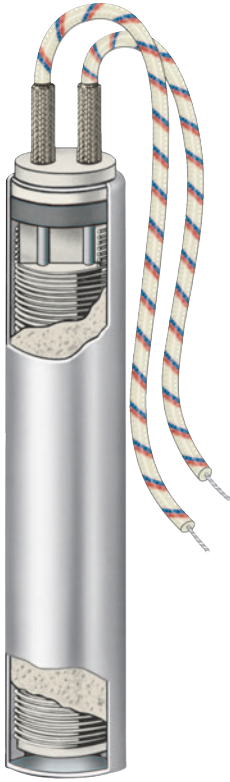

METRIC SIZES

Hi-Density

CARTRIDGE HEATERS

Standard Specifications and Tolerances of Hi-Density Cartridge Heaters in **Metric** sizes. If tighter tolerances are required consult Tempco.

LEAD LENGTH TOLERANCE

Up to 1000 mm: -15/+40 mm
 1000 mm to 2000 mm: -25/+50 mm
 Above 2000 mm: ±100 mm

DIMENSIONAL SPECIFICATIONS

Nominal Diameter	6.5		8		10		12.5		16		20	
	mm	(in)	mm	(in)	mm	(in)	mm	(in)	mm	(in)	mm	(in)
Actual Diameter	6.43	(.253)	7.92	(.312)	9.93	(.391)	12.42	(.489)	15.93	(.627)	19.91	(.784)
Actual Diameter Tolerance	±.05 mm (±.002")											
Minimum Length	25.4	(1)	25.4	(1)	25.4	(1)	25.4	(1)	25.4	(1)	31.75	(1-1/4)
Maximum Length	914	(36)	914	(36)	1219	(48)	1524	(60)	1829	(72)	1829	(72)
Length Tolerance												
Heaters up to 127 mm (5") long	±2.4	(3/32)	±2.4	(3/32)	±2.4	(3/32)	±2.4	(3/32)	±2.4	(3/32)	±3.2	(1/8)
Length Tolerance Heaters over 127 mm (5") long	±2% of Sheath Length											
Camber Tolerance Heaters to 305 mm (12") long	.25 mm (.010") per 305 mm (12") of length											
Camber Tolerance Heaters over 305 mm (12") long	.50 mm (.020") per 305 mm (12") of length											

With some force, Tempco Hi-Density Cartridge Heaters will normally flex enough to fit into a straight reamed hole.

ELECTRICAL SPECIFICATIONS

Nominal Diameter	6.5	8	10	12.5	16	20
Maximum Voltage	260	260	260	380	480*	480*
Maximum Amperage (see next line for exceptions)	4.4	4.4	6.7	10.5	23	23
†Maximum Amperage for Types C1C, C1D, C2C, C2D, CS, F, M3, R1B, S1B, S2B, SA, W, & W3 & Terminations	3.0	3.0	5.5	7.6	9.7	9.7
Maximum Wattage at 260V	1140	1150	1740	2730	5980	5980
Maximum Wattage at 380V	—	—	—	3990	8740	8740
Maximum Wattage at 480V	—	—	—	—	10,580	10,580
Wattage Tolerance	Plus 5%, Minus 10%					
Resistance Tolerance	Plus 10%, Minus 5%					

*480V when applicable. Consult Tempco.

†Current carrying capacities are for ambient temperatures up to 482°F (250°C) with mica insulated lead wires.

Recommendations for Improving the Life of Tempco Hi-Density Metric Cartridge Heaters

Tempco Hi-Density Metric Cartridge Heaters have been widely used in many demanding and diverse applications since 1972. The commonly used basic applications are platen, plastic mold and die heating, liquid immersion and air heating.



Note: Selection of the wrong termination for the particular application is the major reason for all heater failures. However, failure to consider other important criteria can also have a negative effect on the life of the heater. To get the best performance and assure long life, it is important to carefully evaluate the following factors.

Operating Temperature

Operating temperature of a heater is a major factor in determining the life expectancy of a heating element. The heater life depends on the actual temperature of the resistance wire within the heater and not on the process operating temperature. The graph in Fig. 1 demonstrates the proper relationship between operating temperature and watt density; the higher the operating temperature, the lower the maximum recommended watt density.

Heater Watt Density

Cartridge heater watt density is defined as the wattage dissipated per square centimeter of the heated sheath surface. For a particular application a heater's watt density governs internal resistance wire temperature, which determines the outer sheath temperature. These factors are critical to the proper heating of the application and to the life expectancy of the heater. Special construction features that promote excellent heat transfer permit Hi-Density cartridge heaters to operate at higher watt densities while maintaining the lowest possible resistance wire temperatures of any style cartridge heater.

Heater watt density (w/cm^2) is calculated using the following formula:

$$\text{Watt Density} = \frac{\text{Heater wattage}}{\text{Heated length} \times \text{Heater diameter} \times 3.1416}$$

Heated length is the overall length of the heater minus any unheated (cold) sections. Standard Type N, Hi-Density Metric Cartridge Heaters have 9.5 mm at the lead end and 6.4 mm at the disc end unheated. This would mean a 100 mm long heater would have 84.1 mm effective heated length. Unheated sections vary with type of heater termination. For descriptions of terminations and options, see pages 2-39 through 2-60.

The graph in Fig. 1 shows the maximum recommended watt density for Hi-Density Metric Cartridge Heaters when used in a steel platen. Watt density limitations for various materials are given in the engineering section of this catalog. For liquid immersion heaters the maximum watt density depends on the type of liquid being heated. The more viscous, or thicker the liquid, the lower the maximum watt density. Higher watt density can cause the liquid to carbonize and accumulate on the heater sheath, which will cause premature heater failure. It is advisable to use heaters that have watt densities below the maximum recommended watt density to get the longest heater life. If the actual heater watt density is close to the maximum recommended watt density, you can correct the problem by:

1. Increasing the number, diameter and length of heaters.
2. Lowering the total wattage; however, this may increase the heat-up time.
3. Obtaining tighter fit (see Fig. 2 — Determining Fit).

A Hi-Density cartridge heater designed at the maximum recommended watt density allows the smallest heater to be used to obtain the required wattage with good service life. All things being equal, using a lower watt density heater will typically provide optimized service life.

FIG. 1
Recommended Watt Density for Heating Metal Parts

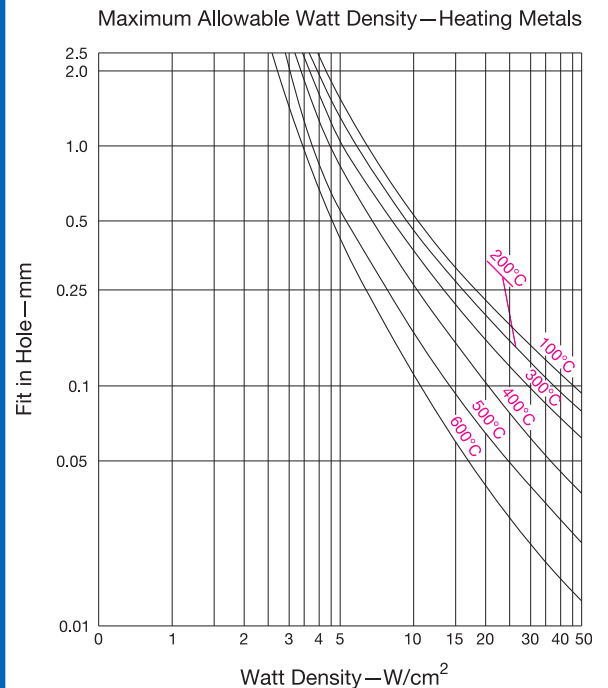

The graph shows the recommended maximum watt density for Tempco Hi-Density Metric Cartridge Heaters at different operating temperatures and fit, when the heater is installed in an oxidized mild steel block. The thermocouple is located 12.5 mm from the heater. When heating other materials, the data needs to be extrapolated based on the thermal conductivity of the material. Consult Tempco with your requirements.

FIG. 2
Determining Fit

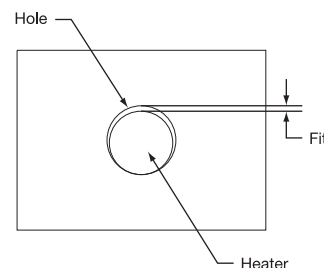

CONTINUED 

Recommendations for Improving the Life of Tempco Hi-Density Metric Cartridge Heaters

Continued from previous page...

Determining Fit

When heating a platen, mold, die or hot runner probe with Hi-Density Metric Cartridge Heaters inserted into drilled holes, fit is an important factor in determining the life expectancy of the heater. Fit is the difference between the minimum diameter of the cartridge heater and the maximum diameter of the hole. Unheated sections on a Hi-Density cartridge may be smaller in diameter due to swaging. To determine fit, use the smallest diameter on the heated length only.

Example: A 10 mm nominal OD Hi-Density cartridge heater has an actual diameter of 9.95 ± 0.03 mm, which translates to a minimum diameter of 9.92 mm. If used in a $10.01 \text{ mm} \pm 0.02$ mm hole, the fit would be .11 mm ($10.03 \text{ mm} - 9.92 \text{ mm} = 0.11 \text{ mm}$).

When medium watt density heaters (less than 9.30 watts per square centimeter) are used in low temperature applications (less than 600°F [315°C]) general purpose drills are commonly used to drill holes. The typical hole size may be 0.07 mm to 0.20 mm over the drill size. For higher watt density and/or higher temperature applications, we recommend that the holes are drilled and reamed for the tightest possible fit. In applications where precise temperature control and heat transfer properties are required, Hi-Density cartridge heaters can be centerless ground to ± 0.01 mm.

Although a tighter fit is desirable to efficiently transfer heat and to get long heater life, a looser fit will aid in installing and removing heaters, especially long heaters. We recommend that you apply Tempco's BNS anti-seize cartridge heater coating as it will improve heat transfer and will make the removal of heaters easier.

The graph in Fig 1. (page 2-29) shows the effect of fit in determining the maximum recommended watt density on a steel platen. As it is indicated in the graph, the tighter the fit, the higher the maximum recommended watt density.

Temperature Control and Location of Temperature Sensing Device

In order to better control the heater temperature and hence the resistance wire temperature, use of an appropriate temperature control and the proximity of the heater to the sensor is very important. The graph in Fig 1. (page 2-29) shows the effect of operating temperature in determining the maximum recommended watt density on a steel platen where the sensor is located 12.5 mm from the heater. Higher watt density heaters can generate heat faster than the surrounding area's ability to dissipate heat. This creates a thermal lag between the heater and the sensor. The closer the sensor to the heater, the better you can control the heater temperature. By keeping the sensor further from the heater, temperature gradients of several hundred degrees can be observed in many applications, especially during initial start-up and heavy thermal cycling. Although the set operating temperature may be low, the heater may be running at a very high temperature. This is a common cause of heater failure. This can be minimized using time proportional and PID functions of the temperature controllers. See Section 13 for temperature controllers and Section 14 for thermocouples and sensors.

Power Control

Power control methods affect the life expectancy of heating elements. In general, although economical, on-off controls increase thermal fatigue and oxidation rate on heating elements by causing wide temperature swings of the internal heating element. Silicon Controlled Rectifiers (SCRs), Mercury Relays and Solid State Power Controls can increase the life expectancy of heating elements by reducing the temperature swings of the internal heating element. See Section 13 for power controls.

Important Installation Considerations

1. For closest fit and best heat transfer, use reamed holes.
2. When possible, drill holes through the object being heated. This will make heater removal easier.
3. When using an anti-seize coating like Tempco's BNS spray or paste, **do not apply** over lead wires or any other current carrying conductors.
4. When using insulated tape or sleeving, check to make sure it is rated for the temperature of the application. Lower temperature rated materials can contain an adhesive or binder that can carbonize and become electrically conductive.
5. When using heaters near their maximum recommended watt density, it is recommended that the temperature sensing probes be located approximately 12.5 mm from the heater sheath.
6. Lead wires should not be located in the hole containing the cartridge heater during operation. This may cause the lead wires to be exposed to temperatures above their rated temperature.
7. When used in a vacuum application, make sure the lead end of the heater is outside the vacuum. If the lead has to be in the vacuum, consult Tempco for specific recommendations.
8. Many applications will subject a heater's electrical terminations to one or more of the following potentially damaging conditions:
 - Moisture
 - Flexing
 - Oil and other contaminants
 - Abrasion
 - High temperature

Note: To protect the heater from damage in these harsh environments, Tempco has a wide selection of terminations and options available. See pages 2-39 through 2-60 for details.

CALCULATING WATTAGE REQUIREMENTS

Formulas and related data to calculate wattage requirements are detailed in the Engineering Section located at the back of this catalog. For new applications it is recommended that testing under actual operating conditions be performed to confirm wattage and watt density calculations.

An excellent evaluation method is to power up a heater with the calculated wattage and watt density through a variable voltage transformer. By changing the voltage and therefore the heater output, thermocouples sensing heater and process temperature can verify the design.

Standard (Non-Stock) Hi-Density Metric Cartridge Heaters

6.5 mm Diameter Actual 6.45 mm (.253")

Sheath Length (mm)	Watts	Watt Density (W/cm ²)	Part Number 220V
40	50	9	HDM00001
40	75	13	HDM00002
40	100	18	HDM00003
40	125	22	HDM00004
40	150	27	HDM00005
60	50	5	HDM00006
60	100	10	HDM00007
60	150	15	HDM00008
60	200	21	HDM00009
60	250	26	HDM00010

Sheath Length (mm)	Watts	Watt Density (W/cm ²)	Part Number 220V
80	100	7	HDM00011
80	150	11	HDM00012
80	200	15	HDM00013
80	300	22	HDM00014
80	400	29	HDM00015
100	100	6	HDM00016
100	200	11	HDM00017
100	300	17	HDM00018
100	400	22	HDM00019
100	500	28	HDM00020
130	100	4	HDM00021
130	250	10	HDM00022
130	400	17	HDM00023
130	500	21	HDM00024
130	600	25	HDM00025

8 mm Diameter Actual 7.95 mm (.312")

Sheath Length (mm)	Watts	Watt Density (W/cm ²)	Part Number 220V
40	50	7	HDM00026
40	75	11	HDM00027
40	100	14	HDM00028
40	150	22	HDM00029
40	200	29	HDM00030
60	75	6	HDM00031
60	150	13	HDM00032
60	200	17	HDM00033
60	250	21	HDM00034
60	300	25	HDM00035
80	100	6	HDM00036
80	200	12	HDM00037
80	300	18	HDM00038
80	400	24	HDM00039
80	500	29	HDM00040
100	100	5	HDM00041
100	250	11	HDM00042
100	400	18	HDM00043
100	500	23	HDM00044
100	600	27	HDM00045

Sheath Length (mm)	Watts	Watt Density (W/cm ²)	Part Number 220V
130	200	7	HDM00046
130	350	12	HDM00047
130	500	17	HDM00048
130	600	20	HDM00049
130	700	24	HDM00050
160	200	5	HDM00051
160	400	11	HDM00052
160	600	16	HDM00053
160	700	19	HDM00054
160	900	24	HDM00055
200	300	6	HDM00056
200	500	11	HDM00057
200	700	15	HDM00058
200	900	19	HDM00059



Note: Part Numbers above are for Hi-Density Cartridge Heaters terminated with Type N leads, 250 mm (10") long. See pages 2-39 through 2-57 for other terminations.

Metric Size Cartridge Heaters are made-to-order only. **Standard lead time is 3 weeks.**

Custom Engineered/Manufactured Hi-Density Metric Cartridge Heaters

Refer to ordering information on page 2-33.

Standard (Non-Stock) Hi-Density Metric Cartridge Heaters

10 mm Diameter Actual 9.95 mm (.391")

Sheath Length (mm)	Watts	Watt Density (W/cm ²)	Part Number 220V
40	50	6	HDM00060
40	100	12	HDM00061
40	150	17	HDM00062
40	200	23	HDM00063
40	250	29	HDM00064
60	100	7	HDM00065
60	150	10	HDM00066
60	200	13	HDM00067
60	300	20	HDM00068
60	400	27	HDM00069
80	100	5	HDM00070
80	200	9	HDM00071
80	300	14	HDM00072
80	400	19	HDM00073
80	600	28	HDM00074
100	200	7	HDM00075
100	300	11	HDM00076
100	400	15	HDM00077
100	500	18	HDM00078
100	700	25	HDM00079
130	200	5	HDM00080
130	400	11	HDM00081
130	600	16	HDM00082

Sheath Length (mm)	Watts	Watt Density (W/cm ²)	Part Number 220V
130	800	22	HDM00083
130	1000	27	HDM00084
160	200	4	HDM00085
160	500	11	HDM00086
160	800	17	HDM00087
160	1000	22	HDM00088
160	1200	26	HDM00089
200	300	5	HDM00090
200	600	10	HDM00091
200	1000	17	HDM00092
200	1200	20	HDM00093
200	1400	24	HDM00094
250	400	5	HDM00095
250	700	9	HDM00096
250	1000	13	HDM00097
250	1400	20	HDM00098
300	500	6	HDM00099
300	1000	11	HDM00100
300	1500	17	HDM00101

12.5 mm Diameter Actual 12.45 mm (.489")

Sheath Length (mm)	Watts	Watt Density (W/cm ²)	Part Number 220V
60	100	6	HDM00102
60	200	12	HDM00103
60	300	17	HDM00104
60	400	23	HDM00105
60	500	29	HDM00106
80	150	6	HDM00107
80	300	12	HDM00108
80	400	16	HDM00109
80	500	20	HDM00110
80	700	28	HDM00111
100	200	6	HDM00112
100	400	12	HDM00113
100	600	18	HDM00114
100	800	24	HDM00115
100	1000	30	HDM00116
130	250	6	HDM00117

Sheath Length (mm)	Watts	Watt Density (W/cm ²)	Part Number 220V
130	500	11	HDM00118
130	800	18	HDM00119
130	1000	22	HDM00120
130	1400	31	HDM00121
160	300	5	HDM00122
160	600	11	HDM00123
160	1000	18	HDM00124
160	1400	25	HDM00125
160	1700	30	HDM00126
200	400	6	HDM00127
200	700	10	HDM00128
200	1000	14	HDM00129
200	1500	21	HDM00130
200	2000	28	HDM00131
250	500	5	HDM00132
250	1000	11	HDM00133
250	1500	16	HDM00134
250	2000	22	HDM00135
300	600	5	HDM00136
300	1500	13	HDM00137
300	2000	18	HDM00138



Note: Part Numbers above are for Hi-Density Cartridge Heaters terminated with Type N leads, 250 mm (10") long. See pages 2-39 through 2-57 for other terminations.

Metric Size Cartridge Heaters are made-to-order only. **Standard lead time is 3 weeks.**

Custom Engineered/Manufactured Hi-Density Metric Cartridge Heaters

Refer to ordering information on page 2-33.

Standard (Non-Stock) Hi-Density Metric Cartridge Heaters

16 mm Diameter Actual 15.95 mm (.627")

Sheath Length (mm)	Watts	Watt Density (W/cm ²)	Part Number 220V
60	100	5	HDM00139
60	300	14	HDM00140
60	400	18	HDM00141
60	500	23	HDM00142
60	700	32	HDM00143
80	200	6	HDM00144
80	400	12	HDM00145
80	600	19	HDM00146
80	800	25	HDM00147
80	1000	31	HDM00148
100	300	7	HDM00149
100	500	12	HDM00150
100	700	17	HDM00151
100	1000	24	HDM00152
100	1300	31	HDM00153
130	400	7	HDM00154

Sheath Length (mm)	Watts	Watt Density (W/cm ²)	Part Number 220V
130	600	10	HDM00155
130	800	14	HDM00156
130	1200	21	HDM00157
130	1600	28	HDM00158
160	500	7	HDM00159
160	700	10	HDM00160
160	1000	14	HDM00161
160	1500	21	HDM00162
160	2000	28	HDM00163
200	600	6	HDM00164
200	1000	11	HDM00165
200	1500	16	HDM00166
200	2000	22	HDM00167
250	700	6	HDM00168
250	1500	13	HDM00169
250	2000	17	HDM00170
300	1000	7	HDM00171
300	1500	11	HDM00172
300	2000	14	HDM00173

20 mm Diameter Actual 19.95 mm (.784")

Sheath Length (mm)	Watts	Watt Density (W/cm ²)	Part Number 220V
60	250	8	HDM00174
60	400	13	HDM00175
60	300	10	HDM00176
60	500	17	HDM00177
80	500	12	HDM00178
80	800	19	HDM00179
100	650	12	HDM00180
100	1000	18	HDM00181
130	300	4	HDM00182
130	800	11	HDM00183
130	1250	17	HDM00184
160	800	9	HDM00185

Sheath Length (mm)	Watts	Watt Density (W/cm ²)	Part Number 220V
160	1000	11	HDM00186
160	1250	13	HDM00187
200	1000	8	HDM00188
200	1200	10	HDM00189
200	1600	14	HDM00190
250	1250	8	HDM00191
250	1750	12	HDM00192
250	2000	13	HDM00193
300	1600	9	HDM00194
300	2200	12	HDM00195



Note: Part Numbers above are for Hi-Density Cartridge Heaters terminated with Type N leads, 250 mm (10") long. See pages 2-39 through 2-57 for other terminations.

Ordering Information

Catalog Heaters

Order by Catalog Part Number from the Standard Sizes and Ratings List on the preceding pages. Note that Part Numbers shown are for heaters with Type N Termination (250 mm leads). Available Terminations and Optional Features can be found on pages 2-39 through 2-60.

Custom Engineered/Manufactured Heaters

Because an electric heater can be very application specific, for sizes and ratings not listed, **TEMPCO** will design and manufacture a Hi-Density Metric Cartridge Heater to meet your requirements. **Standard lead time is 3 weeks.**

Please Specify the following:

- Diameter
- Length
- Wattage
- Voltage
- Termination types (see pages 2-39 through 2-51)
- Options/Special Features (see pages 2-52 through 2-60)
- Lead Length
- Cable/Braid length
- Application Type
- Operating Temperature



Low-Density

CARTRIDGE HEATER FEATURES

*An Economical and Reliable Cartridge Heater,
Used in Applications Requiring
Lower Operating Temperatures and Watt Densities*

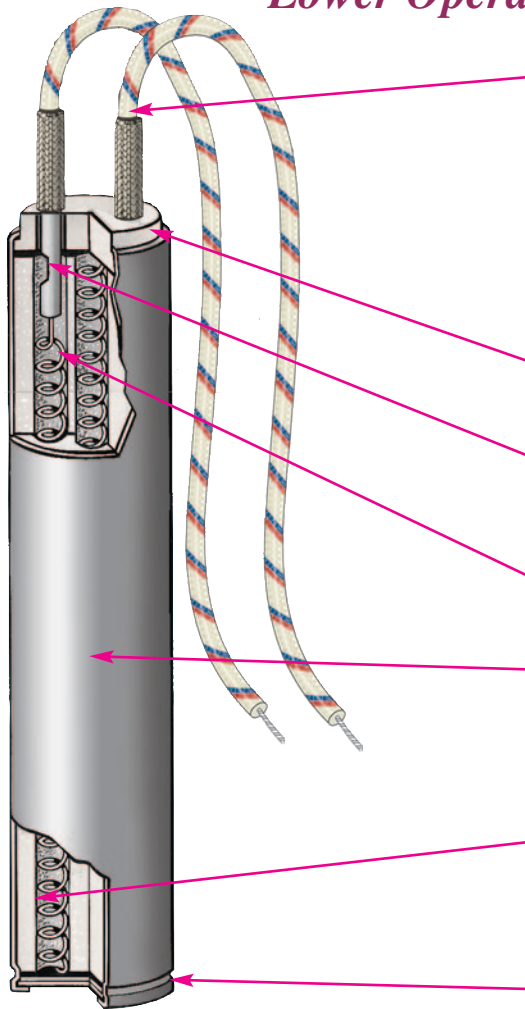

A The standard termination for Low-Density Cartridge Heaters is Type F, consisting of 10" (254 mm) internally connected flexible lead wires with high temperature insulation, UL approved for 300 Volt or 600 Volt service and temperature rated to 482°F (250°C).



Note: To meet the requirements of your application we offer over 40 standard termination styles to select from that will solve many of the most common application problems. See pages 2-39 through 2-60.

B Ceramic end cap protects the cartridge internally from outside contamination.

C Resistance wire and lead wires are mechanically spliced with heavy wall nickel connectors for a positive electrical connection.

D Helically wound Nickel-Chrome resistance wire is evenly stretched and strung through ceramic insulators.

E Alloy 304 Stainless Steel is used to provide high temperature strength, good thermal conductivity and resistance to oxidation up to 1200°F (650°C). Alloy 304 is a Nickel-Chromium Stainless Steel. For immersion heating of corrosive solutions consult Tempco.

F Specially selected grain size high purity Magnesium Oxide (MgO) is used to fill all remaining space inside the ceramic insulator, thus increasing thermal conductivity, dielectric strength and heater life.

G Sheath is roll crimped over a 304 Stainless Steel end disc. A mica spacer electrically insulates the heater core from the end disc. This style end seal is not moisture proof.



Low Density Cartridge Heaters are UL recognized and CSA certified in many design variations under UL File Number E65652 and CSA File Number 043099.

If you require UL and/or CSA Agency Approval, please specify when ordering.

Tempco Low-Density Cartridge Heaters are an excellent, cost effective choice without compromising quality for Original Equipment Manufacturers (OEMs) consuming large quantities of cartridge heaters for their equipment.

Typical Applications

- Heat Sealing Equipment
- Laminating Equipment
- Packaging Equipment
- Labeling Machines

- Molds and Dies
- Food Processing
- Refrigeration
- Shoe Machinery

- Glue Guns
- Wax Pots
- Heating Liquids
- Heating Gases



Low-Density Cartridge Heater Specifications

Standard Specifications and Tolerances of Low Density Cartridge Heaters. If tighter tolerances are required consult Tempco.

PERFORMANCE RATINGS

Maximum Temperature: 1200°F (650°C)

Maximum Watt Density: 20-45 W/in² (3.1-7.0 W/cm²) depending on heater size and operating temperature.

DIMENSIONAL SPECIFICATIONS

Nominal Diameter	3/16	1/4	3/8	1/2	5/8	3/4	7/8	1	1-1/4
Actual Diameter— in.	.185	.247	.372	.496	.621	.745	.870	.995	1.250
Actual Diameter—(mm)	(4.70)	(6.27)	(9.45)	(12.60)	(15.77)	(18.92)	(22.10)	(25.27)	(31.75)
Diameter Tolerance	±.002 (.051 mm)				±.003 (.076 mm)				±.005 (.127 mm)
Length Tolerance	±1/16 (1.59 mm) up to 6" (152.4 mm) long; ±1/8" (3.18 mm) over 6" long								
Camber Tolerance	.010" (.254 mm) per foot of length								

ELECTRICAL SPECIFICATIONS

Nominal Diameter	3/16	1/4	3/8	1/2	5/8	3/4	7/8	1	1-1/4
Maximum Voltage	240	240	240	240	480*	480*	480*	480*	480*
Maximum Amperage	1.5	3.5	6	8	10	15	15	25	30
Maximum Wattage	Consult Tempco								
Wattage Tolerance	Plus 5%, Minus 10%								
Resistance Tolerance	Plus 10%, Minus 5%								

*480V when applicable. Consult Tempco.

Standard (Non-Stock) Low-Density Cartridge Heaters

3/16" Diameter Actual .185" (4.70 mm)

Sheath Length	Watts		Watt Density		Part Number	
	in	mm	W/in ²	W/cm ²	120V	240V
1	25.4	15	34	5.3	LDC00001	—
1½	38.1	20	30	4.7	LDC00002	—
2	50.8	30	31	4.9	LDC00003	—
2½	63.5	40	32	5.0	LDC00004	—
3	76.2	45	29	4.5	LDC00005	—
4	101.6	65	31	4.7	LDC00006	—
5	127.0	80	29	4.6	LDC00007	—
6	152.4	100	30	4.7	LDC00008	—
7	177.8	125	32	5.0	LDC00009	—
8	203.2	150	33	5.2	LDC00010	—
10	254.0	170	30	4.7	LDC00011	—

1/4" Diameter Actual .247" (6.27 mm)

Sheath Length	Watts		Watt Density		Part Number	
	in	mm	W/in ²	W/cm ²	120V	240V
1	25.4	20	34	5.3	LDC00012	—
1½	38.1	20	23	3.5	LDC00014	—
2	50.8	32	27	4.2	LDC00015	—
2	50.8	40	34	5.3	LDC00016	—
2	50.8	50	42	6.6	LDC00017	—
2½	63.5	30	19	3.0	LDC00018	—
3	76.2	32	16	2.5	LDC00019	—
3	76.2	50	25	3.9	LDC00020	—
3½	88.9	80	34	5.3	LDC00021	—
4	101.6	100	36	5.6	LDC00022	LDC00023
5	127.0	125	35	5.5	LDC00024	—
6	152.4	150	35	5.4	LDC00025	LDC00026
7	177.8	100	20	3.0	LDC00027	LDC00028
8	203.2	200	34	5.3	LDC00029	LDC00030
10	254.0	250	34	5.2	LDC00031	LDC00032



Note: Part Numbers above are for Low Density Cartridge Heaters terminated with Type F flexible leads, 10" long. See pages 2-39 through 2-57 for other terminations.

Low-Density Cartridge Heaters are made-to-order only. Standard lead time is 3 weeks.

Custom Engineered/Manufactured Low-Density Cartridge Heaters

Refer to ordering information on page 2-38.

Standard (Non-Stock) Low-Density Cartridge Heaters

3/8" Diameter Actual .372" (9.45 mm)

Sheath Length		Watts	Watt Density		Part Number	
in	mm		W/in ²	W/cm ²	120V	240V
1½	38.1	15	13	2.0	LDC00033	—
1½	38.1	40	34	5.3	LDC00034	—
2	50.8	50	28	4.4	LDC00035	—
2½	63.5	75	32	4.9	LDC00036	—
2½	63.5	100	42	6.6	LDC00037	—
3	76.2	100	34	5.3	LDC00038	—
3½	88.9	120	34	5.3	LDC00039	LDC00040
4	101.6	75	18	2.8	LDC00041	LDC00042
4	101.6	130	32	4.9	LDC00043	LDC00044
4	101.6	150	36	5.6	LDC00045	LDC00046
4	101.6	180	44	6.8	LDC00047	LDC00048
4½	114.3	75	16	2.5	LDC00049	LDC00050
4½	114.3	150	32	4.9	LDC00051	LDC00052
5	127.0	150	28	4.4	LDC00053	LDC00054
5	127.0	200	38	5.8	LDC00055	LDC00056
5½	139.7	200	34	5.3	LDC00057	LDC00058
6	152.4	225	35	5.4	LDC00059	LDC00060
6	152.4	250	39	6.0	LDC00061	LDC00062
7	177.8	200	26	4.0	LDC00063	LDC00064
7	177.8	265	35	5.4	LDC00065	LDC00066
8	203.2	300	34	5.3	LDC00067	LDC00068
9	228.6	350	35	5.4	LDC00069	LDC00070
9½	241.3	300	28	4.4	LDC00071	LDC00072
10	254.0	375	34	5.2	LDC00073	LDC00074
12	304.8	425	31	4.9	LDC00075	LDC00076
12	304.8	450	33	5.1	LDC00077	LDC00078
12	304.8	475	35	5.4	LDC00079	LDC00080
12	304.8	500	37	5.7	LDC00081	LDC00082
14	355.6	500	31	4.9	LDC00083	LDC00084
16	406.4	550	30	4.7	LDC00085	LDC00086
20	508.0	200	9	1.3	LDC00087	LDC00088
20	508.0	650	28	4.4	LDC00089	LDC00090
22	558.8	800	32	4.9	—	LDC00091
24	609.6	750	27	4.2	—	LDC00092

1/2" Diameter Actual .496" (12.60 mm)

Sheath Length		Watts	Watt Density		Part Number	
in	mm		W/in ²	W/cm ²	120V	240V
1½	38.1	60	38	5.9	LDC00093	—
2	50.8	75	32	4.9	LDC00094	—
2½	63.5	40	13	2.0	LDC00095	—
2½	63.5	125	40	6.2	LDC00096	—
3	76.2	150	38	5.9	LDC00097	LDC00098
3½	88.9	150	32	4.9	LDC00099	LDC00100
3¾	98.4	90	17	2.6	LDC00101	LDC00102
4	101.6	180	33	5.1	LDC00103	LDC00104
4½	114.3	200	32	4.9	LDC00105	—
5	127.0	200	28	4.4	LDC00106	LDC00107
5½	139.7	300	38	5.9	LDC00108	LDC00109
6	152.4	150	17	2.7	LDC00110	LDC00111
6	152.4	250	29	4.5	LDC00112	LDC00113
6	152.4	300	35	5.4	LDC00114	LDC00115
6½	165.1	300	32	4.9	LDC00116	LDC00117
7	177.8	275	27	4.2	LDC00118	LDC00119
7	177.8	350	34	5.3	LDC00120	LDC00121
7½	190.5	350	32	4.9	LDC00122	LDC00123
8	203.2	400	34	5.3	LDC00124	LDC00125
8	203.2	425	36	5.6	LDC00126	LDC00127
8½	215.9	400	32	4.9	LDC00128	LDC00129
9	228.6	450	34	5.2	LDC00130	LDC00131
10	254.0	500	34	5.2	LDC00132	LDC00133
10½	266.7	500	32	4.9	LDC00134	LDC00135
11	279.4	550	33	5.2	LDC00136	LDC00137
12	304.8	500	28	4.3	LDC00138	LDC00139
12	304.8	600	33	5.1	LDC00140	LDC00141
14	355.6	600	28	4.4	LDC00142	LDC00143
15	381.0	650	29	4.4	LDC00144	LDC00145
15	381.0	750	33	5.1	LDC00146	LDC00147
16	406.4	500	21	3.2	LDC00148	LDC00149
16	406.4	675	28	4.3	LDC00150	LDC00151
18	457.2	725	26	4.1	LDC00152	LDC00153
18	457.2	800	29	4.5	—	LDC00154
20	508.0	750	24	3.8	LDC00155	LDC00156
21	533.4	750	23	3.6	LDC00157	LDC00158
24	609.6	500	14	2.1	LDC00159	LDC00160
24	609.6	1000	27	4.2	—	LDC00161
25	635.0	1100	29	4.4	—	LDC00162



Note: Part Numbers above are for Low Density Cartridge Heaters terminated with Type F flexible leads, 10" long. See pages 2-39 through 2-57 for other terminations.

Low-Density Cartridge Heaters are made-to-order only. **Standard lead time is 3 weeks.**

Custom Engineered/Manufactured Low-Density Cartridge Heaters

Refer to ordering information on page 2-38.



Standard (Non-Stock) Low-Density Cartridge Heaters

5/8" Diameter Actual .621" (15.77 mm)

3/4" Diameter Actual .745" (18.92 mm)

Sheath Length		Watts	Watt Density		Part Number	
in	mm		W/in ²	W/cm ²	120V	240V
1½	38.1	100	51	7.9	LDC00163	LDC00164
2	50.8	100	34	5.3	LDC00165	LDC00166
2½	63.5	80	20	3.2	LDC00167	LDC00168
2½	63.5	150	38	5.9	LDC00169	LDC00170
3	76.2	175	36	5.5	LDC00171	LDC00172
3½	88.9	190	32	5.0	LDC00173	LDC00174
4	101.6	200	29	4.5	LDC00175	LDC00176
4½	114.3	240	31	4.7	LDC00177	LDC00178
4½	114.3	275	35	5.4	LDC00179	LDC00180
5	127.0	200	23	3.5	LDC00181	LDC00182
5	127.0	250	28	4.4	LDC00183	LDC00184
5	127.0	375	42	6.6	LDC00185	LDC00186
5½	139.7	200	20	3.2	LDC00187	LDC00188
5½	139.7	285	29	4.5	LDC00189	LDC00190
5½	139.7	510	52	8.1	LDC00191	—
5½	149.2	350	33	5.1	LDC00192	LDC00193
6	152.4	200	19	2.9	LDC00194	LDC00195
6	152.4	300	28	4.3	LDC00196	LDC00197
6	152.4	350	32	5.0	LDC00198	LDC00199
6½	165.1	350	30	4.6	LDC00200	LDC00201
7	177.8	375	29	4.6	LDC00202	LDC00203
8	203.2	400	27	4.2	LDC00204	LDC00205
8½	215.9	425	27	4.2	LDC00206	LDC00207
9	228.6	450	27	4.2	LDC00208	LDC00209
9½	241.3	475	27	4.2	LDC00210	LDC00211
10	254.0	500	27	4.2	LDC00212	LDC00213
11	279.4	550	27	4.1	LDC00214	LDC00215
12	304.8	250	11	1.7	LDC00216	LDC00217
12	304.8	500	22	3.4	LDC00218	LDC00219
12	304.8	600	27	4.1	LDC00220	LDC00221
12	304.8	700	31	4.8	LDC00222	LDC00223
12½	314.3	450	19	3.0	LDC00224	LDC00225
14	355.6	700	26	4.1	LDC00226	LDC00227
15	381.0	750	26	4.1	LDC00228	LDC00229
16	406.4	800	26	4.1	LDC00230	LDC00231
17	431.8	1000	31	4.8	LDC00232	LDC00233
18	457.2	725	21	3.3	LDC00234	LDC00235
18	457.2	800	23	3.6	LDC00236	LDC00237
20	508.0	900	24	3.6	LDC00238	LDC00239
21	533.4	1000	25	3.9	—	LDC00240
22	558.8	2000	47	7.3	—	LDC00241
24	609.6	2000	43	6.7	—	LDC00242
25	635.0	768	16	2.5	LDC00243	—
25	635.0	1100	23	3.5	—	LDC00244
25	635.0	1500	31	4.8	LDC00245	LDC00246
27	685.8	1200	23	3.6	LDC00247	—
28	711.2	2000	37	5.7	—	LDC00248
30	762.0	2000	35	5.4	—	LDC00249
31	787.4	2000	33	5.2	—	LDC00250
34	863.6	2000	30	4.7	—	LDC00251
36	914.4	2000	29	4.4	—	LDC00252
38	965.2	2000	27	4.2	—	LDC00253
38½	979.5	1200	16	2.5	LDC00254	—

Sheath Length		Watts	Watt Density		Part Number	
in	mm		W/in ²	W/cm ²	120V	240V
3	76.2	225	38	5.9	LDC00255	LDC00256
3½	88.9	225	32	4.9	LDC00257	LDC00258
3½	88.9	250	35	5.5	LDC00259	LDC00260
4	101.6	300	36	5.6	LDC00261	LDC00262
5	127.0	350	33	5.1	LDC00263	LDC00264
6	152.4	170	13	2.0	LDC00265	LDC00266
6	152.4	350	27	4.2	LDC00267	LDC00268
6	152.4	400	31	4.8	LDC00269	LDC00270
7	177.8	350	23	3.5	LDC00271	LDC00272
7	177.8	450	29	4.6	LDC00273	LDC00274
7	177.8	535	35	5.4	LDC00275	LDC00276
8	203.2	350	20	3.1	LDC00277	LDC00278
8	203.2	500	28	4.4	LDC00279	LDC00280
8	203.2	600	34	5.3	LDC00281	LDC00282
8½	215.9	675	36	5.6	LDC00283	LDC00284
9	228.6	350	17	2.7	LDC00285	LDC00286
9	228.6	550	27	4.3	LDC00287	LDC00288
9½	241.3	575	27	4.2	LDC00289	LDC00290
10	254.0	600	27	4.2	LDC00291	LDC00292
10	254.0	800	36	5.5	LDC00293	LDC00294
11	279.4	675	27	4.2	LDC00295	LDC00296
12	304.8	750	28	4.3	LDC00297	LDC00298
12	304.8	1000	37	5.7	LDC00299	LDC00300
13½	342.9	600	20	3.0	LDC00301	LDC00302
14	355.6	1000	31	4.9	LDC00303	LDC00304
16	406.4	950	26	4.0	LDC00305	LDC00306
18	457.2	950	23	3.6	LDC00307	LDC00308
18	457.2	1100	27	4.1	—	LDC00309
20	508.0	1000	22	3.4	LDC00310	LDC00311
21	533.4	1150	24	3.7	LDC00312	LDC00313
30	762.0	1800	26	4.0	—	LDC00314
31	787.4	1800	25	3.9	—	LDC00315



Note: Part Numbers above are for Low Density Cartridge Heaters terminated with Type F flexible leads, 10" long. See pages 2-39 through 2-57 for other terminations.

Low-Density Cartridge Heaters are made-to-order only. **Standard lead time is 3 weeks.**

Custom Engineered/Manufactured Low-Density Cartridge Heaters

Refer to ordering information on page 2-38.

Cartridge Heaters



Low-Density

Standard (Non-Stock) Low-Density Cartridge Heaters

7/8" Diameter Actual .870" (22.10 mm)

Sheath Length		Watts	Watt Density		Part Number	
in	mm		W/in ²	W/cm ²	120V	240V
3½	88.9	250	30	4.7	LDC00316	LDC00317
4	101.6	300	31	4.8	LDC00318	LDC00319
5	127.0	400	32	5.0	LDC00320	LDC00321
6	152.4	475	31	4.9	LDC00322	LDC00323
7	177.8	525	29	4.6	LDC00324	LDC00325
8	203.2	550	27	4.1	LDC00326	LDC00327
10	254.0	600	23	3.6	LDC00328	LDC00329
11	279.4	600	21	3.2	LDC00330	LDC00331
11	279.4	700	24	3.8	LDC00332	LDC00333
12	304.8	850	27	4.2	LDC00334	LDC00335
13	330.2	900	26	4.1	LDC00336	LDC00337
15	381.0	950	24	3.7	LDC00338	LDC00339
18	457.2	1000	21	3.2	LDC00340	LDC00341
21½	546.1	1000	17	2.7	—	LDC00342

1" Diameter Actual .995" (25.27 mm)

Sheath Length		Watts	Watt Density		Part Number	
in	mm		W/in ²	W/cm ²	120V	240V
3	76.2	250	32	4.9	LDC00373	LDC00374
4	101.6	300	27	4.2	LDC00375	LDC00376
5	127.0	375	27	4.1	LDC00377	LDC00378
6	152.4	500	29	4.5	LDC00379	LDC00380
8	203.2	600	25	3.9	LDC00381	LDC00382
9	228.6	700	26	4.1	LDC00383	LDC00384
10	254.0	800	27	4.2	LDC00385	LDC00386
10¾	273.1	600	19	2.9	LDC00387	LDC00388
10¾	273.1	850	26	4.1	LDC00389	LDC00390
12	304.8	1000	28	4.3	LDC00391	LDC00392
14	355.6	1100	26	4.0	LDC00393	LDC00394
18	457.2	1250	23	3.5	LDC00395	LDC00396
22¼	565.2	1000	15	2.3	LDC00397	LDC00398
23	584.2	1000	14	2.2	LDC00399	LDC00400
23½	596.9	1500	21	3.2	—	LDC00401
24	609.6	1500	20	3.1	—	LDC00402

1-1/4" Diameter Actual 1.250" (31.75 mm)

Sheath Length		Watts	Watt Density		Part Number	
in	mm		W/in ²	W/cm ²	120V	240V
3¼	82.6	400	37	5.7	LDC00403	LDC00404
5	127.0	450	25	3.9	LDC00405	LDC00406
6	152.4	500	23	3.6	LDC00407	LDC00408
6	152.4	800	37	5.7	LDC00409	LDC00410
7	177.8	550	22	3.3	LDC00411	LDC00412
7	177.8	1000	39	6.1	LDC00413	LDC00414
9	228.6	675	20	3.1	LDC00415	LDC00416
10	254.0	1000	27	4.2	LDC00417	LDC00418
12	304.8	1000	22	3.4	LDC00419	LDC00420
14	355.6	2000	38	5.8	—	LDC00421
15	381.0	1250	22	3.4	—	LDC00422
16½	419.1	1000	16	2.5	LDC00423	LDC00424
22½	571.5	2200	25	3.9	—	LDC00425
24	609.6	2400	26	4.0	—	LDC00426



Note: Part Numbers above are for Low-Density Cartridge Heaters terminated with Type F flexible leads, 10" long.

Low-Density Cartridge Heaters are made-to-order only. Standard lead time is 3 weeks.

See pages 2-39 through 2-57 for other terminations.

Ordering Information

Catalog Heaters

Order by Catalog Part Number from the Standard Sizes and Ratings List on the preceding pages. Note that Part Numbers shown are for heaters with Type F Termination (10" leads).

Available Terminations and Optional Features can be found on pages 2-39 through 2-60.

Custom Engineered/Manufactured Heaters

Because an electric heater can be very application specific, for sizes and ratings not listed, **TEMPCO** will design and manufacture a Low-Density Cartridge Heater to meet your requirements. **Standard lead time is 3 weeks.**

Please Specify the following:

- Diameter
- Length
- Wattage
- Voltage
- Termination types (see pages 2-39 through 2-51)
- Options/Special Features (see pages 2-52 through 2-60)
- Lead Length
- Cable/Braid length
- Application Type
- Operating Temperature



Tempco Offers Innovative Cartridge Heater Terminations Focused on Providing Maximum Performance Under a Diverse Segment of Demanding Applications

Cartridge Heater Terminations Can be Elusive to Define and Are Often Overlooked

To ensure maximum efficiency and reliable cartridge heater service, evaluate your existing operating conditions and proceed to select the best suited termination(s) for your application.

Failure to evaluate the operating conditions and the environment of a cartridge heater application and/or improper termination selection will compromise the operating reliability and functional life of the cartridge heater, resulting in costly machine downtime and loss of revenue due to lack of productivity.

The synergy between the cartridge heater termination and the application will result in reduced operating cost, increased productivity, optimized performance and improved customer satisfaction.

Take Advantage of Tempco's Innovative Cartridge Heater Terminations.

We offer a selection of over 40 standard terminations specifically designed to address the operating requirements of a multitude of diverse applications requiring protection against the following conditions:

- **Abrasion**
- **Moisture Resistance**
- **Double-End Powerleads**
- **Locating Ring or Bushings**
- **NPT or Bulkhead Fittings**
- **Built-In Thermocouples & Thermostats**
- **Electrical Boxes**
- **Contamination**
- **High Temperatures**
- **Mounting Flanges**
- **Pull Straps**
- **Flexing**

In addition, there are many cartridge heater adaptations to facilitate their use:
 Refer to pages 2-39 through 2-60 for complete specifications and details on all available terminations and options.

A Wise Man Once Said . . .

“A Cartridge Heater is Only As Good as the Termination that Powers It.”

Standard Termination — HDC and HDM Hi-Density Cartridge Heaters



Available through the Hi-Density Cartridge Heater Terminator Program for Same or Next Day Shipping

Type N External Pins with Leads

Available on HDC and HDM cartridge heaters

Flexible stranded lead wires have fiberglass insulation and are connected to 1-1/4" (32 mm) long solid conductors. Silicone rubber coated fiberglass sleeving insulates the pin/lead wire connection.

- Nominal 3/8" unheated section at the lead end is required.
- Standard lead wire temperature rating: 482°F (250°C)
- **Standard 10" (254 mm) leads.** Specify longer leads.

Standard Termination — LDC Low-Density Cartridge Heaters

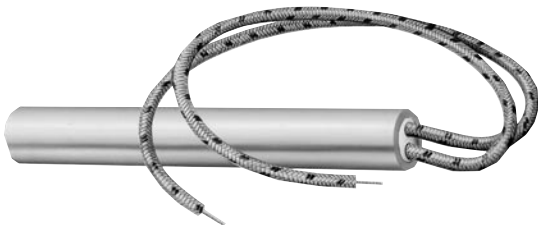

Type F Internally Connected Flexible Leads

Available on HDC, HDM and LDC Cartridge Heaters

The fiberglass lead wires are internally connected to the terminal pins. This lead termination provides flexibility, permitting the lead wires to be sharply bent as they exit the heater.

- Minimum 3/8" up to 1" unheated section at the lead end is required.
- Standard lead wire temperature rating for HDC and HDM cartridge heaters is 842°F (450°C)
- Standard lead wire temperature rating for LDC cartridge heaters is 482°F (250°C)
- **Standard 10" (254 mm) leads.** Specify longer leads. For HDC & HDM heaters, leads longer than 60" require a splice.

Cartridge Heater — Moisture Resistant Terminations

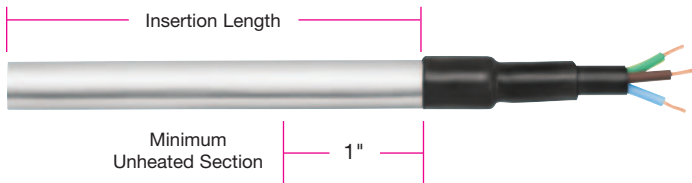

Type M1 Polyolefin Liquid Barrier

Available on HDC, HDM, and LDC cartridge heaters

A liquid barrier used for low temperature applications primarily in refrigeration or food service applications. The seal bonds to both the heater and the leads.

- Minimum 1" unheated section at the lead end is required.
- Three conductor SJO type cord.
- Available only in certain diameters. Heaters smaller than 1/2" diameter require an adapter.
- **Standard 10" (254 mm) leads. Specify longer leads.**

Type M2 Potted End Seal

Available on HDC, HDM and LDC cartridge heaters

Potted end seals help to protect the heater from moisture or contamination from plastic material, cleaning solvents, or oils. The bottom end disc seal is welded in.

M2A Cement potting with silicone varnish. Fiberglass lead wires externally connected.

- Cement potting temperature rating: 1000°F (538°C)
- Standard lead wire temperature rating: 482°F (250°C)

M2B Silicone rubber potting. Silicone rubber lead wires internally connected.

- Silicone rubber potting temperature rating: 450°F (232°C)
- Standard lead wire temperature rating: 392°F (200°C)

M2C High temperature epoxy potting. Teflon® lead wires internally connected.

- High temp. epoxy potting temp. rating: 450°F (232°C)
- Standard lead wire temperature rating: 392°F (200°C)

M2D Low temperature epoxy potting. Teflon® lead wires internally connected.

- Low temp. epoxy potting temp. rating: 266°F (130°C), UL rated to 194°F (90°C)
- Standard lead wire temperature rating: 392°F (200°C)

M2E Cement potting with silicone varnish. Fiberglass lead wires internally connected.

- Cement potting temperature rating: 1000°F (548°C)
- Standard lead wire temperature rating: 482°F (250°C)
- Minimum of 3/8" up to 1" unheated section at the lead end is required.
- **Standard 10" (254 mm) leads. Specify longer leads.**

Type M3 Teflon® End Plug Seal

Available on HDC and HDM cartridge heaters

A moisture resistant Teflon® seal that is swaged in during the manufacturing process with Teflon® insulated lead wire.

- Minimum 3/8" up to 1" unheated section at the lead end is required.
- Teflon® seal temperature rating: 392°F (200°C)
- Standard lead wire temperature rating: 392°F (200°C)
- **Standard 10" (254 mm) leads. Specify longer leads. Leads longer than 60" require a splice.**

TYPE M2A



TYPE M2B, M2C, M2D and M2E



 M2A and M2E are available through the Hi-Density Cartridge Heater Terminator Program for 2nd or 3rd Day Shipping



Cartridge Heater — Moisture Resistant Terminations

Type SA Sealed Corrugated Armor Cable

Available on 1/2" Diameter and Larger HDC, HDM and LDC cartridge heaters

A liquid-proof stainless steel corrugated metal hose is silver brazed to the end of the cartridge heater. The end disc of the heater is also welded or brazed. This termination provides a positive seal against moisture and contamination entering the heater.

- ▶ Minimum 3/8" up to 1" unheated section at the lead end is required.
- ▶ Standard fiberglass lead wire temperature rating
HDC and HDM: 842°F (450°C), LDC: 482°F (250°C)
- ▶ **Standard 10" (254 mm) cable over 12" (305 mm) leads.**
Specify longer leads or cable.



Cartridge Heater — Flexible Spring Abrasion Resistant Terminations

Type S1 Flexible Spring

Available on HDC, HDM, and LDC cartridge heaters.

The leads are reinforced with a steel spring for applications with extreme flexing. The spring is mechanically fastened or silver brazed.

S1A Mechanically fastened spring.

S1B Silver brazed spring.

- ▶ Minimum 3/8" up to 1" unheated section at the lead end is required.
- ▶ Standard fiberglass lead wire temperature rating
HDC and HDM: 842°F (450°C), LDC: 482°F (250°C)
- ▶ **Standard 10" (254 mm) leads. Specify longer leads.**

Dimensions for Type S1

	Diameter		Fig.	"A" Dim.		"B" Dim.	
	in	mm		in	mm	in	mm
Hi-Density Cartridge Heaters	1/4	6.35	1	11/16	17.46	5/16	7.94
	5/16	7.94	1	11/16	17.46	7/16	11.11
	3/8	9.53	1	11/16	17.46	7/16	11.11
	1/2	12.70	1	13/16	20.64	9/16	14.29
	5/8	15.88	1	1	25.40	3/4	19.05
	3/4	19.05	1	1-1/4	31.75	7/8	22.23
	1	25.40	2	5/8	15.88	5/8	15.88
Low-Density Cartridge Heaters	3/16	4.76	—	—	—	—	—
	1/4	6.35	1	11/16	17.46	5/16	7.94
	3/8	9.53	1	11/16	17.46	7/16	11.11
	1/2	12.70	1	13/16	20.64	9/16	14.29
	5/8	15.88	2	7/16	11.11	9/16	14.29
	3/4	19.05	2	1/2	12.70	9/16	14.29
	7/8	22.23	2	5/8	15.88	9/16	14.29
	1	25.40	2	5/8	15.88	5/8	15.88
	1-1/4	31.75	2	5/8	15.88	5/8	15.88

TYPE S1 Fig. 1

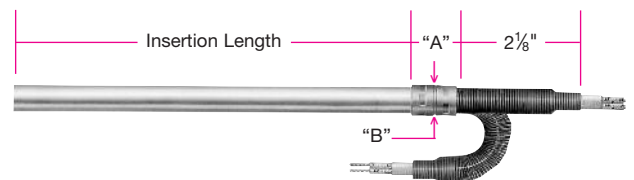

TYPE S1 Fig. 2

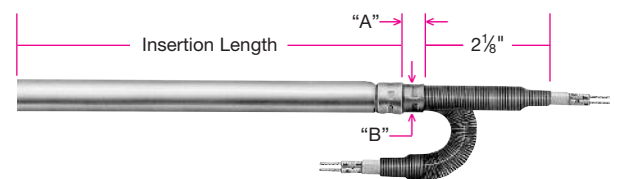

Abrasion Resistant Terminations

Cartridge Heater — Flexible Braid Abrasion Resistant Terminations

TYPE W Fig. 1

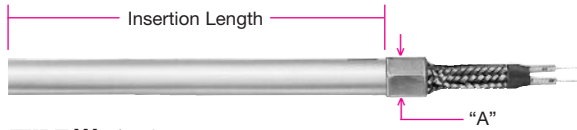

TYPE W Fig. 2

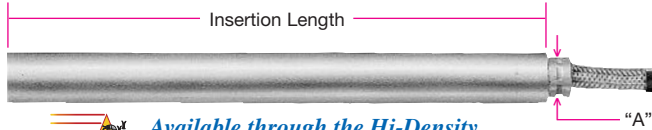

Available through the Hi-Density Cartridge Heater Terminator Program for 2nd or 3rd Day Shipping

Diameter		Fig.	"A" Dim./HD		"A" Dim./LD	
in	mm		in	mm	in	mm
3/16	4.76	1	—	—	1/4	6.35
1/4	6.35	1	5/16	7.94	5/16	7.94
5/16	7.94	1	3/8	9.53	—	—
3/8	9.53	2	3/8	9.53	3/8	9.53
1/2	12.70	2	7/16	11.11	7/16	11.11
5/8	15.88	2	9/16	14.29	9/16	14.29

Type W Wire Braided Leads

Available on HDC, HDM, and LDC cartridge heaters

Stainless steel braid over fiberglass leads offers sharp bending not possible with armor cable, as well as abrasion protection.

- Minimum 3/8" up to 1" unheated section at the lead end is required.
- Standard lead wire temperature rating
HDC and HDM: 842°F (450°C), LDC: 482°F (250°C)
- **Standard 10" (254 mm) braid over 12" (305 mm) leads.**
Specify longer braid/leads.

Diameter		Fig.	"A" Dim./HD		"A" Dim./LD	
in	mm		in	mm	in	mm
3/4	19.05	2	9/16	14.29	9/16	14.29
7/8	22.23	2	—	—	9/16	14.29
1	25.40	2	9/16	14.29	9/16	14.29
1-1/4	31.75	2	—	—	9/16	14.29

Type W2 Embedded Wire Braided Leads

Available on HDC, HDM and LDC cartridge heaters

Stainless Steel braid embedded into seal offers moisture resistance and abrasion protection.

W2A Fiberglass Leads with Cement Potting

- Cement potting temperature rating: 1000°F (538°C)
- Standard lead wire temperature rating: 482°F (250°C)

W2B Teflon® Leads with High Temperature Epoxy

- High temperature epoxy temp. rating: 450°F (232°C)
- Standard lead wire temperature rating: 392°F (200°C)

W2C Teflon® Leads with Low Temperature Epoxy

- Low temperature epoxy temp. rating: 266°F (130°C)
UL rated to 194°F (90°C)
- Standard lead wire temperature rating: 392°F (200°C)
- Minimum 3/8" up to 1" unheated section at the lead end is required.
- **Standard 10" (254 mm) braid over 12" (305 mm) leads.**
Specify longer braid/leads.



Type W3 Swaged-In Wire Braided Leads

Available on HDC and HDM cartridge heaters

Stainless steel braid over fiberglass leads offers sharp bending not possible with armor cable, as well as abrasion protection. In addition, Type W3 offers contamination resistance due to the Teflon® seal required for holding the wire braid.

- Minimum 3/8" up to 1" unheated section at the lead end is required.
- Teflon® Seal temperature rating: 392°F (200°C)
- Standard lead wire temperature rating: 842°F (450°C)
- **Standard 10" (254 mm) braid over 12" (305 mm) leads.**
Specify longer braid/leads.



[View Product Inventory @ www.tempco.com](http://www.tempco.com)

Cartridge Heater — Armor Cable Abrasion Resistant Terminations

Type CS Straight Armor Cable Directly Attached to Sheath

Available on HDC, HDM, and LDC cartridge heaters

The armor cable is directly attached to the cartridge heater, eliminating the coupling, to maintain an overall diameter equal to or smaller than the cartridge diameter.

CSA Galvanized armor cable – minimum diameter: 5/16"

CSB Stainless steel armor cable – minimum diameter: 5/16"

- Minimum 3/8" up to 1" unheated section at the lead end is required.
- Heaters with an OD of 3/4" or larger require reducing diameter washer
- Standard fiberglass lead wire temperature rating
HDC and HDM: 842°F (450°C), LDC: 482°F (250°C)
- **Standard 10" (254 mm) cable over 12" (305 mm) leads.**
Specify longer leads or cable.



Type C1 Straight Armor Cable with Coupling

Available on HDC, HDM, or LDC cartridge heaters

Armor cable provides the maximum in protection for abrasive, jagged environments. The coupling between the cartridge and the armor cable is mechanically fastened or silver brazed.

C1A Galvanized armor cable, mechanically fastened

C1B Stainless steel armor cable, mechanically fastened

- Standard fiberglass lead wire temperature rating
482°F (250°C)

C1C Galvanized armor cable, silver brazed

C1D Stainless steel armor cable, silver brazed

- Standard fiberglass lead wire temperature rating
HDC and HDM: 842°F (450°C), LDC: 482°F (250°C)

- Minimum 3/8" up to 1" unheated section at the lead end is required.

- **Standard 10" (254 mm) cable over 12" (305 mm) leads.**
Specify longer leads or cable.

TYPE C1 Fig. 1

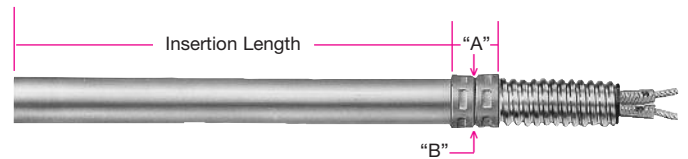

C1A and C1B are available through the Hi-Density Cartridge Heater Terminator Program for Same or Next Day Shipping

Dimensions for Type C1

	Diameter		Fig.	"A" Dim.		"B" Dim.		Cable Dia.
	in	mm		in	mm	in	mm	
Hi-Density Cartridge Heaters	1/4	6.35	1	11/16	17.46	5/16	7.94	1/4
	5/16	7.94	1	11/16	17.46	7/16	11.11	1/4
	3/8	9.53	1	11/16	17.46	7/16	11.11	3/8
	1/2	12.70	1	13/16	20.64	9/16	14.29	1/2
	5/8	15.88	1	1	25.40	3/4	19.05	1/2
	3/4	19.05	1	1-1/4	31.75	7/8	22.23	1/2
Low-Density Cartridge Heaters	1	25.40	2	5/8	15.88	5/8	15.88	1/2
	3/16	4.76	—	—	—	—	—	—
	1/4	6.35	1	11/16	17.46	5/16	7.94	1/4
	3/8	9.53	1	11/16	17.46	7/16	11.11	3/8
	1/2	12.70	1	13/16	20.64	9/16	14.29	1/2
	5/8	15.88	2	7/16	11.11	9/16	14.29	1/2
	3/4	19.05	2	1/2	12.70	9/16	14.29	1/2
	7/8	22.23	2	5/8	15.88	9/16	14.29	1/2
1	25.40	2	5/8	15.88	5/8	15.88	1/2	

TYPE C1 Fig. 2

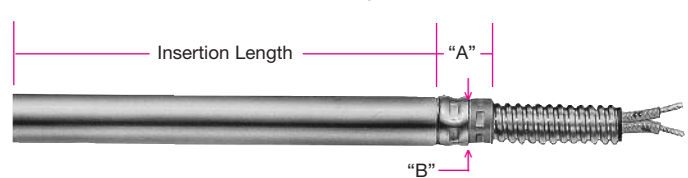

Right-Angle Terminations

Cartridge Heater — Plain Leads Right-Angle Terminations

TYPE R1 Fig. 1



TYPE R1 Fig. 2

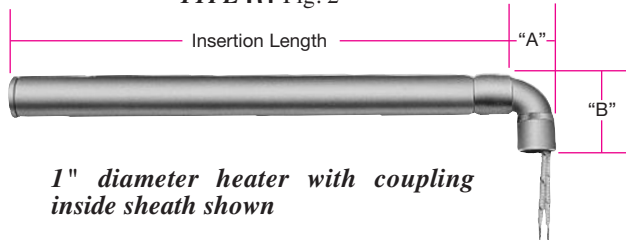

Type R1 Right-Angle Leads with Copper Elbow

Available on HDC, HDM, and LDC cartridge heaters

This termination is used when space is limited. The copper elbow is mechanically fastened or silver brazed.

R1A Mechanically fastened

R1B Silver brazed

➤ Minimum 3/8" up to 1" unheated section at the lead end is required.

➤ Standard fiberglass lead wire temperature rating
HDC and HDM: 842°F (450°C), LDC: 482°F (250°C)

➤ **Standard 10" (254 mm) leads. Specify longer leads.**

Dimensions for Type R1

	Diameter		Fig.	"A" Dim.		"B" Dim.	
	in	mm		in	mm	in	mm
Hi-Density Cartridge Heater	1/4	6.35	1	3/4	19.05	3/4	19.05
	5/16	7.94	1	15/16	23.81	15/16	23.81
	3/8	9.53	1	15/16	23.81	15/16	23.81
	1/2	12.70	1	1-1/4	31.75	1-1/4	31.75
	5/8	15.88	1	1-1/4	31.75	1-1/4	31.75
	3/4	19.05	1	1-3/4	44.45	1-1/4	31.75
	1	25.40	2	1-1/8	28.58	1-3/8	34.93
Low Density Cartridge Heater	3/16	4.76	—	—	—	—	—
	1/4	6.35	1	3/4	19.05	3/4	19.05
	3/8	9.53	1	15/16	23.81	15/16	23.81
	1/2	12.70	1	1-1/4	31.75	1-1/4	31.75
	5/8	15.88	2	11/16	17.46	1-1/4	31.75
	3/4	19.05	2	3/4	19.05	1-1/4	31.75
	7/8	22.23	2	3/4	19.05	1-3/8	34.93
	1	25.40	2	1-1/8	28.58	1-3/8	34.93
	1-1/4	31.75	2	1-1/8	28.58	1-3/8	34.93



Note: For Right-Angle Sheath Options, see page 2-53.



Cartridge Heater — Flexible Spring Abrasion Resistant Right-Angle Terminations

Type R2 Right-Angle Leads

Available on HDC, HDM, and LDC cartridge heaters

This termination is used when space is limited. Not suitable for abrasive environments. Same as C3 and W1 except plain leads. Various lead end finishes are available as listed below:

- R2A** Cement potting, no lead end disc
 - Cement potting temperature rating: 1000°F (538°C)
 - Standard fiberglass lead wire temperature rating: 482°F (250°C)
 - R2B** Cement potting, welded lead end disc
 - Cement potting temperature rating: 1000°F (538°C)
 - Standard fiberglass lead wire temperature rating: 482°F (250°C)
 - R2C** Silicone rubber potting, welded lead end disc
 - Silicone Rubber potting temperature rating: 450°F (232°C)
 - Standard silicone rubber lead wire temperature rating: 392°F (200°C)
 - R2D** High temperature epoxy potting, welded lead end disc
 - High Temperature epoxy potting temperature rating: 450°F (232°C)
 - Standard Teflon® lead wire temperature rating: 392°F (200°C)
 - R2E** Low temperature epoxy potting, welded lead end disc
 - Low Temperature epoxy potting temperature rating: 266°F (130°C)
 - Standard Teflon® lead wire temperature rating: 392°F (200°C)
- Minimum 3/8" up to 1" unheated section at the lead end is required.
- **Standard 10" (254 mm) leads. Specify other lead lengths.**

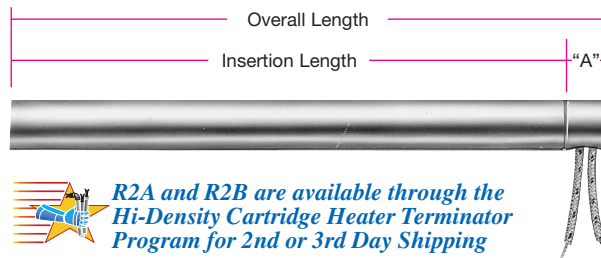

R2A and R2B are available through the Hi-Density Cartridge Heater Terminator Program for 2nd or 3rd Day Shipping

Dimensions for types R2

Diameter		Availability		"A" Dim.	
in	mm	HD	LD	in	mm
3/16	4.76	No	No	—	—
1/4	6.35	Yes	Yes	5/16	7.94
5/16	7.94	Yes	No	5/16	7.94
3/8	9.53	Yes	Yes	7/16	11.11
1/2	12.70	Yes	Yes	9/16	14.29
5/8	15.88	Yes	Yes	9/16	14.29
3/4	19.05	Yes	Yes	9/16	14.29
7/8	22.23	No	Yes	5/8	15.88
1	25.40	Yes	Yes	5/8	15.88
1-1/4	31.75	No	Yes	5/8	15.88

Type S2 Right-Angle Spring

Available on HDC, HDM, and LDC cartridge heaters

The leads are reinforced with a steel spring for applications with extreme flexing. The spring is mechanically fastened or silver brazed.

- S2A** Mechanically fastened spring
- S2B** Silver brazed spring
- Minimum 3/8" up to 1" unheated section at the lead end is required.
- Standard fiberglass lead wire temperature rating
HDC and HDM: 842°F (450°C), LDC: 482°F (250°C)
- **Standard 10" (254 mm) leads. Specify longer leads.**

Dimensions for Type S2

	Diameter		Fig.	"A" Dim.		"B" Dim.	
	in	mm		in	mm	in	mm
Hi-Density Cartridge Heaters	1/4	6.35	1	3/4	19.05	3/4	19.05
	5/16	7.94	1	15/16	23.81	15/16	23.81
	3/8	9.53	1	15/16	23.81	15/16	23.81
	1/2	12.70	1	1-1/4	31.75	1-1/4	31.75
	5/8	15.88	1	1-1/4	31.75	1-1/4	31.75
	3/4	19.05	1	1-3/4	44.45	1-1/4	31.75
	1	25.40	2	1-1/8	28.58	1-3/8	34.93
Low-Density Cartridge Heaters	3/16	4.76	—	—	—	—	—
	1/4	6.35	1	3/4	19.05	3/4	19.05
	3/8	9.53	1	15/16	23.81	15/16	23.81
	1/2	12.70	1	1-1/4	31.75	1-1/4	31.75
	5/8	15.88	2	11/16	17.46	1-1/4	31.75
	3/4	19.05	2	3/4	19.05	1-1/4	31.75
	7/8	22.23	2	3/4	19.05	1-3/8	34.93
	1	25.40	2	1-1/8	28.58	1-3/8	34.93
	1-1/4	31.75	2	1-1/8	28.58	1-3/8	34.93

TYPE S2 Fig. 1

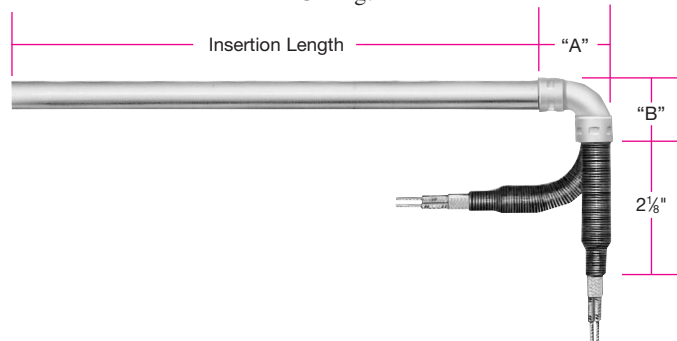

TYPE S2 Fig. 2

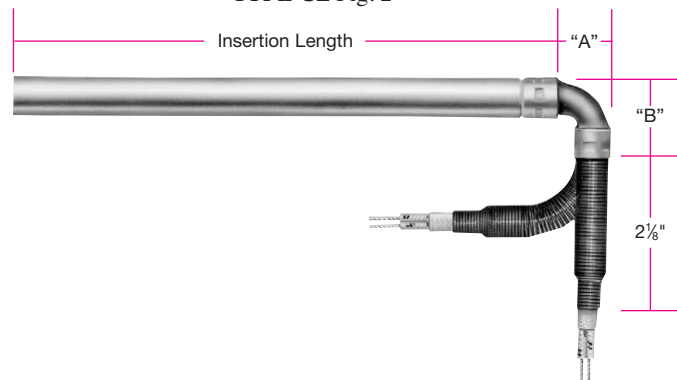

Right-Angle Terminations

Cartridge Heater — Flexible Braid Abrasion Resistant Right-Angle Terminations

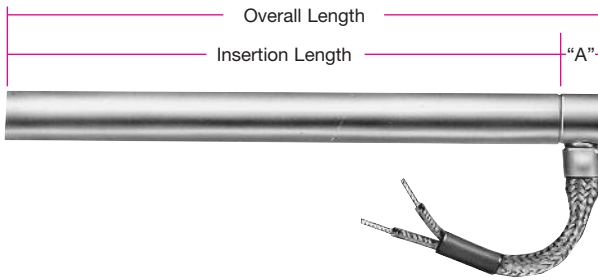

 Available through the Hi-Density Cartridge Heater Terminator Program for 2nd or 3rd Day Shipping

Dimensions for Type W1

Diameter		Availability		"A" Dim.	
in	mm	HD	LD	in	mm
3/16	4.76	No	No	—	—
1/4	6.35	Yes	Yes	5/16	7.94
5/16	7.94	Yes	No	5/16	7.94
3/8	9.53	Yes	Yes	7/16	11.11
1/2	12.70	Yes	Yes	9/16	14.29
5/8	15.88	Yes	Yes	9/16	14.29
3/4	19.05	Yes	Yes	9/16	14.29
7/8	22.23	No	Yes	5/8	15.88
1	25.40	Yes	Yes	5/8	15.88
1-1/4	31.75	No	Yes	5/8	15.88

Type W1 Right-Angle Wire Braided Leads

Available on HDC, HDM, and LDC cartridge heaters

Stainless steel braid over fiberglass leads for abrasion protection, mechanically crimped to the cartridge sheath at 90°. Wire braid offers extreme flexibility not possible with armor cable. Various lead end finishes are available as listed below.

W1A Cement potting and silicone varnish, no lead end disc.

- Cement potting temperature rating: 1000°F (538°C)
- Standard lead wire temperature rating: 482°F (250°C)

W1B Welded lead end disc.

- Cement potting temperature rating: 1000°F (538°C)
- Standard lead wire temperature rating: 482°F (250°C)
- Minimum 3/8" up to 1" unheated section at the lead end is required.
- **Standard** 10" (254 mm) braid over 12" (305 mm) leads. Specify longer braid or leads.



Note: For Right-Angle Sheath Options, see page 2-53.



Cartridge Heater — Armor Cable Abrasion Resistant Right-Angle Terminations

Type C2 Right-Angle Armor Cable with Copper Elbow

Available on HDC, HDM, and LDC cartridge heaters

Armor cable provides the maximum in protection for abrasive, jagged environments. The copper elbow between the cartridge and the armor cable is mechanically fastened or silver brazed.

- C2A** Galvanized armor cable, mechanically fastened
 - C2B** Stainless steel armor cable, mechanically fastened
 - C2C** Galvanized armor cable, silver brazed
 - C2D** Stainless steel armor cable, silver brazed
- Minimum 3/8" up to 1" unheated section at the lead end is required.
 - Standard fiberglass lead wire temperature rating
HDC and HDM: 842°F (450°C), LDC: 482°F (250°C)
 - **Standard 10" (254 mm) cable over 12" (305 mm) leads.**
Specify longer cable or leads.

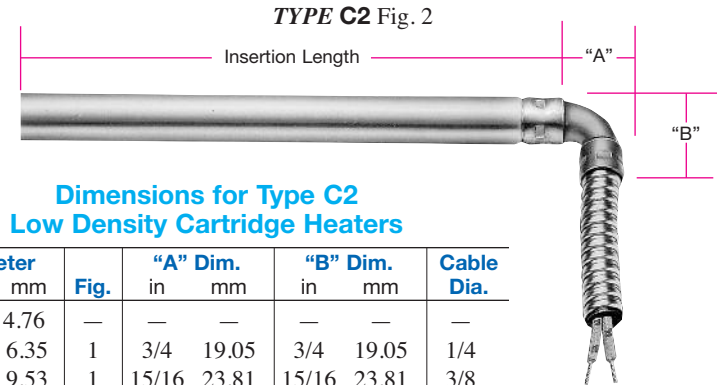
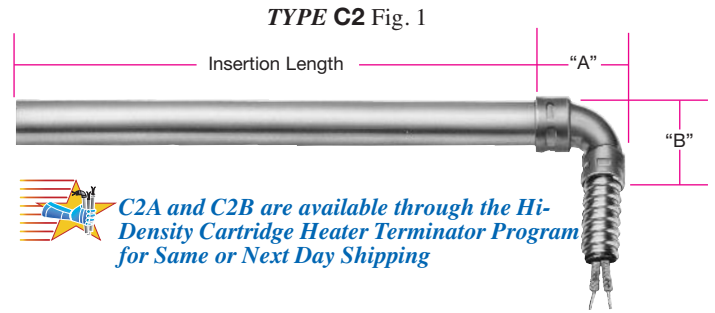

Dimensions for Type C2 Hi-Density Cartridge Heaters

Diameter		Fig.	"A" Dim.		"B" Dim.		Cable Dia.
in	mm		in	mm	in	mm	
1/4	6.35	1	3/4	19.05	3/4	19.05	1/4
5/16	7.94	1	15/16	23.81	15/16	23.81	1/4
3/8	9.53	1	15/16	23.81	15/16	23.81	3/8
1/2	12.70	1	1-1/4	31.75	1-1/4	31.75	1/2
5/8	15.88	1	1-1/4	31.75	1-1/4	31.75	1/2
3/4	19.05	1	1-3/4	44.45	1-1/4	31.75	1/2
1	25.40	2	1-1/8	28.58	1-3/8	34.93	1/2

Dimensions for Type C2 Low Density Cartridge Heaters

Diameter		Fig.	"A" Dim.		"B" Dim.		Cable Dia.
in	mm		in	mm	in	mm	
3/16	4.76	—	—	—	—	—	—
1/4	6.35	1	3/4	19.05	3/4	19.05	1/4
3/8	9.53	1	15/16	23.81	15/16	23.81	3/8
1/2	12.70	1	1-1/4	31.75	1-1/4	31.75	1/2
5/8	15.88	2	11/16	17.46	1-1/4	31.75	1/2
3/4	19.05	2	3/4	19.05	1-1/4	31.75	1/2
7/8	22.23	2	3/4	19.05	1-3/8	34.93	1/2
1	25.40	2	1-1/8	28.58	1-3/8	34.93	1/2
1-1/4	31.75	2	1-1/8	28.58	1-3/8	34.93	1/2

Type C3 Right-Angle Armor Cable

Available on HDC, HDM, and LDC cartridge heaters

Use this termination when space is limited and maximum protection is required. The armor cable is tack welded or silver brazed to the cartridge sheath at 90°. The sheath extension is potted with cement. Various lead end finishes are available as listed below.

- C3A** Cement potting and silicone varnish with no lead end disc, galvanized cable
 - C3B** Cement potting and silicone varnish with no lead end disc, stainless steel cable
 - C3C** Welded lead end disc, with galvanized cable
 - C3D** Welded lead end disc, with stainless steel cable
- Minimum 3/8" up to 1" unheated section at the lead end is required.
 - Cement potting temperature rating: 1000°F (538°C)
Standard fiberglass lead wire temperature rating: 482°F (250°C)
 - **Standard 10" (254 mm) armor cable over 12" (305 mm) leads.**
Specify longer cable or leads.

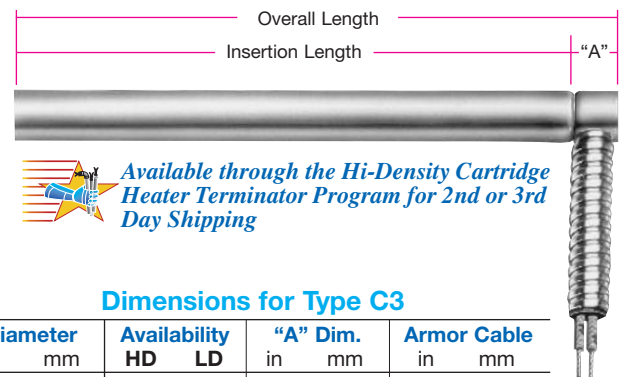

Dimensions for Type C3

Diameter	in	mm	Availability		"A" Dim.		Armor Cable	
			HD	LD	in	mm	in	mm
3/16	4.76		No	No	—	—	—	—
1/4	6.35		Yes	Yes	5/16	7.94	1/4	6.35
5/16	7.94		Yes	No	5/16	7.94	1/4	6.35
3/8	9.53		Yes	Yes	7/16	11.11	3/8	9.53
1/2	12.70		Yes	Yes	9/16	14.29	1/2	12.70
5/8	15.88		Yes	Yes	9/16	14.29	1/2	12.70
3/4	19.05		Yes	Yes	9/16	14.29	1/2	12.70
7/8	22.23		No	Yes	5/8	15.88	1/2	12.70
1	25.40		Yes	Yes	5/8	15.88	1/2	12.70
1-1/4	31.75		No	Yes	5/8	15.88	1/2	12.70

Cartridge Heater — Screw Terminations

Type T1 Screw Terminals

Available on LDC type cartridge heaters only

For use with leads, crimp terminals, or bus bars. Includes washers and nuts.

- Minimum 1/2" unheated section at the lead end is required.
- Diameters available: 3/4", 7/8", 1", and 1-1/4".
- **Standard:** screw #6-32 x 3/4" long



Diameter	in	3/4	7/8	1	1-1/4
	mm	19.05	22.23	25.40	31.75
"A" Dimension	in	3/8	7/16	1/2	1/2
	mm	9.53	11.11	12.70	12.70

Type T2 Screw Terminals

Available on HDC and HDM type cartridge heaters only

For use with leads, crimp terminals, or bus bars. Includes washers and nuts.

- Minimum 1/2" unheated section at the lead end is required.
- Diameters available: HD — 5/8", 3/4", 1"
HDM — 16 mm and 20 mm
- **Standard:** screw #8-32



Cartridge Heater — High Temperature Termination

Type B Heat Resistant Ceramic Bead Insulation

Available on HDC, HDM, and LDC cartridge heaters.

The ultimate in high temperature lead protection. Allows for the attachment of flexible leads to the heater away from the high heat area. Used when the ambient temperature exceeds 842°F (450°C).

- **Standard** 10" (254 mm) solid nickel pins insulated with ball and socket construction type ceramic beads



 Available through the Hi-Density Cartridge Heater Terminator Program for Same or Next Day Shipping

Type BL Heat Resistant Ceramic Bead Insulation with Leads

Available on HDC, HDM, and LDC cartridge heaters.

High temperature flexible leads are connected away from the high heat area.

- **Standard** 6" (254 mm) solid nickel pins insulated with ball and socket construction type ceramic beads and 10" (254 mm) fiberglass leads rated at 842°F (450°C). Specify longer leads.



 Available through the Hi-Density Cartridge Heater Terminator Program for Same or Next Day Shipping

Cartridge Heater — Double End Terminations

Type T4 Double End Terminal Pin

Available on HDC, HDM, and LDC cartridge heaters

For those applications in which wiring from both ends is an advantage. Various seals are available:

- T4A** Cement potting seal with silicone varnish
 - Cement potting temperature rating: 1000°F (538°C)
- T4B** High temp. moisture resistant epoxy seal
 - High temp. epoxy temp. rating: 450°F (232°C)
- T4C** Low temp. moisture resistant epoxy seal
 - Low temp. epoxy temp. rating: 266°F (130°C)
- Minimum 1" unheated section at each end is required.
- **Standard** terminal pin length is 2".



Type F1 Double End Flexible Leads

Available on HDC, HDM, and LDC cartridge heaters

For applications in which it is an advantage to wire from both ends. The leads are internally connected and can be bent sharply as they exit the potted ends. Various seals are available:

- F1A** Fiberglass leads with cement potting seal and silicone varnish
 - Cement potting temperature rating: 1000°F (532°C)
 - Standard lead wire temperature rating: 482°F (250°C)
- F1B** Teflon® leads with high temp. moisture resistant epoxy seal
 - High temp. epoxy temperature rating: 450°F (232°C)
 - Standard lead wire temperature rating: 392°F (200°C)
- F1C** Teflon® leads with low temp. moisture resistant epoxy seal
 - Low temp. epoxy temperature rating: 266°F (130°C)
 - Standard lead wire temperature rating: 392°F (200°C)
- Minimum 1" unheated section at each end is required.
- **Standard** 10" leads. Specify longer leads.
Leads longer than 60" require a splice.



Type T3 Double End Screw Terminals

Available on HDC, HDM, and LDC cartridge heaters from 1/2" to 1-1/4" diameter

A double ended heater with quick change wiring screw terminals. Includes zinc plated washers and nuts.

- Minimum 1/2" unheated section at each end is required.

Standard screw sizes:

- 1/2" diameter — #8-32 × 3/4" screws
- 5/8" to 1-1/4" diameter — #10-32 × 3/4" screws



Mounting Fitting Termination & Option

Cartridge Heater Termination — Single Ended National Pipe Thread (NPT) Fitting

TYPE CM Fig. 1 – Fitting Flush with Lead End of Sheath

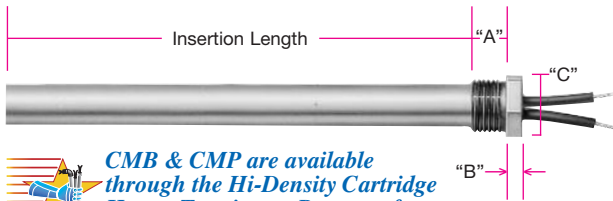

 **CMB & CMP are available through the Hi-Density Cartridge Heater Terminator Program for 2nd or 3rd Day Shipping**

NOTE: Stainless steel fittings are available through the Terminator program for heaters 1/2" diameter and larger.



Note: Fitting can be offset from end of sheath. See Figure 2, Single Threaded Mounting Options CMV and CMW below.

Standard NPT Bushing Dimensions
(Fig. 1 & Fig. 2)

Heater Diameter (in)	NPT Size	"A"	"B"	"C"
1/4	1/8-27	3/8	3/16	7/16
3/8	1/4-18	1/2	3/16	9/16
1/2	3/8-18	9/16	1/4	11/16
5/8	1/2-14	5/8	1/4	7/8
3/4	3/4-14	3/4	1/4	1-1/8
7/8	1-11 1/2	3/4	1/4	1-3/8
1	1-11 1/2	3/4	1/4	1-3/8
1-1/4	1 1/4-11 1/2	7/8	5/16	1-3/4

Type CM Single Threaded Fitting Mounting Termination Fitting Flush with Lead End of Sheath

Available on HDC, HDM, and LDC cartridge heaters

A single threaded pipe fitting is attached to the end of a cartridge heater to allow for installation into a threaded hole. Brass fittings are silver brazed and stainless steel fittings are heli-arc welded. Available with the potting seals listed in the table.

Potted end seals help to protect the heater from moisture or contamination from plastic material, cleaning solvents, or oils. The bushing cavity can be sealed with various materials such as:

CMA/CMN Low temperature epoxy potting — 266°F (130°C), UL rated to 194°F (90°C)
Teflon® leads internally connected, rated 392°F (200°C).

CMB/CMP Hi-temp cement potting with silicone varnish — 1000°F (538°C)
Fiberglass leads internally connected, rated 482°F (250°C).

CMC/CMQ Silicone rubber potting — 450°F (232°C)
Silicone rubber leads internally connected, rated 392°F (200°C).

CMD/CMR High temperature epoxy potting — 450°F (232°C)
Teflon® leads internally connected, rated 392°F (200°C).

➤ A minimum of 1/4" unheated section below the bushing is required.

➤ **Standard 10" (254 mm) leads. Specify longer leads.**

Type Codes for Single Threaded Fittings

Potting Seal Type	Fitting Material	
	Brass	Stainless Steel
Low Temp Epoxy	CMA	CMN
Hi-Temp Cement	CMB	CMP
Silicone Rubber	CMC	CMQ
Hi-Temp Epoxy	CMD	CMR

Single Ended National Pipe Thread (NPT) Fitting Option

TYPE CM Fig. 2 – Fitting Offset from Lead End of Sheath

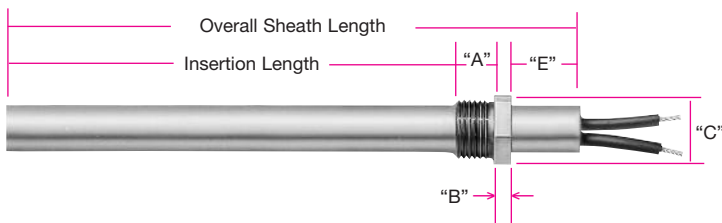

Type CM Single Threaded Fitting Mounting Option Fitting Offset from Lead End of Sheath

Available on HDC, HDM, and LDC cartridge heaters

This mounting option available with many terminations attaches a fitting offset from the lead end of the sheath. This option is useful when the lead wires need to be kept away from the heated area. Brass fittings are silver brazed and stainless steel fittings are offset heli-arc welded.

CMV Brass Fitting

CMW Stainless Steel Fitting

➤ Specify offset dimension "E" when ordering.

➤ A termination must be specified separately.

Hi-Density Cartridge Immersion Heater Specifically Designed for Heating Water & Other Liquids



See Page 2-23.

[View Product Inventory @ www.tempco.com](http://www.tempco.com)

Cartridge Heater — Double Ended National Pipe Thread (NPT)

Type CN Double Threaded Fitting Mounting Termination Fitting Flush with Lead End of Sheath

Available on HDC, HDM, and LDC cartridge heaters

A double threaded pipe fitting is attached to the end of a cartridge heater to allow for installation into a threaded hole. Brass fittings are silver brazed and stainless steel fittings are heli-arc welded.

Standard NPT Bushing Dimensions

Heater Diameter (in)	NPT Size	"A"	"B"	"C"
1/4	1/8-27	3/8	1/4	7/16
3/8	1/4-18	1/2	1/4	9/16
1/2	3/8-18	9/16	1/4	11/16
5/8	1/2-14	5/8	5/16	7/8
3/4	3/4-14	3/4	3/8	1-1/8
7/8	1-11 1/2	3/4	3/8	1-3/8
1	1-11 1/2	3/4	3/8	1-3/8
1-1/4	1 1/4-11 1/2	7/8	1/2	1-3/4

Type Codes for Double Threaded Fittings

Potting Seal Type	Fitting Material	
	Brass	Stainless Steel
Low Temp Epoxy	CNA	CNN
Hi-Temp Cement	CNB	CNP
Silicone Rubber	CNC	CNQ
Hi-Temp Epoxy	CND	CNR

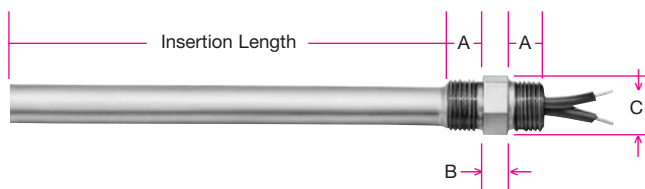

Potted end seals help to protect the heater from moisture or contamination from plastic material, cleaning solvents, or oils. The bushing cavity can be sealed with various materials such as:

CNA/CNN Low temperature epoxy potting — 266°F (130°C), UL rated to 194°F (90°C)
Teflon® leads internally connected, rated 392°F (200°C).

CNB/CNP Hi-temp cement potting w/ silicone varnish — 1000°F (538°C)
Fiberglass leads internally connected, rated 482°F (250°C).

CNC/CNQ Silicone rubber potting — 450°F (232°C)
Silicone rubber leads internally connected, rated 392°F (200°C).

CND/CNR High temperature epoxy potting — 450°F (232°C)
Teflon® leads internally connected, rated 392°F (200°C).

- A minimum of 1/4" unheated section below the bushing is required.
- Standard 10" (254 mm) leads. Specify longer leads.

Cartridge Heater Immersion Heater Top Hat Screw Plug Termination

Type TH Top Hat Screw Plug

Available on HDC (except 1/8") and HDM cartridge heaters

This heater has a header cap as an integral part of the fitting. Leads exit through small holes which are sealed with epoxy for moisture protection.

Low temperature epoxy potting — 266°F (130°C), UL rated to 194°F (90°C)

Teflon® leads internally connected, rated 392°F (200°C).

- Standard 10" (254 mm) leads. Specify longer leads.

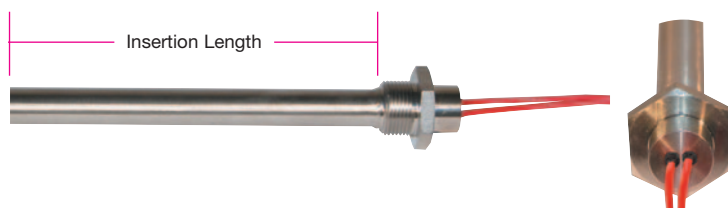

Cartridge Heater — Bulkhead Fitting Termination

Type BF Bulkhead Fitting

Available on HDC and LDC 1/2" and 5/8" cartridge heaters

A 5/8-18 UNF fitting is attached to the end of the cartridge heater to allow for mounting the heater to the wall of a tank or enclosure. Brass fittings are silver brazed and stainless steel fittings are heli-arc welded. Includes a copper washer and jam nut. The lead wires are internally connected. Available with the potting seals listed in the table.

Type Codes for Bulkhead Fittings

Potting Seal Type	Fitting Material	
	Brass	Stainless Steel
Low Temp Epoxy	BFA	BFJ
Silicone Rubber	BFB	BFK
Hi-Temp Epoxy	BFC	BFL

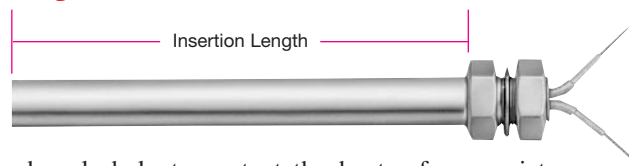

Potted end seals help to protect the heater from moisture or contamination from plastic material, cleaning solvents, or oils. The fitting cavity can be sealed with various materials such as:

BFA/BFJ Low temperature epoxy potting — 266°F (130°C), UL rated to 194°F (90°C)
Teflon® leads internally connected, rated 392°F (200°C).

BFB/BFK Silicone rubber potting — 450°F (232°C)
Silicone rubber leads internally connected, rated 392°F (200°C).

BFC/BFL High temperature epoxy potting — 450°F (232°C)
Teflon® leads internally connected, rated 392°F (200°C).

- A minimum of 1/4" unheated section below the bushing is required.
- Standard 10" (254 mm) leads. Specify longer leads.

Options

Cartridge Heater Mounting Flange Options

Type MFR Mounting Flange — Round

Available on HDC, HDM, and LDC cartridge heaters

Recommended for applications where excessive vibration exists and may cause the heater to back out of its mounting hole. The 16 ga. 304 SS flange is used as a means of securing the cartridge heater in place.

The default position of the flange is flush with the lead end. Specify the position of the flange when ordering.



Available through the Hi-Density Cartridge Heater Terminator Program for Same or Next Day Shipping with flush flange only

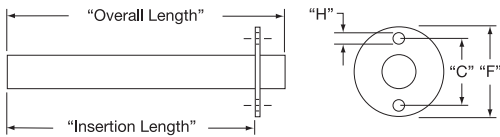

Standard Round Mounting Flanges

Heater Diameter in (mm)	"F"		"C"		"H"	
	in	mm	in	mm	in	mm
1/4 (6.35), 5/16 (7.94), 3/8 (9.53), 1/2 (12.70), 5/8 (15.88), 3/4 (19.05)	1-1/2	38.10	1-1/8	28.57	.156	3.97
7/8 (22.23), 1 (25.40), 1-1/4 (31.80)	2	50.80	1-5/8	41.28	.203	5.16



Note: 5/16" dia. cartridge heater can only be HDC; 7/8" and 1-1/4" can only be LDC.

Type MFH Mounting Flange — Hex

Available on HDC, HDM, and LDC cartridge heaters

A hex shape allows the possibility of using a wrench when removal is tight. The 16 ga. 304 SS flange is used as a means of securing the cartridge heater in place.

The default position of the flange is flush with the lead end. Specify the position of the flange when ordering.

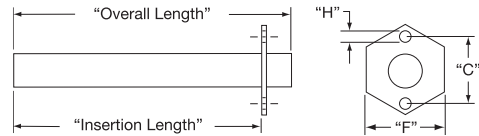

Standard Hex Mounting Flanges

Heater Diameter		"F"		"C"		"H"	
in	mm	in	mm	in	mm	in	mm
1/4	6.35	1	25.40	3/4	19.05	.144	3.66
5/16	7.94	1	25.40	3/4	19.05	.144	3.66
3/8	9.53	1	25.40	3/4	19.05	.144	3.66
1/2	12.70	1-3/8	34.93	1-5/32	29.37	.187	4.76
5/8	15.88	1-3/8	34.93	1-5/32	29.37	.187	4.76
3/4	19.05	1-3/8	34.93	1-5/32	29.37	.187	4.76
7/8	22.26	1-7/8	47.63	1-9/16	39.69	.203	5.16
1	25.40	1-7/8	47.63	1-9/16	39.69	.203	5.16
1-1/4	31.80	1-7/8	47.63	1-11/16	42.86	.203	5.16

Custom Mounting Flanges available upon request. Consult Tempco with your requirements.

Cartridge Heater Lead Wire with Strain Relief Options



Type S3 Lead Wire Strain Relief

Available on HDC, HDM, and LDC cartridge heaters

Strain relief clip for leads subject to tension and stress. A "T" type strain relief is silver brazed to the sheath.

Type S4 Right-Angle Lead Wire Strain Relief

Available on HDC, HDM, and LDC cartridge heaters

Strain relief clip for leads subject to tension and stress. A "T" type strain relief is silver brazed to the sheath and bent at a 90° angle.

Cartridge Heater Option — Angled Sheath

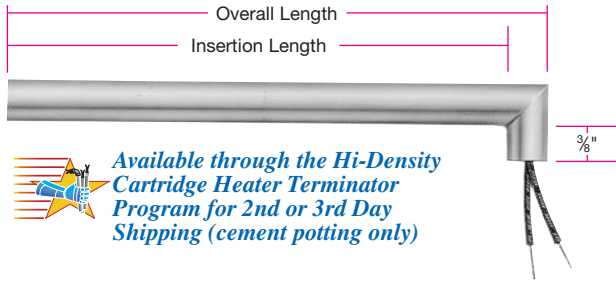

Type R3 Angled Sheath Extension

Available on HDC, HDM, and LDC cartridge heaters

The sheath extension is silver brazed to the cartridge at a 90° angle. The leads are internally connected. The standard sheath extension is 3/8" long. Specify when ordering if a longer sheath extension is required. If abrasion resistance is required, armor cable or stainless steel wire braid can be attached to the sheath extension. Available with various lead wire types and potted end seals.

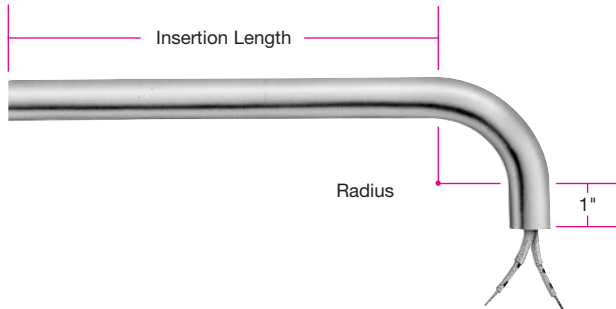

Type R4 Bent Cartridge

Available on HDC and HDM cartridge heaters

The heater sheath itself is bent to 90°. The bend is through a required cold section. The standard sheath extension past the bend is 1". Specify when ordering if a longer sheath is required.

Cartridge Dia.	in	1/4	3/8	1/2	5/8	3/4	1
	mm	6.35	9.53	12.70	15.88	19.05	25.40
Bend Radius	in	1/2	1/2	3/4	1	1-1/4	1-1/2
	mm	12.70	12.70	19.05	25.40	31.75	38.10

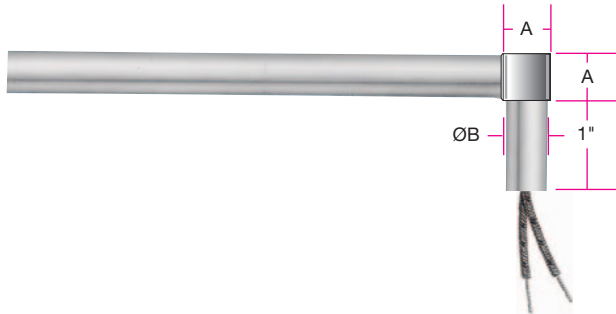

Type R5 Square Block with Tube Extension

Available on HDC, HDM, and LDC cartridge heaters

The tube extension is silver brazed or tack welded to a square S/S block. The standard tube length is 1", but different lengths can be specified. Available with various lead wire types, abrasion resistant options or potted end seals.

Heater Diameter		"A"		"B"	
in	mm	in	mm	in	mm
1/4	6.35	7/16	11.11	5/16	7.94
3/8	9.53	1/2	12.70	3/8	9.52
1/2	12.70	5/8	15.87	1/2	12.70
5/8	15.88	3/4	19.05	5/8	15.87
3/4	19.05	1	25.40	11/16	17.46

Other Sheath Options

Cartridge Heater Locating Ring

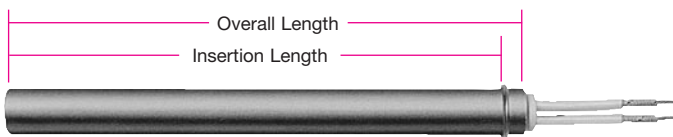

Available through the Hi-Density Cartridge Heater Terminator Program for Same or Next Day Shipping

Type LR Locating Ring

Available on HDC, HDM, and LDC cartridge heaters

A locating ring can be attached to the heater to aid in positioning the heater for the application.

The default position of the ring is 1/4" from the lead end. Specify the position of the ring when ordering.

(800) 323-6859 • Email: sales@tempco.com

Cartridge Heater Pull Strap



Available through the Hi-Density Cartridge Heater Terminator Program for Same or Next Day Shipping

Type PS Pull Strap

Available on HDC, HDM, and LDC cartridge heaters

A nickel wire rope is silver brazed to the lead end of the cartridge heater sheath to assist in removing the heater.

Cartridge Heater Terminal Box Options

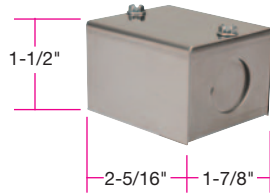
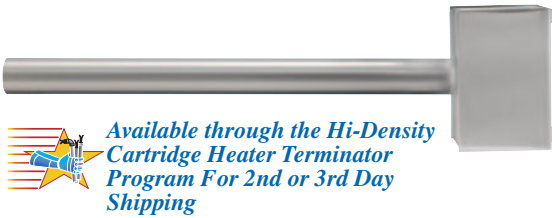

Type E1 General Purpose Terminal Box

Available on HDC, HDM, and LDC cartridge heaters

General purpose Stainless Steel NEMA 1 electrical enclosure designed to provide protection from electrical shock. The boxes have a 5/8" conduit knockout and are welded or brazed to the cartridge sheath.

➤ A termination must be specified separately.

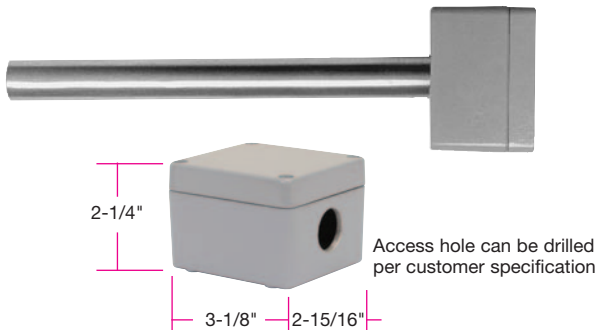

Type E2 Moisture Proof Terminal Box

Available on HDC, HDM, and LDC cartridge heaters

NEMA 4 aluminum electrical enclosures provide protection from splashing or hose directed water, external condensation and water seepage. The box is mechanically attached to the cartridge sheath.

➤ A single 5/8" access hole is standard.

➤ A termination must be specified separately.

NOTE: Potted End Seal M2C (high temperature epoxy) or M2D (low temperature epoxy) is recommended.

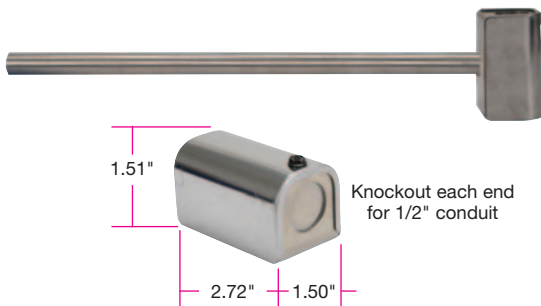

Type E4 General Purpose Terminal Box (mailbox style)

Available on HDC, HDM, and LDC cartridge heaters

General purpose Stainless Steel NEMA 1 electrical enclosure designed to provide protection from electrical shock. The box is welded or brazed to the cartridge sheath.

➤ A termination must be specified separately.

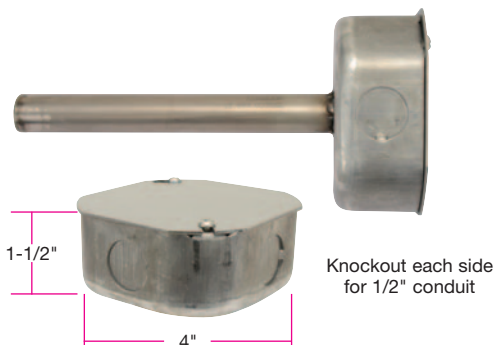

Type E5 Octagon Terminal Box

Available on HDC, HDM, and LDC cartridge heaters

General purpose steel NEMA 1 electrical enclosure designed to provide protection from electrical shock. The box is welded to the cartridge sheath.

➤ A termination must be specified separately.

Type E3 Explosion Resistant Terminal Box Options

Available on HDC and HDM cartridge heaters 1/2" diameter and larger.

NEMA 4/7 electrical enclosures provide protection from contaminants, moisture, and hazardous conditions. These housings are screwed onto a heater with a single or double ended Brass or Stainless Steel fitting.

- A threaded fitting mounting termination must be specified. See pages 2-50 and 2-51.
- Other terminal box configurations available upon request.

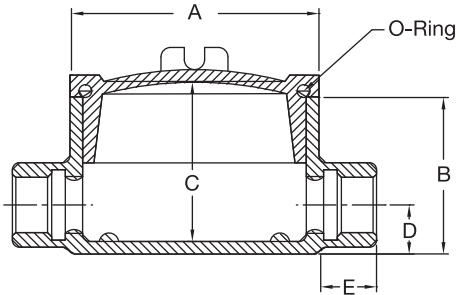

Style **E3C**



Housing E3C Dimensions

Heater Diameter(s)	Hub Size NPT	"A" (in)	"B" (in)	"C" (in)	"D" (in)	"E" (in)
1/2 & 5/8	1/2-14	2-1/2	2-1/4	2-3/16	5/8	7/8
3/4	3/4-14	2-1/2	2	2	3/4	7/8
1	1-11½	3-1/2	2-5/16	2-3/16	7/8	1

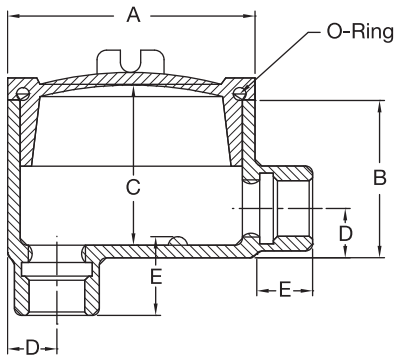

Style **E3D**



Housing E3D Dimensions

Heater Diameter(s)	Hub Size NPT	"A" (in)	"B" (in)	"C" (in)	"D" (in)	"E" (in)
1/2 & 5/8	1/2-14	2-1/2	2-1/4	2-3/16	5/8	7/8
3/4	3/4-14	2-1/2	2-1/2	2-7/16	3/4	7/8
1	1-11½	3-1/2	2-5/16	2-3/16	7/8	1

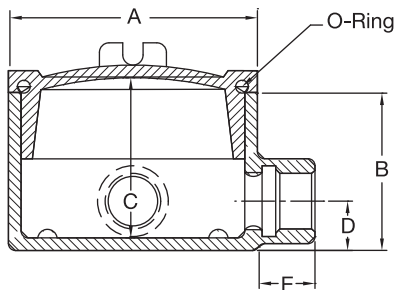

Style **E3L**



Housing E3L Dimensions

Heater Diameter(s)	Hub Size NPT	"A" (in)	"B" (in)	"C" (in)	"D" (in)	"E" (in)
1/2 & 5/8	1/2-14	2-1/2	2-1/4	2-3/16	5/8	7/8
3/4	3/4-14	2-1/2	2-1/2	2-7/16	3/4	7/8
1	1-11½	3-1/2	2-5/16	2-3/16	7/8	1



Explosion resistant terminal housings are intended to provide containment of an explosion in the enclosure only. No portion of the heater assembly outside the enclosure is covered under this NEMA rating. Abnormal use of a heater which results in excessive temperature can create hazardous conditions such as a fire. Never perform any type of service nor remove the housing cover prior to disconnecting all electrical power to the heater.

Cartridge Heaters



Lead Wire Options

Cartridge Heater Options — Lead End Connections

Type RT Ring Terminal

Type ST Spade Terminal

Type QTA 1/4" Female Straight Quick Disconnect

Type QTB 1/4" Female Right-Angle Quick Disconnect

Available on HDC, HDM and LDC cartridge heaters

Various types of crimp terminals can be attached to the heater leads to make wiring into applications quick and easy. Non-insulated and insulated with nylon (221°F/105°C) or PVC (194°F/90°C).



Note: Specify insulation type and ring size (#6, #8, or #10) when ordering. Standard is a non-insulated #10 terminal. Consult Tempco with your requirements.



Type RT



Type ST



Type QTA



Type QTB

Type P Quick Disconnect Plugs

Available on HDC, HDM, and LDC cartridge heaters

Allows for the quick and easy replacement of the heater. The plug can be attached to galvanized armor cable, stainless steel armor cable, or wire braid.

Plug Type

Description

- | | |
|----------|---|
| 1 | 2-pole/2-wire twist locking plug, 15 amp 125 volt
NEMA L1-15P (Part Number EHD-102-102) |
| 2 | 2-pole/3-wire twist locking plug, 15 amp 125 volt or
10 amp 250 volt
NEMA N/A. (Part Number EHD-102-107)
NOTE: This plug is not listed by UL, and is recommended
for replacement use only. |
| 3 | 2-pole/3-wire straight blade plug, 15 amp 125 volt
NEMA 5-15P (Part Number EHD-102-103) |
| 4 | 2-pole/3-wire twist locking plug, 15 amp 125 volt
NEMA L5-15P (Part Number EHD-102-113) |
| 5 | 2-pole/3-wire twist locking plug, 15 amp 250 volt
NEMA L6-15P (Part Number EHD-102-121) |
| 6 | 2-pole/3-wire twist locking plug, 20 amp 250 volt
NEMA L6-20P (Part Number EHD-102-122) |
| 8 | 2-pole/3-wire straight blade plug, 15 amp 250 volt
NEMA 6-15P (Part Number EHD-102-114) |
| 9 | 2-pole/3-wire twist locking plug, 20 amp 250 volt
NEMA L2-20P (Part Number EHD-102-104)
NOTE: For other types of plugs, consult Tempco or
specify the manufacturer's part number when ordering.
See page 15-15 for additional information. |

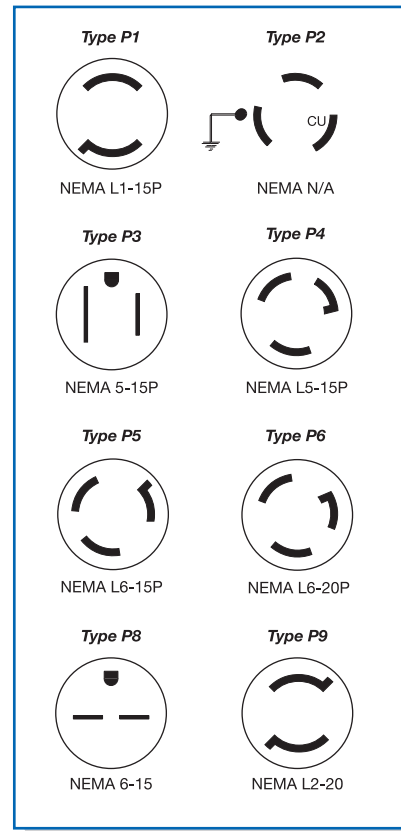

Caution! Voltage and Amperage ratings of heater and plug must match.



Available through the Hi-Density Cartridge Heater Terminator Program for Same or Next Day Shipping

Cartridge Heater Lead Wire Options

Type MIL High Temperature Lead Wire

Available on HDC, HDM and LDC cartridge heaters

When required, high temperature lead wire can be used on most cartridge heaters. The stranded wire is insulated with mica tapes and then a treated fiberglass overbraid.

- Maximum temperature rating: 450°C (842°F)

Type TL Teflon® Leads

Available on HDC and HDM cartridge heaters

- Maximum temperature rating: 200°C (392°F)

Type HA Heat Shrink Covered Armor Cables

Available on HDC, HDM and LDC cartridge heaters

- Either the galvanized or stainless steel armor cable can be covered with moisture proof heat shrink PVC tubing.

Type HTL Very High Temperature Lead Wire

Available on HDC, HDM and LDC cartridge heaters

When required, high temperature lead wire can be used on most cartridge heaters. The stranded wire is insulated with mica composite and then a treated fiberglass overbraid.

- Available wire gauge sizes: 10-18
- Maximum temperature rating: 550°C (1022°F)

Type SR Silicone Rubber Coated Fiberglass Slewing

Available on HDC, HDM and LDC cartridge heaters

For added protection, strength, and resistance to various chemicals, the lead wires can be covered with silicone rubber slewing.

SRA Silicone rubber coated fiberglass slewing on each lead separately

SRB Silicone rubber coated fiberglass slewing on both leads together

- Specify length when ordering.
- Maximum temperature rating: 200°C (392°F)

Consult Tempco with your requirements.

We welcome your inquiries.

Cartridge Heater Options — Sheath Surface and Sheath Material

Type IS Incoloy® Sheath

Available on HDC and HDM cartridge heaters.

The standard sheath material for all Hi-Density Cartridge Heaters except 1" diameter is 321 stainless steel; standard for 1" diameter is 304 stainless steel. The incoloy sheath option is available on all diameters except 1/8", 5/16", 8 mm and 20 mm.

To assist you in selecting the proper sheath material, corrosion resistant ratings and chemical properties of various heater sheath materials are given in Section 16, Engineering Data, in the back of this catalog.

Type DSM Other Special Sheath Materials

If your application requires a specific alloy sheath material other than described in Type IS above, consult Tempco with your requirements.

Type PAS Passivation

Available on HDC, HDM, and LDC cartridge heaters.

Passivating is a chemical process accomplished by dipping the heater in a solution of nitric acid. The process removes surface contamination, usually iron, so that the optimum corrosion resistance of the stainless steel is maintained.

Type OAL Special Length Tolerance

Available on HDC, HDM, and LDC cartridge heaters.

If a special length tolerance different than the standard length tolerance specified on page 2-4 is required, consult Tempco with your requirements.

Type ELP Electro-Polish

Available on HDC, HDM, and LDC cartridge heaters.

Electro-Polishing is an electro-chemical process that removes surface imperfections and contaminants, enhancing the corrosion resisting ability of the heater sheath.

Type CG Centerless Grinding

Available on HDC and HDM cartridge heaters.

For applications requiring high precision fit and tolerance, the sheath can be centerless ground.

Tolerance: ± 0.0005 inches (0.013 mm)

Specify diameter when ordering.

Type SDA End Disc Seals Silver Brazed

Type SDB End Disc Seals Heli-Arc Welded

Available on LDC cartridge heaters.

End discs on HDC and HDM cartridge heaters are heli-arc welded as standard.

The normally mechanically attached end discs on LD cartridge heaters can be silver brazed or heli-arc welded if desired.

Cartridge Heater With Built-In Internal Thermocouples

Built-in Internal Thermocouples are available on all HDC, HDM, and LDC cartridge heater diameters except for 3/16", 5/16" and 8 mm.



Notes: Type TJ4 and TK4 are not available on 1/4" and 6.5 mm diameter cartridges.

Minimum sheath length: 3" for 1/4", 3/8" and 1/2" diameter. 4" for 5/8" and 3/4" diameter.

10" leads are standard for both heater and thermocouple. Leads are internally connected. Specify longer leads.

ANSI Code	Conductor Characteristics		Temperature Range	
	Positive	Negative	°F	°C
J	Iron (Magnetic)	Constantan (Non-Magnetic)	0 to 1400	-17 to 760
K	Chromel (Non-Magnetic)	Alumel (Magnetic)	0 to 2300	-17 to 1260

For other thermocouple types consult Tempco.

Type TJ1 and TK1



Type TJ1 and TK1 Grounded at Disc End

The thermocouple junction is grounded to the sheath at the disc end and packed with MgO. The concave end disc is filled with silver solder and ground flat. When inserted into a flat end blind hole, it will provide fast responsive temperature readings. Widely used in Hot Runner mold probes.

TJ1 Type J thermocouple; **TK1** Type K thermocouple

Type TJ2 and TK2



Type TJ2 and TK2 Ungrounded at Disc End

The thermocouple junction is ungrounded, located at the end of the heater section, 1/8" behind the end disc and packed with MgO. Only provides reference temperature reading of the part being heated – slower response.

TJ2 Type J thermocouple; **TK2** Type K thermocouple

Type TJ3 and TK3



Type TJ3 and TK3 Ungrounded at Center

The thermocouple junction is ungrounded and is located in the center of the length and diameter of the cartridge heater. It provides internal temperature readings of the heater core. Generally used for research applications and is not recommended for controlling process temperatures.

TJ3 Type J thermocouple; **TK3** Type K thermocouple

Type TJ4 and TK4



Type TJ4 and TK4 Grounded at Center

The thermocouple junction is grounded to the sheath in a 1/2" unheated section located in the center of the cartridge length unless otherwise specified. It provides good temperature readings with quick response.

TJ4 Type J thermocouple; **TK4** Type K thermocouple

Type TJ5 and TK5



Type TJ5 and TK5 Grounded at Lead End

The thermocouple junction is grounded to the sheath at the lead end. A minimum of 3/8" of cold section is required. It provides good temperature readings with quick response.

TJ5 Type J thermocouple; **TK5** Type K thermocouple



Note: For a complete selection of standard Hi-Density Pennybottom™ Cartridge Heaters, with built-in Type J thermocouple for Hot Runner plastic molds, see pages 2-24 through 2-26.

Available from stock.

Cartridge Heater Options — Internal Power Variations



Type DW Distributed Wattage

Available on HDC and HDM cartridge heaters

Cartridge heaters can be designed to vary the wattage along the length of the heater. Specify number of zones and the required watts and length per zone starting from the disk end. Leads can be connected externally or internally. Picture shows a heater with Type N externally connected leads. Heaters with other terminations may require a longer cold section at the lead end.

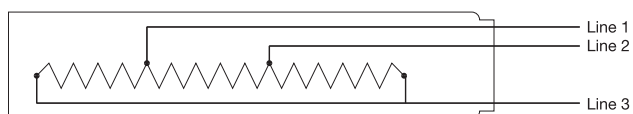

Type 3PH Three Phase

Available on HDC, HDM, and LDC cartridge heaters 1/2" diameter and larger (See page 2-4)

In order to minimize the gauge of the wiring on high wattage cartridge heaters, 3-phase elements can be designed.

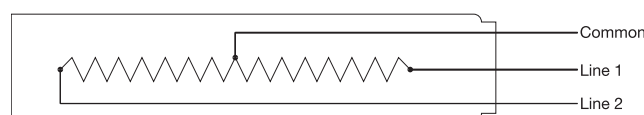

Type DV Dual Voltage

Available on HDC, HDM, and LDC cartridge heaters 3/8" diameter and larger (See page 2-4) 3/8" and 1/2" diameter heaters may require a larger diameter transition area at lead end.

Cartridge heaters can be designed using 3-wire series/parallel circuits for dual voltage applications. Whether the heater is run on the high or low voltage, the wattage will be the same.

DV1 120/240 volts **DV2** 240/480 volts

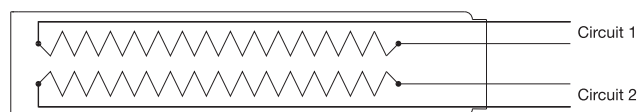

Type DWV Dual Circuits

Available on HDC, HDM, and LDC cartridge heaters 1/2" diameter and larger (See page 2-4)

Independent resistance elements can be designed in a single cartridge heater for added versatility.

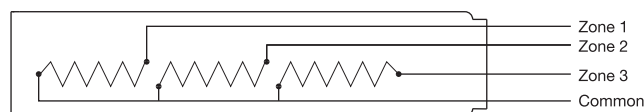

Type MHZ Multiple Heat Zones (3-Zones Maximum)

Available on HDC and HDM cartridge heaters 3/8" diameter and larger (See page 2-4) 3/8" and 1/2" diameter heaters may require a larger diameter transition area at lead end.

Multiple independently operated sections of the heater with a common wiring connection can be designed for increased flexibility.

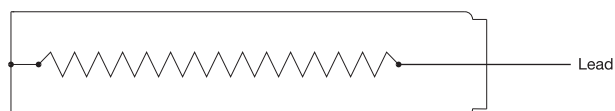

Type GJ Grounded Element Winding

Available on HDC, HDM, and LDC cartridge heaters

For DC applications where the electrical circuit is negative grounded, the cartridge heater can be designed with one side of the element winding grounded to the sheath and a single lead wire exiting the cartridge heater.

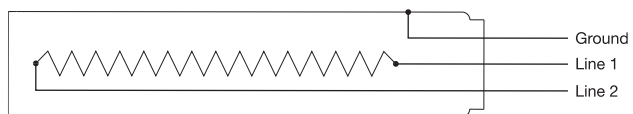

Type GL Ground Lead/Sheath

Available on HDC, HDM, and LDC cartridge heaters

For those applications requiring a separate ground lead attached to the cartridge heater sheath.

Standard ground lead wire is a 10" long insulated stranded conductor. Optional insulated and color coded leads are available.



Available through the Hi-Density Cartridge Heater Terminator Program for 2nd Day Delivery

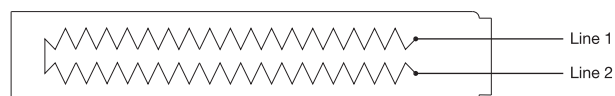

Type LLC Low Leakage Current

Available on HDC, HDM, and LDC cartridge heaters

Low leakage current construction is available for those applications such as medical products that require strict conformity to the requirements of regulatory agencies.

Options

Cartridge Heater Internal Sensor and Control Options

Type TF Thermal Fuses

Available on HDC, HDM, and LDC cartridge heaters 1/2" diameter and larger

Thermal fuses can be built into cartridge heaters to act as a high limit for the heater in applications where the temperature must be limited to avoid dangerous situations. When the trigger point is reached, the thermal fuse will open, cutting the electrical current to the cartridge heater. Once the thermal fuse opens, it cannot be reset. Many different trigger temperatures are available.

Type TS Thermostat

Available on HDC, HDM, and LDC cartridge heaters 5/8" diameter or larger

Cartridge heaters with built-in thermostats are very efficient and economical for heating and controlling temperatures. Available with NPT or special type mounting fittings, they provide a self-contained heater mainly recommended for immersion applications. They can also be used as over-temperature safety devices. The thermostats are factory preset for the trip temperature; therefore, prototyping and testing is required to determine the exact fixed setpoint. Maximum temperature—302°F (150°C). Maximum Amps—8@120 Volts.

A minimum 2-1/2" cold section is required to house the thermostat. Consult Tempco with your requirements.

Type TM Thermistor

Type RD RTD Temperature Sensors

Available on HDC, HDM, and LDC cartridge heaters

Tempco has the ability to custom design cartridge heaters with built-in temperature sensors such as thermistors and RTDs. For specific applications that have a limited or single set point range, thermistors or RTDs in conjunction with simple electronic controllers can be an economical choice.

NOTE: For thermocouples see page 2-58.

Type TS

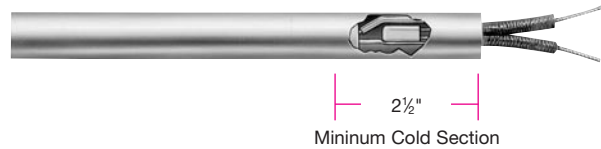

Cartridge Heater Option — Inspection Services and Test Reports

Standard Electrical Tests and Optional Test Reports

1. Resistance test — measures ohms at room temperature.
2. IR (insulation resistance) test — measures the insulation resistance to the flow of current. Standard test is done at 500VDC.
3. Hipot (high potential) test — a high voltage is applied between a product's current carrying conductors and its metallic enclosure to verify that the insulation is sufficient to protect the operator from electrical shock.
4. Leakage current test — measures the current that flows from any conductive part to ground.
5. Heaters can be serialized and test reports can be sent with each shipment if required. Contact Tempco with your requirements.

Optional Die Penetrant Test

This non-destructive testing can detect imperfections in weld joints. For critical applications, each individual heater's weld joints by end cap and fittings can be tested. Certified test reports will be sent with each shipment. Consult Tempco for details.

Optional Hydrostatic Pressure Test

Cartridge heaters with attached pipe fittings can be pressure tested to your specifications at Tempco. Our in-house testing capabilities can ensure that your products meet your exact specifications. Contact Tempco with your requirements.

LDA and HAC Forced Air In-Line Process Cartridge Heaters

TEMPCO manufactures a variety of Air Process Cartridge Heaters. They can be standard units or designed to the customer's specifications. The following diameter sizes are available: 3/8", 1/2", 5/8" and 3/4".

These diameters can be adapted with various types of fittings and made into any practical length.

See Section 11, Pages 11-74 through 11-77
for complete details

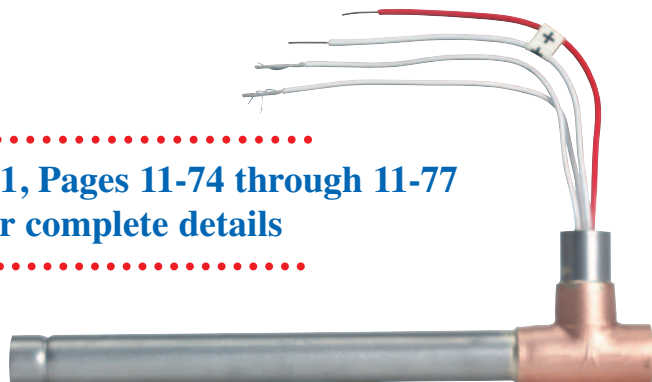

BOLT HEATERS

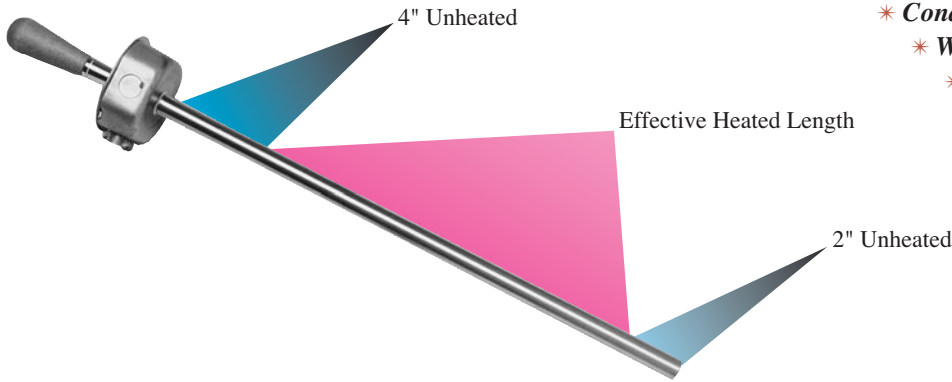

Design Features

- * *Hi-Density Construction*
- * *Conduit Box with Knockouts*
- * *Wooden Handle*
- * *High Temperature Lead Wires—250°C (482°F)*
- * *Optional SJO Cord or Post Terminals*
- * *Optional Quick Disconnect Plugs*

Typical Industries

- ✦ *Power Plants*
- ✦ *Shipyards*
- ✦ *Large Machine and Die Manufacturers*
- ✦ *Construction*
- ✦ *Boiler Manufacturers*

Typical Applications

- ✦ *Large Compressors*
- ✦ *Turbines*
- ✦ *Die Blocks*
- ✦ *Large Cylinders*
- ✦ *Engine Heads*
- ✦ *Pressure Vessels*

TEMPCO Bolt Heaters are used as an aid to tighten large bolts in heavy machinery and equipment. Heaters are sized for easy insertion into a hollow bolt. The rapid heating of the bolt expands it, allowing further tightening of the nut. The heater is then de-energized and removed. As the bolt cools, its contraction back to original size provides a tight fit.

Tempco Bolt Heaters are constructed with one of the industry's most efficient and highest quality heating elements—Tempco Hi-Density (swaged) Cartridge Heaters; with close tolerance fits, watt densities of 100 watts per square inch are obtainable—65% higher than standard cartridge or tubular heating elements can deliver. The higher wattage on Hi-Density Bolt Heaters means quicker heat-up time and minimum heat loss to the area surrounding the bolt.

Bolt Heaters Standard Specifications and Tolerances

DIMENSIONAL SPECIFICATIONS

Actual Diameter (in)	.438	.496	.553	.580	.621	.660	.710	.745	.813	.993
Actual Diameter (mm)	11.1	12.6	14.0	14.7	15.8	16.8	18.0	18.9	20.7	25.2

Diameter Tolerance: $\pm .005$ (.127 mm)

Length Tolerance: $\pm 2\%$ of sheath length

Camber Tolerance: .020" (0.38 mm) per foot of length

ELECTRICAL SPECIFICATIONS

Diameter (in)	.438	.496	.553	.580	.621	.660	.710	.745	.813	.993
Maximum Voltage	240	240	240	240	480	480	480	480	480	480
Maximum Amperage	6.7	10.5	10.5	23	25	25	25	25	25	25

If tighter tolerances are required, consult Tempco.

CONTINUED

Standard (Non-Stock) Bolt Heaters

Continued from previous page...

Heater Diameter in (mm)	Inserted Length		Heated Length		Watts	Watt Density		Part Number 240V
	in	mm	in	mm		W/in ²	W/cm ²	
.438 (11.1)	18	457	12	305	1000	60.6	9.4	HDB00001
	24	610	18	457	1500	60.6	9.4	HDB00002
.496 (12.6)	18	457	12	305	1900	101.6	15.8	HDB00003
	24	610	18	457	2300	82.0	12.7	HDB00004
	30	762	24	610	2300	61.5	9.5	HDB00005
	36	914	30	762	2300	49.2	7.6	HDB00006
.553 (14.0)	18	457	12	305	1200	57.6	8.9	HDB00007
	24	610	18	457	1700	54.4	8.4	HDB00008
	30	762	24	610	2500	60.0	9.3	HDB00009
	36	914	30	762	3200	61.4	9.5	HDB00010
.580 (14.7)	18	457	12	305	2200	100.6	15.6	HDB00011
	24	610	18	457	3300	100.6	15.6	HDB00012
	30	762	24	610	4350	99.5	15.4	HDB00013
	36	914	30	762	5450	99.7	15.5	HDB00014
.621 (15.8)	18	457	12	305	2350	100.4	15.6	HDB00015
	24	610	18	457	3500	99.7	15.4	HDB00016
	30	762	24	610	4700	100.4	15.6	HDB00017
	36	914	30	762	5500	94.0	14.6	HDB00018
.660 (16.8)	18	457	12	305	1200	48.2	7.5	HDB00019
	24	610	18	457	1700	45.5	7.1	HDB00020
	30	762	24	610	2300	46.2	7.2	HDB00021
	36	914	30	762	2800	45.0	7.0	HDB00022
.710 (18.0)	18	457	12	305	2700	100.9	15.6	HDB00023
	24	610	18	457	4000	99.7	15.4	HDB00024
	30	762	24	610	5350	100.0	15.5	HDB00025
	36	914	30	762	5500	82.2	12.7	HDB00026
.745 (18.9)	18	457	12	305	2800	99.7	15.5	HDB00027
	24	610	18	457	4200	99.7	15.5	HDB00028
	30	762	24	610	5500	97.9	15.2	HDB00029
	36	914	30	762	5500	78.3	12.1	HDB00030
.813 (20.7)	18	457	12	305	1800	58.7	9.1	HDB00031
	24	610	18	457	2500	54.4	8.4	HDB00032
	30	762	24	610	3500	57.1	8.6	HDB00033
	36	914	30	762	4200	54.8	8.5	HDB00034
.993 (25.2)	18	457	12	305	3750	100.2	15.5	HDB00035
	24	610	18	457	5500	97.9	15.2	HDB00036
	30	762	24	610	5500	73.5	11.4	HDB00037
	36	914	30	762	5500	58.8	9.1	HDB00038



Note: Part Numbers shown are for heaters with standard 10" long leads and a conduit box with wooden handle.

Hi-Density Bolt Heaters are made-to-order only.

Ordering Information

Catalog Heaters

Order by Catalog Part Number from the Standard Sizes and Ratings List.

Note that Part Numbers shown are for heaters with 10" long, 428°F (250°C) stranded flexible lead wires inside the conduit box.

Standard lead time is 3 weeks.

Custom Engineered/Manufactured Heaters

Because an electric heater can be very application specific, for sizes and ratings not listed, **TEMPCO** will design and manufacture a Bolt Heater to meet your requirements. **Standard lead time is 3 weeks.**

Please Specify the following:

- | | |
|--|--|
| <input type="checkbox"/> Diameter | <input type="checkbox"/> Voltage |
| <input type="checkbox"/> Insertion Length | <input type="checkbox"/> Lead Length or Post Terminals |
| <input type="checkbox"/> Cold Section (top and bottom) | <input type="checkbox"/> Optional Cord or Plug |
| <input type="checkbox"/> Wattage | <input type="checkbox"/> Special Features |

WARNING: Cancer and Reproductive Harm - www.P65Warnings.ca.gov.

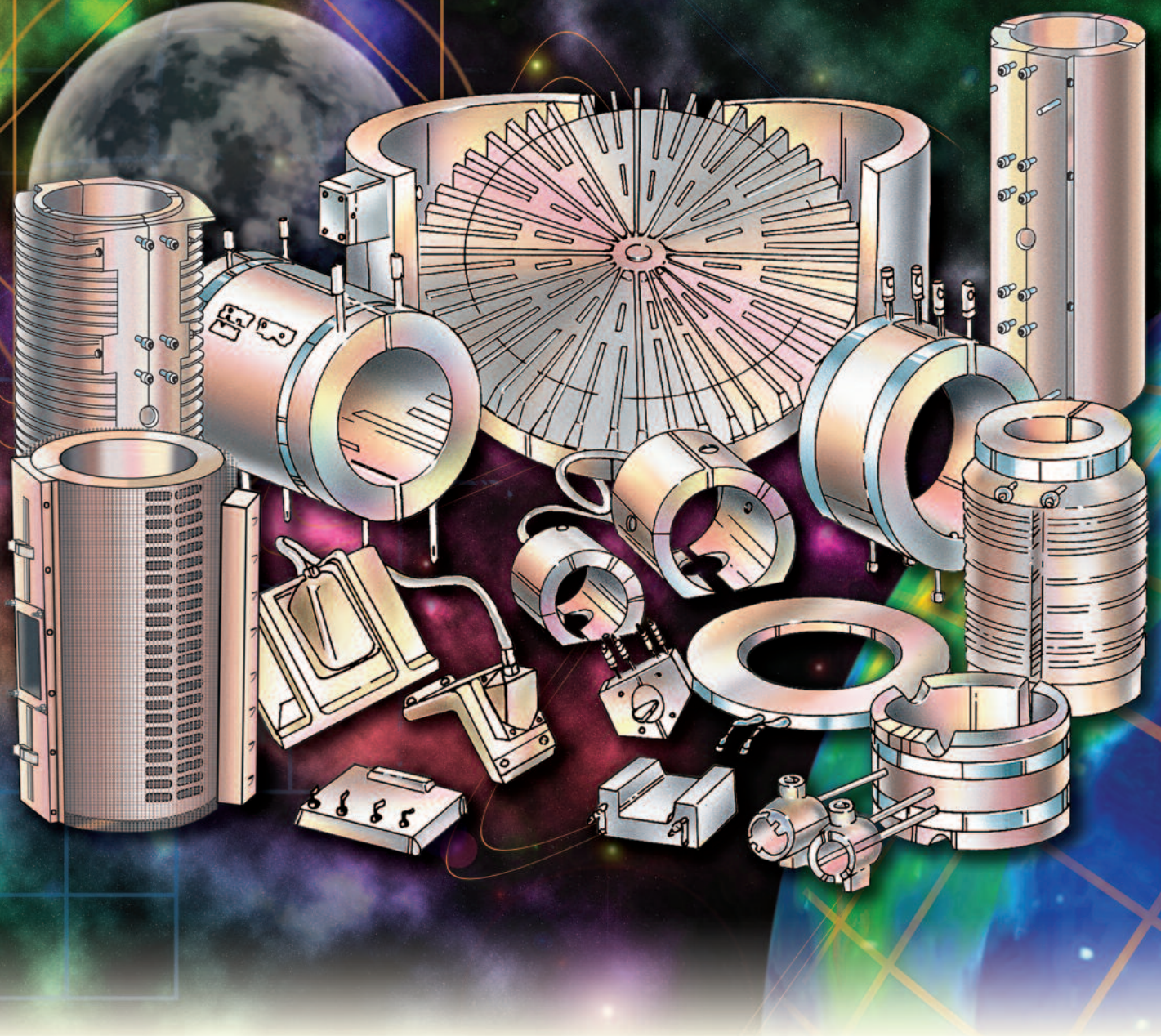

Table Of Contents

Pictorial Index	A-8	Cast-In Heaters for Plastics Processing ...	3-24
Introduction & Design Specifications	3-2	Extruder Heating and Air	
Cast-In Thermal Components for		Cooling Shroud Systems	3-26
Diversified Industries.....	3-6	Finned Air-Cooled Cast-In Heaters	3-44
Transfer/Feed Pipes	3-9	Liquid-Cooled Cast-In Heaters.....	3-48
Semiconductor Manufacturing.....	3-10	“L” Shaped Cast-In Heaters.....	3-64
Food Service Industry	3-11	Cast-In Ring Heaters	3-68
Circulation Heaters	3-12	Cross Head Die Heaters.....	3-69
Large Thermo-Platens	3-18	Cast-In Platen Die Heaters	3-70
Liquid Cool.....	3-20	Special Cast-In Heater Shapes	3-72
		Installation Recommendations.....	3-74

3

section

Cast-In Heaters



Delivering Cutting Edge Solutions with Highly Customized/Engineered Cast-In Thermal Components

Developing Solutions Through Product Innovation

Tempco is a name synonymous with state-of-the-art technology and a strong commitment to providing practical, cost effective, quality thermal component solutions. We are a widely recognized industry-leading authority in the design, engineering and manufacturing of cast-in heaters and cast-in thermo cooling components.

Tempco's expertise and flexible manufacturing capabilities allow cast-in thermal components to be designed in virtually any imaginable size and shape, including complex and challenging geometries. Casting alloys used are aluminum, brass, and bronze.

Supporting A Diversified Segment of Industries

Tempco has a proven track record of successfully assisting our customers in solving or improving complex and challenging applications with cast-in thermal component technology, whether for heating or cooling functions. We consistently deliver on our commitment to exceed our customers' expectations in a diverse segment of industries from Original Equipment Manufacturers (OEMs), to Research and Development, Life Science, and Maintenance (MRO) Applications.

***Consult Us with Your Requirements
We Welcome Your Inquiries***

Supporting Diversified & Demanding Industrial, Life Science, Commercial & Scientific Applications

Vertically Integrated Manufacturing Capabilities

Tempco is a company uniquely qualified and committed to taking full ownership and responsibility of your Cast-In thermal component challenges. Consult Tempco at the early stages of your application requirements; we can provide you with the ultimate solution that will achieve cost savings and reliability with both functional and aesthetic quality.

Tempco's in-house manufacturing capabilities to produce Cast-In Thermal Components include:

- ✦ Custom designing and engineering utilizing 3-D and CAD/CAM solid modeling technology
- ✦ Tubular and Cable Heating Element manufacturing
- ✦ Full service foundry facility processing Aluminum, Brass, and Bronze Alloys
- ✦ Foundry tooling fabrication — Steel or Cast Iron Permanent Molds, Wood or Plastic Patterns
- ✦ Machining — Full service State-of-the-Art CNC machine shop capabilities including Coordinate Measuring Machine
- ✦ Lab services — computerized infrared heating profiles, life cycle testing, X-ray examination, 3-D solidification modeling

Experience our Passion for Excellence in the Design & Manufacturing of Cast-In Thermal Components

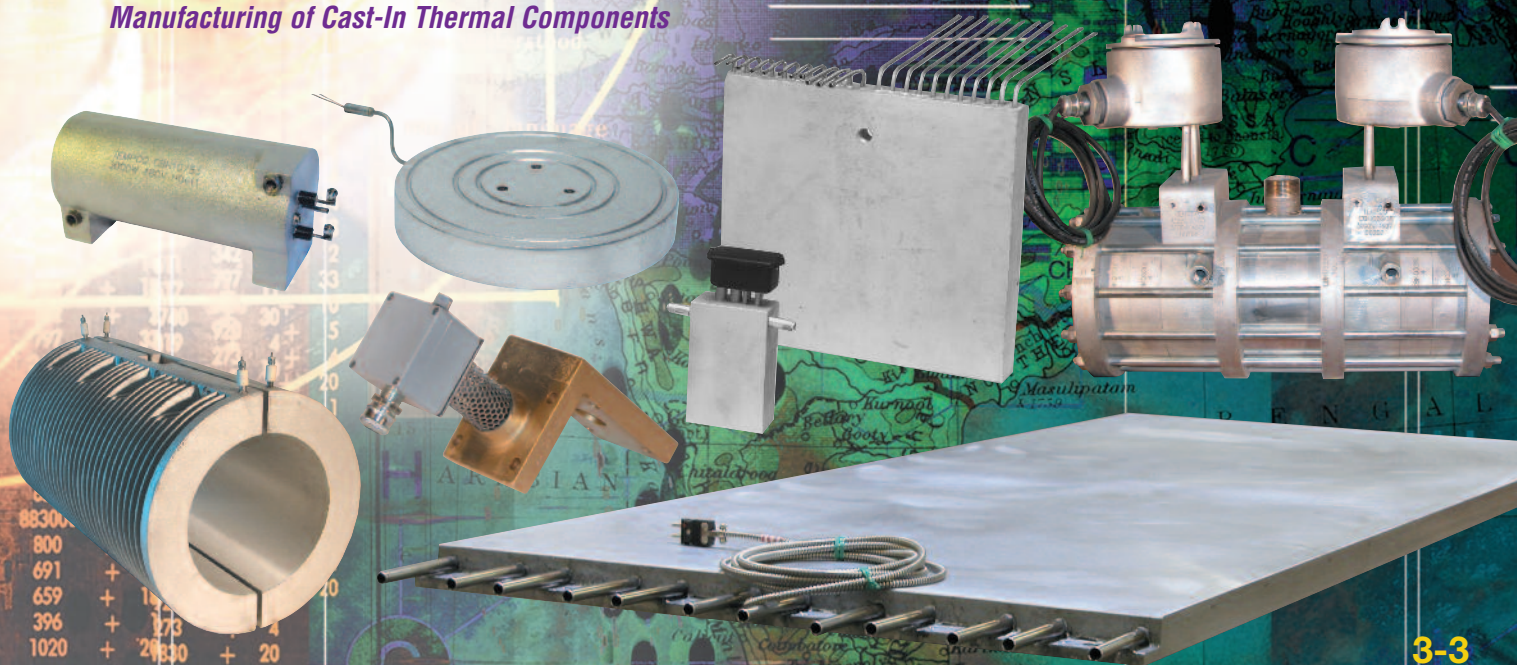

One Source Providing Extensive Engineering/Manufacturing Capabilities



Casting Process: Low Pressure

Used for large volume quantities. Specifically suited for intricate and challenging geometric shapes, producing quality castings with consistent dimensional accuracy and superior surface finish.

Alloy: Aluminum (only)

Tooling: Requires a Steel or Cast Iron Permanent Mold

Machining: Minimum to no machining

Weight Capacity: Up to 150 pounds depending on shape

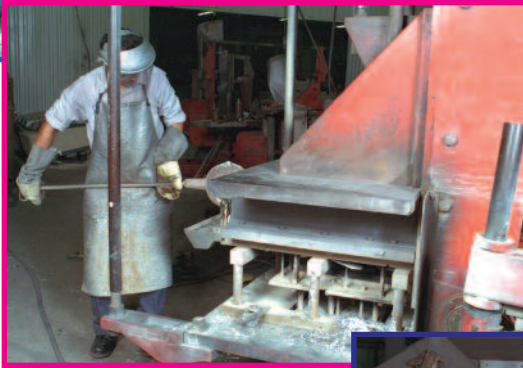

Casting Process: Tilt-Pour Gravity Feed

Used extensively for medium to high volume quantities. Will accommodate simple to some irregular shape castings, producing good dimensional accuracy and surface finish.

Alloy: Aluminum (only)

Tooling: Requires a Steel or Cast Iron Permanent Mold

Machining: Moderate to Extensive

Weight Capacity: Up to 150 pounds depending on shape

Casting Process: No-Bake Sand Molds

Used for lower volume quantities, prototypes, very large irregular shapes and thermal platens.

Alloys: Aluminum, Brass, Bronze and Iron

Tooling: Requires a Wood or Plastic Pattern

Machining: Extensive

Weight Capacity: Up to 600 pounds



Melting Capabilities

- Electric Reverb and Induction furnaces are used to minimize gas inclusion into the molten metal, thereby producing a denser, higher quality casting.

CNC Machining

There are certain dimensional and/or finish tolerances or geometry that cannot be produced as cast and must be machined. Tempco offers a full service state-of-the-art machine shop featuring various types of CNC machine tools to perform all of the precision machining required—from simple to complex contour geometrics, including turning and/or boring, with repeatable accuracy from one machined casting to the next. Machinists also build and maintain permanent mold tooling for the low pressure and tilt-pour gravity feed casting processes.



CMM Inspection

Coordinate Measuring Machine provides precise measurement of complex parts in process or at final inspection.



No one can do it better than Tempco – LET US PROVE IT!

Pattern Shop

Tempco has an in-house Pattern Shop to build and maintain the wood or plastic patterns required to produce castings with no-bake sand molds.



Experience Our Value-Added Services that are Second to None

Casting Alloys

Casting Alloy	Aluminum	Copper	Silicone	Zinc	Lead	Maximum Iron	Tin	Other
Aluminum 319	85.8 - 91.58%	3.0 - 4.0%	5.50 - 6.50%	≤ 1.0%	—	≤ 1.0%	—	≤ 1.7%
Aluminum 356	90.1 - 93.3 %	≤ 0.25%	6.50 - 7.50%	≤ 0.35%	—	≤ 0.60%	—	≤ 1.125%
Bronze	9.0 - 11.0%	≥ 86.0%	—	—	—	0.80 - 1.50%	—	≤ 1%
Yellow Brass	≤ 0.55%	58.0 - 64.0%	≤ 0.05%	32.0 - 40.0%	0.80 - 1.50%	≤ 0.70%	0.50 - 1.50%	≤ 1%

Material Properties

Material	Classification	Max. Surface Temperature °F (°C)	Density (lb/in ³)	Coefficient of Linear Thermal Expansion (in/in/°F × 10 ⁻⁶)	Specific Heat Capacity (BTU/lb-°F)	Thermal Conductivity (BTU-in/hr-ft ² -°F)	Melting Point (°F)
Aluminum 319	Aluminum 319.0	700 (371)	0.101	12.7 @ 68° - 572°F	0.23	754	960 - 1120
Aluminum 356	Aluminum 356.0	750 (399)	0.0968	12.9 @ 68° - 572°F	0.23	1160	1030 - 1140
Bronze	UNS C95300	1350 (732)	0.272	9 @ 68° - 572°F	0.0896	437	1900 - 1913
Yellow Brass	UNS C85700	1200 (649)	0.304	12.2 @ 68° - 500°F	0.0899	582	1660 - 1690

Linear Thermal Expansion Formula: $\Delta L = L_i \times \alpha \times (T_f - T_i) \times 10^{-6}$

ΔL = Change in Length

L_i = Initial Length

T_f = Final Temperature

α = Coefficient of Linear Thermal Expansion

T_i = Initial Temperature

Minimum Casting Thickness vs. Heating Element and/or Cooling Tube Diameters

Casting Thickness	Maximum Available Element Diameter Heat Only	Maximum Available Cooling Tube Diameter Cool Only	Maximum Element and Cooling Tube Combination Heat and Cool
5/8" (15.9 mm)	.260	1/4	—
3/4" (19.1 mm)	.375	3/8	—
1" (25.4 mm)	.430	1/2	—
1-1/4" (31.8 mm)	.430	1/2	.260 and 3/8
1-3/8" (34.9 mm)	.430	1/2	.315 and 1/2
1-1/2" (38.1 mm)	.430	1/2	.430 and 1/2
1-5/8" (41.3 mm)	.430	1/2	.430 and 1/2
1-3/4" (44.5 mm)	.430	1/2	.430 and 1/2
Finned Casting			
3/4" (19.1 mm)	.375	—	—
7/8" (22.2 mm)	.430	—	—
1" (25.4 mm)	.430	—	—
1-3/4" (44.5 mm)	.430	—	—

Casting Size & Weight Limitations

	Cylindrical	Platen
Minimum Inside Diameter:	1" (25.4 mm)	—
Maximum Inside Diameter:	48" (1219 mm)	—
Minimum Width:	—	1-1/2" (38.1 mm)
Maximum Width:	—	60" (1524 mm)
Minimum Length:	1-3/4" (44.5 mm)	4" (102 mm)
Maximum Length:	40" (1016 mm)	72" (1829 mm)
Finish:	125 RMS Standard or to customer spec.	
Gap (two-piece cylindrical cast-in band heaters):	1/4" (6.4 mm) top and bottom or to customer specification	
Maximum Weight:	Aluminum— 600 pounds Bronze & Brass— 300 pounds	

NOTES: Cylindrical heaters are made with two half-round heaters. Cast-In thermal components can be made in any practical size, weight and geometric shape.

Heating Element Electrical Specifications

Tubular Heater Diameter	.260"	.315"	.375"	.430"
Maximum Volts	240	277	480	600
Maximum Amps Per Element	15	30	40	40
Maximum Watt Density:	Aluminum Alloy—35 W/in ² on the element Bronze or Brass—45 W/in ² on the element			
Resistance Tolerance:	+10%, -5%			
Wattage Tolerance:	+5%, -10%			
Three Phase available depending on casting size. Ground Studs can be added to most cast-ins.				



Note: Tempco-Pak mineral insulated cable heaters can be used in place of tubular heating elements to fit physical constraints not possible with conventional heating elements. See catalog Section 5 for more details.

Cooling Tube Materials for Castings with Liquid Cooling

Tube Material	Tube OD and Wall Thickness
Stainless Steel (Standard)	1/4" O.D. × .028 wall
Stainless Steel (Standard)	3/8" O.D. × .035 wall
Stainless Steel (Standard)	1/2" O.D. × .049 wall
Stainless Steel (Optional)	5/8" O.D. × .049 wall
Incoloy® 840 (Optional)	1/2" O.D. × .049 wall
Tubing with heavier wall thickness is available upon request.	

Options for Cast-In Thermal Components

Casting Surface Treatments

Special surface finishes are required in some applications:

- Electroless Nickel Plating
- Anodizing
- Teflon®
- Hard-Coat Anodizing
- Magnaplate

Lab Services

- Computerized Infrared Heating Profiles
- Life Cycle Testing
- X-Rays to confirm heating element location and casting density
- Heating Ramp Rate Testing

Agency  US Approvals

Cast-In Heater Elements are UL recognized under UL File Number E90771.

If you require UL Agency Approval, please specify when ordering.

Cast-In Heaters – Complex Geometrics for Diversified Industries

Delivering Cutting-Edge Engineered Cast-In Thermal Component Solutions

Today's fast-paced and high-tech industries demand products that are high quality, unique, reliable, and diverse. Tempco is passionate about meeting those expectations and putting our customers' needs first by providing quality service and products with superior capabilities. Tempco specializes in engineering and manufacturing customized cast-in thermal component solutions to service and support virtually all major industries. The following pages illustrate a sampling of cast-in thermal components we have produced for original equipment manufacturers (OEMs) and maintenance (MRO) applications that enjoy the advantages and benefits our products offer.

High Performance Cast-In Thermal Components are not Just a Challenge – They Are Our Bread & Butter. Please Consult Us with Your Requirements. We Welcome Your Inquiries.



Cast Iron Manifold Heater for Aluminum Low Pressure Casting Machine

Aluminum Cast-In Heater for Plastic Extrusion

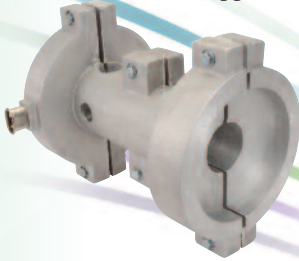

Rectangular Manifold Cast-In Heater



Aluminum Cast-In Heater Used in the Carpet Mill Industry

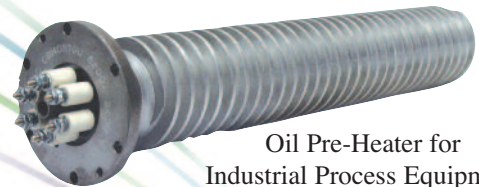

Oil Pre-Heater for Industrial Process Equipment



Barrel Adapter for Polymer Extruder Equipment



Heating Elements & Aluminum Cast Over Steel Transfer Feed Pipe



Autoclave Aluminum Cast-In Heater Electroless Nickel-Plated for Sterilizing Dental Instruments

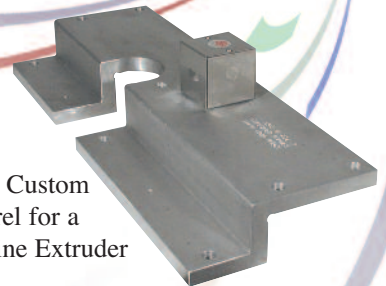

Heater used on a Custom Rectangular Barrel for a Monofilament Line Extruder

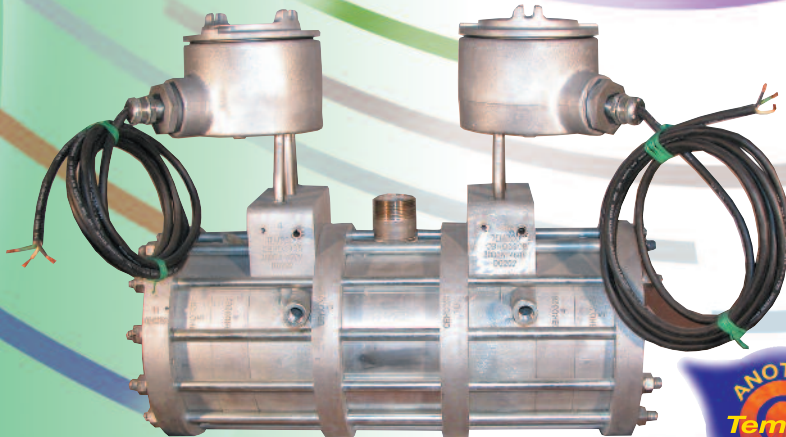

System for Pre-Heating and Mixing Chemicals for Sand Cores

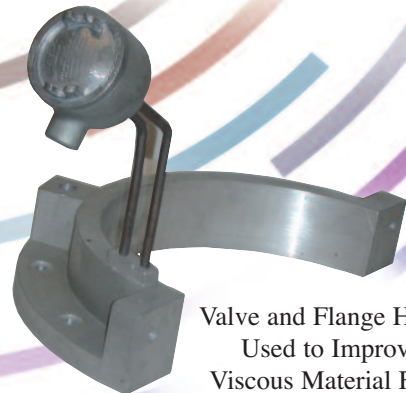

Valve and Flange Heater Used to Improve Viscous Material Flow



Cast-In Heaters – Complex Geometrics for Diversified Industries



Heating & Cooling Cylinder used in Lab Testing Equipment

Cast-In Heater Used to Decrease Viscosity in Glue Processing

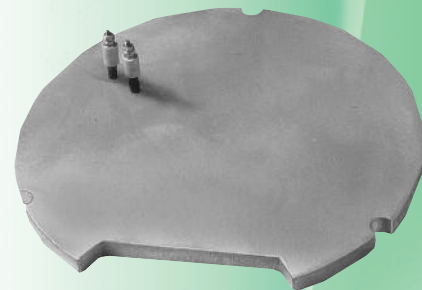

Waste Treatment Sanitation Equipment Heater

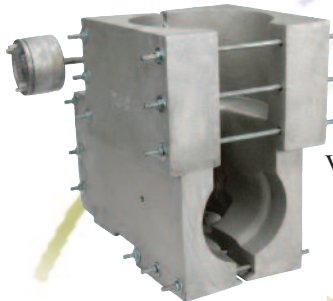

Manifold Valve Assembly



Bronze Cast-In Heater for Package Sealing Machine



Used as a Resistor for Thermal Dynamic Braking of Large Electric Motors



Cast-In Platen used for Heating a Custom Rectangular Extruder Barrel

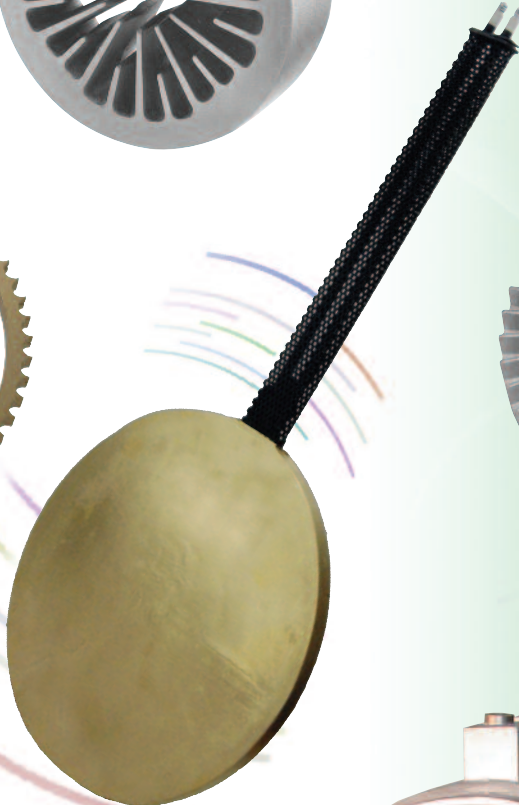
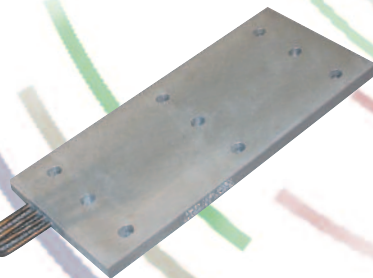

Bronze Cast-In Heater for Pre-Heating Salt Baths

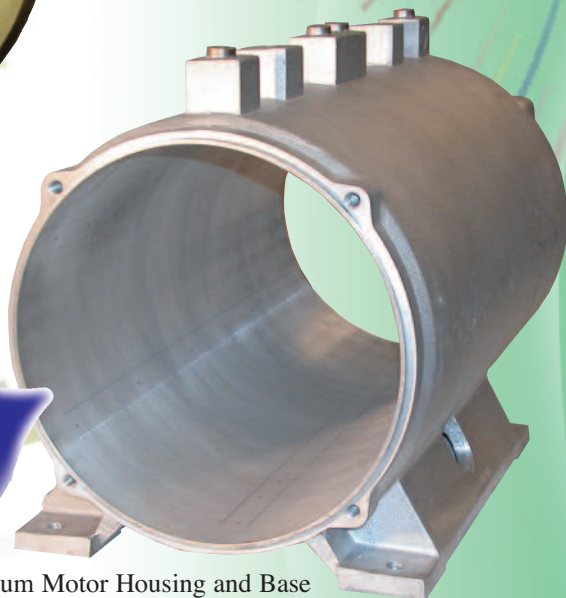

Cast Aluminum Motor Housing and Base with Integral Liquid Cool Capabilities used for Medium to Large Horsepower Electric Motors
Can be made for any size motor.

Developed and Patented by Tempco
U.S. Patents: # 622289 & #5939808

In-Line System for Pre-Heating Water to Induce Humidity in Baking Ovens



Bronze Cast-In Heater for a Laminating Press

CONTINUED →

Cast-In Heaters – Complex Geometrics for Diversified Industries

Continued from previous page...



Used in the Packaging Industry for Adhering Tax Stamps to Cigarette Packs

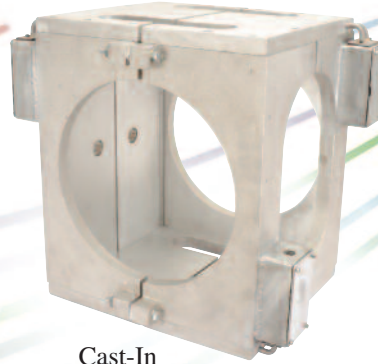

Cast-In Heater for Melt Pump

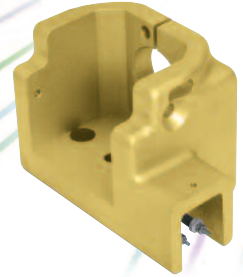

Brass Casting Used in Industrial Processing Machinery



Used in a Thermoforming Mold



Bronze Electroless Nickel-Plated Cast-In Heater Used in Equipment that Tests Nuclear Hazardous Waste

Used as Part of a Feed Nozzle in a Candy Processing Machine



Bronze Cast-In heater used to maintain Hydraulic Oil Temperature

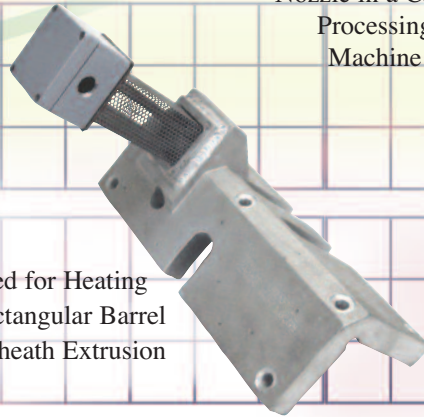

Used for Heating a Rectangular Barrel for Sheath Extrusion

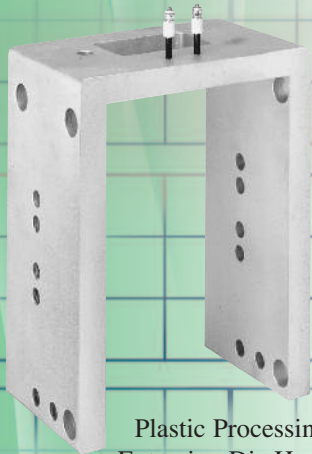

Plastic Processing Extrusion Die Heater

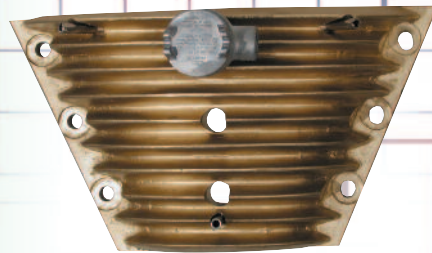

Bronze Cast-In Heater Used in Helicone Mixture to Heat High Viscosity Material

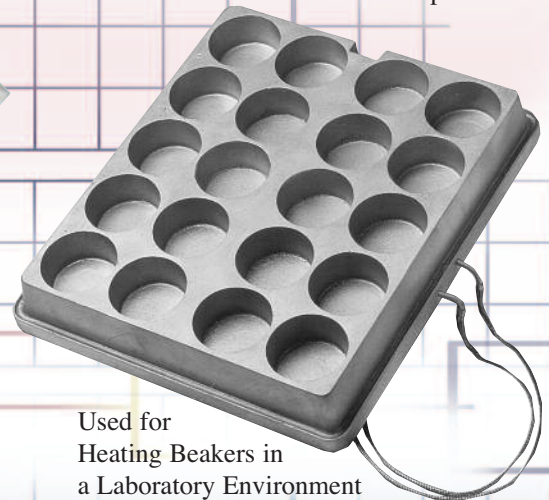

Used for Heating Beakers in a Laboratory Environment

Additional Applications Where Tempco Cast-In Heaters Are Used

- Chemical Processing
- Extrusion Die Heaters
- Food Service Equipment
- Glue Pots
- Heat Sealing Equipment
- Heat Treating Equipment
- Hot Melt Dispensing Equipment
- Hot Stamping Machinery
- Laboratory Equipment
- Laminating Equipment
- Life Science Equipment
- Packaging Machinery
- Plastics Machinery
- Research and Development
- Silk-Screening Equipment
- Solvent Reclaim Equipment
- Steam Cleaning Equipment
- Textile Manufacturing
- Vacuum Forming



Note: The cast-in thermal components shown on pages 3-6 through 3-14 are merely a sampling of our capabilities.

Let the endless possibilities spark your imagination!

Put our knowledge and experience to work for you.

Challenge us!
You will be glad you did.

We Welcome Your Inquiries

Cast-In Heaters for Transfer/Feed Pipes

Tempco offers the perfect solution to heat Complex Transfer/Feed Pipes

Transfer pipes used in large-scale extrusion lines are difficult to heat because of their irregular geometry. They are not machined cylinders so proper contact and heat transfer are difficult to achieve.

Consequently, a special Cast-In Heater must be engineered for each pipe to accommodate its individual characteristics. Typically, this entails the customer sending the pipe to Tempco and our Engineering staff designing a Cast-In Heater System that will optimally fit the pipe. The quality of the process will be improved because hot spots and/or unevenly heated surfaces can be eliminated. In some cases, we cast the heater directly onto the pipe.

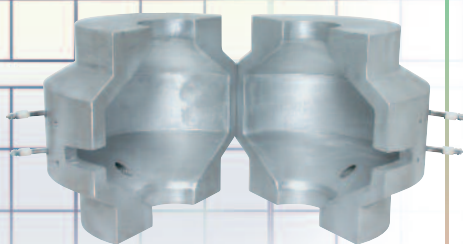
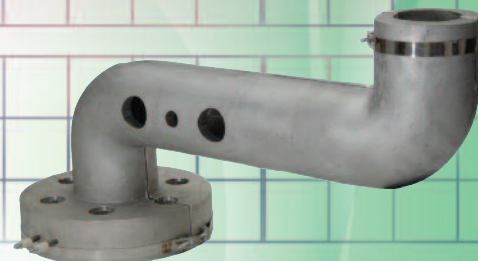
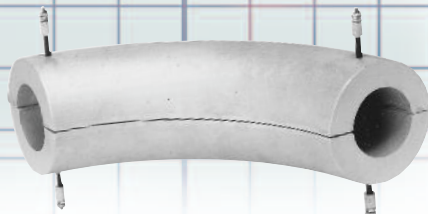
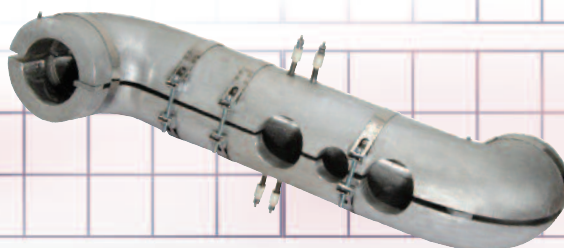
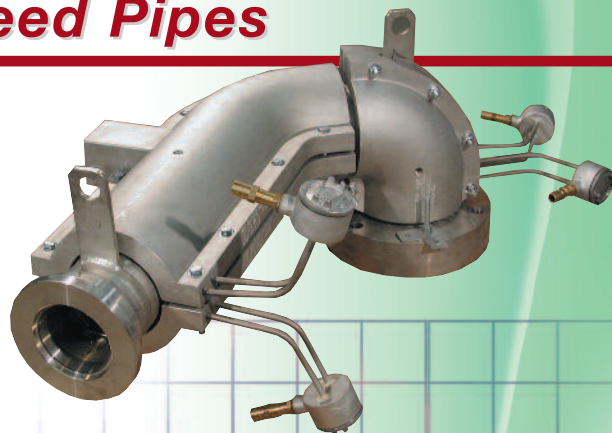

*Let Tempco's Creative Team of
Professionals Tackle Your Next Cast-In
Thermal Component Project.
We Have the Technology,
Infrastructure & Commitment to
Exceed Our Customers' Expectations.*

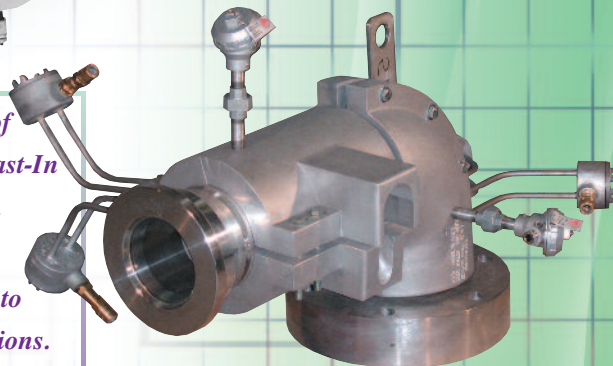

Special Cast-In Process for Unusual and Complex Applications



In the event that a cast-in heater cannot be made the conventional way for assembly into a machine part, Tempco has the expertise to directly attach a tubular heating element or a tube for cooling purposes to a customer supplied part.

By making a wood pattern with the required shape we can create a sand mold to encapsulate the entire assembly and pour the molten aluminum or bronze over the part.

The sample depicted in this picture represents the typical process. In this case, a tubular heating element is attached to a steel roller and is then placed in a sand mold prior to casting. After casting, the roller OD is machined per customer specifications — in addition, the aluminum roller will be vulcanized with rubber. The finished heated roller will be used in a laminating web press.



Cast-In Heaters for Semiconductor Manufacturing

Cast-In Heaters for the Semiconductor Processing Industry

Tempco has been at the forefront of the industry, addressing the challenges of stringent operating parameters and high quality requirements faced by original equipment manufacturers specializing in the semiconductor, wave solder and reflow surface mount processes.

By employing state-of-the-art technologies and by utilizing our acquired knowledge as a company, we have met the challenges by offering and delivering excellence in the design, engineering and manufacturing of a complete selection of innovative, reliable and high quality cast-in aluminum thermal component products.

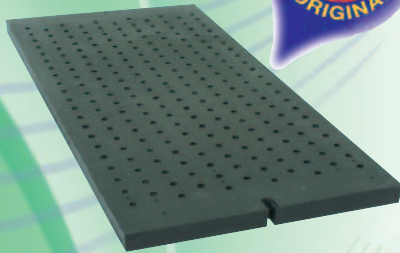
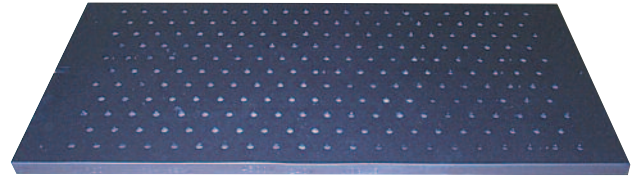

Cast-In Thermal Platens for Wave Solder & Reflow Surface Mount Equipment

Tempco's highly engineered platens are capable of maintaining a temperature gradient of 5°F (2.77°C) across the entire working surface of the heater platen at the process operating temperature. The innovative design of this cast-in thermal platen incorporates the dual functions of being both a radiant and a convection heat source.

Cast-In Heaters for Wafer Processing

Tempco offers a complete selection of highly customized semi-conductor process heaters which include *Pedestal Heaters, Pedestal Heaters with Integrated Cooling Capabilities, Bake Platen Heaters, High-Temperature Platen Heaters with Interference Press Fit Tubular or Cable Heating Elements*. For this type of platen heater construction the available base alloys are *Aluminum, Brass or Bronze*.

Our metallurgical knowledge and foundry expertise are the catalyst for producing cast-in heaters with the precise heat profiles and temperature gradient required for the process. Tempco's state-of-the-art CNC machining capabilities will ensure that the working surface requirements of the part are precisely machined to customer requirements, including extremely flat surfaces, to within 0.0005 in (0.0127 mm) for optimizing the performance of the application.

In order to satisfy the stringent requirements of the industry, these products are manufactured under rigid quality control standards. Specific attention is directed to the heating element design and the casting processes.

Design Features & Options

- * *Casting Maximum Surface Temperature*
Aluminum Alloy 319: 700°F (371°C)
Aluminum Alloy 356: 750°F (399°C)
- * *Interference Press Fit Construction – maximum surface temperature depends on base alloy used*
- * *Surface Finish – Hard-Coat Anodized*
- * *Built-in Temperature Sensors*
- * *Selection of heating element and cooling tube terminations*



Note: Cast-In heaters for semiconductor processing are made to customer specifications. For technical assistance, engineering data and available options

please refer to pages 3-4 and 3-5. When ordering, please provide detailed design drawings including dimensions, critical tolerances, watts, volts, and any other features or special requirements.

CHX-100 Series Circulation Heater

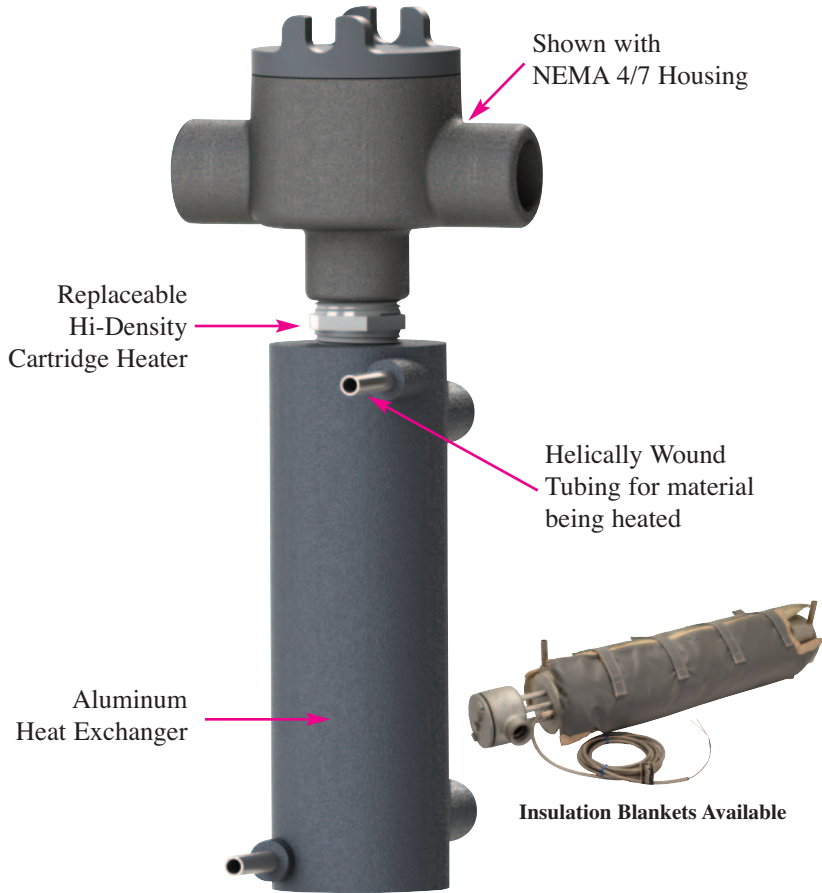

Standard Design Features

- * Seamless 316 SS Tubing for fluid flow
- * Replaceable 5/8" diameter Hi-Density Cartridge Heater
- * Cast Aluminum heat exchanger body
- * Operating pressure up to 3000 PSI
- * Operating temperature up to 350°F (177°C)
- * NEMA 4/7 enclosure with standoff standard

Optional Design Features

- * Process Thermocouple
- * Overtemperature Thermocouple
- * High Limit Thermostat

Typical Applications

- ✦ Solvent heating (MEK, NMP, ACT, EKC, others)
- ✦ Heating of Air, CO₂, Nitrogen and similar gases
- ✦ Heating of non-flammable gases
- ✦ De-ionized water heating
- ✦ Steam generation
- ✦ Glycol heating
- ✦ Heating ink in printing
- ✦ Diesel and Fuel heating
- ✦ Packaging sterilization
- ✦ Analytical instrumentation
- ✦ Food and beverage heating
- ✦ Coating and Paint heating

Construction

The CHX-100 circulation heater is a compact lightweight unit used for heating gases or liquids. The material being heated is pumped through the coiled seamless 316 SS tubing which has been cast into an aluminum body that acts as the heat exchanger. A replaceable Hi-Density cartridge set into a hole bored into the aluminum is the heat source. The material being heated never comes into contact with the HD cartridge heater.

Standard (Non-Stock) Sizes and Ratings

Heater Length (in)	Watts	Volts	Terminal Box Type	Tube Fitting Type	Thermocouple				Thermostat	Part Number
					Calibration Type	Style	Termination Type	Lead Length (in)		
6.5	300	120	Nema 4/7	—	J	Spring Adjustable	Std. Plug	60	—	CHX10010
6.5	300	208	—	—	—	—	—	—	Yes	CHX10070
6.5	300	240	Nema 4	—	K	Armor Cable Adjustable	Std. Plug	48	—	CHX10085
6.5	500	240	Nema 4	—	J	Spring Adjustable	Spade Lugs	48	—	CHX10135
6.5	500	208	Nema 4/7	—	—	—	—	—	Yes	CHX10148
6.5	750	208	—	—	J	Spring Adjustable	Spade Lugs	36	—	CHX10165
6.5	750	240	Nema 4	—	K	Armor Cable Adjustable	Std. Plug	60	—	CHX10182
12.5	900	240	Nema 4/7	HS	—	—	—	—	Yes	CHX10210
12.5	1000	240	Nema 4/7	—	K	Armor Cable Adjustable	Std. Plug	60	—	CHX10220
12.5	1200	240	Nema 4/7	HS	J	Spring Adjustable	Spade Lugs	36	—	CHX10235
12.5	1500	240	Nema 4/7	—	K	Armor Cable Adjustable	Std. Plug	48	—	CHX10242
12.5	1500	120	Nema 4/7	HS	K	Armor Cable Adjustable	Std. Plug	60	—	CHX10248

CHX-100 Series Circulation Heater

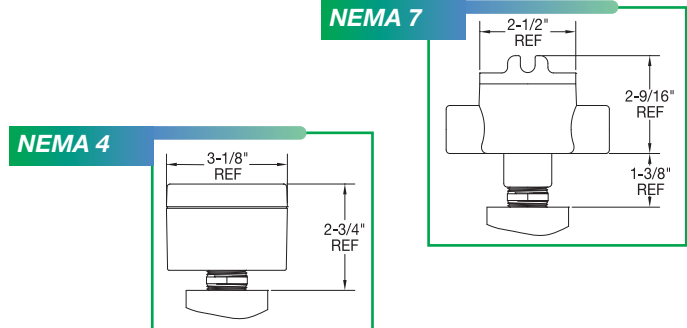
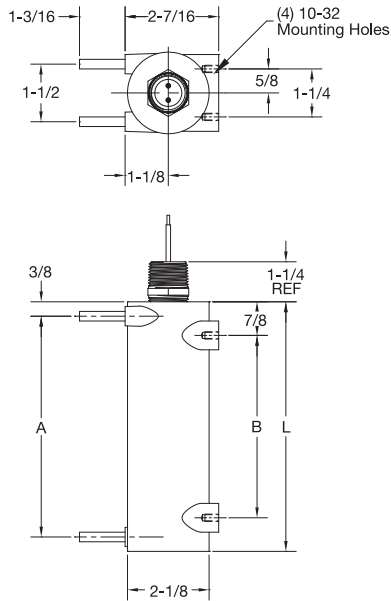

Ordering Information
To process your order or quotation, please specify the following information.

Length "L"	Inlet-to-Outlet Centerline "A"	Mounting Holes "B"	Flow Tube OD	Flow Tube Material	Used with Insulation Blanket
6.5	5.75	4.75	1/4	316 SS	BLK50001
12.5	11.75	10.75		Seamless	BLK50002

Heater Specifications:

Dimensions

Length "L": 6.5" 12.5" Custom _____

Electrical Specifications

Watts _____ (3,000W Max.) Volts _____ (240V Max., Single Phase only)

Termination Type

Type CN – NPT Fitting with 10" Leads

Terminal Protection Box

NEMA 4 NEMA 7

Flow Tube Fittings

None "FF" Flared Seal Fitting "HS" Hi-Seal Fitting
(See page 3-52 for complete details.)

Optional Temperature Sensor Specifications:

Calibration

Type J Type K

Bayonet Style T/C

None "Style 1" Spring Adjustable "Style 2" Armor Cable Adjustable
(See page 14-3 for complete details.)

Termination

"Style B" 2-1/2" Split Leads "Style S" Spade Lugs "Style P" Standard Plug
(See page 14-9 for details.)

Length

36" 48" 60" 72" 96" 120" 144"

Optional Thermostat:

Thermostat

High Limit Manual Reset (Standard) High Limit Automatic Reset (Optional)
(See page 13-55 & 13-66 for details.)

⚠ WARNING: Cancer and Reproductive Harm - www.P65Warnings.ca.gov.

CHX-200 Series Circulation Heater

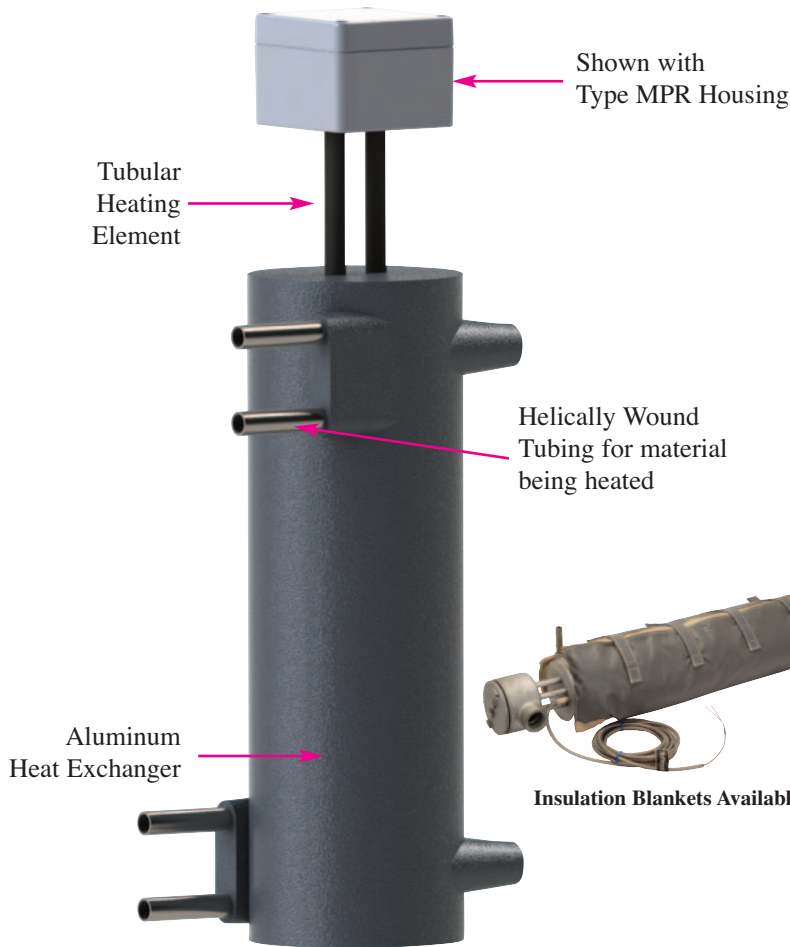

Standard Design Features

- * Seamless 316 SS Tubing for fluid flow
- * Cast-In Tubular Heater
- * Cast Aluminum heat exchanger body
- * Operating pressure up to 3000 PSI
- * Operating temperature up to 392°F (200°C)
- * Type C2 (General Purpose) housing with standoff

Optional Design Features

- * Process Thermocouple
- * Overtemperature Thermocouple
- * Type MPR (Moisture Resistant) or Type EP (Explosion Resistant) Housings

Typical Applications

- Solvent heating (MEK, NMP, ACT, EKC, others)
- Heating of Air, CO₂, Nitrogen and similar gases
- Heating of non-flammable gases
- De-ionized water heating
- Steam generation
- Glycol heating
- Heating ink in printing
- Diesel and Fuel heating
- Packaging sterilization
- Analytical instrumentation
- Food and beverage heating
- Coating and Paint heating

Construction

The CHX-200 circulation heater is a compact lightweight unit used for heating gases or liquids. The material being heated is pumped through the coiled seamless 316 SS tubing which has been cast into an aluminum body that acts as the heat exchanger. A tubular heating element is the heat source. The material being heated never comes into contact with the heating element.

Standard (Non-Stock) Sizes and Ratings

Heater Length (in)	Watts	Volts	Phase	Termination Type	Terminal Box Type	Tube Config.	Tube Fitting Type	Thermocouple			T-Stat	Part Number	
								Calibration Type	Style	Termination Type			Lead Length (in)
13.5	1500	240	1	T7	Type EP	Single	—	J	Spring Adjustable	Std. Plug	48	—	CHX20015
13.5	1500	480	1	T7	—	Single	—	—	—	—	—	—	CHX20022
13.5	2250	240	1	T	Type C2	Single	—	K	Armor Cable Adjustable	Std. Plug	60	—	CHX20037
13.5	1500	208	1	T	Type C2	Single	—	J	Spring Adjustable	Spade Lugs	48	—	CHX20042
13.5	3000	240	1	T7	Type MPR	Single	—	—	—	—	—	—	CHX20065
19.5	3000	240	1	T7	—	Single	—	J	Spring Adjustable	Spade Lugs	60	—	CHX20072
19.5	3000	208	1	T	Type C2	Single	—	K	Armor Cable Adjustable	Std. Plug	48	Yes	CHX20084
19.5	4500	240	3	T7	Type MPR	Single	HS	—	—	—	—	—	CHX20086
19.5	3000	240	1	T	Type C2	Dual	—	K	Armor Cable Adjustable	Std. Plug	48	—	CHX20094
19.5	4500	240	1	T	Type C2	Single	HS	J	Spring Adjustable	Spade Lugs	60	Yes	CHX20098
25.5	6000	480	1	T7	Type MPR	Dual	—	K	Armor Cable Adjustable	Std. Plug	48	—	CHX20105
25.5	7500	480	1	T7	Type MPR	Single	HS	K	Armor Cable Adjustable	Std. Plug	60	—	CHX20112
25.5	9000	240	3	T7	Type EP	Dual	—	K	Armor Cable Adjustable	Std. Plug	60	—	CHX20118
25.5	12000	240	3	T7	Type EP	Dual	—	K	Spring Adjustable	Std. Plug	60	—	CHX20122
25.5	12000	480	3	T7	Type EP	Single	—	K	Armor Cable Adjustable	Std. Plug	48	—	CHX20132

CHX-200 Series Circulation Heater

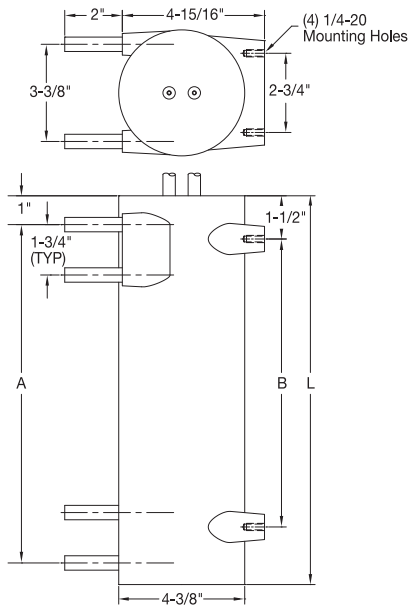

Type C2

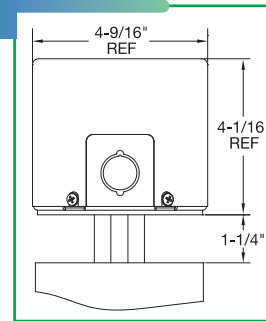

Type MPR

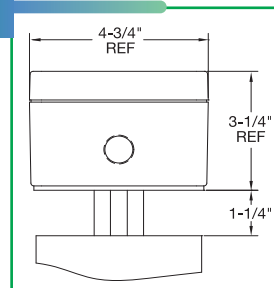

Type EP

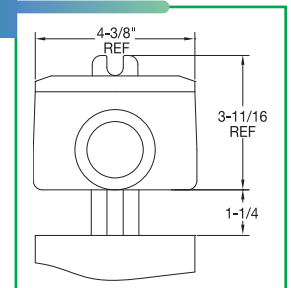

Length "L"	Inlet-to-Outlet Centerline "A"	Mounting Holes "B"	Flow Tube OD	Flow Tube Material	Used with Insulation Blanket
13.5	11.75	10	1/2	316 SS Seamless	BLK50003
19.5	17.75	16			BLK50004
25.5	23.75	22			BLK50005

Ordering Information

To process your order or quotation, please specify the following information.

Heater Specifications:

Dimensions

Length "L": 13.5" 19.5" 25.5" Custom _____

Electrical Specifications

Watts _____ (12,000W Max.) Volts _____ (480V Max.)

Single-Phase Three-Phase

Termination Type

Type "T" Type "T7" (See page 3-54 for details.)

Terminal Protection Box

Type C2 Type MPR Type EP (See pages 3-56 & 3-57 for details)

Flow Tube Configuration

Single Dual

Flow Tube Fittings

None "FF" Flared Seal Fitting "HS" Hi-Seal Fitting
(See page 3-52 for details.)

Optional Temperature Sensor Specifications:

Calibration

Type J Type K

Bayonet Style T/C

None "Style 1" Spring Adjustable "Style 2" Armor Cable Adjustable
(See page 14-3 for complete details.)

Termination

"Style B" 2-1/2" Split Leads "Style S" Spade Lugs "Style P" Standard Plug
(See page 14-9 for details.)

Length

36" 48" 60" 72" 96" 120" 144"

Optional Thermostat:

Thermostat

SPST DPST

NOTE: DPST requires larger Type C2 enclosure. Specify when ordering.
(See page 13-63 for details.)

⚠ WARNING: Cancer and Reproductive Harm - www.P65Warnings.ca.gov.

CHX-300 Series Circulation Heater

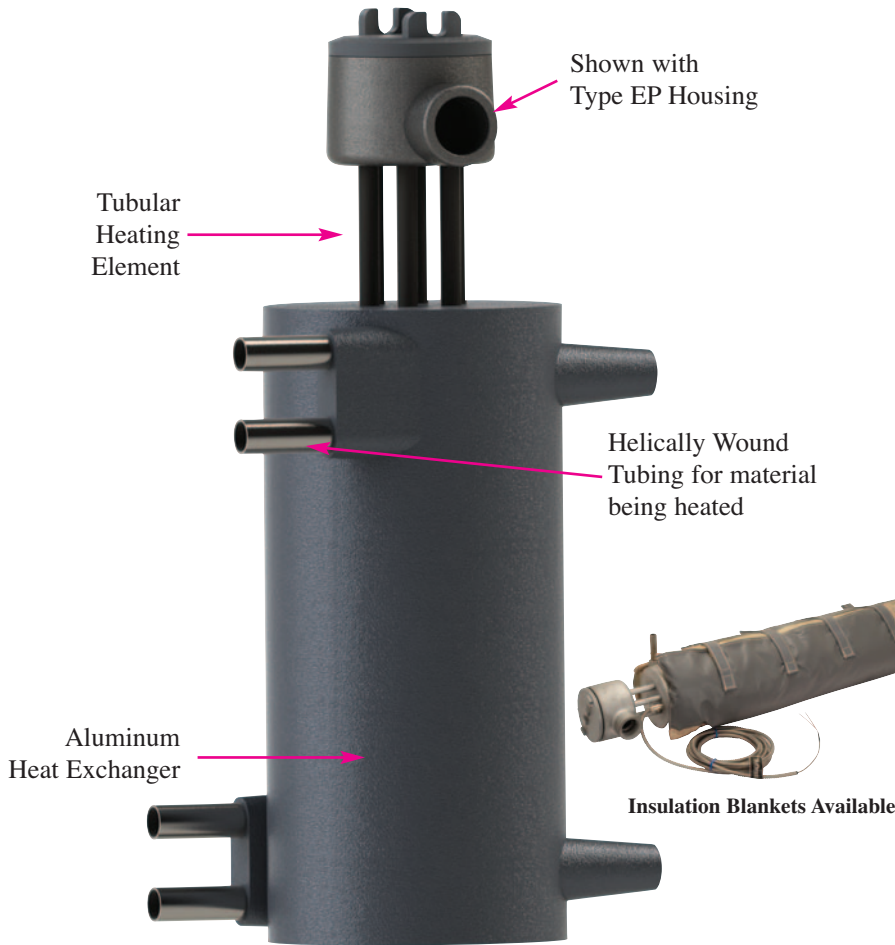

Standard Design Features

- * Seamless 316 SS Tubing for fluid flow
- * Cast-In Tubular Heater
- * Cast Aluminum heat exchanger body
- * Operating pressure up to 3000 PSI
- * Operating temperature up to 392°F (200°C)
- * Type C2 (General Purpose) housing with standoff

Optional Design Features

- * Process Thermocouple
- * Overtemperature Thermocouple
- * Type MPR (Moisture Resistant) or Type EP (Explosion Resistant) Housings

Typical Applications

- Solvent heating (MEK, NMP, ACT, EKC, others)
- Heating of Air, CO₂, Nitrogen and similar gases
- Heating of non-flammable gases
- De-ionized water heating
- Steam generation
- Glycol heating
- Heating ink in printing
- Diesel and Fuel heating
- Packaging sterilization
- Analytical instrumentation
- Food and beverage heating
- Coating and Paint heating

Construction

The CHX-300 circulation heater is a compact lightweight unit used for heating gases or liquids. The material being heated is pumped through the coiled seamless 316 SS tubing which has been cast into an aluminum body that acts as the heat exchanger. A tubular heating element is the heat source. The material being heated never comes into contact with the heating element.

Standard (Non-Stock) Sizes and Ratings

Heater Length (in)	Watts	Volts	Phase	Termination Type	Terminal Box Type	Tube Config.	Tube Fitting Type	Thermocouple			T-Stat	Part Number	
								Calibration Type	Style	Termination Type			
13.5	3000	240	1	T7	Type EP	Single	—	J	Spring Adjustable	Std. Plug	48	—	CHX30012
13.5	3000	480	1	T7	—	Single	—	—	—	—	—	—	CHX30016
13.5	4500	240	1	T	Type C2	Single	—	K	Armor Cable Adjustable	Std. Plug	36	—	CHX30022
13.5	3000	208	1	T	Type C2	Single	—	J	Spring Adjustable	Spade Lugs	48	—	CHX30028
13.5	4500	240	1	T7	Type MPR	Single	HS	—	—	—	—	Yes	CHX30036
19.5	6000	240	1	T7	—	Single	—	J	Armor Cable Adjustable	Spade Lugs	60	—	CHX30044
19.5	6000	480	1	T	Type C2	Dual	—	K	Spring Adjustable	Std. Plug	48	Yes	CHX30048
19.5	7500	240	3	T7	Type MPR	Single	HS	—	—	—	—	—	CHX30054
19.5	7500	480	3	T	Type C2	Dual	—	K	Armor Cable Adjustable	Std. Plug	60	—	CHX30056
19.5	9000	480	3	T	Type C2	Single	HS	J	Spring Adjustable	Spade Lugs	48	—	CHX30062
25.5	12000	480	3	T7	Type MPR	Dual	—	K	Armor Cable Adjustable	Std. Plug	36	—	CHX30068
25.5	12000	480	3	T7	Type MPR	Dual	HS	K	Spring Adjustable	Std. Plug	60	—	CHX30071
25.5	12000	240	3	T7	Type EP	Dual	—	K	Armor Cable Adjustable	Std. Plug	48	—	CHX30075
25.5	18000	240	3	T7	Type EP	Dual	—	K	Spring Adjustable	Std. Plug	60	—	CHX30078
25.5	18000	480	3	T7	Type EP	Dual	—	K	Armor Cable Adjustable	Std. Plug	48	—	CHX30084

CHX-300 Series Circulation Heater

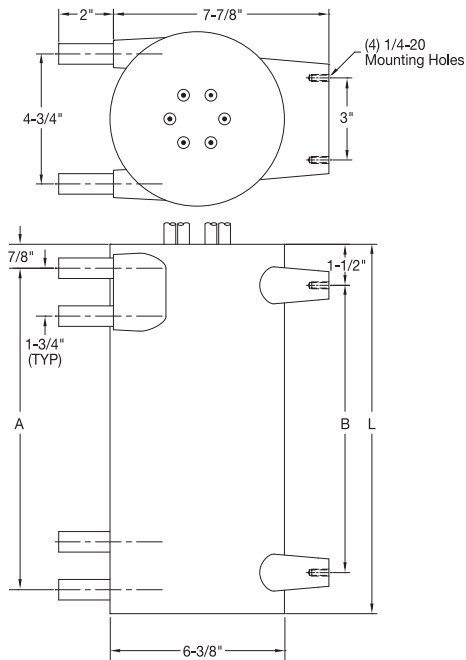

Type C2

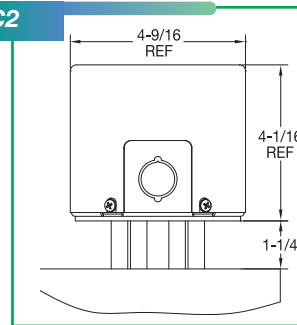

Type MPR

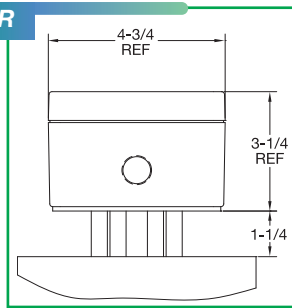

Type EP

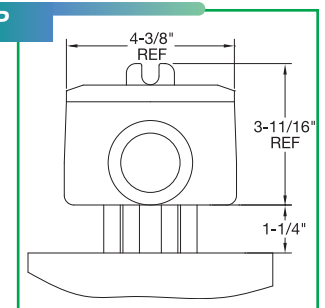

Length "L"	Inlet-to-Outlet Centerline "A"	Mounting Holes "B"	Flow Tube OD	Flow Tube Material	Used with Insulation Blanket
13.5	11.75	10	3/4	316 SS Seamless	BLK50006
19.5	17.75	16			BLK50007
25.5	23.75	22			BLK50008

Ordering Information

To process your order or quotation, please specify the following information.

Heater Specifications:

Dimensions

Length "L": 13.5" 19.5" 25.5" Custom _____

Electrical Specifications

Watts _____ (30,000W Max.) Volts _____ (480V Max.)

Single-Phase Three-Phase

Termination Type

Type "T" Type "T7" (See page 3-54 for details.)

Terminal Protection Box

Type C2 Type MPR Type EP (See pages 3-56 & 3-57 for details)

Flow Tube Configuration

Single Dual

Flow Tube Fittings

None "FF" Flared Seal Fitting "HS" Hi-Seal Fitting (See page 3-52 for details.)

Optional Temperature Sensor Specifications:

Calibration

Type J Type K

Bayonet Style T/C

None "Style 1" Spring Adjustable "Style 2" Armor Cable Adjustable
(See page 14-3 for complete details.)

Termination

"Style B" 2-1/2" Split Leads "Style S" Spade Lugs "Style P" Standard Plug
(See page 14-9 for details.)

Length

36" 48" 60" 72" 96" 120" 144"

Optional Thermostat:

Thermostat

SPST DPST

NOTE: DPST requires larger Type C2 enclosure. Specify when ordering.
(See page 13-63 for details.)

⚠ WARNING: Cancer and Reproductive Harm - www.P65Warnings.ca.gov.

Cast-In Heaters – Large Thermo-Platens

Engineered Solutions With Advanced Technology in Cast-In Thermo-Platens

Tempco specializes in innovative engineering and manufacturing of thermal components. Coupled with our diverse foundry and machine shop capabilities, this expertise provides the know-how behind our product line offering of large electrically heated platens that are manufactured by using our cast-in heater technology.

This casting process incorporates the heat source (tubular heating element) as an integral component of the platen. This process provides a more cost-effective and reliable approach than drilling holes for cartridge heaters or clamping inefficient and cumbersome-to-use strip heaters to the back surface of a platen.

Tempco's thermo-platens are made from aluminum, bronze and brass alloys. These materials provide excellent thermal conductivity for rapid heat transfer with uniform temperature gradients. To further enhance heat profiles, the formation and the location of the tubular heaters within the casting are precisely engineered using the latest computer design techniques.

When the process requires heating and cooling cycles, thermo-platens can be manufactured with the addition of stainless steel tubing to provide liquid cooling capabilities.

The working surfaces and/or contours of the thermo-platen can be machined to your specifications up to and including blanchard ground for extremely flat surface requirements.

Our capabilities for manufacturing large thermo-platens offer you the freedom to think big in your design requirements.

We offer complete engineering services and support, working with you every step of the way from prototype to production to ensure customer satisfaction.

There is no substitute for our acquired knowledge.

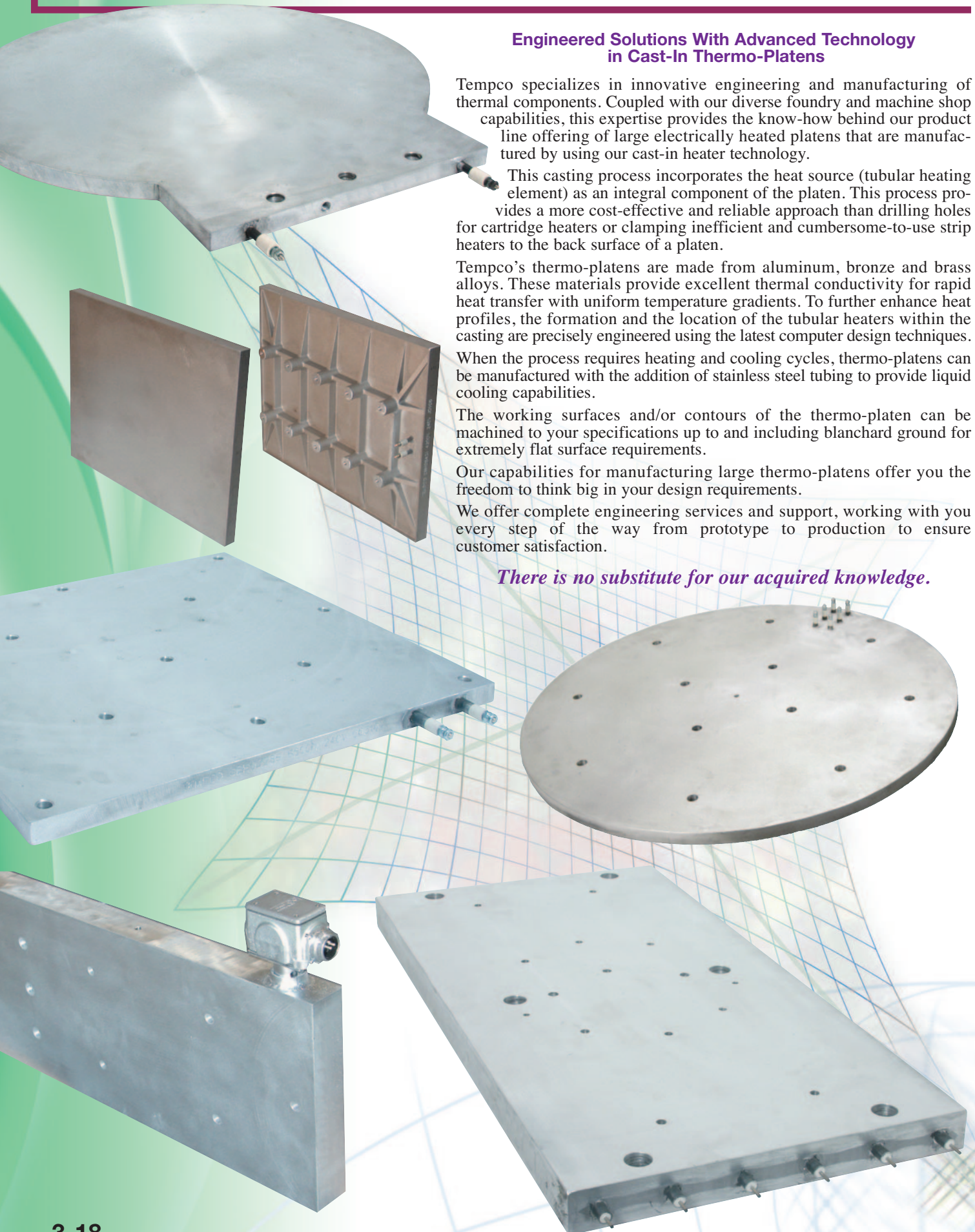

Cast-In Heaters – Large Thermo-Platens

Design Features & Options

- * **Castings:**
 - Aluminum up to 600 lbs.
 - Bronze & Brass up to 300 lbs.
(Recommended for high operating pressures and temperatures)
- * **Exceptionally Long Operating Life**
- * **Single- or Three-Phase Circuit**
- * **Surface Finishes: Electroless Nickel-Plated, Teflon®, Hard-Coat Anodizing, Magnaplate**
- * **Thermowells for Temperature Sensors**
- * **Excellent Heat Transfer**
- * **Maximum width 60" Maximum length 72"**
- * **Uniform Surface Temperatures**
- * **Machined to Customer Specifications**
- * **Heating & Liquid Cooling Functions**
- * **Various Heater & Cooling Tube Terminations**



Note: Cast-In Thermo-Platens are made to customer specifications. For technical assistance, engineering data and available options please refer

to pages 3-4 & 3-5. When ordering please provide detailed design drawings, including dimensions, critical tolerances, electrical ratings, watts, volts, single- or three-phase, and any other feature or special requirements.

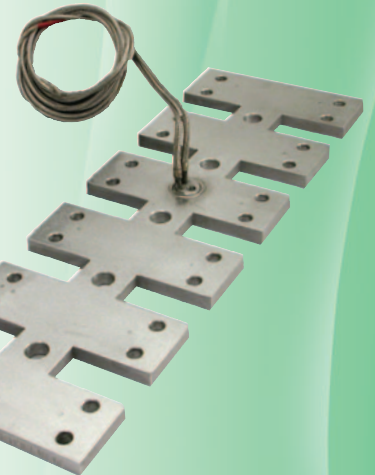
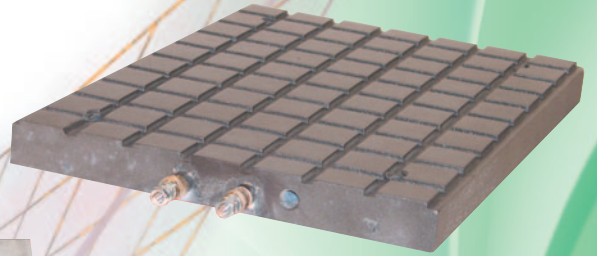
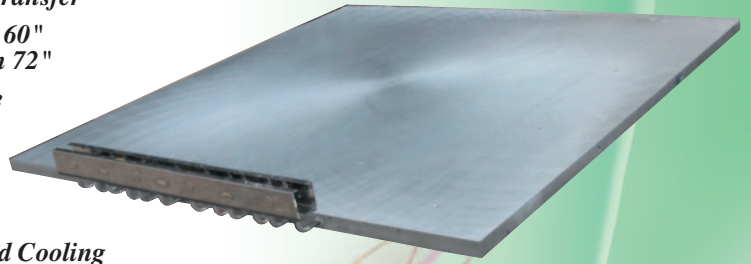

When Your Needs Call for **LARGER** Than **BIG**
Cast-In Thermal Platens & You Need Them **NOW** –
Look No Further Than **Tempco!**

We Can Do It – We Have the Technology!



Cast-In Thermal Components – Liquid Cool

Engineered Solutions With State-Of-The-Art Technology in Liquid Cool Aluminum Cast-In Thermal Components

You can count on Tempco to continue our tradition of leadership by providing cutting edge solutions as we address the needs and challenges of specialized segments of industries that depend on cooling for the operating efficiency and performance of their equipment.

As a result of market demand for such products, Tempco introduces our capabilities of producing a complete selection of made-to-order liquid cool aluminum cast-in thermal components, available in both complex geometrics or simple platens.

The thermodynamic relationship between the liquid heat transfer media circulating through the precisely formed and configured stainless steel cooling tube and the aluminum alloy casting maximizes heat removal efficiency. Tempco's liquid cool cast-in thermal component technology is a novel approach to clean, efficient and reliable process cooling of difficult and complex applications.

Consult Tempco with your challenging applications. Our capabilities for manufacturing these complex liquid cool thermal components offer you the advantage to think outside the box. Let the endless possibilities spark your imagination, allowing you the freedom to customize your design.

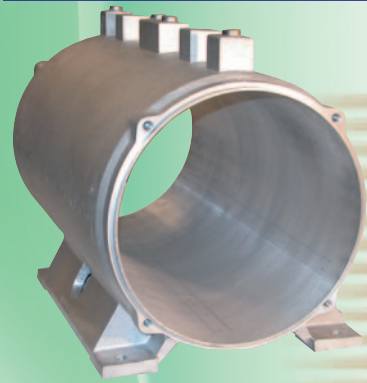

Cast Aluminum Motor Housing & Base with Integral Liquid Cool Capabilities
U.S. Patents: # 6222289 & #5939808



Let Tempco's Creative Team of Professionals Tackle Your Next Cast-In Liquid Cool Thermal Component Project. We Have the Technology, Infrastructure & Commitment to Exceed Our Customers' Expectations.

Thermo-Platens for Liquid Cooling of High Density Electronic Systems & Other Applications Requiring Flat Surface Cooling

In a world of compact designs with increased power densities, more heat is being generated than can be properly dissipated by conventional air blowers. For applications that have high-watt densities such as lasers, high-powered electronics, telecommunications, and semiconductor processing, liquid-cooled cold plates are the ideal high-performance heat transfer solution.

Mounting the components on an aluminum platen with internal liquid cooling tubes replaces forced air cooling to achieve and maintain lower electronic cabinet temperatures, thus increasing the operating service life of the individual components and the system.

When drilling and/or tapping is required for the cold plate application, Tempco will perform the machining to ensure that the product's integrity is not compromised.

Now You Can Give Your Electronics a Chill!

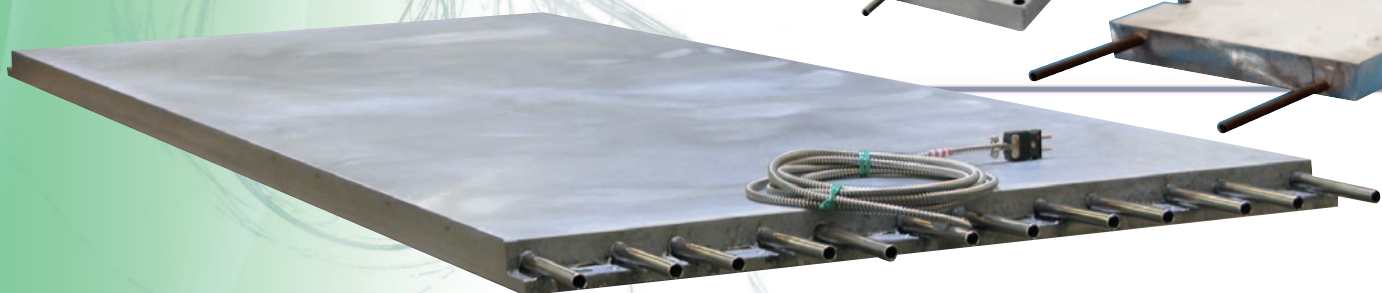
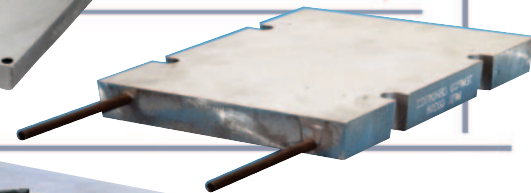
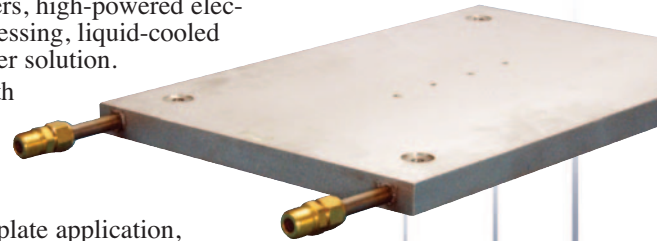
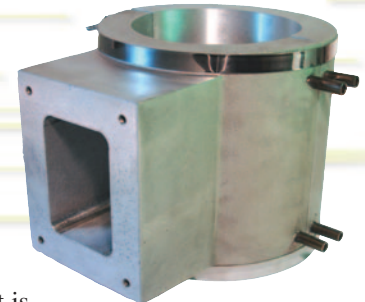

Thermo-Platen Specifications

Typical Cooling Tube Exit Locations For Cast-In Thermo-Platens

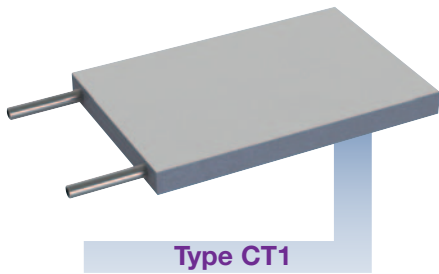

Cooling tubes exiting through the thickness toward the ends of the width or length.

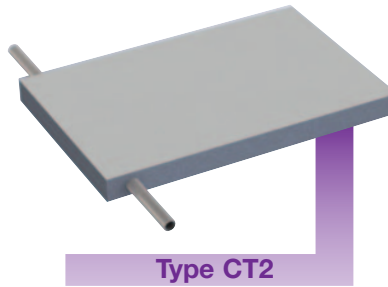

Cooling tubes exiting through the thickness opposite of each other toward the ends of the width or length.

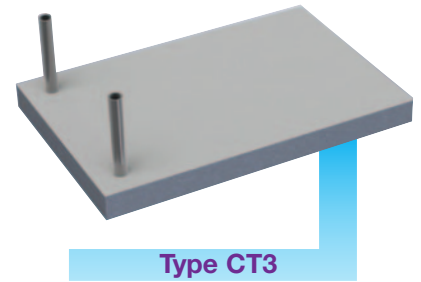

Cooling tubes exiting at the ends of the width or length through the top surface.

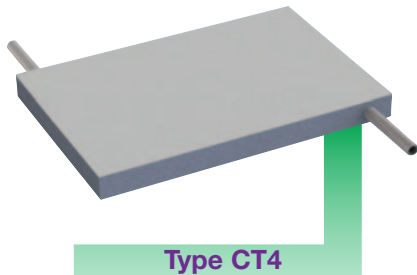

Cooling tubes exiting through the thickness at opposite ends of each other toward the ends of the width or length.

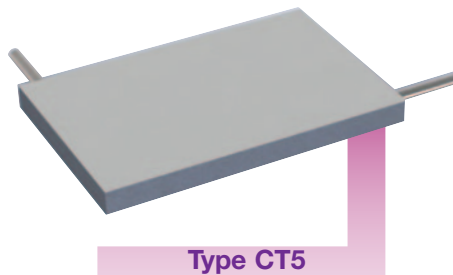

Cooling tubes exiting through the thickness at opposite ends of each other with one in the width and one in the length.

Complex Geometrics



Note: Cooling Tube Exit Locations for Complex Geometric Liquid Cool Thermal Components can be at any practical location for the shape and size of the individual thermal component.

For Cooling Tube Termination Optional Fittings and Accessories See pages 3-52 and 3-53.

Standard Cooling Tube Fittings For Cast-In Thermo-Platens



Type FF Flared Seal Fittings

Brass flared seal fittings are well adapted for low to medium pressure and resistant to mechanical pullout. Available for 3/8" and 1/2" diameter tubing with SAE 45° flare.

Diameter Tubing	Thread	Part Number
3/8"	5/8"-18	FTG-124-101
1/2"	3/4"-16	FTG-124-104



Type HS Hi-Seal Fittings

Hi-seal brass fittings are highly dependable under the most adverse conditions. For reliable and trouble-free service with ease of installation, we strongly recommend hi-seal fittings. Available for 3/8" and 1/2" diameter tubing. Male thread is 1/2" NPT for 1/2" tube and 3/8" tube.

Diameter Tubing	Part Number
3/8"	FTG-118-124
1/2"	FTG-118-116

CONTINUED

Heating Element Specifications

Continued from previous page...

Thermo-Platen Specifications

Typical Tubular Heating Element Exit Locations

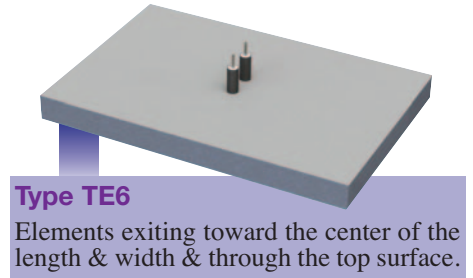
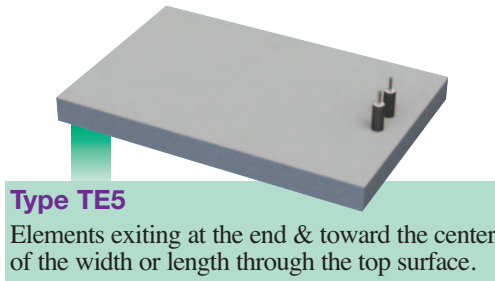
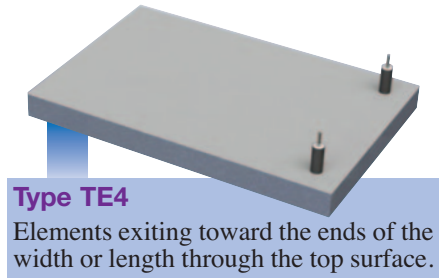
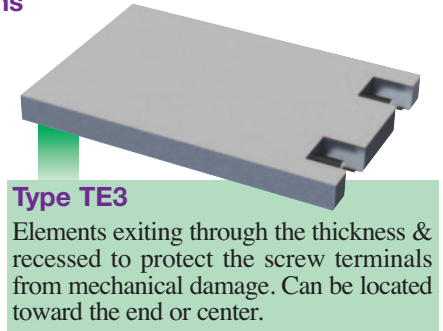
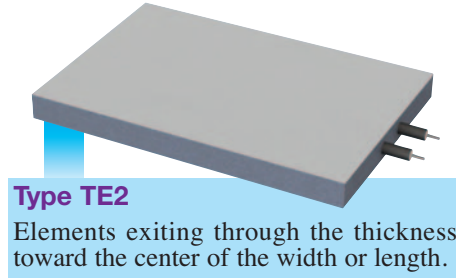
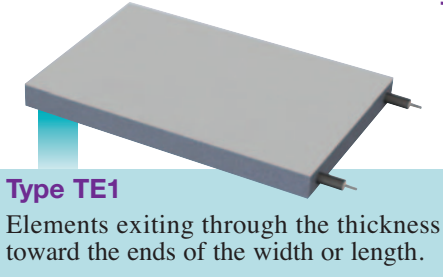

Most common thermo-platen terminations listed below;
for additional terminations and complete details, see pages 3-54 and 3-55.

Standard Tubular Heater Terminations for Thermo-Platens

Type S – Heavy Duty Ceramic Insulators (Standard Unless Otherwise Specified)

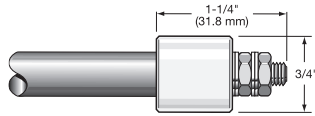

Type T7– Ceramic Insulator: same diameter as heating element

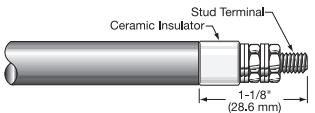

Type T – Mica Insulator: same diameter as heating element

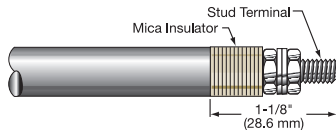

Type R – Mica Washers with 90° Blockhead Screw Terminal

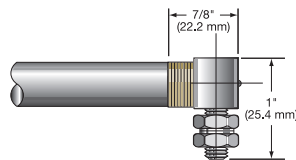

Type SF & SF9 – Quick-disconnect Spade Tabs

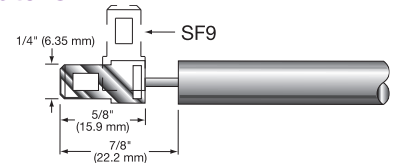

Type F – Flexible Leads with Fiberglass Sleeve



Type R1 – Flexible Stainless Steel Armor Cable



Type R1A – Stainless Steel Wire Overbraid



Type TS – Flexible Lead with Shrink-Down Teflon® Sleeve

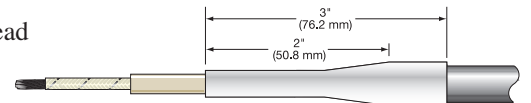

Typical Terminal Box Options and Locations

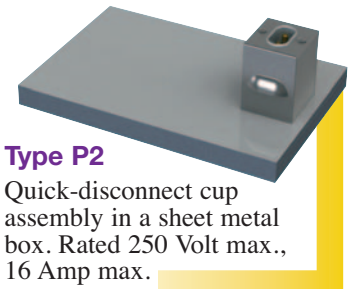
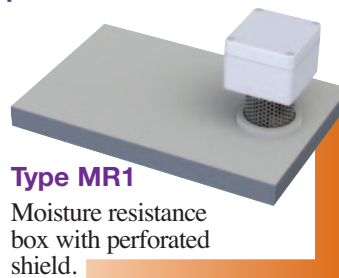
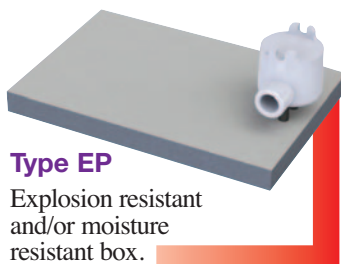

Thermo-Platen Quote Request Form

Ordering Information

To process your order or quotation, please specify the following information.



Note: Cast-In Thermo-Platens are made to customer specifications.

For technical assistance and engineering data, please refer to pages 3-4 & 3-5.

For available options, please refer to pages 3-21 & 3-22.

When ordering, please provide detailed drawings including dimensions, critical tolerances and any other feature or special requirements.

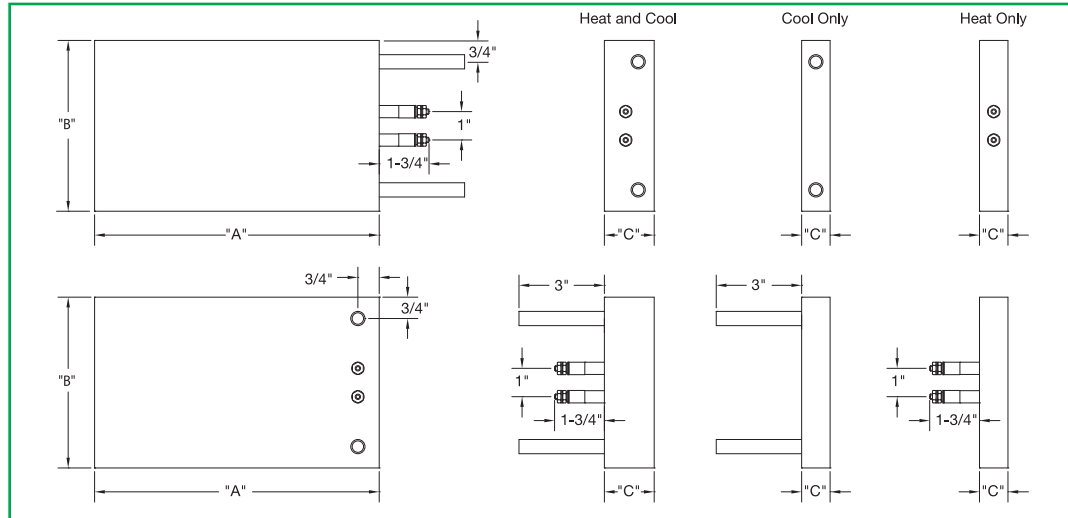

Thermo-Platen Type

Heat Only Cool Only Heat and Cool

Dimensions

Length "A" _____ Width "B" _____ Thickness "C" _____

Material Specifications

Aluminum Bronze Brass

Electrical Specifications

Watts each element _____ Volts each element _____ Phase _____

Element Exit Location

"TE1" "TE2" "TE3" "TE4" "TE5" "TE6" (see page 3-22)
 Other, Specify _____ (provide detailed drawing)

Termination Style

"S" Post Terminals "T7" Post Terminals "T" Post Terminals
 "R" 90° Blockhead "SF" Quick-disconnect Spade Tab
 "SF9" 90° Quick-disconnect Spade Tab "F" Plain Leads
 "R1" Armor Cable Leads "R1A" SS Wire Overbraid "TS" Leads and Shrink Sleeve
 "P1" Quick-Disconnect Cup assembly Other, Specify _____ (See page 3-22)

Terminal Protection Box

None "C2" Standard "EP" Explosion Resistant "MR1" Moisture Resistant
 "P2" Quick-Disconnect Cup assembly

Cooling Tube Exit Locations

Type CT1 Type CT2 Type CT3 Type CT4 Type CT5
(See page 3-21 for details)

Cooling Tube Specifications

1/4" O.D. SS 3/8" O.D. SS 1/2" O.D. SS
 3/8" O.D. Incoloy® 1/2" O.D. Incoloy® Dual Cooling Tubes
 Standard Wall Thickness Other Wall Thickness, Specify _____
(See page 3-5 for Standard Wall Thickness Information)

Cooling Tube Fittings

"FF" Flared Seal "HS" Hi-Seal Fittings
 Other, Specify _____ (See page 3-52)

Surface Finish

Machined or As-Cast. *Indicate surfaces to be machined.*

Special Cast-In Features

Holes, Cutouts, Slots, Bevels, Mounting Studs, Stand-Offs and Taper Angles.
For special features, a detailed drawing is required.

WARNING: Cancer and Reproductive Harm - www.P65Warnings.ca.gov.

TEMPCO Offers the Largest Selection of Quality Cast-In Heaters for Plastics Processing

Over 15,000 Existing Designs on File and Growing



Single Source Advantage – From Beginning to End

Tempco has set industry standards as the leading manufacturer of Aluminum, Brass and Bronze Cast-In Heaters in a variety of standard designs and styles for the plastics processing industry.

However, we realize not every Cast-In Heater application can be solved by one of our standard products. Our solutions help our customers and create new opportunities for Tempco. It is our engineering talents and vast application knowledge that provide a winning combination for solving specific application problems with custom designed and manufactured Cast-In Heaters.

The design, engineering and manufacturing of Tempco Cast-In Heaters is done under one roof—administered by a team of experienced professionals with a vast knowledge in product design and proven foundry expertise, producing the best quality Cast-In Heaters money can buy.

Computer Designed Tubular Heaters manufactured under our rigid quality control standards are the heat source for the Cast-In Heater. They can be formed into endless configurations to accommodate any practical Cast-In Heater shape.

Wood Pattern Shop A full-service in-house wood pattern shop builds, modifies and maintains patterns.

Foundry Capabilities Tempco's modern foundry produces Low Pressure Permanent Mold, Tilt Pour Permanent Mold, and No-Bake Mold Sand Castings. Our team of professionals with years of practical experience provides the knowledge essential for producing quality cast-in heaters for the plastics processing industry.

Cast-In Heaters are produced in-house by a team of experts for unparalleled quality!

Tempco's Exclusive **Cool TO-THE Touch™** Heating & Air Cooling Shroud Systems for Extrusion Processing Can be found on pages 3-26 through 3-32

Consult us with your requirements. No one can do it better than Tempco – Let us prove it!

SATISFACTION GUARANTEED!

Plastics Extrusion Processing

Our Cast-In Band Heaters have proven to be the most effective method for heating and cooling the barrels of extruders used in the plastics processing industry.

Tempco offers Cast-In Band Heaters with liquid or air cooling. Liquid cooling incorporates tubing cast in as part of the heater assembly, allowing water or heat transfer solutions to remove excess heat. Air cooling uses fins cast to the Outer Diameter surface of the band heater;

blowers and specially designed shrouds aid in heat removal.

Aluminum is the predominant alloy used for the Cast-In Heater. Copper-based alloys (Bronze and Brass) are used when the required operating temperatures exceed the maximum for Aluminum. Bronze or Brass are recommended for heated platens in molding presses as they can withstand a greater force of pressure per square inch than Aluminum.

Typical Plastics Processing Applications For Tempco's Cast-In Heaters

- ➔ Extruders
- ➔ Blow Molding
- ➔ Injection Molding
- ➔ Extrusion Die Heads
- ➔ Silk-Screening
- ➔ Laminating Equipment
- ➔ Heat Sealers
- ➔ Vacuum Forming
- ➔ Compression Molding
- ➔ Polymer Compounding

When your needs call for Cast-In Heaters for Plastics Processing & you need them NOW!
Look no further than Tempco – we have an extensive inventory.
Custom manufactured with the best lead times in the Industry!

Experience Our Value-Added Services that are Second to None

Minimum Casting Thickness vs. Heating Element and/or Cooling Tube Diameters

Casting Thickness	Maximum Available Element Diameter	Maximum Available Cooling Tube Diameter	Maximum Element and Cooling Tube Combination
	Heat Only	Cool Only	Heat and Cool
5/8" (15.9 mm)	.260	1/4	—
3/4" (19.1 mm)	.375	3/8	—
1" (25.4 mm)	.430	1/2	—
1-1/4" (31.8 mm)	.430	1/2	.260 and 3/8
1-3/8" (34.9 mm)	.430	1/2	.315 and 1/2
1-1/2" (38.1 mm)	.430	1/2	.430 and 1/2
1-5/8" (41.3 mm)	.430	1/2	.430 and 1/2
1-3/4" (44.5 mm)	.430	1/2	.430 and 1/2
Finned Casting			
3/4" (19.1 mm)	.375	—	—
7/8" (22.2 mm)	.430	—	—
1" (25.4 mm)	.430	—	—
1-3/4" (44.5 mm)	.430	—	—

Casting Size & Weight Limitations

	Cylindrical	Platen
Minimum Inside Diameter:	1" (25.4 mm)	—
Maximum Inside Diameter:	48" (1219 mm)	—
Minimum Width:	—	1-1/2" (38.1 mm)
Maximum Width:	—	60" (1524 mm)
Minimum Length:	1-3/4" (44.5 mm)	4" (102 mm)
Maximum Length:	40" (1016 mm)	72" (1829 mm)
Finish:	125 RMS Standard or to customer spec.	
Gap (two-piece cylindrical cast-in band heaters):	1/4" (6.4 mm) top and bottom or to customer specification	
Maximum Weight:	Aluminum— 600 pounds Bronze & Brass— 300 pounds	

NOTES: Cylindrical heaters are made with two half-round heaters. Cast-In thermal components can be made in any practical size, weight and geometric shape.

CNC Machining

There are certain dimensional and/or finish tolerances or geometry that cannot be produced as cast and must be machined. Tempco offers a full service state-of-the-art machine shop featuring various types of CNC machine tools to perform all of the precision machining required—from simple to complex contour geometrics, including turning and/or boring, with repeatable accuracy from one machined casting to the next. Machinists also build and maintain permanent mold tooling for the low pressure and tilt-pour gravity feed casting processes.



Heating Element Electrical Specifications

Tubular Heater Diameter	.260"	.315"	.375"	.430"
Maximum Volts	240	277	480	600
Maximum Amps Per Element	15	30	40	40
Maximum Watt Density:	Aluminum Alloy—35 W/in ² on the element Bronze or Brass—45 W/in ² on the element			
Resistance Tolerance:	+10%, -5%			
Wattage Tolerance:	+5%, -10%			
<i>Three Phase available depending on casting size. Ground Studs can be added to most cast-ins.</i>				



Note: Tempco-Pak mineral insulated cable heaters can be used in place of tubular heating elements to fit physical constraints not possible with conventional heating elements. See catalog Section 5 for more details.

Maximum Alloy Surface Temperatures

Material	Max. Surface Temperature °F (°C)
Aluminum 319	700 (371)
Aluminum 356	750 (399)
Bronze	1350 (732)
Yellow Brass	1200 (649)

Cooling Tube Materials for Castings with Liquid Cooling

Tube Material	Tube OD and Wall Thickness
Stainless Steel (Standard)	1/4" O.D. × .028 wall
Stainless Steel (Standard)	3/8" O.D. × .035 wall
Stainless Steel (Standard)	1/2" O.D. × .049 wall
Stainless Steel (Optional)	5/8" O.D. × .049 wall
Incoloy® 840 (Optional)	1/2" O.D. × .049 wall
Tubing with heavier wall thickness is available upon request.	

Agency  US  Approvals

Cast-In Heater Elements are UL recognized under
UL File Number E90771 and CSA File 043099.

If you require UL Agency Approval, please specify when ordering.

Are You Operating Your Extruders with Liquid Cooling?

If You Answer Yes –

Then You Are SO Ready for a

TEMPCO

EXTREME

MAKEOVER

With Our Exclusive

Cool TO-THE Touch™

Shroud Systems

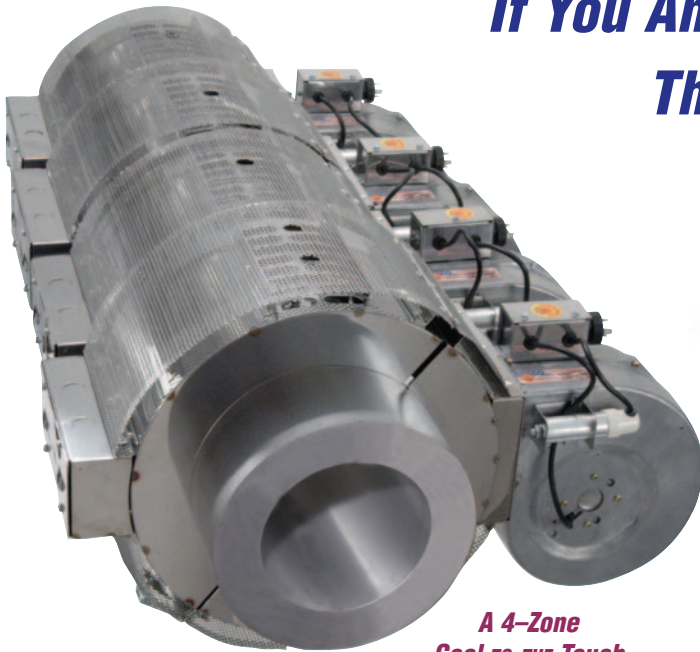

**A 4-Zone
Cool TO-THE Touch
Shroud System**

Let Tempco's state-of-the-art technology convert your extruder's existing heating and cooling system from antiquated, inefficient and costly to modern, highly efficient, and cost-effective.

We invite you to energize your extrusion business with Cool TO-THE Touch. It can take your profits to the next level.

The Challenge

We understand that choosing to make a change can be challenging and full of "What-If's?" Not to worry – Tempco warrants the performance of our systems. Our expert team will be with you every step of the conversion to help you select the ideal system for your extrusion lines.

Cool TO-THE Touch is a fully integrated system that offers powerful functionality, user-friendly installation and operation, customizable features and other benefits you simply will not find in any existing extruder heating and cooling system.

These highly engineered products are designed for durability and trouble-free operating performance.

It can very well be the most important step you take when you purchase a new extruder or rebuild existing equipment.

Experience the benefits and advantages offered by upgrading to Cool TO-THE Touch Shroud Systems.

Take your extrusion operation to the next level of technology with Tempco at your side.

There is nothing to lose, except. . .

The entire closed loop recirculating system which includes: chiller, heat exchanger, heat transfer fluid, and all associated piping and electrical components.



Let's Not Forget About This!!

Think about all the great changes ahead for your business – when you no longer have to babysit your unreliable, maintenance nightmare on your extruder heating and cooling system.

It's a Reality – Extreme Makeover for Extruders Is Finally Here! Take Advantage of It If You Are . . .

Purchasing a New Extruder

Specify to your machine builder to install one of Tempco's exclusive high-efficiency Cool TO-THE Touch heating and air cooling systems.

**SMALL
INVESTMENT**

**BIG
RETURN**

Retrofitting

Outdated air cooled systems can be retrofitted with Tempco's efficient air cooled shroud designs without replacing your existing heaters.

**Add Value
to Your
Extrusion
Process**

Rebuilding

An outdated, high maintenance, low efficiency liquid cooled system can be rebuilt with one of Tempco's turnkey Cool TO-THE Touch heating and air cooling systems.

Improve Your Bottom Line

Designed for Durability and Trouble-Free Operating Performance

Tempco's **Finned Cast-In Heaters** with bolt clamping are exclusively designed to work with **Tempco's Cool TO-THE Touch Shroud Systems**. They are manufactured with special high-efficiency fins and low overall mass cross-section for maximizing thermodynamics.



**Unmatched Quality Shroud System
& Finned Cast-In Heater**

Design Features

- * *Reduced operating costs*
- * *Quick, easy installation*
- * *Greater Reliability*
- * *Thermally efficient heating & cooling characteristics*
- * *Reduces costly downtime*
- * *Exceptional Cast-In Heater life*
- * *Eliminates expensive closed loop liquid cooling systems*
- * *Rugged, Durable & Appealing Design*

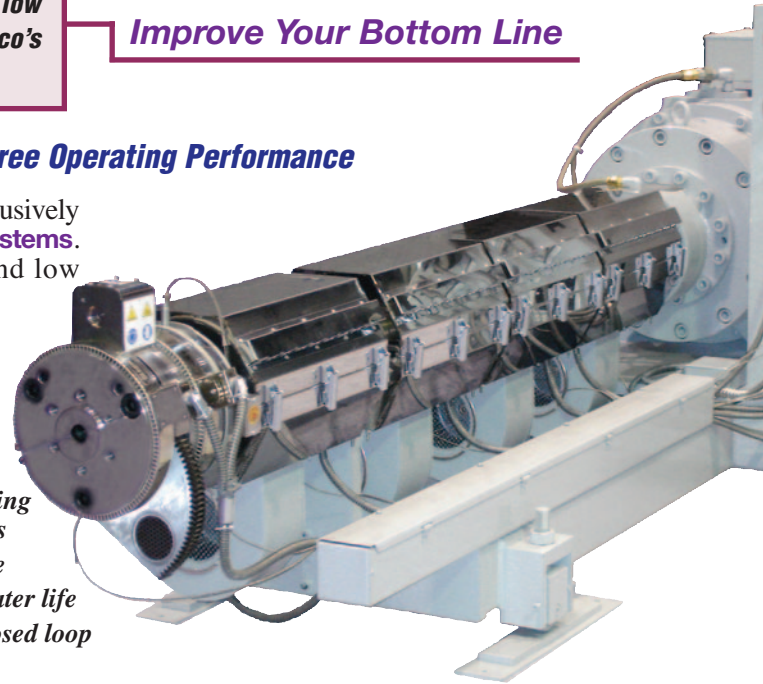

Liquid Cooling Cast-In Band Heaters vs. Cool TO-THE Touch Air Cooling Shroud Systems

Liquid Cooling

Up to now Liquid Cooling Cast-In Band Heaters have been the predominant method of controlling the melt temperature of extrusion barrels. Although effective in removing heat from the extrusion process, there are a number of drawbacks that are primarily maintenance related.

Extruders using liquid cooled Cast-In Heaters can be subject to unpredictable and untimely failures of the cooling tube assemblies, resulting in extremely costly downtime to the processor. Inherent maintenance problems include stress corrosion cracks, linear thermal expansion of the heater body, and clogging of the tubes due to accumulation of mineral deposits. Additionally, Liquid Cooled Cast-In Heaters require an expensive cooling tower or heat exchange system, extensive plumbing systems and labor for installation.

A Change Is In The Air

Tempco-designed air cooled systems have evolved considerably and become more thermally efficient as a result of geometric changes and implementation of sophisticated shrouding and air flow techniques. Optimized direction and ducting of airflow, coupled with selection of the proper blower CFM, are important to ensuring that the air cooling technique removes the proper amount of heat from the extrusion barrel. Air Cooled Cast-In Heaters are virtually maintenance free and therefore, when properly installed and applied, have the capability to far outlast and perform their liquid cooled counterparts.

Consult Tempco With Your Requirements. We Welcome Your Inquiries.

(800) 323-6859 • Email: sales@tempco.com

3 Turnkey State-Of-The-Art Systems to Improve Operating Efficiencies in Plastic Extrusion Equipment

Designed for Durability, Ease of Installation and Trouble-Free Service . . .

These highly engineered heating and cooling systems are an innovative concept in product design, offering a very efficient means to heat and cool the barrels of plastic extruders. They provide cooling efficiencies equal to or better than conventional liquid cooled cast-in aluminum band heaters.

These shroud designs are made with stainless steel sheet metal, cast aluminum construction.

These systems are self-contained and can be supplied as turnkey ready-to-go, requiring minimum labor and installation cost, and drastically reducing downtime and maintenance upkeep compared to conventional liquid cooling and heating cast-in band heaters.

Experience all the advantages offered by Tempco's exclusive **Cool TO-THE Touch High-Efficiency shroud and aluminum finned cast-in band heater designed system.**



The engineering of these two components is perfectly matched to work in tandem, offering thermally efficient heating and air cooling characteristics and eliminating the shortcomings of liquid cool cast-in aluminum band heaters

Improve Efficiencies in Extrusion Processing

Need Assistance Selecting a System? We Welcome Your Inquiries.

If you have a special application requiring a custom manufactured system or need assistance selecting one of our standard systems for a new or existing installation, consult Tempco with your requirements. We offer complete engineering services and support, working with you every step of the way to ensure customer satisfaction.

Selection Guide – Plastic Extruder Heating and Cooling Shroud Design Systems

	Shroud Style Construction	Recommended Heater Types	Barrel Diameter Range		Zone Length Range	
			Min.	Max.	Min.	Max.
 1	Cool TO-THE Touch™, Page 3-26 Inner Stainless Steel Solid Layer; Outer Stainless Steel Perforated Layer	Tempco Finned Cast Aluminum Heaters, Vented Ceramic Band or Maxiband Heaters	3" 76 mm	16" 406 mm	5" 127mm	36" 915 mm
 2	Multi-Versal, Page 3-33 Single Stainless Steel Solid Layer	Tempco Finned Cast Aluminum Heaters, Vented Ceramic Band or Maxiband Heaters	3" 76 mm	16" 406 mm	3-3/4" 95 mm	36" 915 mm
 3	Arctic Cast®, Page 3-37 Single Cast Aluminum Solid Layer	Tempco Finned Cast Aluminum Heaters	4" 102 mm	16" 406 mm	6-1/2" 165 mm	30-1/2" 775 mm

Cool TO-THE Touch Extruder Heat/Cool System

Tempco's Cool TO-THE Touch extruder heat/cool systems are custom engineered to provide optimal heating and cooling while providing personnel safety with a Cool Touch perforated outer layer. These systems are designed with finned cast-in heaters that optimize overall system efficiency.

The reflective inner layer of the shroud decreases the heat-up cycle, reducing energy consumption. The "maxi-flow" unrestricted blower port directs inlet air to the hottest part of the casting and distributes it evenly over the entire cross section of the zone.

1 – Cool TO-THE Touch Construction

Cool TO-THE Touch

Dual Layer Shroud with Inner Stainless Steel Solid Layer (thermally isolated from heater) and Outer, Cool to the Touch, Perforated Stainless Steel Layer for Maximum Venting and Heat Dissipation

Usage Requirements

The Cool TO-THE Touch Construction Style achieves best results when built for Tempco's High-Efficiency Finned Cast-In Heaters.

Cool TO-THE Touch Construction Details

Dual Layer Shroud

- * *Inner Stainless Steel solid layer – radiation shield that directs the cooling air flow over the heater*
- * *Outer Stainless Steel perforated layer – isolates hot surfaces from contact (cool touch)*

Shroud Assembly Features

- * *Two Mounting Styles are available:*
 - ➔ *Hinge with Barrel Clamps – designed for ease of installation*
 - ➔ *Two Individual Halves with Barrel Clamps (Two-Piece) – used where installation space is tight or mounting is difficult*
- * *Internal Support Straps or Support U-Bolt on blower mount half of shroud permits shroud to be opened for servicing without removing unit from barrel*
- * *Anti-Rotate Tabs – used only with Finned Cast-In Heaters to prevent shroud from radial and axial movement around the barrel*
 - ➔ *Tabs are cast as part of the heater (may require a Terminal Box)*
- * *Blower Options – See page 3-41 through 3-43 for Complete Details*
 - ➔ *Single or Dual Tempco Recommended Blowers available from 148 CFM up to 1210 CFM at 115V or 230V, or 480V 3-Phase*
 - ➔ *Customer Specified blower*
 - ➔ *Blower not required for Heat-Only Shrouds*
- * *Blower Location*
 - ➔ *Horizontal or Vertical Orientation*
 - ➔ *Extension Housings Available*
- * *Standard separate top Air Outlet*
- * *Optional Air Outlet Features Include:*
 - ➔ *Air Outlet Shield deflects air flow out of shroud and shields shroud from external solid contamination*
 - ➔ *Air Outlet combined with Terminal Box*
 - ➔ *Alternate Radial Air Outlet locations available*
- * *Air-Inlet Baffle Optional*
- * *Vent Hole(s) Optional*

Cool TO-THE Touch shown with optional dual blowers mounted vertically with knockouts for heater termination(s) and top vertical air outlet



Heater Type and Components

- * *Recommended Heater Types – Finned Cast-In Heaters with standard 1/4" gap between heater halves, Ceramic Band and Maxiband Heaters*
- * *Power Input Terminal Box with 7/8" dia. K.O. for 1/2" conduit:*
 - ➔ *Standard 10-32 stud termination with ceramic or mica insulator*
 - ➔ *With Louvered Cover – used when terminal box is separate from air-outlet*
 - ➔ *Stainless Steel Screen – used when terminal box is combined with air outlet*
- * *Power Input through Blower Mount – input wiring through knockouts in blower mount eliminates terminal box and facilitates ease of heater service*

Sensing and Controlling

- * *Existing Zone Control Probe – Shroud System can be designed per customer specifications*
- * *Tempco supplied Zone Control Probe*
- * *Tempco customized Power Control Panel designed to complete Your Thermal Loop System*

Ordering Information

See Page 3-36 for complete Ordering Information.

Existing Cool TO-THE Touch Extruder Heat/Cool Systems

Horizontal and Vertical Blower Motor Mount Design Specifications

The following partial listings are part numbers and specifications for shroud designs that Tempco has engineered and manufactured. Each item listed below can be modified to fit customer requirements.

Zone Control Probes are placed per customer specifications. See page 3-29 for complete details.

Barrel OD (Shroud ID)	Shroud Width	Shroud OD (in)	Blower Location (in)	Air Outlet Location (°)	Terminal Box Location (°)	Blower CFM (°)	Maximum Heater OD	Heater Part Number (in)	Wattage Per Shroud	Heater Voltage	Ref. Drawing Number	Shroud Part Number
4.25	9.25	10.06	270	90	0	273	7.75	CBH14315	3000	240	7	ASJ00421
4.5	10.06	9.81	180	0	45	358	7.5	CBH14322	3600	230	2	ASJ00423
5	9	10.56	180	0	0	273	8.25	CBH13803	4000	240	1	ASJ00367
5	13	10.81	180	0	0	358	8.5	CBH13011	6000	230	1	ASJ00281
5	13	11.56	180	0	45	458	9.25	CBH05677	4000	230	2	ASJ00381
5	13.63	10.81	180	0	0	358	8.5	CBH13387	6600	230	1	ASJ00315
5	14	10.31	180	0	45	458	8	CBH14316	6000	230	2	ASJ00422
5	18	10.56	180	0	0	550	8.25	(2)CBH13803	8000	240	1	ASJ00366
5.12	12	10.94	270	0	0	358	8.63	CBH13659	5600	400	5	ASJ00350
5.5	18.5	11.81	180	0	90	N/A	9	CBH13012	7000	200-3PH	3	ASJ00279
6	10.5	11.81	270	90	90	550	9.5	CBH12250	4000	220	8	ASJ00238
6.25	13.63	11.56	180	0	0	485	9.25	CBH13664	6000	230	1	ASJ00346
6.25	15	11.56	180	0	0	550	9.25	CBH14306	8250	240	1	ASJ00417
6.38	8	12.19	270	90	0	273	9.88	CBH13572	4000	240	7	ASJ00333
6.38	16	12.19	270	90	0	358	9.88	CBH13573	7000	240	7	ASJ00332
6.5	11	12.81	180	0	90	265	9.75	CBH12061	4600	240	3	ASJ00223
6.5	15.63	12.06	180	0	0	550	9.75	CBH13388	10000	240	1	ASJ00316
6.5	18	11.81	270	0	0	550	9.5	N/A	N/A	N/A	5	ASJ00341
6.5	18	12.81	180	0	90	550	9.75	CBH12060	7600	240	3	ASJ00222
6.5	21	11.81	270	0	0	550	9.5	CBH14189	8800	230	5	ASJ00403
6.63	17.25	12.94	270	0	0	1200	10.38	CBH13936	8800	240	5	ASJ00378
6.63	17.5	12.19	270	0	0	550	9.88	CBH13659	7500	230	5	ASJ00344
6.64	17.63	12.45	270	0	0	550	10.14	CBH13806	8720	240	5	ASJ00371
7	19	13.06	270	90	90	1200	10.75	CBH14114	7200	480	8	ASJ00396
7	21.5	14.06	180	0	N/A	550	11.25	CBH12045	4700	480	4	ASJ00220
7.5	12	12.81	270	0	0	485	10.5	CBH13701	6500	240	5	ASJ00351
7.5	17.5	13.56	180	0	90	1200	10.75	CBH12000	7500	240	3	ASJ00213
7.5	18.5	12.69	270	0	0	550	10.38	CBH13852	9000	230-3PH	5	ASJ00372
7.5	18.5	13.31	270	0	0	1200	11	CBH14099	9000	575-3PH	5	ASJ00394
7.5	19.5	13.82	270	0	0	797	11	CBH12232	11250	240	5	ASJ00228
7.5	20	12.81	180	0	0	550	10.5	CBH13010	9500	230	1	ASJ00280
7.5	20.5	12.81	180	0	0	1200	10.38	CBH13495	10000	240-3PH	1	ASJ00323
7.5	22.5	13.31	180	0	90	797	10.5	(2)CBH13219	8600	208	3	ASJ00293
7.5	23.5	12.81	180	0	0	1200	10.5	CBH13652	10000	240-3PH	1	ASJ00342
7.5	24	12.81	270	0	0	550	10.5	CBH13700	12500	240	5	ASJ00352
7.63	12	12.95	270	0	0	358	10.63	CBH13762	5350	230	5	ASJ00362
7.63	13.5	12.95	270	0	0	358	10.63	CBH13714	3480	230	5	ASJ00359
7.63	14.38	13.44	270	0	0	550	11.125	CBH14329	7000	230	5	ASJ00426



Note: Reference Drawings can be found on page 3-32.

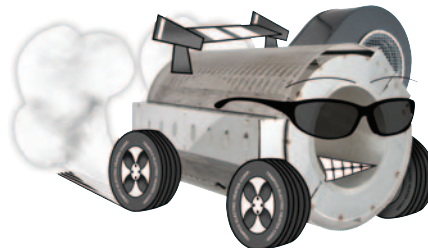

These Energy Conserving Units Out-Perform All Other Plastic Extruder Barrel Heating & Cooling Products.



Existing Cool TO-THE Touch Extruder Heat/Cool Systems

Horizontal and Vertical Blower Motor Mount Design Specifications (continued)

The following partial listings are part numbers and specifications for shroud designs that Tempco has engineered and manufactured. Each item listed below can be modified to fit customer requirements. Zone Control Probes are placed per customer specifications. See page 3-29 for complete details.

Barrel OD (Shroud ID)	Shroud Width	Shroud OD (in)	Blower Location (in)	Air Outlet Location (°)	Terminal Box Location (°)	Blower CFM (°)	Maximum Heater OD	Heater Part Number (in)	Wattage Per Shroud	Heater Voltage	Ref. Drawing Number	Shroud Part Number
7.63	14.5	12.95	270	0	0	550	10.63	CBH13713	7200	230	5	ASJ00373
7.63	15	12.95	270	0	0	550	10.63	CBH13713	7200	230	5	ASJ00358
7.63	18	12.95	270	0	0	550	10.63	CBH13712	9600	230	5	ASJ00357
7.63	21.25	13.06	270	90	90	550	10.75	CBH13364	7500	240-3PH	8	ASJ00314
8	20	13.81	270	90	0	550	11.5	CBH13571	12400	240	7	ASJ00330
8	22.5	14.06	270	90	0	550	11.75	CBH13677	11000	480	7	ASJ00347
8.25	12.5	14.06	270	0	180	550	11.75	CBH14072	5500	460-3PH	6	ASJ00390
8.25	14.5	14.06	270	0	180	550	11.75	CBH14071	7000	460-3PH	6	ASJ00391
8.5	18	14.56	270	90	90	1200	12.25	CBH12944	10800	240-3PH	8	ASJ00285
9.25	23.375	15.06	180	0	0	1200	12.75	CBH13562	15000	480-3PH	1	ASJ00327
9.31	23.25	15.2	270	0	0	(2) 550	12.88	CBH12703	15000	230-3PH	5	ASJ00264
9.5	12.5	14.81	270	0	0	485	12.5	CBH13699	8500	240	5	ASJ00353
9.5	19.5	15.56	180	0	0	1200	13.25	CBH14175	16000	240	1	ASJ00402
9.5	24	14.81	270	0	0	1200	12.5	CBH13698	15900	240-3PH	5	ASJ00354
9.5	24	14.81	270	0	0	(2) 459	12.5	CBH13327	16500	240-3PH	5	ASJ00308
9.5	24.5	15.31	180	0	90	(2) 550	12.5	CBH11891	14600	240-3PH	3	ASJ00205
9.5	24.875	15.31	270	0	0	(2) 550	13	CBH14352	20000	240 -3PH	5	ASJ00429
9.5	27	15.56	270	90	90	(2) 1200	13.25	CBH13123	20000	240-3PH	8	ASJ00289
9.5	27.38	15.56	180	0	0	(2) 550	13.25	CBH13389	2400	240	1	ASJ00317
9.5	27.75	15.56	180	0	0	(2) 550	13.25	CBH13922	20000	480-3PH	1	ASJ00375
9.75	16.5	14	270	0	0	550	13.25	CBH14126	12600	240	5	ASJ00399
9.75	19	15.81	270	0	0	1200	13.5	CBH14300	13500	480	5	ASJ00415
9.75	23.375	15.56	180	0	0	1200	13.25	CBH14419	15000	480	1	ASJ00435
9.75	24	14	270	0	0	(2) 550	13.25	CBH14125	18370	240	5	ASJ00398
9.75	24	15.31	180	0	0	1200	13	(2)CBH13801	7000	240-3PH	1	ASJ00370
9.76	12.5	15.82	270	0	0	550	13.5	CBH13799	10000	240-3PH	5	ASJ00365
9.88	15.5	16.06	270	90	0	550	13.38	CBH13319	9550	240-3PH	7	ASJ00307
9.88	24.5	16.06	270	90	0	(2) 550	13.38	CBH13318	14600	240-3PH	7	ASJ00306
9.94	18	16.31	180	0	90	1200	13.44	CBH12495	16000	440	3	ASJ00249
9.94	23	16.31	180	0	90	1200	13.44	CBH12496	18000	440	3	ASJ00250
10	28	16.06	270	90	90	(2) 550	13.75	CBH14193	11000	240	8	ASJ00404
10.75	7.5	16.56	270	0	0	485	14.25	CBH14203	7500	480	5	ASJ00406
12.5	34.5	18.81	180	0	0	(2) 1200	16.5	(2)CBH13888	35000	460-3PH	1	ASJ00374
13.5	12	19.56	180	0	90	550	17.25	CBH13359	9000	460	3	ASJ00313
13.5	17.5	19.56	180	0	90	550	17.25	(2)CBH13358	14000	460	3	ASJ00312
13.5	23	19.56	180	0	90	(2) 550	17.25	(2)CBH13359	18000	460	3	ASJ00311



Note: Reference Drawings can be found on page 3-32.

Ordering Information

If you cannot find an existing shroud design that meets your requirements precisely, please use the ordering form on page 3-36 to process your quote request.

Tempco's engineering professionals will custom design a shroud system to meet your extruder process challenges.

Existing Cool TO-THE Touch Extruder Heat/Cool System Reference Shroud Drawings

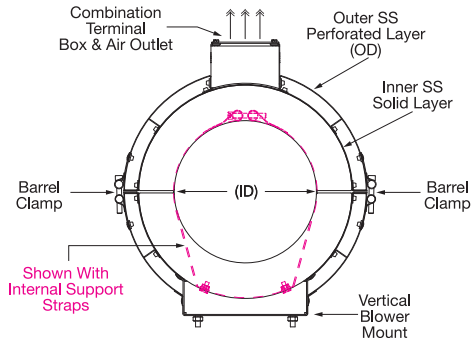

Drawing 1

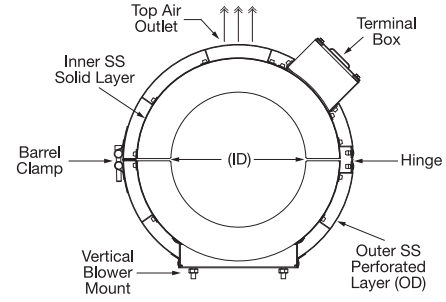

Drawing 2

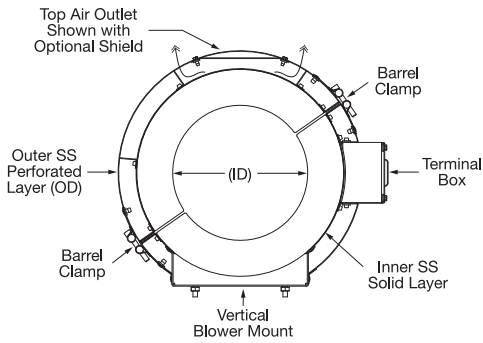

Drawing 3

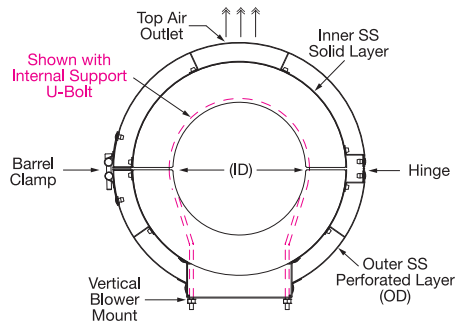

Drawing 4

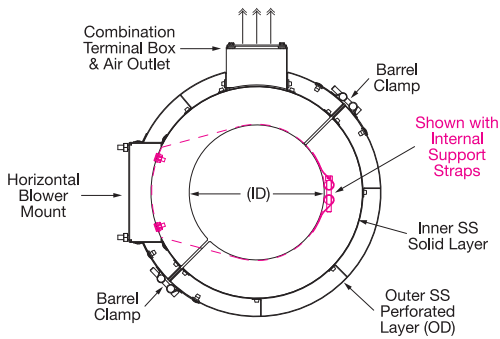

Drawing 5

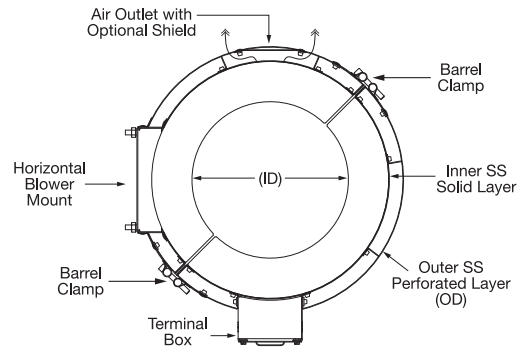

Drawing 6

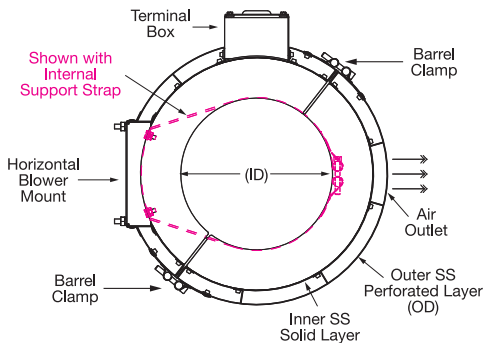

Drawing 7

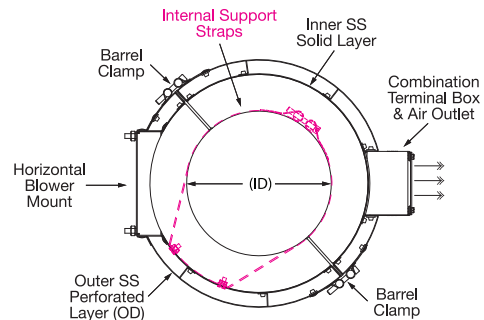

Drawing 8

Multi-Versal Extruder Heat/Cool System

Tempco's Multi-Versal extruder heat/cool systems are designed for efficient heating and cooling. The shroud systems can be used with many styles of band heaters. Due to the single layer design, the Multi-Versal shroud system has a low profile OD.

The reflective interior of the shroud decreases the heat-up cycle, reducing energy consumption. The unrestricted blower port directs inlet air to the hottest part of the heater and distributes it evenly over the entire cross section of the zone.

2 – Multi-Versal Construction

Multi-Versal Extruder

**Solid, Stainless Steel
Single Layer Shroud**

Usage Requirements

A highly adaptable single layer shroud, suited for retrofit and/or new applications regardless of the type of barrel band heater being used.

Multi-Versal Construction Details

Single Layer Shroud

- * *Solid Stainless Steel Layer – radiation shield that directs the cooling air flow over the heater*

Shroud Assembly Features

- * *Two Mounting Styles are available:*
 - ➔ *Hinge with Barrel Clamps – designed for ease of installation*
 - ➔ *Two Individual Halves with Barrel Clamps (Two-Piece) – used where installation space is tight or mounting is difficult*
- * *Internal Support Straps or Support U-Bolt on blower mount half of shroud permits shroud to be opened for servicing without removing unit from barrel*
- * *Anti-Rotate Tabs – used only with Finned Cast-In Heaters to prevent shroud from radial and axial movement around the barrel*
 - ➔ *Tabs are cast as part of the heater and may require a Terminal Box*
- * *Blower Options – See page 3-41 through 3-43 for Complete Details*
 - ➔ *Single or Dual Tempco Recommended Blowers available from 148 CFM up to 1210 CFM at 115V or 230V, or 480V 3-Phase*
 - ➔ *Customer Specified blower*
 - ➔ *Blower not required for Heat-Only Shrouds*
- * *Blower Location*
 - ➔ *Horizontal or Vertical Orientation*
 - ➔ *Extension Housings Available*
- * *Standard separate top Screened Air Outlet*
- * *Optional Screened Air Outlet Features Include:*
 - ➔ *Air Outlet combined with Terminal Box*
 - ➔ *Alternate Radial Air Outlet locations available*
- * *Shroud Air-Inlet Baffle Optional*
- * *Vent Hole(s) Optional*



Multi-Versal shown with horizontally mounted blower & vertical combination terminal box & air outlet

Heater Type and Components

- * *Recommended Heater Types – Finned Cast-In Heaters with standard 1/4" gap between heater halves, Ceramic Band and Maxiband Heaters*
- * *Power Input Terminal Box with 7/8" dia. K.O. for 1/2" conduit:*
 - ➔ *Standard 10-32 stud termination with ceramic or mica insulator*
 - ➔ *With Louvered Cover – used when terminal box is separate from air-outlet*
 - ➔ *Stainless Steel Screen – used when terminal box is combined with air outlet*
- * *Power Input through Blower Mount – input wiring through knockouts in blower mount eliminates terminal box and facilitates ease of heater service*

Sensing and Controlling

- * *Existing Zone Control Probe – Shroud System can be designed per customer specifications*
- * *Tempco supplied Zone Control Probe*
- * *Tempco customized Power Control Panel designed to complete Your Thermal Loop System*

Ordering Information

See Page 3-36 for complete Ordering Information.

(800) 323-6859 • Email: sales@tempco.com



Multi-Versal Extruder Heat/Cool System

Horizontal and Vertical Blower Motor Mount Design Specifications

The following partial listings are part numbers and specifications for shroud designs that Tempco has engineered and manufactured. Each item listed below can be modified to fit customer requirements. Zone Control Probes are placed per customer specifications. See page 3-33 for complete details.

Barrel OD (Shroud ID)	Shroud Width	Shroud OD (in)	Blower Location (in)	Air Outlet Location (°)	Terminal Box Location (°)	Blower CFM (°)	Maximum Heater OD	Heater Part Number (in)	Wattage Per Shroud	Heater Voltage	Ref. Drawing Number	Shroud Part Number
5.5	13	9.5	180	0	0	273	8.75	CBH07945	5600	600	3	ASJ00041
5.9	16	10.97	270	0	0	550	9.875	CBH14346	8000	240-3PH	5	ASJ00427
6.25	13.5	10.82	180	0	0	550	10	BCH06668	6000	240	3	ASJ00292
6.25	14	10.5	180	0	0	550	9.75	CBH14356	6800	240	3	ASJ00431
6.25	18.5	10.25	180	0	0	550	9.5	CBH11500	8800	460	3	ASJ00177
6.5	13	10.32	180	0	0	358	9.5	CBH13473	7500	240	3	ASJ00321
6.5	15.5	10.75	180	0	0	358	10	CBH11428	8000	575	3	ASJ00167
6.625	18.5	10.625	180	0	0	550	9.875	CBH07947	8800	460	3	ASJ00042
6.63	17.5	11.2	270	0	0	485	10.38	CBH14069	9250	480	5	ASJ00389
7.5	14.25	11.25	180	0	0	550	10.5	CBH13306	7000	240	3	ASJ00304
7.5	18	11.25	180	0	0	550	10.5	CBH13305	10600	240	3	ASJ00303
7.5	20.5	11.75	90	270	270	797	11	(2)BCH07244	6000	480	1	ASJ00380
7.5	29	11.25	180		0	(2) 550	10.5	(2)CBH13307	16200	240	3	ASJ00302
8.5	10.25	12.5	270	0	0	485	11.75	BCH07114	2200	240	5	ASJ00363
8.5	15.25	13	90	0	NONE	1200	12.25	CBH13467	6000	230	2	ASJ00320
9.5	27.5	14	180	0	0	(2) 732	13.25	(2)CBH13149	12000	230	3	ASJ00290
9.5	27.75	14	180	0	0	(2) 550	13.25	CBH14088	24000	480-3PH	3	ASJ00393
9.75	11.5	13.75	180	0	0	358	13	CBH09965	9000	230	3	ASJ00078
9.75	11.5	13.75	180	0	NONE	358	13	CBH09965	9000	230	4	ASJ00131
9.75	19.5	15	180	0	NONE	1200	14.25	CBH12313	12600	240	4	ASJ00076
9.75	23.5	13.5	180	0	0	(2) 485	12.75	CBH10719	16000	240	3	ASJ00112
9.88	22	14.13	180	0	NONE	1200	13.38	CBH13711	10500	220	4	ASJ00355
10.75	11	15	180	0	0	550	14.25	CBH14235	8800	230	3	ASJ00408
11.5	15.38	16	180	0	0	797	15.25	CBH13295	11000	460	3	ASJ00301
12.25	17.75	16.75	180	0	0	1200	16	CBH13347	16500	230-3PH	3	ASJ00310

Ordering Information

If you cannot find an existing shroud design that meets your requirements precisely, please use the ordering form on page 3-36 to process your quote request.

Tempco's engineering professionals will custom design a shroud system to meet your extruder process challenges.

Existing Multi-Versal Extruder Heat/Cool System Reference Shroud Drawings

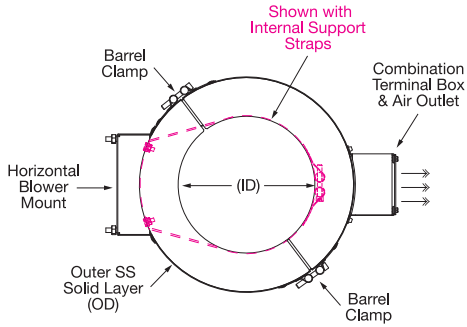

Drawing 1

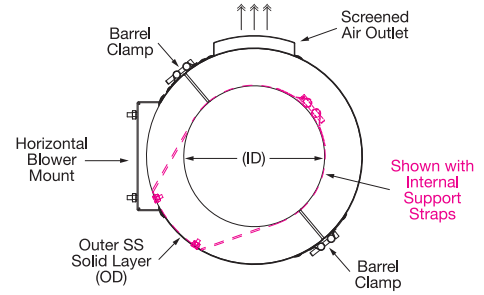

Drawing 2

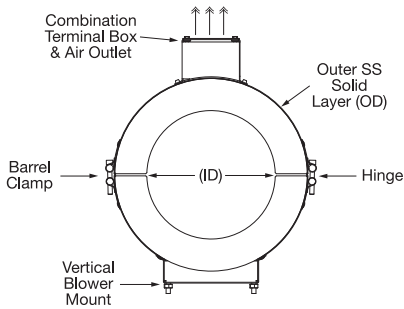

Drawing 3

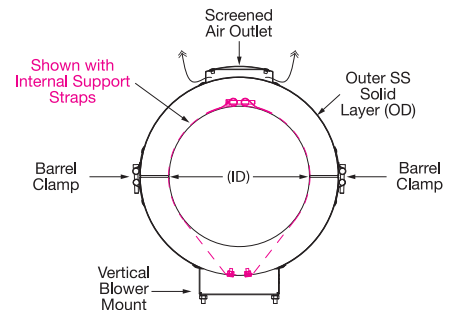

Drawing 4

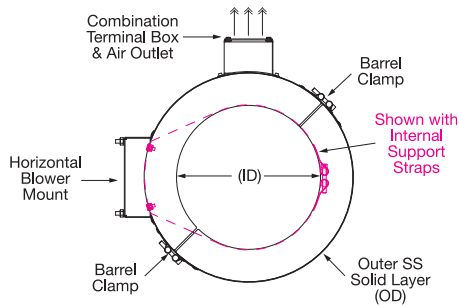

Drawing 5

Cast-In Heaters



Stainless Steel Shroud Systems

Made-To-Order Quote Request Form — Copy and Fax Us (630-350-0232) Your Requirements

Customer Information

Name: _____ Company: _____ City: _____ State: _____
Phone: _____ Fax: _____ Email: _____
Extruder Barrel Manufacturer: _____ Model Number: _____
Resin Type: _____ Process Temperature: _____

When submitting this form, please be sure to include an extruder barrel sketch or drawing that includes the following:

- * Extruder Barrel Support(s)
- * Number of Heating Zones
- * Vent Location(s)
- * Zone Probe Location(s)
- * Input Feed Location
- * Pressure Tap Location(s)
- * Zone Length(s)
- * Additional Restriction(s)

Note: To assist Tempco in designing a shroud system, please provide digital images (in .jpg format) of the extruder barrel.

Shroud Specifications

(For replacement of existing Tempco Shroud(s), please contact your Tempco Factory or Sales Representative.)

Shroud Style: Cool TO-THE Touch™ Multi-Versal Quantity Required: _____

Shroud Dimensions

Shroud Width / Zone Length: _____ Extruder Barrel OD / Shroud ID: _____
Maximum Shroud OD: _____ (determined by Engineering unless specified by customer)
Existing Heater OD (including terminations): _____ (determined by Engineering when new Tempco Heater is purchased)
Internal Shroud Support Required: Yes No

Shroud Components and Component Locations

Component Options (see pages 3-29 or 3-33 for shroud component details)

1. Blower Mount:
 Horizontal Vertical
2. Air Outlet:
 Separate from Terminal Box Combined w/ Terminal Box
3. Terminal Box:
 None Louvered (Separated from Air Outlet)
 Screened (Combined with Air Outlet)
4. Clamping Method at Shroud Opening:
 Barrel Clamps with Hinge Barrel Clamps (no Hinge)
 Adjustable Clamps with Hinge Adjustable Clamps (no Hinge)
5. Zone T/C Probe(s) - Customer Specified:
Quantity: _____ Clearance Hole Diameter(s): _____

Please indicate Component Radial Locations:

- 1 _____
Blower Mount
- 2 _____
Air outlet
- 3 _____
Terminal Box
- 4 _____
Clamps
- 5 _____
Hinge (if applicable)
- 5 _____
Zone T/C Probe(s)

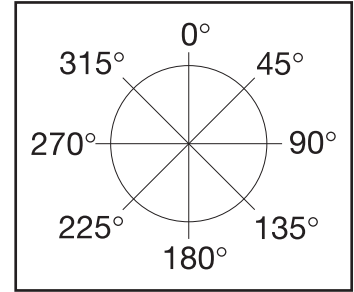

Blower Specifications

 (see page 3-43 for standard Tempco blowers & configuration details)

Configuration: Single Dual Customer Supplied (*see below)
 Stock Tempco Blower (Engineering will determine specifications if none specified)
P/N: _____ or CFM: _____ Volts: _____ Operating Frequency: _____ Hz
Optional Blower Extension: Horizontal Vertical Custom (Consult Tempco.)
 *Customer Supplied Blower (Please attach mounting information when submitting this form.)
Manufacturer: _____ P/N: _____ CFM: _____ Volts: _____ Operating Frequency: _____ Hz

Heater Specifications

Existing Tempco Heater: P/N: _____ Replace Existing Heater Cover Existing Heater

If purchasing new Tempco Heater(s), please provide the following information if known:

Type and Quantity Required:
Qty. Cast-In(s) _____ Qty. Ceramic Bands _____ Qty. Maxibands _____
Inner Diameter: _____ Width(s): _____ Wattage per Shroud: _____ Voltage: _____

⚠ WARNING: Cancer and Reproductive Harm - www.P65Warnings.ca.gov.

Arctic Cast® Extruder Heat/Cool System

Tempco's Arctic Cast Shroud System was our pioneer shroud design for the air-cooling of extruders. The cooling efficiency of the Arctic Cast shroud system meets or exceeds that of water-cooled systems when used with our field proven high-capacity blowers.

The Arctic Cast shroud features a vented 1/4" thick cast aluminum layer for durability. The cast-in heaters are designed with a large fin surface area to maximize cooling efficiency. The blower port directs inlet air to the hottest part of the heater, distributing it evenly over the entire cross section of the zone.

3 – Arctic Cast Construction

Arctic Cast Extruder

Single Layer Shroud – Vented Cast Aluminum layer bolted directly onto Tempco's Specially Designed Finned Cast-In Aluminum Band Heater

Usage Requirements

This rugged shroud design is recommended for installations where the shroud system could be exposed to physical damage, such as instances where the extruder barrel is low to the ground. It is suited to work with Tempco's Specially Designed Finned Cast-In Aluminum Heater and cannot be used on any existing finned cast-in heaters.

Arctic Cast Construction Details

Single Layer Shroud

- * Vented 1/4" thick Cast Aluminum layer – directs the cooling air flow over the heater

Shroud Assembly Features

- * Two Individual Halves bolted together (Two-Piece) and clamped around finned cast heater
- * Blower Options – See Pages 3-41 through 3-43 for complete details
 - Single or Dual Tempco Recommended Blowers available from 148 CFM up to 1210 CFM at 115V or 230V, or 480V 3-Phase
 - Customer Specified blower
- * Blower Location
 - Vertical Orientation – at the bottom of the shroud
 - Custom location achieved only by rotating entire shroud system
- * Standard top Air Outlet
 - Custom location achieved only by rotating entire shroud system
- * Shroud Air-Inlet Baffle with built-in air deflector that breaks up incoming airflow, distributing it across the cast-in heater(s)



Arctic Cast shown with Vertical Mount Option

Heater Type and Components

- * Recommended Heater Types – Tempco Finned Cast-In Heaters with standard 1/4" gap between heater halves and bolt and nut clamping
- * Heater Strap Clamping is available
- * Power Input with Standard 10-32 stud termination with ceramic or mica insulator
 - Bus Wiring between halves is optional

Sensing and Controlling

- * Existing Zone Control Probe – Shroud System can be designed per customer specifications
- * Tempco supplied Zone Control Probe
- * Tempco customized Power Control Panel designed to complete Your Thermal Loop System

Ordering Information

See Page 3-40 for complete Ordering Information.

Cast-In Heaters



Arctic Cast® Shroud System

Standard (Non-Stock) Arctic-Cast® Cast-In Heaters (319 Aluminum) and Shrouds

Heater I.D. in	Heater O.D. in	Heater Length in	Watts Each Half	Volts Each Half	Phase	Termination Type	Clamping Type	Cast-In Heater Part Number	Shroud Dimensions				Shroud Style	Shroud Part Number
									I.D. in	Length "L" in	"G" in	"H" in		
3	7	5.5	650	240	1	R	Bolt	CBH13085	7	4.375	3.7	3.22	A	ASF01218
3	7	7	1000	240	1	E	Bolt	CBH13537	7	7	1.5	4.125	A	ASF01221
3.75	7.75	13	2300	240	1	E	Bolt	CBH09406	7.75	13	6	5	A	ASF01160
4.25	7.5	13	2910	230	3	E	Strap	CBH08563	7.5	13	3.5	2.5	B	ASF01138
4.5	9	10.75	1620	230	1	E	Strap	CBH02937	9	10.75	5	6	A	ASF01006
4.5	7.75	12.25	1500	230	1	E	Strap	CBH05676	7.75	12.25	4.406	4.375	C	ASF01052
4.5	8.25	12.5	2500	240	1	C4	Bolt	CBH14435	8.25	12.5	6	5	A	ASF01232
5	9	12.438	2000	230	1	E	Strap	CBH05677	9	12.438	4.406	4.375	C	ASF01053
5.25	8.5	13.5	3750	190	3	E	Strap	CBH08561	8.5	13.5	3.5	2.5	B	ASF01136
5.5	10	11	2100	230	1	E	Strap	CBH02803	10	11	5	6	A	ASF01002
5.5	10	15.5	4000	240	1	E	Bolt	CBH10185	10	15.5	6.25	7.25	A	ASF01183
5.5	9.5	18	1200	277	1	E	Strap	CBH10258	9.5	18	8.813	2.188	A	ASF01186
6	10	11	3300	230	1	S	Strap	CBH04243	10	11	5	6	A	ASF01002
6	10	18	5000	240	1	E	Bolt	CBH09383	10	18	6.25	7.25	A	ASF01158
6	10	16	4000	240	1	E	Bolt	CBH11316	10	16	6.25	7.25	A	ASF01199
6	10	10	3750	240	3	T	Bolt	CBH12072	10	10	4.875	4.375	A	ASF01211
6	9.75	18	5000	240	1	S	Bolt	CBH14604	9.75	18	7.75	4	A	ASF01236
6.25	10.5	15	4800	230	1	E	Strap	CBH07349	10.5	15	4.875	4.375	A	ASF01095
6.5	11	17.5	3600	230	1	E	Strap	CBH02802	11	17.5	5	6	A	ASF01003
6.5	10	10.75	2280	240	1	E	Strap	CBH06509	10	10.75	4.875	2.375	A	ASF01076
6.5	11	17.5	3600	230	1	E	Strap	CBH07372	11	17.5	4.625	5.625	A	ASF01098
6.5	10.5	13	4000	240	1	E	Strap	CBH09413	10.5	13	4.875	4.375	A	ASF01161
6.5	10.5	16	4000	240	3	E	Strap	CBH09414	10.5	16	4.875	4.375	A	ASF01162
6.635	11	17.5	4360	240	1	S	Bolt	CBH06070	11	17.5	4.86	4.37	A	ASF01008
7	11	13.5	2400	230	1	E	Strap	CBH05871	11	13.5	4.406	4.375	C	ASF01057
7	10.25	18	6000	230	3	E	Strap	CBH08425	10.25	18	4.438	4.375	C	ASF01134
7	11	17.5	6000	240	1	S	Strap	CBH08635	11	17.5	4.375	4.875	A	ASF01143
7	11	19	6000	240	3	E	Bolt	CBH09362	11	19	6.5	7.25	A	ASF01157
7.5	12	18	3500	230	1	E	Strap	CBH05574	12	18	5	5	A	ASF01048
7.5	12	17	3000	480	1	E	Strap	CBH06561	12	17	3.5	3.5	A	ASF01035
7.5	11.5	18	6000	240	3	E	Strap	CBH08685	11.5	18	4.875	2.375	A	ASF01066
7.5	10.75	19	7500	190	3	C4	Bolt	CBH14386	10.75	19	8.75	4	A	ASF01227
7.5	10.75	19	7500	240	3	C4	Bolt	CBH15013	10.75	19	8.75	4	A	ASF01227
8	12	14	3250	230	1	E	Strap	CBH03738	12	14	5	5	A	ASF01013
8	12	18	5000	480	3	C4	Bolt	CBH06432	12	18	3.875	3.875	A	ASF01069
8	11.25	16	2750	230	1	E	Bolt	CBH13777	11.25	16	8.813	4.375	A	ASF01224
8.25	12.25	13	3850	230	1	S	Strap	CBH03994	12.25	13	5	4.875	A	ASF01019
8.5	11.75	10	4425	230	3	E	Strap	CBH08562	11.75	10	4.406	4.375	C	ASF01137
8.5	12	17	5900	240	1	E	Strap	CBH10213	12	17	6	5	A	ASF01185
9	13	18.75	5000	230	1	E	Strap	CBH08278	13	18.75	4.375	5.5	C	ASF01126
9.5	13.25	13	3000	240	0	E	Bolt	CBH13600	13.25	13	4.96	5.94	A	ASF01222
9.75	13.75	19	7500	480	3	S	Bolt	CBH05684	13.75	19	3.875	3.875	A	ASF01054
9.75	13.75	22	6000	230	1	E	Bolt	CBH08024	13.75	22	6.452	6.452	A	ASF01119
9.75	13.75	19	6000	230	1	E	Bolt	CBH08025	13.75	19	5	6	B	ASF01120
9.75	13.75	22	11000	200	3	F	Bolt	CBH10086	13.75	22	6.452	6.452	A	ASF01181
10	9	12	6480	230	3	S	Strap	CBH05102	9	12	5	6	A	ASF01006
10	13.5	24	11000	600	3	RIA	Bolt	CBH07294	13.5	24	6.25	6.25	A	ASF01094
10	14	12	6480	230	1	E	Strap	CBH07404	14	25	6	5	B	ASF01101
10	13.25	12	6480	230	3	E	Strap	CBH08424	13.25	12	4.406	4.375	C	ASF01129
10	14	12	6480	480	1	E	Strap	CBH14775	14	12	6	5	B	ASF01101
12	16	14.5	4250	240	3	E	Strap	CBH09876	16	14.5	5.504	5.504	A	ASF01172
12	16	23	6500	480	1	E	Bolt	CBH11446	16	23	6.5	4	C	ASF01203
13	16.25	13.75	6750	190	3	E	Strap	CBH09878	16.25	13.75	4.406	4.375	C	ASF01173

The typical Arctic Cast System consists of:

- A Cast-In Aluminum Finned Band Heater
- A Cast Aluminum Shroud
- An appropriately rated Forced Air Blower



Note: For additional information on sizing and selecting Cast-In Band Heaters for your application, see page 3-39. To order an Arctic-

Page 3-37 illustrates the complete system as well as the components that make up each assembly. Envelope dimensions for the shrouds shown on page 3-39 are also provided. Pages 3-41 through 3-43 display different forced air blower styles and specifications.

Cast system not shown in our Standard Sizes and Ratings, consult Tempco or send us your specifications and/or drawing.

Selection of Arctic Cast® Shroud Design Styles

Shroud Style A

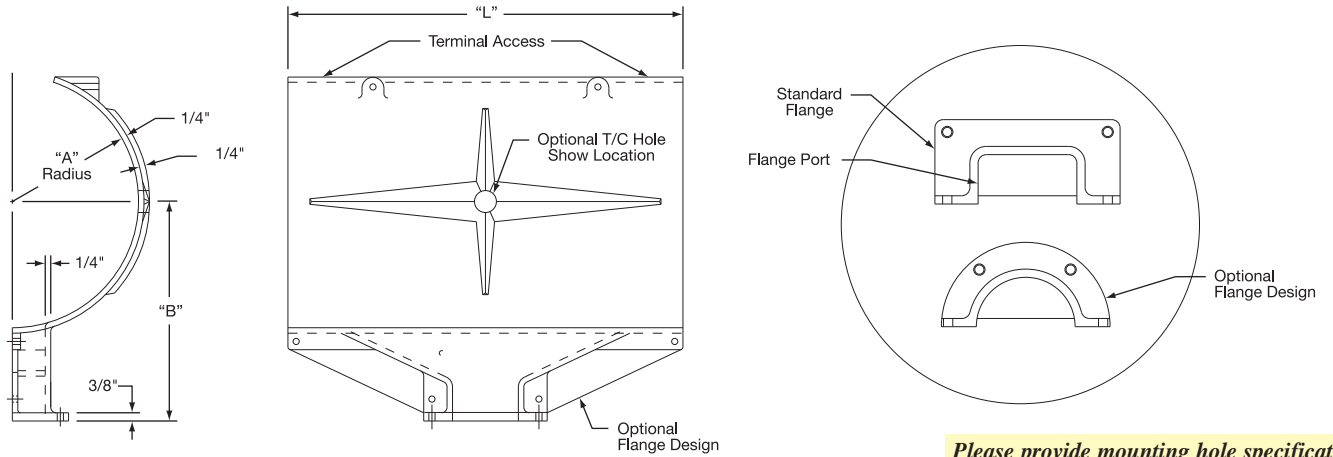

Please provide mounting hole specifications if using other than Tempco standard.

Shroud Style B

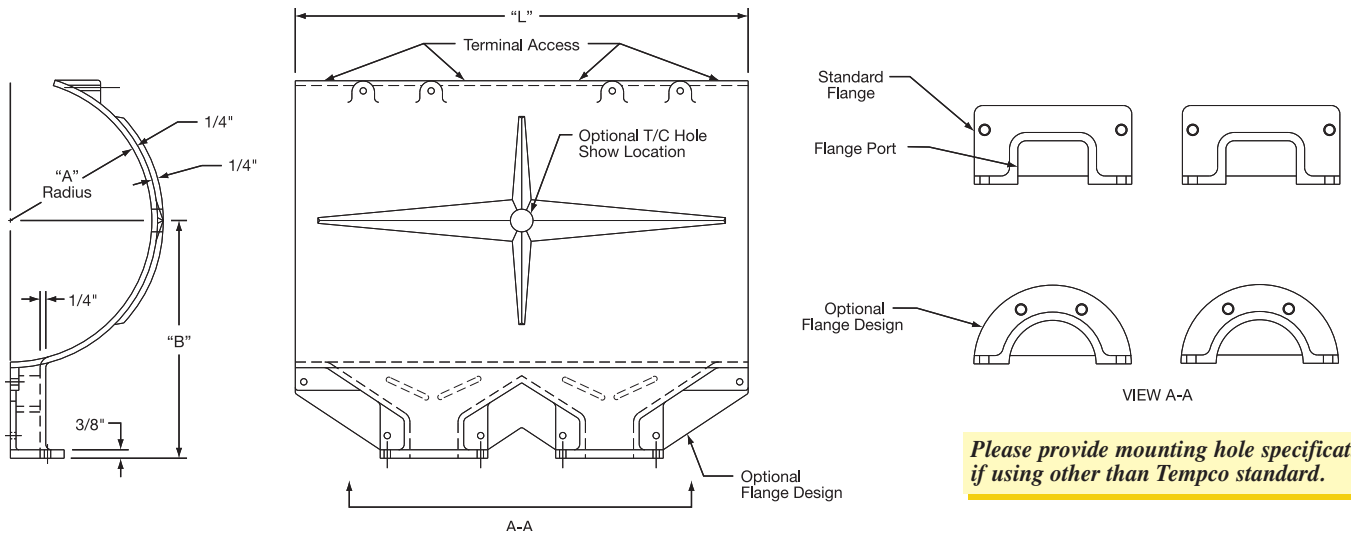

Please provide mounting hole specifications if using other than Tempco standard.

Shroud Style C

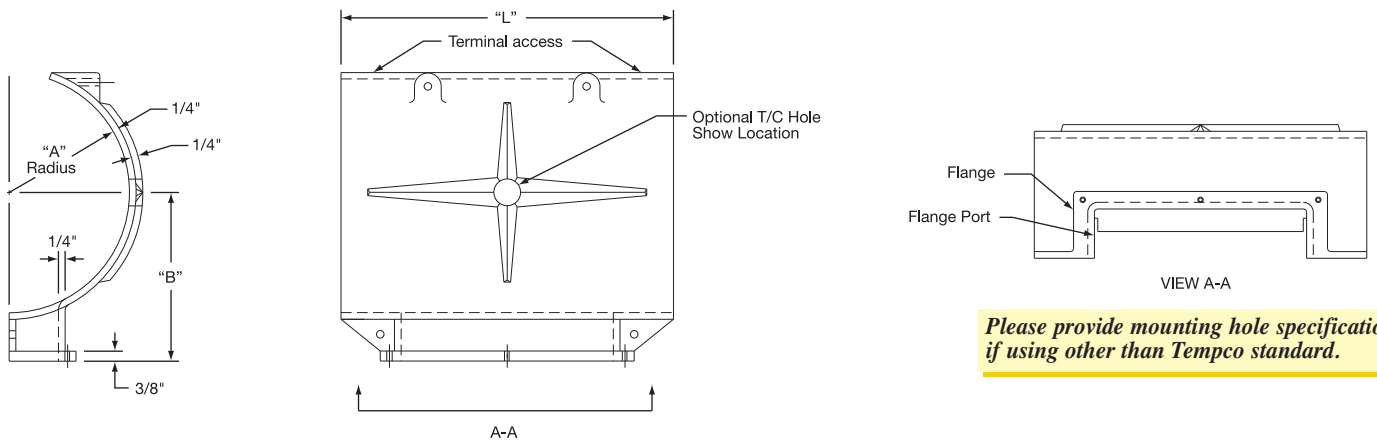

Please provide mounting hole specifications if using other than Tempco standard.

Cast-In Heaters



Arctic Cast® Shroud System

Made-To-Order Quote Request Form — Copy and Fax Us (630-350-0232) Your Requirements

Customer Information

Name: _____ Company: _____ City: _____ State: _____
 Phone: _____ Fax: _____ Email: _____
 Extruder Barrel Manufacturer: _____ Model Number: _____
 Resin Type: _____ Process Temperature: _____

When submitting this form, please be sure to include an extruder barrel sketch or drawing that includes the following:

- * Extruder Barrel Support(s)
- * Number of Heating Zones
- * Vent Location(s)
- * Zone Probe Location(s)
- * Input Feed Location
- * Pressure Tap Location(s)
- * Zone Length(s)
- * Additional Restriction(s)

Note: To assist Tempco in designing a shroud system, please provide digital images (in .jpg format) of the extruder barrel.

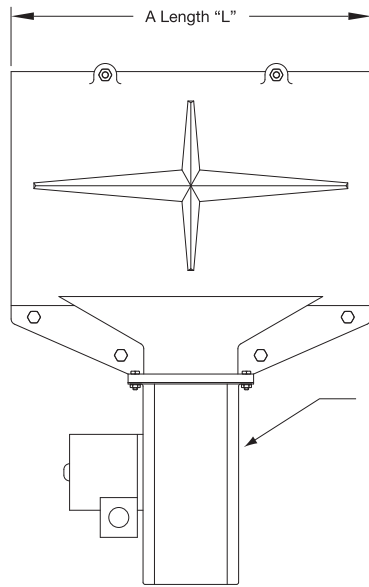
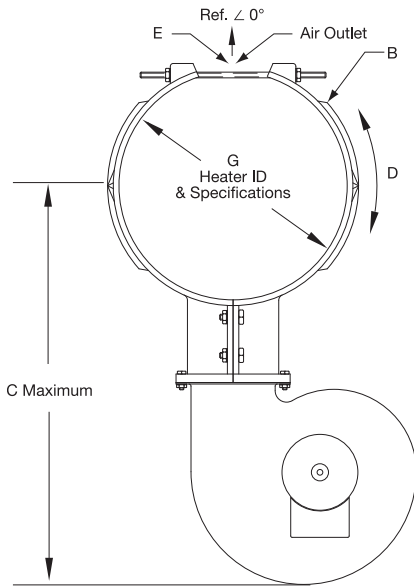

Drawing Reference Angle

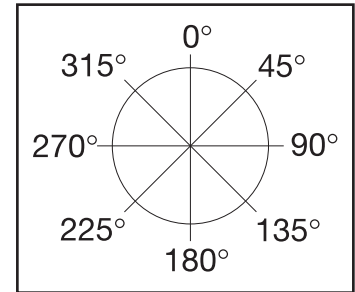

Shroud Specifications

(For replacement of existing Tempco Shroud(s), please contact your Tempco Factory or Sales Representative.)

- A. Shroud Width / Zone Length "L": _____
 B. Maximum Shroud OD: _____ (determined by Engineering unless specified by customer)

Shroud Component Specifications

- C. Maximum Blower Clearance: _____
 D. Standard Shroud Assembly Orientation Shown: Air Outlet at 0°, Blower at 180°
 For alternate orientations, rotate shroud and heater assembly on extruder barrel.
 E. Zone T/C Probe(s): Quantity: _____ Clearance Hole Diameter: _____
 Location: Centered at Top (standard) Custom: _____ (Indicate Clockwise from Drawing Reference Angle)

Blower Specifications

- F. Configuration: Single Dual Customer Supplied (*see below)
 Stock Tempco Blower (Engineering will determine specifications if none specified)
 P/N: _____ or CFM: _____ Volts: _____ Operating Frequency: _____ Hz
 Optional Inlet Guard (available for most stock blowers)
 Optional Blower Extension: Horizontal Vertical Custom (Consult Tempco.)
 Mounting Dimensions: Length _____ Width _____
 *Customer Supplied Blower (Please attach mounting information when submitting this form.)
 Manufacturer: _____ P/N: _____ CFM: _____ Volts: _____ Operating Frequency: _____ Hz

Heater Specifications

- G. Extruder Barrel OD/Heater ID: _____ Wattage per Half: _____ Voltage per Half: _____

⚠ WARNING: Cancer and Reproductive Harm - www.P65Warnings.ca.gov.

Forced-Air Blowers for Air-Cooled Heating Systems

A variety of sizes and styles of forced-air centrifugal blowers are used on Tempco's air-cooled extrusion systems. Tempco Forced-Air Blowers are available in a large range of CFM ratings to fit any new or existing application. All blowers include air inlet guards for your safety.



Standard Single Phase Centrifugal Blowers

Tempco standard blowers feature corrosion protected sheet metal housings and impeller wheels. The quiet operation and quick response coupled with high volume unrestricted output results in a field-proven efficient cooling means for extrusion processes. Standard blowers are readily available for single phase 115V or 230V and represent the shortest delivery times.

Single Port Blowers

Part Number	"D"	"F"	"G"	"H"	"N"	"P"	"R"	"S"	Outlet "L" x "W"	CFM	Volts	Full Load Amps	Replacement Guard PN
MTR-102-101	3.50	4.60	3.96	2.88	6.91	6.26	5.32	5.70	2.18 x 3.25	146	115	0.75	GRD-101-102
MTR-102-102	5.00	5.51	4.86	4.37	8.21	7.56	8.88	9.90	3.62 x 4.13	273	115	0.77	GRD-101-103
MTR-102-103	5.00	5.51	4.86	4.37	8.21	7.56	8.88	9.90	3.62 x 4.13	273	230	0.43	GRD-101-103
MTR-102-104	5.63	5.08	4.50	5.00	8.09	7.48	10.44	11.16	4.25 x 3.81	358	230	0.54	GRD-101-104
MTR-102-105	5.63	5.08	4.50	5.00	8.09	7.48	10.40	11.20	4.25 x 3.81	485	115	1.35	GRD-101-104
MTR-102-106	5.63	6.63	6.00	5.00	9.59	8.92	10.42	11.16	4.25 x 5.25	550	115	2.05	GRD-101-104
MTR-102-107	5.63	6.63	6.00	5.00	9.59	8.92	10.40	11.20	4.25 x 5.25	550	230	0.98	GRD-101-104
MTR-102-108	6.37	8.75	8.00	5.00	11.56	11.56	13.13	14.88	5.56 x 7.19	1202	115/230	7.30/3.70	GRD-101-108
MTR-102-113	6.37	7.75	7.00	5.00	10.31	10.31	13.13	14.88	5.56 x 6.19	794	115/230	2.75/1.45	GRD-101-108

NOTE: See Blower Drawing 1 on page 3-43

Single Port Large Volume Blowers

Part Number	"D"	"F"	"G"	"H"	"N"	"R"	"S"	Outlet "L" x "W"	CFM	Volts	Full Load Amps	Replacement Guard PN
MTR-102-109	5.00	9.69	4.41	4.38	9.25	8.81	9.88	3.69 x 8.06	458	115	1.28	GRD-101-103
MTR-102-110	5.00	9.69	4.41	4.38	9.45	8.81	9.88	3.69 x 8.06	458	230	0.65	GRD-101-103
MTR-102-111	5.63	9.31	4.38	5.00	10.75	10.31	11.13	4.19 x 8.69	797/549	115	3.20/2.20	GRD-101-104

NOTE: See Blower Drawing 2 on page 3-43

Double Port Blowers

Part Number	"D"	"F"	"G"	"H"	"M"	"N"	"P"	"R"	"S"	Outlet "L" x "W"	CFM	Volts	Full Load Amps	Replacement Guard PN
MTR-102-112	4.75	4.75	4.13	1.47	7.50	12.20	10.90	8.06	7.89	2.94 x 3.31	312	115	0.77	GRD-101-103

NOTE: See Blower Drawing 3 on page 3-43



Low-Profile Single Phase Centrifugal Blowers

Tempco low-profile 115/230V single phase blowers offer a narrower footprint than the standard blowers. The motor is integrated with the impeller so that the motor housing protrudes only slightly from the blower housing. Low-profile blowers are made of die-cast aluminum and galvanized sheet steel and are perfect for applications where space is a concern.

Single Port Blowers

Part Number	"D"	"F"	"G"	"H"	"N"	"P"	"R"	"S"	Outlet "L" x "W"	CFM	Volts	Full Load Amps	Replacement Guard PN	Replacement Capacitor PN
MTR-103-101	2.68	3.00	2.60	2.28	3.44	3.15	4.65	4.50	2.19 x 1.66	56	115	0.24	GRD-101-101	TEC-114-101
MTR-103-102	2.68	3.00	2.60	2.28	3.44	3.15	4.65	4.50	2.19 x 1.66	56	230	0.13	GRD-101-101	TEC-114-102
MTR-103-103	4.72	5.12	4.53	4.13	5.12	3.94	8.90	9.72	3.62 x 3.70	283	230	0.89	GRD-101-103	TEC-114-101
MTR-103-104	7.40	6.96	5.00	6.00	5.27	4.96	11.28	14.04	4.79 x 5.27	500	230	0.78	GRD-101-106	TEC-114-101

NOTE: See Blower Drawing 1 on page 3-45

Forced-Air Blowers for Air-Cooled Heating Systems

Universal Three-Phase Centrifugal Blowers



Tempco high-end blowers use heavy duty construction for a long service life. They are available with universal three-phase motors for 50/60 HZ operation on voltages from 202 up to 530V. They meet Cenelec standards and are IP41 or IP54 rated with class B or F insulation systems. These low noise, continuous duty rated blowers operate efficiently under higher static pressure loads than our standard blowers. Optional attachments are available for transferring high temperature air up to 200-300° C and inlet filters for dusty environments.

Single Port Blowers — 3-Phase 60 Hz (202-306V 3-Ph. Delta, 350-530V 3-Ph. Y)

Part Number	"D"	"F"	"G"	"H"	"N"	"P"	"R"	"S"	Outlet "L" x "W"	CFM	Volts	Full Load Amps
MTR-104-101	3.85	4.41	3.74	3.15	9.17	8.62	7.75	3.00	2.56 x 3.11	253-300	240/480	0.51/0.29
MTR-104-102	5.11	5.51	4.72	4.33	11.85	11.06	8.81	8.97	3.54 x 3.66	459-556	240/480	1.15/0.65
MTR-104-103	5.51	5.91	5.19	4.72	13.62	13.00	9.49	10.43	3.90 x 4.29	732-853	240/480	2.30/1.35
MTR-104-104	6.14	6.61	5.94	4.96	15.02	14.25	10.51	11.73	4.41 x 4.88	1130-1200	240/480	4.00/2.30

NOTE: See Blower Drawing 1 on page 3-43

Double Port Blowers — 3-Phase 60 Hz (202-306V 3-Ph. Delta, 350-530V 3-Ph. Y)

Part Number	"D"	"F"	"G"	"H"	"M"	"N"	"P"	"R"	"S"	Outlet "L" x "W"	CFM	Volts	Full Load Amps
MTR-104-105	5.19	5.51	4.72	4.33	9.74	15.25	13.68	8.82	8.98	3.54 x 3.66	550-665	240/480	1.10/0.65

NOTE: See Blower Drawing 3 on page 3-43

Extensions for Forced-Air Blowers

Blower extensions are available for applications where space restrictions do not allow the blower to be mounted directly to the shroud assembly.



Horizontal Blower Extension allows blower to be mounted perpendicular to the shroud. A baffle inside the blower extension smoothly guides air flow into the shroud.

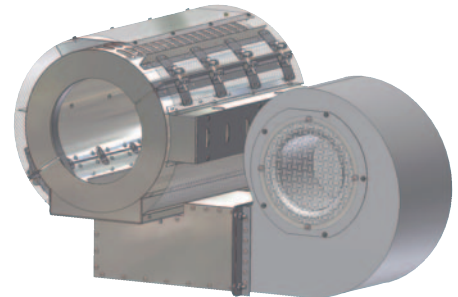

Vertical Blower Extension allows blower to be vertically offset at a distance below the shroud as specified by the customer. Especially useful in retrofit applications.



Vertical Blower Extension with 90° adapter plate allows blower to be vertically offset from the shroud. Blower can be rotated at 90° intervals relative to the extension.



Inlet Guards for Single Inlet Centrifugal Blowers

Single Port Blower: Drawing 1

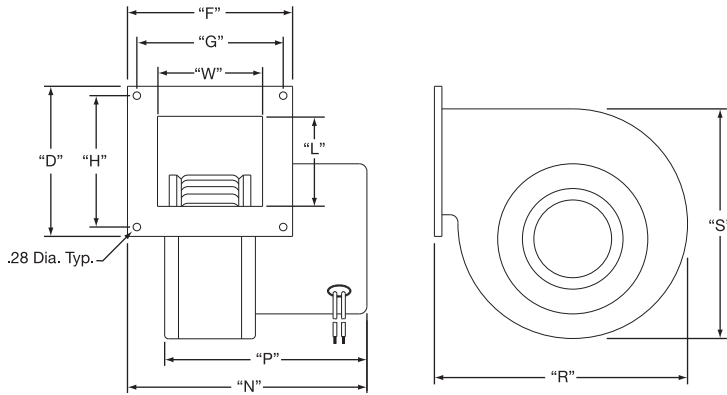

Special cast housing narrow blowers for small extruders or short barrel zone widths are available from 23 up to 350 CFM.

Single port blowers can be obtained up to 1210 CFM for use in large extruder installations. Consult Tempco with your requirements.

Single Port Large Volume Blower: Drawing 2

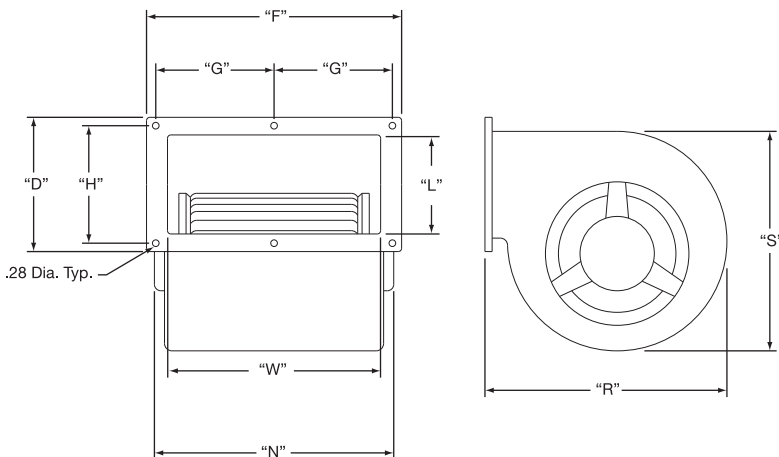

Note: Blower's wheel and motor assembly is mounted within the sheet metal housing, allowing air in from both ends.

Additional sizes of two-speed blowers rated 435/296 are also available. A full range of special dual inlet sizes from 120 CFM up to 1200 CFM can be supplied for extruder zone widths of 6" and longer. Consult Tempco with your requirements.

All CFM Values are with free inlet and discharge and 0" Static Pressure. All Dimensions are in inches.

Double Port Blower: Drawing 3

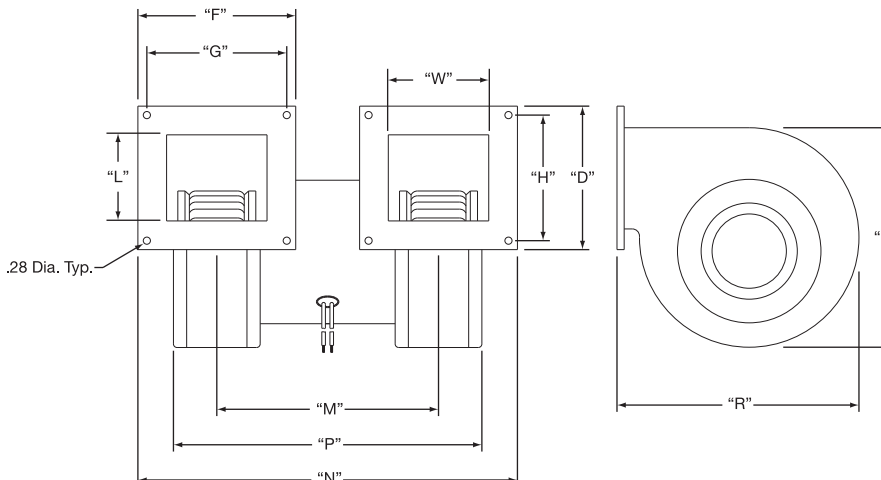

Note: A smaller 157 CFM version is also available. Special cast housing blowers rated 500 to 600 CFM for use on larger extruders can be obtained. Consult Tempco with your requirements.

Finned Air-Cooled

Standard Cast-In Finned Heater Designs for Air-Cooled Extruder Systems

Aluminum Finned Cast-In Band Heaters are used as an alternative to Liquid Cooled Cast-In Band Heaters for heating and cooling the barrels of plastic extruders.

As a standard, Finned Cast-In Band Heaters are manufactured in aluminum alloys because this material provides very good thermal conductive properties. For applications requiring higher operating temperatures and/or higher watt densities, bronze or brass alloys can be used.

Precision machining of the inside diameter yields superior heat transfer between the heater and the machine barrel, thereby

ensuring uniform heating and cooling of the extrusion process. The heaters are secured to the barrel either by Stainless Steel Clamp Bands or by means of Bolt Clamping the heater halves together.

Finned Cast-In Band Heaters can be designed to meet the mechanical and physical constraints of existing extruder shroud systems. They are manufactured for Original Equipment Manufacturers (OEM) and maintenance (MRO) applications to customer specifications.

Finned Cast-In Heater End Types

Type FS1 – Finned Cast-In Heater without Side Flanges

These cast-in band heaters are normally made to be used in conjunction with the Cool to-the Touch and Multi-Versal Shroud Systems. They can also be used as stand alone replacements for other heating and cooling extrusion systems.

The standard mounting method for these designs is bolt clamping. An alternative mounting method is to use stainless steel straps. Type "T" screw terminals are the standard termination. For other termination styles see pages 3-54 and 3-55.

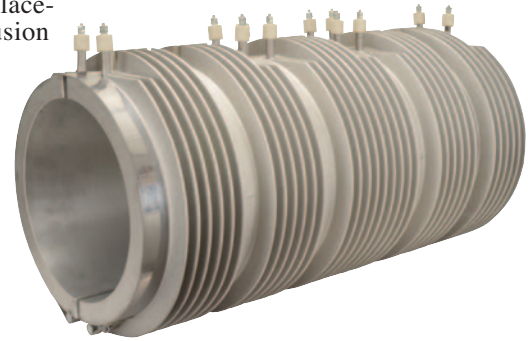

Type FS2 – Finned Cast-In Heater with Side Flanges

These cast-in band heaters are normally made to be used in conjunction with the Arctic Cast Shroud System. They can also be used as stand alone replacements for other heating and air cooling extrusion systems.

The standard mounting method for these designs is bolt clamping. An alternative mounting method is to use stainless steel straps. Type "E" screw terminals are the standard termination. For other termination styles see pages 3-54 and 3-55.

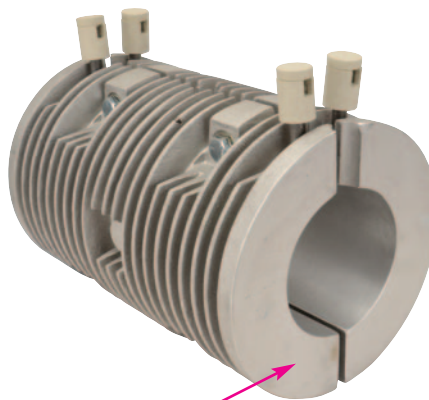

Side Flange



Side Flange

Ordering Information

See Page 3-47 for complete Ordering Information.



Stock and Standard (Non-Stock) Finned Aluminum Cast-In Band Heaters for Extrusion Processing

➤ **Standard Sizes and Ratings Listed by Extruder Size**

➤ **These Sizes and Ratings are among the most commonly used. They will provide the shortest delivery times.**

Stock Items Are Shown In RED

I.D. in	O.D. in	Length in	Material	Watts Each Half	Volts Each Half	Phase	Termination Type	Clamping Type	Heater End Type (pg 3-44)	Cast-In Heater Part Number
2.25	4	5.5	Bronze	600	230	1	R	Bolt	FS2	CBH12388
3	4.75	7.5	Bronze	1000	230	1	R	Bolt	FS2	CBH12387
3.75	8	9.875	Alum 319	1350	207	1	S	Bolt	FS2	CBH10404
4	8	8.75	Alum 443	2000	230	1	S	Strap	FS1	CBH09461
4	8	9	Alum 319	1500	230	1	S	Strap	FS1	CBH08712
4	8	11	Alum 319	1850	230	1	S	Strap	FS1	CBH08713
4.375	8.25	12.25	Alum 319	2000	230	1	R	Strap	FS1	CBH01139
4.5	8.25	12.5	Alum 319	2500	190	1	C4	Bolt	FS2	CBH14634
4.5	8.5	12	Alum 319	2750	240	1	R	Bolt	FS2	CBH06640
4.5	8.5	12	Alum 319	2750	200	1	R	Bolt	FS2	CBH08651
4.5	9	11.5	Alum 319	2000	230	1	S	Strap	FS1	CBH05533
4.921	8.421	9	Bronze	2500	480	3	C4	Strap	FS1	CBH08576
4.922	7.5	5.906	Alum 319	1630	230	1	T7	Bolt	FS2	CBH10044
4.922	7.5	7.087	Alum 319	2180	230	1	T7	Bolt	FS2	CBH10045
5	7.75	12.75	Alum 319	2625	200	1	R	Bolt	FS2	CBH11859
5	9	13	Alum 319	2750	240	1	S	Strap	FS1	CBH12840
5.002	9.25	12.25	Alum 319	2000	240	1	T	Strap	FS1	CBH03319
5.5	8.75	12.5	Alum 319	2800	600	1	S	Bolt	FS1	CBH07945
5.5	8.75	12.5	Alum 319	2800	460	1	S	Bolt	FS1	CBH07952
5.5	8.75	12.5	Alum 319	2800	240	1	S	Bolt	FS1	CBH10362
5.5	9.5	12	Alum 319	2300	240	1	S	Strap	FS1	CBH06724
5.5	9.5	12.5	Alum 319	2800	240	1	S	Bolt	FS2	CBH04982
5.5	9.5	12.5	Alum 319	2800	415	1	S	Bolt	FS2	CBH12906
6	10.5	11.5	Alum 319	2700	230	1	S	Strap	FS1	CBH02588
6	10.5	14.5	Alum 319	3500	230	1	T7	Strap	FS1	CBH02432
6.25	10.25	6.25	Alum 319	1400	200	1	S	Bolt	FS2	CBH08653
6.25	10.25	6.25	Alum 319	1700	240	1	R	Bolt	FS2	CBH06373
6.25	10.25	13.688	Alum 319	3000	230	1	R	Strap	FS2	CBH01406
6.25	10.25	17.75	Alum 319	5800	240	1	R	Bolt	FS2	CBH06623
6.25	11.25	15.875	Alum 319	5000	230	1	S	Bolt	FS1	CBH03365
6.3	9.55	15.75	Alum 319	5000	240	1	C4	Strap	FS1	CBH03793
6.3	9.55	15.75	Alum 319	5000	380	1	S	Strap	FS1	CBH11795
6.3	10.05	15.75	Alum 319	5000	380	1	S	Bolt	FS1	CBH12907
6.3	10.05	15.75	Alum 319	5000	415	1	S	Bolt	FS1	CBH12908
6.3	10.05	15.75	Alum 319	5000	440	1	S	Bolt	FS1	CBH12668
6.5	9.5	15	Alum 319	3250	230	1	T7	Bolt	FS1	CBH14207
6.5	9.5	17.5	Alum 356	3400	230	1	T	Bolt	FS2	CBH07553
6.5	10.5	13	Alum 319	4300	230	1	E	Bolt	FS2	CBH09631
6.5	10.5	13	Alum 319	4300	190	1	E	Bolt	FS2	CBH09424
6.6	10.625	14.75	Alum 319	3250	240	1	S	Strap	FS1	CBH07649
6.625	9.875	18	Alum 319	4400	600	1	S	Bolt	FS1	CBH07946
7	10.25	18	Alum 319	6000	290	3	E	Strap	FS2	CBH09420
7.5	11	16.5	Bronze	5100	230	1	R	Strap	FS2	CBH11105
7.5	11.25	19	Alum 319	8000	380	1	S	Bolt	FS1	CBH12447

Key for Abbreviations found under the Termination Column

- | | |
|---|---|
| C4 = Screw Terminal with Ceramic Cover | R1A = Stainless Steel Wire Overbraid |
| E = Right-Angle Lug | R2 = Blockhead Screw Terminal |
| F = Flexible Lead Wire | S = Screw Terminal with Heavy Duty Ceramic Insulator |
| R = 90° Blockhead Screw Terminal | T = Screw Terminal with Mica Insulator |
| R1 = Flexible Armor Cable | T7 = Screw Terminal with Ceramic Insulator |

CONTINUED ➔

Cast-In Heaters



Finned Air-Cooled

Standard (Non-Stock) Finned Aluminum Cast-In Band Heaters for Extrusion Processing

Continued from previous page...

I.D. in	O.D. in	Length in	Material	Watts Each Half	Volts Each Half	Phase	Termination Type	Clamping Type	Heater End Type (pg 3-44)	Cast-In Heater Part Number
7.5	11.5	19.5	Alum 319	6000	240	1	C4	Strap	FS1	CBH10129
7.5	12	18	Alum 319	4500	230	1	S	Strap	FS2	CBH07058
7.625	11.625	14.438	Alum 319	3500	230	1	R	Strap	FS2	CBH01401
7.68	12	8.46	Alum 319	4000	230	1	R1A	Bolt	FS2	CBH10371
7.68	13.43	8.46	Alum 319	4000	230	1	R1A	Bolt	FS2	CBH07906
7.68	13.43	8.46	Alum 319	4000	230	1	C4	Bolt	FS2	CBH09690
8	12	8	Alum 319	2500	240	1	S	Bolt	FS2	CBH06574
8	12	8	Alum 319	2500	300	1	S	Bolt	FS2	CBH06144
8	12	8	Alum 319	2850	240	1	S	Bolt	FS2	CBH06642
8	12	10	Alum 319	3550	240	1	R	Bolt	FS2	CBH06643
8	12	17.5	Alum 319	4600	575	3	S	Bolt	FS1	CBH08418
8	12	20	Alum 319	5600	240	1	S	Bolt	FS2	CBH11002
8	12.01	12.625	Alum 319	2875	240	1	R	Bolt	FS2	CBH13795
8.25	12.25	16	Alum 319	7000	230	3	E	Bolt	FS2	CBH10653
8.25	12.25	16	Alum 319	10000	200	3	R1	Bolt	FS2	CBH11081
8.268	11.504	21.457	Alum 319	7500	240	3	C4	Strap	FS1	CBH04167
8.5	11	12.75	Alum 319	4500	460	3	S	Bolt	FS1	CBH12389
8.5	11.5	20.5	Alum 319	6300	240	3	T	Bolt	FS1	CBH10923
8.5	11.75	10	Alum 319	4425	190	3	E	Strap	FS2	CBH14903
8.5	12	8.5	Alum 319	2750	230	1	S	Strap	FS1	CBH05417
8.5	12.25	6	Alum 356	2250	230	1	S	Bolt	FS1	CBH13082
8.502	13.5	12.75	Alum 319	4500	415	3	S	Bolt	FS1	CBH09902
8.502	13.5	12.75	Alum 319	4500	480	3	S	Bolt	FS1	CBH07212
9.5	12.5	27.25	Alum 319	12000	230	3	T	Bolt	FS1	CBH09759
9.5	13	5	Alum 319	2250	480	1	R2	Bolt	FS2	CBH14691
9.5	13.25	25.5	Alum 319	15000	380	1	S	Bolt	FS1	CBH12448
9.5	13.75	20.5	Alum 319	6000	575	3	E	Bolt	FS1	CBH10947
9.502	14.5	13	Alum 319	5250	480	3	T7	Bolt	FS2	CBH07231
9.75	13.25	21.25	Alum 319	7500	480	3	T	Bolt	FS1	CBH14419
9.75	13.25	25	Alum 319	9000	230	3	T	Bolt	FS1	CBH10138
9.75	13.75	17.75	Alum 319	7500	230	1	S	Bolt	FS1	CBH07658
9.75	13.75	22	Alum 319	7000	230	1	C4	Bolt	FS2	CBH10177
9.75	13.75	22	Alum 319	11000	200	3	F	Bolt	FS2	CBH11080
9.75	13.875	23.875	Alum 319	6000	230	1	R	Strap	FS2	CBH02945
9.75	14	19.438	Alum 319	6000	230	1	R	Strap	FS2	CBH01262
9.84	14.156	6.06	Alum 319	4000	230	1	R1A	Bolt	FS2	CBH10372
9.875	13.875	8.5	Alum 319	3500	240	1	R	Bolt	FS2	CBH06644
10	13	8	Alum 319	4600	240	1	T	Bolt	FS2	CBH06570
10.039	13.289	12.992	Alum 319	6000	230	3	C4	Strap	FS1	CBH04738
10.623	13.625	13.75	Alum 319	3000	480	1	T	Strap	FS1	CBH11140
12.25	18.5	11.563	Alum 356	5500	460	1	R1A	Bolt	FS1	CBH11575
13	17	7	Alum 319	3450	190	1	R	Bolt	FS2	CBH09810
13	17	7	Alum 319	3450	240	1	R	Bolt	FS2	CBH06583
15.75	20.875	3.25	Alum 319	2000	282	1	F	Bolt	FS2	CBH10084
18.897	24.02	3.346	Alum 319	2250	266	1	F	Bolt	FS2	CBH10224

Key for Abbreviations found under the Termination Column

- C4** = Screw Terminal with Ceramic Cover
- E** = Right-Angle Lug
- F** = Flexible Lead Wire
- R** = 90° Blockhead Screw Terminal
- R1** = Flexible Armor Cable
- R1A** = Stainless Steel Wire Overbraid
- R2** = Blockhead Screw Terminal
- S** = Screw Terminal with Heavy Duty Ceramic Insulator
- T** = Screw Terminal with Mica Insulator
- T7** = Screw Terminal with Ceramic Insulator



Note: For Sizes and Ratings not listed, Tempco will manufacture a Cast-In Heater to your specifications. See page 3-47 for how to order.

Cast-In Finned Band Heaters Quote Request Form

Finned Cast-In Band Heater Bolt Clamping

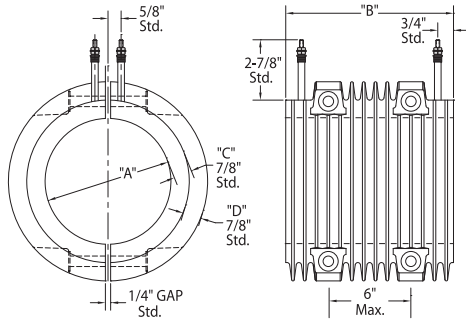

Finned Cast-In Band Heater Strap Clamping

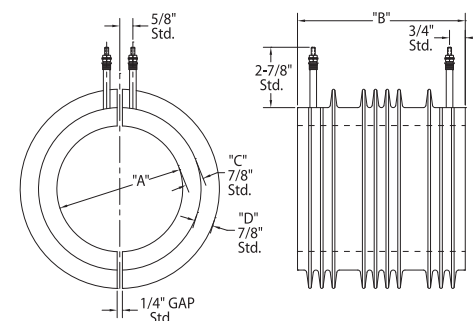

Recommended dimensions shown.

Ordering Information

To process your order or quotation, please specify the following information.

Dimensions

Inside Dia. "A" _____ Length "B" _____
 Thickness "C" _____ Fin Height "D" _____

Material Specifications

Aluminum Bronze Brass

Heater End Type

Type FS1 Type FS2
 (See page 3-44 for details.)

Clamping Style

Straps Bolt Clamp

Electrical Specifications

Watts each half _____ Volts each half _____ Phase _____

Terminal Style

"S" Post Terminals "T" Mica Washers "T7" Post Terminals
 "F" Plain Leads "TS" Leads and Shrink Sleeve
 "C4" Ceramic Cover "R1" Armor Cable Leads
 "E" Right-Angle Lugs Other: See pages 3-54 and 3-55 for additional terminations

Surface Finish

125 RMS Standard or to Customer Specifications

Special Cast-In Features

Holes, Cutouts, Slots, Bevels, Mounting Studs, Stand-Offs and Taper Angles
For special features a detailed drawing is required.



Note: For additional cooling, fin castings can be designed with cooling tubes. Consult Tempco with your requirements.

WARNING: Cancer and Reproductive Harm - www.P65Warnings.ca.gov.

Reasons Why OEMs

Specify Tempco's Quality

Liquid-Cool Cast-In Aluminum Heaters

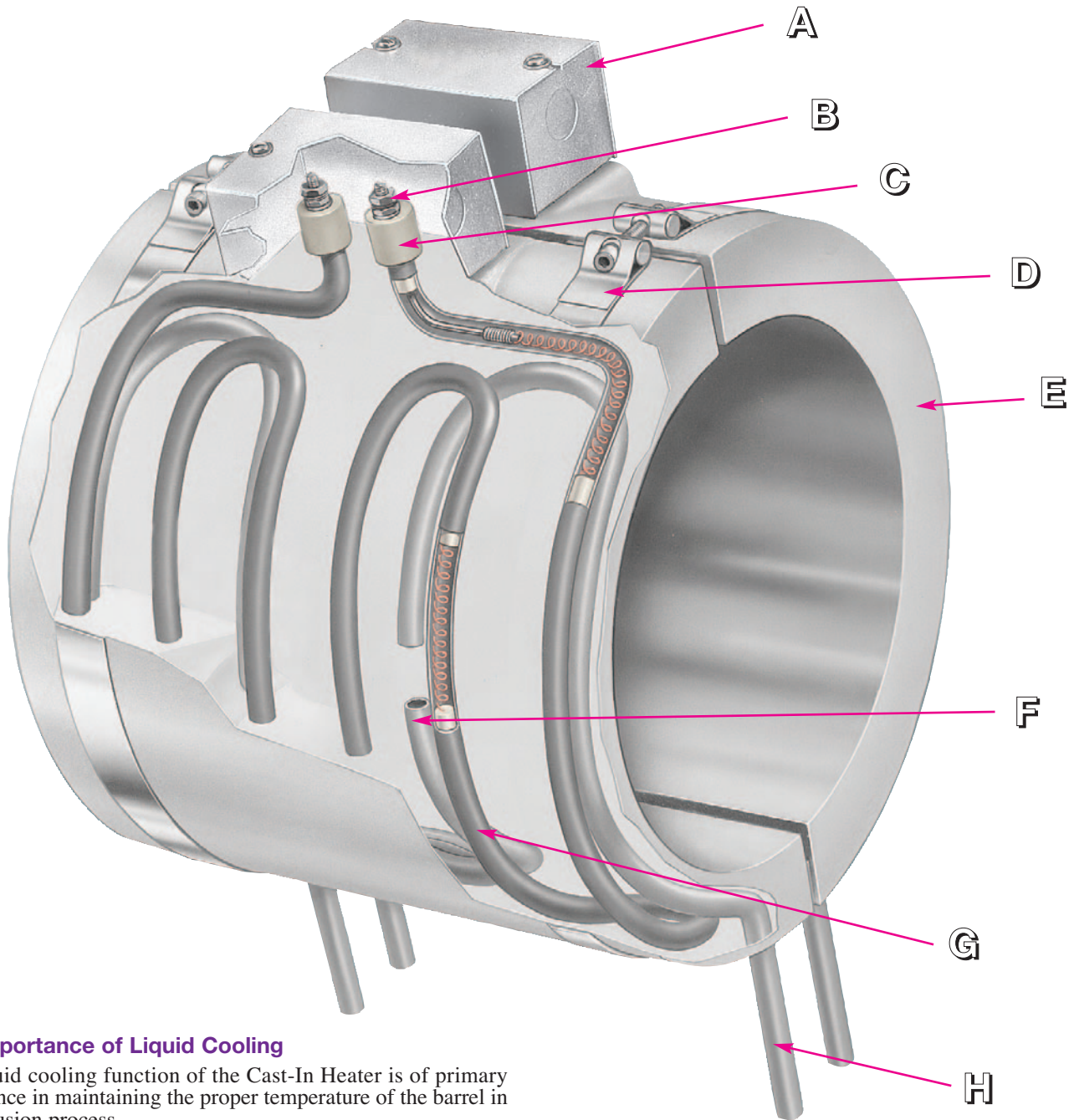

The Importance of Liquid Cooling

The liquid cooling function of the Cast-In Heater is of primary importance in maintaining the proper temperature of the barrel in the extrusion process.

Tempco offers many different liquid cooling variations, styles and terminations. The following pages will assist you in selecting the liquid cooling system best suited to your application. See page 3-63 for complete details on how to order.

THE PERFORMANCE FACTS

A General purpose stainless steel terminal boxes provide a simple and economical way to eliminate exposure to live electrical terminals. To simplify electrical wiring, the box has two knockouts for standard 1/2" BX cable connectors. Boxes can be supplied factory prewired with high temperature lead wire protected with armor cable or wire braid. Other boxes are available to accommodate your requirements. See pages 3-56 and 3-57.

B Threaded post terminals with 10-32 threads are securely fastened to the tubular heating element cold pin, assuring positive electrical contact for maximum amperage carrying capacity. Other terminations are available to accommodate your requirements. See pages 3-54 and 3-55.

C The standard Type "S" terminal has specially designed ceramic insulators that provide support to the screw terminals. The tubular heater is recessed into the insulator to help prevent the screw terminals from bending or breaking from mechanical abuse. Other specially designed ceramic insulators are available for the screw terminals and the connecting wire. See page 3-54.

D Specially designed, low expansion 430 stainless steel clamping straps with 1/4"-20 socket head cap screws and barrel nuts, in either 3/4" or 1-1/4" widths, are supplied as our standard method for securing the casting to the barrel. The number and width of the straps is determined by the length and weight of the heater. For optional bolt and nut clamping design see page 3-50.

E Having an in-house foundry gives us the flexibility to apply sound foundry techniques to control the quality of each casting. Specially designed steel and cast iron molds are used in our Permanent Mold Casting Process, producing a dense casting, free of internal voids with smoother as-cast surfaces. When casting small quantities, the No-Bake Sand Mold process is used. This process produces a better quality casting than other sand processes. The inside diameter of all Cast-In Band Heaters is machine finished to customer specifications.



F A critical consideration in the design of a heat and liquid cooled Cast-In Heater is the cooling tube itself, since cooling tube failures usually occur before heating element failures. Tempco has devoted many years of research and testing to select alloy tubes that are resistant to corrosion, and that will also withstand the continuous stress that is placed on the cooling tube. Our testing also included developing the proper tube forming techniques to limit the effects of thermal shock from repetitive heat/cool cycling that can produce stress cracking, especially at the point the cooling tube exits the casting.



G To maintain lower watt densities important for good heater life, the largest possible diameter steel sheath tubular heater is used. Tempco most commonly uses a .430 diameter element with 1/8" diameter cold pins. This pin size allows installation of larger and stronger screw terminal connections, providing additional strength to prevent broken terminals due to mechanical abuse.

H Cooling tube extensions can be cut to your specified length, with various types of tube fittings factory installed. The casting can also be supplied with non-exposed cooling tube fittings, which reduce cooling tube failure due to stress corrosion cracking. For a complete selection of cooling tube terminations see page 3-52.

Liquid-Cooled Cast-In Band Heaters for Extrusion Processing

Single Set of Cooling Tubes—The Industry Standard

The single set cooling tube design features 1/4", 3/8" or 1/2" diameter tubing precisely formed into a serpentine or any other suitable shape and cast into the body of the Cast-In Heater. This is the most widely used method for providing a means of cooling in liquid-cooled Cast-In Heaters.

From this basic design, the user can choose to factory equip the cooling tubes with any of the cooling tube termination options shown on page 3-52. Electrical termination options are shown on pages 3-54 and 3-55. The two most common clamping variations are shown below.



Type CW—Single Cooling Tube with Strap Clamping

Type CW Cast-In Band Heaters consist of liquid cooled and/or heating functions, and are secured to the extruder barrel with 3/4" or 1-1/4" wide low expansion stainless steel clamping straps with 1/4"-20 socket head cap screws and barrel nuts.

If not otherwise specified, supplied with Type S electrical screw termination, 3" long cooling tube extensions and straps for clamping. For a wide selection of electrical and cooling tube termination options, see pages 3-52 through 3-55. See page 3-63 for complete details on how to order.

Type CWB—Single Cooling Tube with Bolt Clamping

Type CWB Cast-In Band Heaters consist of liquid cooled and/or heating functions, and are secured to the barrel by bolts clamping the two halves together around the barrel. A variety of bolt clamping designs and hardware is available. Consult Tempco with your specific requirements.

If not otherwise specified, cast-in band heaters are supplied with Type S electrical screw termination and 3" long cooling tube extensions. For a wide selection of electrical and cooling tube termination options, see pages 3-52 through 3-55. See page 3-63 for complete details on how to order.

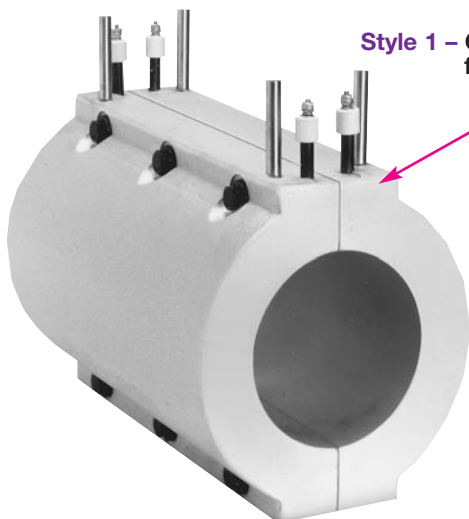

Style 1 – Continuous Flange for Bolt Clamping

Style 2 – Segmented Pads for Bolt Clamping

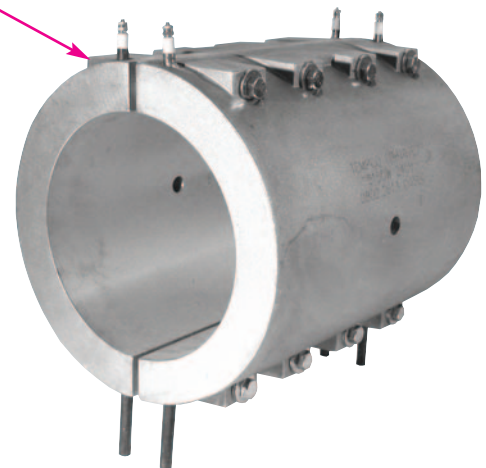

Liquid-Cooled Cast-In Band Heaters for Extrusion Processing

Type CWW — Dual Set of Cooling Tubes within the Same Cast-In Heater

The Dual cooling tube design incorporates two sets of 3/8" or 1/2" diameter tubing formed into a serpentine or any other suitable shape within the same Cast-In Heater. Dual cooling tubes will actually double the operating life of a Cast-In Heater with liquid-cool function, since cooling tube failures usually occur before heating element failures.

There are two main causes for failure on liquid-cooled Cast-In Heaters: Stress corrosion cracking at the exiting point of the tube extensions and clogged lines due to scale build-up that reduces flow, decreasing cooling capacity and finally completely blocking the tube. Once the first set of cooling tubes has failed, reconnect to the spare set and you are back in operation, thus eliminating costly downtime and additional labor for heater replacement. Dual cooling tubes are also used when additional cooling capacity is required.

Cooling tube extensions can be factory equipped with your choice of fittings. Clamping styles are low thermal expansion alloy straps or bolt clamping. If not otherwise specified, supplied with Type S electrical screw termination, 3" long cooling tube extensions and straps for clamping. For a wide selection of electrical and cooling tube termination options, see pages 3-52 through 3-55. See page 3-63 for complete details on how to order.

Design Features

- * Double operating life
- * Greater reliability
- * Reduces costly downtime
- * Better cooling capacity
- * Reduces heater replacement inventory
- * Various heater terminations
- * Available in Bolt Clamping and Strap Clamping
- * Made to customer specifications

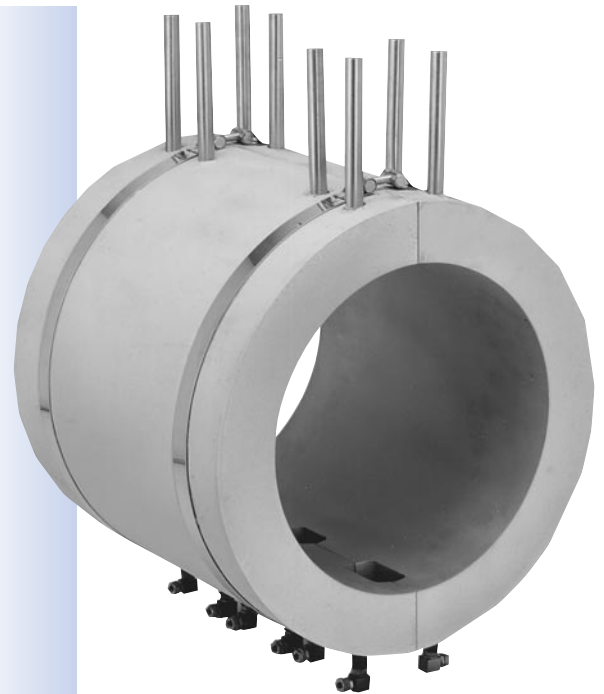

Type RC — Non-Exposed Cooling Tubes Recessed NPT Fittings

The recessed cooling tube design incorporates 3/8" or 1/2" diameter tubing formed into a serpentine or any other suitable shape with specially designed stainless steel NPT fittings that are welded to the tube ends and cast below the surface of the Cast-In Heater, thus eliminating the troublesome, commonly used tube extensions as they exit the casting for connection to the coolant lines.

Non-exposed fittings will drastically increase the operating life of a Cast-In Heater with liquid cool function, as this feature eliminates broken and/or damaged cooling tube extensions which are a major factor in premature heater failure. Type RC fittings are available in two female NPT thread sizes, 3/8"-18 and 1/2"-14. Standard clamping styles for Cast-In Band Heater sets are low thermal expansion alloy straps or bolt clamping. Specify fitting thread size and clamping style when ordering. If not otherwise specified, supplied with Type S electrical screw termination and straps for clamping. For fittings with special thread size, consult Tempco with your requirements. See page 3-63 for complete details on how to order.

Design Features

- * Quick and easy installation
- * Exceptionally longer Cast-In Heater life
- * Reduces costly downtime
- * Greater reliability
- * Rugged, durable construction
- * Available on all cooling tube sizes
- * Available in Bolt Clamping and Strap Clamping
- * Made to customer specifications



Cooling Tube Termination Options for Liquid-Cooled Cast-In Band Heaters



Type FF Flared Seal Fittings

Brass flared seal fittings are well adapted for low to medium pressure and resistant to mechanical pullout. Available for 3/8" and 1/2" diameter tubing with SAE 45° flare.

Diameter Tubing	Thread	Part Number
3/8"	5/8"-18	FTG-124-101
1/2"	3/4"-16	FTG-124-104

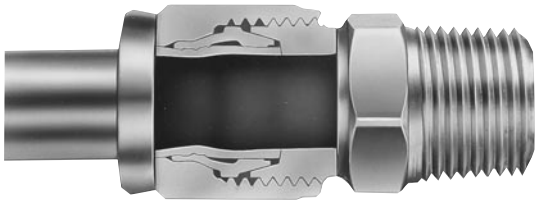

Type HS Hi-Seal Fittings

Hi-seal brass fittings are highly dependable under the most adverse conditions. For reliable and trouble-free service with ease of installation, we strongly recommend hi-seal fittings. Available for 3/8" and 1/2" diameter tubing. Male thread is 1/2" NPT for 1/2" tube and 3/8" tube.

Diameter Tubing	Part Number
3/8"	FTG-118-124
1/2"	FTG-118-116



Type RA 90° Copper Elbow

90° copper elbow is brazed to the Cast-In Heater cooling tube extension with additional tube extension for connecting cooling lines with compression and/or flared fittings. Available for 3/8" and 1/2" diameter tubing. If required, specify.

Diameter Tubing	Part Number
3/8"	FTG-127-102
1/2"	FTG-127-103



Type RT Cast Brass 90° Threaded Elbow

90° threaded elbow is brazed to the cooling tube extension, providing an easy and quick method for connecting cooling lines. Recommended to be factory installed to assure good braze seals. Available for 3/8" and 1/2" NPT internal threads. If required, specify.

Diameter Tubing	NPT	Part Number
1/2"	3/8"	FTG-125-101
1/2"	1/2"	FTG-125-102



Type R3 Straight Threaded Copper Fitting

Straight threaded fitting is brazed to the cooling tube extensions, providing an easy and quick method for connecting cooling lines. Recommended to be factory installed to assure good braze seals. Available for 3/8" and 1/2" diameter tubing with internal threads. If required, specify.

Diameter Tubing	NPT	Part Number
3/8"	3/8"	FTG-131-103
1/2"	3/8"	FTG-131-102
1/2"	1/2"	FTG-131-101

Installation Accessories for Liquid-Cooled Cast-In Band Heaters

Stock Tubing for Cooling Lines

Cooling Line Tubing can be used to connect the Tempco Cast-In heat/cool bands to the plumbing system of your extruder. Tubing is available in 6'8" lengths for U.P.S. shipments and up to 20' lengths for truck shipments. Barlow's formula below was used to calculate Working Pressure in the table.

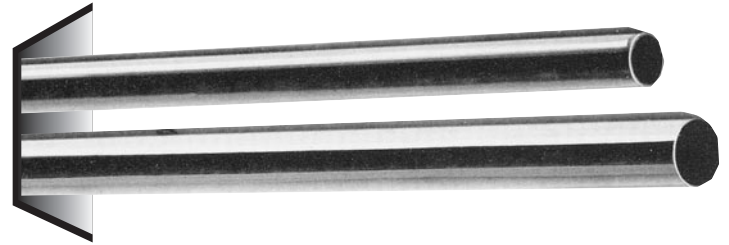

$$\text{Maximum Working Pressure (PSIG)} = \frac{2 \times \text{Material Strength (PSI at Room Temperature)} \times \text{Wall Thickness of Tube (in)}}{\text{OD of Tube (in)} \times \text{SF (Safety Factor of 1.5 to 10 depending on application)}}$$

Tubing Diameter (in)	Material	Wall Thickness (in)	Burst Pressure (PSI)	Working Pressure (Safety Factor 4) (PSI)	Material Strength (PSI)	Volume (in ³ /ft)	Part Number
1/4	304 SS	0.028	11200	2800	75000	0.3547	TUB-101-130
3/8	304 SS	0.035	14000	3500	75000	0.8767	TUB-101-108
1/2	304 SS	0.049	14700	3675	75000	1.5231	TUB-101-110
1/2	304 SS	0.065	19500	4875	75000	1.2903	TUB-101-122
1/2	Incoloy	0.049	17052	4263	87000	1.5231	TUB-111-108

Flexible Teflon® Wire Braided Hose

Flexible Teflon® Wire Braided Hose provides an excellent means of connecting Cast-In Heaters to the extruder plumbing system. This style of hose meets the demands of medium to tight bending radius requirements. The stainless steel braid protects the Teflon® hose from any harsh mechanical conditions that may be present.

A variety of brass male and female threaded fittings can be incorporated onto the hose, making it a practical choice for use in conjunction with Tempco's Style RC Non-Exposed Fittings and other available fittings.

Rigid brass adapter fittings as listed below are used to mate the base hose assembly to your existing installation. This allows for the installation of the rigid NPT coupling into the plumbing system and then attaching the swivel fitting on the hose, making assembly relatively easy. Remember to use Teflon® tape or equivalent.

Standard Hose: Size 8 (1/2") .405" I.D., .549" O.D.
Operating Pressure: 2000 PSI
Burst Pressure: 8000 PSI



Ordering Information

The standard hose assemblies are supplied with 1/2" female 37° SAE flare swivel style crimped-on fittings. The hose assemblies can be ordered in 6" increments starting at 18" minimum. Fitting material is Brass.

Part Number*
 WHT05

*Complete the Part Number with length of hose in 6" increments starting at 18" (018).

Standard lead time is 2 weeks or less.

Adapter Fittings for Flexible Teflon® Wire Braid Hose

Rigid brass adapter fittings are used to mate the base hose assembly to your existing installation.

T1	T2	Part Number
1/2" male 37° SAE flare	1/2"-14 NPT male	FTG-161-103
1/2" male 37° SAE flare	1/2"-14 NPT female	FTG-161-102
1/2" male 37° SAE flare	3/8"-18 NPT male	FTG-161-104
1/2" male 37° SAE flare	3/8"-18 NPT female	FTG-161-105



⚠ WARNING: Cancer and Reproductive Harm - www.P65Warnings.ca.gov.

Standard Tubular Heater Terminations for Cast-In Heaters

Select the termination style that meets your requirements for space, accessibility and reliability.

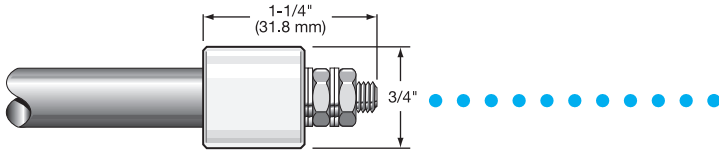

Type S Standard Unless Otherwise Specified

Heavy Duty Ceramic Insulators.

- .315" diameter heater has 8-32 screw terminals.
- .430" diameter heater has 10-32 screw terminals.

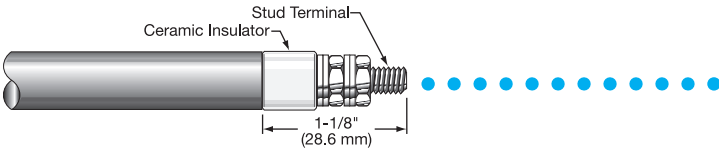

Type T7

Ceramic insulator is the same diameter as the heating element.

- .260" diameter heater has 6-32 screw terminals.
- .315" diameter heater has 8-32 screw terminals.
- .430" diameter heater has 10-32 screw terminals.

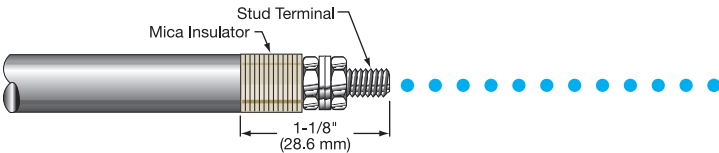

Type T

Mica insulator is the same diameter as the heating element.

- .260" diameter heater has 6-32 screw terminals.
- .315" diameter heater has 8-32 screw terminals.
- .430" diameter heater has 10-32 screw terminals.

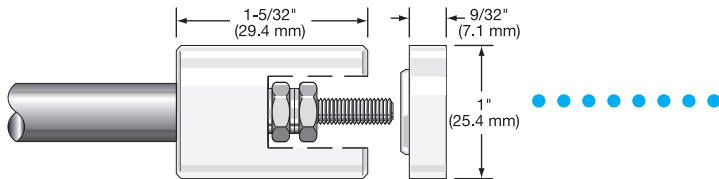

Type C4

Heavy duty ceramic insulator with terminal cover.

- .315" diameter heater has 10-32 screw terminals.
- .430" diameter heater has 10-32 screw terminals.



TYPE P—Plain Pin

Plain terminal pin. Specify Length "L." Standard 1/2" (12.7 mm) pin length.

Element Diameter		Nominal Pin Diameter	
in	mm	in	mm
.260	6.6	.091	2.3
.315	8.0	.100	2.5
.430	10.9	.120	3.0

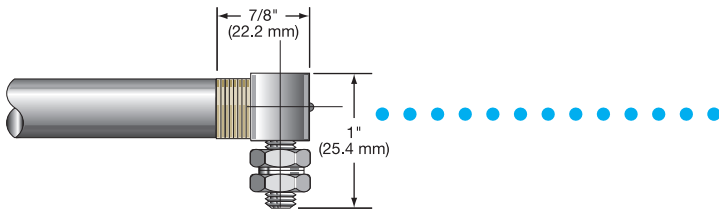

Type R

Mica washers with 90° blockhead screw terminal with 10-32 screw threads. Available for .315" and .430" diameter heaters.

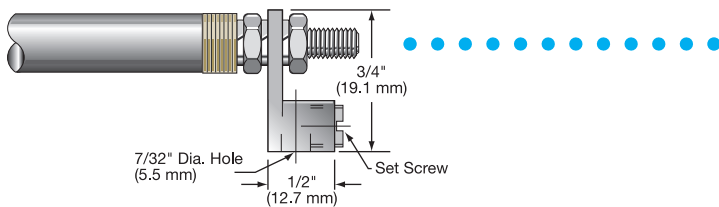

Type R2

Mica washers with blockhead and through hole for lead wire connection. Eliminates the use of ring terminals. Available for .315" and .430" diameter heaters. Accepts 6-14 gauge wire.

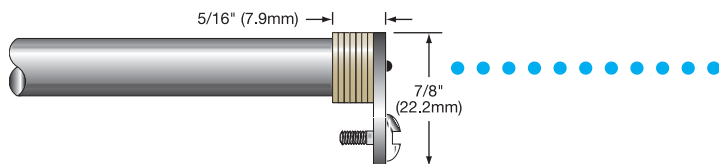

Type E

Right-angle lug welded to pin with mica washer insulators and 10-32 binding head screw. Available for .260", .315" and .430" diameter heaters.

Standard Tubular Heater Terminations for Cast-In Heaters

Select the termination style that meets your requirements for space, accessibility and reliability.

Type L & L9

Terminal lug spot welded to pin with 10-32 binding head screw. Available for .260", .315" and .430" diameter heaters. Type L represents straight; Type L9 represents 90° to pin. Specify lug orientation.

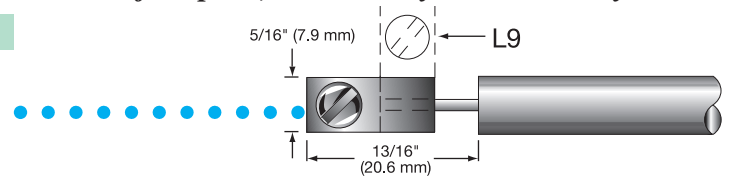

Type SF & SF9

Quick-disconnect spade tabs spot welded to pin. Available for .260", .315" and .430" diameter heaters. Type SF represents straight. Type SF9 represents 90° to pin. Specify tab orientation.

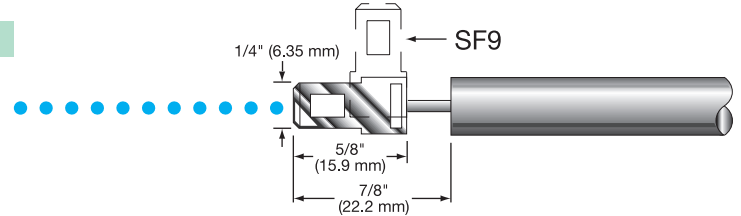

Type F

Flexible lead: insulated stranded wire crimped to cold pin. Crimp connection is insulated with fiberglass sleeving. Available for .260", .315" and .430" diameter heaters. Wire insulation rated to 250°C, 450°C optional. Specify lead length.



Type R1

Flexible Armor Cable provides excellent protection to lead wires against abrasion and contaminants. Available for .260", .315" and .430" diameter heaters. Specify cable length and lead length. Style may vary from depiction depending on heater diameter and cable diameter used.

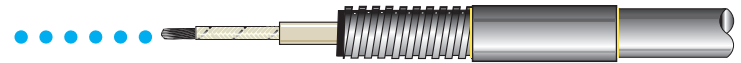

Type R1A

Stainless Steel Wire Overbraid provides flexibility and excellent protection to lead wires against abrasion. Available for .260", .315" and .430" diameter heaters. Specify stainless steel wire overbraid length and lead length. Style may vary from depiction depending on heater diameter and braid diameter used.



Type MR

Moisture resistant shrink strain relief and lead wire with or without stainless steel overbraid. Available for .260", .315" and .430" diameter heaters. Specify lead wire and overbraid length. Maximum operating temperature is 350°F (177°C).

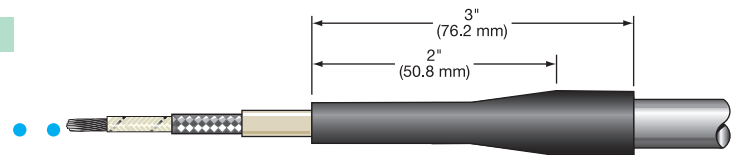

Type TS

Contamination seal shrink-down Teflon® sleeving over the heater and lead wire splice. Provides a good moisture resistant seal. Maximum operating temperature 500°F (260°C). Available for .260", .315" and .430" diameter heaters. Specify lead length.

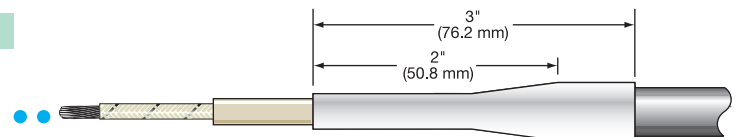

Type P1

Quick -disconnect plug, either mounted directly on casting or on elements ends offset a specified distance from casting. Rating: 16A-250VAC.



General Purpose Terminal Protection Boxes For Cast-In Heaters

Standard Box Type C2

Terminal Boxes provide a simple and economical means to eliminate exposed heater terminals and live electrical wiring, protecting employees from potential electrical shock. They also eliminate electrical shorts that can result from exposed wiring on Cast-In Heater installations.

Type C2 is an individual terminal box for protecting the terminals on each Cast-In Band Heater half. It is also used on many other Cast-In Heater designs with one set of heater terminals. The C2 box design requires a flat pad on half-round castings or a flat surface on other casting designs for mounting. It is made from heavy gauge, rust-resistant sheet metal. The cover is removable for easy access to terminals. The box has two 7/8" diameter knockouts opposite each other for standard 1/2" BX connectors.

To simplify installation, Cast-In Heaters fitted with boxes can be factory pre-wired with high temperature lead wire that can be protected with armor cable. If one of these options is required, **specify terminal box type, lead wire and cable length**. Satisfies NEMA 1 requirements.

Standard C2 box size: L = 4" W = 2-1/2" H = 2-1/8"



Terminal Protection for Both Heater Halves Type C7

Type C7 terminal boxes are made from rust-resistant sheet metal. The C7 base is fixed to the clamping straps. The box has two 7/8" diameter knockouts opposite each other for standard 1/2" BX connectors. The cover is removable, providing easy access to the screw terminals for electrical wiring.

To simplify installation, Cast-In Heaters fitted with boxes can be factory pre-wired with high temperature lead wire, protected with armor cable. If either one of these options is required, **specify terminal box type, lead wire and cable length**. Satisfies NEMA 1 requirements.

C7 Terminal Box Size varies with dimensions of casting.



Quick-Disconnect High Temperature Cup and Box Assembly Type P2

Quick-Disconnect Cup assemblies provide the simplest and safest means for applying power to any type of Cast-In Heater installation. The box extends over the screw terminals on both Cast-In Band Heater halves. The combination of prewired cup and box assembly, along with factory prewired high temperature lead wire protected with armor cable, eliminates live exposed heater terminals and electrical wiring, protecting employees from electrical shock and the possibility of electrical shorts due to exposed wiring.

If prewired plugs are required, **specify length of lead wire and cable**.

Rated 250V maximum, 15 Amp maximum

Terminal Box Size varies with dimensions of casting.



Terminal Protection Boxes for Cast-In Heaters



Type EP Explosion and Moisture Resistant Box

Cast iron explosion and moisture resistant boxes should be used in areas where the surrounding air may become contaminated with combustible gases or a high humidity level may exist. Installation requires one box per Cast-In Heater half and they are brazed to the tubular heater. The standard box has one 1/2" NPT hub.

Optional: Two hubs per box available. Cast-In Heater fitted with boxes can be factory prewired with high temperature lead wire, protected with special armor cable. If either of these options is required, please specify the following:

- Number of hubs
- Cable type
- Lead wire length
- Cable length

Type MPR Moisture Resistant Box

This design has a moisture resistant die cast aluminum box with a non-removable polyurethane gasket in the lid. Lid is secured with captive stainless steel screws. Body and lid are painted in basic industrial gray; interior contains copper ground screw. Box is mounted to a plate that is brazed to the element. Available in a wide variety of sizes.

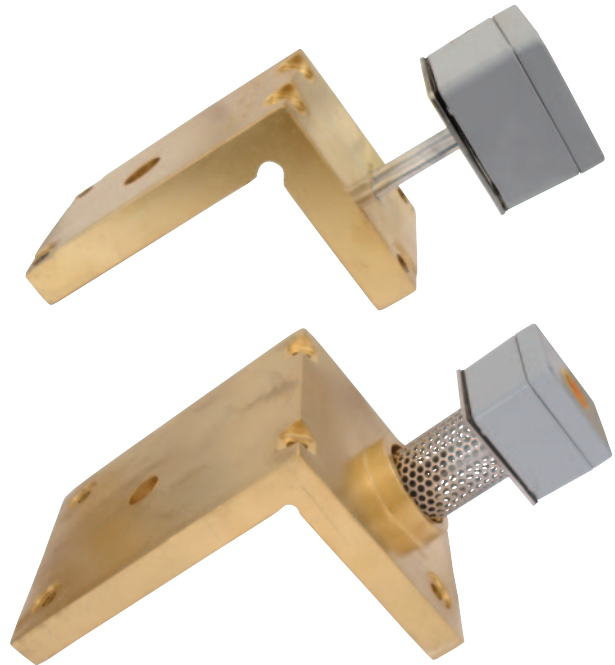

Type MR1 Moisture Resistant Box with Perforated Shield

This design incorporates the MPR housing style along with a perforated tube shielding unheated extensions of the tubular heating elements. This feature provides mechanical strength to the element extension and prevents overheating of the terminals, reducing possible premature failure from corrosion and oxidation.



Type CB

A cast box mounted directly on the casting is used to protect the termination.

Exposed electrical wiring on cast-in heater installations is a violation of Electrical Safety Codes including O.S.H.A.



Cast-In Band Heater Selection for Plastics Extrusion & Downstream Equipment

The Cast-In Band Heater listings on the following pages constitute a small segment of the thousands of Cast-In Band Heaters we have produced for plastics processing equipment. So that we may assist you in selecting the exact heater replacement for your machine, adhere to the following instructions:

1. Measure the O.D. of your barrel, which in turn will be the I.D. of the heater.
2. Measure the width of your heater.
3. Check the wattage and voltage rating per half or per segment. This information is normally stamped on the heater.
4. Establish heater cooling function, if any. If water cooled, measure length and diameter of cooling tube extensions. Cooling tube extensions are 3" long, and 1/2" x .049 O.D. wall thickness unless otherwise specified. If air cooled, Cast-In Band will have fins.
5. Check for special features such as: thermocouple clearance holes, drill and tapped holes, vent cutouts and terminal boxes.
6. There are two methods for securing a Cast-In Band Heater to a barrel: separate clamping straps or nut and bolt clamping.
7. Once you have established this information, proceed to match your heater description with one of our standard Cast-In Band Heaters. Starting with the I.D., read across the chart until you have a perfect match. Wattage can vary up to 15% either way with little or no effect to your process.

Stock and Standard (Non-Stock) Cast-In Band Heaters for Plastics Extrusion

I.D. in	O.D. in	Length in	Material	Watts Each Half	Volts Each Half	Phase	Termination Type	Terminal Box Type	Cooling Tube	Cooling Termination	Clamping	Cast-In Heater Part Number
2.25	4	17	Bronze	2000	480	1	R1	None	None	None	Strap	CBH08136
2.25	4.25	5	Bronze	1200	480	1	R1A	None	None	None	Strap	CBH08421
2.375	4.375	22	Brass	500	240	1	T7	EP	None	None	Bolt	CBH14001
2.5	4	6.25	Alum 319	750	208	1	F	None	None	None	Strap	CBH09711
2.75	4.75	2	Bronze	450	230	1	R2	None	None	None	Strap	CBH09227
3	4.5	2.5	Brass	350	120	1	E	None	None	None	Strap	CBH08847
3	4.75	4.5	Bronze	500	120	1	T7	None	None	None	Bolt	CBH05210
3	5	5.5	Alum 319	1000	230	1	T	None	None	None	Strap	CBH03097
3	5	5.5	Bronze	1000	230	1	T	None	None	None	Strap	CBH06726
3.125	4.625	3	Alum 319	400	220	1	R1	None	None	None	Strap	CBH06992
3.15	4.25	2	Brass	250	110	1	R1A	None	None	None	Strap	CBH08696
3.25	6.25	10	Alum 319	750	115	1	S	None	Single	None	Strap	CBH09445
3.5	6	17	Bronze	1250	208	1	R1	None	None	None	Strap	CBH04875
3.5	6.5	7.375	Alum 319	1500	230	1	S	None	Single	None	Strap	CBH10460
3.51	5.5	3.5	Alum 319	250	120	1	C4	None	None	None	Strap	CBH13189
3.8	6.55	3.75	Brass	1000	460	1	T7	EP	Single	HS	Strap	CBH12488

Key for Abbreviations found under the Termination Type Column

- | | |
|---|---|
| C4 = Screw Terminal with Ceramic Cover | R1A = Stainless Steel Wire Overbraid |
| E = Right-Angle Lug | R2 = Blockhead Screw Terminal |
| F = Flexible Lead Wire | S = Screw Terminal with Heavy Duty Ceramic Insulator |
| R = 90° Blockhead Screw Terminal | T = Screw Terminal with Mica Insulator |
| R1 = Flexible Armor Cable | T7 = Screw Terminal with Ceramic Insulator |

Key for Abbreviations found under the Terminal Box Type Column

- | | |
|--|--|
| C2 = Standard Box | EP = Explosion and Moisture Resistant |
| C7 = Single Box over both Heater Halves | MR1 = Moisture Proof with Perforated Shield |
| CB1 = Cast Aluminum Box | |

Key for Abbreviations found under the Cooling Termination Column

- | | |
|------------------------------|---|
| HS = Hi-Seal Fittings | RC = Non-Exposed Cooling Tubes/Recessed NPT Fittings |
|------------------------------|---|

Stock and Standard (Non-Stock) Cast-In Band Heaters for Plastics Extrusion

Stock Items Are Shown In **RED**

I.D. in	O.D. in	Length in	Material	Watts Each Half	Volts Each Half	Phase	Termination Type	Terminal Box Type	Cooling Tube	Cooling Termination	Clamping	Cast-In Heater Part Number
3.99	5.25	4.312	Brass	600	240	1	R1	None	None	None	Strap	CBH04768
4	7	7.5	Alum 319	1000	115	1	T7	None	Single	None	Strap	CBH08859
4	7.5	7.5	Alum 319	1500	190	3	S	None	Single	RC	Strap	CBH06278
4.33	8.33	6.89	Bronze	600	230	1	C4	None	None	None	Bolt	CBH10533
4.331	5.831	6.89	Alum 319	600	230	1	C4	None	None	None	Bolt	CBH08244
4.331	8.331	6.89	Bronze	1300	230	1	C4	None	None	None	Bolt	CBH11210
4.5	6	9	Alum 356	1700	230	1	T7	None	None	None	Strap	CBH08756
4.5	7	4.375	Alum 319	810	240	1	E	None	Single	None	Strap	CBH01320
4.502	7	4.375	Bronze	810	190	1	R	None	Single	None	Strap	CBH06735
4.625	7.5	4	Bronze	1000	230	1	R1A	None	Single	None	Strap	CBH07254
4.75	6	24.25	Alum 319	N/A	N/A	N/A	N/A	None	Single	None	Strap	CBH09388
5.249	8.749	13.5	Alum 319	3750	230	3	S	None	Single	None	Strap	CBH05105
5.5	6.875	13.5	Alum 356	2250	230	1	T	None	None	None	Strap	CBH08088
5.5	6.875	18	Alum 356	3000	230	1	T	None	None	None	Strap	CBH08089
5.5	7.5	3.375	Bronze	1700	240	1	S	None	None	None	Strap	CBH04614
5.5	8	4	Alum 356	750	230	1	T	None	Single	None	Strap	CBH09056
5.5	8	8	Alum 356	1500	230	1	T	None	Single	None	Strap	CBH09278
5.5	8	13.5	Alum 319	2500	240	1	T	None	Single	None	Strap	CBH07489
5.5	8.75	5.5	Bronze	1050	200	1	R	None	Single	None	Strap	CBH06201
5.5	8.75	5.5	Alum 319	1050	230	1	R	None	Single	None	Strap	CBH01023
5.5	8.75	5.5	Bronze	1400	200	1	R	None	Single	None	Strap	CBH06202
5.5	9	10.5	Alum 319	3000	200	3	C4	None	Single	RC	Strap	CBH13928
6	8.5	6	Alum 356	2000	240	1	T7	C2	Single	None	Bolt	CBH14096
6.25	9.75	13.625	Alum 319	3000	230	1	R	None	Single	None	Strap	CBH01266
6.25	10	15.875	Alum 319	5000	230	1	S	None	Single	None	Bolt	CBH01726
6.299	9.45	2.56	Bronze	1250	240	1	T	MR1	Single	None	Bolt	CBH10318
6.3	8.656	14.563	Brass	5000	220	1	C4	None	None	None	Bolt	CBH06407
6.3	8.656	18.5	Brass	4500	220	1	C4	None	None	None	Bolt	CBH06409
6.3	9.813	15.75	Alum 319	5000	240	1	C4	None	Single	RC	Strap	CBH03737
6.5	8.5	4	Alum 319	900	230	1	S	None	Single	None	Strap	CBH03964
6.5	8.5	9	Alum 356	2000	230	1	T	None	Single	None	Strap	CBH09152
6.5	9	4	Alum 356	900	230	1	T	None	Single	None	Strap	CBH09049
6.5	9	8	Alum 356	1700	230	1	T	None	Single	None	Strap	CBH09050
6.5	9	11	Alum 356	2300	240	1	T	None	Single	None	Strap	CBH09129
6.5	9	18	Alum 356	3800	240	1	T	None	Single	None	Strap	CBH07310
6.5	9.75	7.75	Bronze	1800	190	1	R	None	Single	None	Strap	CBH05840
6.5	9.75	7.75	Alum 319	1800	230	1	R	None	Single	None	Strap	CBH01066
6.5	9.75	7.75	Bronze	2200	190	1	R	None	Single	None	Strap	CBH10749
6.5	9.75	7.75	Alum 319	2500	230	1	R	None	Single	None	Strap	CBH04401
6.5	10	8.5	Alum 319	1300	240	1	T7	None	Single	RC	Strap	CBH13353
6.5	10	11	Alum 319	1685	240	1	T7	None	Single	RC	Strap	CBH13396
6.5	10	11	Alum 356	2300	240	1	T7	None	Single	None	Bolt	CBH10742
6.5	10	18	Alum 319	2755	240	1	T7	None	Single	RC	Strap	CBH13341
6.5	10	18	Alum 356	3800	240	1	T7	None	Single	None	Bolt	CBH10741
6.5	10.5	3.281	Alum 319	1000	240	1	T7	EP	None	None	Bolt	CBH11254
6.625	10.125	6	Alum 319	1550	230	1	R	None	Single	None	Strap	CBH02138
6.625	10.125	8.5	Alum 319	2200	240	1	T	None	Single	None	Strap	CBH04393
6.635	9.875	17.5	Alum 319	4360	240	1	S	None	Single	None	Bolt	CBH06070

CONTINUED



Note: Made-to-Order Manufacturing:

For sizes, ratings, terminations and/or features not listed, Tempco will manufacture a Cast-In Heater to your specifications. State quantity, watts, volts and full heater description with all the appropriate specifications and features required. See Ordering Information on page 3-63.

Customer Assistance:

If you have a special application requiring a custom manufactured Cast-In Band Heater or need assistance selecting one of our standard heaters for a new or existing installation, consult Tempco with your requirements. We offer complete engineering services and support, working with you every step of the way to ensure customer satisfaction.

Cast-In Heaters



Liquid-Cooled

Stock and Standard (Non-Stock) Cast-In Band Heaters for Plastics Extrusion

Continued from previous page...

Stock Items Are Shown In RED

I.D. in	O.D. in	Length in	Material	Watts Each Half	Volts Each Half	Phase	Termination Type	Terminal Box Type	Cooling Tube	Cooling Termination	Clamping	Cast-In Heater Part Number
6.999	10.499	18	Alum 319	6000	230	3	S	None	Single	None	Strap	CBH05138
6.999	10.499	18	Alum 319	8000	230	3	S	None	Single	None	Strap	CBH09529
7.283	8.779	8.228	Alum 319	1300	230	1	C4	None	None	None	Bolt	CBH08232
7.283	9.659	8.228	Bronze	3700	230	1	C4	None	None	None	Bolt	CBH09953
7.5	10	4	Alum 356	900	230	1	T	None	Single	None	Strap	CBH09074
7.5	10	8	Alum 356	1700	230	1	T	None	Single	None	Strap	CBH09048
7.5	10	10	Alum 319	2150	240	1	T	None	Single	None	Strap	CBH07595
7.5	10	10	Alum 356	3225	240	1	T	None	Single	None	Strap	CBH09142
7.5	10	17.5	Alum 319	3750	240	1	T	None	Single	None	Strap	CBH12380
7.5	10	17.5	Alum 356	3750	240	1	T	None	Single	None	Strap	CBH09052
7.5	10	17.5	Alum 319	5625	240	1	T	None	Single	None	Strap	CBH12089
7.5	10	17.5	Alum 356	5625	240	1	T	None	Single	None	Strap	CBH09141
7.5	10.5	6	Alum 319	1500	230	1	C4	None	Single	None	Strap	CBH04607
7.5	10.5	10.25	Bronze	2085	200	1	S	C2	Single	None	Strap	CBH09904
7.5	10.5	10.25	Alum 319	2085	230	1	S	C2	Single	None	Strap	CBH01079
7.5	10.5	10.25	Alum 319	2085	230	1	S	C2	Dual	None	Strap	CBH02414
7.5	10.5	10.25	Bronze	3000	200	1	S	C2	Single	None	Strap	CBH09906
7.5	10.5	10.25	Alum 319	3000	230	1	S	C2	Single	None	Strap	CBH03778
7.5	11	10	Alum 319	1550	240	1	T7	None	Single	RC	Strap	CBH13274
7.5	11	10	Alum 356	2150	240	1	T7	None	Single	None	Bolt	CBH10743
7.5	11	10	Alum 356	3225	240	1	T7	None	Single	None	Bolt	CBH10768
7.5	11	16.5	Alum 319	5100	230	1	R	None	Single	None	Strap	CBH02351
7.5	11	16.5	Alum 319	5100	230	1	R	None	Single	None	Strap	CBH02878
7.5	11	16.5	Alum 319	5100	230	1	R	None	Single	RC	Strap	CBH06763
7.5	11	17.5	Alum 319	2650	240	1	T7	None	Single	RC	Strap	CBH13273
7.5	11	17.5	Alum 319	3750	240	1	R	C2	Single	None	Bolt	CBH10510
7.5	11	17.5	Alum 356	3750	240	1	T7	None	Single	None	Bolt	CBH10744
7.5	11	17.5	Alum 356	5625	240	1	S	None	Single	None	Bolt	CBH10686
7.5	11	18	Alum 319	5000	230	1	S	None	Single	None	Strap	CBH07153
7.56	11	22	Alum 319	6500	230	1	S	None	Single	None	Strap	CBH06168
7.56	11.125	18	Alum 319	4950	230	1	S	None	Single	None	Strap	CBH02240
7.625	11.125	12	Alum 319	2000	240	1	S	None	Single	None	Strap	CBH09378
7.625	11.125	14.375	Alum 319	3500	230	1	R	None	Single	None	Strap	CBH01026
7.625	11.125	14.375	Alum 319	3500	240	1	R	None	Single	None	Strap	CBH01094
7.625	11.125	14.375	Alum 319	3500	460	1	R	None	Single	None	Strap	CBH01206
7.625	11.125	18	Alum 319	3500	230	1	R	None	Single	None	Strap	CBH01140
7.625	11.125	18	Alum 319	3500	230	1	R	None	Single	None	Strap	CBH01143
7.625	11.125	18	Alum 319	3500	230	1	R	None	Dual	None	Strap	CBH07322
7.71	11.25	15	Alum 319	4600	220	1	S	None	Single	None	Bolt	CBH09595
8	11	11.5	Alum 319	2000	240	1	S	None	Single	RC	Strap	CBH06630
8	11	12.75	Alum 319	2875	240	1	S	None	Single	RC	Strap	CBH06647
8	11.5	9	Alum 319	1500	240	1	R	C2	Single	RC	Bolt	CBH08236
8.005	11.5	24.375	Alum 319	4500	480	1	C4	None	Single	HS	Strap	CBH09729
8.125	11.625	9	Alum 319	1500	240	1	T7	None	Single	RC	Strap	CBH13243
8.125	11.625	14	Alum 356	3275	240	3	T7	None	Single	None	Bolt	CBH10682
8.125	11.625	20	Alum 356	4675	240	3	T7	None	Single	None	Bolt	CBH10683
8.25	11.75	13	Alum 319	5500	460	1	R	None	Single	None	Strap	CBH02460
8.25	11.75	15.75	Alum 319	7000	460	1	R	None	Single	None	Strap	CBH02245

Key for Abbreviations found under the Termination Type Column

- | | |
|---|---|
| C4 = Screw Terminal with Ceramic Cover | R1A = Stainless Steel Wire Overbraid |
| E = Right-Angle Lug | R2 = Blockhead Screw Terminal |
| F = Flexible Lead Wire | S = Screw Terminal with Heavy Duty Ceramic Insulator |
| R = 90° Blockhead Screw Terminal | T = Screw Terminal with Mica Insulator |
| R1 = Flexible Armor Cable | T7 = Screw Terminal with Ceramic Insulator |

Key for Abbreviations found under the Terminal Box Type Column

- | | |
|--|--|
| C2 = Standard Box | EP = Explosion and Moisture Resistant |
| C7 = Single Box over both Heater Halves | MR1 = Moisture Proof with Perforated Shield |
| CB1 = Cast Aluminum Box | |

Key for Abbreviations found under the Cooling Termination Column

- | | |
|------------------------------|---|
| HS = Hi-Seal Fittings | RC = Non-Exposed Cooling Tubes/Recessed NPT Fittings |
|------------------------------|---|



Stock and Standard (Non-Stock) Cast-In Band Heaters for Plastics Extrusion

Stock Items Are Shown In **RED**

I.D. in	O.D. in	Length in	Material	Watts Each Half	Volts Each Half	Phase	Termination Type	Terminal Box Type	Cooling Tube	Cooling Termination	Clamping	Cast-In Heater Part Number
8.268	11.768	21.457	Alum 319	7500	220	3	C4	None	Single	RC	Strap	CBH03794
8.5	12	8.75	Alum 319	2900	460	1	T7	None	Single	None	Strap	CBH07043
8.5	12	8.75	Alum 319	3000	230	1	R	None	Single	None	Strap	CBH01444
8.51	11.75	18.25	Alum 319	5900	240	3	S	None	Single	None	Bolt	CBH06068
8.661	12.244	11.024	Alum 319	3400	230	1	R1A	None	Single	RC	Bolt	CBH11606
8.666	12.25	11.625	Alum 319	3400	240	1	R1A	None	Single	RC	Bolt	CBH07586
9	12.5	12.5	Alum 319	3750	240	1	C4	None	Single	RC	Bolt	CBH09779
9.05	12.55	15.98	Alum 319	5600	230	1	R1A	None	Single	RC	Bolt	CBH08396
9.055	12.563	16	Alum 319	5750	220	1	S	None	Single	None	Bolt	CBH09999
9.312	12.625	11	Alum 319	3750	230	1	C4	None	Dual	RC	Strap	CBH07949
9.312	12.625	11	Alum 319	3750	230	1	S	C2	Single	None	Strap	CBH01108
9.313	12.625	11	Alum 319	3750	230	1	R	None	Single	None	Strap	CBH01273
9.313	12.625	11	Alum 319	4950	230	1	S	C2	Single	None	Strap	CBH01133
9.5	12	12	Alum 319	3900	230	1	T7	None	Single	None	Strap	CBH12118
9.5	12	12	Alum 356	3900	230	1	T	None	Single	None	Strap	CBH09221
9.5	12	12	Bronze	3900	230	1	T	None	Single	None	Strap	CBH11491
9.5	12	16	Alum 356	5150	240	1	T	None	Single	None	Strap	CBH09126
9.5	12	24.5	Alum 356	7850	240	1	T	None	Single	None	Strap	CBH09127
9.5	12	24.5	Brass	11750	240	1	T7	None	Single	RC	Strap	CBH08350
9.5	13	8.5	Alum 319	4000	288	1	R	None	Single	RC	Bolt	CBH12533
9.5	13	11.5	Alum 319	2575	240	1	T7	None	Single	RC	Strap	CBH13354
9.5	13	13	Alum 319	5250	460	3	S	None	Single	None	Bolt	CBH08749
9.5	13	16	Alum 319	3580	240	1	T7	None	Single	RC	Strap	CBH13342
9.5	13	16	Alum 356	5150	240	3	T7	None	Single	None	Bolt	CBH10746
9.5	13	16	Alum 356	5150	240	1	T7	None	Single	None	Bolt	CBH10767
9.5	13	16	Alum 356	7750	240	1	T7	None	Single	None	Bolt	CBH10688
9.5	13	20.25	Alum 319	7500	240	1	C4	None	Single	RC	Bolt	CBH12958
9.5	13	24.5	Alum 319	5485	240	1	T7	None	Single	RC	Strap	CBH13371
9.5	13	24.5	Alum 356	7850	240	1	T7	None	Single	None	Bolt	CBH10689
9.5	13	24.5	Alum 356	7850	240	3	T7	None	Single	None	Bolt	CBH10745
9.5	13	24.5	Alum 356	11750	240	1	T7	None	Single	None	Bolt	CBH10690
9.5	13	27.75	Alum 319	12000	230	3	S	None	Single	None	Bolt	CBH01528
9.5	13	27.75	Alum 319	12000	230	3	S	None	Dual	None	Strap	CBH08104
9.75	12.75	24	Alum 319	9185	240	1	S	None	Single	None	Strap	CBH02183
9.75	13.25	9	Alum 319	3100	230	1	R	None	Single	None	Strap	CBH01532
9.75	13.25	11	Alum 319	3500	230	1	R	None	Single	None	Strap	CBH02461
9.75	13.25	11	Alum 319	3500	250	1	R	None	Single	None	Strap	CBH02692
9.75	13.25	11	Alum 319	4500	230	1	R	None	Single	RC	Strap	CBH03873
9.75	13.25	12	Alum 319	4500	230	1	R	None	Single	None	Strap	CBH01453
9.75	13.375	19.438	Alum 319	6000	230	1	R	None	Single	None	Strap	CBH01144
9.75	13.375	19.438	Alum 319	6000	230	1	S	None	Single	None	Strap	CBH01221
9.75	13.375	23.875	Alum 319	6000	230	1	R	None	Single	None	Strap	CBH01077
9.76	13	12.25	Alum 319	5000	240	3	S	None	Single	None	Bolt	CBH06069
9.842	12.188	13.375	Brass	3500	220	1	C4	None	None	None	Bolt	CBH06408
9.875	13	8.5	Alum 319	2000	240	1	E	None	Single	RC	Strap	CBH06648
9.875	13	12.25	Alum 319	4500	240	1	S	None	Single	RC	Strap	CBH06094
9.875	13.375	8.5	Alum 319	2000	240	1	R	C2	Single	RC	Bolt	CBH08955
10	13.5	12	Alum 319	6480	230	3	S	None	Single	None	Strap	CBH05102



Made-to-Order Manufacturing

For sizes, ratings, terminations and/or features not listed, Tempco will manufacture a Cast-In Heater to your specifications. State quantity, watts, volts and full heater description with all the appropriate specifications and features required. See Ordering Information on page 3-63.

Customer Assistance

If you have a special application requiring a custom manufactured Cast-In Band Heater or need assistance selecting one of our standard heaters for a new or existing installation, consult Tempco with your requirements. We offer complete engineering services and support, working with you every step of the way to ensure customer satisfaction.

Cast-In Heaters



Liquid-Cooled

Stock and Standard (Non-Stock) Cast-In Band Heaters for Plastics Extrusion

Continued from previous page...

Stock Items Are Shown In **RED**

I.D. in	O.D. in	Length in	Material	Watts Each Half	Volts Each Half	Phase	Termination Type	Terminal Box Type	Cooling Tube	Cooling Termination	Clamping	Cast-In Heater Part Number
10	13.5	12	Bronze	6480	230	3	S	None	Single	None	Strap	CBH08755
10	13.5	12	Alum 319	6480	240	3	S	None	Dual	RC	Strap	CBH07168
10	13.5	12	Alum 319	6480	290	3	S	None	Single	None	Strap	CBH05120
10.03	13.53	24.9	Alum 319	6000	480	1	C4	None	Single	RC	Strap	CBH06260
10.039	13.535	13	Alum 319	6000	220	3	C4	None	Single	RC	Strap	CBH04378
10.236	11.438	6.313	Alum 319	N/A	N/A	N/A	N/A	None	Single	None	Strap	CBH09288
10.5	14	10	Alum 319	2900	240	1	T7	None	Single	RC	Strap	CBH13499
10.5	14	21	Alum 356	11500	240	3	T7	None	Single	None	Bolt	CBH10685
10.625	12.625	10.5	Bronze	7000	480	3	T7	Rose	None	None	Strap	CBH07880
11.024	14.606	13.976	Alum 319	6050	230	1	R1A	None	Single	RC	Bolt	CBH08121
11.024	14.606	14.252	Alum 319	6250	230	1	R1A	None	Single	RC	Bolt	CBH11237
11.41	14.92	7.48	Alum 319	3313	230	1	R1A	None	Single	RC	Bolt	CBH08394
11.41	14.92	12.28	Alum 319	5425	230	1	R1A	None	Single	RC	Bolt	CBH08395
11.5	14.75	11.625	Alum 319	4700	230	1	S	C2	Single	None	Strap	CBH01136
12	15.5	11.5	Alum 319	4500	240	1	C4	None	Single	RC	Strap	CBH09363
12.25	16.5	12.25	Alum 319	5500	230	1	S	None	Dual	None	Bolt	CBH06827
12.25	16.5	12.25	Alum 319	5500	230	1	S	None	Dual	RC	Bolt	CBH12665
12.5	16	11	Alum 319	7500	460	1	T7	C2	Single	RC	Strap	CBH10490
12.5	16	14	Alum 319	7500	460	1	T7	C2	Single	RC	Strap	CBH10489
12.5	16	14	Bronze	10000	460	1	S	None	Single	None	Strap	CBH02869
12.5	16	15	Alum 319	8750	240	1	R	None	Single	None	Strap	CBH01731
12.5	16	28	Alum 319	15000	480	3	S	None	Single	RC	Bolt	CBH07693
12.598	13.85	9.449	Alum 319	N/A	N/A	N/A	N/A	None	Single	None	Strap	CBH09287
12.598	16.181	16.653	Alum 319	8400	230	1	R1A	None	Single	RC	Bolt	CBH08122
12.996	16.5	13.75	Alum 319	6750	460	1	R	None	Single	None	Strap	CBH10840
13.5	17.25	26.5	Alum 319	10000	460	1	R	None	Single	HS	Strap	CBH01685
14	17.5	13.75	Alum 319	6250	240	1	C4	None	Single	RC	Bolt	CBH14211
14.567	18.189	17.874	Alum 319	10500	460	3	T7	Rose	Single	RC	Bolt	CBH10043
15	18.5	10	Alum 319	5500	240	1	S	None	Dual	None	Strap	CBH03477
15.354	17.354	4	Bronze	3000	240	1	R1A	CB1	None	None	Bolt	CBH08619
15.354	17.354	6	Bronze	3500	240	1	R1A	CB1	None	None	Bolt	CBH08618
15.75	17.75	2.5	Bronze	2800	240	1	T7	EP	None	None	Strap	CBH09753
16.142	18.142	7.875	Alum 319	6875	480	3	R1A	None	None	None	Strap	CBH10563
20.669	22.669	2	Alum 319	2500	220	1	S	C7	None	None	Strap	CBH04057
27	30	4	Alum 319	5000	480	1	E	Rose	None	None	Strap	CBH06807

Made-to-Order Manufacturing

For sizes, ratings, terminations and/or features not listed, Tempco will manufacture a Cast-In Heater to your specifications. State quantity, watts, volts and full heater description with all the appropriate specifications and features required. See Ordering Information on page 3-63.

Customer Assistance

If you have a special application requiring a custom manufactured Cast-In Band Heater or need assistance selecting one of our standard heaters for a new or existing installation, consult Tempco with your requirements. We offer complete engineering services and support, working with you every step of the way to ensure customer satisfaction.

Key for Abbreviations found under the Termination Type Column

C4 = Screw Terminal with Ceramic Cover	R1A = Stainless Steel Wire Overbraid
E = Right-Angle Lug	R2 = Blockhead Screw Terminal
F = Flexible Lead Wire	S = Screw Terminal with Heavy Duty Ceramic Insulator
R = 90° Blockhead Screw Terminal	T = Screw Terminal with Mica Insulator
R1 = Flexible Armor Cable	T7 = Screw Terminal with Ceramic Insulator

Key for Abbreviations found under the Terminal Box Type Column

C2 = Standard Box	EP = Explosion and Moisture Resistant
C7 = Single Box over both Heater Halves	MR1 = Moisture Proof with Perforated Shield
CB1 = Cast Aluminum Box	

Key for Abbreviations found under the Cooling Termination Column

HS = Hi-Seal Fittings	RC = Non-Exposed Cooling Tubes/Recessed NPT Fittings
------------------------------	---

Cast-In Band Heater Ordering Information

Cast-In Band Heater Strap Clamping

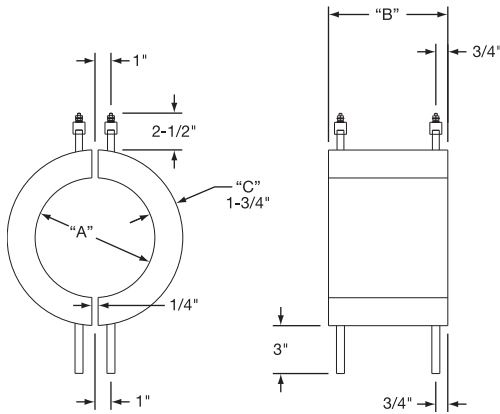

Cast-In Band Heater Bolt Clamping

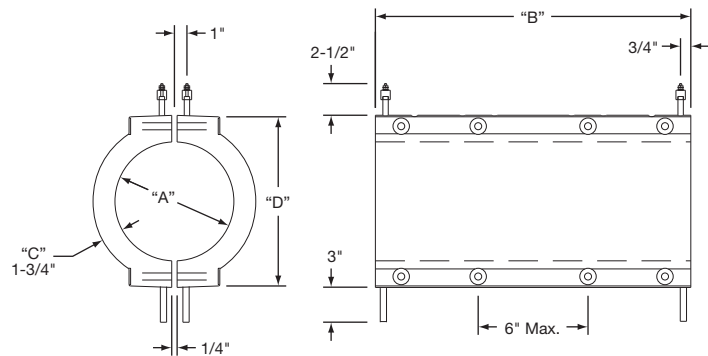

Recommended dimensions shown.

Ordering Information

To process your order or quotation, please specify the following information.

Variable Dimensions

Inside Diameter "A" _____ Length "B" _____ Thickness "C" _____ "D" _____

Material Specifications

Aluminum Bronze Brass

Electrical Specifications

Watts each half _____ Volts each half _____ Phase _____

Terminal Style

"S" Post Terminals "C4" Ceramic Cover "F" Plain Leads
 "R" 90° Blockhead "T7" Post Terminals "MR" Moisture Resistant
 "E" Right-Angle Lugs "T" Post Terminals "TS" Leads and Shrink Sleeve
 "R1" Armor Cable Leads "R1A" SS Wire Overbraid
 "R2" Blockhead and Through Hole See Pages 3-54 and 3-55 for additional Terminations

Terminal Protection Box

None "C2" Standard "C7" 1 Box for both halves "EP" Explosion Resistant
 "P2" High Temperature Quick-Disconnect "MPR" Moisture Resistant Box
 "MR1" Rigid Moisture Resistant Box "CB1" Cast Aluminum Box

Clamping Style

Straps Bolt Clamp

Cooling Tube Specifications

1/4" O.D. SS 3/8" O.D. SS 1/2" O.D. SS
 3/8" O.D. Incoloy® 1/2" O.D. Incoloy® Dual Cooling Tubes
 Standard Wall Thickness Other Wall Thickness, Specify _____
 (See page 3-5 for Standard Wall Thickness Information)

Cooling Tube Fittings

Non-exposed 3/8" NPTF "HS" Hi-Seal Fitting "RA" 90° Copper Elbow
 Non-exposed 1/2" NPTF "RT" 90° Threaded Elbow
 "FF" Flared Seal "R3" Straight Threaded

Surface Finish

125 RMS Standard or to Customer Specifications

Special Cast-In Features

Holes, Cutouts, Slots, Bevels, Mounting Studs, Stand-Offs and Taper Angles
For special features a detailed drawing is required.

⚠ WARNING: Cancer and Reproductive Harm - www.P65Warnings.ca.gov.

“L” Shaped

“L” Shaped Bronze, Brass or Aluminum Cast-In Heaters for Square and Rectangular Extruder Barrels

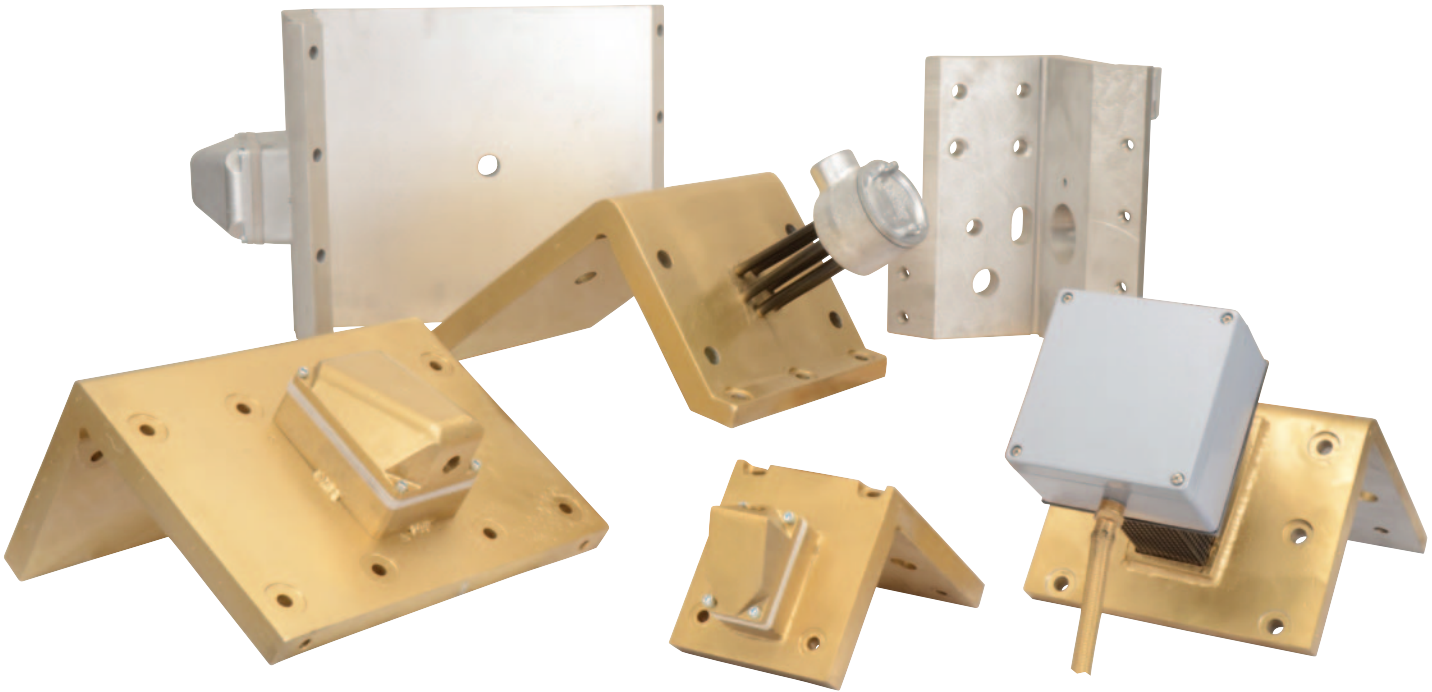

Cast-In Heaters That Provide High Temperature and Maximum Processing Capabilities

The “L” Shaped Cast-In Heaters are typically used on square and rectangular twin screw extruder barrels in compounding and plastic resin manufacturing applications. Due to high shear rates, which are common in this process, extreme operating temperatures and high watt densities are frequently encountered. For these reasons Tempco manufactures “L” shaped heaters in bronze or brass alloys, which are capable of withstanding high temperatures at higher watt densities.

In the case of applications requiring lower temperatures and lower watt densities, aluminum alloys can be used. Aluminum castings are desirable as they have greater thermal conductivity and weigh substantially less than their bronze or brass counterparts, allowing for greater ease of installation.

For mounting purposes, the heaters can be designed with 45° flanged ear extensions that are bolted and drawn together, or can be made with through holes machined into the casting body to bolt directly onto the barrel itself. Thermocouple and transducer holes or other special features can be accommodated as well.

To enhance cooling capabilities, or to be used in place of integral feed screw cooling, “L” shaped heaters can be manufactured with cast-in cooling tubes to satisfy liquid cooling requirements. This feature allows processors the ease of changing a single unit at a time, thus representing a far less time-consuming and less expensive alternative should a cooling line become clogged or severely restricted.

Enhanced Features

To aid processors in reducing maintenance downtime, Tempco has introduced several optional construction features to the basic “L” shaped design.

- * *Cast-In Aluminum Alloys for applications requiring lower temperatures and less watt density*
- * *3/8" or 1/2" O.D. cooling tubes for liquid cooling*
- * *Non-Exposed cooling tubes (Type RC—See page 3-51). Eliminates cracked and broken cooling tubes.*



Note: All of the options listed above are design enhancements that will provide value-added benefits to the basic “L” shape configuration, thereby extending the life and performance of your Cast-In Heaters.

Standard “L” Shaped Cast-In Heaters

Design Features

- * *Cast-In Bronze or Brass Alloys for high temperature, high shear applications*
- * *Flange bolt clamping arrangement or through holes in the heater body, allowing bolt mounting directly to the barrel*
- * *High precision machining of the inner contact surface of the heater, yielding exceptional heat transfer to the process*
- * *Choice of terminal protection housings*
- * *Moisture resistant terminal housing which is available in a variety of different styles and mounting arrangements*
- * *Elevated temperature terminations and enclosures. Prevents premature heater failure due to accelerated corrosion or oxidation of terminals caused by high heater surface temperature. See page 3-66 and 3-67 for details on how to order.*

Standard (Non-Stock) "L" Shaped Cast-In Heaters

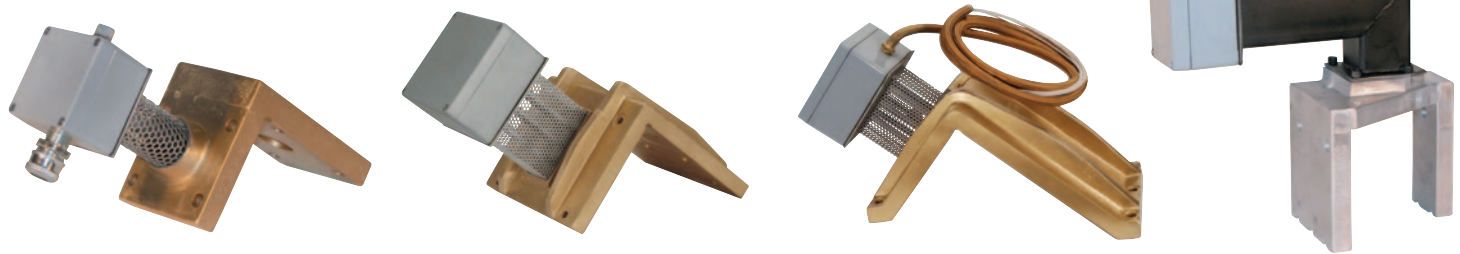

"L" Shaped Bronze, Brass or Aluminum Cast-In Heaters are sold as individual units. They are normally supplied with a moisture resistant junction box. Also available with explosion resistant or cast-on junction box, fitted with convoluted wire braided hose and high temperature lead wire. If required, specify. For additional terminations, see pages 3-54 and 3-55.

The sizes and ratings listed are among the most commonly used. They will provide the shortest lead times.

Long Leg (in)	Short Leg (in)	Width in	Thickness in	Watts	Volts	Special Features	Part Number
3.500	2.500	3.500	0.875	500	240	Cast terminal box, (3) .397" dia. holes, (1) 5/8" dia. cutout, Bronze	CBH05817
3.500	2.500	3.500	0.875	500	240	Cast terminal box, (3) .397" dia. holes, Bronze	CBH05818
3.500	2.500	7.000	0.875	1000	240	Cast terminal box, (6) .397" dia. holes, Bronze	CBH05819
2.500	1.550	1.750	0.500	300	120	(1) 1/2" long slot, R1, Hubbell® plug, Aluminum	CBH04036
2.500	1.550	1.750	0.500	300	120	(1) 1/8" NPT hole, (1) 1/2" long slot, Bronze	CBH04103
3.460	2.680	4.330	1.181	500	220	MPR terminal box, (1) 25 mm dia. hole, (4) 9 mm dia. holes, Aluminum	CBH04926
3.460	2.680	4.330	1.181	500	220	MPR terminal box, (1) 25 mm dia. hole, (4) 9 mm dia. holes, Aluminum	CBH04922
3.460	2.760	4.330	1.181	500	220	MPR terminal, (1) 25 mm dia. hole, (8) 9 mm dia. holes, Aluminum	CBH04929
3.937	3.465	4.331	1.181	500	230	MPR terminal, 3/8" NPT RA elbow C/T, Brass	CBH04045
4.173	3.071	4.310	1.000	900	240	Cast terminal box, (2) 1/2" dia. holes, (2) 1/2" dia. cutouts, Bronze	CBH01617
4.173	3.346	4.921	1.575	2000	230	MPR, (1) 25 mm dia. hole, Brass	CBH04295
4.724	3.248	4.921	1.575	1500	230	MPR terminal box, (1) 25 mm dia. hole, Brass	CBH04290
4.823	3.346	4.921	1.575	2000	230	MPR terminal box, (1) 25 mm dia. hole, Brass	CBH04294
6.000	4.449	6.417	1.000	2000	240	Cast terminal box, (4) 1/2" dia. holes, (2) 1" long cutouts, Bronze	CBH01618
6.140	4.311	7.480	0.750	2500	240	Cast terminal box, (5) 1/2" dia. holes, (2) 1/2" dia. cutouts, Bronze	CBH01971
6.180	4.215	6.690	1.000	3000	240	Cast terminal box, (5) 1/16" dia. holes, (2) 1" dia. cutouts, Bronze	CBH02140
6.188	4.313	1.000	1.000	1500	240	Cast terminal box, (1) 1" dia. hole, (4) 1/4" dia. holes, Bronze	CBH01619
7.756	11.693	14.961	1.970	4500	460	MPR terminal box, (6) .394" dia. holes, Aluminum	CBH05011
7.813	5.188	10.625	1.000	5250	480	Cast terminal box, (8) 1/16" dia. holes, Bronze	CBH03042
7.830	5.220	10.63	0.980	3500	480	Cast terminal box, (8) 1/16" dia. holes, Bronze	CBH02114
7.874	6.102	10.394	1.000	4200	480	Cast terminal box, (6) 1/16" dia. holes, Bronze	CBH01692
7.874	6.102	10.394	1.000	4200	480	Cast terminal box, (6) 1/16" dia. holes, Bronze	CBH01839
8.500	6.140	2.750	0.750	1200	240	Cast terminal cover, (1) 1" dia. hole, (2) 1/2" dia. holes, Bronze	CBH01725
8.500	6.140	7.480	0.750	5250	240	Cast terminal box, (6) 1/2" dia. holes, (2) 7/8" dia. holes, Bronze	CBH02124
8.890	5.945	6.420	1.000	3000	240	Cast terminal box, (6) 1/2" dia. holes, (1) 1" dia. hole, Bronze	CBH01550
9.055	4.684	2.362	0.591	750	240	13" Cable, 18" leads, (5) .413" dia. holes, Aluminum	CBH04591
9.134	6.000	7.480	1.000	3500	240	Cast terminal box, (4) 1/2" dia. holes, Bronze	CBH05352
9.173	6.181	10.630	1.772	5000	230	MPR terminal box, (8) .472" dia. holes, (1) 1" dia. hole, Brass	CBH03940
9.449	7.756	14.330	1.102	6800	277	Cast terminal box, 3-Ph, (8) 1/16" dia. holes, Bronze	CBH01667
9.449	7.756	14.330	1.102	6800	575	Cast terminal box, 3-Ph, (4) 1/2" dia. holes, (4) 1/16" dia. holes, Bronze	CBH01709
10.563	7.813	10.625	1.000	8800	480	Cast terminal box, 3-Ph, (8) 1/16" dia. holes, Bronze	CBH03041
10.590	7.830	10.630	1.000	5500	480	Cast terminal box, 3-Ph, (8) 1/16" dia. holes, Bronze	CBH02113
10.830	4.684	2.362	0.591	870	240	MPR terminal box, (5) .413" dia. holes, Aluminum	CBH04594
11.690	7.756	14.960	1.969	9000	460	MPR term. box, (8) .393" & (1) .984" dia holes, Al., Heat & Cool	CBH05012
11.690	7.756	14.960	1.968	N/A	N/A	(12) .393" dia. holes, (1) .984" dia. hole, Aluminum	CBH05013
11.690	7.760	14.960	1.969	9000	460	MPR terminal box, (10) .393" dia. holes, Aluminum	CBH05014
12.188	7.875	10.375	1.000	8100	480	Cast terminal box, (6) 1/16" dia. holes, Bronze	CBH04408
12.205	7.875	4.134	1.000	3000	240	Cast terminal box, (4) 1/16" dia. holes, (1) 7/8" dia. cutout, Bronze	CBH01756
12.205	7.875	10.394	1.000	6260	480	Cast terminal box, (6) 1/16" dia. holes, Bronze	CBH02144
15.712	13.000	9.250	1.250	5500	220	(6) 1/2" dia. holes, (1) 7/8" hole, Bronze	CBH05037
18.110	9.169	4.530	0.591	3030	240	(10) .493" dia. holes, 20" cable, 27" leads, Aluminum	CBH04593
18.110	9.169	4.530	0.591	3030	240	MPR terminal box, (10) .430" dia. holes, Aluminum	CBH04596

Key for Abbreviations found under the Features Column

- E/H = Each Half
- EP = Explosion Resistant Terminal Housing
- MR = Moisture Resistant Terminal Housing
- MPR = Moisture Proof Die Cast Aluminum Box
- C/T = Cooling Tubes
- CW = Single Set of Cooling Tubes
- CWW = Dual Set of Cooling Tubes
- RC = Non-Exposed Cooling Tubes/Recessed NPT Fittings

Ordering Information

"L" Shaped Cast-In Heaters – 45° Flange Mount Style Ordering Information

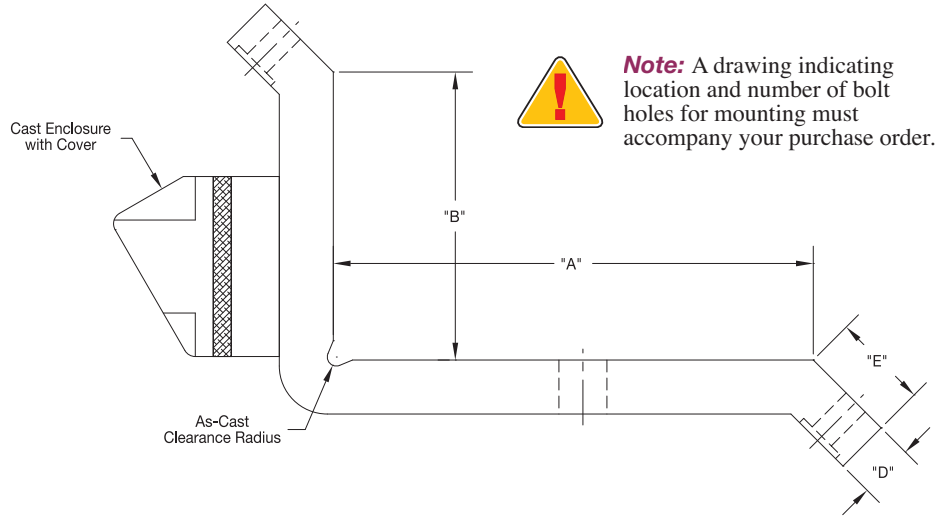
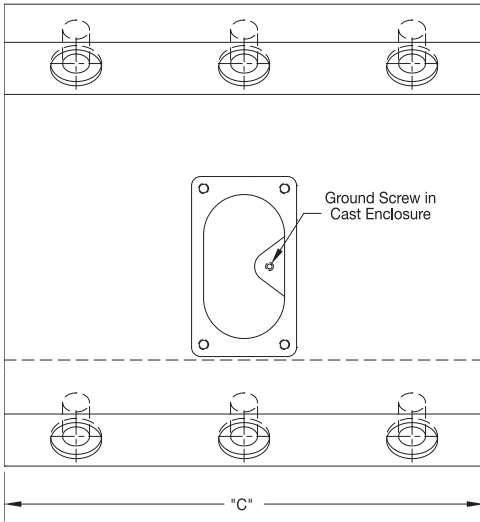

"L" Shaped Cast-In Heaters — 45° Flange Mount Style

Dimensions

"A" _____ "B" _____ "C" _____
 "D" _____ "E" _____

Ordering Information

To process your order or quotation, please specify the following information.

Material Specifications

Aluminum Bronze Brass

Electrical Specifications

Watts each piece _____ Volts each piece _____ Phase _____

Termination Style

"S" Post Terminals "T7" Post Terminals "T" Post Terminals
 "R1" Armor Cable Leads "E" Right Angle Lugs

Terminal Protection Box

None "C2" Standard Cast on box as shown
 "EP" Explosion Resistant "MR1" Rigid Moisture Resistant Box
 "MPR" Moisture Resistant Box "P2" High Temperature Quick Disconnect

Clamping Style

Bolt Clamp Other

Cooling Tube Specifications

1/4" O.D. SS 3/8" O.D. SS 1/2" O.D. SS
 3/8" O.D. Incoloy® 1/2" O.D. Incoloy® Dual Cooling Tubes
 Standard Wall Thickness Other Wall Thickness, Specify _____
 (See page 3-5 for Standard Wall Thickness Information)

Cooling Tube Fittings

Non-exposed 3/8" NPTF "HS" Hi-Seal Fitting "RA" 90° Copper Elbow
 Non-exposed 1/2" NPTF "RT" 90° Threaded Elbow
 "FF" Flared Seal "R3" Straight Threaded

Surface Finish

125 RMS Standard or to Customer Specifications

Special Cast-In Features

Holes, Cutouts, Slots, Bevels, Mounting Studs, Stand-Offs and Taper Angles.
For special features a detailed drawing is required.

WARNING: Cancer and Reproductive Harm - www.P65Warnings.ca.gov.

"L" Shaped Cast-In Heaters Bolt Direct to Barrel Style Ordering Information

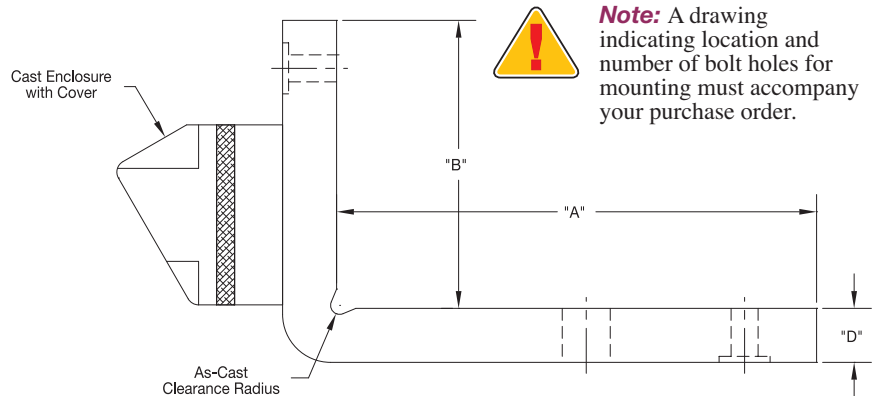
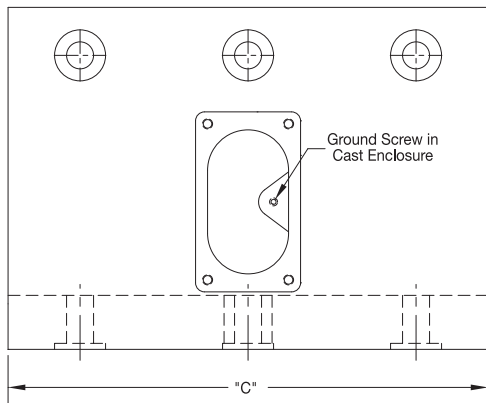

Note: A drawing indicating location and number of bolt holes for mounting must accompany your purchase order.

"L" Shaped Cast-In Heaters Bolt Direct to Barrel Style

Dimensions

"A" _____ "B" _____ "C" _____
 "D" _____

Ordering Information

To process your order or quotation, please specify the following information.

Material Specifications

Aluminum Bronze Brass

Electrical Specifications

Watts each piece _____ Volts each piece _____ Phase _____

Termination Style

"S" Post Terminals "T7" Post Terminals "T" Mica Washers
 "R1" Armor Cable Leads "E" Right-Angle Lugs

Terminal Protection Box

None "C2" Standard Cast on box as shown
 "EP" Explosion Resistant "MR1" Rigid Moisture Resistant Box
 "MPR" Moisture Resistant Box "P2" High Temperature Quick Disconnect

Clamping Style

Bolt Clamp Other

Cooling Tube Specifications

1/4" O.D. SS 3/8" O.D. SS 1/2" O.D. SS
 3/8" O.D. Incoloy® 1/2" O.D. Incoloy® Dual Cooling Tubes
 Standard Wall Thickness Other Wall Thickness, Specify _____
 (See page 3-5 for Standard Wall Thickness Information)

Cooling Tube Fittings

Non-exposed 3/8" NPTF "HS" Hi-Seal Fitting "RA" 90° Copper Elbow
 Non-exposed 1/2" NPTF "RT" 90° Threaded Elbow
 "FF" Flared Seal "R3" Straight Threaded

Surface Finish

125 RMS Standard or to Customer Specifications

Special Cast-In Features

Holes, Cutouts, Slots, Bevels, Mounting Studs, Stand-Offs and Taper Angles.
For special features a detailed drawing is required.

⚠ WARNING: Cancer and Reproductive Harm - www.P65Warnings.ca.gov.

Cast-In Heaters



Ring-Shaped

Cast-In Aluminum or Bronze Ring Heaters for Plastics Processing Equipment

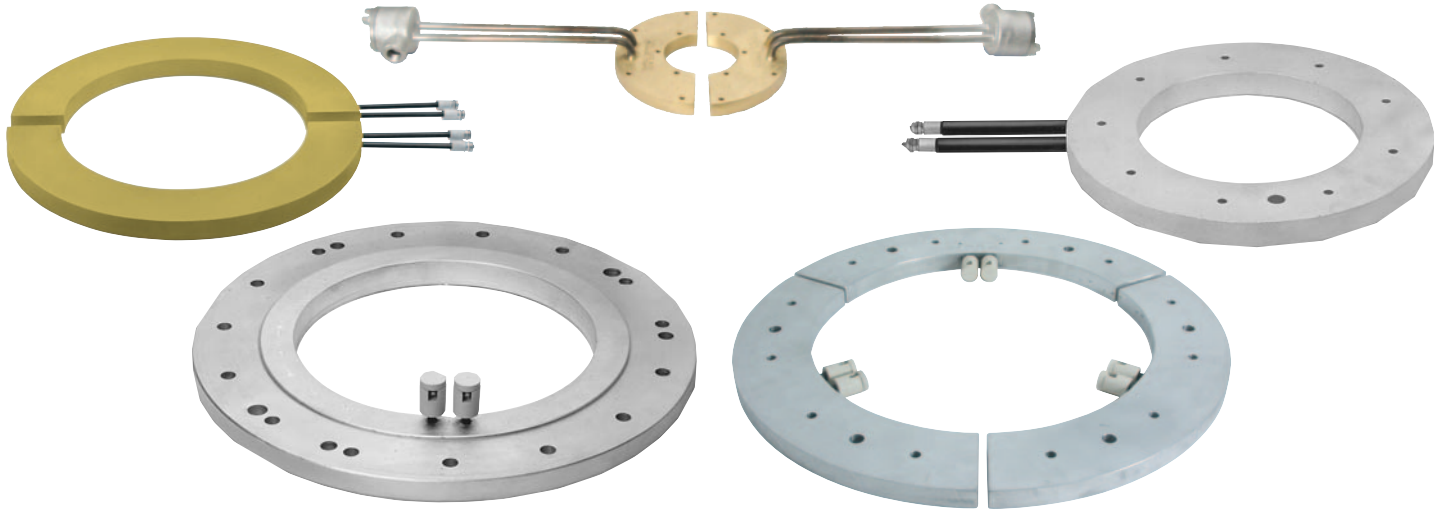

Designed to Heat Limited Access Locations

Tempco Cast-In Ring Heaters provide an excellent means of applying extremely uniform heat to limited access application areas. Cast-In Ring Heaters are frequently used in Blown Film Die, Extrusion Die, Screen Changer and Extruder Barrel Adapter applications where long life and minimal maintenance concerns are prevalent.

The design scope of this product line makes it possible to cast large or small diameter disc shaped rings with nominal thicknesses of 5/8" to 1". These units are an excellent choice for heating the top or bottom of a cylindrical die.

As a standard, Cast-In Ring Heaters are generally manufactured in aluminum because of its superior thermal conductivity. For higher temperature or high watt density requirements, bronze or brass alloys can be used. A variety of standard terminations shown on pages 3-54 and 3-55 are available. The units can be fully machined to include through holes for mounting, thermocouple holes and surface machining.

Standard Cast-In Ring Heaters

Design Features and Options:

- * Computer designed, precisely formed tubular heating element optimizing the heat transfer pattern
- * Variety of termination options including terminal enclosure housings
- * Variety of shapes and sizes
- * Through holes, tapped holes or cutouts to facilitate mounting or obstructions
- * Precision machining of one or all surfaces of casting – specify your individual requirements.

CUSTOM Manufactured

For sizes and ratings not listed, **TEMPCO** will design and manufacture a Cast-In Ring Heater to meet your requirements. **Specify the following:**

- Inside Diameter
- Outside Diameter
- Thickness
- Wattage and Voltage
- Number of Segments
- Termination Type (see pages 3-54 and 3-55)
- Alloy (Aluminum or Bronze)
- Special Features
- Machining Specifications
- Detailed Drawing

Stock and Standard (Non-Stock) Cast-In Ring Heaters

Stock Items Are Shown In **RED**

I.D. in	O.D. in	Thickness in	Watts	Volts	Special Features	Part Number
5.500	14.000	1.000	2250	230	(8) 1/2" dia. holes	CBH02625
6.750	11.750	1.000	1250	480	(4) 1/16" dia. holes E/H	CBH05499
7.000	11.500	0.875	3200	240	(9) 3/2" dia. holes	CBH01084
7.000	11.500	0.875	3200	460	(9) 3/16" dia. holes, (1) 1/2" dia. hole	CBH05415
8.500	13.000	1.000	3000	230	(8) 3/2" dia. holes	CBH01101
10.000	14.500	0.875	4000	230	(8) 3/2" dia. hole, (8) 1/2" c'bore	CBH01196
10.000	14.500	0.875	1000	230	(2) 90° Segments	CBH01085
12.000	16.250	0.875	2125	230	Bronze	CBH01261
12.000	16.250	0.875	2125	230	Bronze	CBH04776
13.000	20.000	1.120	2025	460	(4) 1/16" dia. holes E/H, (2) 1/2"-13 taps	CBH04836
16.250	20.500	1.000	1500	480	(6) 1/16" dia. holes	CBH04943
17.000	20.000	1.500	1250	230	(4) 90° Segments	CBH04990
19.750	34.000	1.130	4000	460	(12) 1/16" dia. holes, (2) 1/2"-13 taps	CBH04837
23.000	29.000	1.000	2000	480	(8) 1/32" dia. holes, (1) 5/8" dia. hole	CBH04220
32.500	40.000	1.125	9000	460	(24) 3/8" dia. holes	CBH02235
43.250	56.250	1.125	4333	290	(16) 1/16" dia. holes	CBH02811



Note: Part numbers are for aluminum heaters unless otherwise specified.

WARNING: Cancer and Reproductive Harm - www.P65Warnings.ca.gov.

Cast-In Cross Head Die Heaters for Plastics Extrusion Processing Equipment

Maximize Service Life on Difficult Extrusion Die Applications

Extrusion Cross Head and related extrusion dies present extremely challenging operating parameters to most conventional heating elements. This is primarily due to the presence of excessive contamination, high watt densities and high temperature as well as unusual physical and dimensional requirements.

Many processors continue to use ceramic and mica band heaters on this application, with frequently marginal results. In these instances, Cast-In Aluminum or Bronze heaters are recommended to substantially improve heater life expectancy and performance.

Cast-In Heaters are less susceptible to contamination problems, and can operate at higher temperatures with higher watt densities. In addition, the design is structurally better suited to accommodate holes and cutouts without compromising the heater's electrical and mechanical integrity.

As a standard, Cross Head Die Heaters are typically designed in aluminum as a one-piece band with a single slot that can be slid over the die and clamped with stainless steel clamping straps. For higher temperature or high watt density requirements, bronze or brass alloys can be used.

CUSTOM Manufactured

For sizes and ratings not listed, **TEMPCO** will design and manufacture a Cross Head Die Heater to meet your requirements.

Specify the following:

- Inside Diameter
- Outside Diameter
- Thickness
- Wattage and Voltage
- Termination Type (see pages 3-54 and 3-55)
- Alloy (Aluminum or Bronze)
- Special Features
- Machining Specifications
- Detailed Drawing

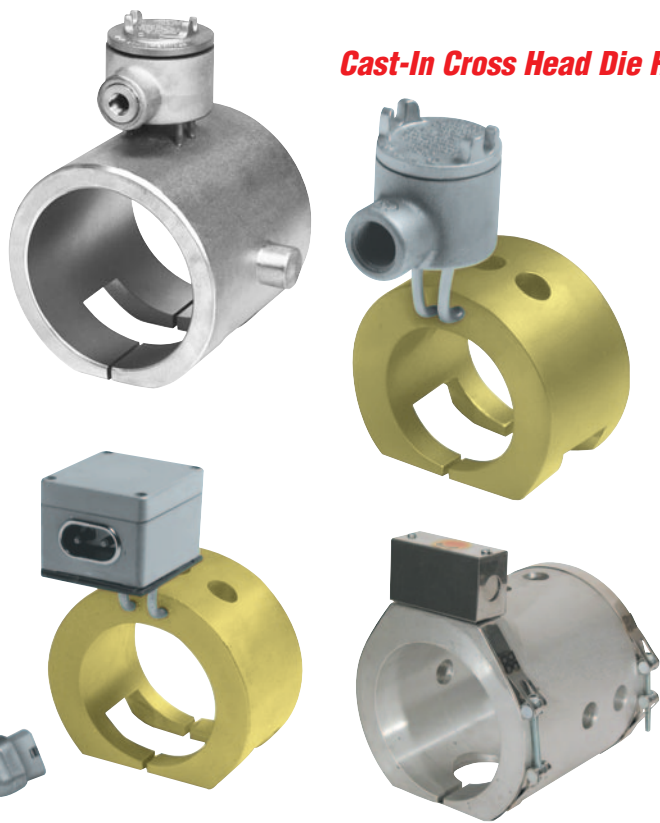

Standard Cross Head Die Heaters Design Features and Options:

- * Computer designed, precisely formed tubular heating element, optimizing the heat transfer pattern.
- * Variety of termination options, including terminal enclosure housings.
- * Optional 1/4", 3/8" or 1/2" cooling tubes cast into the cross head die body for liquid cool function.
- * Variety of shapes and sizes.
- * Aluminum and bronze alloys.
- * Through holes, tap holes or cutouts to facilitate mounting or obstructions.
- * Precision machining of one or all surfaces of casting – specify your individual requirements.



Note: Part numbers are for aluminum heaters unless otherwise specified.

Stock and Standard (Non-Stock) Cross Head Die Cast-In Heaters (Stock Items Are Shown In RED)

I.D. in	O.D. in	Length in	Thickness in	Watts	Volts	Special Features	Part Number
2.500	4.000	2.625	0.750	750	240	Bronze, (3) 5/8" dia. holes, C7 terminal box	CBH01913
3.000	4.500	4.000	0.750	1200	240	Bronze, (3) 3/4" dia. holes, 2" dia. cutout, R1 cable 70", 72" leads	CBH02634
3.248	5.248	3.000	1.000	750	230	(3) 3/4" dia. holes, P2 plug, 92" cable, 102" leads	CBH05491
3.248	5.25	3.000	1.000	750	230	(3) 3/4" dia. holes, EP box	CBH03741
3.248	5.25	3.000	1.000	750	230	(3) 3/4" dia. holes, EP box, 72" cable, 78" leads	CBH09274
3.250	5.250	3.000	1.000	1000	240	Bronze, (2) 3/8" and (1) 7/8" dia. hole, (1) 1 1/4" Lg. cutout EP box	CBH04153
3.250	5.25	5.625	1.000	1200	230	(2) 3/4" & (2) 7/8" dia holes, 1" slot, EP box, 72" cable, 84" leads	CBH09275
4.000	6.000	3.100	1.000	1200	240	EP Terminal box, (3) 3/4" dia. holes	CBH03979
5.000	6.500	2.250	0.750	700	240	Bronze, bolt clamp, (4) 3/4" dia. holes	CBH03753
5.000	6.500	5.875	0.750	2400	240	Bronze, (1) 2 1/2" dia. hole, (2) 7/8" dia. holes	CBH01382
5.000	7.000	6.500	1.000	3000	460	Brass, CT, EP box, 2.125 x 1.688 cutout	CBH09123
5.687	7.750	8.500	1.031	3000	230	Bronze, CT, EP box, 2.375 x 1.562 cutout	CBH09150
5.998	8.000	4.313	1.000	2400	230	Brass, EP box, (1) 3/4" dia. hole, 2.125 x 1.688 cutout	CBH09180
6.000	8.000	4.313	1.000	2400	240	C2 box, (2) 3/4" dia holes	CBH06161
6.000	8.000	4.313	1.000	2400	460	EP Terminal box, (1) 2 3/8" Lg. cutout, (2) 3/4" dia. holes	CBH04030
7.500	9.500	8.875	1.000	4000	460	Brass, CT, EP box, 2.750 x 1.875 cutout	CBH09124

⚠ WARNING: Cancer and Reproductive Harm - www.P65Warnings.ca.gov.

(800) 323-6859 • Email: sales@tempco.com

Cast-In Aluminum and Bronze Platen Die Heaters for Plastics Processing Equipment

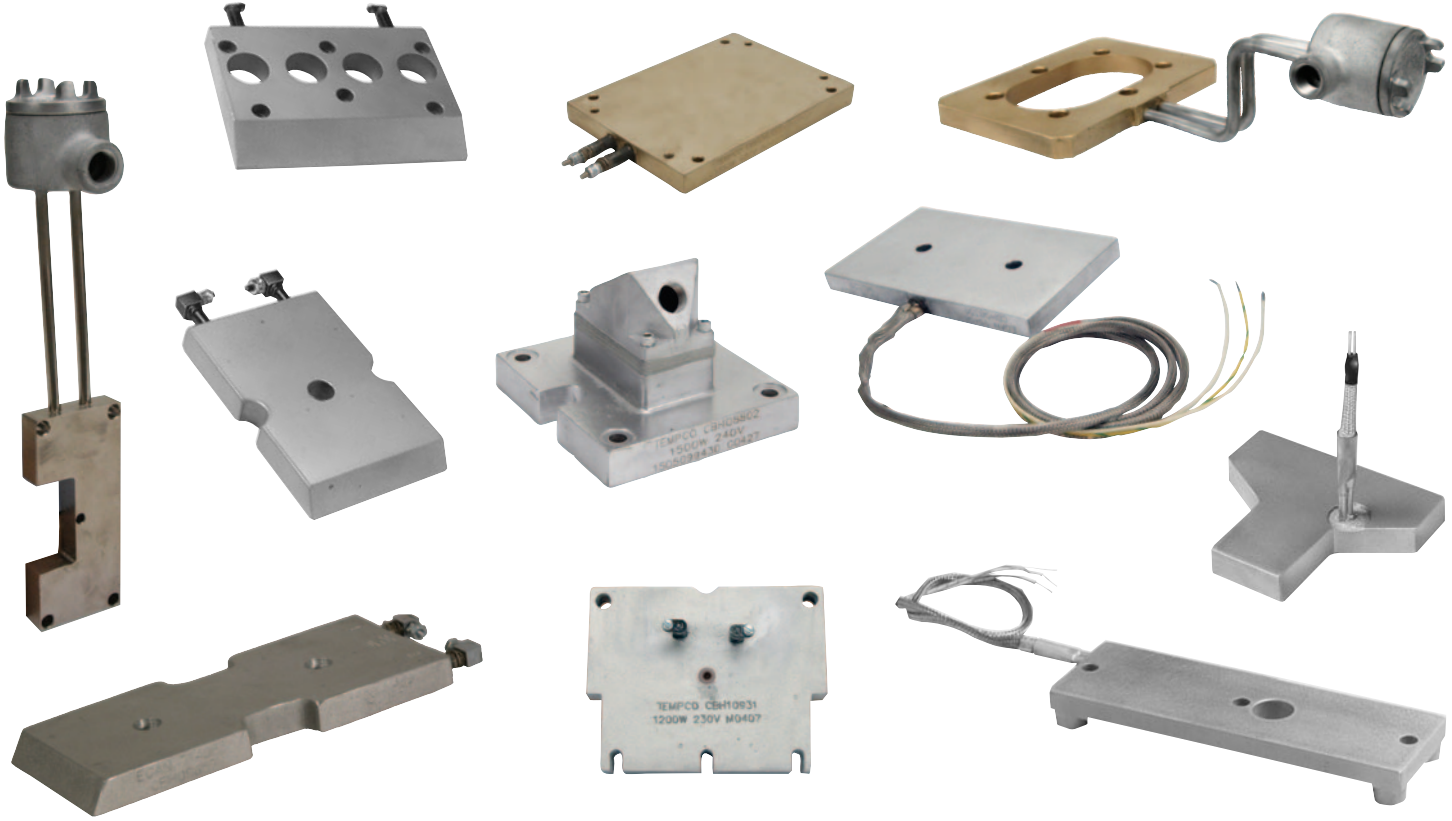

Tempco Cast-In Platen Heaters are widely accepted as the industry standard for heating critical, temperature-sensitive plastics processing downstream equipment.

Typically, plastic die applications are highly temperature sensitive and require extreme heater uniformity and reliability.

Tempco Cast-In Aluminum Platen Heaters are a logical choice to satisfy these critical application parameters, as the aluminum alloy has excellent thermal conductivity and a highly reliable, computer designed heating element which provides good contamination resistance. Optional cooling tubes can be cast-in to more precisely regulate the temperature of your process. The result is a highly efficient, uniform heater which, if used properly, can be expected to provide years of trouble-free service.

Cast-In Platen Heaters are generally manufactured in aluminum but can also be made in bronze or brass alloys to meet higher temperature processing requirements. For high volume requirements, the permanent mold process can be used to achieve the most effective economies of scale as well as yielding the best cosmetic appeal. To service customers with lower volume orders, Tempco's high quality no-bake sand mold process will be used, which assures excellent part quality and employs economical tooling.

Typical Applications for Tempco's Cast-In Platen Die Heaters:

- ↔ Sheet dies
- ↔ Plastic molds
- ↔ Plastic welding equipment
- ↔ Cast film dies
- ↔ Calendaring dies
- ↔ Screen changer equipment

Standard Cast-In Platen Heaters Design Features and Options

- * *Computer designed, precisely formed tubular heating element, optimizing the heat transfer pattern*
- * *A variety of termination options including terminal enclosure housings*
- * *Optional 1/4", 3/8", or 1/2" cooling tubes cast into the platen for liquid cool function*
- * *A variety of shapes and sizes made to your specifications*
- * *Through-holes, tapped holes or cutouts to facilitate mounting or obstructions*
- * *Precision machining of one or all surfaces of casting—specify your individual requirements.*



Note: Cast-In Platen Heaters are made to customer specifications. Please review our "Standard Sizes and Ratings" data along with our "How To Order" information to determine the heater best suited to your needs. Tempco also offers numerous sizes and styles off the shelf for immediate delivery.

For further information on large platen heaters see pages 3-18 through 3-23.

Stock and Standard (Non-Stock) Platen Die Heaters For Plastics Processing Equipment

The sizes and ratings listed are among the most commonly used. They will provide the shortest lead times.

Length in	Width in	Thickness in	Wattage	Volts	Notes	Part Number
4.000	3.000	0.750	400	230	(1) 5/8" dia. hole	CBH02755
4.500	3.500	0.750	600	230	(1) 5/8" dia. hole	CBH03065
3.875	3.500	0.750	500	230	(1) 5/8" dia. hole	CBH03468
3.875	3.500	0.750	500	230	(1) 5/8" dia. hole	CBH03147
4.000	4.000	0.750	600	240	60" Leads, 58" armor cable (1) 1/16" dia. hole	CBH05665
4.750	4.500	0.750	800	220	144" Leads, 120" braid, (1) 5/8" dia. hole	CBH04845
5.000	5.000	0.750	900	220	(4) 5/16" dia. holes, (1) 1/8" NPT, C2 box	CBH01045
5.500	3.500	0.750	600	240	66" Leads, 64" braid, (1) 1/16" dia. hole	CBH03869
5.500	4.500	0.750	900	230	48" Leads, 36" braid, (1) 1/16" dia. hole	CBH02698
5.875	3.875	0.750	750	230	(1) 5/8" dia. hole, 30° at front	CBH02255
5.875	3.875	0.750	750	230	(1) 5/8" dia. hole, 30° at front, has ground screw	CBH04170
6.000	3.500	0.750	800	230	(1) 5/8" dia. hole, (1) #10-32 tap	CBH05693
6.000	4.500	0.750	800	460	(2) 5/8" dia. holes	CBH04104
6.250	5.469	1.938	1000	230	(2) 5/16-16 tap, (2) 5/16-18 tap	CBH01090
7.000	4.000	0.625	800	240	P1 cup, (4) 5/16" dia. holes, (1) 1/2" dia. hole	CBH08409
7.500	3.000	1.000	1000	110	52" Leads & 48" Wire braid, (2) 1/16" dia. holes	CBH03453
7.500	5.500	1.000	1350	230	208" Leads, 180" braid, (1) 5/8" dia. hole	CBH04234
8.000	6.250	1.000	1200	230	(2) 1 1/2" dia. holes, (1) 1/8" NPT tap, (3) 1 1/2" slots	CBH01091
8.660	7.874	0.433	1250	220	24" Leads, 10" braid, (3) .213" dia. holes, (2) .234" dia. holes	CBH04086
9.500	6.250	1.000	1700	230	(3) 1 1/2" dia. holes, (3) 1 1/2" slots, (1) 1/8" NPT tap	CBH01088
11.500	3.375	0.750	1900	240	C2 box, (8) bolt holes, (1) 5/8" dia. hole	CBH07511
23.875	11.875	0.750	4300	240	(226) 1/4" dia. holes	CBH05195
13.250	11.625	1.000	3450	230	(7) 1 1/2" dia. holes, (3) 1 1/2" slots, (1) 1/8" NPT tap	CBH01089
21.653	7.480	0.866	4500	280	P1 cup, (6) bolt holes	CBH05054
22.000	10.750	0.625	5000	240	(2) elements	CBH06970
22.750	18.000	0.750	10000	480	30" Leads, 3-phase, (403) 1/4" dia. holes	CBH06162
22.750	18.000	0.750	10000	240	30" Leads, 3-phase, (403) 1/4" dia. holes	CBH06225
22.750	22.000	0.750	12200	480	31" Leads, 3-phase, (344) 1/4" dia. holes	CBH07475
23.875	11.875	0.750	4300	240	S: 8-32, Dual element, (226) 1/4" dia. holes	CBH06947
23.875	11.875	0.750	8000	240	S: 8-32, Dual element, (226) 1/4" dia. holes	CBH06948
26.000	22.750	0.750	13200	480	16" Leads, 3-phase, (305) 1/4" dia. holes	CBH07477
26.500	3.375	0.750	4000	240	(18) bolt holes, (1) 5/8" dia. hole, C2 box	CBH07594



Note: Part numbers are for aluminum heaters unless otherwise specified.



Note: Customer Assistance

If you have a special application requiring a custom manufactured Cast-In Aluminum or Bronze Platen Die Heater or need assistance selecting one of our standard die heaters, consult Tempco with your requirements. We offer complete engineering services and support, working with you every step of the way to ensure customer satisfaction.

CUSTOM Manufactured

For sizes and ratings not listed, **TEMPCO** will design and manufacture a Platen Heater to meet your requirements.

Specify the following:

- Length
- Width
- Thickness
- Wattage and Voltage
- Termination type (see pages 3-54 & 3-55)
- Alloy (Aluminum or Bronze)
- Special Features
- Machining Specifications
- Detailed Drawing

WARNING: Cancer and Reproductive Harm - www.P65Warnings.ca.gov.

Specialty Cast-In Aluminum and Bronze Heaters Used in Plastics Processing Equipment

Plastics Processing Equipment utilizes numerous types of specially designed Cast-In Aluminum and/or Bronze Heaters. In addition to the typical and commonly used cylindrical cast-in heaters, complex geometric shapes are used extensively as well.

The following two pages provide you with a small overview of our manufacturing capabilities by illustrating some popular cast-in heater shapes and how they are used. Special designs can be made to your specifications. Consult Tempco with your requirements.



Internal Ring Heater



Platen for Plastic Welding Equipment

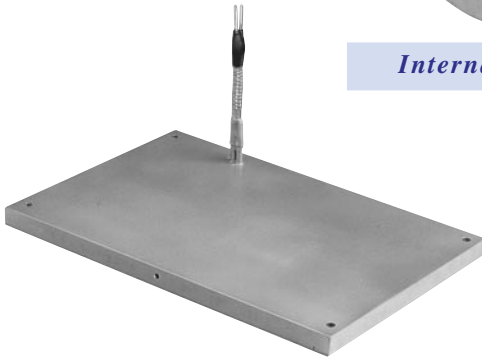

Flat Platen Heater



"U" Shaped Heater



Semicircular Shaped Heater

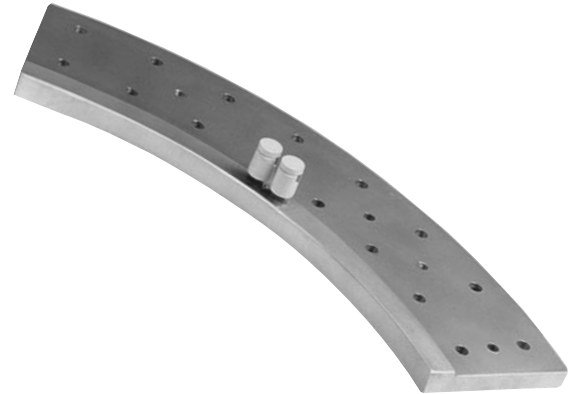

Segmented Ring Heater

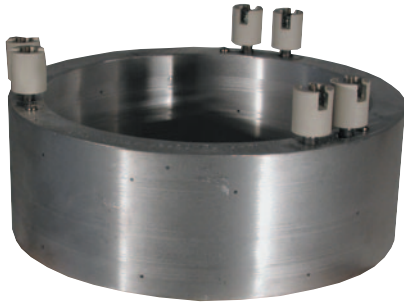

Internal Ring Heater

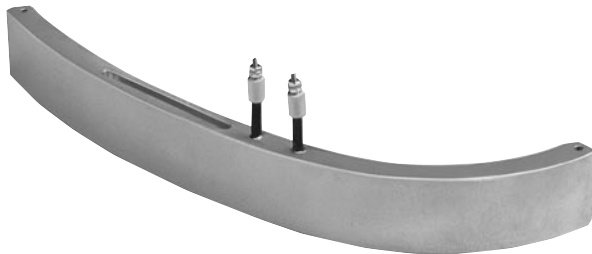

Laminating Radial Edge Heater



"L" Shape with Vent Clearance Hole

Specialty Cast-In Aluminum and Bronze Heaters Used in Plastics Processing Equipment



Cast Bronze Nozzle Heater Bushings For Runnerless Molding

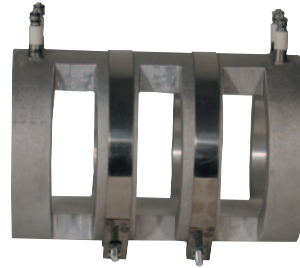

Vented Barrel Heater

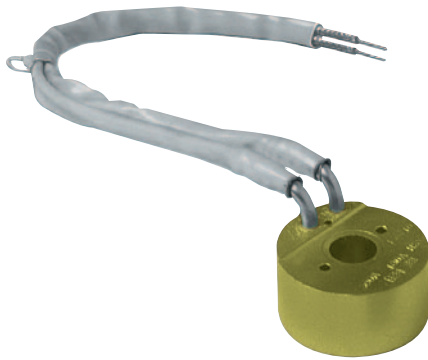

Ring Heaters

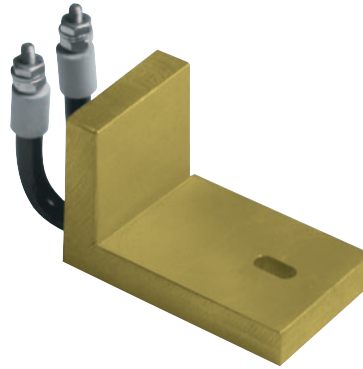

"L" Shaped Heater

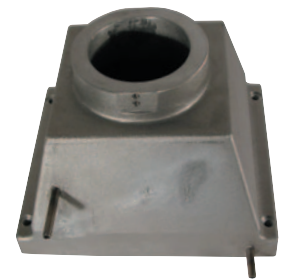

Hopper Feed Cooler



Large Holes for Vented Barrels



Feed Throat Cooler



Feed Throat Cooler

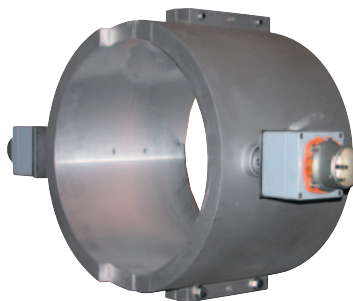

Rugged Electrical Terminal Housings With Meltric® Receptacles

Installation Recommendations

Installation Recommendations for Cast-In Thermal Components

Tempco Cast-In Heaters will provide long life and dependable, trouble-free service if properly installed, operated, and maintained as per the following recommendations:

Installation

1. Allow sufficient space for thermal expansion. The amount of space required depends upon the Cast-In Heater size, operating temperature and alloy.
2. Surface being heated must be free of any foreign materials and have a smooth finish.
3. Make sure that the casting is properly seated. The clamping devices used should be tightened down to the correct recommended torque. After initial heat-up, retighten fasteners to the correct recommended torque.

Recommended Torque:

10 ft-lb for 1/4–5/16 bolts, 20 ft-lb for 7/16–5/8 bolts

5. Thermal insulation can be used to reduce heat losses.
6. Avoid mounting heaters in an atmosphere containing combustible gases and vapors unless specifically manufactured for use in such conditions.
7. Liquid Cooled Cast-In Heater fittings must be securely tightened to prevent leaks.
8. To prevent overheating and heater failure, adequate temperature controls should be installed. For assistance in selecting temperature controls and thermocouples, see Tempco's (in-stock) complete line of Plug-In type Proportional Temperature Controls for heating and cooling applications in Section 13. Also see the listing on standard and hot melt thermocouples in Section 14.

Wiring

1. For connections at the heater terminals, use high temperature nickel conductor or nickel clad copper lead wire or alloy bus bar. Keep all electrical connections properly protected to eliminate electric shock to machine operators.
2. Heaters of equal wattage and voltage can be connected in series for higher voltage.
3. Heater installations must be properly grounded to eliminate electric shock hazard, and wiring must comply with electrical codes.
4. Always have a qualified electrician perform all wiring and connection of heaters and control components. Terminals must be tightened to the correct torque (2.5 ft/lb for terminal connections).

CAUTION: Castings are not designed to be lifted or carried by the terminations or leads.

Exposed electrical wiring on cast-in heater installations is a violation of Electrical Safety Codes including O.S.H.A.



Note: See page 16-11 for Wiring Diagrams and page 15-2 for lead wire selection

Operation

1. It is recommended to slow start the process during first use.
2. Do not operate above rated voltage. Excess voltage will result in heater failure.
3. Do not operate Cast-In Heaters above recommended temperatures. Heater temperature must be monitored and controlled. Use of over-temperature T/C is strongly recommended for higher temperature applications. Excess temperatures will result in heater failure and/or melting.
4. Electrical terminals must be kept free of contaminants, as spillage of plastic, water, oils, and their vapors can cause electric shorts, resulting in heater failure.
5. Liquid Cooled Cast-In Heaters must not be cycled to operate simultaneously. Thermal stresses may result in shorter heater life.
6. The water used on Liquid Cooled Cast-In Heaters must be properly treated. Hard water contains corrosive media that will contaminate the tubing, producing stress corrosion cracks and resulting in shorter heater life. Presence of minerals in water can cause clogged tubes that can result in poor heat transfer and eventually heater failure.

Maintenance

1. Never perform any type of service on heaters prior to disconnecting all electrical power.
2. To ensure good surface contact, periodically check clamping. Retighten clamping to the correct torque when required.
3. Repeat cycling of temperature controls can indicate poor surface contact or a burned-out heater.
4. Heater terminals must be kept free of plastics, oil, water, and any other foreign matter. As these materials carbonize, they create electrical shorts.
5. Heater terminal electrical connections must be kept tight. Loose connections can overheat and eventual destroy the connection or the heater terminal.
6. Water lines must be periodically checked for leaks. Water on heater terminals can be detrimental to the entire heating system.
7. Thermocouples must be kept free of contaminants and be checked for good response to temperature changes. Our recommendation is to change them periodically, as a bad thermocouple can be the cause of destroying an entire heating zone.

..... **Complete Your Installation With**
▼▼▼▼▼▼▼▼▼▼ **Accessories Available From Stock** ▼▼▼▼▼▼▼▼▼▼

Accessory	Catalog Section
* Stainless Steel Tubing and Fittings For Cooling Lines	3
* Pressure Transducers and Rupture Disks	12
* Temperature Controllers	13
* Temperature Sensors, Thermocouple Wire, Jacks & Plugs	14
* High Temperature Lead Wire & Fiberglass Tape, Ceramic Terminal Covers and Electric Plugs	15

View Product Inventory @ www.tempco.com

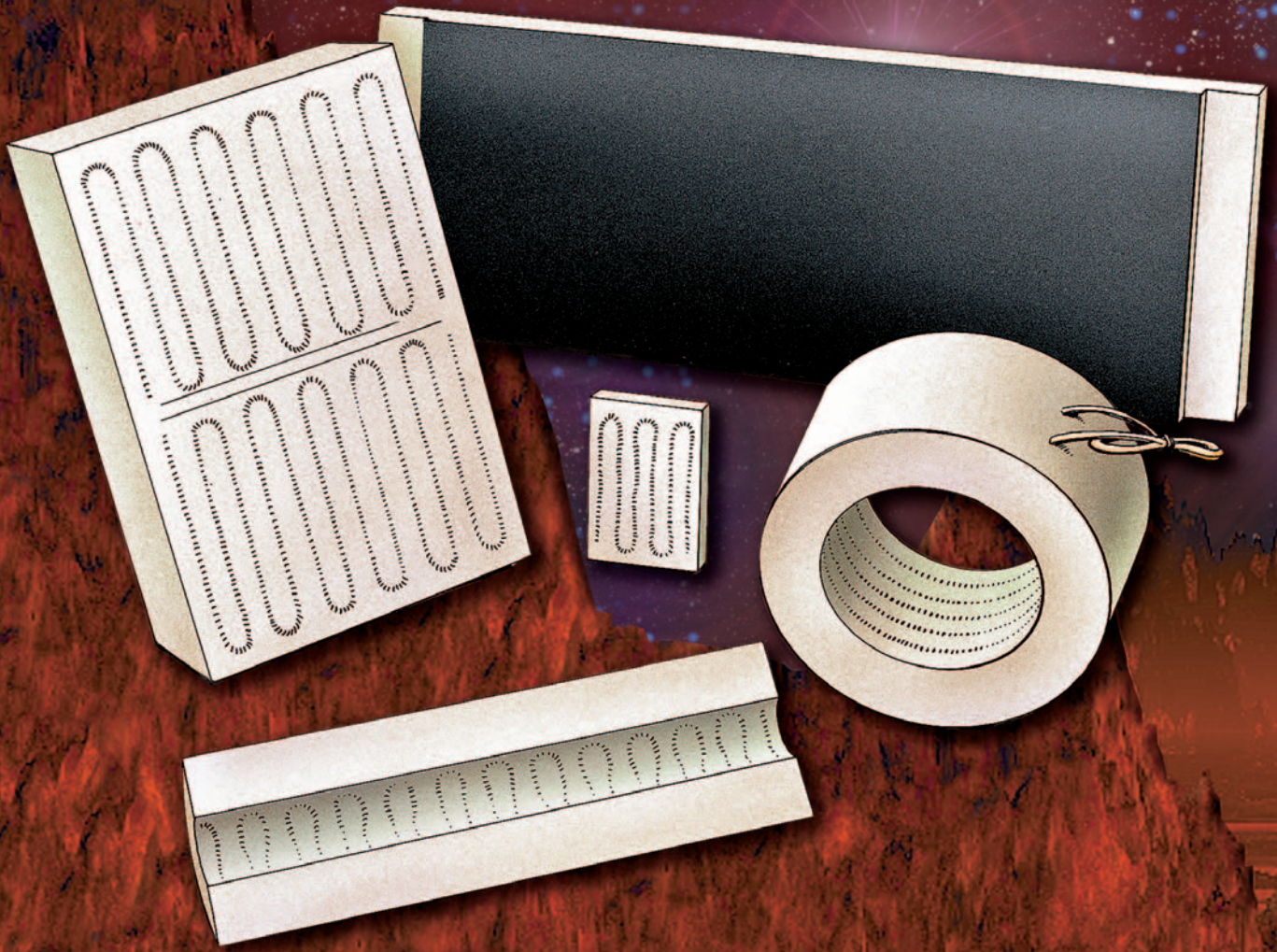

Table Of Contents

Pictorial Index	A-11	Applications & Dimensional Tolerances . . .	4-5
Introduction to High Temperature Ceramic Fiber Heaters	4-2	Flat Panel Heaters	4-6
Options & Accessories	4-3	Full Cylindrical Heaters	4-7
Properties & Performance	4-4	Semi-Cylindrical Heaters	4-8

4

section

Ceramic Fiber Heaters

Ceramic Fiber Heaters



Introduction

High Temperature Ceramic Fiber Heaters



Design Features

- * Standard Heaters to 1100°C (2012°F)
- * High Temperature Version to 1200°C (2192°F)
- * Low Thermally Conductive Built-In Insulation
- * Standard Flat Panel, Full Cylindrical and Semicylindrical Shapes
- * Fe-Cr-Al Alloy Resistance Wire Elements
- * Standard 9" long double-twisted bare wire leads
- * 100% Inorganic; free of Organics & Asbestos
- * Thermal Shock Immunity
- * Excellent Resistance to Chemical Attack

Industrial Uses

- | Industry | Application |
|-----------------|--|
| ↔ Aerospace | ***** Crystal Growth, R & D |
| ↔ Dental | ***** Manufacture of Crowns and Bridges |
| ↔ Metals | ***** Heat Treat and Temper |
| ↔ Plastics | ***** Sealers and Formers |
| ↔ Automotive | **** Metal Heat Treating and Paint Curing |
| ↔ Chemical | ***** Remove By-Products & Catalyst Materials |
| ↔ Crystals | ***** Preheat & Manufacturing of Optical and Gemstone Crystals |
| ↔ Glass | ***** Annealing Process & Preheat of Glass Manufacturing |
| ↔ Ceramic | ***** Extrusion Dies |
| ↔ Semiconductor | ** Diffusion Furnaces & Annealing Wafers |

Designed For High Temperatures and Efficiency

Tempco Ceramic Fiber Insulated Heaters combine a heat source with superior high temperature insulation—an ideal solution for an unlimited number of industrial heating applications. Tempco Ceramic Fiber Insulated Heaters produce fast, efficient, and reliable uniform heat to temperatures of 1100°C (2012°F). Higher temperature ratings, up to 1200°C (2192°F), are available with a limited number of designs.

Flat Panel, Full Cylindrical and Semi-Cylindrical Shaped Ceramic Fiber Insulated Heaters — Tempco Standard

These heaters are comprised of high-quality helically wound Fe-Cr-Al alloy resistance wire elements embedded in a rigid body of vacuum-formed high temperature refractory fiber. This ceramic fiber insulation has very low weight, thermal mass and thermal conductivity and thus can handle extremely rapid cycling.

The elements are typically mounted flush with the heated surface. The diameter of the helically wound element coil is kept to a minimum, reducing the difference between the element and chamber temperature, thus ensuring long heater life. This feature enables the design and manufacture of responsive heating systems and significantly reduces the risk of overheating the element.

- * Standard 9" long double-twisted bare wire leads.
- * Custom shapes are available on request.

All Tempco Ceramic Fiber Insulated Heaters are organic free and will not smoke or outgas.

MAXIMUM TEMPERATURE

The maximum temperature attainable is totally dependent on the application. To reach the maximum temperature stated, the application must be well insulated and sealed to trap the heat (like an oven) and allow the temperature to build. For example, to use a ceramic fiber cylindrical heater at its maximum temperature, the ends must be closed off with unheated insulated discs to minimize heat loss and allow the temperature to build.

Ceramic Fiber Heater Features and Options

Construction Characteristics

Tempco's standard Ceramic Fiber Heaters are designed for a maximum temperature of 1100°C (2012°F). The resistance wire is wound in a helical coil and embedded flush to the heater surface.

Tempco's High Temperature Ceramic Fiber Heaters are designed for a maximum temperature of 1200°C (2192°F). The resistance ribbon wire is helically wound and mounted at the heater surface using a method that exposes three sides of the coil.

The availability of High Temperature (1200°C) Ceramic Fiber Heaters is very limited. Consult Tempco with your requirements.

Unheated Molded Ceramic Fiber Panels and Cylinders

Tempco can manufacture unheated ceramic fiber panels, full and semi-cylinders for applications that require additional insulation. For example, flat circles can be made to cover the top or bottom of a cylindrical shaped heater to produce a small furnace. The unheated insulation components are made from a similar material as the heaters, so the specifications are the same.

To order, consult Tempco with your requirements.

Thermowells

Quartz glass thermowell tubes can be inserted perpendicular to the heater, usually all the way through, for use with temperature probes to sense the interior temperature. The sensor probes are ordered separately. For a typical thermocouple sensor probe, see page 14-14, MTA1.

For .125" diameter sensor probes, specify a 4mm ID thermowell tube.
For .187" diameter sensor probes, specify a 6mm ID thermowell tube.
For .250" diameter sensor probes, specify an 8mm ID thermowell tube.

Optional Vestibules on Full and Semi-Cylindrical Heaters

Vestibules are used to support full or semi-cylindrical heaters around a pipe to heat the material flowing through the pipe. The vestibule is made from 1" ceramic fiber board cut to the correct OD and ID and then cemented to one or both ends of standard size full or semi-cylindrical heaters. The overall length for standard vestibules would be the original heater plus 2" for a vestibule on both ends or 1" for a vestibule on one end. It is recommended that for maximum temperatures, a vestibule width of 1.5" to 2" be specified.

Full cylindrical heaters with (two) vestibules are available with Type 1, 4, or 5 leads.

Semi cylindrical heaters with (two) vestibules are available with Type 1 or 3 leads.

To order, consult Tempco with your requirements.

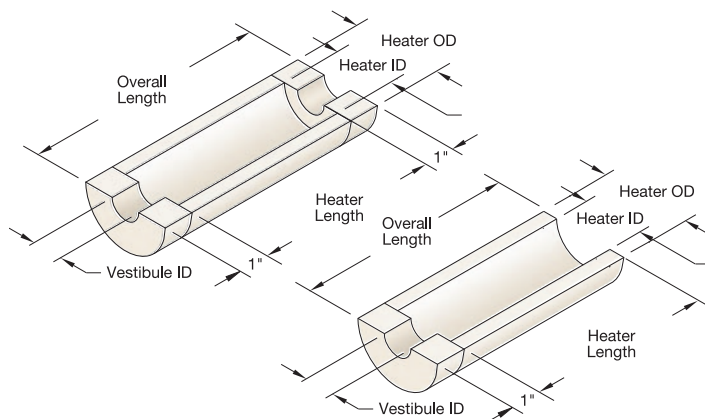

Mounting / Repair Accessories

Rigidizer

The external surface of ceramic fiber heaters is treated with a chemical rigidizer to give the heater the hardened shell typical of this type of heater. When the ceramic heater is cut in the field prior to installation for any purpose, or repairs are required, rigidizer should be used to recoat the surface.

Part Number: CFR00010 **Quantity:** 1 Gal.

Ceramic Fiber Cement

The cement has many general purposes, such as bonding ceramic fiber heaters together or adding additional external insulation.

Part Number: CFR00020 **Quantity:** 1 Gal.

Ceramic Putty

Made from high purity Asbestos-Free Aluminum Oxide-based ceramics with a melting point in excess of 3200°F (1760°C) and formulated with special ceramic binders that, on drying, produce a strong ceramic body.

- ✓ **Resistant** to molten metals, most chemicals, oxidizing and reducing atmospheres.
- ✓ **Use for installation** repairs to brick, mortar, burner blocks, insulation, furnace holders, thermocouples, etc.
- ✓ **Applications include** bonding and bonding ceramic fiber components, high temp. insulation, insulation of pipes, supports, burners, turbines, etc.

Size: 4 oz. Squeeze Tube **Part Number:** CFR00030

Size: 11 oz. Caulking Tube **Part Number:** CFR00032

SPECIFICATIONS

Melting Point	3200°F (1760°C)
Continuous Service	2300°F (1260°C)
Base Material	Al ₂ O ₃
Density	40-50 lbs./cu. ft.
Specific Heat	0.25 BTU/# °F
Dielectric Constant at 10 ⁸ cps	1.61
Loss Factor	0.017
Dielectric Strength	100 Volts/mm
Thermal Conductivity at 500°F (260°C) ...	0.65



Properties & Performance

Characteristics and Properties

Composition of Insulation

Al ₂ O ₃ (Alumina).....	38%
SiO ₂ (Silica).....	62%
Organics	0%

Bond.....Silica

Bulk Density

gm/cm³, (lb/cu. ft.) 0.28 (18)

Thermal Conductivity

W/m ² K (Btu/hr ² F ft. ² /in.)	
400°C (752°F).....	0.10 (0.8)
1100°C (2012°F)	0.22 (1.5)

Flexural Strength MPa (Psi)

As received	0.17 (25)
After 24 hrs. at 1000°C.....	0.354 (51.34)

Compressive Strength MPa (Psi)

10% Deflection 0.054 (7.83)

Stability—Linear Shrinkage

24 hrs. at temperature	
800°C (1472°F).....	0.3%
1000°C (1832°F)	1.8%
1200°C (2192°F)	2.5%

Performance Characteristics

Performance of a Typical Round Ceramic Fiber Heater

The performance data represented in the chart was obtained by combining a Fiber Insulated Heater with 3" discs of insulation top and bottom. This assembly, which can be representative of many industrial and laboratory heating applications, was cycled with no load. Cool down rates were determined by turning the power off. Assembly was left intact. The “outside wall” temperature was measured on the external surface of the sidewall.

**Time vs. Temperature of a Typical Full Round High Temperature Ceramic Fiber Heater
5.5" I.D. x 12" H x 11" O.D.**

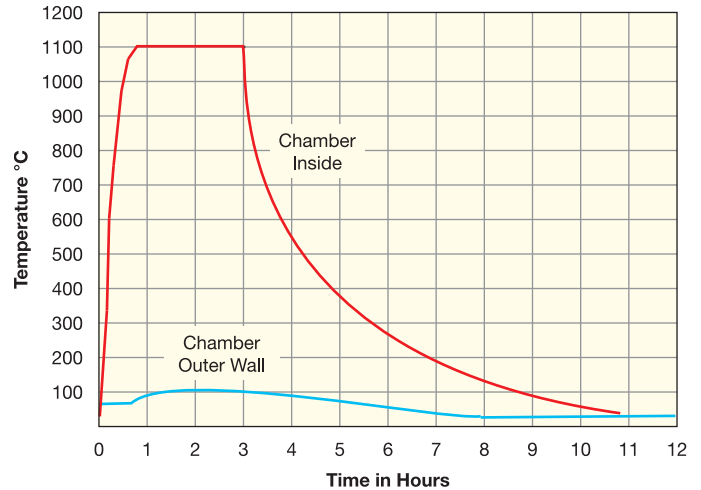

Performance of a Typical Rectangular Furnace

Test chamber left and right walls fabricated from Standard Fiber Insulated Heaters (24" x 36" x 5") and insulation boards. This size chamber, approximately 10 cubic feet, was chosen to best reflect performance characteristics of flat panel heaters as

used in a broad section of industrial applications. Chamber walls, roof and floor are 5" thick insulation. Cool down rate was plotted with data generated after element power was turned off. Chamber door remained closed. Chamber contained no load.

Time vs. Temperature of an (approx.) 10 cubic foot furnace chamber incorporating Tempco's Ceramic Fiber Heaters.

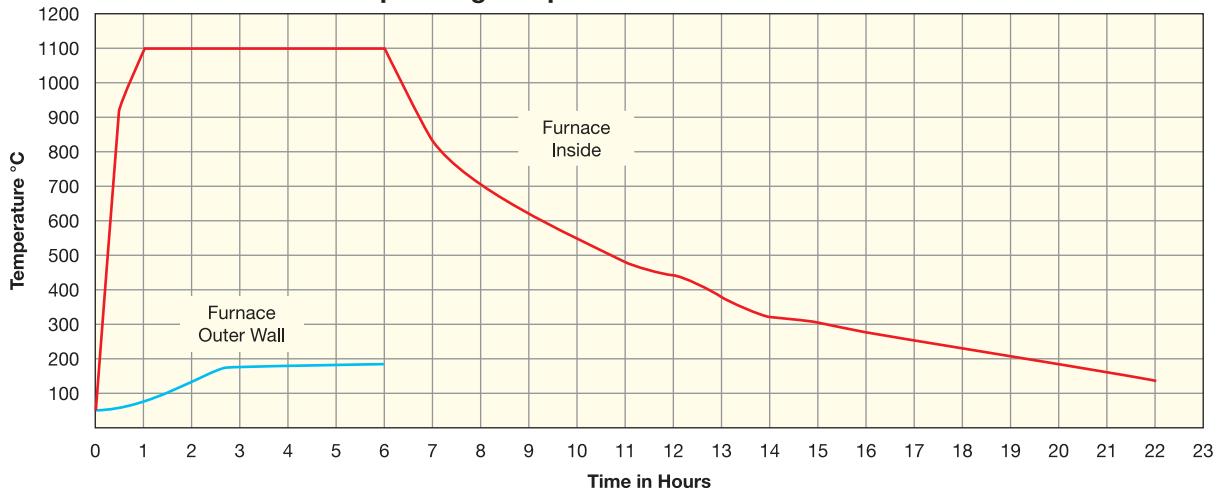

Application Guidelines

- High Temperature Ceramic Fiber heaters are *designed for radiant heat transfer* only. They are not intended for contact heating. They do not have the physical strength found in band, cartridge, strip or cast-in heaters.
- Mounting methods** such as washers, pins, screws, overlapping edge clamps, and interlocking edges work well with Ceramic Fiber heaters. Cementing is not recommended because it will not allow expansion or contraction.
- The **maximum temperature attainable is totally dependent on the application**. To reach the maximum temperature stated, the application must be well sealed (like an oven) to trap the heat generated by the heater core and allow the temperature to build. If the heaters are used in an open environment the maximum temperatures will not be reached. For example, to use a ceramic fiber cylindrical heater at its maximum temperature, the ends must be closed off with un-heated insulated discs to minimize heat loss and allow the temperature to build.
- Ceramic Fiber Heaters have a **very high porosity factor** and cannot be sealed against contamination and possible damage to the heating element. Keep the furnace free of contaminants that can vaporize at high temperatures.
- The **temperature for most applications** needs to be controlled at a specific temperature. This can be most readily accomplished thru the use of fast responding electronic PID temperature controls. See Section 13 for single loop controls and Complete Control Systems.
- Thermocouple temperature probes** are used to sense the temperature of the application and provide feedback to the Temperature Control System. Typically, Type K thermocouples with an operating range up to 1260°C/2300°F are commonly used. Alloy 600 sheath material, good up to 1177°C/2150°F should be specified. Mineral insulated probes such as Tempco's MTA1 on catalog page 14-14 are highly recommended.
- Be careful with any electrical connections** made in the heated portion of the application. The connections must be rated for the expected operating temperature and current flow.
- Use only inorganic fibers and binders** to avoid corrosive fumes that could damage the heater.
- Ceramic Fiber Heaters are easily damaged from **careless mechanical handling**, so handle the units and leads carefully.

Dimensional Tolerances

Flat Panels

Width:	4", 6", 8"	± 1/8"
	10" through 32"	± 1/4"
Length:	6"	± 1/8"
	12" through 44"	± 1/4"
Thickness:	1"	± 1/8"
	2" through 4"	± 1/4"

Full Cylindrical

I.D.:	1.5" through 4"	± 1/8"
	5" through 18"	± 1/4"
O.D.:	3.5"	± 1/8"
	5" through 24"	± 1/4"
Length:	6"	± 1/8"
	12" and 18"	± 1/4"

Semi-Cylindrical

I.D.:	2" and 3.5"	± 1/8"
	5" through 18"	± 1/4"
O.D.:	6" through 22"	± 1/4"
	Length: 6"	± 1/8"
	12" through 36"	± 1/4"



**Standard Temperature (1100°C)
Semi-Cylindrical Heater**

2" I.D. × 6" O.D. × 18" Long
1130W, 240V



**High Temperature (1200°C)
Flat Panel Heater**

12" Square × 2" Thick
1100W, 120V



**High Temperature (1200°C)
Semi-Cylindrical Heater**

7" I.D. × 11" O.D. × 12" Long
1600W, 240V



Note: Temperature ratings of 1200°C (2192°F) are available on a limited number of designs. Consult Tempco.

Ceramic Fiber Heaters



Flat Panels

Ceramic Fiber Flat Panel Heaters

Panel Styles

Type 1 Leads Shown

Style 1— Entire Panel Heated

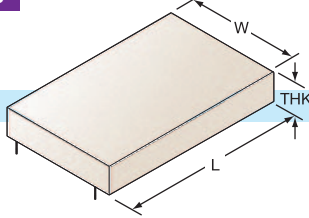

Style 2— Unheated Ends in Width

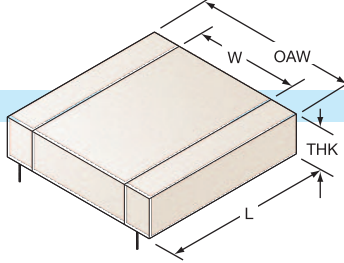

Style 3— Unheated Ends in Length

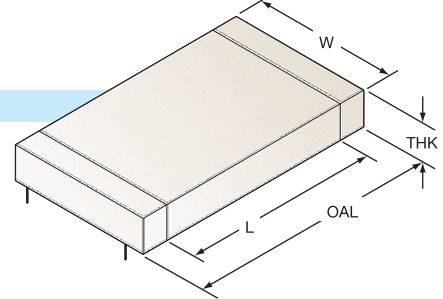

Lead Locations

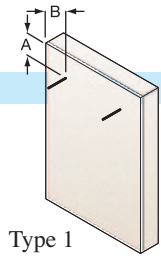

Type 1

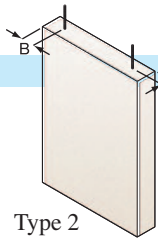

Type 2

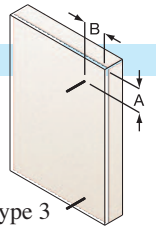

Type 3

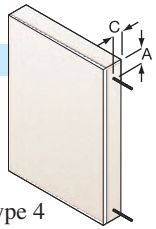

Type 4

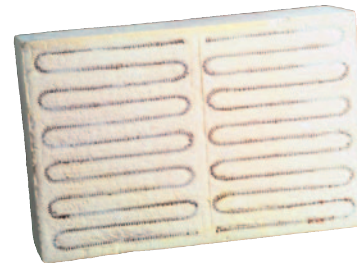

Standard Panel Heater

18" W ×
24" L ×
3" Thick

Ordering Information

Standard Units

Select a **Flat Panel Heater** by size, electrical rating and style from the table below. To complete the part number, add the required lead location number.

For example

CFR1001□ has Type 2 Leads.

Standard leads are double twist 9" long high-temperature bare wire.

Custom Designed/Manufactured Flat Panel Heaters

Custom manufactured Flat Panel Ceramic Fiber Heaters are available; consult **Tempco** with your requirements. **Standard lead time is 4 weeks.**

Please Specify the following:

- 1100°C or 1200°C Construction Style
- Length
- Width
- Voltage and Wattage
- Lead Location and Type
- Special Features



Note: See page 4-2 for maximum temperature guidelines

⚠ WARNING: Cancer and Reproductive Harm - www.P65Warnings.ca.gov.

Standard (Non-Stock) Flat Panel High Temperature Ceramic Fiber Heaters (1100°C Construction Style)

All Dimensions are in inches. Lead Locations A, B and C are approximate. Complete the part number by adding the required lead location number.

Heated		Watts	Volts	Style 1			Style 2			Style 3								
W	L			Thk	Part Number	Lead Location			Part Number	OAW	Lead Location			Part Number	OAL	Lead Location		
				A	B	C					A	B	C					
4	6	1	250	60	CFR1001	1.0	1.0	0.5	CFR1019	6	1.0	2.0	0.5	CFR1037	8	2.0	1.0	0.5
4	12	1	500	60	CFR1002	1.0	1.0	0.5	CFR1020	6	1.0	2.0	0.5	CFR1038	14	2.0	1.0	0.5
6	6	2	375	60	CFR1003	1.5	1.5	1.0	CFR1021	10	1.5	3.5	1.0	CFR1039	10	3.5	1.5	1.0
6	12	2	750	120	CFR1004	1.5	1.5	1.0	CFR1022	10	1.5	3.5	1.0	CFR1040	16	3.5	1.5	1.0
6	18	2	1125	120	CFR1005	1.5	1.5	1.0	CFR1023	10	1.5	3.5	1.0	CFR1041	22	3.5	1.5	1.0
6	24	2	1500	120	CFR1006	1.5	1.5	1.0	CFR1024	10	1.5	3.5	1.0	CFR1042	28	3.5	1.5	1.0
8	12	2	1000	120	CFR1007	2.0	2.0	1.0	CFR1025	12	2.0	4.0	1.0	CFR1043	16	4.0	2.0	1.0
8	18	2	1500	120	CFR1008	2.0	2.0	1.0	CFR1026	12	2.0	4.0	1.0	CFR1044	22	4.0	2.0	1.0
8	24	2	2000	120	CFR1009	2.0	2.0	1.0	CFR1027	12	2.0	4.0	1.0	CFR1045	28	4.0	2.0	1.0
12	12	2	1500	120	CFR1010	2.0	2.0	1.0	CFR1028	16	2.0	4.0	1.0	CFR1046	16	4.0	2.0	1.0
12	18	2	2250	120	CFR1011	2.0	2.0	1.0	CFR1029	16	2.0	4.0	1.0	CFR1047	22	4.0	2.0	1.0
12	24	2	3000	240	CFR1012	2.0	2.0	1.0	CFR1030	16	2.0	4.0	1.0	CFR1048	28	4.0	2.0	1.0
12	36	2	4500	240	CFR1013	2.0	2.0	1.0	CFR1031	16	2.0	4.0	1.0	CFR1049	40	4.0	2.0	1.0
18	18	3	3375	240	CFR1014	2.5	2.5	1.5	CFR1032	24	2.5	5.5	1.5	CFR1050	24	5.5	2.5	1.5
18	24	3	4500	240	CFR1015	2.5	2.5	1.5	CFR1033	24	2.5	5.5	1.5	CFR1051	30	5.5	2.5	1.5
18	36	3	6750	480	CFR1016	2.5	2.5	1.5	CFR1034	24	2.5	5.5	1.5					
24	24	4	6000	480	CFR1017	3.0	3.0	2.0	CFR1035	32	3.0	7.0	2.0	CFR1053	32	7.0	3.0	2.0
24	36	4	9000	480	CFR1018	3.0	3.0	2.0	CFR1036	32	3.0	7.0	2.0					

Ceramic Fiber Cylindrical Heaters

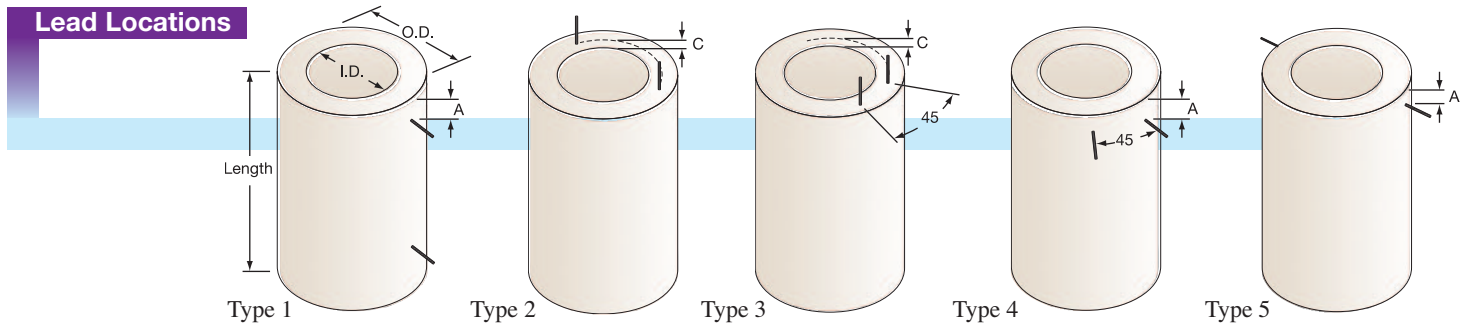

Standard (Non-Stock) Full Cylindrical Shaped High-Temperature Ceramic Fiber Heaters (1100°C Construction Style)

All Dimensions are in inches. Lead Locations A and C are approximate. Complete the part number by adding the required lead location number.



Note: See page 4-2 for maximum temperature guidelines

I.D.	O.D.	Length	Watts	Volts	Lead Location		Part Number
					A	C	
1.5	3.5	12.0	600	120	1.5	0.5	CFR3004 <input type="checkbox"/>
2.0	5.0	6.0	400	60	1.0	0.8	CFR3005 <input type="checkbox"/>
2.0	5.0	12.0	800	120	1.5	0.8	CFR3006 <input type="checkbox"/>
3.0	6.0	6.0	600	120	1.0	0.8	CFR3007 <input type="checkbox"/>
3.0	6.0	12.0	1200	120	1.5	0.8	CFR3008 <input type="checkbox"/>
4.0	8.0	6.0	800	120	1.0	1.0	CFR3009 <input type="checkbox"/>
4.0	8.0	12.0	1600	120	1.5	1.0	CFR3010 <input type="checkbox"/>
5.0	9.0	6.0	1000	120	1.0	1.0	CFR3011 <input type="checkbox"/>
5.0	9.0	12.0	2000	120	1.5	1.0	CFR3012 <input type="checkbox"/>
6.0	10.0	6.0	1200	120	1.0	1.0	CFR3013 <input type="checkbox"/>
6.0	10.0	12.0	2400	120	1.5	1.0	CFR3014 <input type="checkbox"/>
6.0	10.0	18.0	3500	240	2.0	1.0	CFR3015 <input type="checkbox"/>
8.0	12.0	6.0	1600	120	1.0	1.0	CFR3016 <input type="checkbox"/>
8.0	12.0	12.0	3100	240	1.5	1.0	CFR3017 <input type="checkbox"/>
10.0	16.0	6.0	2000	120	1.0	1.5	CFR3019 <input type="checkbox"/>
10.0	16.0	12.0	3900	240	1.5	1.5	CFR3020 <input type="checkbox"/>
10.0	16.0	18.0	5900	240	2.0	1.5	CFR3021 <input type="checkbox"/>
12.0	18.0	12.0	4700	240	1.5	1.5	CFR3023 <input type="checkbox"/>
12.0	18.0	18.0	7100	240	2.0	1.5	CFR3024 <input type="checkbox"/>
14.0	20.0	18.0	8200	240	2.0	1.5	CFR3026 <input type="checkbox"/>
18.0	24.0	12.0	7100	240	1.5	2.0	CFR3028 <input type="checkbox"/>



Standard Full Cylindrical Shaped Heater
8" I.D. × 12" O.D. × 6" Long

Ordering Information

Standard Units

Select a **Full Cylindrical Shaped Heater** by size and electrical rating from the table above. To complete the part number add the required lead location number.

For example

CFR3004 has Type 2 Leads.

Standard leads are double twist 9" long high-temperature bare wire.

Custom Designed/Manufactured Full Cylindrical Shaped Heaters

Custom manufactured Full Cylindrical Shaped Ceramic Fiber Heaters are available; consult **Tempco** with your requirements. **Standard lead time is 4 weeks.**

Please Specify the following:

- 1100°C or 1200°C Construction Style
- Length
- Inner Diameter
- Outer Diameter
- Wattage
- Voltage
- Lead Location and Type

WARNING: Cancer and Reproductive Harm - www.P65Warnings.ca.gov.

Ceramic Fiber Heaters



Semi-Cylindrical Shapes

Ceramic Fiber Semi-Cylindrical Heaters

Standard (Non-Stock) Semi-Cylindrical Shaped High-Temperature Ceramic Fiber Heaters (1100°C Construction Style)

 **Note:** See page 4-2 for maximum temperature guidelines

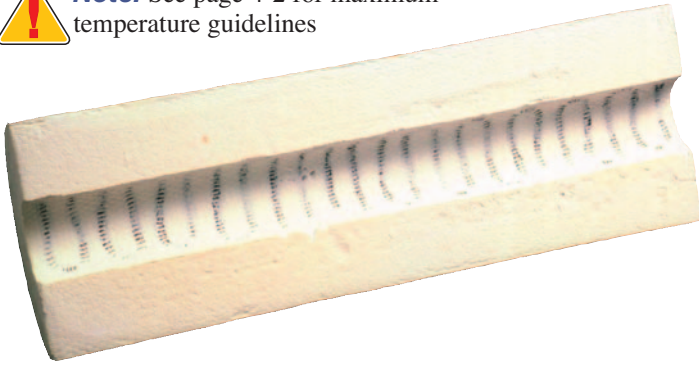

Standard Semi-Cylindrical Shaped Heater
2" I.D. × 6" O.D. × 18" Long

All Dimensions are in inches. Lead Locations A, B and C are approximate. Complete the part number by adding the required lead location number.

I.D.	O.D.	L	Watts	Volts	Lead Location			Part Number
					A	B	C	
2.0	6.0	6.0	200	60	1.0	1.0	1.0	CFR5003 <input type="checkbox"/>
2.0	6.0	12.0	400	120	1.5	1.0	1.0	CFR5004 <input type="checkbox"/>
2.0	6.0	18.0	600	120	2.0	1.0	1.0	CFR5005 <input type="checkbox"/>
2.0	6.0	24.0	800	240	2.0	1.0	1.0	CFR5006 <input type="checkbox"/>
3.5	7.5	6.0	350	60	1.0	1.5	1.0	CFR5007 <input type="checkbox"/>
3.5	7.5	12.0	700	120	1.5	1.5	1.0	CFR5008 <input type="checkbox"/>
5.0	9.0	6.0	500	60	1.0	1.5	1.0	CFR5011 <input type="checkbox"/>
5.0	9.0	12.0	1000	120	1.5	1.5	1.0	CFR5012 <input type="checkbox"/>
5.0	9.0	18.0	1500	240	2.0	1.5	1.0	CFR5013 <input type="checkbox"/>
5.0	9.0	24.0	2000	240	2.0	1.5	1.0	CFR5014 <input type="checkbox"/>
5.0	9.0	30.0	2500	240	2.5	1.5	1.0	CFR5015 <input type="checkbox"/>
5.0	9.0	36.0	3000	240	2.5	1.5	1.0	CFR5016 <input type="checkbox"/>
6.5	10.5	6.0	650	120	1.0	2.0	1.0	CFR5017 <input type="checkbox"/>
6.5	10.5	12.0	1300	240	1.5	2.0	1.0	CFR5018 <input type="checkbox"/>
6.5	10.5	18.0	1950	240	2.0	2.0	1.0	CFR5019 <input type="checkbox"/>
6.5	10.5	24.0	2600	240	2.0	2.0	1.0	CFR5020 <input type="checkbox"/>
8.0	12.0	12.0	1600	240	1.5	2.0	1.0	CFR5023 <input type="checkbox"/>
8.0	12.0	18.0	2400	240	2.0	2.0	1.0	CFR5024 <input type="checkbox"/>
8.0	12.0	24.0	3200	240	2.0	2.0	1.0	CFR5025 <input type="checkbox"/>
8.0	12.0	36.0	4800	240	2.5	2.0	1.0	CFR5027 <input type="checkbox"/>
10.0	14.0	12.0	2000	240	1.5	2.0	1.0	CFR5028 <input type="checkbox"/>
10.0	14.0	18.0	3000	240	2.0	2.0	1.0	CFR5029 <input type="checkbox"/>
10.0	14.0	24.0	4000	240	2.0	2.0	1.0	CFR5030 <input type="checkbox"/>
12.0	16.0	12.0	2400	240	1.5	2.0	1.0	CFR5033 <input type="checkbox"/>
12.0	16.0	18.0	3600	240	2.0	2.0	1.0	CFR5034 <input type="checkbox"/>
12.0	16.0	24.0	4800	240	2.0	2.0	1.0	CFR5035 <input type="checkbox"/>
15.0	19.0	12.0	3000	240	1.5	2.0	1.0	CFR5038 <input type="checkbox"/>
15.0	19.0	18.0	4500	240	2.0	2.0	1.0	CFR5039 <input type="checkbox"/>
15.0	19.0	24.0	6000	240	2.0	2.0	1.0	CFR5040 <input type="checkbox"/>
15.0	19.0	30.0	7500	240	2.5	2.0	1.0	CFR5041 <input type="checkbox"/>
15.0	19.0	36.0	9000	240	2.5	2.0	1.0	CFR5042 <input type="checkbox"/>

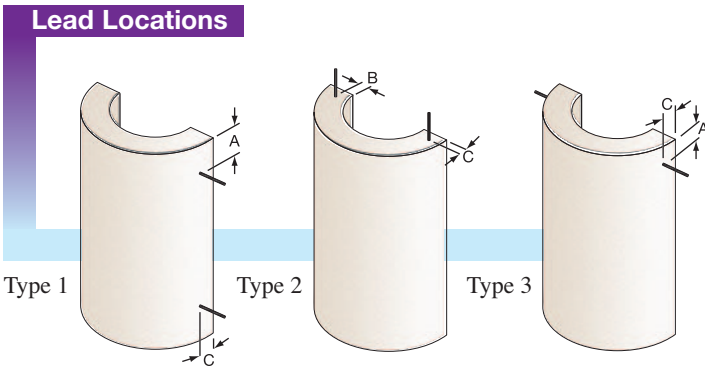

 **Note:** Semi-Cylindrical Heaters are produced individually, but made to fit together in a full circle without a gap.

Ordering Information

Standard Units

Select a **Semi-Cylindrical Shaped Heater** by size and electrical rating from the table above. To complete the part number add the required lead location type by number.

For example

CFR5003 has Type 2 Leads.
Standard leads are double twist 9" long high-temperature bare wire.

Custom Designed/Manufactured Semi-Cylindrical Shaped Heaters

Custom manufactured Semi-Cylindrical Shaped Ceramic Fiber Heaters are available; consult **Tempco** with your requirements.

Standard lead time is 4 weeks.

Please Specify the following:

- 1100°C or 1200°C Construction Style
- Length
- Inner Diameter
- Outer Diameter
- Wattage
- Voltage
- Lead Location and Type

 **WARNING:** Cancer and Reproductive Harm - www.P65Warnings.ca.gov.



Table Of Contents

Pictorial Index	A-12	Oxygen Analyzer Heaters.....	5-15
Mightyband™ Heaters	5-2	Tempco-Pak Heaters.....	5-16
Tempco Replacement Heaters for OEM		Bulk Round Heater Cable	5-24
Hot Runner Bushings	5-9	Mini-Coil Band Heaters	
Mightyband™ Heaters		For Hot Runner Systems	5-26
(Square & Rectangular Cable)	5-10	Cast Nozzle Heater Bushings	5-28
Tempco Replacement Heaters for OEM		Gamma Series Dual Sleeve	
Hot Runner Systems	5-11	Mini-Coil Heater	5-30

Cartridge Heaters for Runnerless Molding can be found in Section 2

Tubular Heaters for Runnerless Molding can be found in Section 10

5

section

Coil & Cable Heaters

Mightyband™ Coil Heaters



Design Features

- * Temperatures up to 1800°F (982°C)
- * Precise temperature control
- * Choice of lead orientation
- * Built-in type J or K Thermocouple
- * Round, square and rectangular cable
- * Rugged, durable construction
- * Unheated straight section
- * Fast response time
- * Choice of lead protection
- * Longer heater life
- * Higher watt densities
- * Made to customer specifications

Applications

Tempco offers from stock a large selection of standard Mightyband coil heaters for plastic injection runnerless molding bushings and for internally heated injection machine nozzles. The inside diameter of a coiled heater is wound undersized for a screw-on fit. Therefore, hold-down straps are not usually required.

Construction Characteristics

Tempco's dedication to quality and product improvement has led us to the development of a second generation of Mightyband heaters.

Manufactured for trouble-free performance in operations involving heating of cylindrical-shaped surfaces where precise temperature control is essential. Especially adapted as an alternate heat source for demanding and high temperature applications where other types of heaters have failed.

The design and manufacturing concept incorporates a built-in thermocouple, with a grounded junction terminating at the end of the cable opposite to the lead end. In some heaters, the thermocouple junction can be terminated anywhere within the coil section. Consult Tempco for the availability of this option on your specific heater.

The built-in thermocouple and the overall low mass construction provide quick response for positive temperature control. Incorporating the thermocouple into the heater construction eliminates the need for separate thermocouples, which have proven to be expensive, fragile and impractical.

Tempco Mightyband heaters have opened new frontiers and revolutionized the plastic injection runnerless molding industry since their introduction by Tempco in 1977. They provided the manufacturers of this type of equipment with a new and more effective heating element concept, thus allowing them to design and manufacture new, improved, and more efficient runnerless molding systems, with the capabilities required

to meet the ever-increasing demand for processing engineering resins and high production output requirements of today's industrial and consumer markets.

One specific way to improve the Mightyband heater design is to use a square or rectangular mineral insulated cable, which has a flat surface contact, allowing better heat conduction and a faster start-up time.

A
.....
REVOLUTIONARY
.....
CONCEPT
.....
IN
.....
HEATER
.....
DESIGN
.....

Standard Type J thermocouple with 304 stainless steel heater sheath is recommended for temperatures up to 1500°F (815°C). An optional Type K thermocouple with Inconel® 600 heater sheath for temperatures up to 1800°F (982°C) is available upon request. In some applications, the built-in thermocouple may not be required. In this case, it can be omitted from the heater cable.

The heating source for the Mightyband heater is a resistance wire in straight form or wound into a miniature helical coil. Selecting the best-suited resistance wire configuration is predetermined by an engineering formula applied to the specific heater design.

On Mightyband heaters where wire wound resistance coils are used, the tail end of the heater cable is usually unheated. Optional unheated or cooler tail sections are available on straight resistance wire heater designs. Consult Tempco with your specific requirements.

The swaging and drawing process involved in manufacturing the heater cable for Mightyband heaters compacts the ceramic insulators that house the heating element and thermocouple wire into a solid mass, producing a rugged and durable heater cable, providing excellent thermal conductivity, dielectric strength and quick thermocouple response.

Mightyband™ Coil Heater Specifications

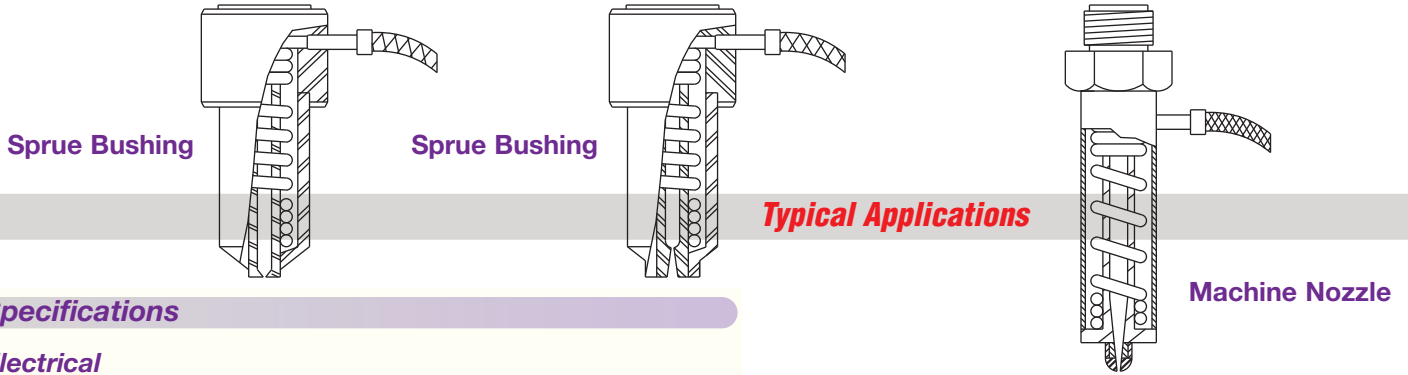

Specifications

Electrical

- Resistance Tolerance: ±10%
 - Wattage Tolerance: ±10%
 - Maximum Amperage: 20 Amps
 - Standard Voltage: 120 or 240 Volts
- Higher or lower voltages applicable for specific heater designs; consult Tempco with your requirements.*

Dimensional

- Standard square cable: 0.125", 0.134" square
- Standard rectangular cable: 0.110" × 0.160"
- Standard round cable diameters: 0.115", 0.120", 0.125"
0.132", 0.153", 0.163"
Others available upon request.
- Cable diameter tolerance: ±0.005
- Standard potting adapter: 5/16" Diameter
Used with heater only and heater with T/C leads, 20 gauge and under.
- 1/2" Diameter
Used with heater only and heater with T/C leads, 18 gauge to 10 gauge.
- Standard potting adapter length: 1-1/2"
Other lengths available.
- Standard coil I.D.: From 3/8" up to 2-1/2" in any increments.
Applicable Coil I.D. is subject to cable diameter.
- Coil I.D. Tolerance: 3/8" to 3/4", +0.000", -0.020"
..... 7/8" to 1-1/4", +0.000", -0.030"
..... 1-1/2" to 2-1/2", +0.000", -0.060"
- Coil Width (length): Up to 12" on 3/8" to 3/4" I.D.
..... Up to 16" on 7/8" to 1-1/4" I.D.
..... Up to 18" on 1-1/2" to 2-1/2"
- Coil Width Tolerance: 0 to 6": +0, -1/8"
..... 6 to 12": +1/8", -1/4"
..... 12 to 18": ±1/4"
- Standard Sheath Material: 304 stainless steel
For temperatures up to 1500°F (815°C)
- Optional Sheath Material: Inconel® 600
For temperatures up to 1800°F (982°C)
- Standard Thermocouple: ANSI Type J
- Optional Thermocouple: ANSI Type K
- Minimum Bending Radius: Two times the sheath diameter

Typical Configurations

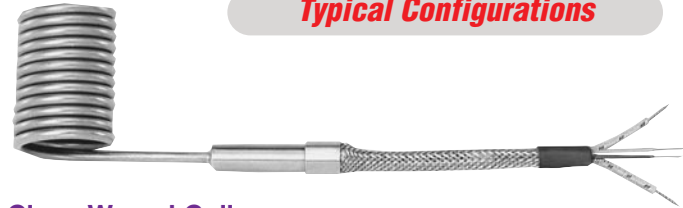

Close Wound Coil



Distributed Wattage

By specifically arranging a coiling pattern on the heater cable, heat distribution can be concentrated where it is needed. Useful to compensate for heat losses along the edges of the part being heated. Specify concentration.



Clamping Straps

Mightybands normally do not require clamping straps as the inside diameter of the coil is wound undersize for a screw fit. At times because of differences in the expansion and contraction in materials a clamping strap may be required to ensure circumferential clamping forces. Clamping straps also provide additional protection of the heater coils from accidental damage. If optional clamping strap is required, specify.

Special Coil Heater Configurations

Star Wound Coil

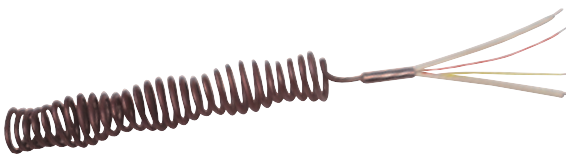

Star wound formations are usually inserted into pipes or ducts and are used to heat moving air or liquids. The offset coils create a turbulent flow. This allows the flowing material to have better contact with the heater surface, resulting in more efficient heat transfer.

Explosion or Moisture Resistant Box

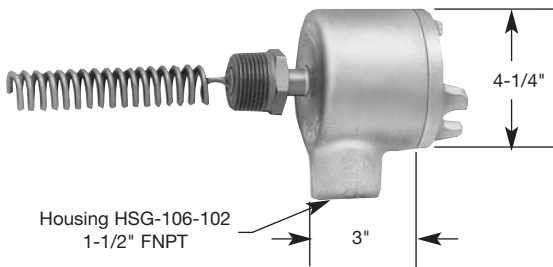

Mightyband coil heaters can be used for immersion heating and/or in-line heating of liquids, gases or air. The built-in thermocouple provides a self-contained heating unit, eliminating the need for separate thermowells, and is available with standard NPT or special fittings. The outside diameter (O.D.) of the coil must be smaller than the fitting being used for proper fit to the mating part. The wiring can be protected from hazardous environments by attaching explosion or moisture-proof boxes. Consult Tempco with your requirements.

NPT Pipe Fittings



Mightyband coil heaters can be used for immersion heating and/or in-line heating of liquids, gases or air. The built-in thermocouple provides a self-contained heating unit, eliminating the need for separate thermowells. Available with standard NPT fittings or special fittings. The outside diameter (O.D.) of the coil must be smaller than the fitting being used for proper fit to the mating part. Consult Tempco with your requirements.

Lead Orientations

LO1 Standard

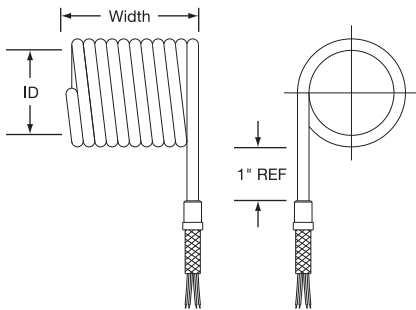

LO2

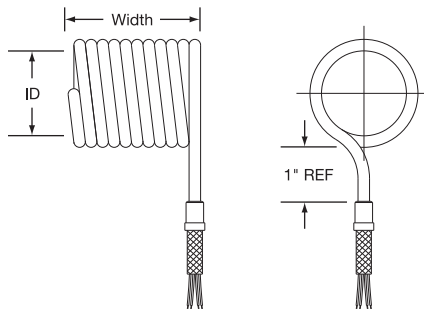

LO3

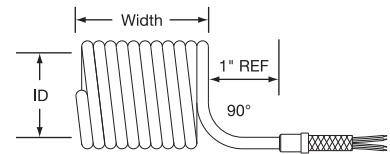

LO4

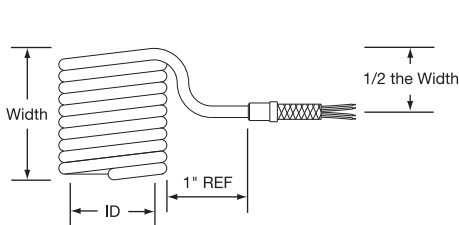

LO5

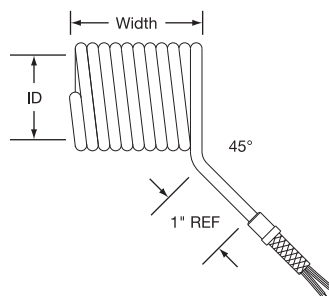

LO6

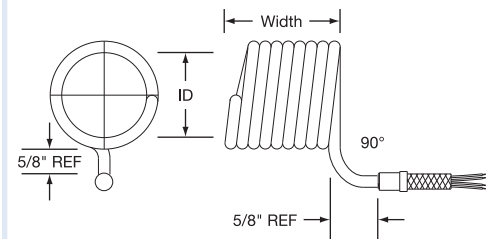

Note: Lead orientations can be custom formed. Consult Tempco with your requirements. We welcome your inquiries.



Potting Adapter Lead Terminations

- The heating element wire to lead wire transition is done within the potting adapter. Potting adapter sizes are 5/16" O.D. × 1-1/2" long for heater cable diameters 0.188" and smaller and 1/2" × 1-1/2" long for diameters above 0.188". Other diameters and lengths are available, depending on design parameters.
- When the 1/2" × 1-1/2" long potting adapter is used for high temperature applications, a special heat sink collar is also used to help keep the transition from overheating.
- All transitions use 1150°F (621°C) braze joint between the heating element wire and the flexible lead wire.
- Normally the lead wire construction is a fiberglass braided insulation rated to 482°F (250°C). For high temperature applications an MGT (mica, fiberglass, Teflon® impregnation) insulation rated to 842°F (450°C) is used. All thermocouple leads use a fiberglass insulation rated to 900°F (482°C). Lead wires are selected to meet the amperage and temperature requirements of each specific heater.

Type M__ – Plain Leads

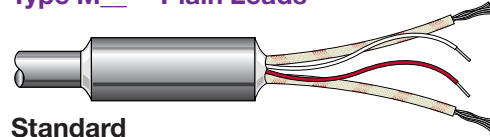

Standard

M1 – High temperature cement potting with TGGT (Teflon® tape, fiberglass, Teflon® treated fiberglass overbraid) insulated lead wire for 482°F (250°C) and silicone sealed is standard.

Optional

M2 – High temperature epoxy potting rated 450°F (232°C) with PTFE Teflon® lead wire for a better moisture seal.

Optional

M3 – High temperature cement potting with MGT (mica tape, Teflon® treated fiberglass overbraid) insulated lead wire for 842°F (450°C) and silicone sealed.



Note: Temperature at potting adapter should not exceed the specified limits.

Lead Wire Abrasion Protection Terminations

Type A__ – Stainless Steel Armor Cable

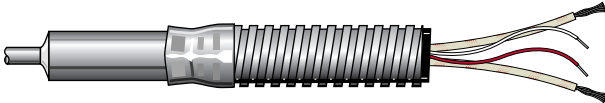

Type A1 – Rated to 482°F (250°C) – TGGT Fiberglass Wire

Type A2 – Rated to 450°F (232°C) – Teflon® Wire

Type A3 – Rated to 842°F (450°C) – MGT Fiberglass Wire

Flexible SS armor cable protects the leads against abrasion and contamination. Special plugs can be attached to heater leads and thermocouple leads.

Type C__ – Galvanized Armor Cable

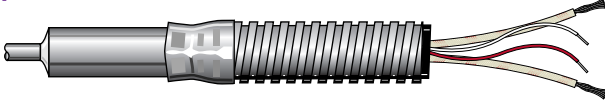

Type C1 – Rated to 482°F (250°C) – TGGT Fiberglass Wire

Type C2 – Rated to 450°F (232°C) – Teflon® Wire

Type C3 – Rated to 842°F (450°C) – MGT Fiberglass Wire

Flexible galvanized armor cable protects the leads against abrasion and contamination. Special plugs can be attached to heater leads and thermocouple leads.

Type B__ – Stainless Steel Overbraid

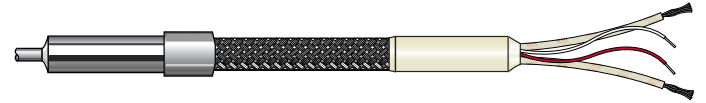

Type B1 – Rated to 482°F (250°C) – TGGT Fiberglass Wire

Type B2 – Rated to 450°F (232°C) – Teflon® Wire

Type B3 – Rated to 842°F (450°C) – MGT Fiberglass Wire

SS overbraid protects the leads against abrasion and allows more aggressive bending, which is not possible with armor cable. Special plugs can be attached to heater and thermocouple leads.

Type S__ – Fiberglass Sleeve

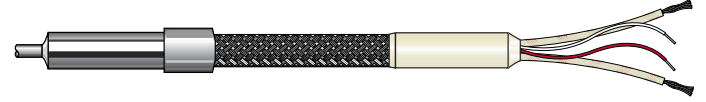

Type S1 – Rated to 482°F (250°C) – TGGT Fiberglass Wire

Type S2 – Rated to 450°F (232°C) – Teflon® Wire

Type S3 – Rated to 842°F (450°C) – MGT Fiberglass Wire

Fiberglass sleeve protects the leads against abrasion and allows more flexibility of lead wires. Special plugs can be attached to heater and thermocouple leads.

Optional Heater Cable Cold End

The availability of Tempco-Pak heaters with optional cold heater cable end depends on the electrical ratings and materials used for each heater design. Consult Tempco for the availability of these options.

Type ND – Neck Down

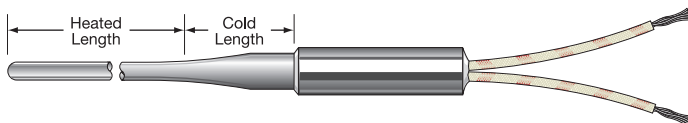

Type NW – Built-in Cold Wire

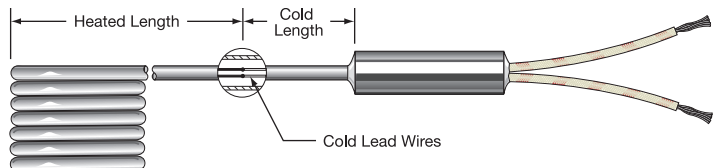



Mightyband™ Coil Heaters

Mightyband™ Coil Heaters

Heater shown with Lead Protection Type B and Lead Orientation LO1.



Standard (Non-Stock) Round Cable Heaters

Standard Cable Heaters have 304 Stainless Steel Sheath

Inside Diameter		Outside Diameter		Width		Watts	Volts	Distributed Wattage	Close Wound	Lead Protection	Lead Orientation	Part Number
in	mm	in	mm	in	mm							
½	12.7	0.808	20.5	2	50.8	340	240	yes		C1	LO2	MHC00001
½	12.7	0.808	20.5	2½	63.5	340	240	yes		C1	LO2	MHC00002
½	12.7	0.808	20.5	3	76.2	340	240	yes		C1	LO2	MHC00003
½	12.7	0.808	20.5	3½	88.9	340	240	yes		C1	LO2	MHC00004
½	12.7	0.808	20.5	3	76.2	380	240	yes		C1	LO2	MHC00005
½	12.7	0.808	20.5	3½	88.9	380	240	yes		C1	LO2	MHC00006
½	12.7	0.730	18.5	2½	63.5	450	240		yes	C1	LO1	MHC00007
½	12.7	0.764	19.4	4½	114.3	400	240	yes		C1	LO2	MHC00008
½	12.7	0.750	19.1	5½	139.7	400	240	yes		C1	LO2	MHC00009
½	12.7	0.750	19.1	6½	165.1	400	240	yes		C1	LO2	MHC00010
½	12.7	0.750	19.1	4¾	117.5	300	240		yes	C1	LO1	MHC00011
½	12.7	0.712	18.1	2	50.8	340	120		yes	C1	LO2	MHC00012
½	12.7	0.764	19.4	2½	63.5	340	120	yes		C1	LO2	MHC00013
½	12.7	0.764	19.4	3	76.2	380	120	yes		C1	LO2	MHC00014
½	12.7	0.764	19.4	3½	88.9	380	120	yes		C1	LO2	MHC00015
½	12.7	0.744	18.9	4½	114.3	400	120	yes		C1	LO2	MHC00016
½	12.7	0.744	18.9	5½	139.7	400	120	yes		C1	LO2	MHC00017
½	12.7	0.744	18.9	6½	165.1	400	120	yes		C1	LO2	MHC00018
½	12.7	0.750	19.1	4¾	117.5	300	120		yes	C1	LO1	MHC00019
❖ ⅜	15.9	0.931	23.6	2	50.8	300	240	yes		C1	LO2	MHC00020
❖ ⅜	15.9	0.931	23.6	2½	63.5	325	240	yes		C1	LO2	MHC00021
⅜	15.9	0.891	22.6	2	50.8	330	120		yes	B1	LO2	MHC00022
⅜	15.9	0.875	22.2	2	50.8	330	240		yes	B1	LO2	MHC00023
⅜	15.9	0.875	22.2	2½	63.5	330	240	yes		B1	LO2	MHC00024
⅜	15.9	0.875	22.2	3	76.2	330	240	yes		B1	LO2	MHC00025
⅜	15.9	0.875	22.2	3	76.2	380	240	yes		C1	LO2	MHC00026
⅜	15.9	0.875	22.2	3	76.2	360	240		yes	B1	LO2	MHC00027
⅜	15.9	0.875	22.2	4	101.6	360	240	yes		B1	LO2	MHC00028
⅜	15.9	0.875	22.2	4	101.6	500	240		yes	B1	LO2	MHC00029
⅜	15.9	0.875	22.2	5	127.0	500	240	yes		C1	LO2	MHC00030
❖ ⅜	15.9	0.875	22.2	6	152.4	550	240	yes		C1	LO2	MHC00031
¾	19.1	1.056	26.8	1¼	31.8	250	230		yes	M†	LO1	MHC00032
¾	19.1	1.056	26.8	1¼	31.8	125	230		yes	M†	LO1	MHC00033
¾	19.1	1.056	26.8	1¼	31.8	400	120		yes	B1	LO1	MHC00034
¾	19.1	1.000	25.4	2	50.8	365	120		yes	B1	LO1	MHC00035
¾	19.1	1.056	26.8	2	50.8	135	240		yes	B1	LO1	MHC00036
¾	19.1	1.000	25.4	3	76.2	750	240		yes	B1	LO1	MHC00037
¾	19.1	0.972	24.7	5	127.0	600	240		yes	B1	LO1	MHC00038
¾	19.1	0.992	25.2	8½	215.9	1300	240		yes	B1	LO1	MHC00039
⅞	22.2	1.181	30.0	1	25.4	400	120		yes	B1	LO1	MHC00040
⅞	22.2	1.181	30.0	1¼	31.8	250	240		yes	M†	LO2	MHC00041
❖ ⅞	22.2	1.181	30.0	2	50.8	400	240	yes		C1	LO2	MHC00042
⅞	22.2	1.181	30.0	2¾	66.7	480	240	yes		C1	LO2	MHC00043
⅞	22.2	1.181	30.0	3¾	79.4	480	240	yes		C1	LO2	MHC00044



Note: ❖ Denotes the Thermocouple Junction is located between third and fourth coil from the tip end, isolated from the sheath. † Cement Potted Teflon® insulated SPC wire. See page 5-5 for Lead Protection and page 5-4 for Lead Orientation descriptions.



Mightyband™ Coil Heaters

Standard (Non-Stock) Round Cable Heaters

Standard Cable Heaters have 304 Stainless Steel Sheath

Inside Diameter		Outside Diameter		Width		Watts	Volts	Distributed Wattage	Close Wound	Lead Protection	Lead Orientation	Part Number
in	mm	in	mm	in	mm							
7/8	22.2	1.115	28.3	2	50.8	670	120		yes	B3	LO2	MHC00045
7/8	22.2	1.125	28.6	2	50.8	670	240		yes	B1	LO2	MHC00046
7/8	22.2	1.125	28.6	2 1/2	63.5	670	240	yes		B1	LO2	MHC00047
7/8	22.2	1.125	28.6	3 3/8	79.4	670	240	yes		B1	LO2	MHC00048
❖ 7/8	22.2	1.181	30.0	2 1/2	63.5	450	240	yes		C1	LO2	MHC00049
7/8	22.2	1.181	30.0	3 3/8	92.1	550	240	yes		C1	LO2	MHC00050
7/8	22.2	1.181	30.0	4 3/16	109.5	550	240	yes		C1	LO2	MHC00051
7/8	22.2	1.181	30.0	5 1/16	134.9	650	240	yes		C1	LO2	MHC00052
7/8	22.2	1.181	30.0	6 3/16	160.3	650	240	yes		C1	LO2	MHC00053
7/8	22.2	1.181	30.0	7 1/16	185.7	650	240	yes		C1	LO2	MHC00054
❖ 7/8	22.2	1.125	28.6	3	76.2	680	240	yes		C1	LO2	MHC00055
❖ 7/8	22.2	1.125	28.6	3 1/2	88.9	700	240	yes		C1	LO2	MHC00056
7/8	22.2	1.125	28.6	3 3/8	92.1	770	240	yes		B1	LO2	MHC00057
7/8	22.2	1.125	28.6	4 3/16	109.5	770	240	yes		B1	LO2	MHC00058
7/8	22.2	1.125	28.6	5 1/16	134.9	770	240	yes		B1	LO2	MHC00059
7/8	22.2	1.125	28.6	4	101.6	775	240	yes		C1	LO2	MHC00060
7/8	22.2	1.125	28.6	6 3/16	160.3	730	240	yes		B1	LO2	MHC00061
7/8	22.2	1.125	28.6	7 1/16	185.7	730	240	yes		B1	LO2	MHC00062
❖ 7/8	22.2	1.125	28.6	5	127.0	900	240	yes		C1	LO2	MHC00063
7/8	22.2	1.105	28.1	8 5/16	211.1	730	240	yes		C1	LO2	MHC00064
7/8	22.2	1.105	28.1	9 3/16	236.5	730	240	yes		C1	LO2	MHC00065
7/8	22.2	1.105	28.1	10 3/16	261.9	730	240	yes		C1	LO2	MHC00066
❖ 7/8	22.2	1.125	28.6	6	152.4	1000	240	yes		C1	LO2	MHC00067
7/8	22.2	1.105	28.1	11 3/16	287.3	850	240	yes		C1	LO2	MHC00068
7/8	22.2	1.105	28.1	12 3/16	312.7	850	240	yes		C1	LO2	MHC00069
7/8	22.2	1.105	28.1	13 3/16	338.1	850	240	yes		C1	LO2	MHC00070
7/8	22.2	1.105	28.1	14 3/16	363.5	850	240	yes		C1	LO2	MHC00071
7/8	22.2	1.105	28.6	7	177.8	1100	240	yes		C1	LO2	MHC00072
1	25.4	1.250	31.8	1 1/2	38.1	375	120		yes	B1	LO1	MHC00073
1	25.4	1.306	33.2	1 1/2	38.1	375	240		yes	B1	LO1	MHC00074
1	25.4	1.240	31.5	2	50.8	400	120		yes	B1	LO1	MHC00075
1	25.4	1.266	32.2	2 1/2	63.5	450	120		yes	B1	LO1	MHC00076
1	25.4	1.250	31.8	8	203.2	1250	240		yes	B3	LO1	MHC00077
1 1/4	31.8	1.556	39.5	1	25.4	340	240		yes	B1	LO1	MHC00078
1 1/4	31.8	1.556	39.5	1 1/4	31.8	375	120		yes	B1	LO1	MHC00079
1 1/4	31.8	1.480	37.6	1 1/2	38.1	400	120		yes	B1	LO1	MHC00080
1 1/4	31.8	1.492	37.9	2	50.8	475	120		yes	B1	LO1	MHC00081
1 1/4	31.8	1.480	37.6	2 1/2	63.5	750	240		yes	C1	LO2	MHC00082
1 1/4	31.8	1.514	38.5	4 1/2	114.3	1250	240		yes	C3	LO2	MHC00083
1 1/4	31.8	1.534	39.0	6 1/2	165.1	1800	240		yes	C3	LO2	MHC00084
1 1/4	31.8	1.548	39.3	7	177.8	2000	240		yes	B3	LO1	MHC00085
1 1/4	31.8	1.594	40.5	8 1/2	215.9	2335	240		yes	C3	LO2	MHC00086
1 1/4	31.8	1.626	41.3	10 1/2	266.7	2500	240		yes	C1	LO2	MHC00087



Note: ❖ Denotes the Thermocouple Junction is located between third and fourth coil from the tip end, isolated from the sheath. See page 5-5 for Lead Protection and page 5-4 for Lead Orientation descriptions.

Ordering Information

See page 5-9

CONTINUED

Mightyband™ Coil Heaters

Continued from previous page...

Heater shown with
Lead Protection B and
Lead Orientation LO1.



Standard (Non-Stock) Round Cable Heaters

Standard Cable Heaters have 304 Stainless Steel Sheath

Inside Diameter		Outside Diameter		Width		Watts	Volts	Distributed Wattage	Close Wound	Lead Protection	Lead Orientation	Part Number
in	mm	in	mm	in	mm							
1½	38.1	1.806	45.9	1	25.4	400	120		yes	B1	LO1	MHC00088
		1.730	43.9	1¼	31.8	425	120		yes	B1	LO1	MHC00089
		1.742	44.2	1½	38.1	525	120		yes	B1	LO1	MHC00090
		1.742	44.2	2	50.8	475	120		yes	B1	LO1	MHC00091
		1.752	44.5	2	50.8	475	240		yes	B1	LO1	MHC00092
		1.754	44.6	2	50.8	550	240		yes	B1	LO1	MHC00093
		1.742	44.2	2½	63.5	600	120		yes	B3	LO1	MHC00094
		1.766	44.9	2½	63.5	600	240		yes	B3	LO1	MHC00095
		1.742	44.2	3	76.2	475	120		yes	B1	LO1	MHC00096
		1.732	44.0	3	76.2	875	240		yes	B1	LO2	MHC00097
		1.750	44.5	4¾	104.8	1000	240	yes		C3	LO2	MHC00098
		1.732	44.0	4	101.6	1000	240		yes	B3	LO2	MHC00099
		1.750	44.5	5½	130.2	1000	240	yes		C3	LO2	MHC00100
		1.742	44.2	5	127.0	1200	240		yes	B3	LO1	MHC00101
		1.766	44.9	6¾	155.6	1200	240	yes		B3	LO2	MHC00102
		1.750	44.5	7¾	181.0	1100	240	yes		C1	LO2	MHC00103
		1.806	45.9	6	152.4	675	120		yes	B3	LO1	MHC00104
		1.750	44.5	6	152.4	1200	240		yes	B3	LO2	MHC00105
1.766	44.8	8¾	206.4	1250	240	yes		B3	LO2	MHC00106		
1.796	45.6	9¾	231.8	1400	240	yes		B3	LO2	MHC00107		
1.826	46.4	10¾	257.2	1800	240	yes		B3	LO2	MHC00108		
1¼	44.5	1.982	50.3	1	25.4	475	120		yes	B1	LO1	MHC00109
		2.000	50.8	1½	38.1	625	240		yes	B1	LO1	MHC00110
		2.000	50.8	2	50.8	675	240		yes	B1	LO1	MHC00111
		1.982	50.3	2½	63.5	725	240		yes	B1	LO1	MHC00112
		2.056	52.2	7	177.8	2000	240		yes	B3	LO2	MHC00113
2	50.8	2.250	57.2	1¾	34.9	450	240		yes	B1	LO1	MHC00114
		2.326	59.1	6½	165.1	2400	240		yes	B3	LO1	MHC00115



Note: See page 5-5 for Lead Protection and page 5-4 for Lead Orientation descriptions.

Standard (Non-Stock) Tempco Replacement Coil Heaters for OEM Hot Runner Bushings

Standard Cable Heaters have 304 Stainless Steel Sheath

Inside Diameter in mm	Outside Diameter		Width		Watts	Volts	Distributed Wattage	Close Wound	OEM Part Number	TEMPCO Part Number
	in	mm	in	mm						
½ 12.7	0.808	20.5	3	76.2	380	240	yes		KH-52030	MHC00005
	0.808	20.5	3½	88.9	380	240	yes		KH-52035	MHC00006
	0.764	19.4	4½	114.3	400	240	yes		KH-53045	MHC00008
	0.750	19.1	5½	139.7	400	240	yes		KH-53555	MHC00009
	0.750	19.1	6½	165.1	400	240	yes		KH-53565	MHC00010
	0.764	19.4	2	50.8	340	120		yes	KH-520	MHC00012
	0.764	19.4	2½	63.5	340	120	yes		KH-52025	MHC00013
	0.764	19.4	3	76.2	380	120	yes		KH-52030	MHC00014
	0.764	19.4	3½	88.9	380	120	yes		KH-52035	MHC00015
	0.744	18.9	4½	114.3	400	120	yes		KH-53045	MHC00016
¾ 22.2	0.744	18.9	5½	139.7	400	120	yes		KH-53055	MHC00017
	0.744	18.9	6½	165.1	400	120	yes		KH-53065	MHC00018
	1.181	30.0	2½	66.7	480	240	yes		KH-826	MHC00043
	1.181	30.0	3⅞	28.6	480	240	yes		KH-82630	MHC00044
	1.181	30.0	3¾	92.1	550	240	yes		KH-82636	MHC00050
	1.181	30.0	4⅞	109.5	550	240	yes		KH-82640	MHC00051
	1.181	30.0	5⅞	134.9	650	240	yes		KH-82650	MHC00052
	1.181	30.0	6⅞	160.3	650	240	yes		KH-82660	MHC00053
	1.181	30.0	7⅞	185.7	650	240	yes		KH-82670	MHC00054
	1.105	28.1	8⅞	211.1	730	240	yes		KH-84380	MHC00064
1¼ 31.8	1.105	28.1	9⅞	236.5	730	240	yes		KH-84390	MHC00065
	1.105	28.1	10⅞	261.9	850	240	yes		KH-84310	MHC00066
	1.105	28.1	11⅞	287.3	850	240	yes		KH-85311	MHC00068
	1.105	28.1	12⅞	312.7	850	240	yes		KH-85312	MHC00069
	1.105	28.1	13⅞	338.1	850	240	yes		KH-85313	MHC00070
	1.105	28.1	14⅞	363.5	850	240	yes		KH-85314	MHC00071
	1.480	37.6	2½	63.5	750	240		yes	KH-1225	MHC00082
1.514	38.5	4½	114.3	1250	240		yes	KH-1245	MHC00083	
1.534	39.0	6½	165.1	1800	240		yes	KH-1265	MHC00084	
1.594	40.5	8½	215.9	2335	240		yes	KH-1285	MHC00086	
1.626	41.3	10½	266.7	2500	240		yes	KH-12105	MHC00087	



Note: All OEM Replacement Heaters have round cable, Type "C" galvanized armor cable lead wire protection and LO2 lead orientation (see page 5-4).

Ordering Information

Standard Heaters

Order by Part Number for standard heaters listed in Tables on pages 5-6 through 5-9.

Custom Engineered/Manufactured Heaters

An electric heater can be very application specific; for sizes, ratings and terminations not listed, **TEMPCO** will design and manufacture a Mightyband heater to meet your requirements. **Standard lead time is 3 weeks.**

Please Specify the following:

- Watts
- Volts
- Coil I.D.
- Coil width (length)
- Distributed wattage if required
- Sheath material— 304 stainless steel or Incoloy® 600
- Sheath Diameter if necessary
- Length of internal nickel cold, or if a neck down design, length of cold section. See page 5-5.
- Thermocouple if required— Type J or K
- Thermocouple Junction—Grounded or Ungrounded. If ungrounded, specify location.
- Transition type: M1, M2, M3, A1, A2, A3, B1, B2, B3, C1, C2, C3, S1, S2 or S3. See page 5-5.
- Lead orientation: LO1, LO2, LO3, LO4, LO5, or LO6. See page 5-4.
- Lead length if other than 24"
- Supply a sketch or drawing.

WARNING: Cancer and Reproductive Harm - www.P65Warnings.ca.gov.

Coil & Cable Heaters



Mightyband™ (Square Cable)

Mightyband™ Coil Heaters with Square/Rectangular MI Cable

TEMPCO offers a square sheathed, mineral insulated, coiled nozzle heater with a built-in-thermocouple. The unique feature of the 1/8" square sheath is a larger sheath contact area as compared to its round sheathed counterpart, allowing for faster start-up cycles. The ANSI Type J standard or optional Type K thermocouple normally has a grounded junction. However, an optional ungrounded junction is available. Heaters can be formed into a compact coiled nozzle heater supplying a full 360° of heat to the distributed wattage coil. The low mass of the heater allows quick response to both heating and cooling.



Specifications

- Resistance tolerance: ±10%
- Wattage tolerance: ±10%
- Maximum Wattage: 720 watts (for 240 volt heaters)
300 watts (for 120 volt heaters)
- Maximum operating temperature: 1500°F (816°C)
- Maximum Watt density: 134 watts/in² applied to nozzle
- Physical Dimensions: 1/8" square
(except non-heated tail section, which is 1/8" round)
- Length of non-heated section: 1" to 6" (specify when ordering)
- Potting Adapter: 5/16" O.D. × 1-1/2" long
Standard Lead Length as specified in table below (if other than standard, specify)

Standard Features

- * Standard lead wire construction is a fiberglass braided insulation with stainless steel overbraid suitable for 482°F (250°C). Optional constructions using Teflon® insulation or armor cable are available on request.
- * The standard wire to M.I. cable transition area (potting adapter) is temperature rated to 450°F (232°C). High temperature 842°F (450°C) is optional.
- * The ANSI Type J standard or optional Type K thermocouple junction can be grounded at the tip (the end farthest from transition area) or ungrounded anywhere along the length of the heater.
- * Heaters can be supplied with optional stainless steel clamping straps, which provide additional circumferential clamping forces and protection of the heater coils from accidental damage.
- * All Mightyband coil heaters are available with one (1) of six (6) different lead orientations (LO) as shown on Page 5-4. Other custom lead orientations can be manufactured to suit. Specify lead orientation when ordering.
- * Can be supplied with optional grounding wire upon special request.

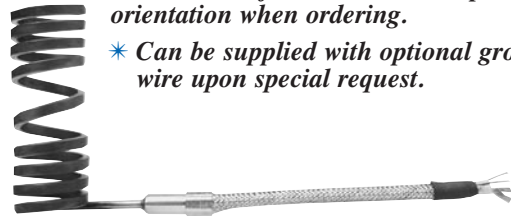

Standard (Non-Stock) 1/8" Square Tempco-Pak Cable Heaters (Non-heated tail section is 1/8" round)

Standard Cable Heaters have 304 Stainless Steel Sheath

Coil I.D.		Closed Coil Width		Stretched Width		Built-In T/C	Voltage	Wattage	Standard Lead Length		Lead Protection	Lead Orientation	Part Number
in	mm	in	mm	in	mm				in	mm			
.500	12.7	2.00	50.8	2.5	63.5	yes	240	450	40	1016	C†	L01	MHC00116
.500	12.7	2.50	63.5	4.6	116.8	yes	240	300	48	1219	A†	L05	MHC00117
.750	19.1	1.25	31.8	—	—	yes	230	125	48	914	M†	L04	MHC00118
.750	19.1	1.25	31.8	—	—	yes	230	250	48	914	M†	L04	MHC00119
.750	19.1	1.25	31.8	1.5	38.1	yes	240	300	48	1219	S2	L05	MHC00120
.750	19.1	0.95	24.1	—	—	yes	240	250	72	1829	M1	L01	MHC00121
.968	24.6	0.95	24.1	—	—	yes	240	250	72	1829	M2	L01	MHC00122
.968	24.6	1.58	40.1	—	—	yes	240	300	72	1829	M2	L01	MHC00123

† Cement Potted Teflon® insulated SPC wire

Ordering Information

Standard Heaters

Order by Part number for standard heaters listed above for runnerless plastic injection molding, hot sprue bushings and nozzles.

If not otherwise specified, all Mightyband heaters are supplied with close wound coiling pattern, Type L01 lead orientation (see page 5-4), 24" of leads and 20" of stainless steel overbraid with Type J thermocouple. If longer leads are required, please specify.

Custom Engineered/Manufactured Heaters

An electric heater can be very application specific; for sizes, ratings and terminations not listed, TEMPCO will design and manufacture a Mightyband heater to meet your requirements. **Standard lead time is 3 weeks.**

Please Specify the following:

- Inside Diameter
- Width (Length)
- Specify width as closed or stretched
- Wattage
- Voltage
- Length of non-heated tail section
- Lead length
- Lead Orientation (see page 5-4)
- Lead Transition (see page 5-5)
- Lead protection (see page 5-5)
- Thermocouple Type—if required

⚠ WARNING: Cancer and Reproductive Harm - www.P65Warnings.ca.gov.

Tempco Direct Replacement Heaters for OEM Hot Runner Systems Square & Rectangular Cable

Design Features

- * 1/8" square 304 Stainless Steel M.I. cable
- * Type J ungrounded thermocouple junction in the midsection of the coil heater
- * 48" of leads and 44" of SS armored cable

Coil I.D.		Coil Width		Watts	Volts	OEM	TEMPCO
in	mm	in	mm			Part Number	Part Number
.500	12.7	4.625	117.5	300	120	SSTC-31	MHC00124
.500	12.7	4.625	117.5	300	240	SSTC-32	MHC00125
.500	12.7	2.500	63.5	450	240	SSTC-42	MHC00126



Design Features

- * 1/8" square 304 Stainless Steel M.I. cable
- * Type J ungrounded thermocouple junction in the midsection of the coil heater
- * 48" of leads and 44" of SS armored cable

Coil I.D.		Coil Width		Watts	Volts	OEM	TEMPCO
in	mm	in	mm			Part Number	Part Number
.500	12.7	4.625	117.5	300	120	SSTC-31-90	MHC00127
.500	12.7	4.625	117.5	300	240	SSTC-32-90	MHC00128
.500	12.7	2.500	63.5	450	240	SSTC-42-90	MHC00129

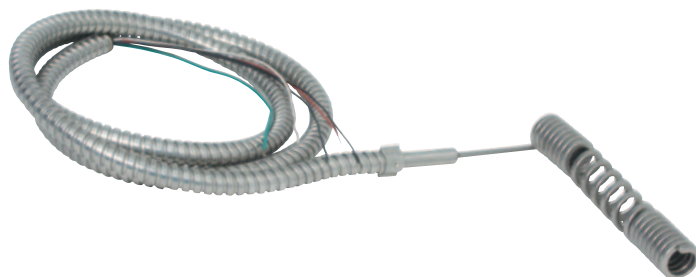

Gated, Flow-Through Hot Sprue Bushing Heaters

Design Features

- * .110" x .160" rectangular or 1/8" square 304 Stainless Steel M.I. cable
- * No thermocouple
- * 42" of leads and 38" of high temperature fiberglass sleeving

Coil I.D.		Coil Width		Watts	Volts	OEM	TEMPCO
in	mm	in	mm			Part Number	Part Number
1.250	31.8	2.625	66.7	800	240	SCH0001	HHC00001
1.250	31.8	1.750	44.5	600	240	SCH0002	HHC00002
.625	15.9	1.000	25.4	225	240	SCH0003	HHC00003
.750	19.1	1.750	44.5	315	240	SCH3142	HHC00004
.750	19.1	2.625	66.7	315	240	SCH3242	HHC00005

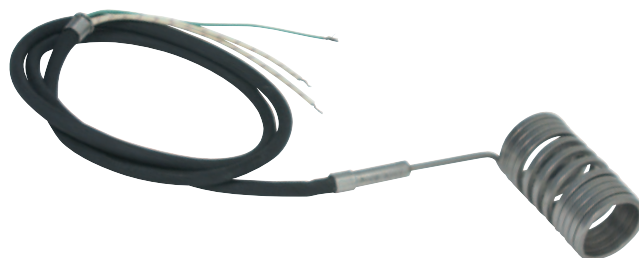

Heated Nozzle Locator Heaters

Design Features

- * 1/8" square 304 Stainless Steel M.I. cable
- * Type J ungrounded thermocouple junction at tip of coil heater
- * 36" of leads and 34" SS wire braid

Coil I.D.		Coil Width		Watts	Volts	OEM	TEMPCO
in	mm	in	mm			Part Number	Part Number
.500	12.7	1.450	36.8	250	240	SSTC-62-90	MHC00130
.500	12.7	1.950	49.5	250	240	SSTC-72-90	MHC00131

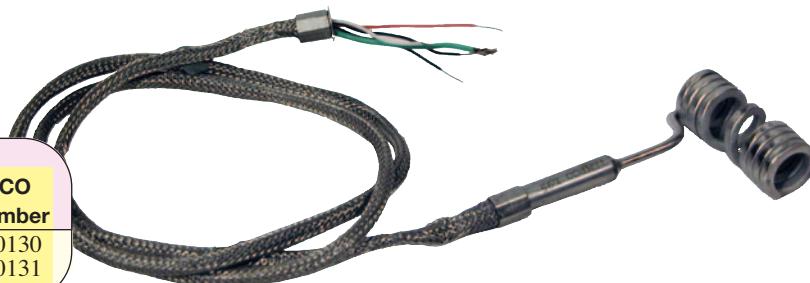

OEM Replacement Heaters for Externally Heated Manifold Systems

Rectangular Cable Heaters



Design Features

- * Systems with .250" diameter flow path nozzle assemblies
- * Rectangular (0.110" x 0.160") 304 Stainless Steel M.I. cable
- * Ungrounded Type J thermocouple
- * 36" of leads and 34" of high temperature fiberglass sleeving

Coil I.D. in mm	Coil Width		Watts	Volts	OEM	TEMPCO
	in	mm			Part Number	Part Number
.625 15.9	2.000	50.8	300	240	SCH0081	MHC00132
	2.500	63.5	350	240	SCH0082	MHC00133
	3.000	76.2	400	240	SCH0083	MHC00134
	3.500	88.9	425	240	SCH0084	MHC00135
	4.000	101.6	500	240	SCH0085	MHC00136
	5.000	127.0	500	240	SCH0086	MHC00137
	6.000	152.4	550	240	SCH0087	MHC00138

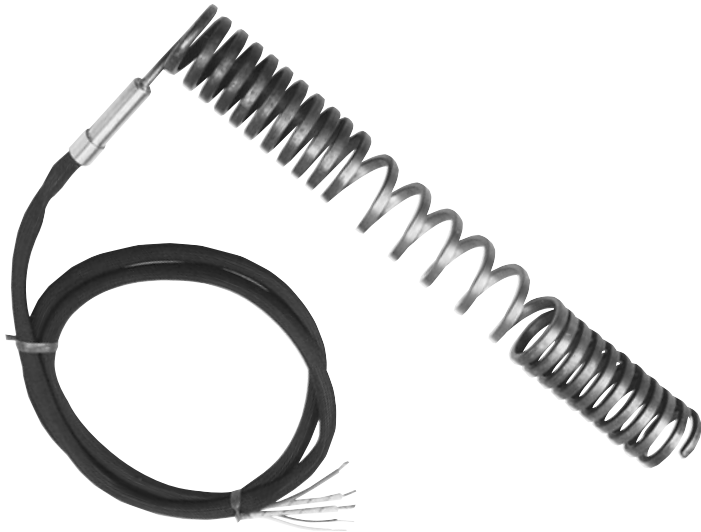

Design Features

- * Systems with .375" diameter flow path nozzle assemblies
- * Rectangular (0.110" x 0.160") 304 Stainless Steel M.I. cable
- * Ungrounded Type J thermocouple
- * 36" of leads and 34" of high temperature fiberglass sleeving

Coil I.D. in mm	Coil Width		Watts	Volts	OEM	TEMPCO
	in	mm			Part Number	Part Number
.875 22.2	2.125	54.0	400	240	SCH0088	MHC00139
	2.625	66.7	450	240	SCH0089	MHC00140
	3.125	79.4	550	240	SCH0090	MHC00141
	3.625	92.1	700	240	SCH0091	MHC00142
	4.125	104.8	800	240	SCH0092	MHC00143
	5.125	130.2	900	240	SCH0093	MHC00144
	6.125	155.6	1000	240	SCH0094	MHC00145
	7.125	181.0	1100	240	SCH0095	MHC00146

Tempco Replacement Heaters and Thermocouples for OEM Hot Runner Nozzles

Design Features: Heater

- * Systems with 0.024" nozzle gate diameter
- * Rectangular (0.110" x 0.160") 304 Stainless Steel M.I. cable
- * Separate thermocouple required (see table below for part number)
- * 36" of leads and 34" of high temperature fiberglass sleeving

Design Features: Thermocouple

- * Type J
- * 1/16" OD, 304 Stainless Steel sheath
- * See Section 14 page 14-44 for complete thermocouple details



Coil I.D. in mm	Coil Width		Watts	Volts	Heater		Thermocouple	
	in	mm			OEM Part Number	TEMPCO Part Number	OEM Part Number	TEMPCO Part Number
.750 19.1	1.437	36.5	250	240	SCH0060	HHC00006	TCG0060	TCR00017
	1.937	49.2	300	240	SCH0061	HHC00007	TCG0061	TCR00018
	2.437	61.9	350	240	SCH0062	HHC00008	TCG0062	TCR00019
	2.937	74.6	400	240	SCH0063	HHC00009	TCG0063	TCR00020
	3.437	87.3	425	240	SCH0064	HHC00010	TCG0064	TCR00021
	4.437	112.7	500	240	SCH0065	HHC00011	TCG0065	TCR00022
	5.437	138.1	500	240	SCH0066	HHC00012	TCG0066	TCR00023

Tempco Replacement Heaters for OEM Hot Runner Systems

Rectangular Cable Heaters

Sprue Bushing Heaters



Design Features

- * 5/8" ID Coil
- * Rectangular (0.110" x 0.160") 304 Stainless Steel M.I. cable
- * 36" of leads and 32" of sleeving

Coil I.D. in mm	Coil Width		Watts	Volts	OEM	TEMPCO
	in	mm			Part Number	Part Number
.625 15.9	2.000	50.8	300	240	SF-620	MHC00267
	2.500	63.5	350	240	SF-625	MHC00268
	3.000	76.2	400	240	SF-630	MHC00269
	3.500	88.9	400	240	SF-635	MHC00270
	4.000	101.6	460	240	SF-640	MHC00271
	5.000	127.0	610	240	SF-650	MHC00273
	6.000	152.4	690	240	SF-660	MHC00274

Design Features

- * 7/8" ID Coil
- * Rectangular (0.110" x 0.160") 304 Stainless Steel M.I. cable
- * 48" of leads and 44" of sleeving



Coil I.D. in mm	Coil Width		Watts	Volts	OEM	TEMPCO
	in	mm			Part Number	Part Number
.875 22.2	2.000	50.8	400	240	SF-820	MHC00275
	2.500	63.5	460	240	SF-825	MHC00276
	3.000	76.2	610	240	SF-830	MHC00277
	3.500	88.9	610	240	SF-835	MHC00278
	4.000	101.6	610	240	SF-840	MHC00279
	4.500	114.3	690	240	SF-845	MHC00280
	5.000	127.0	690	240	SF-850	MHC00281
	6.000	152.4	725	240	SF-860	MHC00282
7.000	177.8	725	240	SF-870	MHC00283	

Runnerless Mold Cartridge Heaters

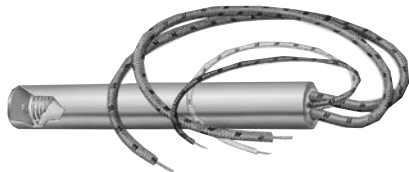

OEM Replacement
Runnerless Molding
Pennybottom Cartridge Heaters

See Section 2 pages 2-24 through 2-26



Tempco Replacement Heaters for OEM Hot Runner Systems

Square Cable Heaters

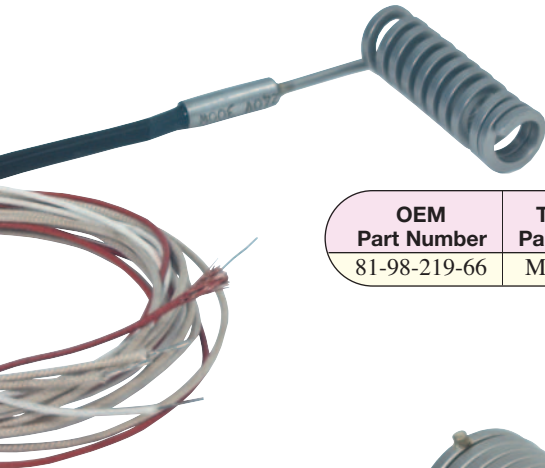

OEM Part Number	TEMPCO Part Number
81-98-219-66	MHC00457

Design Features

- * 300 Watts, 240 Volts
- * .100" square 304 Stainless Steel M.I. cable
- * 3/8" ID x 2" stretched width
- * Termination Type S1
- * Lead Orientation LO1 with 3/4" reference cold length
- * 48" of leads and 6" fiberglass sleeve
- * Built-in Type J ungrounded thermocouple junction at tip of the heater
- * Adapter Size: 1/4" O.D. x 7/8" long

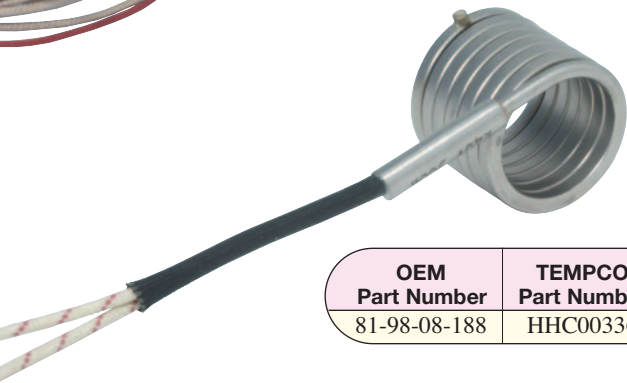

OEM Part Number	TEMPCO Part Number
81-98-08-188	HHC00336

Design Features

- * 300 Watts, 240 Volts
- * .132" square 304 Stainless Steel M.I. cable
- * .997" ID x 1.12" nominal closed width
- * Termination Type S1
- * Lead Orientation LO1 with zero reference length and 1" cold tail length
- * 10 feet of leads and 2" fiberglass sleeve
- * Adapter Size: 1/4" O.D. x 1" long

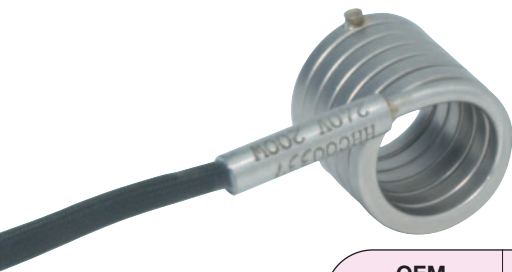

OEM Part Number	TEMPCO Part Number
81-98-06-182	HHC00337

Design Features

- * 200 Watts, 240 Volts
- * .132" square 304 Stainless Steel M.I. cable
- * .747" ID x 1" nominal closed width
- * Termination Type S1
- * Lead Orientation LO1 with zero reference length and 1" cold tail length
- * 10 feet of leads and 2" fiberglass sleeve
- * Adapter Size: 1/4" O.D. x 1" long

Tubular Hot Runner Mold Heaters

SEE PAGE 10-13 IN THE TUBULAR HEATER SECTION.

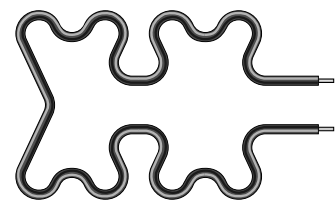
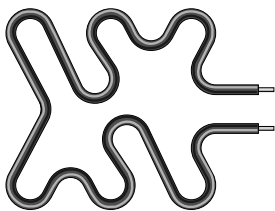

OEM Replacement Oxygen Analyzer Heaters

Oxygen Analyzer Heaters (Westinghouse Probes)

Design Features

- * Inconel® 600 Seamless Nickel Alloy Sheath Material for Process temperatures up to 1400°F (760°C)
- * Minimum 99.4% purity compacted MgO Insulation Material
- * 300 Series Stainless Steel Potting Adapter filled with Stycast epoxy for 500°F continuous use
- * Standard heater lengths are 13", 18", 36" and 72" long. Longer length heaters such as 108" and 144" are also available.

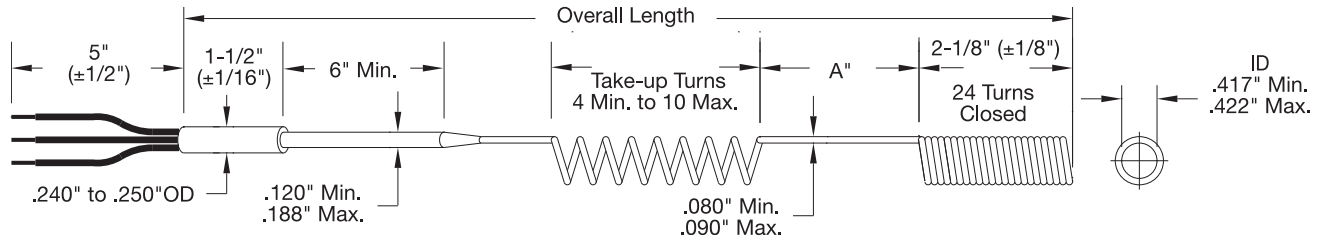

"OA" Length		"A" Length		Watts	Volts	OEM Part Number	TEMPCO Part Number
in	mm	in	mm				
13.0	330	0	0	340	115	263C303HO-6	HHF00009*
18.5	470	4	102	340	115	263C303HO-1	HHF00004
36.5	927	4	102	340	115	263C303HO-2	HHF00005
72.5	1842	4	102	340	115	263C303HO-3	HHF00006

Lead Wires: Teflon® insulated 600 Volt 18 ga. Nickel or Silver Plated Copper Wire (Stranded with Black or Brown)

Grounding Wire: 18 ga. Nickel or Silver Plated Copper, Stranded with Green or Purple Teflon® insulation/600 Volt Rated



Note: *Part Number HHF00009 does not have a straight length section "A." The .080"/.090" diameter heater cable is coiled to .417"/.422" ID all the way to the neck down and stretched except for the front 24 turns of coils.

Oxygen Analyzer Heaters (Enotec Probes)

Design Features

- * Inconel® 600 Seamless Nickel Alloy Sheath Material for Process temperatures up to 1400°F (760°C)
- * Minimum 99.4% purity compacted MgO Insulation Material
- * 300 Series Stainless Steel Potting Adapter filled with Stycast epoxy for 500°F continuous use
- * Standard heater lengths are 13", 18", 36" and 72" long.

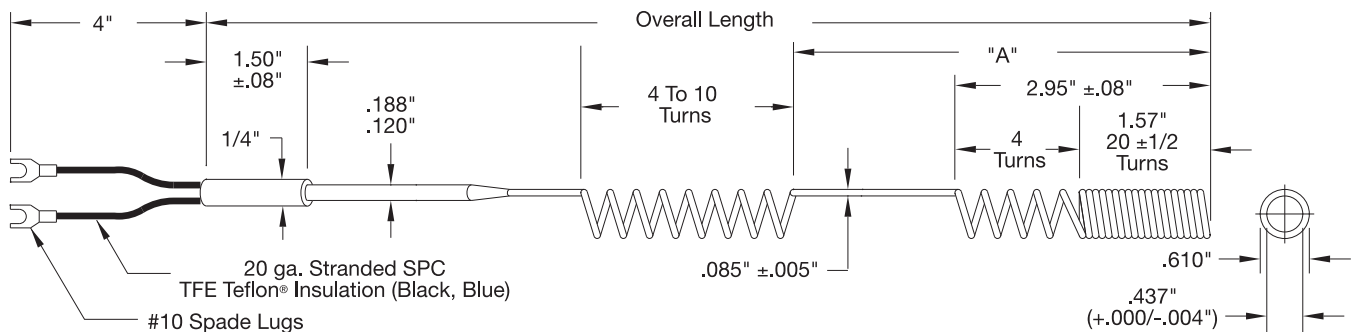

"OA" Length		"A" Length		Watts	Volts	OEM Part Number	TEMPCO Part Number
in	mm	in	mm				
13.15	334	4.23	107	340	115	HEI-132X	HHC00304
18.27	464	8.07	205	340	115	HEI-2001	HHC00199
36.50	927	8.07	205	340	115	HEI-2002	HHC00200
72.80	1849	8.07	205	340	115	HEI-2003	HHC00303

Lead Wires: Teflon® insulated 20 ga. Stranded Silver Plated Copper Wire (color coded one black and one blue)

Termination: #10 Uninsulated Spade Lug

Oxygen Analyzer Heaters with .153" Diameter Cable

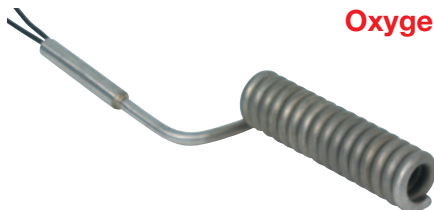

Tempco can also supply oxygen analyzer heaters for 240V, 520W with 0.153" diameter Inconel® 600 sheath, 0.394" ID x 2.75" coil width, with overall lengths of 6.29", 13.18", 17.12", 23.41", 32.86", 43.10", 62.39" and 80.11".
Consult Tempco with your requirements – we welcome your inquiries.

Cable HEATERS

CUSTOM ENGINEERED

FORMED

&

STRAIGHT

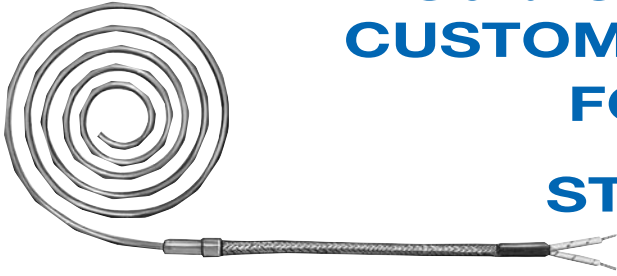

Spiral-wound Tempco-Pak heater cables are low profile and capable of generating high operating temperatures in restricted areas. The built-in thermocouple eliminates the need for a separate thermocouple. Works especially well as an alternative heat source for flat surface heating applications where other types of heaters cannot be used due to space restrictions. Consult Tempco with your requirements.



Compression fittings are available on straight cable heaters of various diameters (1/8", 3/16", 1/4", 5/16" and 3/8"). This fitting enables adjustment of the insertion length during installation. Compression fittings are available in Brass or Stainless Steel with standard male NPT threads. When ordering, specify heater sheath material, NPT size and material for compression fittings, insertion length, thermocouple type and type of junction (grounded or ungrounded), thermocouple and heater lead lengths, watts and volts. Optional—thermocouple location and cooler or unheated cable lengths. Consult Tempco with your requirements.



Sinuated (formed) Tempco-Pak heater cables are low profile and capable of generating high operating temperatures in restricted areas. The built-in thermocouple eliminates the need for a separate thermocouple. Works especially well as an alternative heat source for flat surface heating applications where other types of heaters cannot be used due to space restrictions. The sinuated cable can also be formed to conform to a cylindrical inside or outside surface. Consult Tempco with your requirements.

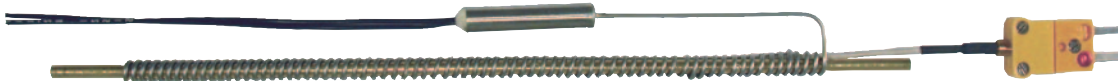

Lab Equipment: Gas Analyzer Heaters

This heater heats gas analyzer samples quickly and uniformly. Low mass construction allows for a fast cool down, increasing cycle times. Adding a T/C or RTD to an assembly is not a problem. Straight lengths are also available for manual custom bending requirements.

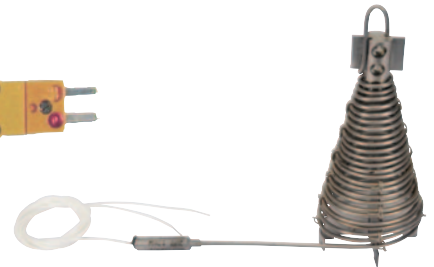



Miniature-Coil heaters are made for special applications. Cable diameter is less than .100". They work especially well as an alternative heat source for demanding and high temperature applications where other types of heaters have failed. Available with cooler or unheated cable section toward lead end. Consult Tempco with your requirements.

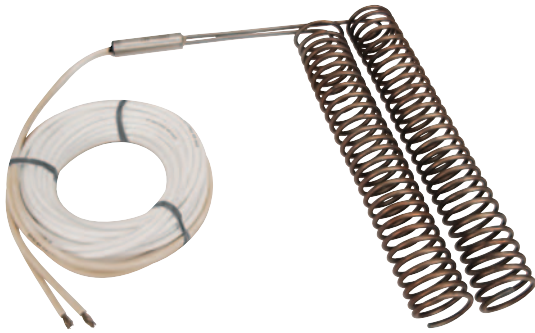
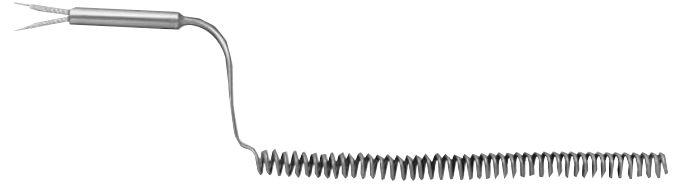

Stainless steel mounting flange is 1" diameter x .060" thick with two 1/4" holes on a 3/4" bolt circle. When ordering, specify location of mounting flange, cable diameter, length, sheath material, thermocouple type and type of junction (grounded or ungrounded), thermocouple and heater lead lengths, watts and volts—optional: thermocouple location and cooler or unheated cable lengths. Consult Tempco with your requirements.

NOTE: Mounting flange to be located over a cold or cooler section.



Gas or Air Heaters rated 1050 watts at 240 volts. One end has 1/4" MNPT and the other end has 1/4" FNPT so that you can have a series of the heaters for higher wattage requirements. It has 1-1/8" OD x 8" long stainless steel tubing body with 9-3/8" overall length.

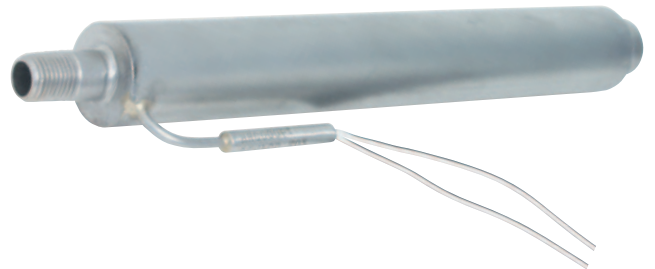

Star-Wound Coil

Star wound formations are usually inserted into pipes or ducts and are used to heat moving air or liquids. The offset coils create a turbulent flow. This allows the flowing material to have better contact with the heater surface resulting in more efficient heat transfer.



Tempco-Pak Heaters — Design Constructions

Tempco-Pak Heaters with Straight Wire

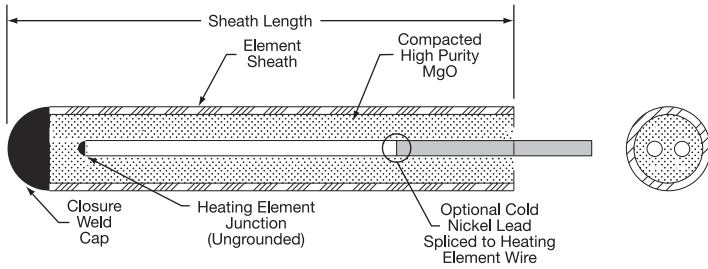

Tempco-Pak heaters are made from M.I. cable having 2 straight heating element wires insulated from the sheath by high purity MgO.

Available in nominal sheath diameters from 0.040" to 0.375" (1mm to 9.5mm) in 304 stainless steel and Inconel® 600 for Tempco-Pak heaters with straight wire. Optional cold nickel lead spliced to heating element wire is available in 0.125" diameter or larger depending on conductor material.

Nominal Sheath O.D.		Maximum Heater Length		Nominal Sheath O.D.		Maximum Heater Length	
in	mm	ft	meters	in	mm	ft	meters
.040	1.00	25	7.6	.188	4.77	100	30.5
.063	1.60	70	21.0	.250	6.35	59	18.0
.125	3.18	120	36.5	.312	7.93	38	11.5
.163	4.14	130	39.6	.375	9.53	26	8.0



Note: Consult Tempco for diameters other than those listed above.

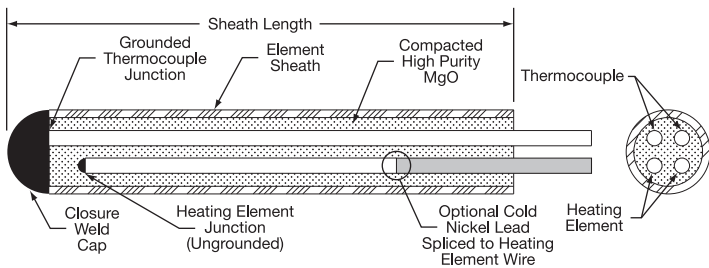

Tempco-Pak Heaters with Straight Wire and Built-In Thermocouple

Tempco-Pak heaters with 0.125" or larger diameter are also made from M.I. cable having 2 straight heating element wires and 2 straight thermocouple wires insulated from the sheath by high purity MgO. Optional cold nickel lead spliced to heating element wire is available in 0.125" diameter or larger depending on conductor material.

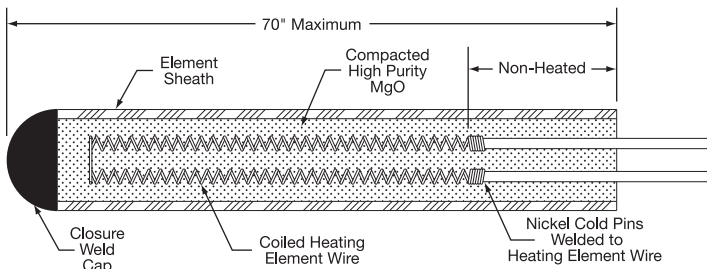

Tempco-Pak Heaters with Helically Coiled Wire

Hi-Density Tempco-Pak heaters are manufactured from sheathed M.I. cable having 2 coiled heating element wires or 2 coiled heating element wires and 2 straight thermocouple wires. The non-heated portion has the largest possible diameter solid nickel cold pins attached to the heating element wires, providing maximum current carrying capacity within the same continuous sheath.

Available in nominal sheath diameters from 0.120" to 0.153" (3.05 mm to 3.9 mm) including 0.125" O.D., 0.132" O.D. and 0.143" O.D. Tempco also manufactures 0.110" x 0.160" rectangular cable as well as 0.125" square cable.

Maximum sheath length including non-heated section is 70 inches (1778 mm).

Optional Built-in Thermocouple is ANSI Type J or Type K grounded at tip (end farthest from cold end) or ungrounded anywhere along heater length for .125" diameter and larger.



Tempco-Pak Cable Heaters

The densely compacted MgO insulation used in Tempco-Pak heaters produces excellent high temperature insulation resistance and dielectric strength. Heaters can be manufactured with the optional cold nickel leads internally spliced to the heating element wires within the same continuous sheath.

Generally speaking, there is very little temperature difference between the sheath and heater wires. Tempco recommends not exceeding 150 watts per square inch of sheath surface area with the sheath operating temperature at 1000°F (537°C) or less. As temperature increases above 1000°F, the maximum watt density should be decreased.

The maximum recommended operating temperature is 1800°F (982°C) with Inconel® 600 sheath and ANSI Type K thermocouple if required. Heater life in any specific situation or application is impossible to predict. However, heater life generally decreases as temperature and/or the number of thermal cycles increases.

Tempco-Pak heaters are flexible and can be readily formed or bent by hand or production machinery, with the minimum bend radius equal to twice the sheath diameter. The heater sheath can be welded, brazed or soldered without changing its electrical characteristics.

Performance Ratings

Watt Density: 75 watts per square inch of sheath surface area maximum with factory approval

Maximum temperature: 1500°F (815°C) for 304 stainless steel sheath
1800°F (982°C) for Inconel® 600 sheath

Specifications

Electrical

Resistance: ±10% unless otherwise specified

Voltage: 120V and 240V standard

Thermocouples: ANSI Type J to 1500°F (815°C)
Type K to 1800°F (982°C)

All thermocouples and their junctions are internal to the heater sheath. A grounded junction at the heater tip is standard. An ungrounded junction anywhere along the heater's length is optional. Available in sheath diameters .125" and larger.

Dimensional

Heater cable diameters: 0.040", 0.062", 0.115", 0.120",
0.125", 0.132", 0.153", 0.163",
0.174", 0.188", 0.220", 0.250".
Others available upon request.

Cable diameter tolerance: ±.005

Heater length tolerance: 0 to 6" (+1/8", -0), 6 to 18" (+1/4", -0)
18 to 24" (+3/8", -0), 24 to 120" (+3/4", -0)
120 to 300" (±1")

Transition and Termination Construction Specifications

Transition (potting) adapters: 5/16" O.D. × 1-1/2" long for heater cable 0.163" diameter and smaller. 1/2" O.D. × 1-1/2" long for heater cable diameters above 0.163"

Transition Temperature Rating: Standard transition is rated to 482°F (250°C).

Optional High Temperature Transition is rated to 842°F (450°C).

Standard heater lead wire insulation is TGGT (Teflon®, double fiberglass, Teflon® impregnation), which is rated to 482°F (250°C).

Optional high temperature insulation is MGT (mica, fiberglass, Teflon® impregnation) which is rated to 842°F (450°C).

Thermocouple: Standard leads use a fiberglass insulation rated to 900°F (482°C). Teflon® insulation is available upon request.

Optional lead protection: Stainless steel overbraid or galvanized armor cable.

Ordering Information

Standard Heaters

Order by Part Number for standard heaters listed in Tables on pages 5-21 through 5-23.

Part Numbers are for heaters with standard lead length of 24" unless otherwise specified. Longer lead length as well as stainless steel wire braid protection or armored cable protection are available upon request.

Heaters under 72" (1829 mm) will be shipped straight; longer heaters will be shipped in coils a minimum of 24" (610 mm) in diameter.

Custom Engineered/Manufactured Heaters

For sizes, ratings and terminations not listed, **TEMPCO** will design and manufacture a Tempco-Pak heater to meet your requirements. **Standard lead time is 3-4 weeks.**

Please Specify the following:

- Wattage and Voltage
- Sheath Diameter
- Heater length
- Sheath material— 304 stainless steel or Inconel® 600
- Length of internal nickel cold, or if a neck down design, length of cold section. See page 5-5.
- Thermocouple if required— Type J or K
- Thermocouple Junction— Grounded or Ungrounded. If ungrounded, specify location (.115" and larger).
- Transition type: M1, M2, M3, A1, A2, A3, B1, B2, B3, C1, C2, C3, S1, S2 or S3. See page 5-5.
- Lead length if other than 24"
- Supply a sketch or drawing.

⚠ WARNING: Cancer and Reproductive Harm - www.P65Warnings.ca.gov.

(800) 323-6859 • Email: sales@tempco.com

Coil & Cable Heaters



Tempco-Pak Heaters

.125 & .153 Diameter Cable Heaters With and Without Thermocouples

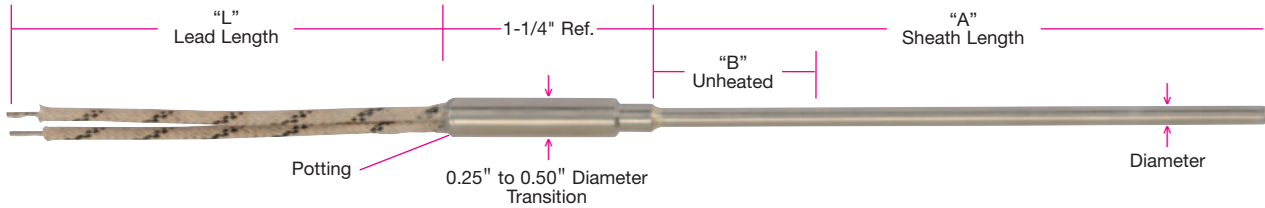

Design Features

- * For temperatures up to 1500°F (815°C) with 304 SS sheath or 1800°F (982°C) with Inconel 600 sheath.
- * Heater can be formed into almost any shape.
- * Available with optional type J or K thermocouples.
- * Watt densities up to 40 watts /square inch and as high as 75 watts/square inch in certain applications.

Ordering Code:

1	2	3	4	5	6	7	8	9	10	11	12	13	14
<input type="checkbox"/>	<input type="checkbox"/>	<input type="checkbox"/>	<input type="checkbox"/>	<input type="checkbox"/>	<input type="checkbox"/>	<input type="checkbox"/>	<input type="checkbox"/>	<input type="checkbox"/>	<input type="checkbox"/>	<input type="checkbox"/>	<input type="checkbox"/>	<input type="checkbox"/>	<input type="checkbox"/>
	H	S											

Heater Type BOX 1
M = With thermocouple
H = Without thermocouple

Diameter BOX 2
F = .125"
G = .153"

Thermocouple Type BOX 3
0 = No Thermocouple
J = Type J Thermocouple
K = Type K Thermocouple

Thermocouple Junction BOX 4
0 = No Thermocouple
G = Grounded at Tip
U = Ungrounded at Tip
M = Ungrounded in the Middle

Sheath Material BOX 5
B = 304 SS
A = Inconel® 600

"A" Dimension BOX 6
(Heater Length)
 Whole inches
00 to **99**

"A" Dimension BOX 7
(Heater Length)
 Fractional inches
0 = 0" **4** = 1/2"

"B" Dimension BOX 8
(Unheated Length)
 Whole inches
0 to **9**

Wattage BOX 9
 Examples: Enter **090** for 90 watts
 Enter **250** for 250 watts

Voltage BOX 10
1 = 120 Volts
2 = 240 Volts

"L" Dimension BOX 11
 Whole inches
001 to **999**

Lead Insulation BOX 12
M = Plain Leads
B = Stainless Steel Overbraid
C = Galvanized Armor Cable
A = Stainless Steel Armor Cable
S = Fiberglass Sleeve

Transition Temperature Rating BOX 13
1 = 482°F (250°C) — TGGT Wire with High Temperature Cement Potting
2 = 392°F (200°C) — TFE Wire with Epoxy Potting
3 = 842°F (450°C) — MGT Wire with High Temperature Cement Potting

Special Requirement BOX 14
X = Specify
0 = None

Ordering Information

Cable Heaters are offered with the options listed in the worksheet. Create an ordering code by filling in the boxes with the appropriate number and/or letter designation for your requirements, and a part number will be assigned.

⚠ WARNING: Cancer and Reproductive Harm - www.P65Warnings.ca.gov.

Standard (Non-Stock) Round Straight Tempco-Pak Cable Heaters

Part numbers are for 304 SS sheath heaters (except HHS00003 with Inconel® 600) with 24" plain leads, and a type J thermocouple junction grounded at the tip of the cable, except those marked with a ⚡ (0.062" cable).

Longer lead length as well as optional stainless steel wire braid (B), fiberglass sleeve (S), stainless steel armored cable (A), or galvanized armored cable (C) protection is available upon request. See ordering code worksheet below for lead wire protection and lead length desired.

NOTE: Complete termination descriptions are on page 5-5.

Cable Diameter	Sheath Length		Watts	Watt Density		Volts	Part Number
	in	mm		W/in ²	W/cm ²		
⚡ .062" (1.57 mm)	34	863.6	400	60	9.30	120	HHS00001
	42	1066.8	400	49	7.59	120	HHS00002
	60	1524.0	200	19	2.94	120	HHS00003
	88	2235.2	450	26	4.03	120	HHS00004
.115" (2.92 mm)	49	1244.6	425	24	3.72	120	MHS00002
	73	1854.2	450	17	2.63	120	MHS00003
	87	2209.8	750	24	3.72	240	MHS00004
.125" (3.18 mm)	30	762.0	300	30	4.65	120	MHS00005
	35	889.0	330	24	3.72	240	MHS00006
	41	1041.4	365	23	3.56	120	MHS00007
	52	1320.8	400	20	3.10	240	MHS00008
	62	1574.8	780	32	4.96	240	MHS00009
	68	1727.2	300	11	1.70	120	MHS00010
	68	1727.2	300	11	1.70	240	MHS00011
	84	2133.6	780	24	3.72	120	MHS00012
	90	2286.0	660	19	2.94	120	MHS00013
.153" (3.89 mm)	17	431.8	200	24	3.72	240	MHS00014
	17	431.8	375	46	7.13	240	MHS00015
	18	457.2	250	29	4.49	240	MHS00016
	20	508.0	125	13	2.01	230	MHS00017
	20	508.0	250	26	4.03	230	MHS00018
	22	558.8	250	24	3.72	240	MHS00019
	25	635.0	380	32	4.96	240	MHS00020
	34	863.6	480	29	4.49	240	MHS00021
	40	1016.0	550	29	4.49	240	MHS00022
.174" (4.42 mm)	51	1295.4	650	27	4.18	240	MHS00023
	88	2235.2	1800	37	5.73	220	MHS00024
	93	2362.2	1700	33	5.11	220	MHS00025
	109	2768.6	1500	25	3.87	220	MHS00026
	166	4216.4	3350	37	5.73	220	MHS00027
	220	5588.0	2850	24	3.72	220	MHS00028
	77	1955.8	1700	34	5.27	220	MHS00029 [Ⓛ]
	90	2286.0	2000	37	5.73	220	MHS00030
.188" (4.78 mm)	105	2667.0	1800	29	4.49	220	MHS00031
	180	4572.0	3900	37	5.73	220	MHS00032
	191	4851.4	1000	9	1.39	220	MHS00033
	198	5029.2	3600	31	4.80	220	MHS00034
	146	3708.4	2850	31	4.80	380	MHS00035
.203" (5.16 mm)	182	4622.8	3900	34	5.27	480	MHS00036
	200	5080.0	4300	34	5.27	220	MHS00037
	223	5664.2	4000	28	4.34	220	MHS00038
	107	2717.8	2500	32	4.96	220	MHS00039
.220" (5.59 mm)	123	3124.2	2100	31	4.80	220	MHS00040
	205	5207.0	4800	34	5.27	220	MHS00041
	217	5511.8	3800	25	3.87	220	MHS00042
	109	2768.6	2700	34	5.27	220	MHS00043
.232" (5.89 mm)	119	3022.6	2550	29	4.49	220	MHS00044
	204	5181.6	4500	30	4.65	480	MHS00045
	211	5359.4	5000	32	4.96	220	MHS00046
	222	5638.8	4800	30	4.65	220	MHS00047
	89	2260.6	2600	37	5.73	220	MHS00048
	100	2540.0	2200	38	5.89	220	MHS00049
	103	2616.2	2750	34	5.27	220	MHS00050
.250" (6.35 mm)	105	2667.0	2100	25	3.87	220	MHS00051
	115	2921.0	2450	27	4.18	220	MHS00052
	118	2997.2	2600	28	4.34	220	MHS00053
	123	3124.2	2700	28	4.34	220	MHS00054
	130	3302.0	2600	25	3.87	220	MHS00055
	138	3505.2	2300	21	3.25	220	MHS00056
	205	5207.0	4200	30	4.65	220	MHS00057
	215	5461.0	4000	28	4.34	220	MHS00058
	240	6096.0	5500	26	4.03	220	MHS00059
	281	7137.4	4700	19	2.94	220	MHS00060

Type A__ – Stainless Steel Armor Cable

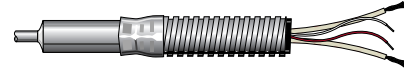

Type B__ – Stainless Steel Overbraid



Type C__ – Galvanized Armor Cable

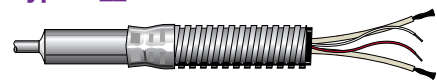

Type S__ – Fiberglass Sleeve



Type M__ – Plain Leads

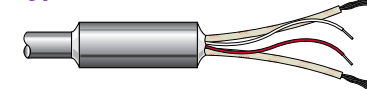

Potting Adapter Size without Crimping

5/16" O.D. × 1-1/2" long for 0.062" to 0.163" dia. cable
1/2" O.D. × 1-1/2" long for 0.174" to 0.250" dia. cable

Ordering Information

Standard Straight Tempco-Pak heaters are offered with plain lead wires. Use the part numbers at the left for 24" plain lead wires. If you need other than standard 24" leads and/or wire protection use the following ordering codes and a part number will be assigned.

Ordering Code:



Lead Length BOX 1

Whole inches 000 to 999

Termination Type BOX 2

- A = Stn. Stl. Cable
- B = Stn. Stl. Wire Braid
- C = Galvanized Cable
- S = Fiberglass Sleeve
- M = Plain Leads (Do not fill Box 3)

Length of Protection BOX 3

Whole inches 000 to 999

NOTE: Ⓛ Maximum Operating Temperature 500°C.



WARNING: Cancer and Reproductive Harm - www.P65Warnings.ca.gov.

(800) 323-6859 • Email: sales@tempco.com

Standard (Non-Stock) Square Straight Tempco-Pak Cable Heaters

Part Numbers are for heaters with 48" plain leads.

Longer lead length as well as optional stainless steel wire braid (B), fiberglass sleeve (S), stainless steel armored cable (A) or galvanized armored cable (C) protection is available upon request. See ordering code worksheet below for lead wire protection and lead length desired.

Standard Tempco-Pak Heaters are made with 304 Stainless Steel Sheath.

Cable Cross Section	Sheath Length		Cold Length		Watts	Watt Density		Volts	"J" T/C Junction	Part Number
	in	mm	in	mm		W/in ²	W/cm ²			
.125" x .125" (Square)	14 $\frac{1}{8}$	359	2	51	250	41.2	6.39	240	UG-T	MHS00128
	18 $\frac{1}{4}$	464	1 $\frac{3}{4}$	44	250	30.3	4.70	240	UG-T	MHS00129
	22 $\frac{1}{8}$	581	2 $\frac{1}{8}$	54	250	24.0	3.72	240	GRD	MHS00121
	23 $\frac{1}{4}$	591	1 $\frac{1}{2}$	38	450	41.3	6.40	240	UG-M	MHS00122
	26	660	4	101	300	27.2	4.22	240	GRD	MHS00123
	29	737	1 $\frac{1}{2}$	38	450	32.7	5.06	240	UG-N	MHS00124
	36 $\frac{1}{8}$	936	2	51	300	17.2	2.66	240	GRD	MHS00125
	41 $\frac{1}{8}$	1045	1 $\frac{7}{8}$	47	300	15.2	2.35	240	UG-M	MHS00126
	43 $\frac{3}{8}$	1108	1 $\frac{7}{8}$	47	300	14.3	2.21	240	UG-M	MHS00127
	20	508	2 $\frac{1}{2}$	64	315	36.0	5.58	240	N/A	HHS00167
	31 $\frac{1}{2}$	800	2 $\frac{1}{2}$	64	315	21.7	3.36	240	N/A	HHS00168
	31 $\frac{3}{4}$	806	2 $\frac{1}{2}$	64	600	41.0	6.36	240	N/A	HHS00169

(UG-M) — Ungrounded T/C junction is at the middle of the hot section

(UG-T) — Ungrounded T/C junction is at the tip

(UG-N) — Ungrounded T/C junction is 7" from the tip

Lead Wire Abrasion Protection Terminations

Type A — Stainless Steel Armor Cable



Type C — Galvanized Armor Cable

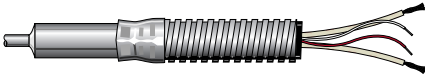

Type M — Plain Leads

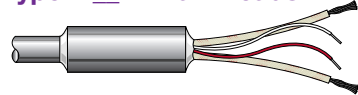

Type B — Stainless Steel Overbraid



Type S — Fiberglass Sleeve



Potting Adapter Size without Crimping

5/16" O.D. x 1-1/2" long

NOTE: Complete termination descriptions are on page 5-5.

Ordering Code:



Ordering Information

Part Numbers above are for Square Rectangular Tempco-Pak heaters with 48" plain lead wires. If you need other than standard 48" leads and/or wire protection use the ordering codes at the right and a part number will be assigned.

Lead Length BOX 1
Whole inches 000 to 999

Termination Type BOX 2
A = Stn. Stl. Cable
B = Stn. Stl. Wire Braid
C = Galvanized Cable
S = Fiberglass Sleeve
M = Plain Leads (Do not fill Box 3)

Length of Protection BOX 3
Whole inches 000 to 999

WARNING: Cancer and Reproductive Harm - www.P65Warnings.ca.gov.

Standard (Non-Stock) Rectangular Straight Tempco-Pak Cable Heaters

Part Numbers are for heaters with 48" plain leads.

Longer lead length as well as optional stainless steel wire braid (B), fiberglass sleeve (S), stainless steel armored cable (A) or galvanized armored cable (C) protection is available upon request.
See ordering code worksheet below for lead wire protection and lead length desired.

Standard Tempco-Pak Heaters are made with 304 Stainless Steel Sheath.

Cable Cross Section	Sheath Length		Cold Length		Watts	Watt Density		Volts	"J" T/C Junction	Part Number
	in	mm	in	mm		W/in ²	W/cm ²			
.110" x .160" (Rectangular)	21 $\frac{1}{8}$	537	1 $\frac{3}{8}$	41	300	28.5	4.41	240	UG-M	MHS00107
	27 $\frac{1}{2}$	698	1 $\frac{3}{8}$	41	350	25.0	3.87	240	UG-M	MHS00108
	30 $\frac{3}{4}$	781	1 $\frac{3}{8}$	48	400	25.6	3.97	240	UG-M	MHS00109
	32 $\frac{1}{4}$	819	1 $\frac{3}{8}$	41	400	24.2	3.74	240	UG-M	MHS00110
	35 $\frac{1}{4}$	895	1 $\frac{3}{4}$	44	450	24.8	3.86	240	UG-M	MHS00111
	35 $\frac{3}{8}$	911	1 $\frac{3}{8}$	41	425	23.0	3.56	240	UG-M	MHS00112
	40 $\frac{1}{4}$	1022	1 $\frac{1}{4}$	32	550	26.0	4.03	240	UG-M	MHS00113
	44 $\frac{1}{4}$	1124	1 $\frac{3}{8}$	41	500	21.7	3.36	240	UG-M	MHS00114
	44 $\frac{3}{4}$	1137	1 $\frac{1}{4}$	32	700	29.8	4.62	240	UG-M	MHS00115
	53 $\frac{1}{2}$	1359	1 $\frac{3}{8}$	41	800	28.8	4.46	240	UG-M	MHS00116
	57	1448	1 $\frac{3}{8}$	41	500	16.7	2.58	240	UG-M	MHS00117
	57 $\frac{3}{8}$	1464	1 $\frac{3}{8}$	41	550	18.1	2.81	240	UG-M	MHS00118
	62 $\frac{3}{4}$	1594	1 $\frac{3}{8}$	41	900	27.2	4.22	240	UG-M	MHS00119
	72	1829	1 $\frac{3}{8}$	41	1000	26.3	4.07	240	UG-M	MHS00120
	13 $\frac{3}{4}$	349	1 $\frac{3}{8}$	48	225	35.0	5.42	240	No T/C	HHS00159
	20 $\frac{1}{2}$	521	1 $\frac{3}{8}$	41	250	24.5	3.79	240	No T/C	HHS00160
	24 $\frac{3}{8}$	619	1 $\frac{3}{8}$	41	300	24.4	3.78	240	No T/C	HHS00161
	32 $\frac{3}{8}$	822	1 $\frac{3}{8}$	41	350	21.0	3.25	240	No T/C	HHS00162
	40 $\frac{1}{4}$	1022	1 $\frac{3}{8}$	41	400	19.1	2.96	240	No T/C	HHS00163
	48 $\frac{1}{4}$	1226	1 $\frac{3}{8}$	41	425	16.8	2.60	240	No T/C	HHS00164
53 $\frac{1}{2}$	1359	1 $\frac{3}{8}$	41	800	28.5	4.41	240	No T/C	HHS00165	
64 $\frac{1}{8}$	1629	1 $\frac{3}{8}$	41	500	14.8	2.29	240	No T/C	HHS00166	

UG-M: — Ungrounded T/C junction is 8" to 11" from the tip

Lead Wire Abrasion Protection Terminations

Type A__ — Stainless Steel Armor Cable

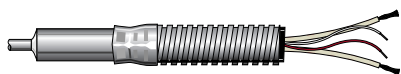

Type C__ — Galvanized Armor Cable



Type M__ — Plain Leads

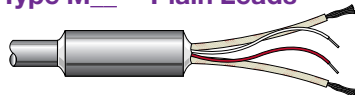

Type B__ — Stainless Steel Overbraid



Type S__ — Fiberglass Sleeve



Potting Adapter Size without Crimping

5/16" O.D. x 1-1/2" long

Ordering Code:



NOTE: Complete termination descriptions are on page 5-5.

Ordering Information

Part Numbers above are for Standard Rectangular Tempco-Pak heaters with 48" plain lead wires. If you need other than standard 48" leads and/or wire protection use the ordering codes at the right and a part number will be assigned.

Lead Length BOX 1

Whole inches 000 to 999

Termination Type BOX 2

A = Stn. Stl. Cable
B = Stn. Stl. Wire Braid
C = Galvanized Cable
S = Fiberglass Sleeve
M = Plain Leads (Do not fill Box 3)

Length of Protection BOX 3

Whole inches 000 to 999

⚠ WARNING: Cancer and Reproductive Harm - www.P65Warnings.ca.gov.

Bulk Round Heater Cable



Typical Applications

- *Blown Film Die Heaters*
- *Heat Tracing*
- *De-icing Car Wash Door Rails*
- *De-icing Outside Stairways*

Design and Construction Specifications

Terminations

See page 5-5 for potted lead transitions. There are two choices of potting compounds. Either cement potting for a high temperature application or high temperature epoxy for 450°F (232°C) maximum temperature. Also, there are three major choices of lead wires:

- M1** — TGGT (Teflon® tape, fiberglass, Teflon® treated fiberglass overbraid) insulated lead wire for 482°F (250°C).
- M2** — Teflon® insulated lead wire, which is normally potted with a high temperature epoxy rated 450°F (232°C)
- M3** — MGT (mica tape, Teflon® treated fiberglass overbraid) insulated lead wire for 842°F (450°C).

Minimum Bending Radius

Minimum bending radius for all mineral insulated cable heaters is two times the sheath diameter.

Power Calculation

The required wattage can be calculated using the following formula:

$$\text{Wattage} = \frac{(\text{Voltage})^2}{\text{Cable length (in feet)} \times \text{Ohms/foot (from table)}}$$

Standard Single Conductor Heater Cable

Sheath OD		Resistance (+/-10%)		Maximum Length		Sheath Material	Maximum Current Allowed (Amps)	Part Number
in	mm	ohms/ft.	ohms/mtr.	feet	meters			
.125	3.17	0.67	2.2	250	75	Inconel® 600	13.3	CAS01125
.125	3.17	0.72	2.4	250	75	Inconel® 600	12.5	CAS02125
.125	3.17	0.78	2.6	250	75	Inconel® 600	12.0	CAS03125

Standard Double Conductor (Duplex) Heater Cable

Sheath OD		Resistance (+/-10%)		Maximum Length		Sheath Material	Maximum Current Allowed (Amps)	Part Number
in	mm	ohms/ft.	ohms/mtr.	feet	meters			
.040	1.00	37.0	122.0	500	152	Inconel® 600	1.5	CAW00040
.055	1.39	16.4	54.1	500	152	Inconel® 600	2.3	CAW00055
.062	1.59	13.7	45.2	400	121	Inconel® 600	2.9	CAW00062
.062	1.59	13.2	43.6	400	121	304 SS	3.0	CAW01062
.062	1.59	8.1	26.7	400	121	304 SS	4.0	CAW02062
.062	1.59	7.9	26.1	400	121	304 SS	4.1	CAW03062
.062	1.59	4.6	15.1	400	121	304 SS	5.8	CAW05062
.064	1.62	6.5	21.4	400	121	304 SS	4.7	CAW04064
.125	3.18	7.0	23.1	250	75	304 SS	4.7	CAC53125
.125	3.18	3.4	11.2	250	75	Inconel® 600	7.3	CAW00125
.147	3.73	4.8	15.8	200	60	304 SS	5.9	CAC53147
.147	3.73	2.5	8.2	200	60	Inconel® 600	9.0	CAW00147
.153	3.88	4.5	14.8	150	45	304 SS	6.0	CAC53153
.153	3.88	2.3	7.6	150	45	Inconel® 600	9.2	CAW00153
.153	3.88	1.9	6.3	150	45	304 SS	9.7	CAW01153
.153	3.88	1.6	5.3	150	45	304 SS	11.5	CAW02153
.153	3.88	1.4	4.6	150	45	304 SS	13.0	CAW03153
.163	4.14	4.0	13.2	130	39	304 SS	6.5	CAC53163
.163	4.14	2.1	6.9	130	39	Inconel® 600	9.6	CAW00163
.163	4.14	1.7	5.6	130	39	304 SS	10.5	CAW01163
.163	4.14	1.5	4.9	130	39	304 SS	12.5	CAW02163
.163	4.14	1.2	3.9	130	39	304 SS	14.0	CAW03163
.188	4.77	3.0	9.9	100	30	304 SS	7.0	CAC53188
.188	4.77	1.5	5.0	100	30	Inconel® 600	12.0	CAW00188
.188	4.77	1.3	4.3	100	30	304 SS	13.3	CAW01188
.188	4.77	1.06	3.5	100	30	304 SS	15.5	CAW02188
.188	4.77	0.86	2.8	100	30	304 SS	17.0	CAW03188
.210	5.33	1.18	3.9	80	24	Inconel® 600	15.4	CAW00210
.210	5.33	1.17	3.8	80	24	304 SS	15.5	CAW01210
.210	5.33	0.84	2.7	80	24	304 SS	18.3	CAW02210
.210	5.33	0.75	2.5	80	24	304 SS	20.0	CAW03210
.220	5.59	2.17	7.1	75	22	304 SS	9.5	CAC53220
.220	5.59	0.98	3.2	75	22	304 SS	16.5	CAW01220
.220	5.59	0.76	2.5	75	22	304 SS	19.5	CAW02220
.250	6.35	1.8	5.9	58	17	304 SS	11.3	CAC53250
.250	6.35	0.9	2.9	58	17	Inconel® 600	18.3	CAW00250
.250	6.35	0.87	2.9	58	17	304 SS	20.0	CAW01250
.250	6.35	0.59	1.9	58	17	304 SS	23.0	CAW02250
.250	6.35	0.48	1.6	58	17	304 SS	25.0	CAW03250



Note: Maximum lengths shown are manufactured lengths. Cable is shipped in random lengths unless specific lengths are ordered.

Tempco Replacement Mini-Coil Heaters (Round Cable) for OEM Hot Runner Systems

Tempco's Mini-Coil Band Heaters are designed and manufactured under the tightest tolerances so that they may be used in hot runner/runnerless injection mold tooling with complete confidence on maintaining the manufacturer's original balanced heating when using a minimum of thermocouples and temperature control zones.

- $\pm 2\%$ Resistance Tolerance
- 5" and 7" Staggered Cold Lead Length
- 72" Insulated Lead Wire Length
White/Black for 250W and White/Red for 125W

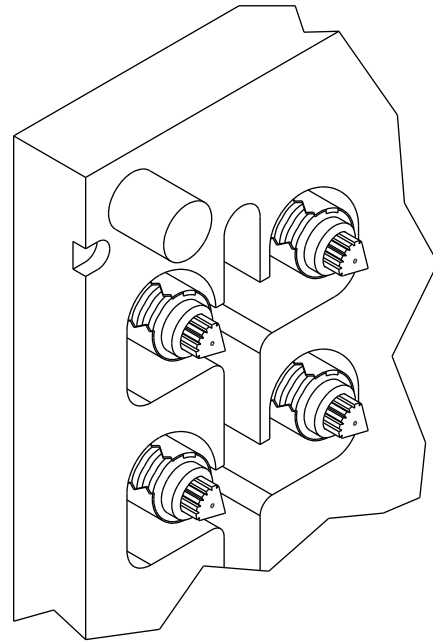

Cam Operated Clamping

Clamp Screw Clamping

Clamp Screw

Clamping

Screw operated clamping for the traditional style.

Cam Operated Clamping

Cam operated axial clamping allows tool room personnel to replace the heating element or the thermocouple of the gate bushing without having to remove the bushing from the mold. This can even be done in emergencies while the mold is still in the press, saving hours of downtime. The hex head cam is accessed from the front, parallel to the bushing's shaft.

Specifications

Mechanical

- Coil Heater Diameter:** 0.055", ± 0.002 "
- Thermocouple:** Type J, 0.055" dia., ± 0.002 "
- Inner Diameter:** ± 0.002 "
- Width/Length:** ± 0.020 "
- Axial Clamp Hex:** Tempered 416 series SS
Hex size: 1/8"
Rotation: 150 degrees
- Clamp Screw:** (2) 6-32 \times 1/2", SS,
Hex size 7/64"
- Heater Leads:** 18 ga. silver coated copper, Teflon[®]
insulation, 200°C/392°F
Staggered 5" and 7"
- Thermocouple Leads:** Fiberglass insulation, 1000°F

Electrical

- Resistance Tolerance:** $\pm 2\%$
- Wattage Tolerance:** $\pm 2\%$
- Voltage:** Standard voltages are 120 and 240VAC;
other voltages can be designed.
Consult Tempco with your requirements.

Tempco Replacement Mini-Coil Heaters (Round Cable) for OEM Hot Runner Systems

Stock and Standard (Non-Stock) Cam Operated Clamping Round Cable with Thermocouple

Stock Items Are Shown In **RED**



Clamp Style	ID		Length		Watts	Volts	Part Number Heater Only	Part Number With Type J T/C
	in	mm	in	mm				
Axial	.750	19.0	1.20	30.5	① 149	240	HRN00100	HRY00110
	.750	19.0	1.20	30.5	② 268	240	HRN00101	HRY00111
	.750	19.0	1.75	44.4	268	240	HRN00102	HRY00112
	.750	19.0	2.00	50.8	323	240	HRN00103	HRY00113
	.875	22.2	1.75	44.4	268	240	HRN00104	HRY00114
	1.000	25.4	1.20	30.5	300	240	HRN00105	HRY00115
	1.000	25.4	2.00	25.4	318	240	HRN00106	HRY00116
	1.000	25.4	1.20	30.5	350	240	HRN00107	HRY00117
	1.000	25.4	2.00	50.8	440	240	HRN00108	HRY00118
	.500	12.7	1.20	31.7	120	240	HRN00109	HRY00119

Stock and Standard (Non-Stock) Screw Operated Clamping Round Cable with Thermocouple

Stock Items Are Shown In **RED**

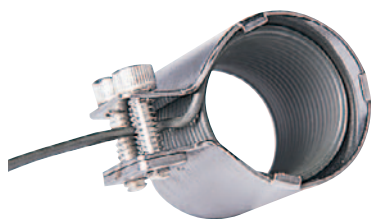

Clamp Style	ID		Length		Watts	Volts	Part Number Heater Only	Part Number With Type J T/C
	in	mm	in	mm				
Screw	.750	19.0	1.20	30.5	① 149	240	HRN01100	HRY01113
	.750	19.0	1.20	30.5	② 268	240	HRN01101	HRY01114
	.750	19.0	2.50	63.5	323	240	HRN01102	HRY01115
	.875	22.2	1.20	30.5	② 268	240	HRN01103	HRY01116
	.875	22.2	2.00	50.8	300	240	HRN01104	HRY01117
	.875	22.2	1.75	44.4	350	240	HRN01105	HRY01118
	.750	19.0	1.20	30.5	400	240	HRN01106	HRY01119
	.750	19.0	2.00	50.8	272	240	HRN01107	HRY01120
	.750	19.0	2.00	50.8	400	240	HRN01108	HRY01121
	.750	19.0	1.20	30.5	186	240	HRN01109	HRY01122
	1.500	38.1	2.50	63.5	675	240	HRN01110	HRY01123
	1.750	44.4	1.75	44.4	450	240	HRN01111	HRY01124
	2.500	63.5	1.50	38.1	380	240	HRN01112	HRY01125



Notes: ① It is the hot runner industry practice to refer to this heater as 125W even though the actual wattage will be dependent on the applied voltage. The resistance is 386.58 ohms.



Notes: ② It is the hot runner industry practice to refer to this heater as 250W even though the actual wattage will be dependent on the applied voltage. The resistance is 214.98 ohms.

Industry Cross Reference Part Numbers

Tempco Part Number	OEM Part Number	Rosemount Part Number
HRN00100	534234	904FE101
HRN01100	520156	904EJ101, 904EN101, 904FB101

Tempco Part Number	OEM Part Number	Rosemount Part Number
HRN00101	534233	904FE131
HRN01101	521334	904EJ131, 904EN131, 904FB131
HRN01103		904EJ141, 904EN141, 904FB141

Ordering Information

Stock Heaters

Select a Mini-Coil Heater from the standard sizes and ratings list.

Custom Engineered/Manufactured Heaters

An electric heater can be very application specific; for sizes, ratings and terminations not listed, **TEMPCO** will design and manufacture a Mini-Coil heater to meet your requirements. **Standard lead time is 3 weeks.**

Please Specify the following:

- Inner Diameter
- Width/Length
- Wattage
- Voltage
- Termination Type
- Cable/Braid Length
- Clamp Style
- Special Features

WARNING: Cancer and Reproductive Harm - www.P65Warnings.ca.gov.

Coil & Cable Heaters



Cast Nozzle Heater Bushings

Cast Bronze Nozzle Heater Bushings

Typical Applications

- ➔ Hot Runner Systems
- ➔ Sprue Bushings
- ➔ Hot Melt Adhesive Systems



Typical Applications

- ➔ Plastic Injection Nozzles
- ➔ Medical, Laboratory and Pharmaceutical Equipment

Design Features

- * Bronze Cast construction for excellent heat transfer and long life
- * Operating Temperature to 1200°F (650°C)
- * Built-in Type J or K Thermocouple for accurate temperature control
- * Distributed wattage for even heat transfer
- * Precision machining of the inside diameter
- * Choice of leads and lead protection

Custom Engineered/Manufactured to meet customer specifications – we welcome your inquiries.

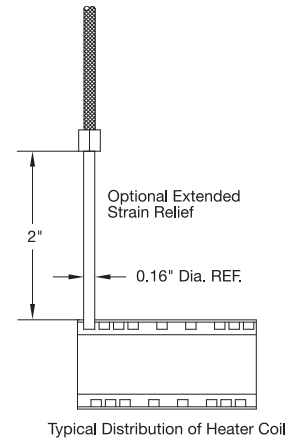
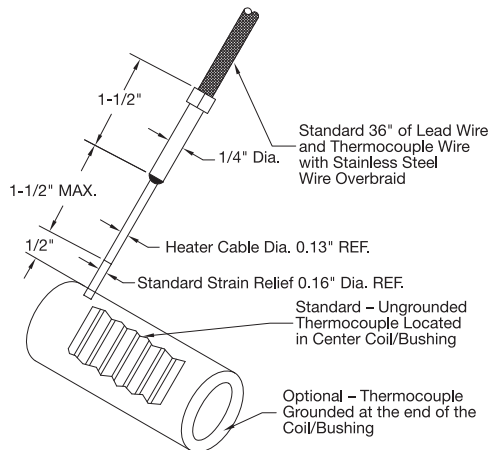

Construction Characteristics

Tempco's cast bronze nozzle heater bushings offer the latest in state-of-the-art technology to these innovative designs. They eliminate uneven temperature profiles and short heater life; their precision machining also eliminates poor fit and the need for clamping bands, while providing maximum heat transfer.

The casting is protected by a stainless steel tube. The maximum operating temperature for the bronze casting is 1200°F (650°C); the optional aluminum casting has a maximum operating temperature of 600°F (315°C). The built-in thermocouple in either Type J or

K gives exceptional temperature control when connected to a Tempco **TCC** controller. The thermocouple has as standard an ungrounded junction located in the center of the width, which helps eliminate stray EMFs caused by the heater. A grounded junction at the end is optional.

The heater and thermocouple have a standard termination of 36-inch fiberglass leads with a stainless steel overbraid. Options include Teflon® insulated leads and armor cable. All terminations are available with the optional 2-inch-long extended strain relief.

Standard (Non-Stock) Bronze Heater Bushings

ID		OD		Width		Volts	Watts	Part Number
in	mm	in	mm	in	mm			
1/2	13	1	25	2	51	240	300	NHB00002
5/8	16	1 1/8	29	2	51	240	300	NHB00003
5/8	16	1 1/8	29	3	76	240	500	NHB00004
5/8	16	1 1/8	29	4	102	240	750	NHB00005
3/4	19	1 1/4	32	1	25	240	250	NHB00006
3/4	19	1 1/4	32	2	51	240	350	NHB00007
7/8	22	1 3/8	35	2	51	240	500	NHB00008
7/8	22	1 3/8	35	3	76	240	750	NHB00009
7/8	22	1 3/8	35	4	102	240	1000	NHB00010



Note: Inside Diameter machined to a tolerance of $\pm 0.001"$. Width tolerance to $4" \pm 0.02"$. Wattage and Resistance are $\pm 10\%$.

Tabletop Point-of-Use Temperature Control Console Systems

See Section 13, Page 13-52



Custom Engineered/Manufactured Heater Bushings

Ordering Code:

NHB -

Inside Diameter BOX 1

- A = .375"
- B = .500"
- C = .563"
- D = .625"
- E = .750"
- F = .875"
- G = Other (Specify)

Nominal Outside Diameter BOX 2

- A = 1"
- B = 1-1/8"
- C = 1-1/4"
- D = 1-3/8"
- E = Other (Specify)

Width (Length) BOX 3

- A = 1"
- B = 2"
- C = 3"
- D = 4"
- X = Other (Specify)

Volts BOX 4

- A = 240 Standard
- B = 120 Optional

Wattage BOX 5

- X = (Specify)

Lead Length BOX 6

- Whole inches
- 01 to 999
- 36" Standard (036)

Lead Construction BOX 7

- A = Fiberglass, Heater and T/C with SS overbraid – Standard
 - B = Fiberglass, Heater and T/C
 - C = Teflon® Insulated, Heater and T/C
 - D = Teflon® Insulated with SS overbraid (no T/C)
 - E = Fiberglass Insulated with SS armor cable (no T/C)
 - F = Teflon® Insulated with SS armor cable (no T/C)
- NOTE: For A, D, E and F the cable or braid length will be 2" shorter than the lead wire length unless otherwise specified.

Extended Strain Relief (2" long) BOX 8

- 1 = Yes
- 2 = No

Thermocouple Type BOX 9

- J = Type J Iron/Constantan
- K = Type K Chromel/Alumel
- 0 = None Required

T/C Junction Location BOX 10

- A = Ungrounded (Standard)
- B = Grounded (Optional)
- 0 = None Required

Casting Construction BOX 11

- B = Bronze (Standard) 1200°F (650°C)
- A = Aluminum (Optional) 600°F (315°C)

Cold Length BOX 12

- Whole inches
- 02 to 18
- 2" Standard (02)

Special Requirements BOX 13

- X = Specify
 - 0 = None
- Example:** Set screws in bushing available upon request.

Ordering Information

Standard (Non-Stock) Heaters

Order standard Heater Bushings by part number from the table on page 5-28.

Custom Engineered/Manufactured Heaters

An electric heater can be very application specific; for sizes, ratings and terminations not listed, **TEMPCO** will design and manufacture a Heater Bushing to meet your requirements. **Standard lead time is 4 weeks.**

To order a custom Heater Bushing **create an order code number** by filling in the boxes with the appropriate number and/or letter designation for your requirements. A product part number will be assigned at time of order.

⚠ WARNING: Cancer and Reproductive Harm - www.P65Warnings.ca.gov.

Gamma Series Dual Sleeve Mini-Coil Heater



Design Features

- * ID Tolerance: $\pm .0005$ "
- * Wall Thickness: 0.130"
- * Lead Wires: 72" long Teflon[®] insulated
- * Cold leads: 5" and 7" standard
- * Resistance Tolerance: $\pm 2\%$
- * Watt Density: Over 100 w/sq.in. possible

Gamma Series mini-coil heaters for hot runner tooling are constructed with the heating element tightly sandwiched between a nickel plated copper inner sleeve and a stainless steel outer sleeve. The differences in heat transfer characteristics of the sleeves direct the heat generated by the coil inward, toward the nozzle, increasing overall efficiency. The inner diameter of the assembly is very tightly controlled, allowing for a slip fit with no clamping required.

NOTE: Caps Sold Separately

Stock and Standard (Non-Stock) Sizes and Ratings

Stock Items Are Shown In RED



For replacement threaded caps order Part Number HRN94999 (19.05 mm, 0.75" dia.).

ID	Length		Watts	Volts	OEM Part Number	Tempco Part Number
	mm	in				
19.05 mm (3/4")	30	1.181	220	240	534975	HRN40001
	40	1.575	220	240	534976	HRN40002
	50	1.969	220	240	534977	HRN40003
	60	2.362	220	240	534978	HRN40004
	70	2.756	220	240	534979	HRN40005
	80	3.150	220	240	534980	HRN40006
	90	3.543	220	240	534981	HRN40007
	100	3.937	220	240	534982	HRN40008
	110	4.331	220	240	534983	HRN40009
	30	1.181	350	240	—	HRN40010
	40	1.575	350	240	—	HRN40011
	50	1.969	350	240	—	HRN40012
	60	2.362	400	240	—	HRN40013
	70	2.756	400	240	—	HRN40014
	80	3.150	400	240	—	HRN40015
	90	3.543	400	240	—	HRN40016
	100	3.937	450	240	—	HRN40017
	110	4.331	400	240	—	HRN40018

Ordering Information

Stock Heaters

Select a Mini-Coil Heater from the standard sizes and ratings list.

Custom Engineered/Manufactured Heaters

An electric heater can be very application specific; for sizes, ratings and terminations not listed, **TEMPCO** will design and manufacture a Mini-Coil heater to meet your requirements. **Standard lead time is 3 weeks.**

Please Specify the following:

- Inner Diameter
- Width/Length
- Wattage
- Voltage
- Termination Type
- Cable/Braid Length
- Clamp Style
- Special Features

⚠ WARNING: Cancer and Reproductive Harm - www.P65Warnings.ca.gov.



Table Of Contents

Pictorial Index	A-14	Constant Wattage Heating Cable	6-8
Introduction to Heat Trace Cable Systems	6-2	Self-Limiting Heating Cable.....	6-11
Installation Examples	6-3	Temperature Controls and Accessories	6-13
Engineering Guide	6-4	Thermal Insulation	6-14
Heat Loss Tables	6-5		

6

section

Heat Trace Cable

Introduction

Introduction to Heat Trace Cable Systems



Tempco's Heat Trace Cables are used to counteract the effects of heat dissipation from process pipe and equipment through its insulation (if any). This heat loss allows a drop in temperature, bringing about unacceptable consequences such as frozen pipes, reduced fluid viscosity, etc.

The use of heat trace cable replaces the heat lost, maintaining the desired temperature through the application of the required wattage.

There are two general categories of Electrical Heat Trace Cable:

Constant Wattage and
Self-Limiting, or Self-Regulating cable

Each style of heat trace cable serves different applications.

The Most Commonly Asked Questions About Heat Trace Cables

Which cable do I need?

Selecting the proper cable depends on many different variables. The pipe size, exposure temperatures, ambient conditions, insulation type and thickness, maintenance temperatures, heat-up rate, flow rate, and type of material involved all play a part in determining which cable is best for your application.

Consult pages 6-2 through 6-14 and/or contact **Tempco** to assist you in making the correct choice.

What are the requirements for metal overbraid and outer jackets?

Metal overbraid is required on all heat trace cabling to meet NEC code for grounding. The braid provides mechanical protection, as well as a low-resistance grounding path.

On SL self-limiting cable, in addition to the standard metal overbraid, an optional thermoplastic elastomer or fluoropolymer outer jacket is recommended when exposure to organic chemicals or corrosives is expected.

Can the cable be cut in the field without changing the resistance?

Tempco's Constant Wattage and Self-Limiting style cable is designed to be a certain wattage per foot within a certain circuit length. All Constant Wattage cables have modules cut out of the bus wire jacket, exposing the bare wire at alternating points at pre-determined lengths. The cable is designed to be a certain wattage within this circuit length. These circuits run the length of the spool, similar to short runs of cable run in series to make one long cable. If a circuit is interrupted (cut), the cable will be unheated up until the next complete circuit.



Types of Heat Trace Cable



Constant Wattage Cable This style of heat trace cable is designed to put out a certain amount of wattage per linear foot at a particular voltage. It is always putting out the designed watts per foot, no matter what the surface or ambient temperature is. This means that in most situations the heating cable is continually pumping heat into the vessel or pipe being maintained or heated. If the heat trace cable is

not attached to some kind of control device, it has the potential to overheat itself and burn out. This would not only ruin the cable, but could cause damage to whatever it is being used on. Therefore, constant wattage cable must be controlled by some means.

Self-Limiting, or Self-Regulating Cable This cable will self-adjust its power output in relation to the surface temperature as well as ambient conditions. In other words, the hotter the conditions get, the lower the wattage output becomes. This characteristic allows this type of cable to be used without a control device. However, if a particular temperature is required, then a control device must be used.



Note: Both cables are used by all types of industry. It is the user's requirements that dictate which design to use. Higher temperature maintenance applications will use the constant wattage cables due to the higher maximum exposure temperatures that they allow. Lower temperature maintenance applications, such as freeze protection, can use the self-limiting cable, although constant wattage cable can be used just as effectively as long as it is controlled properly.

Heat Trace Cable Application/Installation Examples

<p>Installation of Heating Cable on a Pressure Sense Line</p>	<p>Pipe Instrument Tube Heating Cable Instrument Body</p>	<p>Installation of Heating Cable on a Pressure Indicator</p>
<p>Installation of Heating Cable System in Non-Hazardous Area</p>	<p>Supply Power Wiring Temperature Controller Fiberglass Tape Heating Cable Pipe Standoff Metal Pipe Straps</p>	<p>Installation of Heating Cable on a Straight Pipe Run</p>
<p>Installation of Temperature Sensor</p>	<p>Fiberglass Tape Pipe Heating Cable Temperature Sensor</p>	<p>Installation of Heating Cable at a Blind Tee</p>
<p>Installation of Heating Cable at a Pipe Support</p>	<p>Heating Cable Pipe Pipe Support (or Hanger)</p>	<p>Installation of Heating Cable at a Flange Body</p>
<p>Typical Installation of Heating Cable for Supports</p>	<p>Hanger Extension Stem Length of Cable Dependent on Mass and Size of Support</p>	<p>Installation of Heater on Diaphragm Valve (when surface area is sufficient)</p>

How to Determine Heat Trace Cable Requirements

Heat Loss

Heat loss is the amount of heat given up to the surrounding atmosphere through a combination of conduction, convection, and radiation. The parameters required to determine total heat losses on an application may include several of the following:

- * Temperature to be maintained
- * Lowest expected ambient temperature
- * Type, size, and run-length of pipe or tubing
- * Type and thickness of thermal insulation to be used
- * Losses through the vessel wall and the insulation
- * Flow rate

Calculating Heat Loss from Insulated Pipe

1. Calculate the ΔT , or temperature difference. Subtract the lowest ambient temperature from the operating temperature.
2. Using the ΔT calculated in step 1, and the insulation thickness, refer to **Tables 1-A through 1-E—Heat Loss for Pipes (pages 6-5 and 6-6)**, to determine the heat loss in watts per linear foot of pipe.
3. Depending on the type of insulation used in the application, multiply result from step 2 by the appropriate factor from **Table 2—Insulation Factor (page 6-6)**. The resulting number is the heat loss expressed in watts per linear foot of pipe to be made up by the heat tracer.

Determine the Correct Heat Trace Cable

Determine the cable most appropriate for your system based on the temperature to be maintained, environment, length of the run, and the voltages available. There are Tempco heating cables available for most heat tracing applications.

If the watts per foot rating of the cable selected is more than the heat loss per foot, then a straight run may be used.

If the watts per foot rating of the cable selected is less than the heat loss per foot, your options are:

- a. Use a higher wattage cable.
- b. Use multiple straight runs.
- c. Spiral wrap the cable on the pipe.
- d. Use insulation with a higher insulation factor or thickness.

Calculating Heat Loss for Valves and Supports

To determine the heat loss multiplication factor for valves, refer to **Table 4—Heat Loss Multiplication Factors for Valves (page 6-7)**. The heat loss factor is based on a typical gate valve with insulation coverage to include the body, flange, and bonnet of the valve.

To determine adjusted multiplication factors for other types of valves and supports, use the following conversion factors:

To determine adjusted multiplication factors for other types of valves and supports, use the following conversion factors:

Gate valve	1.0	Ball valve	0.7
Globe valve	0.95	Butterfly valve	0.60
Pipe supports	0.50		

Determine the Total Amount of Heat Trace Required

Add the length of cable required for each valve and support to the length of cable required for the total pipe within your system.

Sample Calculation

Engineering Example Specifications

Operating Temperature: 55°F

Minimum Ambient Temperature: -20°F

Pipe Size: 4" steel pipe

Pipe Length: 200 ft.

Valve: 1 Gate Valve

Insulation Thickness and Type: 1" of Calcium Silicate

Voltage: 120 or 240 volts

PROCEDURE

1. Determine the heat loss.

a. Difference between low ambient and operating temperature: $55^{\circ}\text{F} - (-20^{\circ}\text{F}) = \Delta T$
 $\Delta T = 75^{\circ}\text{F}$

b. Determine the heat loss by referring to **Table 1-A - Heat Loss for Pipes**. For $\Delta T = 75^{\circ}\text{F}$, a 4" diameter pipe with 1" thick insulation will have a Heat Loss Factor of 7.6 W/ft.

2. Determine the adjusted heat loss for calcium silicate insulation (heat loss chart is based on fiberglass) by referring to **Table 2 - Insulation Factor** (page 6-6). Adjustment = $7.6\text{ W} \times 1.47 = 11.17\text{ W/ft}$. Adjusted Heat Loss

3. Select correct heating cable (by voltage and wattage) required to replace a heat loss of 11.17 W/ft. Use one straight run of 12 W/ft. or three straight runs of 4 W/ft.

4. Determine the heat loss of the valve gate and supports.

Refer to **Table 4 - Heat Loss Multiplication Factors for Valves** (page 6-7). For a 4" diameter pipe, the heat loss multiplication factor is 2.92.

Valve heat loss factor = $11.17\text{ W/ft.} \times 2.92 = 32.62\text{ W}$

5. Determine the cable requirements for the valve.

Divide valve heat loss by W/ft. of selected cable. Length of cable required for valve:

$32.62\text{ W/ft.} \div 12\text{ W} = 2.72\text{ ft.}$

6. Determine total cable requirements.

a. Cable required for pipe:

1 run \times 200 ft. = 200 ft.

b. Cable required for valve = 2.72 ft.

c. Total: 200 ft. + 2.72 ft. = 203 ft.

Round this number (203) up to the nearest number evenly divisible by the module (module length = 4 ft.), i.e. 204 ft.

d. Add module length (4 ft.) for cold leads for termination:
204 ft. + 4 ft. = 208 ft.

Total feet of cable required = 208 ft. of 12 W/ft. heating cable.



Heat Loss Tables

Table 1-A Heat Loss for Pipes (Watts Per Foot) Insulation Thickness 1"

ΔT	NPS Pipe Size																		
	0.25	0.5	0.75	1	1.5	2	2.5	3	4	6	8	10	12	14	16	18	20	24	30
25	0.6	0.7	0.8	1.0	1.2	1.5	1.7	2.0	2.4	3.3	4.2	5.2	6.0	6.6	7.5	8.4	9.2	11.0	13.6
50	1.2	1.5	1.7	2.0	2.5	3.0	3.4	4.0	4.9	7.0	8.7	10.6	12.4	13.5	15.3	17.1	18.9	22.5	28.0
75	1.8	2.3	2.6	3.0	3.9	4.6	5.3	6.2	7.6	10.6	13.3	16.3	19.1	20.8	23.6	26.3	29.1	34.7	43.0
100	2.5	3.2	3.6	4.2	5.3	6.3	7.2	8.4	10.4	14.4	18.2	22.2	26.0	28.4	32.2	36.0	39.8	47.3	58.7
125	3.2	4.0	4.6	5.3	6.8	8.0	9.3	10.8	13.3	18.5	23.3	28.5	33.3	36.4	41.2	46.0	50.9	60.6	75.1
150	3.9	5.0	5.7	6.5	8.4	9.8	11.4	13.3	16.3	22.7	28.6	35.0	40.9	44.6	50.6	56.5	62.5	74.4	92.2
175	4.7	5.9	6.8	7.8	10.0	11.7	13.6	15.8	19.4	27.0	34.2	41.7	48.8	53.3	60.4	67.5	74.6	88.7	110.0
200	5.5	6.9	7.9	9.1	11.7	13.7	15.9	18.5	22.7	31.6	39.9	48.7	57.0	62.2	70.5	78.8	87.1	103.7	128.5
225	6.3	8.0	9.1	10.5	13.4	15.8	18.2	21.2	26.1	36.3	45.9	56.0	65.5	71.5	81.0	90.6	100.1	119.1	147.7
250	7.1	9.0	10.3	11.9	15.2	17.9	20.7	24.1	29.6	41.2	52.0	63.5	74.3	81.1	91.9	102.7	113.5	135.2	167.6
275	8.0	10.1	11.6	13.3	17.1	20.1	23.2	27.1	33.2	46.2	58.4	71.3	83.5	91.1	103.2	115.3	127.5	151.7	188.1
300	8.9	11.3	12.9	14.9	19.0	22.4	25.8	30.1	37.0	51.5	65.0	79.4	92.9	101.3	114.8	128.4	141.9	168.9	209.4
325	9.8	12.5	14.2	16.4	21.0	24.7	28.6	33.3	40.8	56.8	71.8	87.7	102.6	111.9	126.9	141.8	156.7	186.5	231.3
350	10.8	13.7	15.6	18.0	23.1	27.1	31.3	36.5	44.8	62.4	78.8	96.2	112.6	122.9	139.3	155.7	172.0	204.8	253.9
375	11.8	15.0	17.1	19.7	25.2	29.6	34.2	39.9	48.9	68.1	86.1	105.1	123.0	134.2	152.0	169.9	187.8	223.5	277.1
400	12.8	16.3	18.5	21.4	27.4	32.2	37.2	43.3	53.2	74.0	93.5	114.2	133.6	145.8	165.2	184.6	204.0	242.9	301.1

Table 1-B Heat Loss for Pipes (Watts Per Foot) Insulation Thickness 1.5"

ΔT	NPS Pipe Size																		
	0.25	0.5	0.75	1	1.5	2	2.5	3	4	6	8	10	12	14	16	18	20	24	30
25	0.5	0.6	0.7	0.8	0.9	1.1	1.3	1.4	1.7	2.4	3.0	3.6	4.2	4.6	5.2	5.8	6.4	7.5	9.3
50	1.0	1.2	1.4	1.6	1.9	2.2	2.6	3.0	3.6	4.9	6.1	7.4	8.6	9.4	10.6	11.8	13.0	15.5	19.1
75	1.5	1.9	2.1	2.4	3.0	3.5	3.9	4.5	5.5	7.5	9.4	11.4	13.3	14.1	16.3	18.2	20.0	23.8	29.4
100	2.1	2.5	2.9	3.3	4.1	4.7	5.4	6.2	7.5	10.3	12.8	15.5	18.1	19.7	22.2	24.8	27.3	32.4	40.1
125	2.6	3.3	3.7	4.2	5.2	6.0	6.9	7.9	9.6	13.1	16.4	19.9	23.2	25.2	28.5	31.7	35.0	41.5	51.3
150	3.2	4.0	4.5	5.1	6.4	7.4	8.5	9.7	11.8	16.1	20.1	24.4	28.4	30.9	34.9	38.9	42.9	50.9	62.9
175	3.9	4.8	5.4	6.1	7.6	8.8	10.1	11.6	14.1	19.2	24.0	29.1	33.9	36.9	41.6	46.4	51.2	60.7	75.0
200	4.5	5.6	6.3	7.1	8.9	10.3	11.8	13.6	16.4	22.4	28.0	34.0	39.6	43.0	48.6	54.2	59.7	70.9	87.6
225	5.2	6.4	7.2	8.2	10.2	11.8	13.5	15.6	18.9	25.8	32.2	39.0	45.4	49.4	55.8	62.2	68.6	81.4	100.6
250	5.9	7.2	8.1	9.3	11.6	13.4	15.3	17.7	21.4	29.2	36.5	44.3	51.5	56.1	63.3	70.6	77.8	92.3	114.1
275	6.6	8.1	9.1	10.4	13.0	15.1	17.2	19.8	24.0	32.8	41.0	49.7	57.8	62.9	71.1	79.2	87.3	103.6	128.0
300	7.3	9.0	10.2	11.6	14.5	16.8	19.2	22.1	26.7	36.5	45.6	55.3	64.3	70.0	79.1	88.1	97.2	115.3	142.4
325	8.1	10.0	11.2	12.8	16.0	18.5	21.2	24.4	29.5	40.3	50.4	61.0	71.0	77.3	87.3	97.3	107.3	127.3	157.2
350	8.9	11.0	12.3	14.0	17.5	20.3	23.2	26.7	32.4	44.2	55.3	67.0	78.0	84.8	95.8	106.8	117.7	139.7	172.6
375	9.7	12.0	13.5	15.3	19.1	22.2	25.3	29.2	35.3	48.3	60.3	73.1	85.1	92.6	104.6	116.5	128.5	152.4	188.3
400	10.5	13.0	14.6	16.6	20.8	24.1	27.5	31.7	38.4	52.4	65.5	79.4	92.4	100.5	113.6	126.6	139.6	165.6	204.5

Table 1-C Heat Loss for Pipes (Watts Per Foot) Insulation Thickness 2"

ΔT	NPS Pipe Size																		
	0.25	0.5	0.75	1	1.5	2	2.5	3	4	6	8	10	12	14	16	18	20	24	30
25	0.4	0.5	0.6	0.6	0.8	0.9	1.0	1.2	1.4	1.9	2.4	2.8	3.3	3.6	4.0	4.5	4.9	5.8	7.1
50	0.9	1.1	1.2	1.3	1.6	1.9	2.1	2.4	2.9	3.9	4.8	5.8	6.7	7.3	8.2	9.1	10.1	11.9	14.6
75	1.3	1.6	1.8	2.0	2.5	2.9	3.3	3.7	4.4	6.0	7.4	8.9	10.3	11.2	12.6	14.0	15.5	18.3	22.5
100	1.8	2.2	2.5	2.8	3.4	3.9	4.4	5.1	6.1	8.2	10.1	12.2	14.1	15.3	17.2	19.2	21.1	24.9	30.7
125	2.3	2.8	3.2	3.6	4.4	5.0	5.7	6.5	7.8	10.4	12.9	15.6	18.0	19.6	22.1	24.5	27.0	31.9	39.3
150	2.9	3.5	3.9	4.4	5.4	6.2	7.0	8.0	9.5	12.8	15.9	19.1	22.1	24.0	27.1	30.1	33.1	39.2	48.2
175	3.4	4.1	4.6	5.2	6.4	7.3	8.3	9.5	11.4	15.3	18.9	22.8	26.4	28.7	32.3	35.9	39.5	46.7	57.5
200	4.0	4.8	5.4	6.1	7.5	8.6	9.7	11.1	13.3	17.9	22.1	26.6	30.8	33.5	37.7	41.9	46.1	54.5	67.1
225	4.6	5.6	6.2	7.0	8.6	9.9	11.2	12.7	15.2	20.5	25.4	30.6	35.4	38.5	43.3	48.1	53.0	62.6	77.1
250	5.2	6.3	7.0	7.9	9.7	11.2	12.6	14.4	17.3	23.3	28.8	34.7	40.2	43.6	49.1	54.6	60.1	71.1	87.5
275	5.8	7.1	7.9	8.9	10.9	12.5	14.2	16.2	19.4	26.1	32.3	38.9	45.1	49.0	55.1	61.3	67.4	79.7	98.2
300	6.5	7.9	8.8	9.9	12.2	14.0	15.8	18.0	21.6	29.1	36.0	43.3	50.2	54.5	61.3	68.2	75.0	88.7	109.2
325	7.2	8.7	9.7	10.9	13.4	15.4	17.5	19.9	23.9	32.1	39.8	47.8	55.4	60.2	67.7	75.3	82.9	98.0	120.7
350	7.9	9.6	10.7	12.0	14.7	16.9	19.2	21.9	26.2	35.2	43.6	52.5	60.8	66.0	74.4	82.7	91.0	107.6	132.4
375	8.6	10.4	11.6	13.1	16.1	18.5	20.9	23.9	28.6	38.5	47.6	57.3	66.4	72.1	81.2	90.2	99.3	117.4	144.5
400	9.3	11.3	12.6	14.2	17.5	20.1	22.7	25.9	31.0	41.8	51.7	62.2	72.1	78.3	88.2	98.0	107.8	127.5	157.0

CONTINUED

Heat Loss Tables

Heat Loss Tables

Continued from previous page...

Table 1-D Heat Loss for Pipes (Watts Per Foot) Insulation Thickness 2.5"

ΔT	NPS Pipe Size																		
	0.25	0.5	0.75	1	1.5	2	2.5	3	4	6	8	10	12	14	16	18	20	24	30
25	0.4	0.5	0.5	0.6	0.7	0.8	0.9	1.0	1.2	1.6	2.0	2.4	2.7	2.9	3.3	3.7	4.0	4.7	5.8
50	0.8	1.0	1.1	1.2	1.4	1.6	1.8	2.1	2.5	3.3	4.0	4.8	5.6	6.0	6.8	7.5	8.2	9.7	11.9
75	1.2	1.5	1.6	1.8	2.2	2.5	2.8	3.2	3.8	5.0	6.2	7.4	8.5	9.2	10.4	11.5	12.6	14.9	18.3
100	1.7	2.0	2.2	2.5	3.0	3.4	3.8	4.4	5.2	6.9	8.4	10.1	11.6	12.6	14.2	15.7	17.3	20.3	25.0
125	2.1	2.6	2.8	3.2	3.8	4.4	4.9	5.6	6.6	8.8	10.8	12.9	14.9	16.1	18.1	20.1	22.1	26.0	31.9
150	2.6	3.1	3.5	3.9	4.7	5.4	6.0	6.8	8.1	10.8	13.2	15.8	18.3	19.8	22.2	24.6	27.1	31.9	39.2
175	3.1	3.7	4.1	4.6	5.6	6.4	7.2	8.1	9.7	12.8	15.8	18.9	21.8	23.6	26.5	29.4	32.3	38.0	46.7
200	3.6	4.4	4.8	5.4	6.6	7.5	8.4	9.5	11.3	15.0	18.4	22.0	25.4	27.5	30.9	34.3	37.7	44.4	54.5
225	4.2	5.0	5.6	6.2	7.5	8.6	9.6	10.9	13.0	17.2	21.1	25.3	29.2	31.6	35.5	39.4	43.2	51.0	62.6
250	4.7	5.7	6.3	7.0	8.5	9.7	10.9	12.4	14.7	19.5	24.0	28.7	33.1	35.8	40.2	44.6	49.0	57.8	70.9
275	5.3	6.4	7.1	7.9	9.6	10.9	12.3	13.9	16.5	21.9	26.9	32.2	37.1	40.2	45.2	50.1	55.0	64.9	79.6
300	5.9	7.1	7.9	8.8	10.7	12.1	13.6	15.5	18.3	24.4	29.9	35.8	41.3	44.7	50.2	55.7	61.2	72.1	88.5
325	6.5	7.8	8.7	9.7	11.8	13.4	15.1	17.1	20.2	26.9	33.0	39.5	45.6	49.4	55.5	61.5	67.6	79.6	97.7
350	7.2	8.6	9.5	10.6	12.9	14.7	16.5	18.7	22.2	29.5	36.3	43.4	50.0	54.2	60.9	67.5	74.1	87.4	107.2
375	7.8	9.4	10.4	11.6	14.1	16.0	18.0	20.4	24.2	32.2	39.6	47.3	54.6	59.1	66.4	73.6	80.9	95.4	117.0
400	8.5	10.2	11.3	12.6	15.3	17.4	19.6	22.2	26.3	35.0	43.0	51.4	59.3	64.2	72.1	80.0	87.8	103.5	127.1

Table 1-E Heat Loss for Pipes (Watts Per Foot) Insulation Thickness 3"

ΔT	NPS Pipe Size																		
	0.25	0.5	0.75	1	1.5	2	2.5	3	4	6	8	10	12	14	16	18	20	24	30
25	0.4	0.4	0.5	0.5	0.6	0.7	0.8	0.9	1.1	1.4	1.7	2.0	2.3	2.5	2.8	3.1	3.4	4.0	4.9
50	0.7	0.9	1.0	1.1	1.3	1.5	1.6	1.9	2.2	2.9	3.5	4.2	4.8	5.2	5.8	6.4	7.0	8.3	10.1
75	1.1	1.4	1.5	1.7	2.0	2.3	2.5	2.8	3.3	4.4	5.4	6.4	7.3	7.9	8.9	9.8	10.8	12.7	15.5
100	1.6	1.9	2.0	2.3	2.7	3.1	3.4	3.9	4.6	6.0	7.3	8.7	10.0	10.8	12.1	13.4	14.7	17.3	21.2
125	2.0	2.4	2.6	2.9	3.5	3.9	4.4	5.0	5.8	7.7	9.4	11.1	12.8	13.8	15.5	17.2	18.8	22.1	27.1
150	2.4	2.9	3.2	3.6	4.3	4.8	5.4	6.1	7.2	9.4	11.5	13.7	15.7	17.0	19.0	21.1	23.1	27.1	33.2
175	2.9	3.5	3.8	4.2	5.1	5.8	6.4	7.3	8.5	11.2	13.7	16.3	18.7	20.2	22.7	25.1	27.5	32.3	39.6
200	3.4	4.0	4.5	4.9	5.9	6.7	7.5	8.5	10.0	13.1	16.0	19.0	21.9	23.6	26.5	29.3	32.1	37.8	46.2
225	3.9	4.6	5.1	5.7	6.8	7.7	8.6	9.7	11.5	15.0	18.4	21.8	25.1	27.1	30.4	33.6	36.9	43.4	53.1
250	4.4	5.3	5.8	6.4	7.7	8.8	9.8	11.0	13.0	17.1	20.8	24.8	28.5	30.8	34.5	38.1	41.8	49.2	60.2
275	5.0	5.9	6.5	7.2	8.7	9.8	11.0	12.4	14.6	19.1	23.4	27.8	31.9	34.5	38.7	42.8	46.9	55.2	67.5
300	5.5	6.6	7.2	8.0	9.7	10.9	12.2	13.8	16.2	21.3	26.0	30.9	35.5	38.4	43.0	47.6	52.2	61.4	75.1
325	6.1	7.3	8.0	8.9	10.7	12.1	13.5	15.2	17.9	23.5	28.7	34.1	39.2	42.4	47.5	52.6	57.6	67.7	82.9
350	6.7	8.0	8.8	9.7	11.7	13.2	14.8	16.7	19.6	25.8	31.5	37.5	43.1	46.5	52.1	57.7	63.2	74.3	91.0
375	7.3	8.7	9.6	10.6	12.8	14.5	16.2	18.2	21.4	28.2	34.4	40.9	47.0	50.8	56.9	62.9	69.0	81.1	99.3
400	7.9	9.4	10.4	11.6	13.9	15.7	17.5	19.8	23.3	30.6	37.3	44.4	51.0	55.2	61.8	68.4	74.9	88.1	107.8

Table 2 Insulation Factor

Insulation Material	Temperature (°F) to be Maintained								
	50	100	150	200	250	300	400	500	600
Fiberglass	1	1	1	1	1	1	1	1	1
Cellular Glass	1.53	1.50	1.48	1.44	1.42	1.40	1.36	1.34	1.32
Calcium Silicate	1.47	1.47	1.45	1.44	1.41	1.39	1.34	1.32	1.30
Polyurethane	0.60	0.60	0.58	0.57	*	*	*	*	*

* Temperature (°F) exceeds the recommended values for foam.



Note: All insulation factors were determined based on leading insulation manufacturers' specifications.



Heat Loss Tables

Table

3 Spiral Pitch (Feet of Heat Trace Cable Per Foot of Pipe)

Pitch	NPS Pipe Size																	
	0.50	0.75	1.00	1.50	2.00	2.5	3	4	6	8	10	12	14	16	18	20	24	30
2"	1.98	2.27	2.66	3.52	4.25	5.01	5.97	7.52	10.85	13.98	17.30	20.43	22.39	25.53	28.67	31.81	38.09	47.50
3"	1.52	1.69	1.92	2.46	2.93	3.43	4.05	5.07	7.27	9.35	11.56	13.64	14.95	17.04	19.13	21.22	25.40	31.68
4"	1.32	1.43	1.59	1.96	2.29	2.65	3.11	3.86	5.49	7.04	8.69	10.25	11.23	12.80	14.36	15.93	19.06	23.77
5"	1.21	1.29	1.40	1.68	1.93	2.21	2.56	3.15	4.43	5.67	6.98	8.23	9.00	10.25	11.50	12.76	15.26	19.02
6"	1.15	1.21	1.29	1.51	1.70	1.92	2.20	2.68	3.74	4.75	5.84	6.88	7.52	8.56	9.60	10.64	12.73	15.86
7"	1.11	1.16	1.22	1.39	1.55	1.72	1.96	2.35	3.24	4.11	5.03	5.92	6.47	7.36	8.25	9.14	10.92	13.61
8"	1.09	1.12	1.17	1.31	1.44	1.58	1.78	2.12	2.88	3.63	4.43	5.20	5.68	6.46	7.23	8.01	9.57	11.92
9"	1.07	1.10	1.14	1.25	1.36	1.48	1.65	1.94	2.60	3.26	3.97	4.64	5.07	5.76	6.45	7.14	8.52	10.60
10"	1.06	1.08	1.11	1.21	1.30	1.40	1.54	1.80	2.38	2.96	3.60	4.20	4.58	5.20	5.82	6.44	7.68	9.55
11"	1.05	1.07	1.10	1.17	1.25	1.34	1.46	1.68	2.20	2.72	3.30	3.84	4.19	4.75	5.30	5.87	6.99	8.69
12"	SR	SR	1.08	1.15	1.21	1.29	1.40	1.60	2.06	2.53	3.05	3.55	3.86	4.37	4.88	5.39	6.42	7.98
14"	SR	SR	1.06	1.11	1.16	1.22	1.31	1.46	1.84	2.23	2.66	3.08	3.35	3.78	4.21	4.65	5.53	6.86
16"	SR	SR	1.05	1.09	1.13	1.17	1.24	1.37	1.68	2.01	2.38	2.74	2.97	3.34	3.72	4.10	4.86	6.02
18"	SR	SR	SR	1.07	1.10	1.14	1.19	1.30	1.56	1.84	2.16	2.48	2.68	3.01	3.34	3.67	4.35	5.37
24"	SR	SR	SR	SR	1.06	1.08	1.11	1.18	1.35	1.53	1.75	1.97	2.12	2.35	2.59	2.83	3.33	4.08
30"	SR	SR	SR	SR	SR	1.05	1.07	1.12	1.23	1.37	1.52	1.69	1.80	1.97	2.16	2.34	2.73	3.32
36"	SR	SR	SR	SR	SR	SR	1.05	1.08	1.17	1.26	1.39	1.51	1.60	1.73	1.88	2.03	2.34	2.82
42"	SR	SR	SR	SR	SR	SR	SR	1.06	1.12	1.20	1.29	1.39	1.46	1.57	1.69	1.81	2.07	2.47
48"	SR	SR	SR	SR	SR	SR	SR	1.05	1.10	1.16	1.23	1.31	1.37	1.46	1.56	1.66	1.88	2.22
60"	SR	SR	SR	SR	SR	SR	SR	SR	1.05	1.10	1.15	1.21	1.25	1.31	1.38	1.46	1.62	1.87
72"	SR	SR	SR	SR	SR	SR	SR	SR	SR	1.07	1.11	1.15	1.18	1.23	1.28	1.33	1.46	1.66

SR = Straight Run

Table

4 Heat Loss Multiplication Factors for Valves

NPS Pipe Size	Multi. Factor	NPS Pipe Size	Multi. Factor	NPS Pipe Size	Multi. Factor	NPS Pipe Size	Multi. Factor
0.5	0.52	2	1.92	6	3.84	16	7.91
0.75	0.78	2.5	2.00	8	4.66	18	8.84
1	1.00	3	2.40	10	5.51	20	9.57
1.25	1.33	3.5	2.62	12	6.25	24	11.09
1.5	1.70	4	2.92	14	7.07		

Heat Trace Cable



Constant Wattage Heating Cable

Constant Wattage Heat Trace Cable

Tempco's Constant Wattage Heating Cables are all parallel resistance, low watt density electrical heaters designed to be cut to the desired lengths in the field, eliminating the need for prefabrications and reducing or eliminating many design and installation costs. No special training is required.

All Tempco Heating Cables are parallel circuit designed. The multi-stranded bus wires are covered in a high dielectric insulation. Spirally wrapped resistance wire maintains circuit continuity by connecting short, alternately spaced sections of exposed conductor bus wire. Cables feature moisture and chemical resistance

and are classed for hazardous locations when properly cut and spliced using the correct lead termination kit.

Metal Overbraid is provided on all heat tracing as standard to meet NEC code for grounding. The braid provides mechanical protection as well as a low resistance grounding path.

Tempco constant wattage heating cables are designed for a full range of applications. Whether your need is freeze protection or process temperature control of pipelines, water lines, oil lines or asphalt lines, Tempco has the cable for your special needs.



KE Style Heating Cables Maximum Temperature: 500°F (260°C)

The KE Style cable heating element is tension wrapped and covered with two layers of Kapton® film applied in reverse directions, then heat fused for moisture protection. A tinned copper overbraid is then added for additional abrasion protection and for a ground return path. The overbraid is further enclosed in a covering of 20 mm extruded Teflon® PFA for additional chemical and abrasion resistance.

Design Features

- * Temperature exposure rating 500°F (260°C)
- * Continuous electrical ground
- * Excellent moisture and chemical resistance
- * Hazardous location rating
- * FM approved

Typical Applications

- ↔ Oil Refineries
- ↔ Asphalt Plants
- ↔ Severe Arctic Cold
- ↔ Mines
- ↔ Pulp and Paper Mills
- ↔ Corrosive Environments
- ↔ Explosive Environments

Specifications

- Voltages Available:** 120, 208, 240, 480
- Wattages:** 4, 8, 12 (W/ft.)
- Outside Dimensions:** Nom. .330" x .225"
- Exposure Rating:** 500°F (260°C)
- De-Energized:** 550°F (302°C)
- Standard Metal Overbraid:** Tinned Copper
- Extruded Jacket:** Teflon®
- Moisture and Chemical Resistance:** Excellent
- Flame Resistance:** Outstanding
- Radiation Resistance:** Fair to Good

Agency Approvals

- * IEEE Std 515
- * Factory Mutual
 - Ordinary Locations
 - Hazardous Locations:
 - Class I, Division 2, Groups B, C & D
 - Class II, Division 2
 - Class III, Division 2

Ordering Information

Tempco's KE Constant Wattage Heat Trace Cable is sold by part number and length. The cable part number is put together as follows:

H T P 0 1

Wattage — watts/ft.

- 4 W/ft. = 4
- 8 W/ft. = 8
- 12 W/ft. = 2

Voltage

- 120 VAC = 1
- 240 VAC = 2
- 208 VAC = 3
- 480 VAC = 4

Outer Layer

- 0 = Standard Tinned Copper Braid



Note: Due to code requirements, KE cable has a metal overbraid.

WARNING: Cancer and Reproductive Harm - www.P65Warnings.ca.gov.

Constant Wattage Heat Trace Cable

FE Style Heating Cable Maximum Temperature: 400°F (204°C)

The FE Style cable heating element is tension wrapped and covered with a fluorocarbon film and enclosed in a minimum 20 mm Teflon® FEP abrasion resistant extruded jacket. This tough outer cover provides moisture and dielectric protection as well as resistance to abrasion. A layer of tinned copper braid is then applied to meet NEC code and to provide mechanical protection as well as a low resistance to ground.



Design Features

- * **Temperature Exposure Rating 400°F (204°C)**
- * **Ease of installation—cut to length at the job site**
- * **Moisture and chemical resistant**
- * **Stands up to repeated handling and flexing**
- * **Field proven industrial grade construction**
- * **Single end power connection**

Typical Applications

- ✦ **Mid-Temperature Control**
- ✦ **Food Processing Plants**
- ✦ **Freeze Protection**
- ✦ **Chemical Processing Plants**
- ✦ **Hazardous Locations**
- ✦ **Water Lines/Condensate Return Lines**

Specifications

- Voltages Available:** 120, 208, 240, 480V
- Wattages:** 3, 5, 8, 12 (W/ft.)
- Outside Dimensions:** Nom. .300" x .200"
- Exposure Rating:** 400°F (204°C)
- De-Energized:** 450°F (232°C)
- Standard Metal Overbraid:** Tinned Copper (Optional Stainless Steel)
- Moisture and Chemical Resistance:** Excellent
- Flame Resistance:** Outstanding
- Radiation Resistance:** Fair to Good

Agency Approvals

- * **Factory Mutual**
Ordinary Locations
Hazardous Locations:
Class I, Division 2, Groups B, C & D
Class II, Division 2, Groups E, F & G
Class III, Division 2
- * **CSA (120 and 240 VAC only)**
Ordinary Locations
Hazardous Locations:
Class I, Division 2, Groups B, C & D
Class II, Division 2, Groups F & G
Class III, Division 2



Ordering Information

Tempco's FE Constant Wattage Heat Trace Cable is sold by part number and length. The cable part number is put together as follows:

H T P 0 2

Wattage—watts/ft.

- 3 W/ft. = 3
- 5 W/ft. = 5
- 8 W/ft. = 8
- 12 W/ft. = 2

Voltage

- 120 VAC = 1
- 240 VAC = 2
- 208 VAC = 3
- 480 VAC = 4

Outer Layer

- 0 = Standard Tinned Copper Braid
- 3 = Stainless Steel Braid



Note: Due to code requirements, FE cable has a metal overbraid.

⚠ WARNING: Cancer and Reproductive Harm - www.P65Warnings.ca.gov.

(800) 323-6859 • Email: sales@tempco.com

Lead Termination and Cable Kits for Constant Wattage Cables

In order to maintain the integrity of the insulation, termination kits must be used to add leads or splice the heating cables. **Both ends must be terminated to use the heat trace cable properly.** The termination kits are designed to fully seal using a general purpose silicone RTV sealant, such as GE RTV108, on the final connections.

Termination Kit Type	"KE" Cable	"FE" Cable
Universal Connection/ Termination Kit	HTP90001	HTP90006
Lead and End Kit	HTP90002	HTP90007
Single Lead Term.	HTP90003	HTP90008
Single End Term.	HTP90004	HTP90009
Cable Splice Kit	HTP90005	HTP90010

The **Universal Kit** is mainly used to terminate the heat trace cable for pipe trace heating when the heating cable needs to terminate in an NPT pipe standoff for attaching a wiring junction box. The kit includes the 1" NPT pipe standoff and materials to make one power input connection, and two end terminations or one power input splice. The junction box is ordered separately; see page 6-13. These assemblies are watertight and suitable for use in Division II hazardous locations.

The **Lead and End Kit**, **Single Lead Termination Kit** and **Single End Termination Kits** are used when only simple cold power leads are required. The lead wire is customer supplied. The non-lead end must also be terminated and sealed.

The **Lead and End Kit** contains enough material for 5 lead and 5 end terminations.

The **Single Termination Lead Kit** and the **Single End Termination Kit** contain enough material for 1 lead or 1 end termination.

The **Splice Kit** is used to create one in-line splice or one "T" splice between two heat cables. May require pipe standoff, straps, junction box, and RTV (ordered separately, see page 6-13).

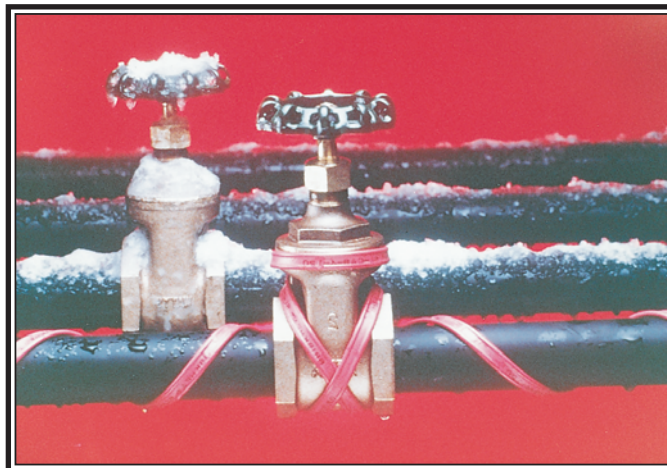

Self-Limiting Heat Trace Cable

Tempco's Self-Limiting Heating Cables are all parallel resistance, low watt density electrical heaters designed to be cut to the desired lengths in the field, eliminating the need for prefabrications and reducing or eliminating many design and installation costs. No special training is required.

Self-limiting heating cables are designed and built to regulate their output. As the process temperature drops, the cable's output increases; conversely, as the temperature rises, the cable's output decreases.

The self-limiting core is in essence an infinite number of parallel resistors that permit the cable to be cut to any length without creating cold sections. Because it is self-regulating and infinitely paral-

lel, the output varies along the length of the cable, depending upon local process temperature.

Metal overbraid is provided on all heat trace cabling to meet NEC code for grounding. The braid provides mechanical protection, as well as a low resistance grounding path.

On SL self-limiting cable, in addition to the standard metal overbraid, an optional thermoplastic elastomer or fluoropolymer outer jacket is recommended when exposure to organic chemicals or corrosives is expected.

Self-limiting heating cable provides safe, reliable heat tracing for process temperature maintenance and freeze protection of pipes, valves and similar applications.



Design Features

- * *Efficient, Safe, Easy to Install*
- * *Maintenance Temperatures up to 150°F (65°C)*
- * *Can Be Overlapped*
- * *Cut to Length at the Job Site*

Typical Applications

- ↪ *Pipelines*
- ↪ *Drains*
- ↪ *Water Lines*
- ↪ *Safety Showers*
- ↪ *Sprinkler Systems*

Specifications

- Voltages Available:** 120, 240
- Wattages:** 3, 5, 8, 10 (W/ft.) @ 50°F ambient
- Outside Dimensions:** Nom. .450" x .130"
- Exposure Rating:** 150°F (65°C)
- De-Energized:** 185°F (85°C)
- Standard Metal Overbraid:** Tinned Copper or optional Stainless Steel
- Moisture Resistance:** Excellent
- Chemical Resistance:** Good
- Flame Resistance:** Good
- Radiation Resistance:** Fair

Agency Approvals

- * CSA
- * IEEE Std 515 RU
- * **Factory Mutual**
 - Ordinary Locations
 - Hazardous Locations:
 - Class I, Division 2, Groups B, C & D
 - Class II, Division 2, Groups F & D
 - Class III, Division 1 and Division 2

Actual Wattage Output vs. Temperature

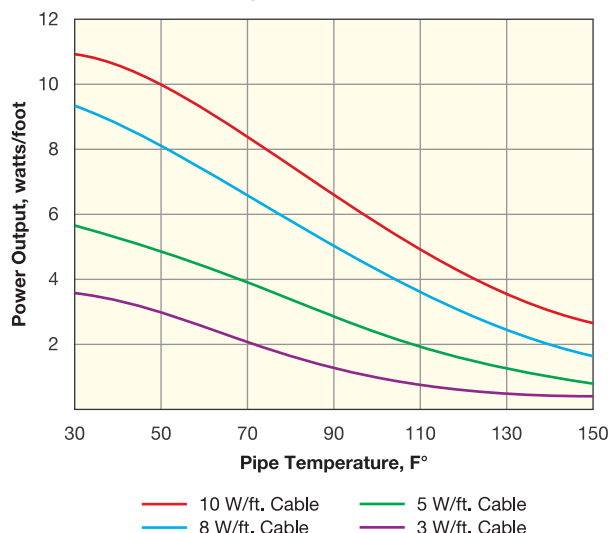

SL Style Heating Cable

The SL Style cable heating element is a low watt density parallel circuit electrical heater. The multi-stranded bus wires are extruded in an irradiated self-regulating conductive polyolefin that increases and decreases its heat output with changes in the ambient temperature. A flame retardant thermoplastic elastomer jacket is added for abrasion and impact resistance.

A metal braided shield is then applied to meet NEC code for grounding. Metal overbraid heaters are FM approved for use in hazardous areas.

An optional fluoropolymer outer jacket is also available. This outer jacket should be specified when the metal braided cable is installed in corrosive environments.



Self-Limiting Heat Trace Cable

Continued from previous page...

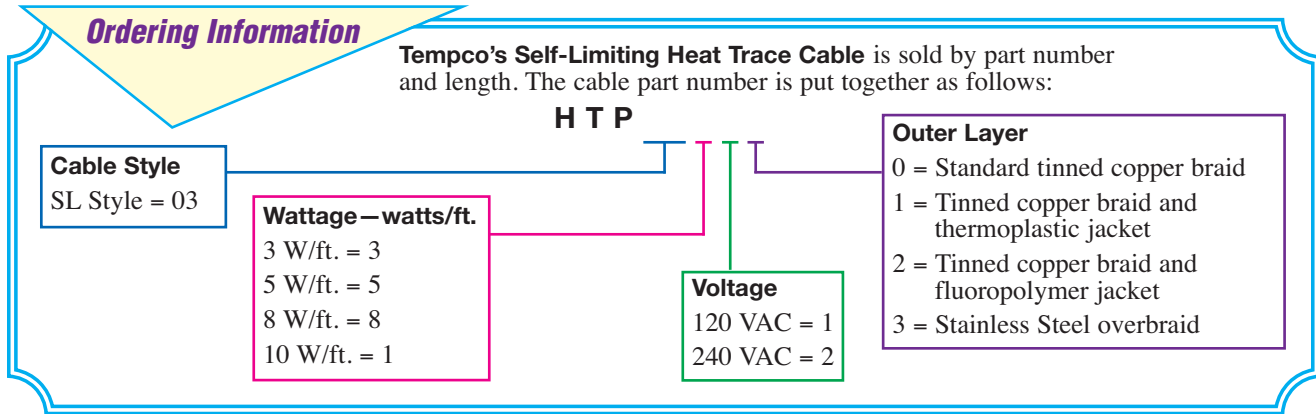

⚠ WARNING: Cancer and Reproductive Harm - www.P65Warnings.ca.gov.

Lead Termination and Cable Kits for Self-Limiting Cable

In order to maintain the integrity of the insulation, termination kits must be used to add leads or splice the heating cables. **Both ends must be terminated to use the heat trace cable properly.** The termination kits are designed to fully seal using a general purpose silicone RTV sealant, such as GE RTV108, on the final connections.

Termination Kit Type	"SL" Cable
Universal Connection/ Termination Kit	HTP90021
Splice or Lead End Kit	HTP90022
End Seal Kit	HTP90023

The **Universal Kit** is mainly used to terminate the heat trace cable for pipe trace heating when the heating cable needs to terminate in an NPT pipe standoff for attaching a wiring junction box. The SL kit includes the 1" NPT pipe standoff and materials to make one power input connection, and two end terminations or one power input splice. The junction box is ordered separately; see page 6-13. These assemblies are watertight and suitable for use in Division II hazardous locations.

The **Splice or Lead End Kit** is used for tee splices or cold lead end terminations. Enough material is supplied for 10 tee splices or 10 cold lead end terminations.

The **End Seal Kit** is used to cap off and seal the end of the cable where the bus wires are exposed. Enough material is supplied for 10 end seal terminations.



Temperature Controls and Accessories for Heat Trace Cables

Choosing the proper control depends first on the system requirements and second on the desired features and cost. Since Tempco's heat trace products are used primarily for freeze protection and to offset system heat loss, PID controls are generally not required.

The most economical is the pipe-mounted direct acting preset thermostat. Tempco offers a normally open/normally closed three wire model.

Where greater accuracy, faster response and larger ranges with adjustment capability are required, a bulb and capillary style thermostat fills the need. Tempco offers two types with NEMA 3R for general purpose and NEMA 4X where a fully sealed housing is required.

If the heat trace is used for process control and very accurate control is needed along with additional features, a thermocouple-based electronic PID controller is required.

See Section 13 – "Temperature Controllers" for more information.

Heating Cable Accessories		
Part Number	Accessory	Usage
HTP90028	Junction Box	For use with NPT pipe standoff Single hub - 1" NPT
HTP90029	Reducer	Adapts .75" NPT male to 1" NPT female
HTP90030	Aluminum Adhesive Tape 2" x 180 ft. 350°F/176°C	Helps to isolate the cable from insulation and aids in securing the cable to pipes and tanks.
HTP90031	Aluminum Adhesive Tape 2" x 180 ft. 550°F/288°C	Same as above

Action		Part No.
Closes	Opens	
35°F (2°C)	50°F (10°C)	HTP90104
45°F (7°C)	60°F (16°C)	HTP90105
60°F (16°C)	75°F (24°C)	HTP90106
90°F (32°C)	105°F (41°C)	HTP90107
185°F (85°C)	200°F (93°C)	HTP90108



This control is a preset, epoxy-sealed thermostat containing a hermetically sealed single pole, double throw switch with normally open and normally closed connections

Specifications

Voltage: Up to 277 VAC

Current: FM approved to 240 VAC at 25 amps

Leads: 36" long, 600 VAC 14 ga., 105°C PVC insulation

This control is an adjustable Stainless Steel bulb and capillary thermostat. It is enclosed in a NEMA 4X enclosure with a clear cover.

Specifications

Voltage: 120 or 240 VAC

Contacts: 120V SPST, 240V DPST

Current: 50 amps at either voltage

Leads: Hard wired directly to terminals

Dimensions: 6"H x 6"L x 5.87"W



Range		Part No.	
°F	°C	120V	240V
0 - 150	-18 - 66	HTP90113	HTP90116
50 - 300	10 - 149	HTP90114	HTP90117
150 - 650	66 - 343	HTP90115	HTP90118

Range		Part No.
°F	°C	
0 - 150	-18 - 66	HTP90109
100 - 250	38 - 121	HTP90110
200 - 350	93 - 177	HTP90111



This control is an adjustable bulb and capillary thermostat with single pole double throw contacts with NO and NC connections. It is enclosed in a NEMA 3R general purpose enclosure.

Specifications

Voltage: Up to 277 VAC

Current: 277 VAC at 22 amps

Leads: Hard wired directly to terminals

Dimensions: 3.30"H x 4.08"L x 4.08"W

Closed Cell Elastomeric Thermal Insulation

Design Features

- * *Cost Effective*
- * *Easy to install*
- * *Suitable for wide variety of environments, such as outdoor use and food service*
- * *Temperatures to 257°F (125°C)*
- * *UV resistant*
- * *Fiber Free*

Specifications

Material: 3/4" (19mm) thick closed-cell and lightweight EPDM based elastomeric material

Exposure Temperature Range: -297°F through 257°F

R-value: 3

Density: 3 to 6 Lbs/ft³

Water vapor permeability: 0.10 perm-in (0.15 x 10⁻¹²)

Water absorption (weight %): Less than 5%

Flammability: UL-94 5 V-A. V-O



Sheet Width in (mm)	Sheet Length ft (m)	Description	Part Number
11 (279)	50 (15.2)	Installs around 2.5" O.D. Pipes and smaller	HTP90050
15 (381)	50 (15.2)	Installs around 4" O.D. Pipes and smaller	HTP90051
48 (1219)	25 (7.6)	Installs around vessels and large diameter pipes	HTP90052

FOIL TAPE

Adhesive aluminum tape for extra environmental protection.
Up to 300°F (149°C).

Description	Part Number
3" (76mm) x 180 ft. (55m) roll. To protect insulation from environmental damage.	HTP90055



SEAM-SEALING TAPE

Adhesive tape required for sealing seams.
Up to 180°F (82°C).

Description in (mm)	Part Number
2" (51mm) x 82 ft. (25m) roll. Ideal for pipes and small vessels.	HTP90053
3" (76mm) x 82 ft. (25m) roll. Ideal for large vessels.	HTP90054

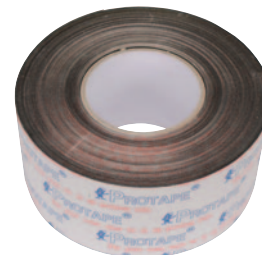

INSUL-LOCK® DS Flexible Closed Cell Pipe Insulation

Design Features

- * Easy to install with precise fit
- * Double Seal Technology
 - Built-in pressure sensitive adhesive
 - Built-in PVC overlap tape with acrylic adhesive
- * Scrim reinforcement on the seam surface
- * Non-porous, fiber-free, and resistant to mold growth
- * Resistant to moisture vapor flow
- * Compatible with heating cable and tapes

Specifications

Material: Environmentally-friendly, CFC-free, flexible elastomeric thermal insulation

Operating Temperature Range:
-70°F (-57°C) through 220°F (104°C)

R-value: 3

Color: Black

Length: 6.0 feet (1.8 meter)

Thickness: 0.5" (1.3 cm)

Density: 3 to 6 Lbs/ft³

Water vapor permeability:

Dry cup (Elastomeric insulation) 0.03 perm-in
Wet cup (Glued seam with overlap) 0.12 perm-in

Water absorption % (Volume change): 0

Flammability: UL-94 5 V-A, V-O



Typical Applications

- Freeze Protection
- Prevent condensation on refrigerant lines, cold water plumbing, roof drains, and chilled water systems
- Many other outdoor and indoor applications



Standard Closed Cell Pipe Insulation

Preformed pipe insulations are 1/2 inch thick, 6 foot long with overlap flap with Pressure Sensitive Adhesive (PSA).

Nominal ID	Nominal OD	Recommended for Pipe OD	Part Number
7/8"	2-1/8"	3/4"	HTP90060
1-1/8"	2-3/8"	1"	HTP90061
1-3/8"	2-5/8"	1-1/4"	HTP90062
1-5/8"	2-7/8"	1-1/2"	HTP90063
2"	3-1/8"	none	HTP90064
2-3/8"	3-1/2"	none	HTP90065
2-5/8"	4"	none	HTP90066
2-7/8"	4-1/8"	none	HTP90067
3-1/8"	4-1/2"	none	HTP90068
3-1/2"	5"	none	HTP90069



SEAM-SEALING TAPE

Seals spaces between multiple pieces of insulation and prevents heat loss.

.75" (51mm) x 180" (4.5 m) roll.

Part Number: HTP90058

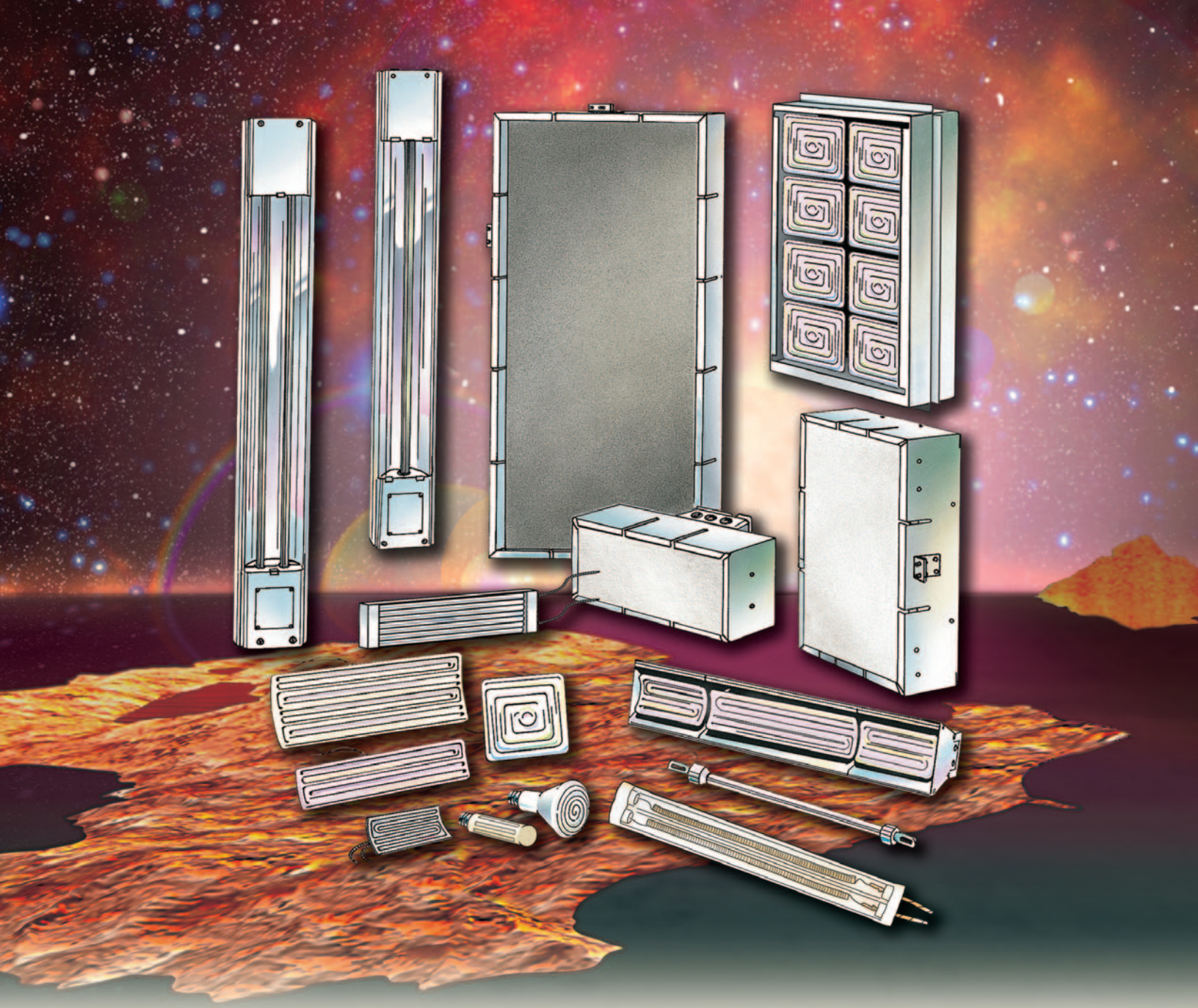

Table Of Contents

Pictorial Index	A-15	KTE and KTG Mini-Tube Quartz E-Mitters and Type ARV Arrays	7-42
CRL, CRB, CRM, CRC and CRS Curved Face Ceramic E-Mitters®	7-2	Sealed IR Quartz Lamps	7-52
CRG Flat Face Ceramic E-Mitters	7-9	VS Glow Infrared Heaters	7-58
CRH & CRD Flat Face Ceramic E-Mitters	7-10	Gemini Medium Wave Quartz Heaters ...	7-62
CRN & CRZ Flat Face Ceramic E-Mitters	7-12	KRD Radiant Quartz Tube Heaters	7-70
Type CRA Linear Structural Housings....	7-16	KRH Radiant Quartz Heater Assembly ...	7-72
E-Mitter Accessories	7-20	Tubular Infrared Radiant Process Heaters and Universal 2000 Replacement Elements	7-74
CRP Modular Panels	7-24	Infrared Medium Wave Panel Heaters....	7-88
Type ARA Structural Housing Assembly ..	7-28	Introduction to Infrared Radiation	7-96
CRE, CRR and CRT Screw-In Bulb Ceramic E-Mitters	7-38		

Radiant Heaters

7

section

Series CRL, CRB, CRM, CRC and CRS Curved Face Ceramic E-Mitters

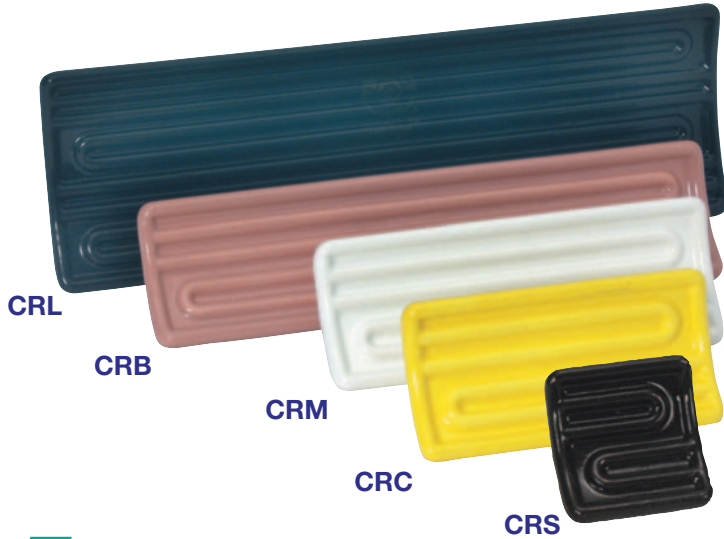

Design Features

- * Universal mount designed to be dropped into existing systems regardless of manufacturer.
- * Standard colors are metamorphing rose (cold) to grey (hot), and traditional white. Optional colors are metamorphing yellow (cold) to orange (hot), and black.
- * Standard stocked voltage: 120 or 220/240V as noted; other voltages are available.
- * Available with built-in type K thermocouple. Type J thermocouple is also available. Low noise options are also available.
- * Long operating life—over 10,000-plus hours of continuous operation under normal conditions
- * Performance is unaffected by vibration or adverse atmospheric conditions.
- * 2.5 to 6 μ m infrared radiation wavelength

5 Standard Solid Curved Face sizes to accommodate a wide range of new or existing applications

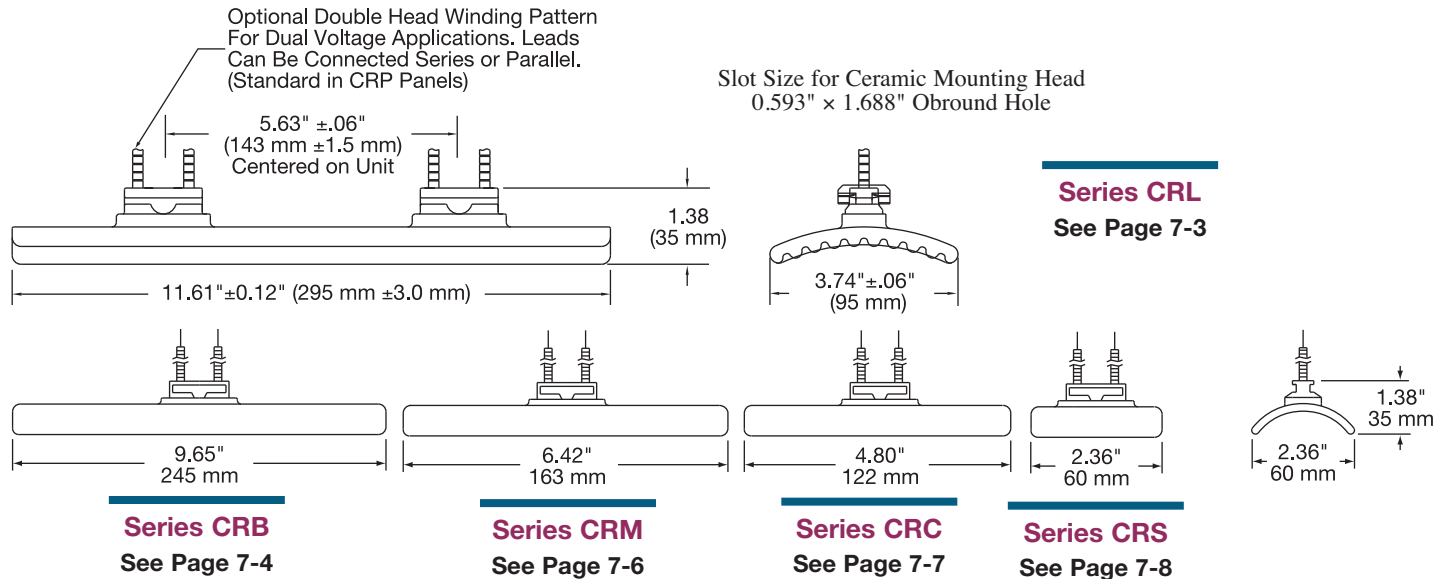

Ordering Information

Standard Heaters

Order by Part Number for Standard (Non-Stock) heaters.

Semi-Finished Stock CRB and CRC heaters ship in five business days. A Part Number will be assigned at time of order.

Custom Engineered/Manufactured Heaters

Understanding that an electric heater can be very application specific, for sizes and ratings not listed, **TEMPCO** can manufacture a Ceramic E-Mitter to meet your requirements. **Standard lead time is 3 weeks.**

Please Specify the following:

- Colors:** Standard are metamorphing rose and straight white, optional are metamorphing yellow and straight black
- Wattage:** Up to 43w/in² (6.7w/cm²)
- Voltage:** 120, 208, 240, 277, 480 and others (dependent on design)
- Thermocouple:** Standard Type K (Type J optional) or Low Noise Type K (Type J optional)
- Additional Options:** Start on page 7-20

⚠ WARNING: Cancer and Reproductive Harm - www.P65Warnings.ca.gov.



Series CRL Curved Face Ceramic E-Mitters – Size: 95 mm × 295 mm (3.74" × 11.61")

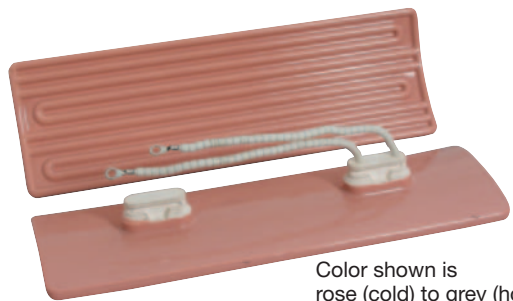

Color shown is rose (cold) to grey (hot)

Optional Features

- * *Additional Power or Thermocouple Lead Lengths (page 7-23)*
- * *Two-Piece Wave Mounting Clip (page 7-14)*
- * *Reflectors and Other Accessories (pages 7-20 through 7-23)*
- * *Arrays and Power/Temperature Control Panels (start on page 7-15)*

Standard (Non-Stock) CRL E-Mitters

E-Mitters listed have 6" ceramic bead insulated leads, #8-10 spade terminals, and one-piece spring clips for mounting in 20 or 22 gauge sheet metal.

Wattage	Voltage	Color	Watt Density*		Heater Body Temp.**		Peak Emitted Wavelength***	Part Number		
			(W/in ²)	(W/cm ²)	°F	°C		Without Thermocouple	Standard Type K Thermocouple	Low Noise Type K Thermocouple
500	120	Yellow to Orange	11.9	1.9	796	424	4.15	CRL20021	—	CRL20022
500	220-240	Rose to Grey	11.9	1.9	796	424	4.15	CRL10009	CRL10010	—
500	220-240	White	11.9	1.9	796	424	4.15	CRL00009	CRL00010	—
500	240/480	Yellow to Orange	11.9	1.9	796	424	4.15	CRL20023	—	CRL20024
750	120/240	Yellow to Orange	17.9	2.8	956	513	3.68	CRL20025	—	CRL20026
750	220-240	Rose to Grey	17.9	2.8	956	513	3.68	CRL10011	CRL10012	—
750	220-240	White	17.9	2.8	956	513	3.68	CRL00011	CRL00012	—
750	240/480	Yellow to Orange	17.9	2.8	956	513	3.68	CRL20027	—	CRL20028
950	220-240	Rose to Grey	22.7	3.5	1053	567	3.45	CRL10001	CRL10002	—
950	220-240	White	22.7	3.5	1053	567	3.45	CRL00001	CRL00002	—
1000	220-240	Rose to Grey	23.9	3.7	1076	580	3.40	CRL10013	CRL10014	—
1000	220-240	White	23.9	3.7	1076	580	3.40	CRL00013	CRL00014	—
1000	240/480	Yellow to Orange	23.9	3.7	1076	580	3.40	CRL20029	—	CRL20030
1150	220-240	Rose to Grey	27.5	4.3	1145	618	3.25	CRL10003	CRL10004	—
1150	220-240	White	27.5	4.3	1145	618	3.25	CRL00003	CRL00004	—
1250	240/480	Yellow to Orange	29.9	4.6	1191	644	3.16	CRL20031	—	CRL20032
1400	480	Rose to Grey	33.5	5.2	1262	683	3.03	CRL10015	CRL10016	—
1400	480	White	33.5	5.2	1262	683	3.03	CRL00015	CRL00016	—
1500	240/480	Yellow to Orange	35.9	5.6	1308	709	2.95	CRL20033	—	CRL20034
1600	480	Rose to Grey	38.2	5.9	1351	733	2.88	CRL10017	CRL10018	—
1600	480	White	38.2	5.9	1351	733	2.88	CRL00017	CRL00018	—
1800	480	Rose to Grey	43.0	6.7	1418	770	2.78	CRL10019	CRL10020	—
1800	480	White	43.0	6.7	1418	770	2.78	CRL00019	CRL00020	—

NOTES: All dual voltage heaters have two windings (parallel connected for the lower voltage & series connected for the higher voltage). Single voltage heaters are single winding designs.

Units with an internal “low noise” style thermocouple have 12" leads (see page 7-14). Standard type “K” T/C units also available.

Heaters with yellow to orange color are exact replacements for heaters in CRP Modular 12 × 12 CRP Radiant Panels on page 7-24.

* **Watt density**
calculated using heater face surface area.

** **E-Mitter heater body temperature**
as measured with internal thermocouple when mounted facedown in stock CRK reflector and operating in 72°F (22°C) room ambient.

*** **Peak infrared radiation wavelength** as calculated from Wien's Law, for operating temperature shown. Expressed in microns (μm).

Custom Heater Assemblies & Power Control Panels



Type CRA Custom Linear Arrays
start on page 7-18



Type ARA Custom Structural Arrays
start on page 7-28

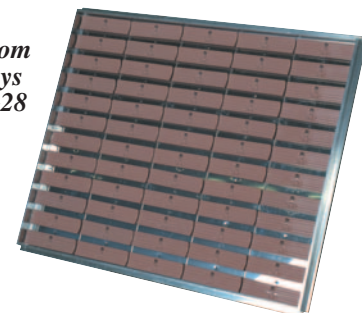

Array Power/Temperature Control Panels (see page 7-37)

(800) 323-6859 • Email: sales@tempco.com

Series CRB Curved Face Ceramic E-Mitters – Size: 60 mm × 245 mm (2.36" × 9.65")

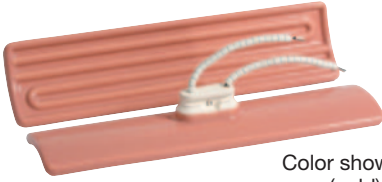

Color shown is
rose (cold) to grey (hot)

Optional Features

- * *Additional Power or Thermocouple Lead Lengths (page 7-23)*
- * *Two-Piece Wave Mounting Clip (page 7-14)*
- * *Reflectors and Other Accessories (pages 7-20 through 7-23)*
- * *Arrays and Power/Temperature Control Panels (start on page 7-15)*

Standard (Non-Stock) CRB E-Mitters

E-Mitters listed have 3.50" ceramic bead insulated leads, #8-10 spade terminals, and a one-piece spring clip for mounting.

Wattage	Voltage	Color	Watt Density*		Heater Body Temp.**		Part Number	
			(W/in ²)	(W/cm ²)	(Typical Operating) °F	°C	Without Thermocouple	With Type K Thermocouple
150	220/240	Rose to Grey	6.48	1.00	560	293	CRB10216	CRB10217
150	220/240	White	6.48	1.00	560	293	CRB00216	CRB00217
250	220/240	Rose to Grey	10.80	1.67	756	402	CRB10006	CRB10008
250	220/240	White	10.80	1.67	756	402	CRB00006	CRB00008
400	220/240	Rose to Grey	17.27	2.68	942	506	CRB10014	CRB10016
400	220/240	White	17.27	2.68	942	506	CRB00014	CRB00016
650	120	Rose to Grey	28.07	4.35	1156	624	CRB10020	CRB10022
650	120	White	28.07	4.35	1156	624	CRB00020	CRB00022
650	220/240	Rose to Grey	28.07	4.35	1156	624	CRB10023	CRB10025
650	220/240	White	28.07	4.35	1156	624	CRB00023	CRB00025
650	480	Rose to Grey	28.07	4.35	1156	624	CRB10088	CRB10165
650	480	White	28.07	4.35	1156	624	CRB00088	CRB00165
1000	120	Rose to Grey	43.18	6.69	1420	771	CRB10028	CRB10030
1000	120	White	43.18	6.69	1420	771	CRB00028	CRB00030
1000	220/240	Rose to Grey	43.18	6.69	1420	771	CRB10031	CRB10033
1000	220/240	White	43.18	6.69	1420	771	CRB00031	CRB00033
1000	480	Rose to Grey	43.18	6.69	1420	771	CRB10089	CRB10045
1000	480	White	43.18	6.69	1420	771	CRB00089	CRB00045

Semi-Finished Stock CRB E-Mitters (Five Business Day Manufacturing)

Semi-Finished Series CRB E-Mitters listed below are stocked ready for color glazing. Colors available are metamorphing rose (cold) to grey (hot), traditional white, metamorphing yellow (cold) to orange (hot), and black.

They can be terminated with beaded leads up to 6" long with spliced-on lead wire for lengths beyond 6" and straight, ring, or spade terminals. Some are available with a thermocouple (any length).

A part number will be assigned at time of order.

Wattage	Voltage	Watt Density*		Heater Body**		Optional Thermocouple (Any Length)
		(W/in ²)	(W/cm ²)	Temperature (Typical) °F	°C	
400	230	17.27	2.68	942	506	N/A
650	230	28.07	4.35	1156	624	Type K
650	480	28.07	4.35	1156	624	N/A
1000	230	43.18	6.69	1420	771	Type K
1000	480	43.18	6.69	1420	771	Type J or K

CRB Ordering Information (See page 7-2)

Series CRB Curved Face Ceramic E-Mitter Specifications

Series CRB – Size: 60 mm × 245 mm (2.36" × 9.65") Watts/Square Inch vs. Temperature Data

Watts	Surface W/in ² *	Heater Body °F Rise	Heater Body Temp @ 72°F**	Primary Emitted Wavelength*** (μm)
100	4.32	357	429	5.87
125	5.40	426	498	5.45
150	6.48	488	560	5.11
163	7.04	518	590	4.97
200	8.64	596	668	4.63
250	10.80	684	756	4.29
300	12.95	756	828	4.05
325	14.03	788	860	3.95
350	15.11	817	889	3.87
400	17.27	870	942	3.72
500	21.59	960	1032	3.50
600	25.91	1043	1115	3.31
650	28.07	1084	1156	3.23
700	30.23	1126	1198	3.15
750	32.39	1169	1241	3.07
800	34.55	1211	1283	2.99
875	37.78	1271	1343	2.89
900	38.86	1290	1362	2.86
1000	43.18	1348	1420	2.78

* **Watt density** calculated using heater face surface area.

** **E-Mitter heater body temperature** as measured with internal thermocouple when mounted facedown in stock CRK reflector and operating in 72°F (22°C) room ambient.

*** **Peak infrared radiation wavelength** as calculated from Wien's Law, for operating temperature shown. Expressed in microns (μm).

Typical Heating and Cooling Behavior of CRB Ceramic E-Mitters

Warm-Up Time Graph

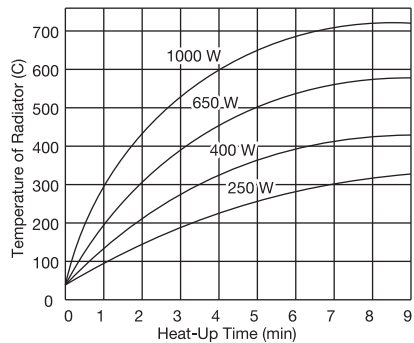

Cool-Down Time Graph

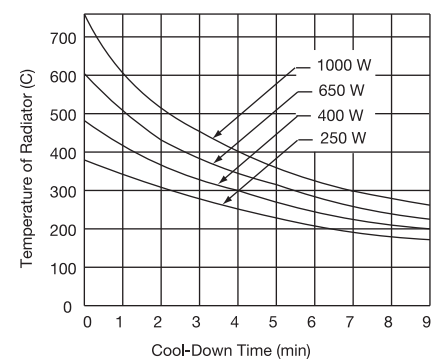

Radiant Process Heaters



Series CRM E-Mitters

Series CRM Curved Face Ceramic E-Mitters – Size: 60 mm × 163 mm (2.36" × 6.42")

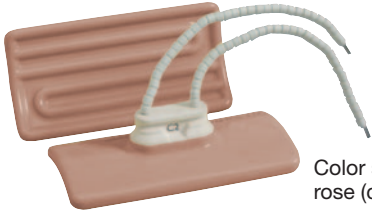

Color shown is
rose (cold) to grey (hot)

Optional Features

- * *Additional Power or Thermocouple Lead Lengths (page 7-23)*
- * *Two-Piece Wave Mounting Clip (page 7-14)*
- * *Reflectors and Other Accessories (pages 7-20 through 7-23)*
- * *Arrays and Power/Temperature Control Panels (start on page 7-15)*

Standard (Non-Stock) CRM E-Mitters

E-Mitters listed have 3.50" ceramic bead insulated leads,
#8-10 spade terminals, and a one-piece spring clip for mounting.

Wattage	Voltage	Color	Watt Density*		Heater Body Temp.**		Part Number	
			(W/in ²)	(W/cm ²)	°F	°C	Without Thermocouple	With Type K Thermocouple
425	120	Rose to Grey	27.44	4.25	1144	618	CRM10008	CRM10011
425	120	White	27.44	4.25	1144	618	CRM00008	CRM00011
500	120	Rose to Grey	32.28	5.00	1239	671	CRM10009	CRM10012
500	120	White	32.28	5.00	1239	671	CRM00009	CRM00012
600	220/240	Rose to Grey	38.74	6.00	1360	738	CRM10010	CRM10013
600	220/240	White	38.74	6.00	1360	738	CRM00010	CRM00013

Series CRM Curved Face Ceramic E-Mitter Specifications

Series CRM – Size: 60 mm × 163 mm (2.36" × 6.42")

Watts/Square Inch vs. Temperature Data

Watts	Surface W/in ² *	Heater Body °F Rise	Heater Body Temp @ 72°F**	Primary Emitted Wavelength*** (μm)
100	6.46	487	559	5.12
150	9.68	641	713	4.45
200	12.91	755	827	4.05
250	16.14	843	915	3.79
300	19.37	915	987	3.60
350	22.60	979	1051	3.45
400	25.82	1041	1113	3.32
450	29.05	1103	1175	3.19
500	32.28	1167	1239	3.07
550	35.51	1230	1302	2.96
600	38.74	1288	1360	2.87
650	41.96	1335	1407	2.79

* **Watt density** calculated using heater face surface area.

** **E-Mitter heater body temperature** as measured with internal thermocouple when mounted facedown in stock CRK reflector and operating in 72°F (22°C) room ambient.

*** **Peak infrared radiation wavelength** as calculated from Wien's Law, for operating temperature shown. Expressed in microns (μm).

CRM Ordering Information (See page 7-2)



Series CRC Curved Face Ceramic E-Mitters – Size: 60 mm × 122 mm (2.36" × 4.80")

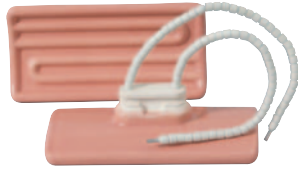

Color shown is rose (cold) to grey (hot)

Optional Features

- * Additional Power or Thermocouple Lead Lengths (page 7-23)
- * Two-Piece Wave Mounting Clip (page 7-14)
- * Reflectors and Other Accessories (pages 7-20 through 7-23)
- * Arrays and Power/Temperature Control Panels (start on page 7-15)

Standard (Non-Stock) CRC E-Mitters

E-Mitters listed have 3.50" ceramic bead insulated leads, #8-10 spade terminals, and a one-piece spring clip for mounting.

Wattage	Voltage	Color	Watt Density*		Heater Body Temp.**		Part Number	
			(W/in ²)	(W/cm ²)	(Typical Operating) °F	(Typical Operating) °C	Without Thermocouple	With Type K Thermocouple
125	220/240	Rose to Grey	10.80	1.67	756	402	CRC10005	CRC10007
125	220/240	White	10.80	1.67	756	402	CRC00005	CRC00007
200	220/240	Rose to Grey	17.27	2.68	942	506	CRC10013	CRC10015
200	220/240	White	17.27	2.68	942	506	CRC00013	CRC00015
325	120	Rose to Grey	28.07	4.35	1156	624	CRC10018	CRC10020
325	120	White	28.07	4.35	1156	624	CRC00018	CRC00020
325	220/240	Rose to Grey	28.07	4.35	1156	624	CRC10021	CRC10023
325	220/240	White	28.07	4.35	1156	624	CRC00021	CRC00023
325	480	Rose to Grey	28.07	4.35	1156	624	CRC10064	CRC10140
325	480	White	28.07	4.35	1156	624	CRC00064	CRC00140
500	120	Rose to Grey	43.18	6.69	1420	771	CRC10024	CRC10026
500	120	White	43.18	6.69	1420	771	CRC00024	CRC00026
500	220/240	Rose to Grey	43.18	6.69	1420	771	CRC10027	CRC10029
500	220/240	White	43.18	6.69	1420	771	CRC00027	CRC00029
500	480	Rose to Grey	43.18	6.69	1420	771	CRC10066	CRC10141

Semi-Finished Stock CRC E-Mitters (Five Business Day Manufacturing)

Semi-Finished Series CRC E-Mitters listed below are stocked ready for color glazing. Colors available are metamorphing rose (cold) to grey (hot), traditional white, metamorphing yellow (cold) to orange (hot), and black.

They can be terminated with beaded leads up to 6" long with spliced-on lead wire for lengths beyond 6" and straight, ring, or spade terminals. Some are available with a thermocouple (any length).

A part number will be assigned at time of order.

Wattage	Voltage	Watt Density*		Heater Body** Temperature (Typical)		Optional Thermocouple (Any Length)
		(W/in ²)	(W/cm ²)	°F	°C	
200	230	17.27	2.68	942	506	Type K
325	230	28.07	4.35	1156	624	Type K
325	480	28.07	4.35	1156	624	N/A
500	230	43.18	6.69	1420	771	Type K
500	480	43.18	6.69	1420	771	N/A

CRC Ordering Information (See page 7-2)

CONTINUED →

Series CRC Curved Face Ceramic E-Mitter Specifications

Continued from previous page...

Series CRC Curved Face Ceramic E-Mitters – Size: 60 mm × 122 mm (2.36" × 4.80")

Watts/Square Inch vs. Temperature Data

Watts	Surface W/in ² *	Heater Body °F Rise	Heater Body Temp @ 72°F**	Primary Emitted Wavelength*** (µm)
100	8.64	596	668	4.63
125	10.80	684	756	4.29
150	12.95	756	828	4.05
163	14.08	789	861	3.95
200	17.27	870	942	3.72
250	21.59	960	1032	3.50
300	25.91	1043	1115	3.31
325	28.07	1084	1156	3.23
350	30.23	1126	1198	3.15
375	32.39	1169	1241	3.07
400	34.55	1211	1283	2.99
500	43.18	1348	1420	2.78

Series CRS Curved Face Ceramic E-Mitters – Size: 60 mm × 60 mm (2.36" × 2.36")



Optional Features

- * Additional Power or Thermocouple Lead Lengths (page 7-23)
- * Two-Piece Wave Mounting Clip (page 7-14)
- * Reflectors and Other Accessories (pages 7-20 through 7-23)
- * Arrays and Power/Temperature Control Panels (start on page 7-15)

Standard (Non-Stock) CRS E-Mitters

E-Mitters listed have 3.50" ceramic bead insulated leads, #8-10 spade terminals, and a one-piece spring clip for mounting.

Wattage	Voltage	Color	Watt Density*		Part Number	
			(W/in ²)	(W/cm ²)	Without Thermocouple	With Type K Thermocouple
162	120	White	28.07	4.35	CRS00002	CRS00009
162	220/240	White	28.07	4.35	CRS00005	CRS00012
250	120	White	43.18	6.69	CRS00003	CRS00010
250	220/240	White	43.18	6.69	CRS00006	CRS00013

CRS Ordering Information (See page 7-2)



Series CRG Flat Face Ceramic E-Mitters – Size: 122 mm (4.80") square

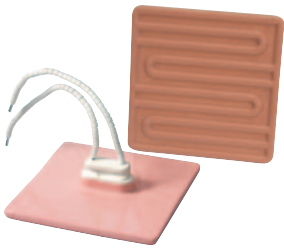

Color shown is rose (cold) to grey (hot)

Optional Features

- * *Additional Power or Thermocouple Lead Lengths (page 7-23)*
- * *Two-Piece Wave Mounting Clip (page 7-14)*
- * *Reflectors and Other Accessories (pages 7-20 through 7-23)*
- * *Arrays and Power/Temperature Control Panels (start on page 7-15)*

Standard (Non-Stock) CRG E-Mitters

E-Mitters listed have 3-1/2" ceramic bead insulated leads, #8-10 spade terminals, and a one-piece spring clip for mounting in 20 or 22 gauge sheet metal.

Wattage	Voltage	Color	Watt Density*		Heater Body Temp.**		Part Number	
			(W/in ²)	(W/cm ²)	(Typical Operating) °F	°C	Without Thermocouple	With Type K Thermocouple
250	220/240	Rose to Grey	10.9	1.7	758	403	CRG10026	CRG10027
250	220/240	White	10.9	1.7	758	403	CRG00026	CRG00027
325	220/240	Rose to Grey	14.1	2.2	862	461	CRG10028	CRG10029
325	220/240	White	14.1	2.2	862	461	CRG00028	CRG00029
400	220/240	Rose to Grey	17.4	2.7	944	507	CRG10030	CRG10031
400	220/240	White	17.4	2.7	944	507	CRG00030	CRG00031
650	220/240	Rose to Grey	28.2	4.4	1159	626	CRG10032	CRG10033
650	220/240	White	28.2	4.4	1159	626	CRG00032	CRG00033
800	220/240	Rose to Grey	34.7	5.4	1287	697	CRG10034	CRG10035
800	220/240	White	34.7	5.4	1287	697	CRG00034	CRG00035
1000	220/240	Rose to Grey	43.4	6.7	1422	772	CRG10036	CRG10037
1000	220/240	White	43.4	6.7	1422	772	CRG00036	CRG00037

Series CRG Flat Face Ceramic E-Mitter Specifications

Watts/Square Inch vs. Temperature Data

Watts	Surface W/in ² *	Heater Body °F Rise	Heater Body Temp @ 72°F**	Primary Emitted Wavelength*** (μ)
250	10.9	686	758	4.28
325	14.1	790	862	3.95
400	17.4	872	944	3.72
650	28.2	1087	1159	3.22
800	34.7	1215	1287	2.99
1000	43.4	1350	1422	2.77

* **Watt density** calculated using heater face surface area.

** **E-Mitter heater body temperature** as measured with internal thermocouple when mounted facedown in stock CRK reflector and operating in 72°F (22°C) room ambient.

*** **Peak infrared radiation wavelength** as calculated from Wien's Law, for operating temperature shown. Expressed in microns (μm).

Series CRG Dimensions

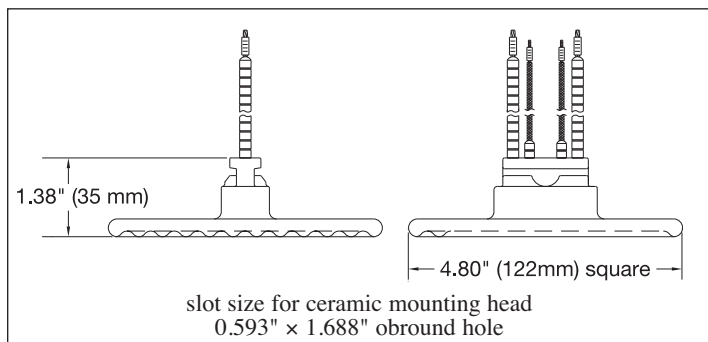

CRG Ordering Information

See page 7-2

Radiant Process Heaters



Series CRH, CRD E-Mitters

Insulated Flat Face Short Neck Series CRH and Long Neck Series CRD Ceramic E-Mitters



CRH shown in white and CRD in metamorphing rose (cold) to grey (hot)

CRH and CRD E-Mitter Construction

1. **LESS MASS.** A special manufacturing process allows construction with thin walls that withstand larger temperature gradients. The embedded resistance coils heat up the low mass body at a faster rate, providing considerable energy savings.
2. **SUPERIOR INSULATING MATERIAL.** The hollow inner area is filled with low-mass ceramic fiber to further insulate the contact region from the e-mitter surface, resulting in an improved operating life.

Design Features

- * *Universal mount designed to be dropped into existing systems regardless of manufacturer*
- * *Standard colors are metamorphing rose (cold) to grey (hot), and traditional white. Optional colors are metamorphing yellow (cold) to orange (hot), and black*
- * *Standard stocked voltage: 120 or 220/240V as noted; other voltages are available*
- * *Available with built-in type K thermocouple. Optional type J thermocouple is also available.*
- * *Long operating life – over 10,000-plus hours of continuous operation under normal conditions*
- * *Performance is unaffected by vibration or adverse atmospheric conditions*
- * *2.5 to 6µm infrared radiation wavelength*

Slot size for ceramic mounting heads
0.593" X 1.688" oblong hole

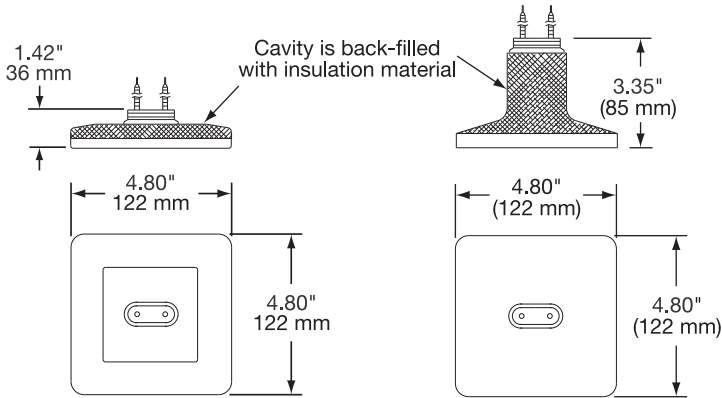

Series CRH Dimensions

Series CRD Dimensions

Optional Features

- * *Additional Power or Thermocouple Lead Lengths (page 7-23)*
- * *Two-Piece Wave Mounting Clip (page 7-14)*
- * *Reflectors and Other Accessories (pages 7-20 through 7-23)*
- * *Arrays and Power/Temperature Control Panels (start on page 7-15)*

Warm-up Curve
CRH Short Shaft

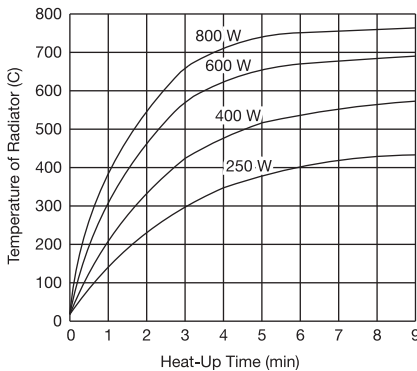

Cool-Down Curve
CRH Short Shaft

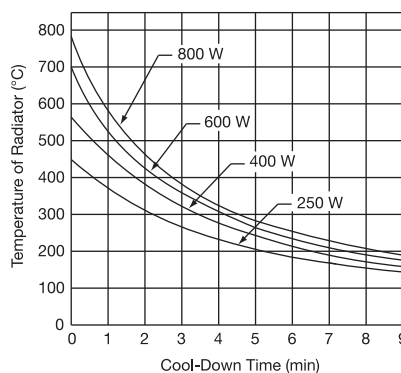

Warm-up Curve
CRD Long Shaft

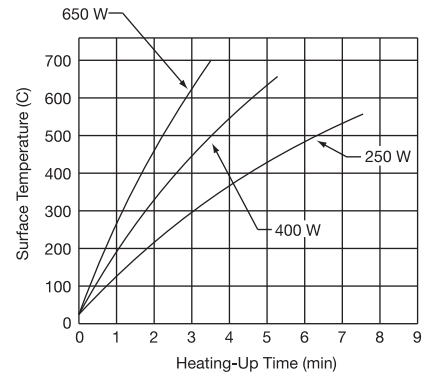



Series CRH E-Mitters – Size: 122 mm (4.80") square

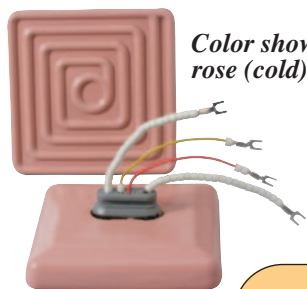

Color shown is rose (cold) to grey (hot)

Optional Features

- * Additional Power or Thermocouple Lead Lengths (page 7-23)
- * Two-Piece Wave Mounting Clip (page 7-14)
- * Reflectors and Other Accessories (pages 7-20 through 7-23)
- * Arrays and Power/Temperature Control Panels (start on page 7-15)

Standard (Non-Stock) CRH E-Mitters

E-Mitters listed have 3.50" ceramic bead insulated leads, #8-10 spade terminals, and a one-piece spring clip for mounting.

Wattage	Voltage	Color	Watt Density*		Heater Body Temp.**		Part Number	
			(W/in ²)	(W/cm ²)	(Typical Operating) °F	(Typical Operating) °C	Without Thermocouple	With Type K Thermocouple
250	220/240	Rose to Grey	10.84	1.68	757	403	CRH10029	CRH10030
250	220/240	White	10.84	1.68	757	403	CRH00029	CRH00030
400	220/240	Rose to Grey	17.34	2.69	943	506	CRH10018	CRH10005
400	220/240	White	17.34	2.69	943	506	CRH00018	CRH00005
600	220/240	Rose to Grey	26.01	4.03	1117	603	CRH10010	CRH10011
600	220/240	White	26.01	4.03	1117	603	CRH00010	CRH00011
800	220/240	Rose to Grey	34.68	5.38	1286	697	CRH10001	CRH10019
800	220/240	White	34.68	5.38	1286	697	CRH00001	CRH00019

Series CRD E-Mitters – Size: 122 mm (4.80") square



Color shown is rose (cold) to grey (hot)

Optional Features

- * Additional Power or Thermocouple Lead Lengths (page 7-23)
- * Two-Piece Wave Mounting Clip (page 7-14)
- * Reflectors and Other Accessories (pages 7-20 through 7-23)
- * Arrays and Power/Temperature Control Panels (start on page 7-15)

Standard (Non-Stock) CRD E-Mitters

E-Mitters listed have 3.50" ceramic bead insulated leads, #8-10 spade terminals, and a one-piece spring clip for mounting.

Wattage	Voltage	Color	Watt Density*		Heater Body Temp.**		Part Number	
			(W/in ²)	(W/cm ²)	(Typical Operating) °F	(Typical Operating) °C	Without Thermocouple	With Type K Thermocouple
250	220/240	Rose to Grey	10.84	1.68	757	403	CRD10001	CRD10005
250	220/240	White	10.84	1.68	757	403	CRD00001	CRD00005
400	220/240	Rose to Grey	17.34	2.69	943	506	CRD10002	CRD10006
400	220/240	White	17.34	2.69	943	506	CRD00002	CRD00006
650	220/240	Rose to Grey	28.18	4.37	1158	626	CRD10004	CRD10008
650	220/240	White	28.18	4.37	1158	626	CRD00004	CRD00008

* **Watt density** calculated using heater face surface area.

** **E-Mitter heater body temperature** as measured with internal thermocouple when mounted facedown in stock CRK reflector and operating in 72°F (22°C) room ambient.

Ordering Information

Standard Heaters

Order by Part Number for Standard (Non-Stock) heaters.

Custom Engineered/Manufactured Heaters

Understanding that an electric heater can be very application specific, for sizes and ratings not listed, **TEMPCO** can manufacture a CRH or CRD E-Mitter to meet your requirements. **Standard lead time is 3 weeks.**

Please Specify the following:

- Size:** CRH or CRD
- Colors:** Standard are metamorphing rose and straight white, optional are metamorphing yellow and straight black
- Wattage:** Up to 35w/in² (5.4w/cm²)
- Voltage:** 120, 208, 240, 277, 480 and others (dependent on design)
- Thermocouple:** Standard Type K or optional Type J
- Additional Options:** Start on page 7-20
- Description of Process & Temperature**

⚠ WARNING: Cancer and Reproductive Harm - www.P65Warnings.ca.gov.

(800) 323-6859 • Email: sales@tempco.com

Insulated Flat Face Short Neck Series CRN and CRZ Ceramic E-Mitters

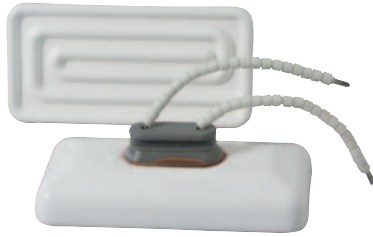
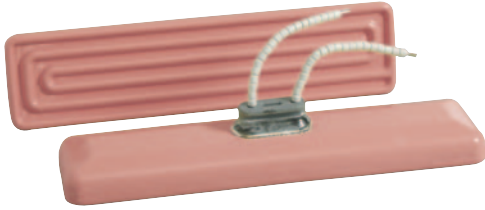

Design Features

- * Universal mount designed to be dropped into existing systems regardless of manufacturer.
- * Standard colors are metamorphing rose (cold) to grey (hot), and traditional white. Optional colors are metamorphing yellow (cold) to orange (hot), and black.
- * Standard stocked voltage: 120 or 220/240V as noted; other voltages are available.
- * Available with built-in type K thermocouple. Optional type J thermocouple is also available.
- * Long operating life—over 10,000-plus hours of continuous operation under normal conditions
- * Performance is unaffected under adverse atmospheric conditions.
- * 2.5 to 6 μ m infrared radiation wavelength

Series CRN Dimensions

Series CRZ Dimensions

Slot size for ceramic mounting heads
0.593" X 1.688" obround hole

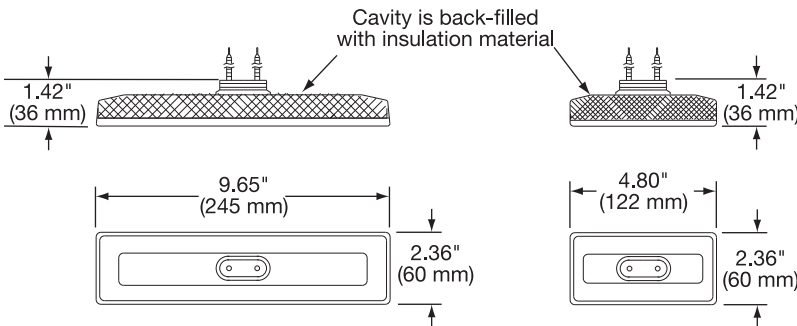

CRN and CRZ E-Mitter Construction

1. **LESS MASS.** A special manufacturing process allows construction with thin walls that withstand larger temperature gradients. The embedded resistance coils heat up the low mass body at a faster rate, providing energy savings.
2. **SUPERIOR INSULATING MATERIAL.** The hollow inner area is filled with low-mass ceramic fiber to further insulate the contact region from the e-mitter surface, resulting in an improved operating life.

Ordering Information

Standard Heaters

Order by Part Number for Standard (Non-Stock) heaters.

Custom Engineered/Manufactured Heaters

Understanding that an electric heater can be very application specific, for sizes and ratings not listed, **TEMPCO** can manufacture a CRN or CRZ E-Mitter to meet your requirements. **Standard lead time is 3 weeks.**

Please Specify the following:

- Size:** CRN or CRZ
- Colors:** Standard are metamorphing rose and straight white, optional are metamorphing yellow and straight black
- Wattage:** Up to 35w/in² (5.4w/cm²)
- Voltage:** 120, 208, 240, 277, 480 and others (dependent on design)
- Thermocouple:** Standard Type K or optional Type J
- Additional Options:** Start on page 7-20

⚠ WARNING: Cancer and Reproductive Harm - www.P65Warnings.ca.gov.



CRN E-Mitters – Size: 60 mm × 245 mm (2.36" × 9.65")

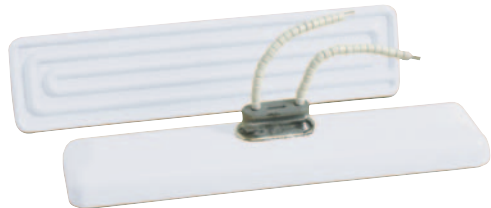

Optional Features

- * *Additional Power or Thermocouple Lead Lengths (page 7-23)*
- * *Two-Piece Wave Mounting Clip (page 7-14)*
- * *Reflectors and Other Accessories (pages 7-20 through 7-23)*
- * *Arrays and Power/Temperature Control Panels (start on page 7-15)*

Standard (Non-Stock) CRN E-Mitters

E-Mitters listed have 3.50" ceramic bead insulated leads, #8-10 spade terminals, and a one-piece spring clip for mounting.

Wattage	Voltage	Color	Watt Density*		Heater Body Temp.**		Part Number	
			(W/in ²)	(W/cm ²)	(Typical Operating) °F	(Typical Operating) °C	Without Thermocouple	With Type K Thermocouple
250	220/240	Rose to Grey	10.97	1.70	762	406	CRN10001	CRN10005
250	220/240	White	10.97	1.70	762	406	CRN00001	CRN00005
400	220/240	Rose to Grey	17.56	2.72	948	509	CRN10002	CRN10006
400	220/240	White	17.56	2.72	948	509	CRN00002	CRN00006
600	220/240	Rose to Grey	26.33	4.08	1123	606	CRN10003	CRN10007
600	220/240	White	26.33	4.08	1123	606	CRN00003	CRN00007
800	220/240	Rose to Grey	35.11	5.44	1294	701	CRN10004	CRN10008
800	220/240	White	35.11	5.44	1294	701	CRN00004	CRN00008

CRZ E-Mitters – Size: 60 mm × 122 mm (2.36" × 4.80")

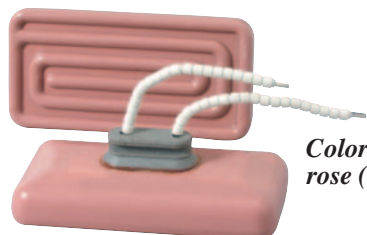

Color shown is rose (cold) to grey (hot)

Optional Features

- * *Additional Power or Thermocouple Lead Lengths (page 7-23)*
- * *Two-Piece Wave Mounting Clip (page 7-14)*
- * *Reflectors and Other Accessories (pages 7-20 through 7-23)*
- * *Arrays and Power/Temperature Control Panels (start on page 7-15)*

Standard (Non-Stock) CRZ E-Mitters

E-Mitters listed have 3.50" ceramic bead insulated leads, #8-10 spade terminals, and a one-piece spring clip for mounting.

Wattage	Voltage	Color	Watt Density*		Heater Body Temp.**		Part Number	
			(W/in ²)	(W/cm ²)	(Typical Operating) °F	(Typical Operating) °C	Without Thermocouple	With Type K Thermocouple
125	220/240	Rose to Grey	10.93	1.69	761	405	CRZ10001	CRZ10005
125	220/240	White	10.93	1.69	761	405	CRZ00001	CRZ00005
200	220/240	Rose to Grey	17.48	2.71	947	508	CRZ10002	CRZ10006
200	220/240	White	17.48	2.71	947	508	CRZ00002	CRZ00006
300	220/240	Rose to Grey	26.23	4.07	1121	605	CRZ10003	CRZ10007
300	220/240	White	26.23	4.07	1121	605	CRZ00003	CRZ00007
400	220/240	Rose to Grey	34.97	5.42	1291	699	CRZ10004	CRZ10008
400	220/240	White	34.97	5.42	1291	699	CRZ00004	CRZ00008
400	480	White	34.97	5.42	1291	699	CRZ00013	CRZ00014

* **Watt density** calculated using heater face surface area.

** **E-Mitter heater body temperature** as measured with internal thermocouple when mounted facedown in stock CRK reflector and operating in 72°F (22°C) room ambient.

Mounting Accessories and Low Noise Thermocouple Option

One-Piece Mounting Clip (Standard)

Designed for heater mounting with 22 ga (.028") to 20 ga (.037") sheet metal.

Part Number SPR-103-102

Thinner or thicker materials require the Two-Piece Mounting Clip.



Standard mounting spring clip shipped with heaters



Two-Piece Wave Mounting Clip (Optional)

The two-piece wave spring clip and holding clip assembly is used for mounting heaters in materials thicker than 20 ga (.037") or thinner than 22 ga (.028")

Part Number: CRK00008

All Items Available from Stock

Single Element Mounting Bracket

A convenient method for mounting individual E-Mitters to a flat surface or panel for spot heating applications

Part Number: CRK00018

The picture shows how the single element mounting bracket can be used to develop a panel array using Series CRB or CRC Ceramic E-Mitters or others with the same mounting head design.

High Temperature Ceramic Terminal Blocks (Part Number EHD-108-101) are used to connect power to the heater leads and can also be used for making thermocouple connections.

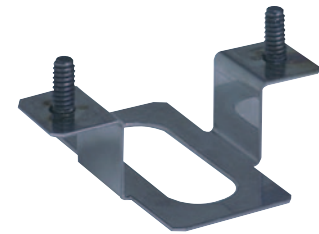
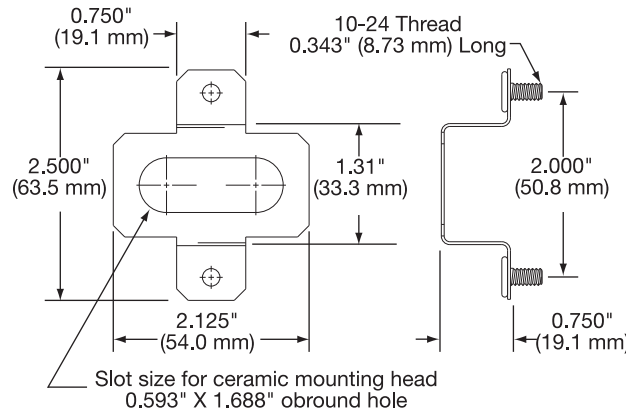
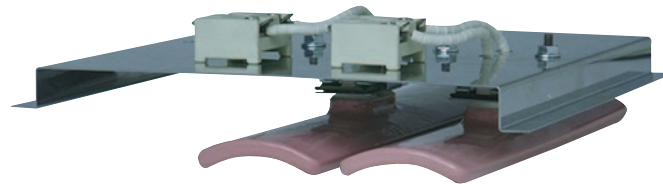

Part Number: CRK00018



Low Noise Thermocouple Option

Generally the standard thermocouple is acceptable for the majority of applications. Most instrumentation inputs have noise rejection sufficient to filter out unwanted 60 hz AC noise that the thermocouple picks up from being mounted close to the coil element for ideal temperature sensing.

For those applications where emf generated noise is a problem for the instrument, Tempco offers a low noise thermocouple solution. The low noise thermocouple option is designed to minimize the induced AC noise by using stainless steel overbraid on the high temperature fiberglass color-coded 24 GA solid leads as a ground shield and a ceramic insulator at the thermocouple junction.

Designed for use in the CRB, CRC, CRL, CRG and CRM solid curved and flat face style heaters. Low noise thermocouples can only be factory installed and must be specified at time of ordering.

Thermocouple Type	Termination	Lead Length (in)
K	Straight Pigtails	8
K	Straight Pigtails	12
K	Straight Pigtails	24
K	Straight Pigtails	48
J	Straight Pigtails	12
J	Straight Pigtails	48

Infrared Radiant Heating Array Systems

Modular Components Simplify Construction of Large Infrared Heating Systems

CRA Linear Array for Ceramic E-Mitters (page 7-16)

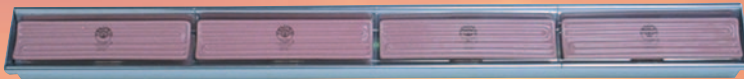

CRA Linear Array for KTE and KTG E-Mitters (page 7-47)



QRH Quartz — Universal 2000 Housing (page 7-56)



CRA Linear Array for Gemini Medium Wave (page 7-68)



KRH Quartz — Universal 2000 Housing (page 7-72)



Series TRH — Tubular Element in Universal 2000 Housing (page 7-74)



Type ARA Array for Ceramic E-Mitters (page 7-28)



Type ARV Array for KTE & KTG E-Mitters (page 7-48)



Type ARG Gemini Medium Wave Arrays (page 7-69)



Type ARK Quartz Tube Arrays (page 7-70)



Type ARC Channel Strip Heater Arrays (page 8-10)



Type ART Tubular Heater Arrays (page 10-17)



TEMPCO will design & manufacture a panel array system, including a power and temperature control panel that meets your needs.

Radiant Process Heaters



CRA Linear Housings

CRA Linear Heater Assemblies



Design Features

- * 220/240V CRB or CRC E-Mitters
- * Extruded aluminum housing
- * E-Mitters pre-wired to terminal blocks
- * METAMORPHING Rose to Grey colored E-Mitters
- * Reflectors
- * Fully assembled, ready to install, with mounting hardware
- * 1/2" trade size wiring entrance at both ends
- * 40" 1000 Watt CRA10025 shown above

Standard (Non-Stock) and Stock Sizes and Electrical Ratings

Assemblies with a Thermocouple have One E-Mitter with a Built-In Type K Thermocouple.

Stock Items Are Shown In RED

Nominal Housing Length	Total Assembly Wattage	E-Mitter Wattage	Number of E-Mitters	Part Number Assembly with no T/C	Part Number Assembly with K T/C	Replacement E-Mitters with no T/C	Replacement E-Mitters with K T/C
10"	250	250	1	CRA10001	CRA10048	CRB10006	CRB10008
	400	400	1	CRA10002	CRA10049	CRB10014	CRB10016
	650	650	1	CRA10003	CRA10050	CRB10023	CRB10025
	1000	1000	1	CRA10004	CRA10051	CRB10031	CRB10033
	250	125	2	CRA10005	CRA10052	CRC10005	CRC10007
	400	200	2	CRA10006	CRA10053	CRC10013	CRC10015
	650	325	2	CRA10007	CRA10054	CRC10021	CRC10023
	1000	500	2	CRA10008	CRA10055	CRC10027	CRC10029
20"	500	250	2	CRA10009	CRA10056	CRB10006	CRB10008
	800	400	2	CRA10010	CRA10057	CRB10014	CRB10016
	1300	650	2	CRA10011	CRA10058	CRB10023	CRB10025
	2000	1000	2	CRA10012	CRA10059	CRB10031	CRB10033
	500	125	4	CRA10013	CRA10060	CRC10005	CRC10007
	800	200	4	CRA10014	CRA10061	CRC10013	CRC10015
	1300	325	4	CRA10015	CRA10062	CRC10021	CRC10023
	2000	500	4	CRA10016	CRA10063	CRC10027	CRC10029
30"	750	250	3	CRA10017	CRA10064	CRB10006	CRB10008
	1200	400	3	CRA10018	CRA10065	CRB10014	CRB10016
	1950	650	3	CRA10019	CRA10066	CRB10023	CRB10025
	3000	1000	3	CRA10020	CRA10046	CRB10031	CRB10033
	750	125	6	CRA10021	CRA10067	CRC10005	CRC10007
	1200	200	6	CRA10022	CRA10068	CRC10013	CRC10015
	1950	325	6	CRA10023	CRA10069	CRC10021	CRC10023
	3000	500	6	CRA10024	CRA10070	CRC10027	CRC10029
40"	1000	250	4	CRA10025	CRA10071	CRB10006	CRB10008
	1600	400	4	CRA10026	CRA10072	CRB10014	CRB10016
	2600	650	4	CRA10027	CRA10073	CRB10023	CRB10025
	4000	1000	4	CRA10028	CRA10047	CRB10031	CRB10033
	1000	125	8	CRA10029	CRA10074	CRC10005	CRC10007
	1600	200	8	CRA10030	CRA10075	CRC10013	CRC10015
	2600	325	8	CRA10031	CRA10076	CRC10021	CRC10023
	4000	500	8	CRA10032	CRA10077	CRC10027	CRC10029
50"	1250	250	5	CRA10131	CRA10118	CRB10006	CRB10008
	2000	400	5	CRA10255	CRA10301	CRB10014	CRB10016
	3250	650	5	CRA10226	CRA10103	CRB10023	CRB10025
	5000	1000	5	CRA10152	CRA10302	CRB10031	CRB10033



DANGER: Hazard of Fire. These heaters are not for use in atmospheres where flammable vapors, gases or liquids are present as defined in the National Electrical Code. Where solvents, water, etc. are being evaporated from the process it is necessary to provide substantial quantities of ventilating air to carry away all resulting vapors.

WARNING: Hazard of Electric Shock. Installation must be grounded to earth to avoid shock hazard. Disconnect power to installation before servicing or installing heater.

WARNING: Do not use Copper Wire to make connections inside this heater. High temperatures will oxidize copper. Use of nickel plated or nickel clad insulated copper wire is recommended. Wire insulation rating must be suitable for the ambient temperature of the wiring installation.

View Product Inventory @ www.tempco.com

CRA Linear Heater Assemblies — Construction

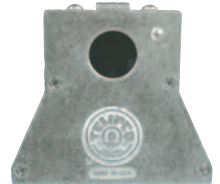
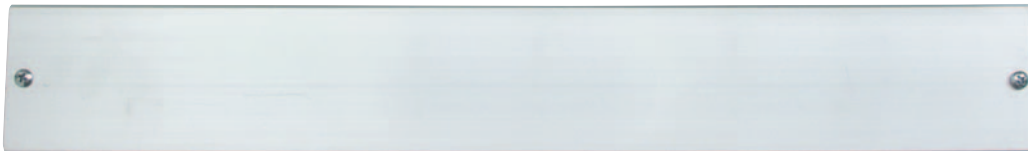

Easiest Replacement of Heaters in the Industry

E-Mitters are easily replaced by removing the top cover. Wiring entrance side covers are not affected. The heater lead wires are insulated with ceramic beads and connected to ceramic terminal blocks. Heaters can be wired to function individually or grouped into heating zones.

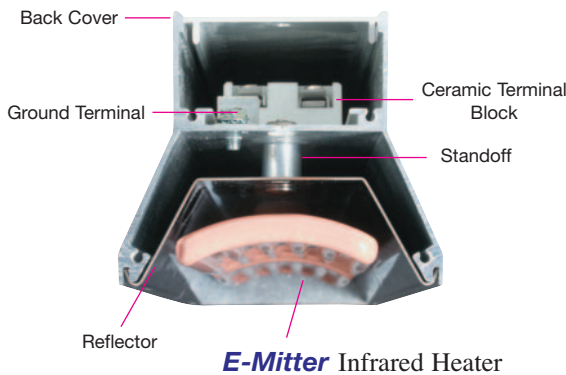

Design Features

- * Designed for use with E-Mitters CRB, CRC, CRN and CRZ
- * Lightweight extruded aluminum housing with 5/16-18 mounting bolts for use up to 250°C (482°F) extrusion temperature
- * E-Mitters are easily replaced by removing the top cover
- * Internal mounting hole pattern simplifies mixing and matching E-Mitter sizes and ratings
- * Space between reflector and housing wall offers a good thermal barrier to protect the wiring area
- * This CRA structural housing can be used with any manufacturer's standard 60 × 245 mm -or- 60 × 122 mm heaters
- * Wiring entrance 7/8" Diameter at both ends, for 1/2" trade size electrical fittings

Wiring Options

Prewired with Plain Leads, Armor Cable or Wire Braid (includes ground wire)

Stainless steel armor cable — 18" armor cable over 24" leads

Galvanized armor cable — 18" armor cable over 24" leads

Stainless steel wire braid — 18" wire braid over 24" leads

Fiberglass leads (450°C rating) — 12" long plain leads

If longer leads and/or longer armor cable are required, specify when ordering.

Prewired with 24" SJO Cable (includes ground wire)

- 16 ga. cable (Up to 15 Amps)
- 14 ga. cable (Up to 22 Amps Max.)
- 12 ga. cable (Up to 28 Amps Max.)
- Max. terminal box temperature 194°F (90°C)
- If longer cable is required, specify when ordering.

Stock Heavy Duty Quick Disconnect Plugs and Connectors

Reference	NEMA P or R	Max. Amps	Volts	Plug Part Number	Connectors (Female) Part Number
P8 straight	6-15	15A	250V	EHD-102-114	EHD-103-139
P3 straight	5-15	15A	125V	EHD-102-103	EHD-103-102
P4 twist lock	L5-15	15A	125V	EHD-102-113	EHD-103-104
P5 twist lock	L6-15	15A	250V	EHD-102-121	EHD-103-107

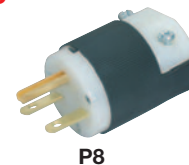

P8



P3



P4

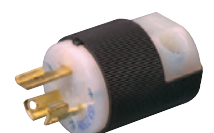

P5



Optional Electrical Plugs listed can be attached to armor cable, HPN cord or plain leads described under wiring Options. Connectors listed are cable mount matching units for the plugs listed and are ordered separately. See page 15-15 for additional plugs and connectors.

Custom CRA Linear Heater Assemblies Using Standard Components

Do It Yourself or let Tempco build an array to your exact specifications using standard components.

Consult Tempco for arrays using custom designed components.



Components Required To Build A Custom CRA Linear Heater using Standard Items

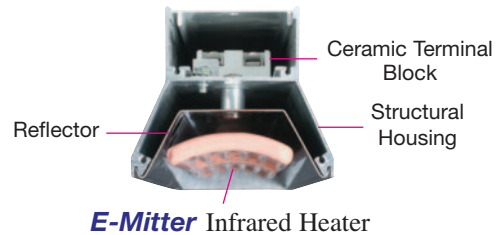

Example

Steps to Design a Custom CRA E-Mitter Linear Assembly from Standard Components

Designing a 40-inch-long CRA assembly using a stock housing length.

Step 1) Select the Housing. This application can use the standard CRK00004 housing from the Standard CRK Housing Lengths Table on page 7-19. Note the Maximum Power Rating of the housing when making your selection.

Step 2) Select the E-Mitters Series. The CRK Housing Lengths Table gives the various possible E-Mitter configurations that will fit the housing selected. A combination of CRBs and CRCs will be used for this application. CRB E-Mitters were selected for the inside three heaters to limit the number of unheated gaps that would be present if all CRC E-Mitters were used. The middle CRB E-Mitter has a thermocouple for temperature control. The outer two heaters *in this example* are CRC E-Mitters at a different w/in² than the CRBs because the heat required at the edges is not the same as the center. The heater color selected is Metamorphing Rose.

CRB E-Mitters can be found on page 7-4.

CRC E-Mitters can be found on page 7-7.

Step 3) Select the Reflectors. Select E-Mitter Reflectors to match the Style and Quantity of E-Mitters you selected. Three Part Number CRK00007 Reflectors are required for the CRB E-Mitters and Two Part Number CRK00006 Reflectors are required for the CRC E-Mitters. Note: Reflectors are complete with mounting hardware to attach to housing (page 7-20).

Step 4) Select the Terminal Blocks. Select the number of terminal blocks required for wiring. This would typically be one for each heater for the power leads and one for each thermocouple (page 7-21 and 7-22). A total of six terminal Blocks, Part Number EHD-108-101, are required. One for the power leads of each E-Mitter and one for the thermocouple on CRB10033.

CRC10021 CRB10031 CRB10033 (has T/C) CRB10031 CRC10021

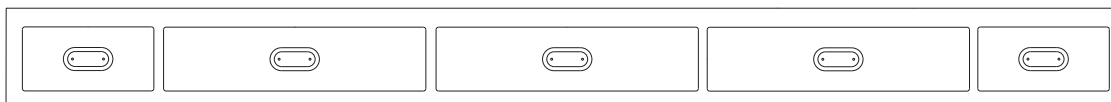

40"

Standard CRK Linear Housings

CRK housings include the following components: housing body, end plates, 5/16-18 mounting bolts, cover and ground lug.

NOTE: These housings do not include the reflectors needed for mounting the heaters (see page 7-20) or the terminal block (Part Number EHD-108-101) required for wiring each heater (see page 7-21).

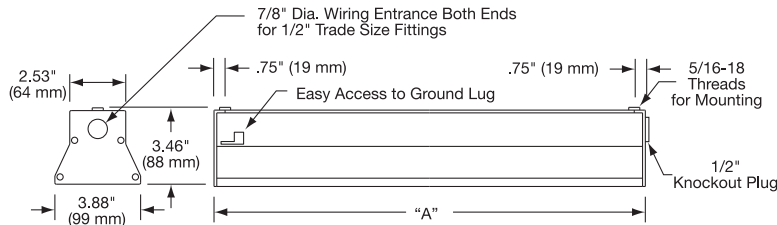

Standard (Non-Stock) Housing Lengths Table

Nominal Housing Length in	"A" Dim. in	"A" Dim. mm	Housing Part Number	Examples of Possible E-Mitter Configurations	Maximum Power
5	5.19	131.8	CRK00024	1 CRC or 1 CRZ	.5KW
10	10.13	257.2	CRK00001	1 CRB or 1 CRN, 2 CRCs or 2 CRZs	1KW
15	15.06	382.6	CRK00023	3 CRCs or 3 CRZs (1 CRB and 1 CRC) or (1 CRN and 1 CRZ)	1.5KW
20	20.00	508.0	CRK00002	2 CRBs or 2 CRNs, 4 CRCs or 4 CRZs (1 CRB and 2 CRCs) or (1 CRN and 2 CRZs)	2KW
25	24.94	633.4	CRK00022	5 CRCs or 5 CRZs a combination of (CRBs and CRCs) or (CRNs and CRZs)	2.5KW
30	29.88	758.8	CRK00003	3 CRBs or 3 CRNs, 6 CRCs or 6 CRZs a combination of (CRBs and CRCs) or (CRNs and CRZs)	3KW
35	34.81	884.2	CRK00019	7 CRCs or 7 CRZs a combination of (CRBs and CRCs) or (CRNs and CRZs)	3.5KW
40	39.75	1009.7	CRK00004	4 CRBs or 4 CRNs, 8 CRCs or 8 CRZs a combination of (CRBs and CRCs) or (CRNs and CRZs)	4KW
50	49.63	1260.5	CRK00021	5 CRBs or 5 CRNs, 10 CRCs or 10 CRZs a combination of (CRBs and CRCs) or (CRNs and CRZs)	5KW
60	59.50	1511.3	CRK00027	6 CRBs or 6 CRNs, 12 CRCs or 12 CRZs a combination of (CRBs and CRCs) or (CRNs and CRZs)	6KW
70	69.38	1762.1	CRK00029	7 CRBs or 7 CRNs, 14 CRCs or 14 CRZs a combination of (CRBs and CRCs) or (CRNs and CRZs)	7KW

Standard housings are available from as-assembled stock in 10", 20", 30", 40" and 50" lengths. Other housing lengths can be made to your requirements.

Ordering Information

Custom Engineered/Manufactured CRA Heater Assembly

Standard Assemblies

Order by Part Number on page 7-16. Delivery is Stock to 3 days.

Understanding that a CRA linear structural housing can be very application specific, **TEMPCO** will design and manufacture a CRA heater assembly to meet your requirements. **Standard lead time is 3 weeks.**

Please Specify the following:

- Housing Length
- E-Mitter Color
- E-Mitter Size, Electrical Ratings or Part Number
- E-Mitter with Built-In Type K T/C, Size, Electrical Ratings or Part Number



If you should encounter any problems or need technical support in the design of the CRA system consult Tempco. Our team of professionals will provide you with the right solution for your application.

WARNING: Cancer and Reproductive Harm - www.P65Warnings.ca.gov.

(800) 323-6859 • Email: sales@tempco.com

Stock Reflectors for CRB, CRN, CRC, CRZ and CRL E-Mitters

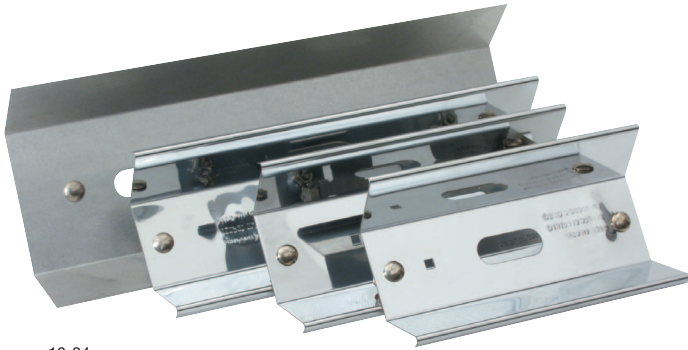

Reflectors for Ceramic E-Mitters

- * Designed to withstand bending and heat distortion.
- * Made from highly polished chrome steel or optional aluminized steel for extreme temperatures and harsh environments.
- * Will withstand high operating temperatures.
- * Available in three standard sizes; includes standoffs and hardware.
- * Easy installation into CRA linear structural housing assemblies (except CRK00032).

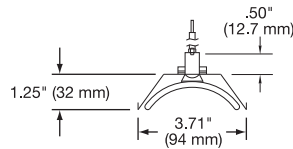
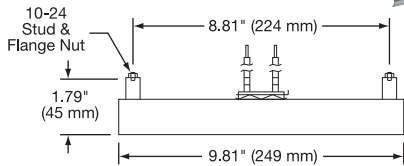

For One CRB E-Mitter or One CRN E-Mitter

Part Number: CRK00007 (Chrome Steel)
Part Number: CRK00049 (Aluminized Steel)

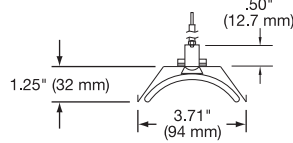
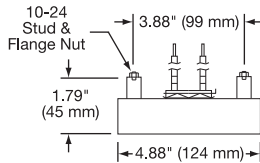

For One CRC E-Mitter or One CRZ E-Mitter

Part Number: CRK00006 (Chrome Steel)
Part Number: CRK00035 (Aluminized Steel)

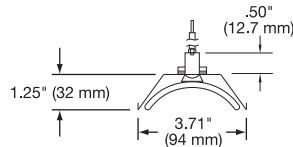
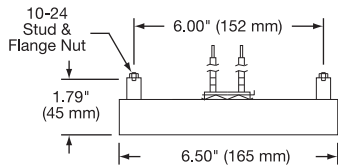

For One CRM E-Mitter

Part Number: CRK00030 (Chrome Steel)
Part Number: CRK00074 (Aluminized Steel)

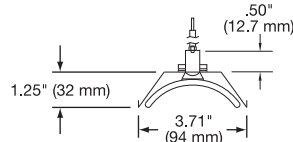
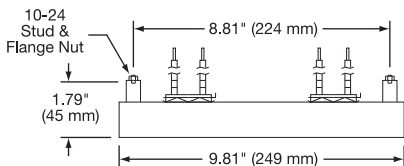

For Two CRC E-Mitters or Two CRZ E-Mitters

Part Number: CRK00020 (Chrome Steel)
Part Number: CRK00043 (Aluminized Steel)

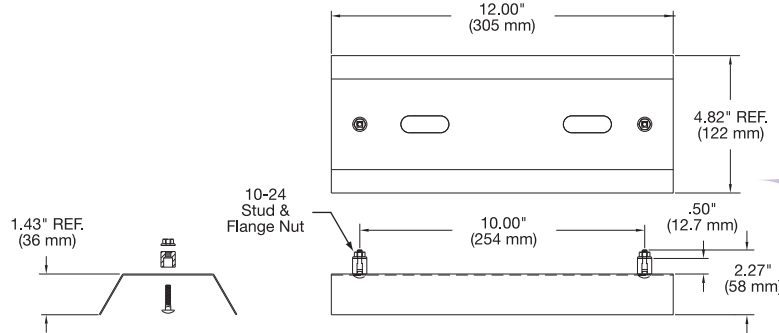

Note: Reflectors in drawings are shown with curved heater(s) for reference only.

For One CRL E-Mitter

Part Number: CRK00032 (Aluminized Steel)

All Items Available from Stock

Ceramic Twist-Loc Wire Connectors

Porcelain Material, Maximum Temperature Rating 1200°F (645°C), 300V Maximum

Agency Approvals: UL and CSA for EHD-114-102, EHD-114-103 and EHD-114-104 (UL File E9809)

Stock Number	MFR Part Number	Wire Range (Solid or Stranded Wire)		Skirt Length	Opening ID	Outer Diameter
EHD-114-102	10-401	2#22	1#18 + 1#16	.687"	.250"	.406"
EHD-114-103	10-405	2#20	2#16	.750"	.312"	.484"
EHD-114-104	10-407	2#18	2#14	.843"	.406"	.531"
EHD-114-105	-	1#16 + 1#14	1#14 + 2#12	1.00"	.468"	.703"





Standard Ceramic Terminal Blocks for Internal Wiring

Used for internal connections within CRA linear structural housings and ARA arrays.

Design Features

- * **Maximum Voltage:** 600 VAC
- * **Maximum Current:** 20 Amps
- * **Maximum Temperature:** 450°C/842°F
- * **AWG:** 20-12 ga. wire
- * **Hardware:** Stainless Steel
- * **Terminals:** #8 Screw
- * **Body Material:** Steatite

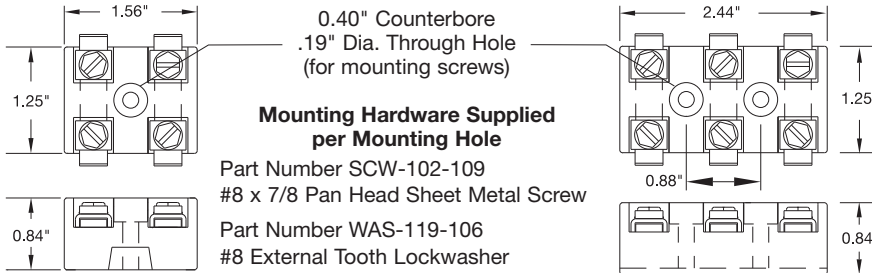

Part Number:
EHD-108-101



Part Number:
EHD-108-121

Ceramic Terminal Blocks (Enclosed Terminals)

Used for wiring of heater power and thermocouple wiring in high temperature locations.

Design Features

- * **Maximum Voltage:** 380 VAC
- * **Maximum Current:** 30 Amps
- * **Maximum Temperature:** 240°C/464°F
- * **AWG:** 26-12 stranded, 26-14 solid
- * **Screw:** M3, zinc plated steel
- * **Terminal Body:** Nickel plated brass
- * **Body Material:** Porcelain
- * **Rating:** CE, VDE



Part Number:
EHD-108-116



Part Number:
EHD-108-117



Part Number:
EHD-108-118

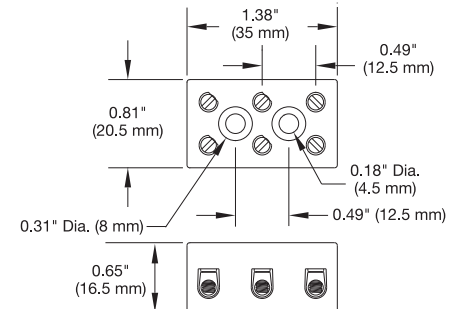
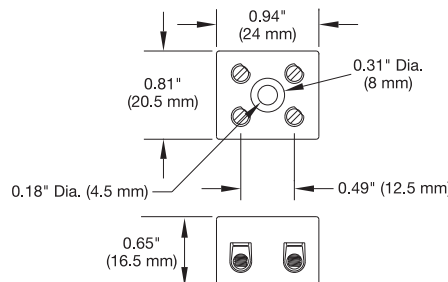
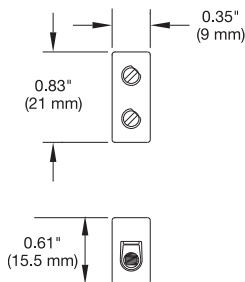

Design Features

- * **Maximum Voltage:** 600 VAC
- * **Maximum Current:** 50 Amps
- * **Maximum Temperature:** 200°C/392°F
- * **AWG:** 14-8 ga wire
- * **Screw:** M4, zinc plated steel
- * **Terminal Body:** Nickel plated brass
- * **Body Material:** Porcelain
- * **Agency Approval:** UL, File # E69841

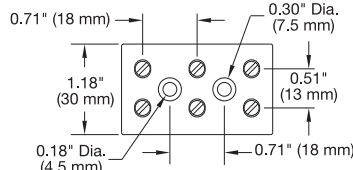
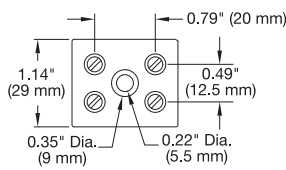

Stock Number: EHD-108-114
MFR Part Number: 4010-B



Stock Number: EHD-108-115
MFR Part Number: 4011-B

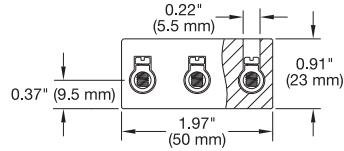
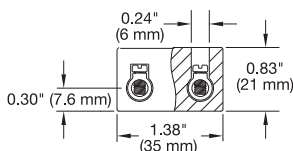

Stock Ceramic Terminal Blocks

Heavy Duty High Temperature Ceramic Line Wiring Blocks (Exposed Terminals)

Used for interfacing heater assemblies, CRA housings and ARA arrays to external line wiring.

Design Features

- * **Maximum Voltage:** 500 VAC
- * **Maximum Current:** 44 Amps @ 104°F ambient
- * **Maximum Temperature:** 240°C/464°F
- * **Wire Gauge:** 18 to 8 ga.
- * **Terminal Screw:** M4, zinc-plated steel
- * **Body Material:** Steatite
- * **Agency Approvals:** None

Optional Terminal Hardware

Stainless Steel Flat Washer — Part Number: WAS-109-101

Spring Lock Washers — Part Number: WAS-118-108

Part Number: EHD-108-106

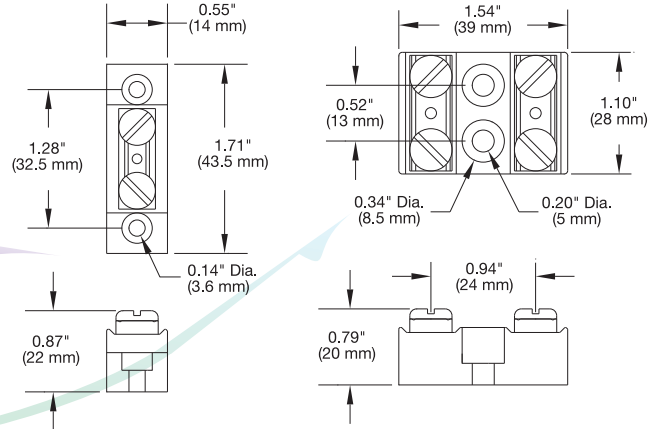

Part Number: EHD-108-107

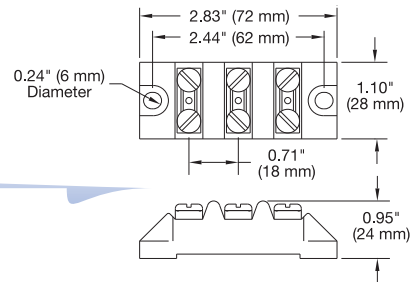

Part Number: EHD-108-108

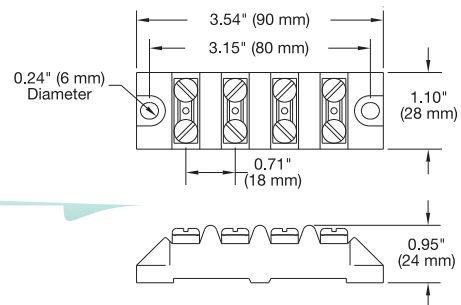

Part Number: EHD-108-109

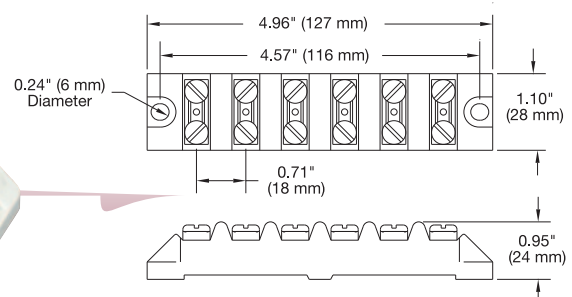

Part Number: EHD-108-105



All Items Available from Stock



Stock Hi-Temp (900°F) Nickel Plated Steel Uninsulated Terminals

The following optional terminals are available for use with Ceramic E-Mitter heaters and for assembly wiring. (Ceramic E-Mitters come standard with Part Number TER-115-112 #8-10 Ni Plated Steel spade terminals.)

Terminal Type	Description	Usage	Part Number
Ring	#10 stud, 22-18 ga. wire	Heater leads	TER-110-117
	#10 stud, 16-14 ga. wire	Misc.	TER-110-106
	#10 stud, 16-14 ga. wire	Misc. (Monel material)	TER-110-104
	#10 stud, 12-10 ga. wire	Line Wiring of Assy.	TER-110-111
Ring	#8 stud, 22-18 ga. wire	Heater leads	TER-109-110*
	#8 stud, 16-14 ga. wire	Heater leads	TER-109-104
	#8 stud, 12-10 ga. wire	Line wiring of Assy.	TER-109-106
Spade	#10 stud, 22-18 ga. wire	Misc.	TER-115-111
	#8-10 stud, 22-18 ga. wire	Heater leads (Standard)	TER-115-112*
	#8 stud, 16-14 ga. wire	Internal CRA & ARA wiring	TER-115-113*
Straight	1/4" long Ni 200 Barrel Crimp	T/C or Heater leads	CON-101-101



All Items Available from Stock

* Standard sizes for heater leads to internal ceramic terminal blocks used in CRA housings and radiant arrays. Must be used with EHD-108-101 (2-pole) or EHD-108-121 (3-pole) standard terminal blocks.

Stock High Temperature Stranded Lead Wire

The following insulated lead wires are available for internal bussing and the line input wiring of CRA Linear Housing Assemblies and AR_ Radiant Panels.



Temperature Rating	Size & Conductor	Maximum Amperage	100 Foot Spool	250 Foot Spool	500 Foot Spool	Usage
450°C, 600V	18 ga. NCC	12.3 @ 300°C (572°F)	LDWR-1088	LDWR-1098	LDWR-1142	Heater lead modifications Miscellaneous Standard for internal wiring of factory wired units
450°C, 600V	16 ga. NCC	18.0 @ 300°C (572°F)	LDWR-1089	LDWR-1099	LDWR-1143	
450°C, 600V	14 ga. NCC	21.2 @ 300°C (572°F)	LDWR-1090	LDWR-1100	LDWR-1144	
450°C, 600V	12 ga. NCC	26.2 @ 300°C (572°F)	LDWR-1091	LDWR-1101	LDWR-1145	Panel zones & line input
450°C, 600V	10 ga. NCC	35.6 @ 300°C (572°F)	LDWR-1092	LDWR-1102	LDWR-1146	
250°C, 600V	18 ga. NPC	9.0 @ 200°C (392°F)	LDWR-1093	LDWR-1103	LDWR-1147	Heater lead modifications Miscellaneous
250°C, 600V	16 ga. NPC	14.2 @ 200°C (392°F)	LDWR-1094	LDWR-1104	LDWR-1148	
250°C, 600V	14 ga. NPC	21.1 @ 200°C (392°F)	LDWR-1095	LDWR-1105	LDWR-1149	Internal panel wiring Panel zones & line input
250°C, 600V	12 ga. NPC	29.5 @ 200°C (392°F)	LDWR-1096	LDWR-1106	LDWR-1150	
250°C, 600V	10 ga. NPC	37.6 @ 200°C (392°F)	LDWR-1097	LDWR-1107	LDWR-1151	

NCC = Nickel Clad Copper, 27% Nickel by weight. NPC = Nickel Plated Copper, 2% Nickel by weight.

The 450°C (842°F) rated wires amperage is derated over 300°C (572°F). Maximum ambient is 400°C (752°F).

The 250°C (482°F) rated wires amperage is derated over 200°C (392°F). Maximum ambient is 225°C (437°F).

See page 15-2 for additional specifications.

See amperage tables in Engineering Section 16 for more details on current carrying capacity of Tempco's high temperature lead wire. For bare wire consult Tempco, for ceramic beads see page 15-13.

Stock High Temperature Thermocouple Wire

The following insulated thermocouple wires are available for internal bussing and wiring of CRA Linear Housing Assemblies and AR_ Radiant Panels to external control systems.

These duplex thermocouple wires have color coded fiberglass insulation over each lead within an overall fiberglass insulation jacket.



Type	Wire Style	100 Foot Spool	250 Foot Spool
K	20 ga. solid	TCWR-1025	TCWR-1029
K	20 ga. stranded	TCWR-1034	TCWR-1036
J	20 ga. solid	TCWR-1028	TCWR-1032
J	20 ga. stranded	TCWR-1033	TCWR-1035
With Stainless Steel Overbraid			
K	20 ga. stranded	TCWR-1049	TCWR-1053
J	20 ga. stranded	TCWR-1047	TCWR-1051

See page 14-107 and 15-4 for additional thermocouple wire and specifications.

For bare wire and sleeving consult Tempco.

CRP 12" x 12" Modular Panels – METAMORPHING Yellow to Orange

New Cost Effective and Self-Contained Ceramic Infrared Panel Heater Offers Ease of Installation and Trouble-Free Performance



Design Features

- * Standard colors are metamorphing yellow (cold) to orange (hot), and traditional white. Optional colors are metamorphing rose (cold) to grey (hot) and black.
- * Low profile 20 ga. aluminized steel or stainless steel housing.
- * Standard stocked voltage: 120, 220-240V or 480V as noted; other voltages are available.
- * Low noise type K thermocouple mounted internally in center heater. Optional type J thermocouple is also available.
- * Watt density range: from 11w/in² to 35w/in²
- * Standard operating temp range: 750°F to 1300°F
- * Best when used at radiation distances of 4-10" from application.
- * Performance is unaffected by vibration or adverse atmospheric conditions.
- * 3 to 6µm infrared radiation wavelength.
- * Made to order.

*Three CRL E-Mitter heaters in one panel.
See page 7-26 for CRP Modular Panel with
an additional emitting glass face.*

Tabletop Point-of-Use Temperature Control Console Systems

See Section 13, page 13-52

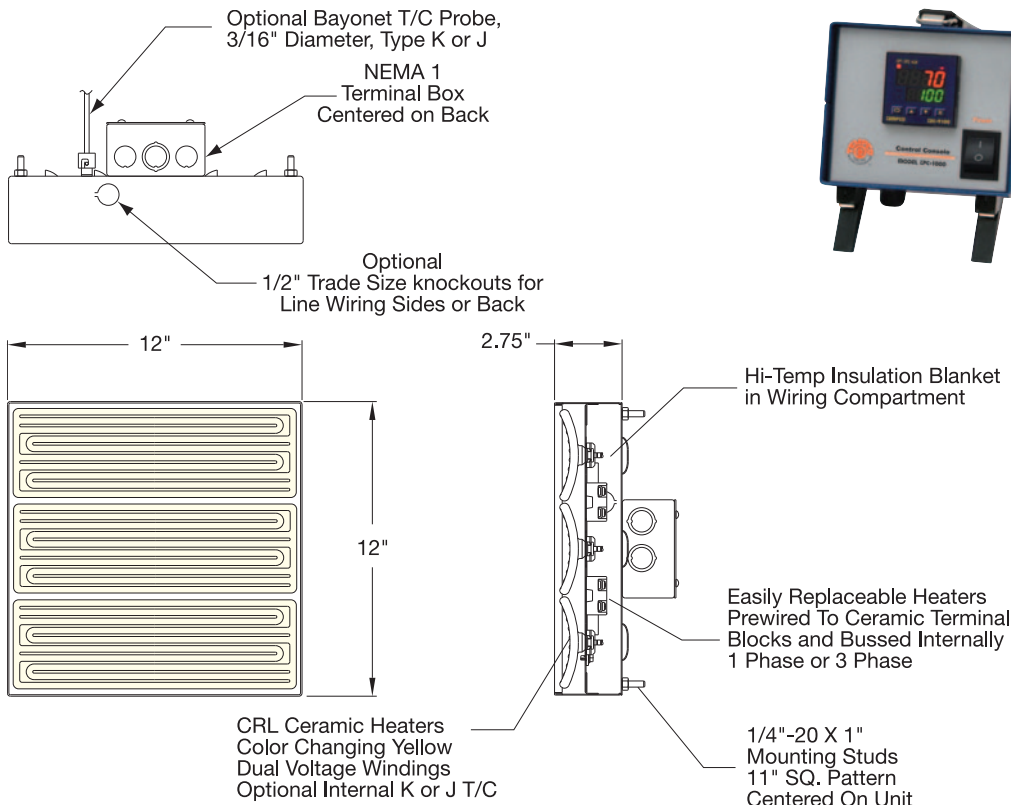



Standard Ratings of Modular 12" x 12" CRP Radiant Panels – METAMORPHING Yellow to Orange

Aluminized Steel Housing with NEMA 1 Terminal Box (4" square by 2-1/8" deep)

KW	Watt Density (W/in ²)	Part Number									
		120V		240V-1Ph		240V-3Ph		480V-1Ph		480V-3Ph	
		No T/C	K T/C	No T/C	K T/C	No T/C	K T/C	No T/C	K T/C	No T/C	K T/C
1.50	11.6	CRP20001	CRP20002	CRP20003	CRP20004	CRP20005	CRP20006	CRP20007	CRP20008	CRP20009	CRP20010
2.25	17.4	CRP20011	CRP20012	CRP20013	CRP20014	CRP20015	CRP20016	CRP20017	CRP20018	CRP20019	CRP20020
3.00	23.0	—	—	CRP20021	CRP20022	CRP20023	CRP20024	CRP20025	CRP20026	CRP20027	CRP20028
3.75	29.0	—	—	CRP20029	CRP20030	CRP20031	CRP20032	CRP20033	CRP20034	CRP20035	CRP20036
4.50	35.0	—	—	CRP20037	CRP20038	CRP20039	CRP20040	CRP20041	CRP20042	CRP20043	CRP20044

NOTE: K T/C panels have one low noise internal T/C in center heater with extension wires routed into rear terminal box.

Stainless Steel Housing with NEMA 1 Terminal Box (Medical or Food Applications)

KW	Watt Density (W/in ²)	Part Number									
		120V		240V-1Ph		240V-3Ph		480V-1Ph		480V-3Ph	
		No T/C	K T/C	No T/C	K T/C	No T/C	K T/C	No T/C	K T/C	No T/C	K T/C
1.50	11.6	CRP20045	CRP20046	CRP20047	CRP20048	CRP20049	CRP20050	CRP20051	CRP20052	CRP20053	CRP20054
2.25	17.4	CRP20055	CRP20056	CRP20057	CRP20058	CRP20059	CRP20060	CRP20061	CRP20062	CRP20063	CRP20064
3.00	23.0	—	—	CRP20065	CRP20066	CRP20067	CRP20068	CRP20069	CRP20070	CRP20071	CRP20072
3.75	29.0	—	—	CRP20073	CRP20074	CRP20075	CRP20076	CRP20077	CRP20078	CRP20079	CRP20080
4.50	35.0	—	—	CRP20081	CRP20082	CRP20083	CRP20084	CRP20085	CRP20086	CRP20087	CRP20088

NOTE: K T/C panels have one low noise internal T/C in center heater with extension wires routed into rear terminal box.

Replacement Heaters for Standard Modular 12" x 12" CRP Radiant Panels

Panel KW	Heater Watts	Part Number					
		120V		120V-240V		240V-480V	
		No T/C	K T/C	No T/C	K T/C	No T/C	K T/C
1.50	500	CRL20021	CRL20022			CRL20023	CRL20024
2.25	750	—	—	CRL20025	CRL20026	CRL20027	CRL20028
3.00	1000	—	—			CRL20029	CRL20030
3.75	1250	—	—			CRL20031	CRL20032
4.50	1500	—	—			CRL20033	CRL20034

NOTES: All dual voltage heaters have two windings (parallel connected for the lower voltage & series connected for the higher voltage).

120V heaters are single winding designs.

K T/C units have an internal "low noise" style thermocouple with 12" leads.

Standard Panel Specifications

KW	Panel Watt Density***	Typical Operating Temperature**		Primary Emitted Wavelength*
		°F	°C	
1.50	12.0	796	424	4.2
2.25	18.0	956	513	3.7
3.00	24.0	1076	580	3.4
3.75	30.0	1191	644	3.2
4.50	36.0	1308	709	3.0

*Peak infrared radiation wavelength as calculated from Wien's Law, for operating temperature shown. Expressed in microns (μm). Operating temperature based on room ambient testing @ 72°F.

**E-Mitter heater body temperature as measured with internal thermocouple when mounted facedown in stock CRK reflector and operating in 72°F/22°C room ambient.

***Watt density calculated using total heater face surface area within panel.

DANGER: Hazard of Fire. These heaters are not for use in atmospheres where flammable vapors, gases or liquids are present as defined in the National Electrical Code. Where solvents, water, etc. are being evaporated from the process it is necessary to provide substantial quantities of ventilating air to carry away all resulting vapors.



WARNING: Hazard of Electric Shock. Installation must be grounded to earth to avoid shock hazard. Disconnect power to installation before servicing or installing heater.

WARNING: Do not use Copper Wire to make connections inside this heater. High temperatures will oxidize copper. Use of nickel plated or nickel clad insulated copper wire is recommended. Wire insulation rating must be suitable for the ambient temperature of the wiring installation.

Installation: Do not mount CRP Panel Heaters closer than 6 inches to any structural material that does not have at least a 200°C (392°F) continuous temperature rating.

CONTINUED →

(800) 323-6859 • Email: sales@tempco.com

CRP 12" x 12" Modular Glass Face Panels Standard Ratings



Three CRL E-Mitter heaters behind an emitting dark red glass face

Design Features

- * Dark red face glass is standard. Glass provides for ease of cleaning.
- * Low profile 20 gauge aluminized steel or stainless steel housing
- * Standard stocked voltage: 120, 220-240V or 480V as noted; other voltages are available.
- * Low noise type K thermocouple mounted internally in center heater. Optional type J thermocouple is also available.
- * Watt density range: from 11w/in² to 35w/in²
- * Standard operating temp range: 750°F to 1300°F
- * Best when used at radiation distances of 4-10" from application.
- * Performance is unaffected by vibration or adverse atmospheric conditions.
- * 3 to 6µm infrared radiation wavelength.
- * Optional clear face glass is available. If required, please specify when ordering.
- * Made to order.

Tabletop Point-of-Use Temperature Control Console Systems

See Section 13, page 13-52

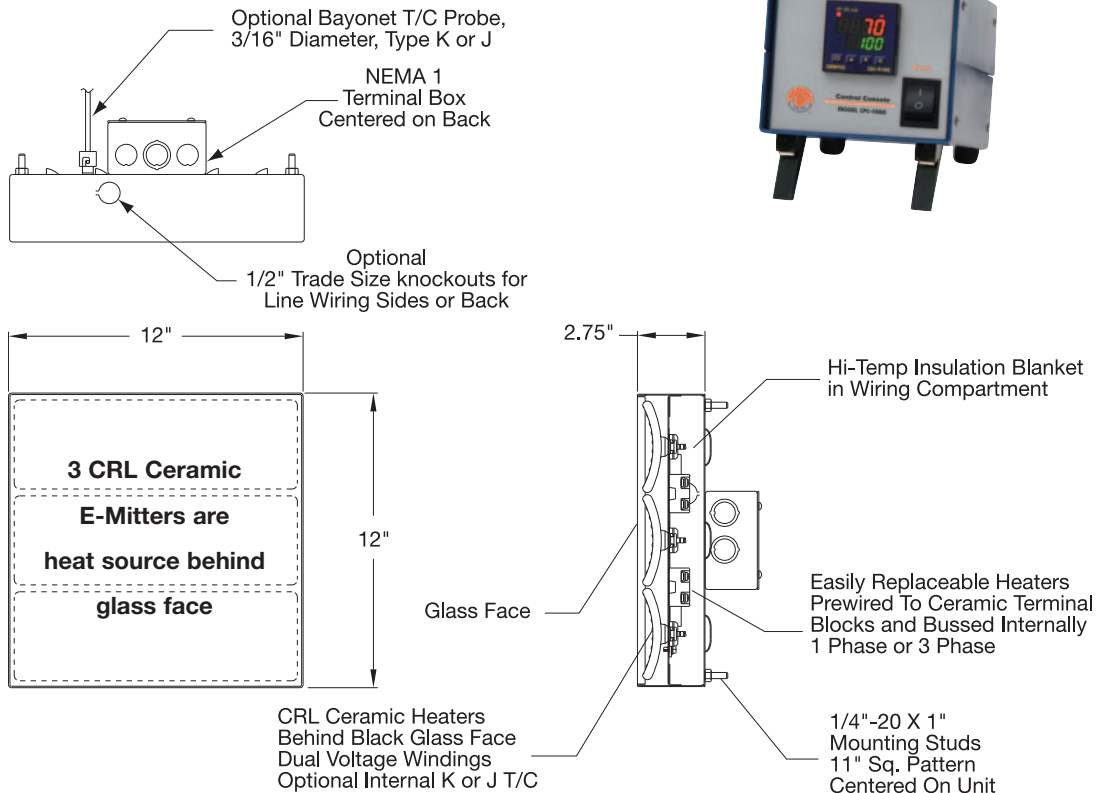



Standard Ratings of Modular 12" x 12" CRP Glass Faced Radiant Panels

Aluminized Steel Housing with NEMA 1 Terminal Box (4" square by 2.13" deep)

KW	Watt Density (W/in ²)	Part Number									
		120V		240V-1Ph		240V-3Ph		480V-1Ph		480V-3Ph	
		No T/C	K T/C	No T/C	K T/C	No T/C	K T/C	No T/C	K T/C	No T/C	K T/C
1.50	11.6	CRP20089	CRP20090	CRP20091	CRP20092	CRP20093	CRP20094	CRP20095	CRP20096	CRP20097	CRP20098
2.25	17.4	CRP20099	CRP20100	CRP20101	CRP20102	CRP20103	CRP20104	CRP20105	CRP20106	CRP20107	CRP20108
3.00	23.0	—	—	CRP20109	CRP20110	CRP20111	CRP20112	CRP20113	CRP20114	CRP20115	CRP20116
3.75	29.0	—	—	CRP20117	CRP20118	CRP20119	CRP20120	CRP20121	CRP20122	CRP20123	CRP20124
4.50	35.0	—	—	CRP20125	CRP20126	CRP20127	CRP20128	CRP20129	CRP20130	CRP20131	CRP20132

NOTE: K T/C panels have one low noise internal T/C in center heater with extension wires routed into rear terminal box.

Stainless Steel Housing with NEMA 1 Terminal Box (4" square by 2.13" deep)

KW	Watt Density (W/in ²)	Part Number									
		120V		240V-1Ph		240V-3Ph		480V-1Ph		480V-3Ph	
		No T/C	K T/C	No T/C	K T/C	No T/C	K T/C	No T/C	K T/C	No T/C	K T/C
1.50	11.6	CRP20133	CRP20134	CRP20135	CRP20136	CRP20137	CRP20138	CRP20139	CRP20140	CRP20141	CRP20142
2.25	17.4	CRP20143	CRP20144	CRP20145	CRP20146	CRP20147	CRP20148	CRP20149	CRP20150	CRP20151	CRP20152
3.00	23.0	—	—	CRP20153	CRP20154	CRP20155	CRP20156	CRP20157	CRP20158	CRP20159	CRP20160
3.75	29.0	—	—	CRP20161	CRP20162	CRP20163	CRP20164	CRP20165	CRP20166	CRP20167	CRP20168
4.50	35.0	—	—	CRP20169	CRP20170	CRP20171	CRP20172	CRP20173	CRP20174	CRP20175	CRP20176

NOTE: K T/C panels have one low noise internal T/C in center heater with extension wires routed into rear terminal box.

Replacement Heaters for Standard Modular 12" x 12" CRP Radiant Panels

Panel KW	Heater Watts	Part Number			
		120V		240V-480V	
		No T/C	K T/C	No T/C	K T/C
1.50	500	CRL20021	CRL20022	CRL20023	CRL20024
2.25	750	CRL20025	CRL20026	CRL20027	CRL20028
3.00	1000	—	—	CRL20029	CRL20030
3.75	1250	—	—	CRL20031	CRL20032
4.50	1500	—	—	CRL20033	CRL20034

NOTE: All 240/480V heaters have two windings for dual voltage use (Parallel connected for 240V & series connected for 480V)
 120V heaters are single winding designs.
 K T/C units have an internal "low noise" style thermocouple with 12" leads.

CRP Replacement Glass

Color	Part Number
Dark Red	GLS-101-101
Clear	GLS-101-102

DANGER: Hazard of Fire. These heaters are not for use in atmospheres where flammable vapors, gases or liquids are present as defined in the National Electrical Code. Where solvents, water, etc. are being evaporated from the process it is necessary to provide substantial quantities of ventilating air to carry away all resulting vapors.



WARNING: Hazard of Electric Shock. Installation must be grounded to earth to avoid shock hazard. Disconnect power to installation before servicing or installing heater.

WARNING: Do not use Copper Wire to make connections inside this heater. High temperatures will oxidize copper. Use of nickel plated or nickel clad insulated copper wire is recommended. Wire insulation rating must be suitable for the ambient temperature of the wiring installation.

Installation: Do not mount CRP Panel Heaters closer than 6 inches to any structural material that does not have at least a 200°C (392°F) continuous temperature rating.

ARA Single Panel Arrays

ARA Array Assemblies for CRB, CRN, CRM, CRC, CRZ, CRL, CRH and CRG E-Mitters®

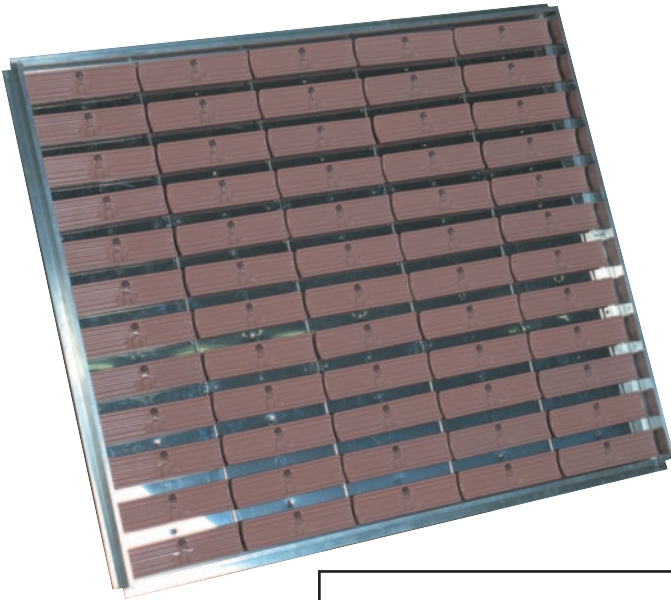

Design Features

- * Custom Engineered/Manufactured
- * Lightweight extruded aluminum outer housing
- * Each heater's power leads are connected to an individual ceramic terminal block
- * NCC or Nickel wire with heat resistant insulation is used for wiring between terminal blocks (see pages 7-21 through 7-23)
- * Zones with different radiant heat levels can be achieved by using different wattage heaters (each zone would have a heater with built-in thermocouple for temperature control)
- * Shipped fully assembled
- * Optional factory wiring and power control panels
- * Optional ceramic fiber insulation in wiring space
- * Optional entrances in rear cover or sides to customer specs

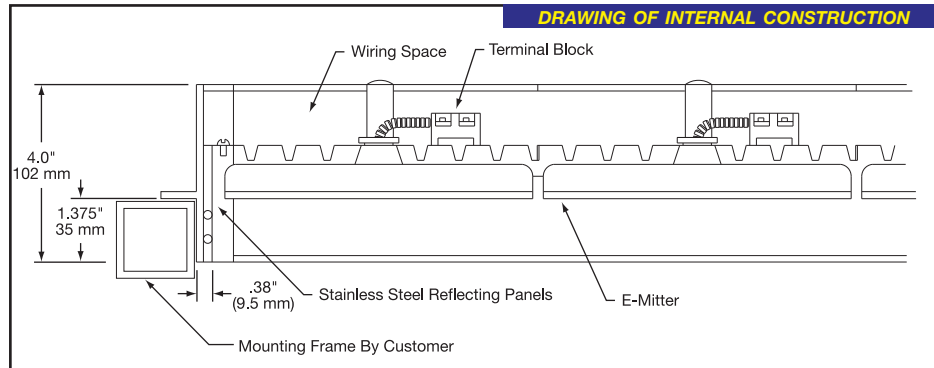

Steps to Design a Custom ARA E-Mitter Array for your application

- 1.) Select a panel array size for the Style E-Mitter:
CRB and CRN E-Mitter panel sizes can be found on page 7-29.
CRM E-Mitter panel size can be found on page 7-30.
CRC and CRZ E-Mitter panel sizes can be found on page 7-31.
CRL E-Mitter panel sizes can be found on page 7-32.
CRH and CRG E-Mitter panel sizes can be found on page 7-33.
CRD E-Mitter panel sizes can be found on page 7-35.
- 2.) Determine any special heat zoning.
- 3.) Specify any E-Mitters that will have thermocouples.

*There is
No Substitute
for Our Experience*

**SATISFACTION
GUARANTEED!**

Ordering Information

Refer to the worksheet on page 7-36



DANGER: Hazard of Fire. These heaters are not for use in atmospheres where flammable vapors, gases or liquids are present as defined in the National Electrical Code. Where solvents, water, etc. are being evaporated from the process it is necessary to provide substantial quantities of ventilating air to carry away all resulting vapors.

Do not mount heater closer than 6 inches to any structural material that does not have at least a 200°C continuous temperature rating.

WARNING: Hazard of Electric Shock. Installation must be grounded to earth to avoid shock hazard. Disconnect power to installation before servicing or installing heater.

Series CRB and CRN E-Mitter Panel Arrays Standard Style ARA Structural Housing Dimensions

- A) The Number of Rows will determine the Housing Width. For overall width add 1.50" (for the mounting lips).
 B) The Number of Columns will determine the Housing Length. For overall length add 1.50" (for the mounting lips).

Number of Rows	Number of Columns					
	1 W x L	2 W x L	3 W x L	4 W x L	5 W x L	6 W x L
1	4 x 11	4 x 21	4 x 31	4 x 41	4 x 51	4 x 61
2	7 x 11	7 x 21	7 x 31	7 x 41	7 x 51	7 x 61
3	10 x 11	10 x 21	10 x 31	10 x 41	10 x 51	10 x 61
4	13 x 11	13 x 21	13 x 31	13 x 41	13 x 51	13 x 61
5	16 x 11	16 x 21	16 x 31	16 x 41	16 x 51	16 x 61
6	19 x 11	19 x 21	19 x 31	19 x 41	19 x 51	19 x 61
7	22 x 11	22 x 21	22 x 31	22 x 41	22 x 51	22 x 61
8	25 x 11	25 x 21	25 x 31	25 x 41	25 x 51	25 x 61
9	28 x 11	28 x 21	28 x 31	28 x 41	28 x 51	—
10	31 x 11	31 x 21	31 x 31	31 x 41	—	—
11	34 x 11	34 x 21	34 x 31	34 x 41	—	—
12	37 x 11	37 x 21	37 x 31	37 x 41	—	—
13	40 x 11	40 x 21	40 x 31	—	—	—
14	43 x 11	43 x 21	43 x 31	—	—	—
15	46 x 11	46 x 21	46 x 31	—	—	—
16	49 x 11	49 x 21	—	—	—	—
17	52 x 11	52 x 21	—	—	—	—
18	55 x 11	55 x 21	—	—	—	—



Note: Structural Housing Dimensions (width x length) are in inches. For overall dimensions add 0.75" per side for the mounting lip.

Dimensions are in inches

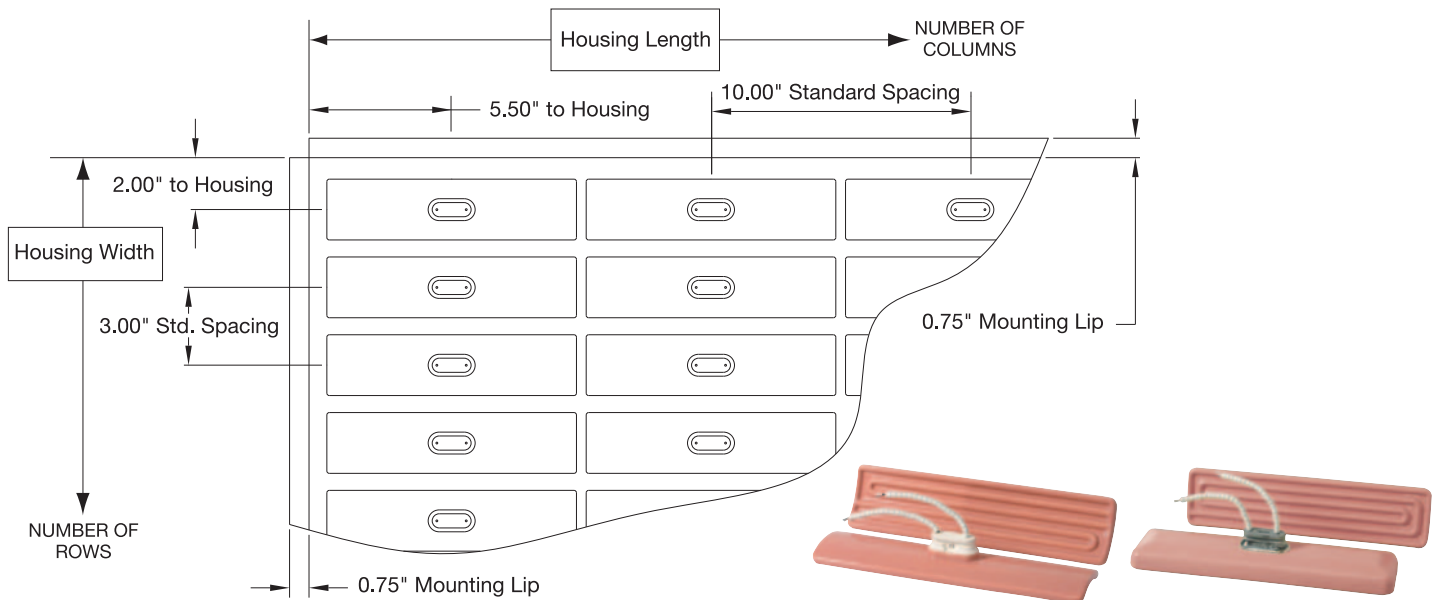

CRB & CRN E-Mitters (60 x 245 mm)

Custom Engineered/Manufactured Panels

- Multiple panels are used for larger arrays.
- Consult factory for larger panels not shown in table or custom panels with other spacings. Minimum spacing for CRB and CRN heaters is 2.50" x 10.00".
- Special narrow panels having a maximum 40 rows x 1 or 2 columns, & up to 8 rows x 12 columns can be made on special order (max. housing size 121" x 25").

We welcome your inquiries.
 Take advantage of Tempco's economical approach to manufacturing panels.

WARNING: Cancer and Reproductive Harm - www.P65Warnings.ca.gov.

(800) 323-6859 • Email: sales@tempco.com

Series CRM E-Mitter Panel Arrays Standard Style ARA Structural Housing Dimensions

- A) The Number of Rows will determine the Housing Width. For overall width add 1.50" (for the mounting lips).
B) The Number of Columns will determine the Housing Length. For overall length add 1.50" (for the mounting lips).

Number of Rows	Number of Columns								
	1 W x L	2 W x L	3 W x L	4 W x L	5 W x L	6 W x L	7 W x L	8 W x L	9 W x L
1	4 x 8	4 x 15	4 x 22	4 x 29	4 x 36	4 x 43	4 x 50	4 x 57	4 x 64
2	7 x 8	7 x 15	7 x 22	7 x 29	7 x 36	7 x 43	7 x 50	7 x 57	7 x 64
3	10 x 8	10 x 15	10 x 22	10 x 29	10 x 36	10 x 43	10 x 50	10 x 57	10 x 64
4	13 x 8	13 x 15	13 x 22	13 x 29	13 x 36	13 x 43	13 x 50	13 x 57	13 x 64
5	16 x 8	16 x 15	16 x 22	16 x 29	16 x 36	16 x 43	16 x 50	16 x 57	16 x 64
6	19 x 8	19 x 15	19 x 22	19 x 29	19 x 36	19 x 43	19 x 50	19 x 57	19 x 64
7	22 x 8	22 x 15	22 x 22	22 x 29	22 x 36	22 x 43	22 x 50	22 x 57	22 x 64
8	25 x 8	25 x 15	25 x 22	25 x 29	25 x 36	25 x 43	25 x 50	25 x 57	25 x 64
9	28 x 8	28 x 15	28 x 22	28 x 29	28 x 36	28 x 43	28 x 50	—	—
10	31 x 8	31 x 15	31 x 22	31 x 29	31 x 36	31 x 43	31 x 50	—	—
11	34 x 8	34 x 15	34 x 22	34 x 29	34 x 36	34 x 43	—	—	—
12	37 x 8	37 x 15	37 x 22	37 x 29	37 x 36	37 x 43	—	—	—
13	40 x 8	40 x 15	40 x 22	40 x 29	40 x 36	—	Dimensions are in inches		
14	43 x 8	43 x 15	43 x 22	43 x 29	—	—			
15	46 x 8	46 x 15	46 x 22	46 x 29	—	—	—	—	—
16	49 x 8	49 x 15	49 x 22	—	—	—	—	—	—
17	52 x 8	52 x 15	52 x 22	—	—	—	—	—	—
18	55 x 8	55 x 15	55 x 22	—	—	—	—	—	—



Note: Structural Housing Dimensions (width x length) are in inches. For overall dimensions add 0.75" per side for the mounting lip.

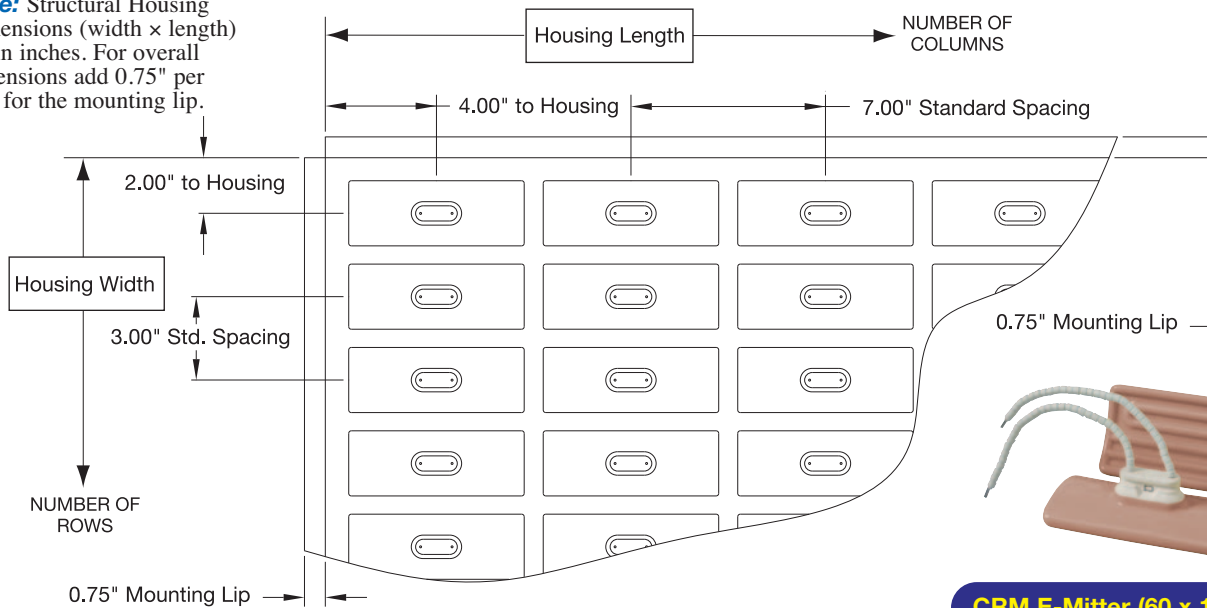

CRM E-Mitter (60 x 163 mm)

Custom Engineered/Manufactured Panels

- Multiple panels are used for larger arrays.
- Consult factory for larger panels not shown in table or custom panels with other spacings. Minimum spacing for CRM heaters is 2.50" x 7.00".
- Special narrow panels having a maximum 40 rows x 1, 2, or 3 columns, & up to 8 rows x 18 columns can be made on special order (max. housing size 127" x 25").

**Consult us with your requirements.
There is no substitute for our experience.**

⚠ WARNING: Cancer and Reproductive Harm - www.P65Warnings.ca.gov.

Series CRC and CRZ E-Mitter Panel Arrays Standard Style ARA Structural Housing Dimensions

- A) The Number of Rows will determine the Housing Width. For overall width add 1.50" (for the mounting lips).
 B) The Number of Columns will determine the Housing Length. For overall length add 1.50" (for the mounting lips).

Number of Rows	Number of Columns											
	1 W x L	2 W x L	3 W x L	4 W x L	5 W x L	6 W x L	7 W x L	8 W x L	9 W x L	10 W x L	11 W x L	12 W x L
1	4 x 6	4 x 11	4 x 16	4 x 21	4 x 26	4 x 31	4 x 36	4 x 41	4 x 46	4 x 51	4 x 56	4 x 61
2	7 x 6	7 x 11	7 x 16	7 x 21	7 x 26	7 x 31	7 x 36	7 x 41	7 x 46	7 x 51	7 x 56	7 x 61
3	10 x 6	10 x 11	10 x 16	10 x 21	10 x 26	10 x 31	10 x 36	10 x 41	10 x 46	10 x 51	10 x 56	10 x 61
4	13 x 6	13 x 11	13 x 16	13 x 21	13 x 26	13 x 31	13 x 36	13 x 41	13 x 46	13 x 51	13 x 56	13 x 61
5	16 x 6	16 x 11	16 x 16	16 x 21	16 x 26	16 x 31	16 x 36	16 x 41	16 x 46	16 x 51	16 x 56	16 x 61
6	19 x 6	19 x 11	19 x 16	19 x 21	19 x 26	19 x 31	19 x 36	19 x 41	19 x 46	19 x 51	19 x 56	19 x 61
7	22 x 6	22 x 11	22 x 16	22 x 21	22 x 26	22 x 31	22 x 36	22 x 41	22 x 46	22 x 51	22 x 56	22 x 61
8	25 x 6	25 x 11	25 x 16	25 x 21	25 x 26	25 x 31	25 x 36	25 x 41	25 x 46	25 x 51	25 x 56	25 x 61
9	28 x 6	28 x 11	28 x 16	28 x 21	28 x 26	28 x 31	28 x 36	28 x 41	28 x 46	28 x 51	—	—
10	31 x 6	31 x 11	31 x 16	31 x 21	31 x 26	31 x 31	31 x 36	31 x 41	—	—	—	—
11	34 x 6	34 x 11	34 x 16	34 x 21	34 x 26	34 x 31	34 x 36	34 x 41	—	—	—	—
12	37 x 6	37 x 11	37 x 16	37 x 21	37 x 26	37 x 31	37 x 36	37 x 41	—	—	—	—
13	40 x 6	40 x 11	40 x 16	40 x 21	40 x 26	40 x 31	—	—	Dimensions are in inches			—
14	43 x 6	43 x 11	43 x 16	43 x 21	43 x 26	43 x 31	—	—	—	—	—	—
15	46 x 6	46 x 11	46 x 16	46 x 21	46 x 26	46 x 31	—	—	—	—	—	—
16	49 x 6	49 x 11	49 x 16	49 x 21	—	—	—	—	—	—	—	—
17	52 x 6	52 x 11	52 x 16	52 x 21	—	—	—	—	—	—	—	—
18	55 x 6	55 x 11	55 x 16	55 x 21	—	—	—	—	—	—	—	—



Note: Structural Housing Dimensions (width x length) are in inches. For overall dimensions add 0.75" per side for the mounting lip.

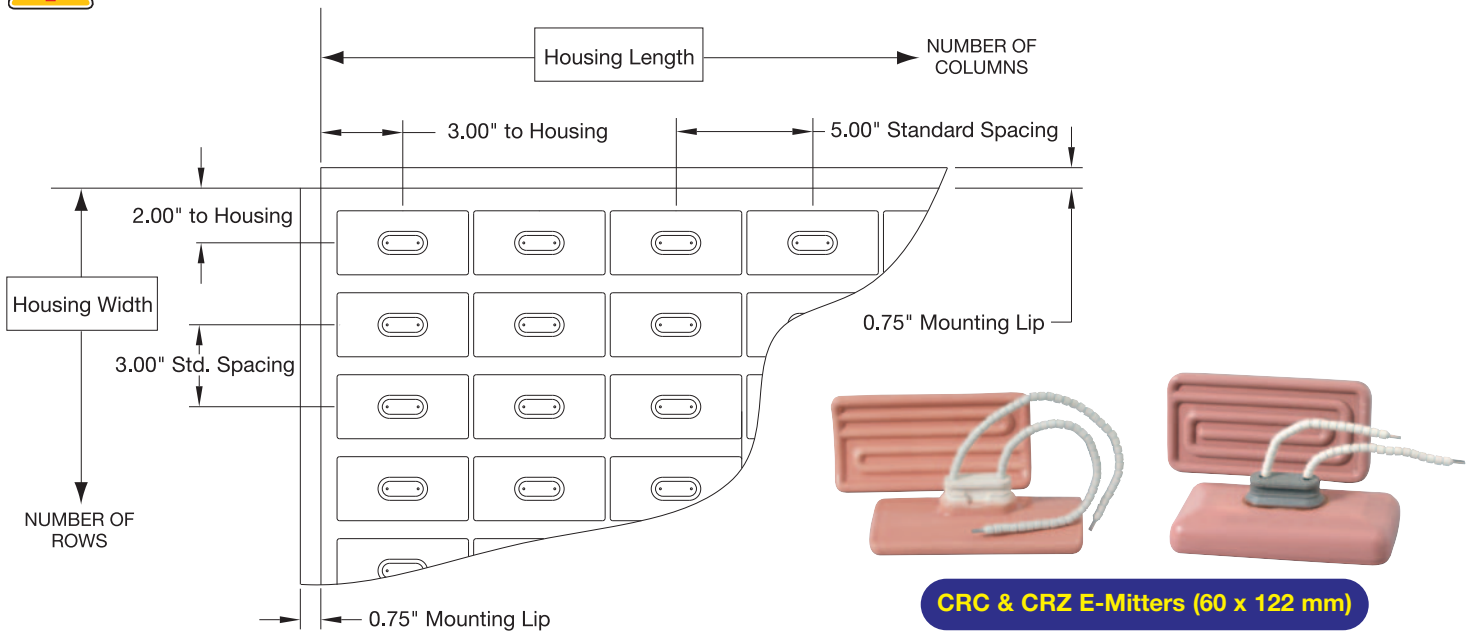

Custom Engineered/Manufactured Panels

- Multiple panels are used for larger arrays.
- Consult factory for larger panels not shown in table or custom panels with other spacings. Minimum spacing for CRC and CRZ heaters is 2.50" x 5.00".
- Special narrow panels having a maximum 40 rows x 1, 2, 3 or 4 columns, & up to 8 rows x 12 columns can be made on special order (max. housing size 121" x 25").

We welcome your inquiries.

Take advantage of Tempco's economical approach to manufacturing panels.

WARNING: Cancer and Reproductive Harm - www.P65Warnings.ca.gov.

Series CRL E-Mitter Panel Arrays Standard Style ARA Structural Housing Dimensions

A) The Number of Rows will determine the Housing Width. For overall width add 1.50" (for the mounting lips).
B) The Number of Columns will determine the Housing Length. For overall length add 1.50" (for the mounting lips).

Number of Rows	Number of Columns				
	1 W x L	2 W x L	3 W x L	4 W x L	5 W x L
1	5 x 12.5	5 x 24.5	5 x 36.5	5 x 48.5	5 x 60.5
2	9 x 12.5	9 x 24.5	9 x 36.5	9 x 48.5	9 x 60.5
3	13 x 12.5	13 x 24.5	13 x 36.5	13 x 48.5	13 x 60.5
4	17 x 12.5	17 x 24.5	17 x 36.5	17 x 48.5	17 x 60.5
5	21 x 12.5	21 x 24.5	21 x 36.5	21 x 48.5	21 x 60.5
6	25 x 12.5	25 x 24.5	25 x 36.5	25 x 48.5	25 x 60.5
7	29 x 12.5	29 x 24.5	29 x 36.5	29 x 48.5	—
8	33 x 12.5	33 x 24.5	33 x 36.5	—	—
9	37 x 12.5	37 x 24.5	37 x 36.5	—	—
10	41 x 12.5	41 x 24.5	41 x 36.5	—	—
11	45 x 12.5	45 x 24.5	45 x 36.5	—	—
12	49 x 12.5	49 x 24.5	—	—	—
13	53 x 12.5	53 x 24.5	Dimensions are in inches		
14	57 x 12.5	57 x 24.5			
15	61 x 12.5	61 x 24.5	—	—	—



Note: Structural Housing Dimensions (width x length) are in inches. For overall dimensions add 0.75" per side for the mounting lip.

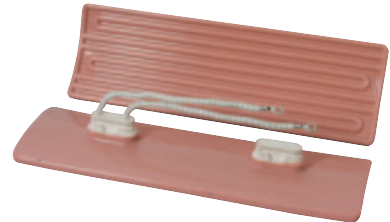
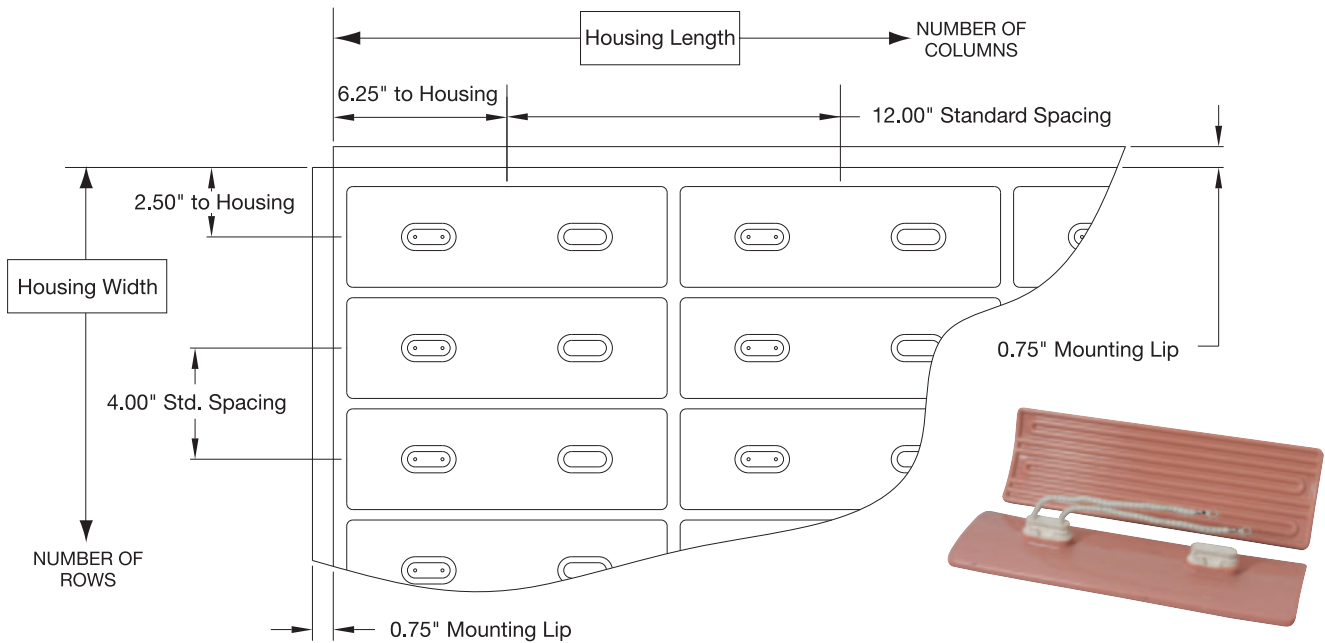

CRL E-Mitter (95 x 295 mm)

Custom Engineered/Manufactured Panels

- Multiple panels are used for larger arrays.
- Consult factory for larger panels not shown in table or custom panels with other spacings. Minimum spacing for CRL heaters is 4.00" x 12.00".
- Special narrow panels having a maximum 30 rows x 1 or 2 columns, & up to 6 rows x 9 columns can be made on special order (max. housing size 121" x 25").

**Consult us with your requirements
There is no substitute for our experience.**

⚠ WARNING: Cancer and Reproductive Harm - www.P65Warnings.ca.gov.

Series CRH and CRG E-Mitter Panel Arrays Standard Style ARA Structural Housing Dimensions

A) The Number of Rows will determine the Housing Width. For overall width add 1.50" (for the mounting lips).
 B) The Number of Columns will determine the Housing Length. For overall length add 1.50" (for the mounting lips).

Number of Rows	Number of Columns											
	1 W x L	2 W x L	3 W x L	4 W x L	5 W x L	6 W x L	7 W x L	8 W x L	9 W x L	10 W x L	11 W x L	12 W x L
1	6 x 6	6 x 11	6 x 16	6 x 21	6 x 26	6 x 31	6 x 36	6 x 41	6 x 46	6 x 51	6 x 56	6 x 61
2	11 x 6	11 x 11	11 x 16	11 x 21	11 x 26	11 x 31	11 x 36	11 x 41	11 x 46	11 x 51	11 x 56	11 x 61
3	16 x 6	16 x 11	16 x 16	16 x 21	16 x 26	16 x 31	16 x 36	16 x 41	16 x 46	16 x 51	16 x 56	16 x 61
4	21 x 6	21 x 11	21 x 16	21 x 21	21 x 26	21 x 31	21 x 36	21 x 41	21 x 46	21 x 51	21 x 56	21 x 61
5	26 x 6	26 x 11	26 x 16	26 x 21	26 x 26	26 x 31	26 x 36	26 x 41	26 x 46	26 x 51	26 x 56	26 x 61
6	31 x 6	31 x 11	31 x 16	31 x 21	31 x 26	31 x 31	31 x 36	31 x 41	31 x 46	31 x 51	—	—
7	36 x 6	36 x 11	36 x 16	36 x 21	36 x 26	36 x 31	36 x 36	36 x 41	36 x 46	—	—	—
8	41 x 6	41 x 11	41 x 16	41 x 21	41 x 26	41 x 31	41 x 36	41 x 41	—	—	—	—
9	46 x 6	46 x 11	46 x 16	46 x 21	46 x 26	46 x 31	46 x 36	—	—	Dimensions are in inches		
10	51 x 6	51 x 11	51 x 16	51 x 21	51 x 26	51 x 31	—	—				
11	56 x 6	56 x 11	56 x 16	56 x 21	56 x 26	—	—	—	—	—	—	—
12	61 x 6	61 x 11	61 x 16	61 x 21	61 x 26	—	—	—	—	—	—	—



Note: Structural Housing Dimensions (width x length) are in inches. For overall dimensions add 0.75" per side for the mounting lip.

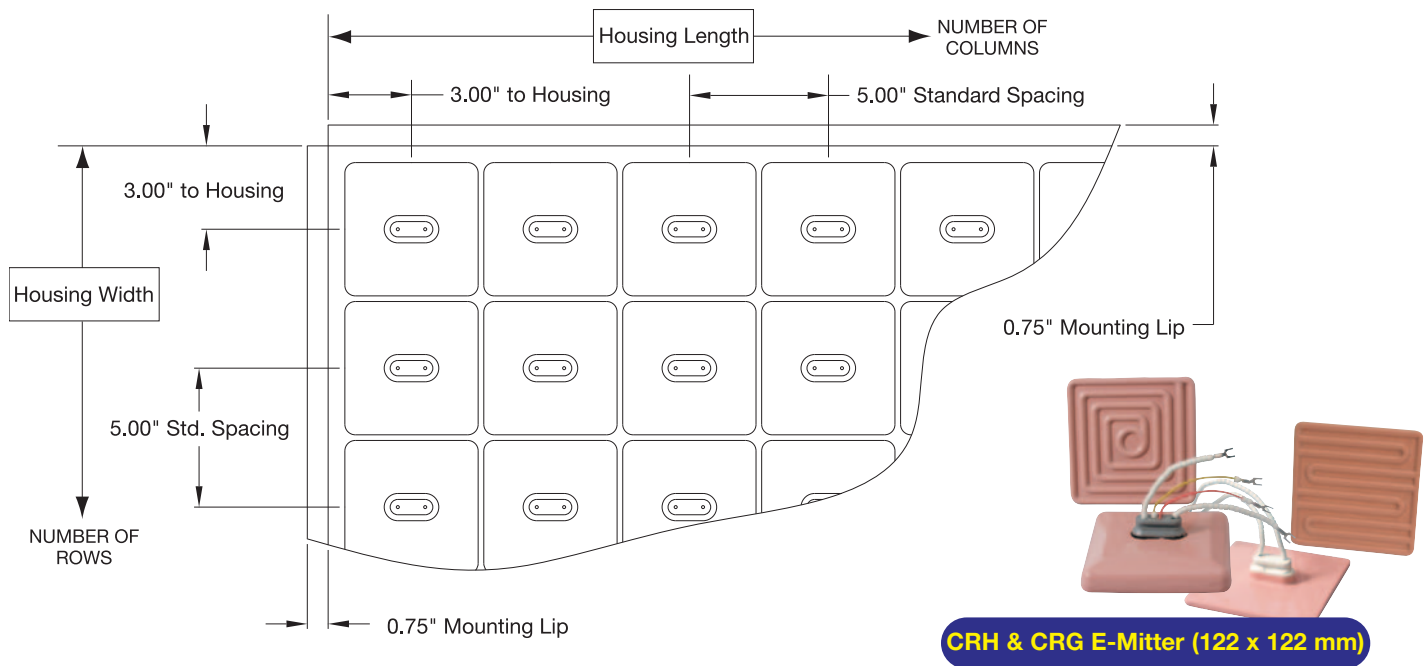

Custom Engineered/Manufactured Panels

- Multiple panels are used for larger arrays.
- Consult factory for larger panels not shown in table or custom panels with other spacings. Minimum spacing for CRH and CRG heaters is 5.00" x 5.00".
- Special narrow panels having a maximum 25 rows x 1 or 2 columns, & up to 8 rows x 9 columns can be made on special order (max. housing size 121" x 26").

We welcome your inquiries.
Take advantage of Tempco's economical approach to manufacturing panels.

WARNING: Cancer and Reproductive Harm - www.P65Warnings.ca.gov.



ARA Array Assemblies for CRD E-Mitters



Design Features

- * *Lightweight extruded aluminum outer housing.*
- * *All metal interior components are stainless steel.*
- * *Designed for use with Style CRD E-Mitters, pages 7-10 and 7-11.*
- * *Each heater's power leads are connected to an individual ceramic Terminal Block.*
- * *NCC or Nickel wire with heat resistant insulation is used for wiring between terminal blocks.*
- * *Zones with different radiant heat levels can be achieved by using different wattage heaters (each zone would have a heater with built-in thermocouple for temperature control).*
- * *Shipped fully assembled.*
- * *Optional factory wiring and power control panels.*
- * *Optional ceramic fiber insulation in wiring space.*
- * *Optional entrances in rear cover or sides to customer specs.*

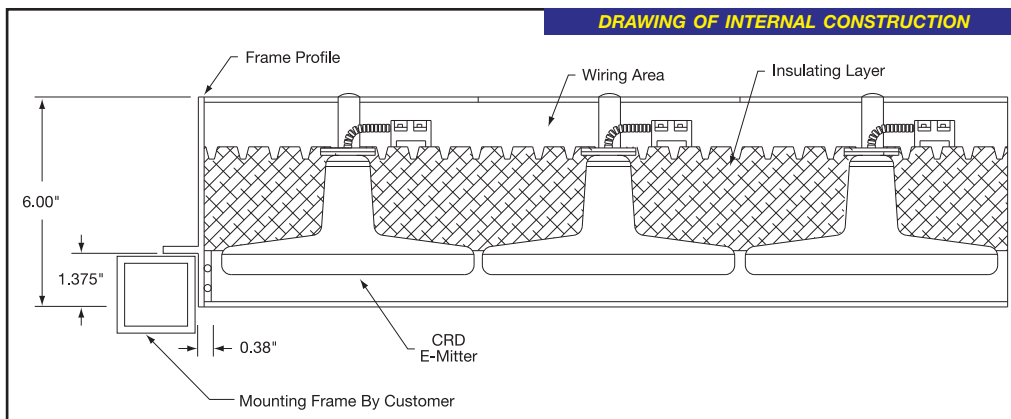

The housing for the CRD heaters is the same construction as all ARA arrays except for the extra height needed for the long shaft of the CRD heaters. This space is then filled with ceramic fiber insulation with foil backing to keep the wiring and terminal area much cooler.

Ordering Information

Refer to the worksheet on page 7-36



Series CRD E-Mitter Panel Arrays Standard Style ARA Structural Housing Dimensions

- A) The Number of Rows will determine the Housing Width. For overall width add 1.50" (for the mounting lips).
 B) The Number of Columns will determine the Housing Length. For overall length add 1.50" (for the mounting lips).

Number of Rows	Number of Columns											
	1 W x L	2 W x L	3 W x L	4 W x L	5 W x L	6 W x L	7 W x L	8 W x L	9 W x L	10 W x L	11 W x L	12 W x L
1	6 x 6	6 x 11	6 x 16	6 x 21	6 x 26	6 x 31	6 x 36	6 x 41	6 x 46	6 x 51	6 x 56	6 x 61
2	11 x 6	11 x 11	11 x 16	11 x 21	11 x 26	11 x 31	11 x 36	11 x 41	11 x 46	11 x 51	11 x 56	11 x 61
3	16 x 6	16 x 11	16 x 16	16 x 21	16 x 26	16 x 31	16 x 36	16 x 41	16 x 46	16 x 51	16 x 56	16 x 61
4	21 x 6	21 x 11	21 x 16	21 x 21	21 x 26	21 x 31	21 x 36	21 x 41	21 x 46	21 x 51	21 x 56	21 x 61
5	26 x 6	26 x 11	26 x 16	26 x 21	26 x 26	26 x 31	26 x 36	26 x 41	26 x 46	26 x 51	26 x 56	26 x 61
6	31 x 6	31 x 11	31 x 16	31 x 21	31 x 26	31 x 31	31 x 36	31 x 41	31 x 46	31 x 51	—	—
7	36 x 6	36 x 11	36 x 16	36 x 21	36 x 26	36 x 31	36 x 36	36 x 41	36 x 46	—	—	—
8	41 x 6	41 x 11	41 x 16	41 x 21	41 x 26	41 x 31	41 x 36	41 x 41	—	—	—	—
9	46 x 6	46 x 11	46 x 16	46 x 21	46 x 26	46 x 31	46 x 36	—	—	Dimensions are in inches		
10	51 x 6	51 x 11	51 x 16	51 x 21	51 x 26	51 x 31	—	—				
11	56 x 6	56 x 11	56 x 16	56 x 21	56 x 26	—	—	—	—	—	—	—
12	61 x 6	61 x 11	61 x 16	61 x 21	61 x 26	—	—	—	—	—	—	—



Note: Structural Housing Dimensions (width x length) are in inches. For overall dimensions add 0.75" per side for the mounting lip.

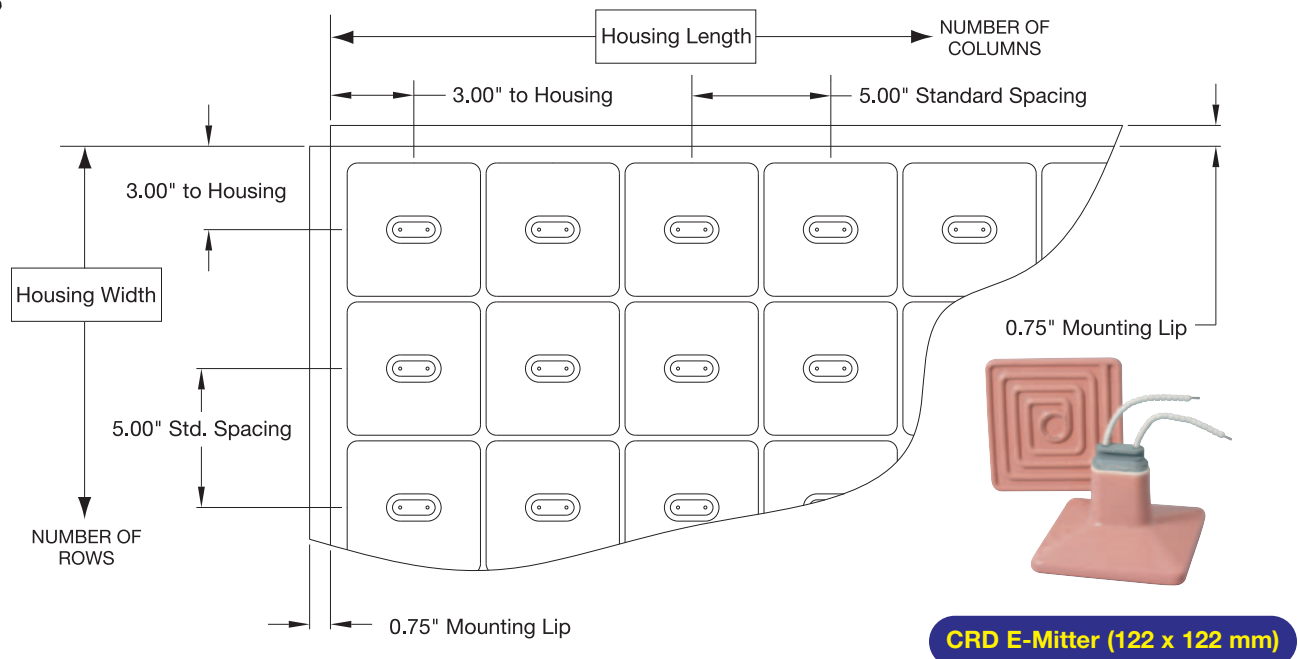

Custom Engineered/Manufactured Panels

- Multiple panels are used for larger arrays.
- Consult factory for larger panels not shown in table or custom panels with other spacings. Minimum spacing for CRD heaters is 5.00" x 5.00".
- Special narrow panels having a maximum 25 rows x 1 or 2 columns, & up to 8 rows x 9 columns can be made on special order (max. housing size 121" x 26").

We welcome your inquiries.
Take advantage of Tempco's economical approach to manufacturing panels.

WARNING: Cancer and Reproductive Harm - www.P65Warnings.ca.gov.



Ordering Information

ARA Array Panel Design Worksheet for Ceramic E-Mitters

Ordering Information

To process your order or quotation, please specify the following information.

1.) Supply panel layout or sketch showing:

- Outside panel dimensions (allow for 0.75" wide mounting lip on all sides of ARA structural array housing)
- Heater type and orientation of long (or short) heater dimension
- Layout of rows and columns with number of heaters
- Spacing of rows and columns (Tempco will use standard spacing unless specified by customer)
- Zones and/or number of heaters per zone
- Locations of input wiring
- Locations of heaters with thermocouples (if used)

2.) Electrical requirements:

- Total panel KW _____
- Zone KWs (or # of heaters in zones) _____
- Line voltage to panel, # of circuits & 1 or 3 phase operation _____
- If 480V, can series-parallel wiring and 240V heaters be used? _____
- Type of heater control to be used _____

3.) Heater specifications:

- E-Mitter Style CRB CRC CRG CRN CRZ CRD CRH CRL CRM
- Catalog Part Number _____ or Watts _____ Volts _____ Color for all heaters (T/C & non-T/C types) _____
- Standard K thermocouple or optional J _____ Quantity _____
- Heater lead configuration (Standard is 3.5" ceramic beads with spade terminals if factory wired)
Special terminals if required _____

4.) Panel wiring & control options:

- Standard unit wiring is heaters to terminal blocks only
- Factory wired per customer specs and wiring diagram
- Tempco Engineering to design internal wiring and determine line input requirements
- Tempco to supply turnkey power control panel(s)

5.) Any special features required? _____

6.) Application data:

- Type of application and physical properties of processed materials _____

 **WARNING:** Cancer and Reproductive Harm - www.P65Warnings.ca.gov.



ARA Array Housing Assemblies for Any Style Ceramic E-Mitter



17.5 KW 380V 4-Zone
CRH E-Mitters

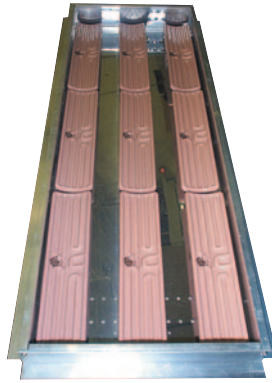

9 KW 480V 3-Zone
3 x 3 CRB E-Mitters



4 Rows CRH E-Mitters
4 Rows CRZ E-Mitters (at ends)



There Is No Substitute For Our Experience

Complete, made-to-order infrared heating systems – including the power and process temperature control panel – are available. Our team of professionals will assist you from concept to design/manufacturing. We Welcome Your Inquiries.

Assembly and Wiring of a Custom E-Mitter Panel



Power/Temperature Control Panels



Design Features

- * Solid state or mechanical load switching
- * Temperature control
- * Over-temperature control — A second thermocouple senses for over-temperature, shutting down the system while activating a signal light or optional alarm horn. Solid State controls and mechanical contactors can fail in the on position so it is very important to have this safety backup feature.
- * Control circuit transformer with primary and secondary fusing
- * NEMA 12 enclosure — NEMA 1 construction
- * Manual disconnect switch with interlocking operating mechanism so power must be off in order to open cabinet
- * Cooling fan and filter for solid state units
- * Wiring diagram, parts list and operating instructions



Note: See pages 13-56 through 13-63 for more information on Power and Temperature Control Panels.

Radiant Process Heaters



Series CRE and CRR E-Mitters

Type CRE & CRR Edison Screw-In Bulb E-Mitters



Type CRE
Bulb Shape

Type CRR
Flat Face

Design Features

- * Provides safe, clean, radiant heat anywhere
- * Easy installation
- * Not affected by vibration— high mechanical strength
- * Good resistance to atmospheric contamination
- * Does not generate visible light— only heat
- * Reversible color change feature
- * 3.5 to 7 μ m infrared radiation peak wavelength

Edison Screw-In Bulb E-Mitters

The CRE and CRR Style E-Mitters are hollow ceramic heaters with a unique thin wall construction and geometrical shape to facilitate fast heating and cooling rates.

The resistance coil is embedded into the specially designed circular ceramic E-mitter surface, providing extremely uniform heat transmission with low element surface temperatures.

Because of the convenient Edison Screw-In style termination, CRE & CRR E-Mitters are recognized as a tremendously versatile source for localized spot heating. They can be used virtually anywhere quickly and easily by simply installing the CRE E-Mitter into common porcelain/ceramic insulated bulb sockets—like any ordinary light bulb.

Typical Applications

- Plastic Thermoforming and vacuum forming
- Curing adhesives
- Curing dental composite material
- Heating laboratory samples and specimens
- Comfort heat for agricultural, zoological and reptilian pet applications
- Preventing moisture accumulation and freezing in electrical control boxes
- Preventing moisture accumulation, mildew and freezing in clothes lockers
- Resistor Banks
- Agricultural
- Agency Approval: 



Screw-In Base

Ceramic receptacle for use with screw-in bulb E-Mitters

Part Number: CRK00016

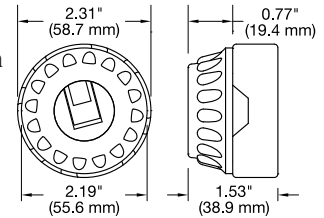

Type CRE & CRR E-Mitters



Ordering Information

Catalog Heaters

For shipment directly from Stock, choose the Ceramic Infrared Radiant Heater from the stock list that fills your requirements.

Optional metamorphing yellow or straight black can be manufactured to order to meet your requirements. A part number will be assigned when an order is placed.

Custom Engineered/Manufactured Heaters

Understanding that an electric heater can be very application specific, for sizes and ratings not listed, **TEMPCO** will design and manufacture a CRE & CRR Bulb Style Ceramic Infrared Heater to meet your requirements. **Standard lead time is 3 weeks.**

Please Specify the following:

- Size:** Overall dimensions or Series Code
- Colors:** Standard colors are metamorphing rose and white; optional colors are metamorphing yellow and straight black
- Wattage:** Description of process and temperature required

⚠ WARNING: Cancer and Reproductive Harm - www.P65Warnings.ca.gov.

Type CRE Edison Screw-In Bulb E-Mitters

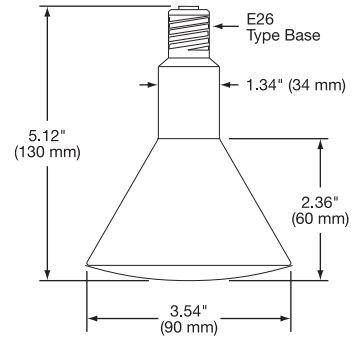
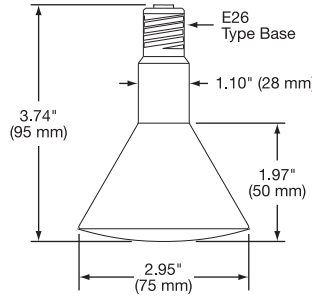
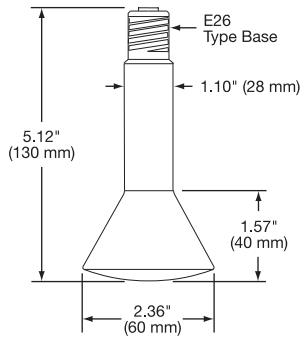

Standard (Non-Stock) CRE E-Mitters

Diameter	Wattage	Voltage	Color	Watt Density		*Surface Temperature (Typical)		Part Number
				(W/in ²)	(W/cm ²)	°F	°C	
60mm	60	120	Rose to Grey	13.26	6.45	842	450	CRE10014
	60	120	White	13.26	6.45	842	450	CRE00014
	100	120	Rose to Grey	22.60	10.76	887	477	CRE10015
	100	120	White	22.60	10.76	887	477	CRE00015
75mm	60	120	Rose to Grey	8.49	1.32	662	350	CRE10012
	60	120	White	8.49	1.32	662	350	CRE00012
	100	120	Rose to Grey	14.15	2.19	788	420	CRE10013
	100	120	White	14.15	2.19	788	420	CRE00013
90mm	150	120	Rose to Grey	15.59	2.41	842	450	CRE10008
	150	120	White	15.59	2.41	842	450	CRE00008
	250	120	Rose to Grey	22.98	4.02	986	530	CRE10002
	250	120	White	22.98	4.02	986	530	CRE00002

Type CRR Edison Screw-In Bulb E-Mitters

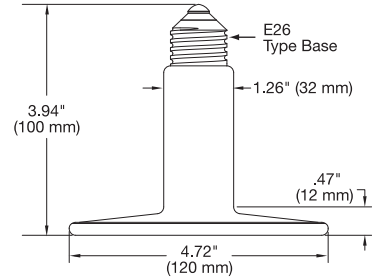
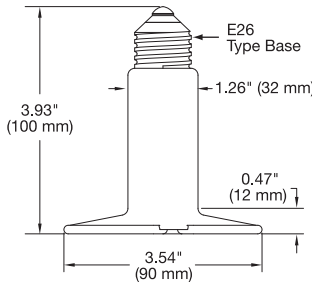
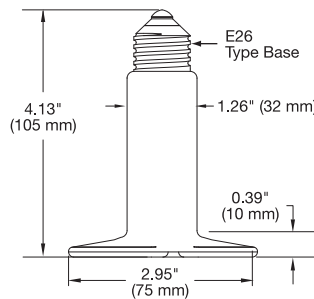

Standard (Non-Stock) CRR E-Mitters (Color – White)

Diameter	Wattage	Watt Density		*Surface Temperature (Typical)		Part Number 120V
		(W/in ²)	(W/cm ²)	°F	°C	
75mm	60	8.77	1.36	640	338	CRR00005
	100	14.62	2.26	710	377	CRR00006
	100	10.16	1.57	655	346	CRR00003
90mm	150	15.24	2.36	760	404	CRR00004
	200	20.32	3.14	950	510	CRR00007
	100	5.71	0.88	400	204	CRR00008
120mm	150	8.57	1.33	485	252	CRR00009
	200	14.29	2.21	670	354	CRR00010

*E-Mitter (operating in 72°F/22°C ambient) face temperature measured with internal thermocouple.

Radiant Process Heaters



Series CRT E-Mitters

Stock CRT E-Mitters

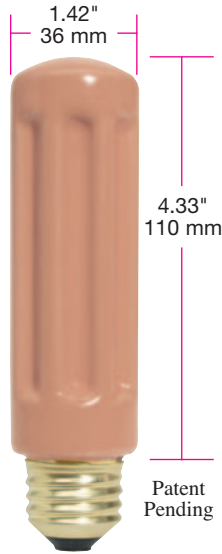

Series CRT – Tube Shaped E-Mitter

Tempco's Edison Screw-In Bulb Series CRT E-Mitter is a hollow, tube-shaped ceramic heater ideally suited for wide area heating. Standard colors are metamorphing rose and straight white; optional are metamorphing yellow and straight black.

Typical Applications

- Preventing moisture accumulation and freezing in electrical control boxes
- Preventing moisture accumulation, mildew and freezing in clothes lockers
- Resistor Banks
- Incubators

Standard (Non-Stock) and Stock CRT E-Mitters (Color – METAMORPHING Rose to Grey)

Stock Items Are Shown In RED

Wattage	*Surface Temperature (Typical)		Part Number	
	°F	°C	120V	240V
50	464	240	CRT10100	—
75	567	297	CRT10101	CRT10106
100	671	355	CRT10102	CRT10107
150	824	440	CRT10103	CRT10108
200	937	503	CRT10104	CRT10109
250	1049	565	CRT10105	CRT10110

*E-Mitter (operating in 72°F/22°C ambient) surface temperature measured with a thermocouple.



Screw-In Base

Ceramic receptacle for use with screw-in bulb E-Mitters

Part Number: CRK00016

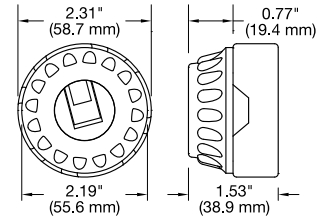

Ordering Information

Standard Heaters

Order by Part Number for Stock heaters.

Custom Engineered/Manufactured Heaters

Understanding that an electric heater can be very application specific, for sizes and ratings not listed, **TEMPCO** can manufacture a CRT E-Mitter to meet your requirements. **Standard lead time is 3 weeks.**

Please Specify the following:

- Colors:** Standard are metamorphing rose and straight white, optional are metamorphing yellow and straight black
- Housing:** NEMA 1 (if required)
- Voltage:** 120 or 240
- Wattage:** 250W maximum

⚠ WARNING: Cancer and Reproductive Harm - www.P65Warnings.ca.gov.

EHC Ceramic E-Mitter Enclosure Heaters

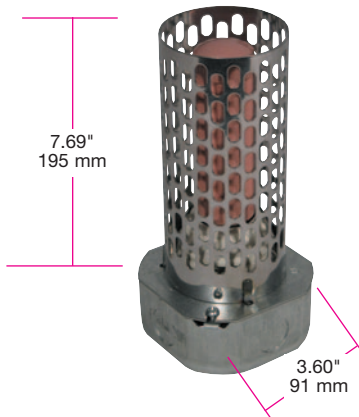

Typical Applications

- ➔ Traffic Signal Control Boxes
- ➔ Automatic Teller Machines (ATMs)
- ➔ Outdoor Electrical Power Enclosures
- ➔ Control Panels
- ➔ Control Valve Housings
- ➔ Switch Gear
- ➔ Clothing Lockers

Tempco enclosure heaters are the answer to all your enclosure heater needs. Our heaters are designed to help electric, electronic, pneumatic, hydraulic and mechanical equipment perform at top capacity by protecting them against low temperatures, condensation and corrosion. Tempco offers many different styles of heaters that can be used in enclosure heating applications. Our most popular styles are displayed below.

EHC Enclosure Heaters with NEMA 1 Housing

Watts	Volts	Color	Part Number	Replacement Heater Bulb
50	120	Rose to Grey	EHC10100	CRT10100
75	120	Rose to Grey	EHC10101	CRT10101
75	240	Rose to Grey	EHC10106	CRT10106
100	120	Rose to Grey	EHC10102	CRT10102
100	240	Rose to Grey	EHC10107	CRT10107
150	120	Rose to Grey	EHC10103	CRT10103
150	240	Rose to Grey	EHC10108	CRT10108
200	120	Rose to Grey	EHC10104	CRT10104
200	240	Rose to Grey	EHC10109	CRT10109
250	120	Rose to Grey	EHC10105	CRT10105
250	240	Rose to Grey	EHC10110	CRT10110

See page 11-114 for help in sizing and determining the best enclosure heater for your application.

EHA — Remote Thermostats for Enclosure Heaters



See Page 9-18 for details

Stock EHA Remote Thermostats

Opens °F	Closes °F	Part Number
60±5	40±7	EHA00001
140±5	110±10	EHA00002
180±5	150±10	EHA00003

Other Types of Enclosure Heaters

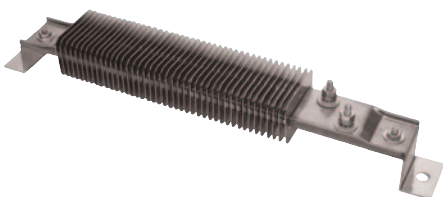

Finned Strip Heater
See Page 8-14



Silicone Rubber Heater
See Page 9-18

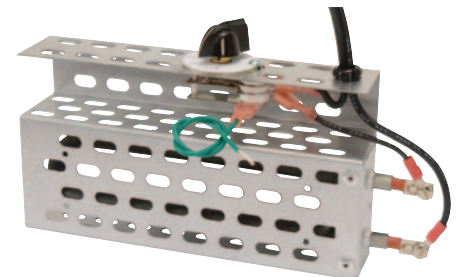

Tubular Heater
See Page 11-115

High Intensity Medium Wave Quartz Mini-Tube Infrared Heaters KTE (Translucent Tubes) & KTG (Clear Tubes with Gold Coated Ceramic Backing)

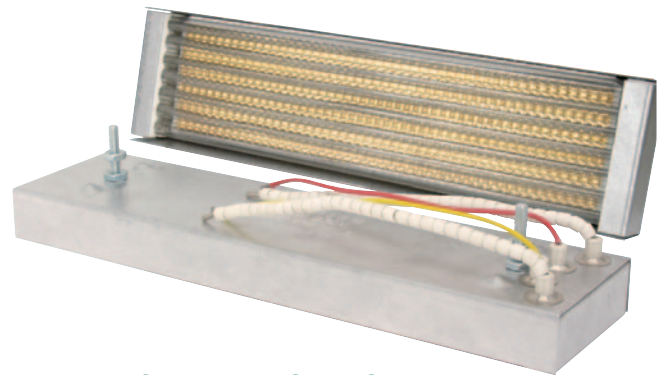
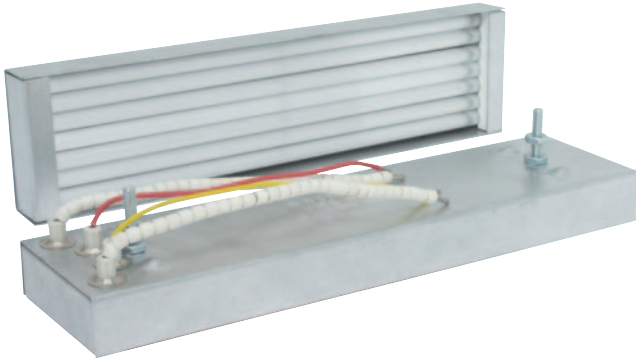

Series KTE – Translucent Tubes

Series KTG – Clear Tubes with Gold Coated Ceramic Backing

Up to 95% reflective efficiency using gold coated ceramic backing

Design Features

- * Standard industry sizes and ratings up to 60 w/in² (interchangeable with CRC, CRB, CRN and CRZ ceramic heaters).
- * Highly reflective rugged aluminized steel housing construction.
- * Rapid response – 2.5 to 7.5 deg F / sec. heat-up / cool-down rates, depending on unit watt density.
- * Medium wavelength output (2.5 – 6 microns).
- * Standard winding pattern gives uniform heating over entire face of heater. (Consult factory for custom or high intensity winding patterns and/or sizes.)
- * Optional built-in type K or J T/C available in center of unit face.
- * Ideal for systems requiring small area zoning and close control of process.
- * Best when used at radiation distances of 4 – 10" from work.
- * Suitable for horizontal or vertical operation with tubes in horizontal plane.
- * Designed for use in CRA linear structural housings and ARV array assemblies. See pages 7-48 through 7-51.
- * 120, 208, 240, 277 or 480V design (consult factory for 575V units)

Typical Applications

- ➔ Ideal for drying, adhesive and epoxy bonding/curing
- ➔ Laminating
- ➔ Shrink packaging
- ➔ Thermoforming plastics
- ➔ Other processes requiring fast penetration of heat into metals, wood, synthetic fabrics, and plastics

Ordering Information

Custom Engineered/Manufactured KTE Heaters

An electric heater can be very application specific; for sizes not listed, TEMPCO will design and manufacture a KTE or KTG E-Mitter or complete system to meet your requirements.

Standard lead time is 3 weeks.

Please Specify the following:

Standard Heaters

Order by Part Number for Standard heaters.

- Housing Length
- Housing Width
- Mounting Style (S, C)
- Wattage
- Voltage
- KTE Translucent Quartz or KTG Clear Tubes with Gold Coated Ceramic Backing
- Beaded Lead Length: Standard 6"
- Thermocouple: Optional Type K (Standard 6")
- Options and Accessories: See pages 7-20 through 7-23

⚠ WARNING: Cancer and Reproductive Harm - www.P65Warnings.ca.gov.

6 Standard KTE & KTG Housing Sizes Available

Series KTE1 & KTG1

- 9.75" × 2.46" (247.7 × 62.5 mm)
Available in Two Constructions
- Translucent Tubes (KTE1)
 - Clear Tubes with Hi-Efficiency Gold Coated Ceramic Backing (KTG1)

Series KTE2 & KTG2

- 4.88" × 2.46" (123.8 × 62.5 mm)
Available in Two Constructions
- Translucent Tubes (KTE2)
 - Clear Tubes with Hi-Efficiency Gold Coated Ceramic Backing (KTG2)

Series KTE3 & KTG3

- 7.31" × 2.46" (185.7 × 62.5 mm)
Available in Two Constructions
- Translucent Tubes (KTE3)
 - Clear Tubes with Hi-Efficiency Gold Coated Ceramic Backing (KTG3)

Series KTE4 & KTG4

- 14.63" × 2.46" (371.5 × 62.5 mm)
Available in Two Constructions
- Translucent Tubes (KTE4)
 - Clear Tubes with Hi-Efficiency Gold Coated Ceramic Backing (KTG4)

Series KTE5

- 19.50" × 2.46" (495.3 × 62.5 mm)
Available with Translucent Tubes only

Series KTE6 & KTG6

- 4.88" Square (123.8 mm)
– Translucent Tubes (KTE6)
– Clear Tubes with Hi-Efficiency Gold Coated Ceramic Backing (KTG6)

2 Universal Mounting Styles (C & S) Available

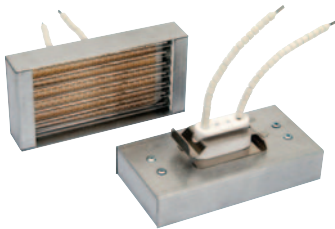

Style C – Single Ceramic Header with Leads
(Shown with Clear Tubes with Hi-Efficiency Gold Coated Ceramic Backing)

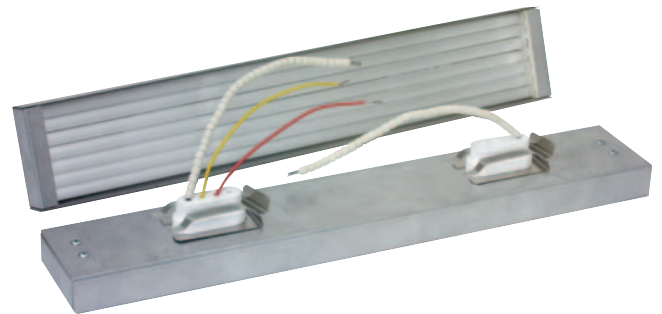

Style C – Two Ceramic Headers with Leads
(Shown with Translucent Tubes and T/C)

INTERCHANGEABLE MOUNTING DESIGN

Style C KTE and KTG E-Mitters have a Standard Ceramic Mounting Head and are interchangeable with CRC, CRB, CRN and CRZ Ceramic E-Mitters.

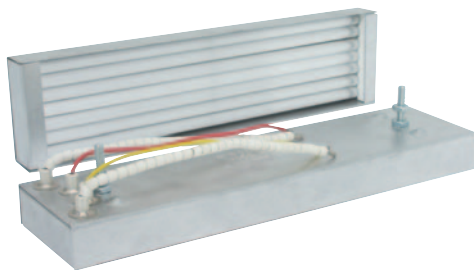

Style S – Two 10-32 Studs × 1" on centerline
(Shown with Translucent Tubes and T/C)

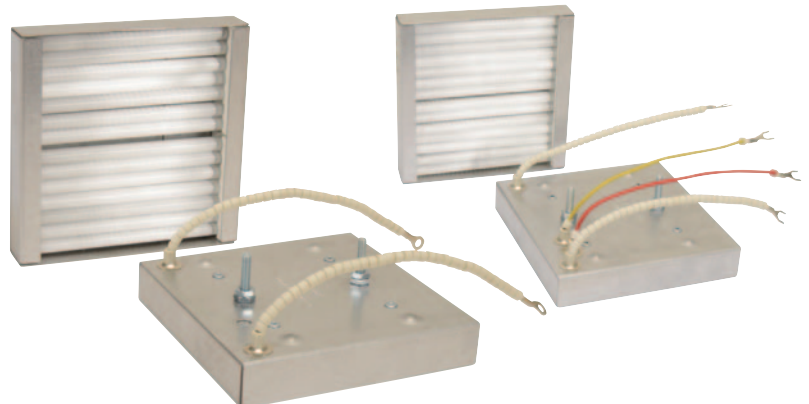

Radiant Process Heaters



KTE & KTG Series Style C

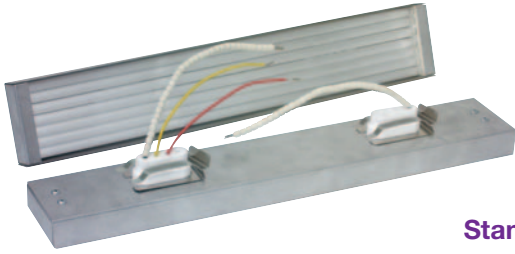

Series Style C (Ceramic Header with Leads) High Intensity Quartz Mini-Tube Infrared Heaters KTE (Translucent Tubes) & KTG (Clear Tubes with Gold Coated Ceramic Backing)

Standard (Non-Stock) Sizes and Ratings

Heaters listed have ceramic bead insulated leads (single head 3.5", dual head 6"), #8-10 spade terminals, and one-piece spring clips for mounting in 20 or 22 gauge sheet metal.

Wattage	Volts	Drawing	"A" Dim. in mm	"B" Dim. in mm	Translucent Tubes		Gold Coated Ceramic Backing	
					Part Number without Thermocouple	Part Number with Optional Type K Thermocouple	Part Number without Thermocouple	Part Number with Optional Type K Thermocouple
125	220/240	C1 (Single Head)	4.88 123.8	N/A N/A	KTE20015	KTE20016	KTG20011	KTG20012
200	220/240	C1 (Single Head)			KTE20017	KTE20018	KTG20013	KTG20014
250	220/240	C1 (Single Head)			KTE20019	KTE20020	KTG20015	KTG20016
325	220/240	C1 (Single Head)			KTE20021	KTE20022	KTG20017	KTG20018
500	220/240	C1 (Single Head)			KTE20023	KTE20024	KTG20019	KTG20020
185	220/240	C1 (Single Head)	7.31 185.7	N/A N/A	KTE30011	KTE30012	KTG30011	KTG30012
300	220/240	C1 (Single Head)			KTE30013	KTE30014	KTG30013	KTG30014
375	220/240	C1 (Single Head)			KTE30015	KTE30016	KTG30015	KTG30016
500	220/240	C1 (Single Head)			KTE30017	KTE30018	KTG30017	KTG30018
750	220/240	C1 (Single Head)			KTE30019	KTE30020	KTG30019	KTG30020
250	220/240	C1 (Single Head)	9.75 247.7	N/A N/A	KTE10023	KTE10024	KTG10012	KTG10013
400	220/240	C1 (Single Head)			KTE10025	KTE10026	KTG10014	KTG10015
500	220/240	C1 (Single Head)			KTE10027	KTE10028	KTG10016	KTG10017
650	220/240	C1 (Single Head)			KTE10029	KTE10030	KTG10018	KTG10019
1000	220/240	C1 (Single Head)			KTE10031	KTE10032	KTG10020	KTG10021
375	220/240	C1 (Double Head)	14.63 371.5	7.40 188.1	KTE40011	KTE40012	KTG40011	KTG40012
600	220/240	C1 (Double Head)			KTE40013	KTE40014	KTE40013	KTE40014
750	220/240	C1 (Double Head)			KTE40015	KTE40016	KTG40015	KTG40016
1000	220/240	C1 (Double Head)			KTE40017	KTE40018	KTG40017	KTG40018
1500	220/240	C1 (Double Head)			KTE40019	KTE40020	KTG40019	KTG40020
500	220/240	C1 (Double Head)	19.50 495.3	9.88 250.8	KTE50011	KTE50012	—	—
800	220/240	C1 (Double Head)			KTE50013	KTE50014	—	—
1000	220/240	C1 (Double Head)			KTE50015	KTE50016	—	—
1500	220/240	C1 (Double Head)			KTE50017	KTE50018	—	—
2000	220/240	C1 (Double Head)			KTE50019	KTE50020	—	—
250	220/240	C2	See Drawing		KTE60011	KTE60012	KTG60011	KTG60012
400	220/240	C2			KTE60013	KTE60014	KTG60013	KTG60014
500	220/240	C2			KTE60015	KTE60016	KTG60015	KTG60016
650	220/240	C2			KTE60017	KTE60018	KTG60017	KTG60018
1000	220/240	C2			KTE60019	KTE60020	KTG60019	KTG60020

Drawing C1 – Single and Double Head Rectangular Heater

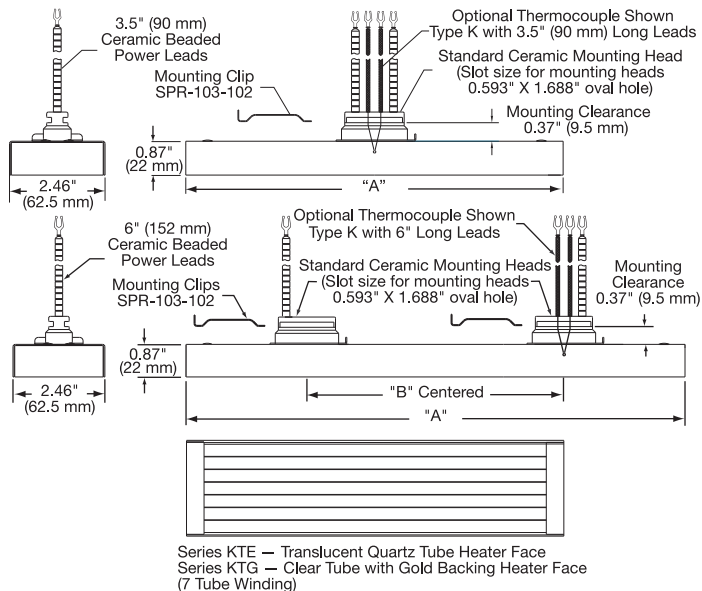

Drawing C2 – Single Head Square Heater

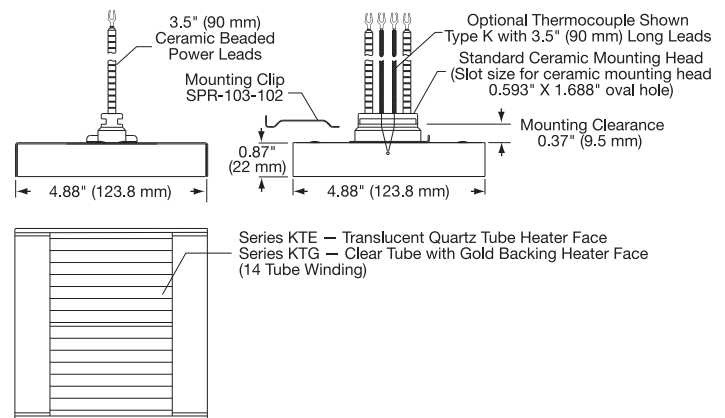



Series Style S (Mounting Studs)
High Intensity Quartz Mini-Tube Infrared Heaters
KTE (Translucent Tubes)
& KTG (Clear Tubes with Gold Coated Ceramic Backing)

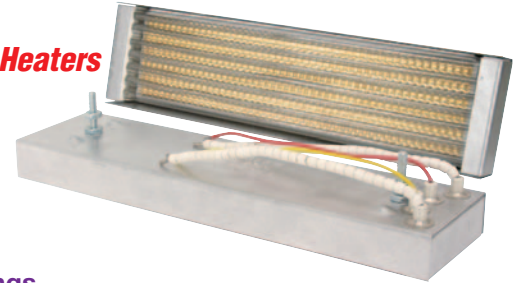

Standard (Non-Stock) Sizes and Ratings

Heaters listed have 6" ceramic bead insulated leads with #8-10 spade terminals.

Wattage	Volts	Drawing	"A" Dim. in mm	"B" Dim. in mm	Translucent Tubes		Gold Coated Part Number without Thermocouple	Ceramic Backing Part Number with Optional Type K Thermocouple
					Part Number without Thermocouple	Part Number with Optional Type K Thermocouple		
125	220/240	S1	4.88 123.8	2.50 63.5	KTE20001	KTE20002	KTG20001	KTG20002
200	220/240	S1			KTE20003	KTE20004	KTG20003	KTG20004
250	220/240	S1			KTE20005	KTE20006	KTG20005	KTG20006
325	220/240	S1			KTE20007	KTE20008	KTG20007	KTG20008
500	220/240	S1			KTE20009	KTE20010	KTG20009	KTG20010
185	220/240	S1	7.31 185.7	4.94 125.4	KTE30001	KTE30002	KTG30001	KTG30002
300	220/240	S1			KTE30003	KTE30004	KTG30003	KTG30004
375	220/240	S1			KTE30005	KTE30006	KTG30005	KTG30006
500	220/240	S1			KTE30007	KTE30008	KTG30007	KTG30008
750	220/240	S1			KTE30009	KTE30010	KTG30009	KTG30010
250	220/240	S1	9.75 247.7	7.38 187.3	KTE10001	KTE10002	KTG10002	KTG10003
400	220/240	S1			KTE10003	KTE10004	KTG10004	KTG10005
500	220/240	S1			KTE10005	KTE10006	KTG10006	KTG10007
650	220/240	S1			KTE10007	KTE10008	KTG10008	KTG10009
1000	220/240	S1			KTE10009	KTE10010	KTG10010	KTG10011
375	220/240	S1	14.63 371.5	12.25 311.2	KTE40001	KTE40002	KTG40001	KTG40002
600	220/240	S1			KTE40003	KTE40004	KTG40003	KTG40004
750	220/240	S1			KTE40005	KTE40006	KTG40005	KTG40006
1000	220/240	S1			KTE40007	KTE40008	KTG40007	KTG40008
1500	220/240	S1			KTE40009	KTE40010	KTG40009	KTG40010
500	220/240	S1	19.50 495.3	17.13 435.0	KTE50001	KTE50002	—	—
800	220/240	S1			KTE50003	KTE50004	—	—
1000	220/240	S1			KTE50005	KTE50006	—	—
1500	220/240	S1			KTE50007	KTE50008	—	—
2000	220/240	S1			KTE50009	KTE50010	—	—
250	220/240	S2	See Drawing		KTE60001	KTE60002	KTG60001	KTG60002
400	220/240	S2			KTE60003	KTE60004	KTG60003	KTG60004
500	220/240	S2			KTE60005	KTE60006	KTG60005	KTG60006
650	220/240	S2			KTE60007	KTE60008	KTG60007	KTG60008
1000	220/240	S2			KTE60009	KTE60010	KTG60009	KTG60010

Drawing S1 – Rectangular Heater

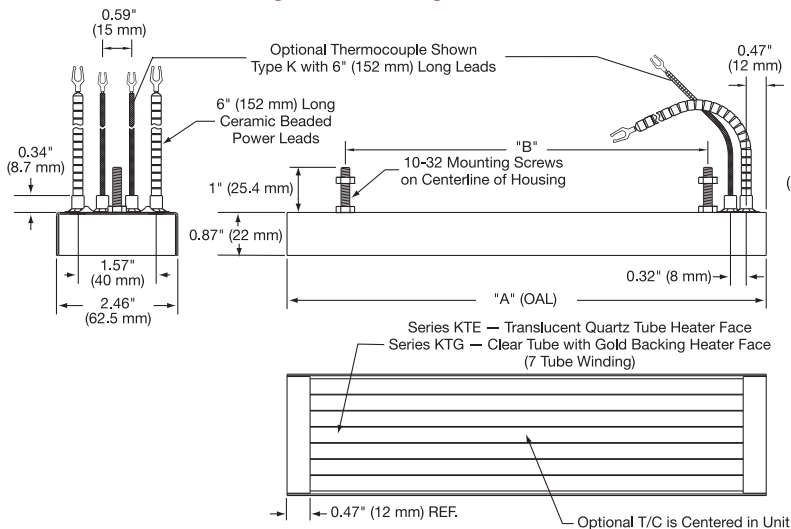

Drawing S2 – Square Heater

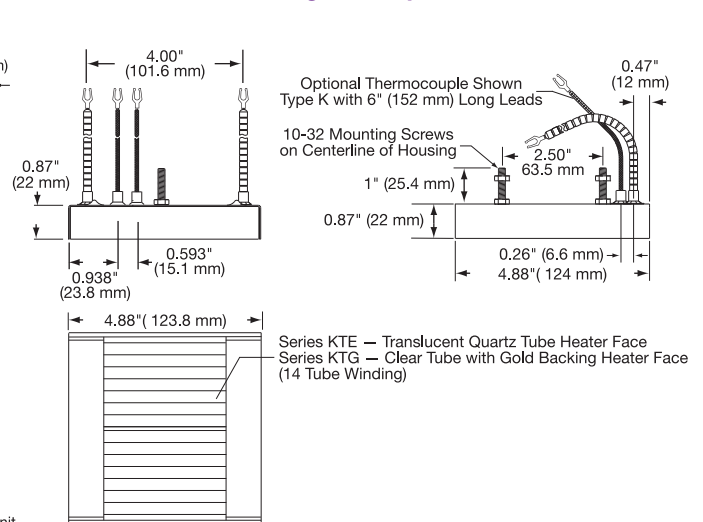

Radiant Process Heaters



KTE Heater Specifications

KTE1 Series – 9.75" × 2.46" Housing

KTE6 Series – 4.88" Square Housing

Watts/Square Inch vs. Temperature Data

Heater Wattage	Heater Face Watt Density*		Heater Body Temp @ 72°F**		Peak Emitted Wavelength*** (microns)	
	Style S	Style C	Style S	Style C	Style S	Style C
	150	8.30	7.12	608	554	4.89
163	9.02	7.73	638	583	4.75	5.00
200	11.07	9.49	714	656	4.44	4.67
250	13.84	11.86	798	740	4.15	4.35
300	16.60	14.23	868	809	3.93	4.11
325	17.99	15.42	898	839	3.84	4.01
350	19.37	16.60	926	868	3.76	3.93
400	22.14	18.98	978	918	3.63	3.78
500	27.67	23.72	1070	1006	3.41	3.56
600	33.20	28.46	1154	1083	3.23	3.38
650	35.97	30.83	1194	1119	3.15	3.30
700	38.74	33.21	1232	1154	3.08	3.23
750	41.51	35.58	1269	1188	3.02	3.16
800	44.27	37.95	1303	1222	2.96	3.10
875	48.42	41.51	1349	1269	2.88	3.02
900	49.81	42.69	1363	1284	2.86	2.99
1000	55.34	47.44	1411	1339	2.79	2.90

KTE2 Series – 4.88" × 2.46" Housing

Watts/Square Inch vs. Temperature Data

Heater Wattage	Heater Face Watt Density*		Heater Body Temp @ 72°F**		Peak Emitted Wavelength*** (microns)	
	Style S	Style C	Style S	Style C	Style S	Style C
	100	12.29	10.53	753	695	4.30
125	15.36	13.16	838	779	4.02	4.21
150	18.43	15.79	907	848	3.82	3.99
163	20.02	17.16	939	880	3.73	3.89
200	24.57	21.05	1020	959	3.52	3.68
250	30.71	26.32	1117	1049	3.31	3.46
300	36.86	31.58	1206	1130	3.13	3.28
325	39.93	34.21	1248	1169	3.05	3.20
350	43.00	36.84	1287	1206	2.99	3.13
400	49.14	42.11	1356	1276	2.87	3.00
500	61.43	52.63	1451	1389	2.73	2.82

KTE3 Series – 7.31" × 2.46" Housing

Watts/Square Inch vs. Temperature Data

Heater Wattage	Heater Face Watt Density*		Heater Body Temp @ 72°F**		Peak Emitted Wavelength*** (microns)	
	Style S	Style C	Style S	Style C	Style S	Style C
	100	7.63	6.54	578	526	5.02
125	9.54	8.18	658	602	4.66	4.91
150	11.45	9.81	726	669	4.40	4.62
163	12.44	10.66	758	700	4.28	4.50
200	15.27	13.08	836	777	4.03	4.22
250	19.08	16.35	921	862	3.78	3.95
300	22.90	19.62	992	931	3.59	3.75
325	24.81	21.26	1024	962	3.51	3.67
350	26.72	22.89	1055	992	3.44	3.59
400	30.53	26.16	1114	1046	3.31	3.46
500	38.17	32.70	1224	1147	3.10	3.25
600	45.80	39.24	1321	1239	2.93	3.07
650	49.62	42.51	1361	1281	2.86	3.00
700	53.44	45.78	1396	1320	2.81	2.93
750	57.25	49.05	1425	1355	2.77	2.87

KTE4 Series – 14.63" × 2.46" Housing

Watts/Square Inch vs. Temperature Data

Heater Wattage	Heater Face Watt Density*		Heater Body Temp @ 72°F**		Peak Emitted Wavelength*** (microns)	
	Style S	Style C	Style S	Style C	Style S	Style C
	200	7.63	6.54	578	526	5.02
250	9.54	8.18	658	602	4.66	4.91
300	11.45	9.81	726	669	4.40	4.62
375	14.31	12.26	811	752	4.10	4.30
400	15.27	13.08	836	777	4.03	4.22
500	19.08	16.35	921	862	3.78	3.95
600	22.90	19.62	992	931	3.59	3.75
750	28.63	24.53	1085	1019	3.38	3.53
800	30.53	26.16	1114	1046	3.31	3.46
900	34.35	29.43	1171	1098	3.20	3.35
1000	38.17	32.70	1224	1147	3.10	3.25
1250	47.71	40.88	1341	1261	2.90	3.03
1500	57.25	49.05	1425	1355	2.77	2.87

KTE5 Series – 19.50" × 2.46" Housing Watts/Square Inch vs. Temperature Data

Heater Wattage	Heater Face Watt Density*		Heater Body Temp @ 72°F**		Peak Emitted Wavelength*** (microns)	
	Style S	Style C	Style S	Style C	Style S	Style C
250	7.16	6.13	556	505	5.14	5.41
300	8.59	7.36	620	565	4.83	5.09
375	10.73	9.20	702	645	4.49	4.72
400	11.45	9.81	726	669	4.40	4.62
500	14.31	12.26	811	752	4.10	4.30
600	17.17	14.71	880	822	3.89	4.07
750	21.47	18.39	966	907	3.66	3.82
800	22.90	19.62	992	931	3.59	3.75
900	25.76	22.07	1040	977	3.48	3.63
1000	28.62	24.52	1085	1019	3.38	3.53
1250	35.78	30.65	1191	1116	3.16	3.31
1500	42.93	36.78	1287	1205	2.99	3.13
1650	47.22	40.46	1336	1255	2.90	3.04
1700	48.65	41.69	1351	1271	2.88	3.01
1750	50.09	42.91	1366	1286	2.86	2.99
1800	51.52	44.14	1379	1301	2.84	2.96
1900	54.38	46.59	1403	1329	2.80	2.92
2000	57.24	49.04	1425	1355	2.77	2.87

*Heater Face Watt Density

Watt density calculation is based on heater face surface area, which is a relative constant value used to relate different sizes of heaters. The 6 tube KTE (Style S) has a surface area 85.7% of a 7 tube unit (Style C) and will operate at a temperature 16.6% higher than the 7 tube (Style C) unit. This relationship has been confirmed through laboratory testing on various sizes of KTE heaters.

**Heater Body Temp @ 72°F

Heater face temperature as measured with a type K thermocouple mounted directly on the heater face. Temperatures are for a single heater facing down with target re-radiation from an oxidized SS surface 3" from heater face. Operating temperatures (and emitted wavelength) will vary with application conditions such as higher ambient, target absorption properties, moving/stationary systems, and distance to target. The tabulated temperatures are averages compiled from standardized lab tests on different ratings and sizes of KTE heaters. Translucent tube testing showed that various reflector materials and surface conditions (bright, oxidized, etc.) had little or no effect on test results. Lower heater temperatures will occur if radiation is allowed to dissipate freely from the surface without target re-radiation (about 20-25% lower when facing up in open air).

***Peak Emitted Wavelength

Peak infrared radiation wavelength as calculated from Wien's Displacement Law, for the operating temperature shown, expressed in microns (μm). The emissivity of KTE quartz heaters is close to the ideal blackbody value of 1.0 (range is from .88 to .92). This has been confirmed by testing using a thermal infrared camera.

Custom CRA Linear Heater Assemblies for KTE and KTG E-Mitters Using Standard Components

Do It Yourself or let Tempco build an array to your exact specifications.

The CRK Linear Housings assembly (page 7-19) and other components on pages 7-16 through 7-23 for Ceramic E-Mitters are also used with KTE and KTG E-Mitters.

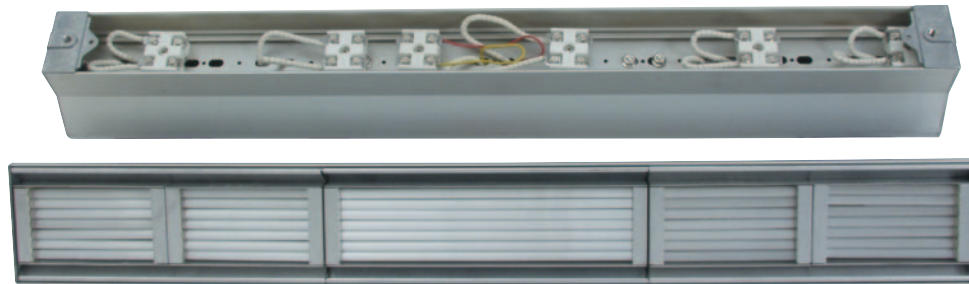

Custom ARV Array Housing Assemblies for KTE and KTG E-Mitters (see pages 7-48 through 7-51)

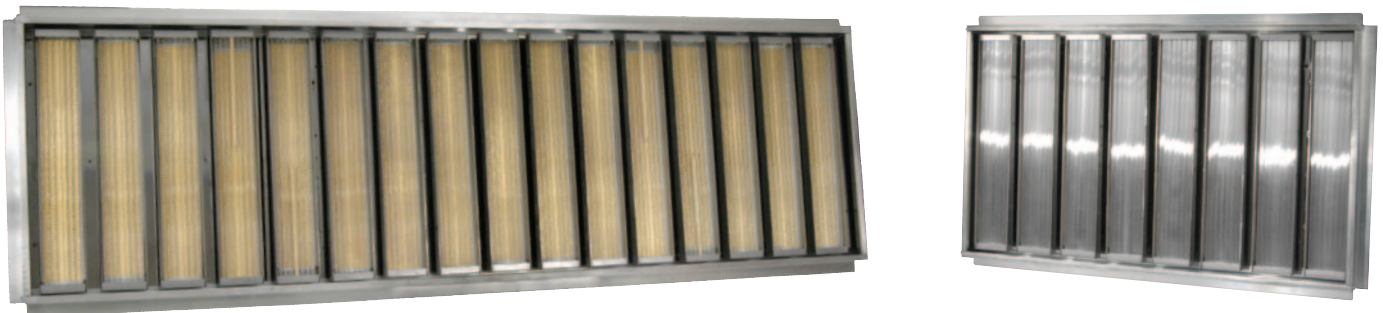

Series KTE1 E-Mitter Panel Arrays Standard Style ARV Structural Housing Dimensions

- A) The Number of Rows will determine the Housing Width. For overall width add 1.50" (for the mounting lips).
B) The Number of Columns will determine the Housing Length. For overall length add 1.50" (for the mounting lips).



Note: Structural Housing Dimensions (width x length) are in inches. For overall dimensions add 0.75" per side for the mounting lip.

Number of Rows	Number of Columns					
	1 W x L	2 W x L	3 W x L	4 W x L	5 W x L	6 W x L
1	4 x 11	4 x 21	4 x 31	4 x 41	4 x 51	4 x 61
1	4 x 11	4 x 21	4 x 31	4 x 41	4 x 51	4 x 61
2	7 x 11	7 x 21	7 x 31	7 x 41	7 x 51	7 x 61
3	10 x 11	10 x 21	10 x 31	10 x 41	10 x 51	10 x 61
4	13 x 11	13 x 21	13 x 31	13 x 41	13 x 51	13 x 61
5	16 x 11	16 x 21	16 x 31	16 x 41	16 x 51	16 x 61
6	19 x 11	19 x 21	19 x 31	19 x 41	19 x 51	19 x 61
7	22 x 11	22 x 21	22 x 31	22 x 41	22 x 51	22 x 61
8	25 x 11	25 x 21	25 x 31	25 x 41	25 x 51	25 x 61
9	28 x 11	28 x 21	28 x 31	28 x 41	28 x 51	—
10	31 x 11	31 x 21	31 x 31	31 x 41	—	—
11	34 x 11	34 x 21	34 x 31	34 x 41	—	—
12	37 x 11	37 x 21	37 x 31	37 x 41	—	—
13	40 x 11	40 x 21	40 x 31	—	—	—
14	43 x 11	43 x 21	43 x 31	—	—	—
15	46 x 11	46 x 21	46 x 31	—	—	—
16	49 x 11	49 x 21	—	—	—	—
17	52 x 11	52 x 21	—	—	—	—
18	55 x 11	55 x 21	—	—	—	—

Dimensions are in inches

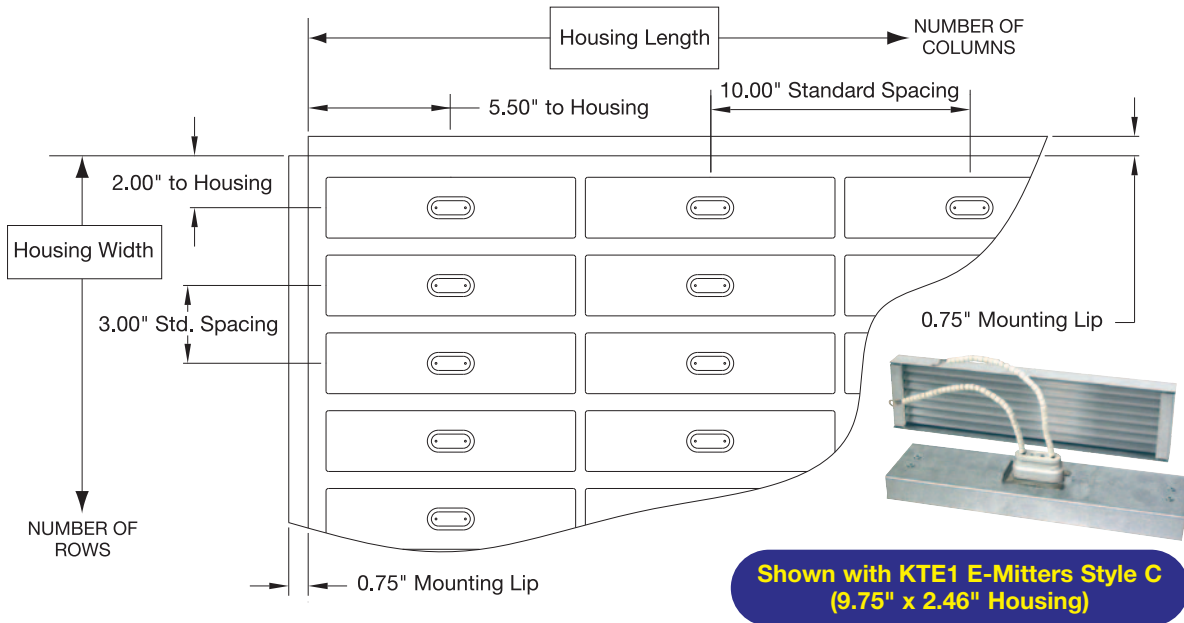

Custom Engineered/Manufactured Panels

- Multiple panels are used for larger arrays. Custom panels with other spacings are available.
- Minimum spacing for KTE1 heaters is 3.00" x 10.00". Special narrow panels having a maximum 40 rows x 1 or 2 columns, and up to 8 rows x 12 columns can be made on special order (max. housing size 121" x 25").
- Consult factory for larger panels not shown in table. Array panels can be adapted for either the 10-32 stud mount or ceramic heater style heaters. Specify heater mounting type when ordering (C or S style).

**Consult us with your requirements.
There is no substitute for experience.**

WARNING: Cancer and Reproductive Harm - www.P65Warnings.ca.gov.



Series KTE2 E-Mitter Panel Arrays Standard Style ARV Structural Housing Dimensions

- A) The Number of Rows will determine the Housing Width. For overall width add 1.50" (for the mounting lips).
 B) The Number of Columns will determine the Housing Length. For overall length add 1.50" (for the mounting lips).

Number of Rows	Number of Columns											
	1 W x L	2 W x L	3 W x L	4 W x L	5 W x L	6 W x L	7 W x L	8 W x L	9 W x L	10 W x L	11 W x L	12 W x L
1	4 x 6	4 x 11	4 x 16	4 x 21	4 x 26	4 x 31	4 x 36	4 x 41	4 x 46	4 x 51	4 x 56	4 x 61
2	7 x 6	7 x 11	7 x 16	7 x 21	7 x 26	7 x 31	7 x 36	7 x 41	7 x 46	7 x 51	7 x 56	7 x 61
3	10 x 6	10 x 11	10 x 16	10 x 21	10 x 26	10 x 31	10 x 36	10 x 41	10 x 46	10 x 51	10 x 56	10 x 61
4	13 x 6	13 x 11	13 x 16	13 x 21	13 x 26	13 x 31	13 x 36	13 x 41	13 x 46	13 x 51	13 x 56	13 x 61
5	16 x 6	16 x 11	16 x 16	16 x 21	16 x 26	16 x 31	16 x 36	16 x 41	16 x 46	16 x 51	16 x 56	16 x 61
6	19 x 6	19 x 11	19 x 16	19 x 21	19 x 26	19 x 31	19 x 36	19 x 41	19 x 46	19 x 51	19 x 56	19 x 61
7	22 x 6	22 x 11	22 x 16	22 x 21	22 x 26	22 x 31	22 x 36	22 x 41	22 x 46	22 x 51	22 x 56	22 x 61
8	25 x 6	25 x 11	25 x 16	25 x 21	25 x 26	25 x 31	25 x 36	25 x 41	25 x 46	25 x 51	25 x 56	25 x 61
9	28 x 6	28 x 11	28 x 16	28 x 21	28 x 26	28 x 31	28 x 36	28 x 41	28 x 46	28 x 51	—	—
10	31 x 6	31 x 11	31 x 16	31 x 21	31 x 26	31 x 31	31 x 36	31 x 41	—	—	—	—
11	34 x 6	34 x 11	34 x 16	34 x 21	34 x 26	34 x 31	34 x 36	34 x 41	—	—	—	—
12	37 x 6	37 x 11	37 x 16	37 x 21	37 x 26	37 x 31	37 x 36	37 x 41	—	—	—	—
13	40 x 6	40 x 11	40 x 16	40 x 21	40 x 26	40 x 31	—	—	—	—	—	—
14	43 x 6	43 x 11	43 x 16	43 x 21	43 x 26	43 x 31	—	—	Dimensions are in inches			—
15	46 x 6	46 x 11	46 x 16	46 x 21	46 x 26	46 x 31	—	—				—
16	49 x 6	49 x 11	49 x 16	49 x 21	—	—	—	—	—	—	—	—
17	52 x 6	52 x 11	52 x 16	52 x 21	—	—	—	—	—	—	—	—
18	55 x 6	55 x 11	55 x 16	55 x 21	—	—	—	—	—	—	—	—



Note: Structural Housing Dimensions (width x length) are in inches. For overall dimensions add 0.75" per side for the mounting lip.

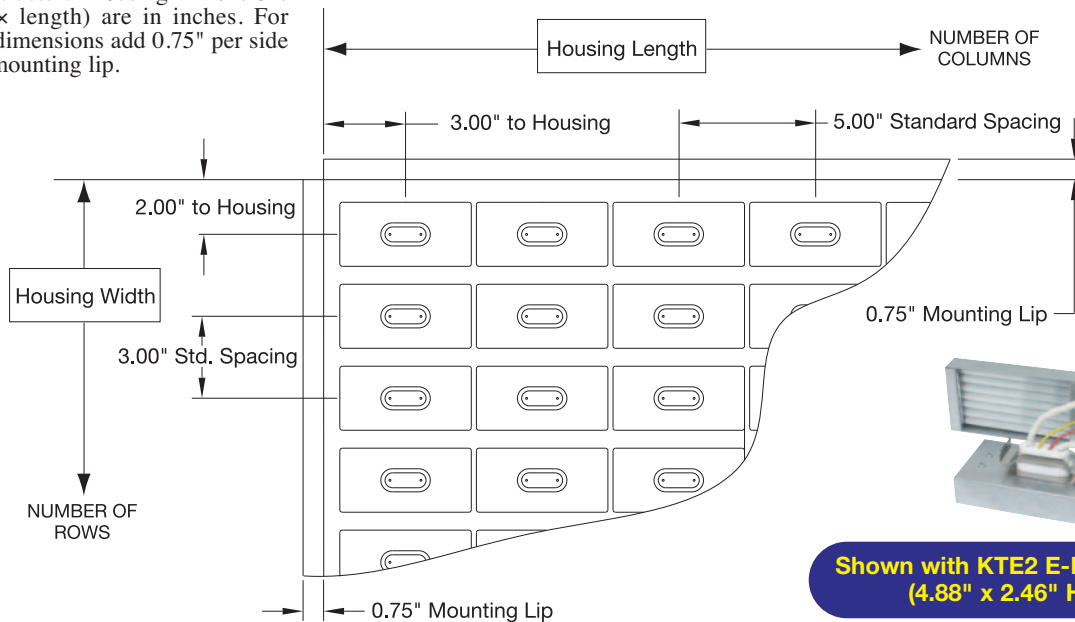

Shown with KTE2 E-Mitters Style C (4.88" x 2.46" Housing)

Custom Engineered/Manufactured Panels

- Multiple panels are used for larger arrays. Standard single panel construction is not offered beyond limits shown. Custom panels with other spacings are available.
- Minimum spacing for KTE2 heaters is 3.00" x 5.00". Special narrow panels having a maximum 40 rows x 1, 2, 3, or 4 columns, and up to 8 rows x 24 columns can be made on special order (max. housing size 121" x 25").
- Consult factory for larger panels not shown in table. Array panels can be adapted for either the 10-32 stud mount or ceramic heater style heaters. Specify heater mounting type when ordering (C or S style).

**Consult us with your requirements.
There is no substitute for experience.**

WARNING: Cancer and Reproductive Harm - www.P65Warnings.ca.gov.

Series KTE6 and KTG6 E-Mitter Panel Arrays Standard Style ARV Structural Housing Dimensions

- A) The Number of Rows will determine the Housing Width. For overall width add 1.50" (for the mounting lips).
B) The Number of Columns will determine the Housing Length. For overall length add 1.50" (for the mounting lips).

Number of Rows	Number of Columns											
	1 W x L	2 W x L	3 W x L	4 W x L	5 W x L	6 W x L	7 W x L	8 W x L	9 W x L	10 W x L	11 W x L	12 W x L
1	6 x 6	6 x 11	6 x 16	6 x 21	6 x 26	6 x 31	6 x 36	6 x 41	6 x 46	6 x 51	6 x 56	6 x 61
2	11 x 6	11 x 11	11 x 16	11 x 21	11 x 26	11 x 31	11 x 36	11 x 41	11 x 46	11 x 51	11 x 56	11 x 61
3	16 x 6	16 x 11	16 x 16	16 x 21	16 x 26	16 x 31	16 x 36	16 x 41	16 x 46	16 x 51	16 x 56	16 x 61
4	21 x 6	21 x 11	21 x 16	21 x 21	21 x 26	21 x 31	21 x 36	21 x 41	21 x 46	21 x 51	21 x 56	21 x 61
5	26 x 6	26 x 11	26 x 16	26 x 21	26 x 26	26 x 31	26 x 36	26 x 41	26 x 46	26 x 51	26 x 56	26 x 61
6	31 x 6	31 x 11	31 x 16	31 x 21	31 x 26	31 x 31	31 x 36	31 x 41	31 x 46	31 x 51	—	—
7	36 x 6	36 x 11	36 x 16	36 x 21	36 x 26	36 x 31	36 x 36	36 x 41	36 x 46	—	—	—
8	41 x 6	41 x 11	41 x 16	41 x 21	41 x 26	41 x 31	41 x 36	41 x 41	—	—	—	—
9	46 x 6	46 x 11	46 x 16	46 x 21	46 x 26	46 x 31	46 x 36	—	—	Dimensions are in inches		
10	51 x 6	51 x 11	51 x 16	51 x 21	51 x 26	51 x 31	—	—				
11	56 x 6	56 x 11	56 x 16	56 x 21	56 x 26	—	—	—	—	—	—	—
12	61 x 6	61 x 11	61 x 16	61 x 21	61 x 26	—	—	—	—	—	—	—



Note: Structural Housing Dimensions (width x length) are in inches. For overall dimensions add 0.75" per side for the mounting lip.

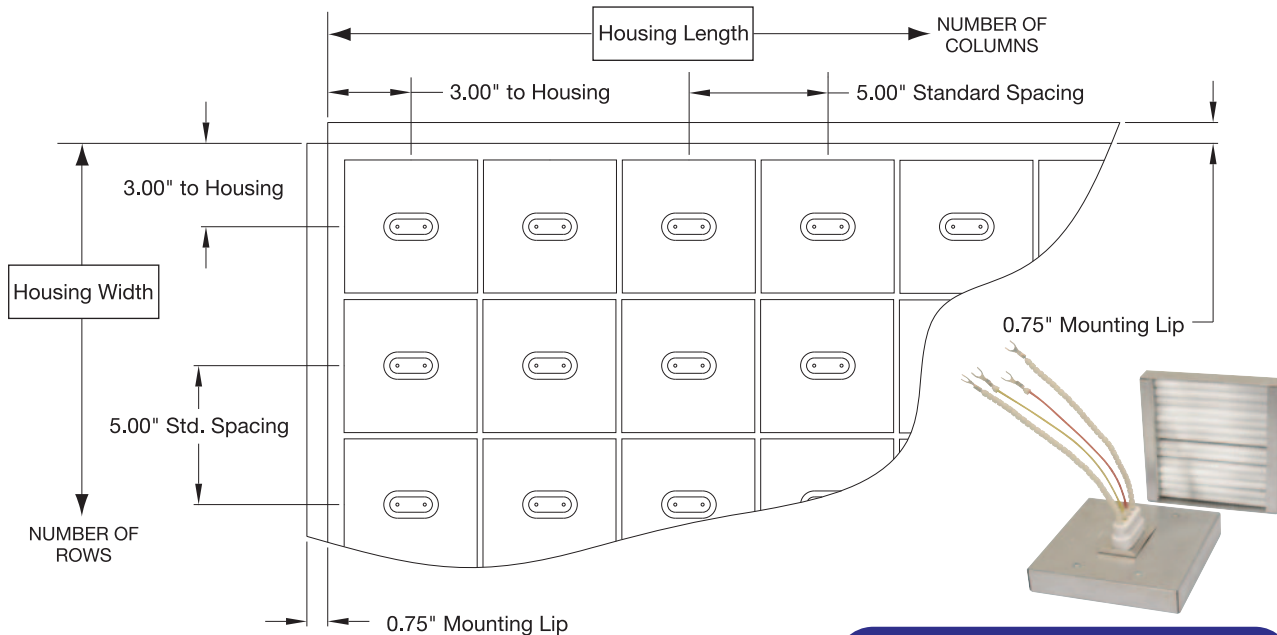

Shown with KTE6 E-Mitters Style C (4.88" x 4.88" Housing)

Custom Engineered/Manufactured Panels

- Multiple panels are used for larger arrays. Standard single panel construction is not offered beyond limits shown. Custom panels with other spacings are available.
- Minimum spacing for KTE6 heaters is 5.00" x 5.00". Special narrow panels having a maximum 25 rows x 1, or 2 columns, and up to 8 rows x 9 columns can be made on special order (max. housing size 121" x 25").
- Consult factory for larger panels not shown in table. Array panels can be adapted for either the 10-32 stud mount or ceramic heater style heaters. Specify heater mounting type when ordering (C or S style).

**Consult us with your requirements.
There is no substitute for experience.**

WARNING: Cancer and Reproductive Harm - www.P65Warnings.ca.gov.



ARV Array Panel Design Worksheet for Quartz Mini-Tube E-Mitters

Ordering Information

To process your order please specify the following information.

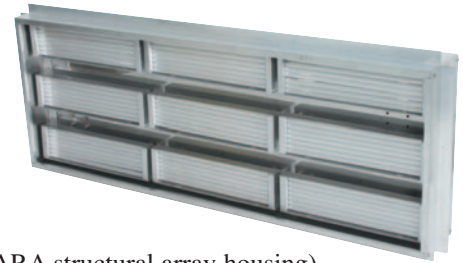

1.) Supply panel layout or sketch showing:

- Outside panel dimensions (allow for 0.75" wide mounting lip on all sides of ARA structural array housing)
- Heater type and orientation of long (or short) heater dimension
- Layout of rows and columns with number of heaters
- Spacing of rows and columns (Tempco will use standard spacing unless specified by customer)
- Zones and/or number of heaters per zone
- Locations of input wiring
- Locations of heaters with thermocouples (if used)

2.) Electrical requirements:

- Total panel KW _____
- Zone KWs (or # of heaters in zones) _____
- Line voltage to panel, # of circuits, & 1 or 3 phase operation _____
- If 480V, can series-parallel wiring and 240V heaters be used? _____
- Type of heater control to be used _____

3.) Heater Specifications:

- Heater Type KTE KTG
- Heater Size KTE1 (9-3/4"L) KTE2 (4-7/8"L) KTE3 (7-5/16"L) KTE4 (14-5/8"L) KTE5 (19-1/2"L)
 KTE6 (4-7/8" Sq.)
- Heater Mounting Style C S
- Catalog Part Number _____ or Watts _____ Volts _____
- Standard K thermocouple or optional J _____ Quantity _____
- Heater lead configuration — Standard is 3.5" or 6" with spade terminal
Spade terminals used if factory wired (ring terminals optional) _____
- Special marking if required _____

4.) Panel wiring & control options:

- Standard unit wiring is heaters to terminal blocks only
- Factory wired per customer specs & wiring diagram
- Tempco Engineering to design internal wiring & determine line input requirements
- Tempco to supply turnkey power control panel(s)

5.) Any special features required? _____

6.) Application Data:

- Type of application and physical properties of processed materials _____

⚠ WARNING: Cancer and Reproductive Harm - www.P65Warnings.ca.gov.

(800) 323-6859 • Email: sales@tempco.com

Sealed IR Quartz Lamps



Design Features

- * *Fast Filament Response*
- * *High Power Densities possible — up to 200 watts per inch per filament*
- * *Different filament temperatures available to suit different materials*
- * *Optional white or gold reflective layer on lamps redirects heat towards target material*
- * *Single or twin-tube construction*
- * *Contour bending available*

Filament Temperature Ratings

Filament Type	Near Infrared (NIR)	Short Wave (SW)	Fast Response Medium Wave (FRMW) High Temperature	Fast Response Medium Wave (FRMW) Low Temperature
Filament Response	1 second	1 second	1-2 seconds	1-2 seconds
Filament Temperature	2900K/4800°F	2500K/4000°F	1900K/2900°F	1500K/2200°F
Approximate Peak Wavelength	1.0μm	1.2μm	1.6μm	2.0μm
Maximum watts/inch per Filament	200	200	100	100
Average Lifetime (Hours)	2000	5000	5000	5000

SPECIFICATIONS

- Max. Temperature:** 350°C — End Seal
 900°C — Quartz Tube and optional White Ceramic Reflective Layer
 800°C — Optional Gold Reflective Layer
- Max. Voltage:** 600 Volts depending on design

LAMP GLASS TYPES

- Clear:** Standard
- Ruby:** Reduces Glare
- Translucent:** Reduces Glare
- Frosted:** Reduces Glare
- Gold Reflector:** Redirects heat toward target for increased efficiency.
- White Reflector:** Redirects heat toward target for increased efficiency similar to gold, but will not degrade over time at high temperatures.



Custom Designs

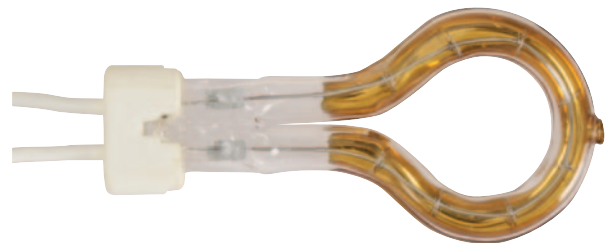

Lamp Terminations

Select the termination style that meets your requirements.

Type R7s Recessed Single Contact



Minimum Unheated Length

1.12"
Standard



Type R7W R7S + Lead Wire



1.12"



Type F Flat Ceramic + Lead Wire (No Cement)

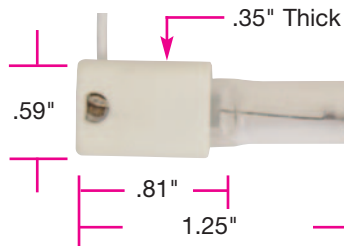

Type FX Flat Ceramic + Lead Wire (Fixed with Cement)

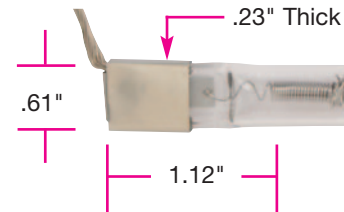

TYPE U Metal Clip + Lead Wire

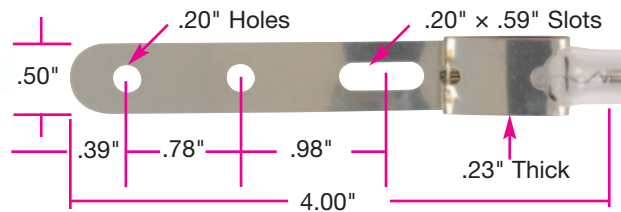

Type X Metal Tabs with Mounting Holes & Slots



Type W Lead Wire Only (Bare Wire Shown)



1.00"



Type RC Round Ceramic



1.12"



Radiant Process Heaters



Sealed IR Quartz Lamps

Common Industry Standard (Non-Stock) Lamps

Filament color temperature is 2500K and lead wire terminations have 145 mm (5-11/16") of uninsulated wire unless otherwise noted.

Wattage	Voltage	Overall Length		Heated Length		Base Type	Burning	Glass Type	Special Notes	Part Number
		(in)	(mm)	(in)	(mm)					
300	120	8.46	215.0	4.17	106.0	U	V	Clear		LMP00001
300	120	8.43	214.0	4.17	106.0	U	H	Translucent		LMP00002
375	120	8.69	220.6	5.06	128.6	R7s	V	Clear		LMP00003
500	120	8.50	216.0	5.06	128.6	R7s	H	Frosted		LMP00004
500	120	8.66	220.0	5.00	127.0	R7s	H	Translucent		LMP00005
500	120	8.69	220.6	4.84	123.0	R7s	V	Clear		LMP00006
500	120	8.81	223.8	4.84	123.0	U	H	Clear		LMP00007
500	240	8.69	220.6	5.06	128.6	R7W	H	Clear		LMP00008
500	240	8.96	227.5	6.50	165.0	Fx	H	Clear	Teflon® Insulated Lead Wire (with #10 Spade Terminal)	LMP00009
1000	208	13.63	346.2	10.06	255.5	R7s	H	Clear		LMP00010
1000	240	11.93	303.0	10.00	254.0	U	V	Clear		LMP00011
1000	240	13.63	346.2	10.06	255.5	R7s	H	Clear		LMP00012
1000	240	13.81	350.8	10.00	254.0	U	V	Clear		LMP00013
1000	240	13.82	351.0	10.71	272.0	U	H	Translucent		LMP00014
1000	235	13.98	355.0	11.02	280.0	F	V	White Reflector	Teflon® Insulated Lead Wire (with M4 Spade Terminal) Lead Length: 9in (230mm)	LMP00015
1000	240	19.09	485.0	10.71	272.0	X	H	White Reflector		LMP00016
1000	277	13.63	346.2	10.06	255.5	R7s	H	Clear		LMP00017
1200	144	8.81	223.8	6.18	157.0	U	V	Clear		LMP00018
1200	240	18.07	459.0	15.20	386.0	R7s	V	Clear		LMP00019
1350	115	12.48	317.0	10.08	256.0	RC	H	Clear	2750K Color Temperature	LMP00020
1500	240	9.13	232.0	6.89	175.0	W	H	Clear	228 mm (9") Bare Lead Wire	LMP00021
1600	208	19.65	499.0	16.02	407.0	R7s	H	Translucent		LMP00022
1600	208	19.76	502.0	16.02	407.0	RC	H	Clear		LMP00023
1600	208	19.80	503.0	16.02	407.0	U	H	Translucent		LMP00024
1600	240	19.63	498.6	16.06	407.9	R7s	H	Clear		LMP00025
1600	240	19.80	503.0	16.02	407.0	U	H	Translucent		LMP00026
1600	240	19.81	503.2	15.75	400.0	U	V	Clear		LMP00027
1600	277	19.65	499.0	16.02	407.0	R7s	V	Clear		LMP00028
1600	277	19.81	503.2	16.02	407.0	U	V	Clear		LMP00029
2000	230	21.67	550.4	19.57	497.0	R7s	H	Clear		LMP00030
2000	240	13.78	350.0	11.73	298.0	R7s	H	Clear		LMP00031
2000	240	13.82	351.0	10.00	254.0	U	H	Clear		LMP00032
2000	240	13.74	349.0	11.02	280.0	W	V	Clear	#10 Ring Terminal	LMP00033
2000	240	13.86	352.0	11.50	292.0	W	H	Clear	228 mm (9") Bare Lead Wire	LMP00034
2000	240	13.94	354.0	11.42	290.0	Fx	H	White Reflector		LMP00035
2000	240	14.06	357.0	11.02	280.0	Fx	V	White Reflector	Teflon® Insulated Lead Wire (with #10 Spade Terminal)	LMP00036
2000	240	19.09	485.0	11.02	280.0	X	V	Clear		LMP00037
2000	400	24.53	623.0	16.14	410.0	X	V	Clear		LMP00038
2500	240	13.86	352.0	11.50	292.0	W	H	Clear	228 mm (9") Bare Lead Wire	LMP00039
2500	400	14.06	357.0	11.02	280.0	F	H	White Reflector	Teflon® Insulated Lead Wire (with #10 Spade Terminal)	LMP00040
2500	480	28.62	727.0	25.00	635.0	R7s	H	Translucent		LMP00041
2500	480	28.63	727.2	25.06	636.5	R7s	V	Clear		LMP00042
2500	480	28.78	731.0	25.00	635.0	RC	H	Clear		LMP00043
2500	480	28.81	731.8	24.87	631.8	U	V	Clear		LMP00044
2500	480	28.82	732.0	25.00	635.0	U	H	Translucent		LMP00045
2500	575	28.82	732.0	25.00	635.0	U	H	Clear		LMP00046
2500	600	28.78	731.0	25.00	635.0	RC	V	Clear		LMP00047
3000	400	35.94	913.0	27.56	700.0	X	H	Clear		LMP00048
3650	480	41.69	1059.0	37.99	965.0	U	V	Clear		LMP00049
3650	480	41.81	1062.0	37.72	958.0	RC	H	Clear		LMP00050
3800	570	41.81	1062.0	37.99	965.0	U	V	Clear		LMP00051
3800	570	41.81	1062.0	37.99	965.0	RC	V	Clear		LMP00052
3800	575	40.63	1032.0	37.06	941.3	R7s	H	Clear		LMP00053
4900	480	52.81	1341.3	49.02	1245.0	RC	V	Clear		LMP00054

Terminations Key

F — Flat ceramic (no cement)
Fx — Flat ceramic (fixed with cement)
U — Metal sleeve + wire
X — Metal tab w/holes & slot
R7s — Recessed single contact

R7W — R7s w/lead wire

RC — Round ceramic + lead wire
W — Lead wire only - no base

Burning Positions Key

H — Horizontal use only
V — Horizontal or vertical use



Worksheet for Sealed IR Quartz Lamps

Ordering Information

To process your order please specify the following information.

1.) Heater Specifications:

- Filament Temperature: Standard FRMW = 1500K High Temperature FRMW = 1900K
 Standard Halogen = 2500K NIR Halogen = 2900K Other _____
- Tube Cross Section: Single Round Tube Twin Bore Tube
- Tube Shape Straight Special Bend Configuration
- Tube Color: Clear (Standard) Ruby Translucent Frosted Ruby Frosted (Sandblasted) Clear
- Maximum Overall Length (Inches) _____
- Heated Length (Inches) _____
- Built-In Reflector: No Reflector White Reflector Gold Reflector

2.) Electrical requirements:

- Voltage: 120 240 277 480 Other _____
- Wattage _____

3.) Termination Types:

- Single Tube Bases R7s R7W RC X F FX U Other _____
- Twin Tube Bases Ceramic with straight exit leads (Standard) Other _____
- Lead Wire Type Bare Wire (Standard) Teflon®@200°C Fiberglass@250°C Mica@450°C
- Lead Length 5.7" (Standard)_____ (Note: Type R7s and X do not have leads)
- Terminal Options None (Standard) #10 Ring Terminal #10 Spade Terminal Other _____

4.) Panel wiring & control options:

- Tempco to supply array panel
- Factory wired per customer specs & wiring diagram
- Tempco Engineering to design internal wiring & determine line input requirements
- Tempco to supply turnkey power control panel(s)

5.) Any special features required? _____

6.) Application Data:

Type of application and physical properties of processed materials

 **WARNING:** Cancer and Reproductive Harm - www.P65Warnings.ca.gov.

(800) 323-6859 • Email: sales@tempco.com

Standard Double-End Wiring

NOTE:
Allow for element movement when wiring inside this end.

Attach properly rated line input wires to both element ends using the nickel-plated steel ring crimp connectors provided. Solid or stranded conductors can be used.

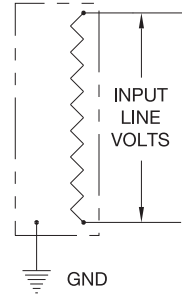
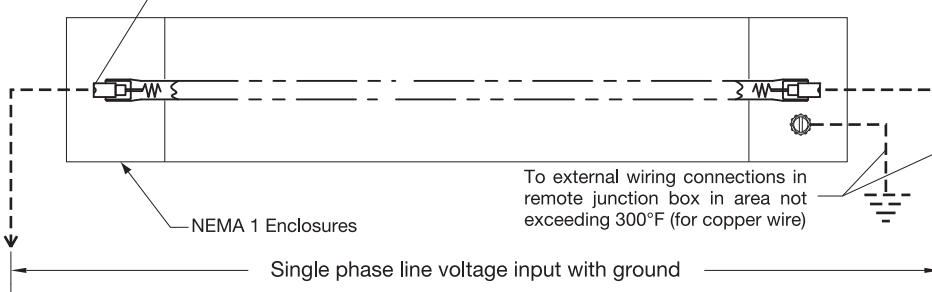

Optional Single End-Wiring

Single return wire rated for 842°F (450°C), 600V is supplied in internal wireway for line input at ground lug end.

External wiring connection in remote junction box in area not exceeding 300°F (for copper wire)

CAUTION: Do not cut or connect to this wire inside QRH housing. For connection to field wiring within external junction box only.

Wireway conductor extends 12" from unit

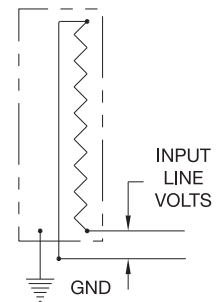
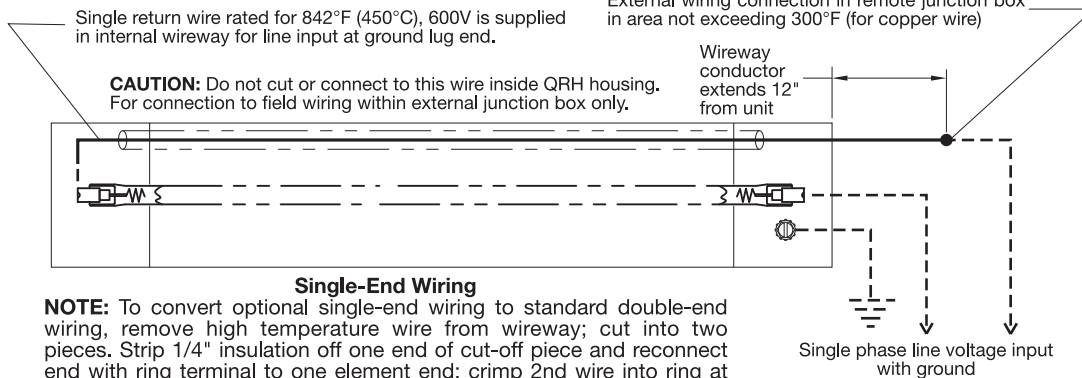

Single-End Wiring

NOTE: To convert optional single-end wiring to standard double-end wiring, remove high temperature wire from wireway; cut into two pieces. Strip 1/4" insulation off one end of cut-off piece and reconnect end with ring terminal to one element end; crimp 2nd wire into ring at opposite element end.

Lamp Accessories

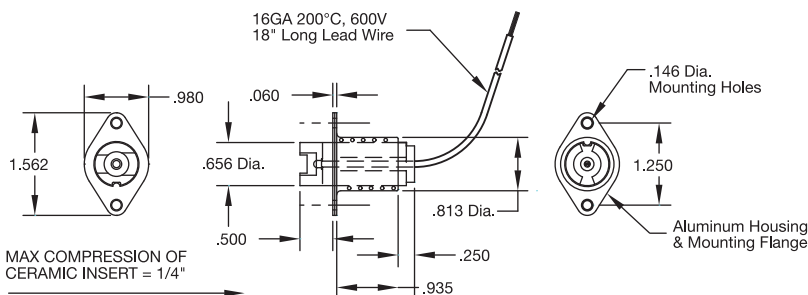
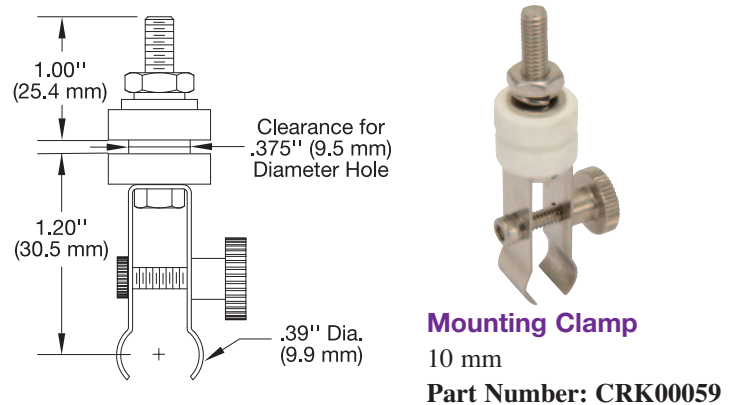
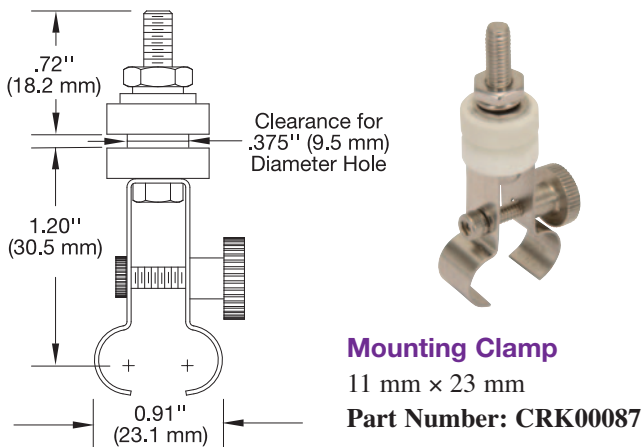

Mounting Clamp

Used for mounting & wiring lamps with R7s termination. 600 volts maximum. 350°C maximum operating temperature.

Part Number: LMP-103-101

Wiring Options

Series QRH Heaters can be prewired with plain leads, stainless steel armor cable, galvanized armor cable, stainless steel wire braid or SJO cable. For additional information See Wiring Options on page 7-17.

VIRTUAL SOLAR **GLOW**® *Infrared Heaters*

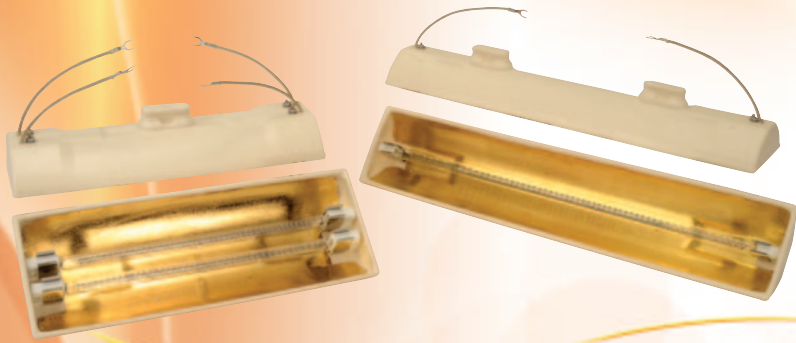

Series VSA

- *Short Wave IR*
- *2500K Filament Temperature*
- *Tungsten in Halogen-Filled Lamp*
- *150 – 2500 Watts*
- *See Page 7-59*



Series VSC

- *Medium Wave IR*
- *1500K Filament Temperature*
- *Star-Wound Tungsten in Evacuated Lamp*
- *75 – 1300 Watts*
- *See Page 7-60*

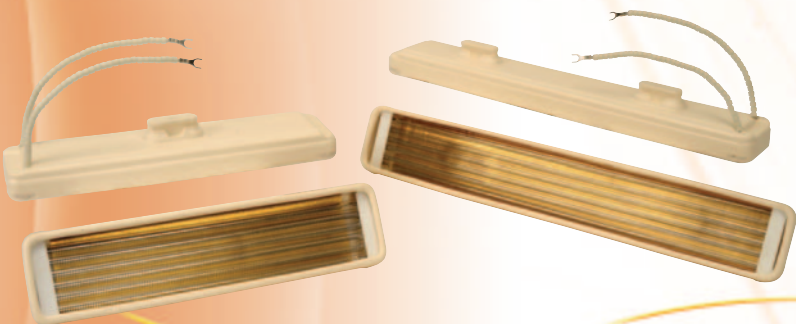

Series VSR

- *Medium Wave IR*
- *950K Wire Temperature*
- *Fe-Cr-Al Resistance Wire in Air*
- *125 – 1500 Watts*
- *See Page 7-61*

***VS Glow Is the Newest and Most Technically Advanced
Infrared Heater that Generates Instantaneous Heat***

VSA Series High Density Short Wave



Design Features

- * Gold Coated Ceramic Reflector
- * Short Wave Infrared Radiation up to 220 watts per linear inch
- * Fast Response, Immediate ON/OFF, Time: 20-40 seconds for full heat-up
- * All Ceramic Housing Construction
- * Standard Lamp Voltages: 120 & 230/240
- * All units are double-ended construction

Typical Semiconductor Industry Applications

- ↔ Etching ↔ Rapid Thermal Process ↔ Strip Removal
- ↔ Epitaxy ↔ Chemical Vapor Deposit

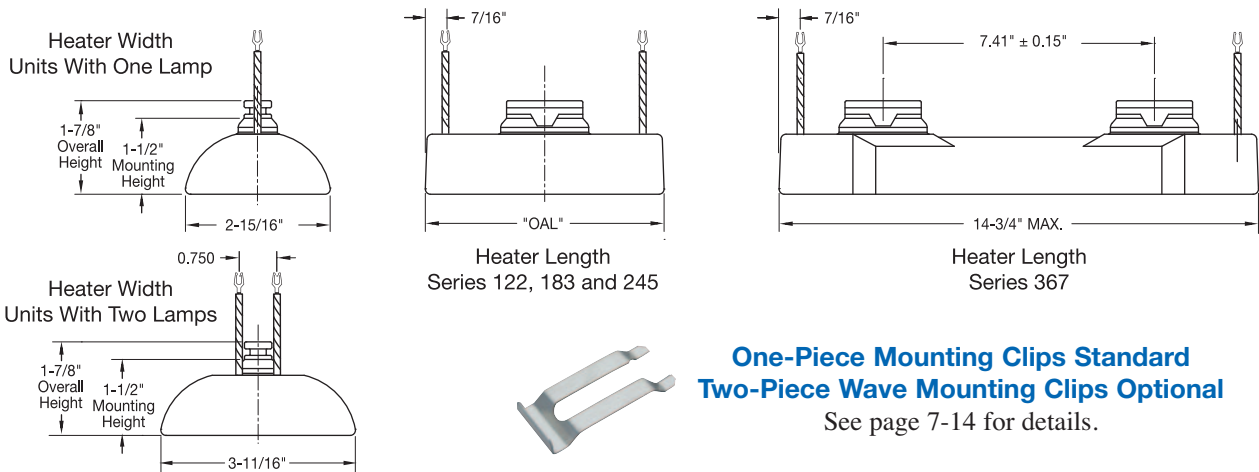

One-Piece Mounting Clips Standard
Two-Piece Wave Mounting Clips Optional

See page 7-14 for details.

Standard (Non-Stock) VSA Series

VS Glow heaters listed have 10" mica insulated leads and a one-piece spring clip for mounting.

Series	Maximum Overall Length		Heated Length		Wattage	Voltage	Part Number	Number of Lamps	Replacement Lamp Part Number
	(in)	(mm)	(in)	(mm)					
122	4.90	124.5	1.77	45	150	120	VSA00322	1	LMP00056
					225	120	VSA00323	1	LMP00057
					275	120	VSA00324	1	LMP00058
					450	120	VSA00325	2	LMP00057
183	7.36	187.0	4.17	106	300	120	VSA00326	1	LMP00059
					475	120	VSA00327	1	LMP00060
					600	120	VSA00328	1	LMP00061
					950	120	VSA00329	2	LMP00060
245	9.82	249.5	6.65	168	500	120	VSA00330	1	LMP00062
					750	120	VSA00331	1	LMP00063
					1000	120	VSA00332	1	LMP00064
					1500	120	VSA00333	2	LMP00063
					500	230/240	VSA00334	1	LMP00065
					750	230/240	VSA00335	1	LMP00066
					1000	230/240	VSA00336	1	LMP00067
367	14.74	374.5	11.38	289	1500	230/240	VSA00337	2	LMP00066
					800	120	VSA00338	1	LMP00068
					1250	120	VSA00339	1	LMP00069
					1500	120	VSA00340	1	LMP00070
					2500	120	VSA00341	2	LMP00069
					800	230/240	VSA00342	1	LMP00071
					1250	230/240	VSA00343	1	LMP00072
					1500	230/240	VSA00344	1	LMP00073
2500	230/240	VSA00345	2	LMP00072					

Radiant Process Heaters



VS Glow Infrared Heaters

VSC Series High Density Medium Wave

Design Features

- * Gold Coated Ceramic Reflector
- * Medium wave Infrared Radiation up to 116 watts per linear inch
- * Fast Response, Immediate ON/OFF, Time: 20-40 seconds for full heat-up
- * All Ceramic Housing Construction
- * Standard lamp voltages: 120 & 230/240
- * All units are double-ended construction

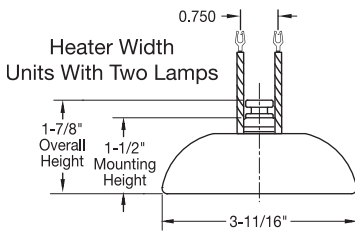
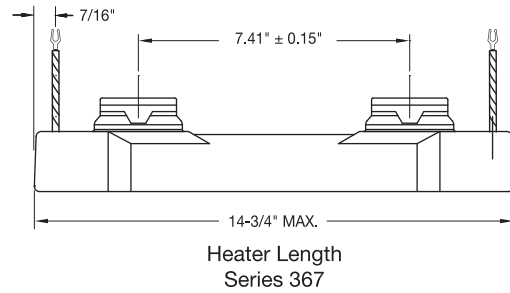
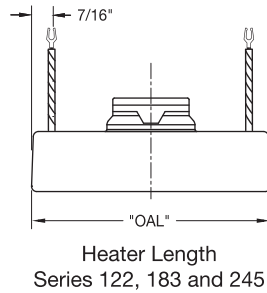
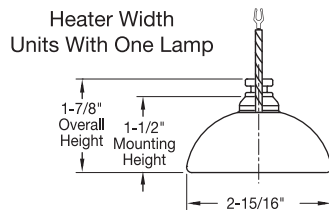

One-Piece Mounting Clips Standard
Two-Piece Wave Mounting Clips Optional
 See page 7-14 for details.

Standard (Non-Stock) VSC Series

VS Glow heaters listed have 10" mica insulated leads and a one-piece spring clip for mounting.

Series	Maximum Overall Length		Heated Length		Width		Wattage	Voltage	Part Number	Number of Lamps	Replacement Lamp Part Number
	(in)	(mm)	(in)	(mm)	(in)	(mm)					
122	4.90	124.5	1.77	45	3.67	93.1	250	120	VSC00138	2	LMP00075
					2.89	73.5	150	120	VSC00139	1	LMP00077
183	7.36	187.0	4.17	106	2.89	73.5	250	120	VSC00140	1	LMP00078
					2.89	73.5	300	120	VSC00141	1	LMP00079
					3.67	93.1	500	120	VSC00142	2	LMP00078
					2.89	73.5	250	120	VSC00143	1	LMP00080
245	9.82	249.5	6.65	168	2.89	73.5	400	120	VSC00144	1	LMP00081
					2.89	73.5	500	120	VSC00145	1	LMP00082
					3.67	93.1	800	120	VSC00146	2	LMP00081
					2.89	73.5	250	230/240	VSC00147	1	LMP00083
					2.89	73.5	400	230/240	VSC00148	1	LMP00084
					2.89	73.5	500	230/240	VSC00149	1	LMP00085
367	14.74	374.5	11.38	289	3.67	93.1	800	230/240	VSC00150	2	LMP00084
					2.89	73.5	400	120	VSC00151	1	LMP00086
					2.89	73.5	650	120	VSC00152	1	LMP00087
					2.89	73.5	800	120	VSC00153	1	LMP00088
					3.67	93.1	1300	120	VSC00154	2	LMP00087
					2.89	73.5	400	230/240	VSC00155	1	LMP00089
					2.89	73.5	650	230/240	VSC00156	1	LMP00090
					2.89	73.5	800	230/240	VSC00157	1	LMP00091
3.67	93.1	1300	230/240	VSC00158	2	LMP00090					



VSR Series Medium Wave

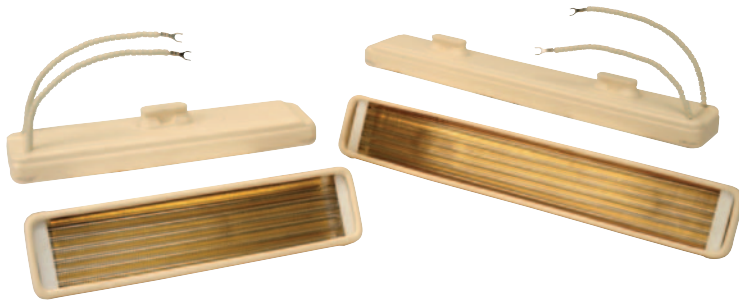

Design Features

- * All Ceramic Housing Construction
- * Capable of delivering medium and long wavelengths in any voltage from 120 to 480 volts
- * Available in clear tubes
- * 24-K gold reflective surface
- * Optional Type K thermocouple available

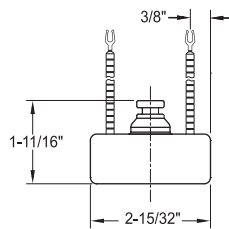

Heater Width

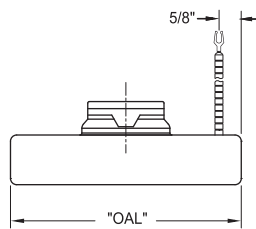

Heater Length
Series 122, 183 and 245

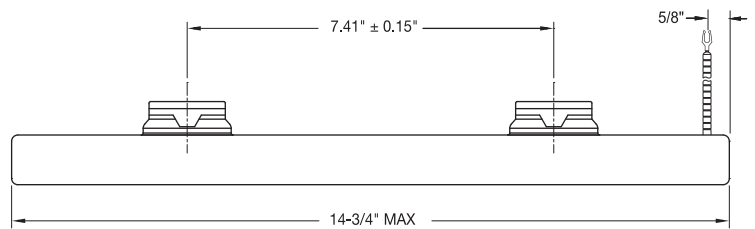

Heater Length Series 367



One-Piece Mounting Clips Standard
Two-Piece Wave Mounting Clips Optional

See page 7-14 for details.

Standard (Non-Stock) VSR Series

VS Glow heaters listed have 6" ceramic bead insulated leads with #8-10 spade terminals and a one-piece spring clip for mounting.

Series	Maximum Overall Length		Wattage	Voltage	Part Number
	(in)	(mm)			
122	4.90	124.5	125	230	VSR20001
			200	230	VSR20002
			250	230	VSR20003
			325	230	VSR20004
			500	230	VSR20005
183	7.36	187.0	185	230	VSR30001
			300	230	VSR30002
			375	230	VSR30003
			500	230	VSR30004
			750	230	VSR30005
245	9.82	249.5	250	230	VSR10001
			400	230	VSR10002
			500	230	VSR10003
			650	230	VSR10004
			1000	230	VSR10005
367	14.74	374.5	375	230	VSR40001
			600	230	VSR40002
			750	230	VSR40003
			1000	230	VSR40004
			1500	230	VSR40005



Gemini® Infrared Heater Technology Emulates the Efficiency of Solar Energy in a Convenient Package for Hundreds of Industrial and Commercial Applications

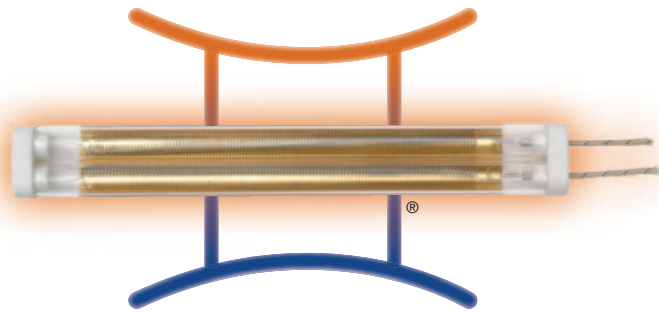

Gemini™ Medium Wave Heaters Twin Bore Quartz Tube Technology

Design Features

- * *Industry standard twin bore quartz tube formats with 95% heat transmittance*
- * *24-karat Gold Back Coating for targeted infrared applications*
- * *White Ceramic Reflective Back Coating for extreme temperature requirements*
- * *High power densities: 42/51/63.5 w/in (16/20/25 w/cm)*
- * *Fast heat-up rates — Less than one minute to reach steady state conditions*
- * *Very long operating life — Over 10,000 hours of highly efficient and economical continuous operation*
- * *Three industry standard sizes in lengths up to 118 in. (3000mm)*



Complete Infrared Heat Technology for Every Industrial and Commercial Application Under the Sun

Gemini Series – Managing the Power of the Sun in a More Convenient Package

Medium Wave Infrared E-Mitters

Tempco has developed specialized coatings to control the directional nature of the infrared energy emitted from the Gemini twin bore heaters. High levels of energy reflection are achieved by selectively bonding an integral high temperature coating to the half-hemisphere of the quartz tube surfaces facing away from the targeted sur-

face. The choice of a gold or white ceramic coating depends on the maximum operating temperature required in the heating system. Also available is a clear 360° E-Mitter for use in applications that will employ external reflective or focusing surfaces around the heater.

Gemini® Twin Tube Quartz Heaters with Gold Back Coating

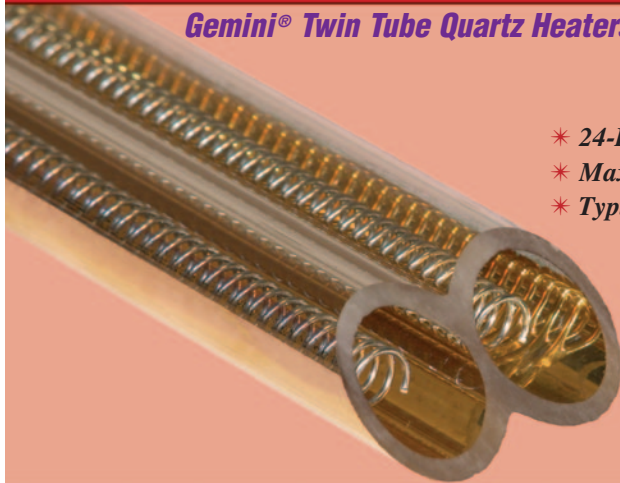

- * 24-Karat Gold Back Coating
- * Maximum Coil Temp 1472°F (800°C)
- * Typical Applications:
 - Glass Processing Industry
 - Paper and Textile Industries
 - Plastics Industry

95% Heat Reflection toward working surface

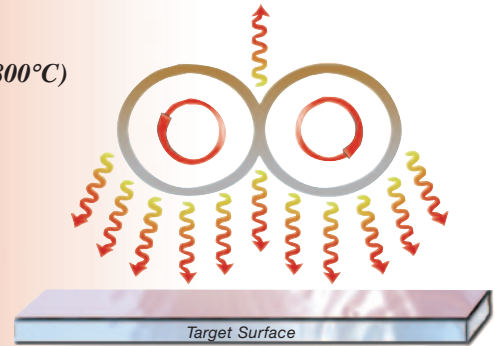

Gemini® Twin Tube Quartz Heaters with White Ceramic Back Coating

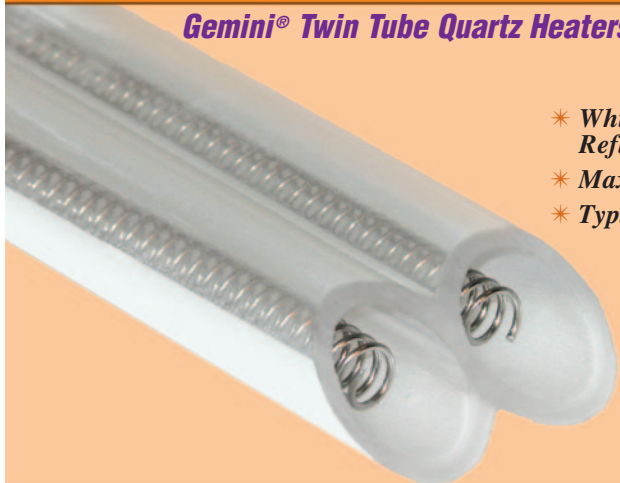

- * White Proprietary Formula Reflective Back Coating
- * Maximum Coil Temp. 2012°F (1100°C)
- * Typical Applications:
 - Stress Relieving of Metal Components
 - Drying Foils
 - Paper and Textile Industries

75% Heat Reflection toward working surface

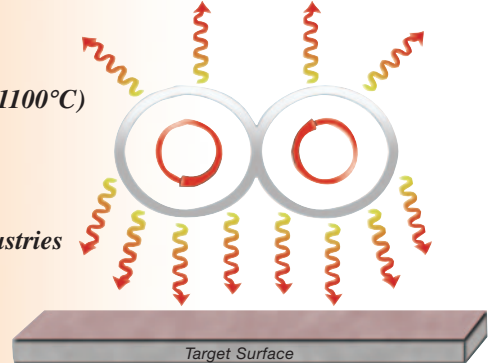

Gemini® Twin Tube Quartz Heaters Without Coating (for external reflector)

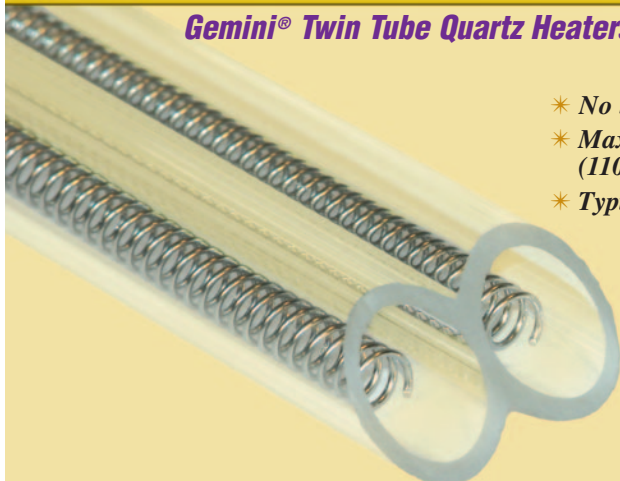

- * No back coating
- * Maximum Coil Temp. 2012°F (1100°C)
- * Typical Applications:
 - PVC Panel Coating Cure
 - Curing Coating on Rubber Seals
 - Powder Coating Industry
 - Wood Processing Industry
 - Culinary Arts Industry

360° Heat Radiation

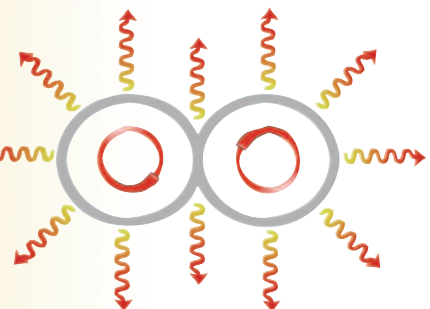

Medium Wave Infrared E-Mitters

SPECTRAL EMISSIVITY OF PET FILM

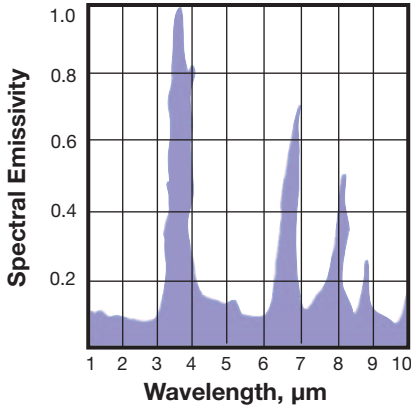

WAVELENGTH CONTROL – The very low heat transmission losses through the clear quartz material of the twin bore heaters allow Tempco’s engineers to carefully design the peak emitted wavelength of these heaters to match the peak absorption wavelength for a given material or application. By modifying the temperature of the E-mitter, its peak emitted wavelength will change according to Wien’s displacement law (see page 7-101). All E-mitters will emit a range of wavelengths above and below their peak value. (See spectrum graph on page 7-97.) The design of an efficient infrared heating system must consider both the spectral nature and directional properties of thermal radiation.

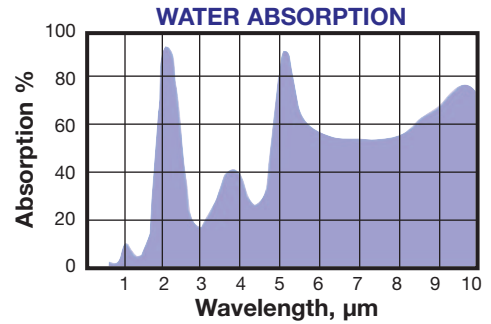

SPECTRAL NATURE: To address this issue, heaters should be designed to emit wavelengths that closely match the absorption band of the processed material in a given application. By carefully considering the broad side-bands of the emitted radiation and absorption, it is possible to design systems that will enhance the heat transfer rates at different stages of the heating process.

Infrared Energy Spectrum Emission

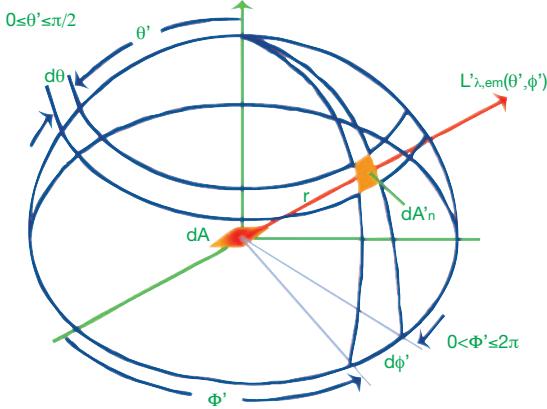

Vaporization of water is best achieved in the infrared spectrum at wavelengths in the range of 3.1 and 6.1 μm (microns). After the water is removed, the infrared heating rate should match the absorption spectrum of the base material to avoid damaging it thermally. Similar approaches are used in many industries, such as automotive, glass and plastic processing, textiles, electronics and many others.

DIRECTIONAL NATURE: The directional nature of the heat distribution is dealt with by consideration of how to direct heat toward an application. The efficiency of the heating system depends strongly on the percentage of the total infrared energy generated at the resistance coil that reaches the target material. Consideration must be given to the fact that this infrared energy propagates from the E-mitter in all possible directions with a non-uniform wavelength distribution.

Design Specifications

Performance Ratings			
Reflective Backing	Gold	White Ceramic	Clear* (no backing)
Maximum Coil Temperature	1472°F (800°C)	2012°F (1100°C)	2012°F (1100°C)
Peak Emitted Wavelength Range (microns)	2.7-6.5	2.1-6.5	2.1-6.5
Radiation Pattern	180°	180°	360°
Nominal Reflected Heat Efficiency	95%	75%	0%

*Clear tubes are designed for use with external reflector.

Electrical Ratings			
Twin Bore Tube Size	18 × 8 mm	23 × 11 mm	33 × 15 mm
Maximum Power Density (per unit length)	42 w/in (16.5 w/cm)	51 w/in (20 w/cm)	63.5 w/in (25 w/cm)
Maximum Voltage	480V	480V	600V
Maximum Amperage per circuit	9.5A	13.5A	20A

Standard wattage tolerance is +5%, -10%; closer tolerances available upon request

Medium Wave Infrared E-Mitters

Wire Leads for Standard Configuration are Stranded Lead Wire, Rated 842°F (450°C), 600V.

OAL: Overall Length
CS1: Lead End Cold Section
HL: Heated Length
CS2: Blind End Cold Section

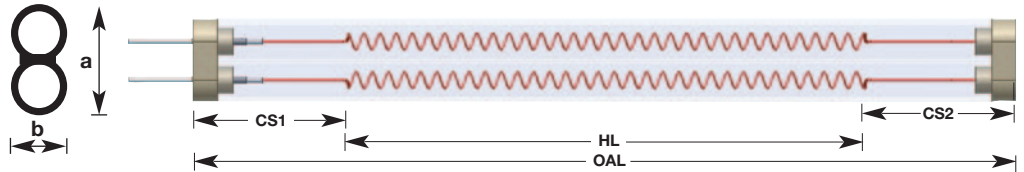

Dimensional Specifications

Twin Tube Size Dimensions (a x b)	18 x 8 mm (.71 x .31 in)	23 x 11 mm (.91 x .43 in)	33 x 15 mm (1.30 x .59 in)
Maximum Length (OAL)	2000 mm (78.75 in)	2000 mm (78.75 in)	3000 mm (118 in)
Minimum Lead End Cold Length (Standard CS1) (both ends of double end units)	50 mm (1.96 in)	50 mm (1.96 in)	50 mm (1.96 in)
Minimum Blind End Cold Length (Standard CS2) (single ended units only)	50 mm (1.96 in)	50 mm (1.96 in)	50 mm (1.96 in)
Overall Length (OAL) Tolerance	± 2.5 mm (0.10 in)		
Heated Length (HL) Tolerance	± 6.5 mm (0.26 in)		

Consult factory for closer tolerances.



Exceptional Clear Quartz Twin Bore Material with Proven Application Results

- **Automotive:** Airbag assembly, headliner formation, roof rack bonding, mirror manufacturing, flux powder drying, adhesive activation on protective strips, powder coating, spot repair, friction material bonding, plastic bumper drying, forming & painting
- **Plastics:** PET bottle blow molding, pellet/granulate drying, polypropylene fiber fusing, plastic component extruding/bending, ink drying, and laminating
- **Glass:** Preheating, coating/paint curing, light bulb production
- **Food Industry:** Chocolate processing, cake heating/baking, food warming
- **Paper, Electronics** ➤ **Metals** ➤ **Semi-conductor Processing**
➤ **Textiles,** ➤ **Furniture** ➤ **And much more**

Gemini Series

Standard Design (Non-Stock) Gemini Medium Wave Infrared E-Mitters

Leads for Standard Configuration are Stranded Lead Wire, Rated 842°F (450°C), 600V.

OAL: Overall Length

CS1: Lead End Cold Section

HL: Heated Length

CS2: Blind End Cold Section

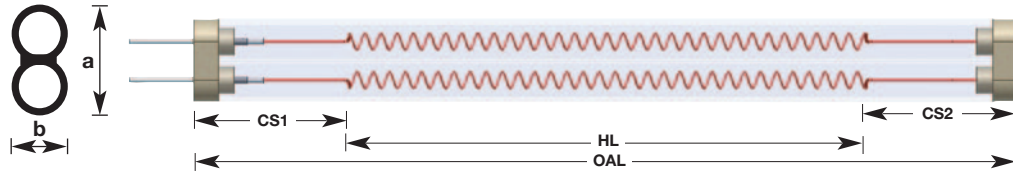

Twin Bore Quartz Format Dimensions				Overall Length		Heated Length		Power Watts	Part Numbers @ 230 Volts Coatings			Linear Power Watts per inch	Configuration Style	Lead Exit Angle
a		b							Gold	White	None			
in	mm	in	mm	in	mm	in	mm							
0.71	18	0.31	8	15.7	400	11.8	300	500	GEM00001	GEM10001	GEM20001	42.4	A	0°
0.91	23	0.43	11	23.6	600	19.7	500	1000	GEM00002	GEM10002	GEM20002	50.8	A	0°
1.30	33	0.59	15	35.4	900	31.5	800	2000	GEM00003	GEM10003	GEM20003	63.5	A	0°
1.30	33	0.59	15	43.3	1100	39.4	1000	2500	GEM00004	GEM10004	GEM20004	63.5	A	0°
0.91	23	0.43	11	51.2	1300	47.2	1200	2500	GEM00005	GEM10005	GEM20005	53.0	A	0°
1.30	33	0.59	15	55.9	1420	51.2	1300	3250	GEM00006	GEM10006	GEM20006	63.5	A	0°
1.30	33	0.59	15	63.0	1600	59.1	1500	3750	GEM00007	GEM10007	GEM20007	63.5	A	0°
1.30	33	0.59	15	66.9	1700	63.0	1600	4000	GEM00008	GEM10008	GEM20008	63.5	A	0°
1.30	33	0.59	15	70.9	1800	66.9	1700	4100	GEM00009	GEM10009	GEM20009	61.3	A	0°
1.30	33	0.59	15	75.6	1920	70.9	1800	4500	GEM00010	GEM10010	GEM20010	63.5	A	0°
1.30	33	0.59	15	83.5	2120	78.7	2000	5000	GEM00011	GEM10011	GEM20011	63.5	B	0°
1.30	33	0.59	15	102.4	2600	98.4	2500	6250	GEM00012	GEM10012	GEM20012	63.5	B	0°
0.71	18	0.31	8	15.7	400	11.8	300	500	GEM00013	GEM10013	GEM20013	42.4	A	90°
0.91	23	0.43	11	23.6	600	19.7	500	1000	GEM00014	GEM10014	GEM20014	50.8	A	90°
1.30	33	0.59	15	35.4	900	31.5	800	2000	GEM00015	GEM10015	GEM20015	63.5	A	90°
1.30	33	0.59	15	43.3	1100	39.4	1000	2500	GEM00016	GEM10016	GEM20016	63.5	A	90°
0.91	23	0.43	11	51.2	1300	47.2	1200	2500	GEM00017	GEM10017	GEM20017	53.0	A	90°
1.30	33	0.59	15	55.9	1420	51.2	1300	3250	GEM00018	GEM10018	GEM20018	63.5	A	90°
1.30	33	0.59	15	63.0	1600	59.1	1500	3750	GEM00019	GEM10019	GEM20019	63.5	A	90°
1.30	33	0.59	15	66.9	1700	63.0	1600	4000	GEM00020	GEM10020	GEM20020	63.5	A	90°
1.30	33	0.59	15	70.9	1800	66.9	1700	4100	GEM00021	GEM10021	GEM20021	61.3	A	90°
1.30	33	0.59	15	75.6	1920	70.9	1800	4500	GEM00022	GEM10022	GEM20022	63.5	A	90°
1.30	33	0.59	15	83.5	2120	78.7	2000	5000	GEM00023	GEM10023	GEM20023	63.5	B	90°
1.30	33	0.59	15	102.4	2600	98.4	2500	6250	GEM00024	GEM10024	GEM20024	63.5	B	90°

Optional Winding Patterns

Using alternate stretching configurations to achieve distributed wattage, Tempco can easily customize Gemini series heaters to fit your application. Below are various configurations with “A” Standard for Single Ended and “B” Standard for Double Ended.

Single Ended Terminations

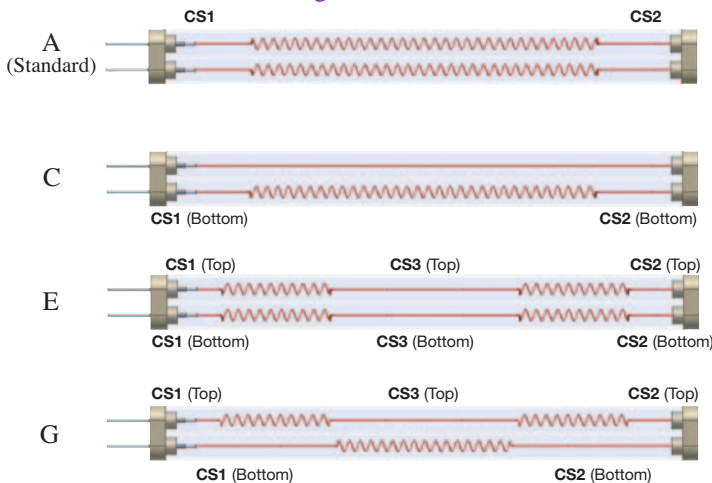

Double Ended Terminations

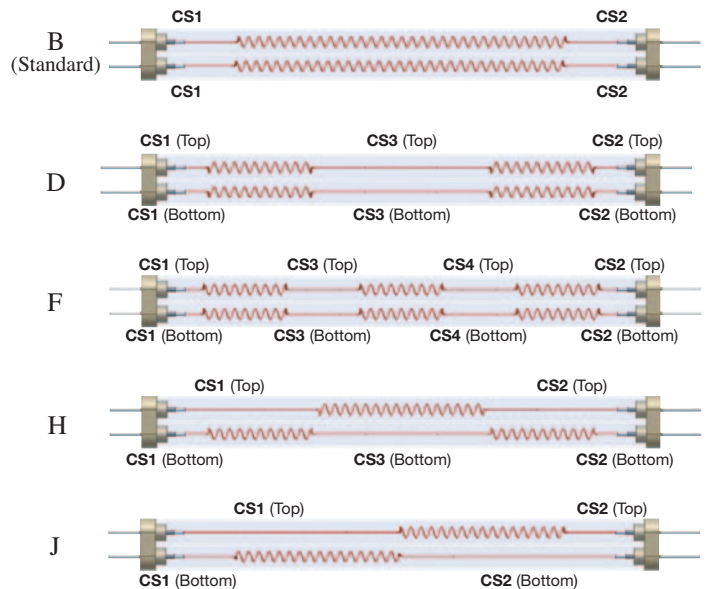

Gemini Medium Wave Infrared E-Mitters

Lead configurations and lengths – 842°F (450°C), 600V insulated lead wire, 3/8" stripped ends standard, oriented straight out ends or at 90° to heater axis. Optional styles of high temperature insulated lead wire and un-insulated ring or spade terminals are available to suit your application. Select size and style from charts

on page 7-23. Bare stranded heater leads up to 9" long may be ordered with optional ceramic bead insulators. Longer lengths are available as lead wire options only. When ordering, specify lead orientation, style, length, and terminals.

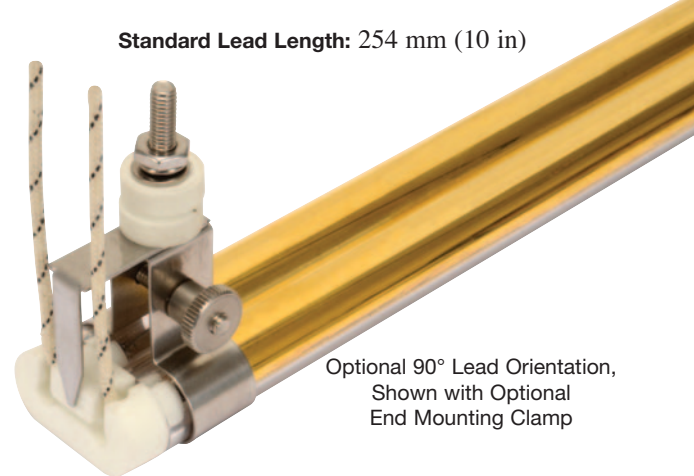
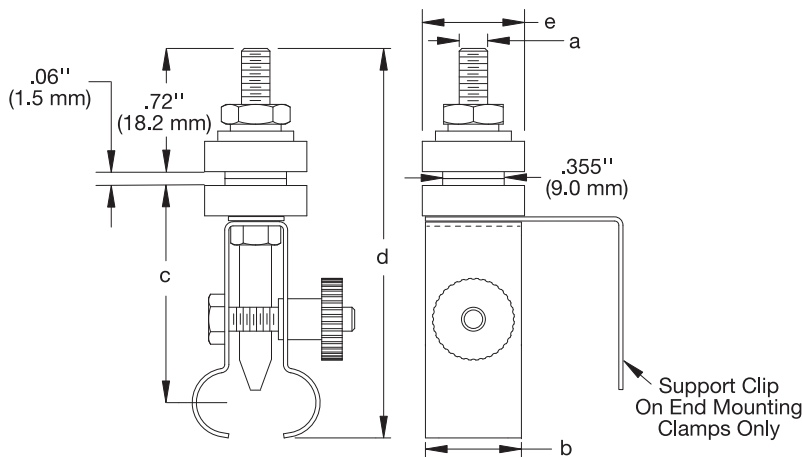

Gemini Stainless Steel Clamp Specifications and Dimensions

Clamp Assembly Part Number	CRK00085	CRK00086	CRK00087	CRK00088	CRK00089	CRK00090
Fits Twin Tube Size	18 × 8 mm		23 × 11 mm		33 × 15 mm	
Clamp Location on Tube	Center	End	Center	End	Center	End
Clamps Required	OAL > 39.4" (1000 mm)	2 per heater	OAL > 59.1" (1500 mm)	2 per heater	OAL > 78.7" (2000 mm)	2 per heater
Mounting Stud Threads (a)	10-32		10-32		10-32	
Clamp Width (b)	0.40" (10.2 mm)		0.40" (10.2 mm)		0.60" (15.2 mm)	
Heater Mounting Height (c)	1.20" (30.5 mm)		1.20" (30.5 mm)		1.41" (35.8 mm)	
Overall Clamp Height (d)	2.44" (62 mm)		2.48" (63.1 mm)		2.77" (70.3 mm)	
Ceramic Insulator Diameter (e)	0.59" (15 mm)		0.59" (15 mm)		0.59" (15 mm)	
Panel Mounting Hole Diameter	0.375" (9.5 mm)		0.375" (9.5 mm)		0.375" (9.5 mm)	

Recommended mounting panel thickness range is 18-14 ga.

Ordering Information

Stock Heaters

Order by Tempco Part Number for heaters listed on page 7-66.

Custom Engineered/Manufactured Heaters

Because TEMPCO understands that an electric heater can be very application specific, for sizes not listed TEMPCO will design and manufacture a Gemini Infrared Heater or modular housing to meet your requirements. **Standard lead time is 3 weeks.**

Please Specify the following:

- Reflective Coating — Gold, White Ceramic or None
- Twin Bore Tube Size (18 × 8 mm, 23 × 11 mm, or 33 × 15 mm)
- Wattage or Watts/In
- Single or Double End
- Overall Length (OAL)
- Heated Length (HL)
- Lead Orientation (0° or 90°)
- Voltage
- Quantity
- Lead Wire Terminals (page 7-23)
- Lead Wire Style/Length (Page 7-23)
- Winding Pattern (page 7-66, A-J or as required)
- Ceramic Bead Option (9" max. length)
- CRA Linear Housing Option (See page 7-68)
- Cold End Lengths (CE1 & CE2) See Winding Pattern page 7-66

⚠ WARNING: Cancer and Reproductive Harm - www.P65Warnings.ca.gov.

Gemini Series

Gemini Medium Wave Infrared E-Mitter Assemblies using a CRA Linear Housing

CRA Linear Modular Housing Assemblies

These compact assemblies have one 33 × 15 mm twin bore Gemini quartz heater mounted in front of an aluminized steel reflector at a power density of 63.5 w/linear inch.

Design Features

- * Rapid heat-up/cool-down and low residual heat retention
- * Compact lightweight extruded anodized housing
- * High efficiency aluminized steel reflector for harsh environments and high temperature applications
- * Adaptable to all Gemini twin bore sizes

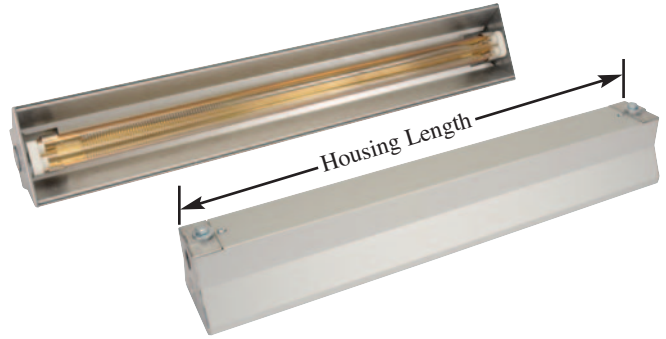

Standard (Non-Stock) and Stock Sizes and Electrical Ratings – 230V

Stock Items Are Shown In **RED**

Watts	Housing Length		Heated Length (HL)		Housing Assembly Part Number			Replacement Heater Part Number			Winding Pattern See Page 7-66
	in	mm	in	mm	Gold	White	None	Gold	White	None	
2000	36.19	919	31.5	800	CRA80001	CRA80015	CRA80024	GEM00015	GEM10015	GEM20015	A
2500	44.06	1119	39.4	1000	CRA80002	CRA80016	CRA80025	GEM00016	GEM10016	GEM20016	A
3250	56.63	1438	51.2	1300	CRA80003	CRA80017	CRA80026	GEM00018	GEM10018	GEM20018	A
3750	63.75	1619	59.1	1500	CRA80004	CRA80018	CRA80027	GEM00019	GEM10019	GEM20019	A
4000	67.69	1719	63.0	1600	CRA80005	CRA80019	CRA80028	GEM00020	GEM10020	GEM20020	A
4100	71.65	1820	66.9	1700	CRA80006	CRA80020	CRA80029	GEM00021	GEM10021	GEM20021	A
4500	76.38	1940	70.9	1800	CRA80007	CRA80021	CRA80030	GEM00022	GEM10022	GEM20022	A
5000	84.25	2140	78.7	2000	CRA80008	CRA80022	CRA80031	GEM00023	GEM10023	GEM20023	B
6250	103.13	2620	98.4	2500	CRA80009	CRA80023	CRA80032	GEM00024	GEM10024	GEM20024	B



Warning: Gemini Heaters are designed to be used in a horizontal position only.

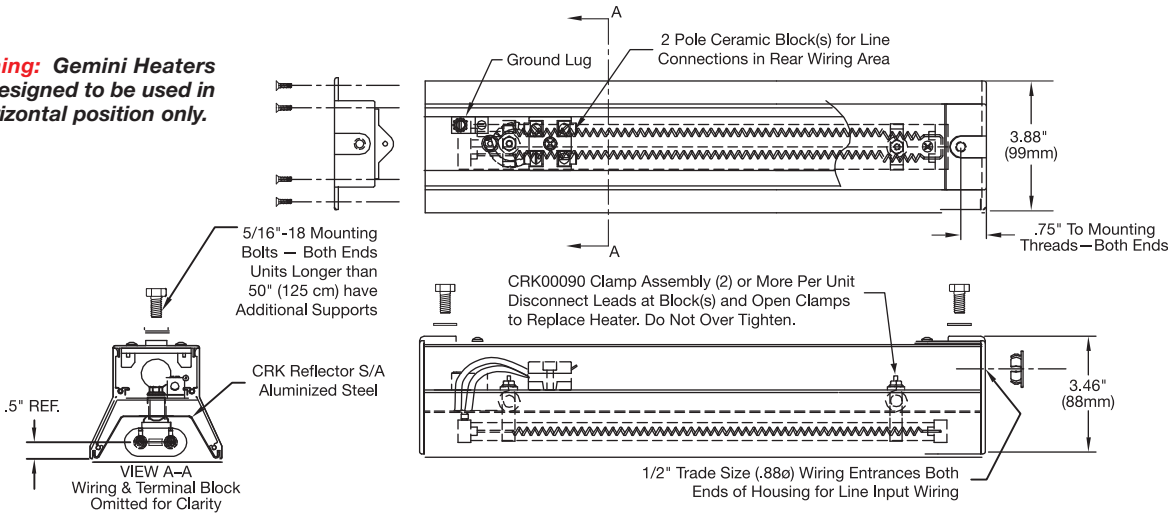

Ordering Information

Select a Part Number from the Standard Sizes and Electrical Ratings table that meets your requirement.

Custom housings are available for any twin tube size (18 × 8 mm, 23 × 11 mm, and 33 × 15 mm; see page 7-67) Gemini Series Heater. Specify watts, volts and heated length (or w/in) required and TEMPCO will design a unit to suit your application. Clear, gold, or white ceramic coated heaters and doubled end wiring, and chrome steel reflector options are available.

WARNING: Cancer and Reproductive Harm - www.P65Warnings.ca.gov.

Wiring Diagrams for Gemini E-Mitter in a CRA Linear Housing

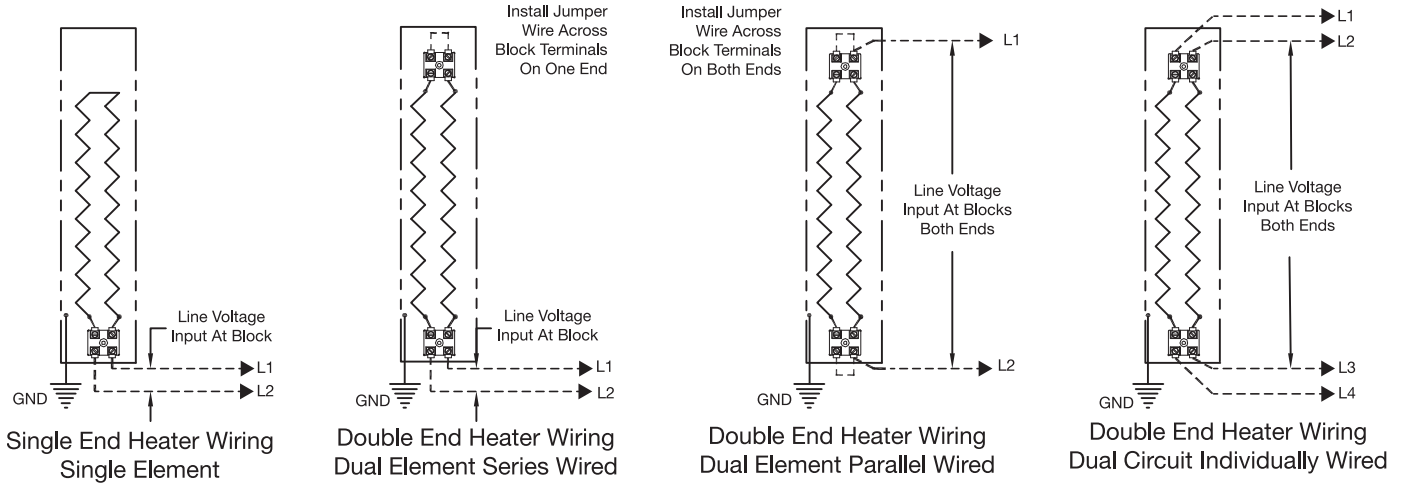

Warning: Hazard of Electrical Shock. Installation must be grounded to earth. Disconnect power before installing or servicing heater.

Minimum Spacing Between Gemini Medium Wave Heaters

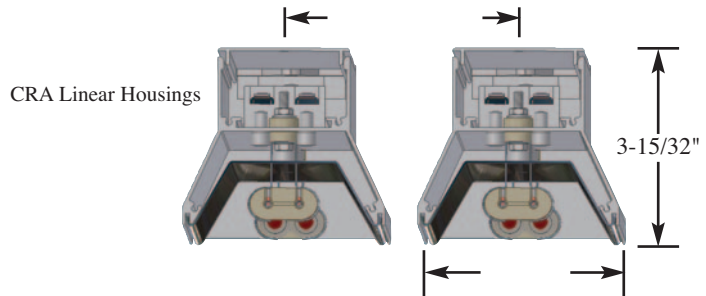
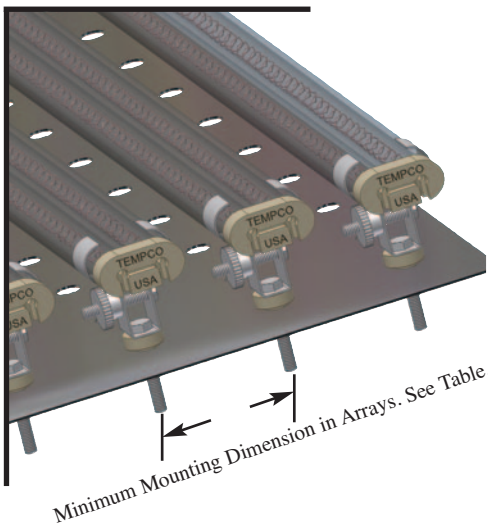

Minimum Spacing between Heaters in Array Assemblies ("D" Dim.) and CRA Linear Housings

Twin Bore Tube Size	18 x 8 mm	23 x 11 mm	33 x 15 mm
Minimum Center to Center Spacing of Heaters Mounted in ARG Arrays ("D Dim.")	1.43"	1.63"	2.00"
Minimum Center to Center Spacing of Heaters Mounted in CRA Linear Housings	4.00"	4.00"	4.00"

Type ARG Gemini Medium Wave Infrared E-Mitter Panel Arrays

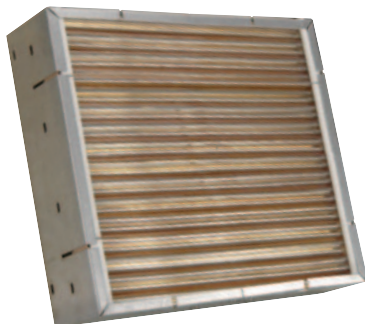

Custom panel arrays are available. Tempco will design and build to your specifications. Consult us with your requirements.



Radiant Process Heaters



KRD Radiant Quartz Heaters

Vitreous Silica Quartz Tube

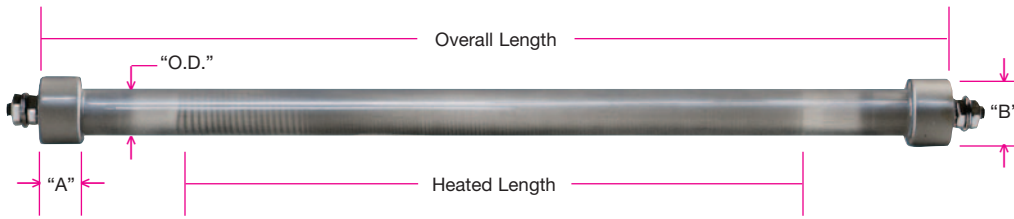

Quartz Heater Dimensions

Quartz Tube O.D.	"A"	"B"
3/8"	3/8"	5/8"
1/2"	1/2"	7/8"
5/8"	1/2"	7/8"

Tempco Radiant Quartz heaters are one of the most efficient sources of radiant energy. They are ideally suited for processes that require wavelengths in the medium 4.0-2.4 micron band for efficient operation. These heaters are capable of generating full heat output in 80-100 seconds with a cool-down range of 180-225 seconds depending on the mass of the resistance coil and power density level.

They offer excellent life when used in either rapid cycling or continuous radiant heating applications. To achieve the best operating life, these quartz heaters should be operated with surface watt densities in the 35-40 watts per square inch range, not exceeding the maximum power densities specified below.

Construction Features

The heater consists of a helically wound resistance wire coil enclosed in a pure vitreous silica fused quartz tube with a translucent (semi-opaque) surface. The tubing is terminated at the ends with specially designed ceramic caps securely fastened with high temperature ceramic cement providing support for the field wiring screw terminals used for power connections.

The diffusion effect of the opaque quartz tube surface broadens the emitted wavelength range without creating objectionable glare due to emissions in the visible spectrum. Optimum design provides a clear red color on the translucent tube surface when operating at full line voltage. The emitted wavelength band is almost completely absorbed by the process and considered best for most industrial radiant applications.

Typical Applications

- ➔ Shrink Packaging Tunnels
- ➔ Fusing Plastics
- ➔ Food Warming
- ➔ Drying Photo Film Equipment
- ➔ Drying Sand Cores
- ➔ Laminating
- ➔ Vulcanizing Rubber
- ➔ Thawing
- ➔ Curing Rubber
- ➔ Space Heaters
- ➔ Thermoforming
- ➔ Sterilization
- ➔ Electrostatic Copying Equipment
- ➔ Drying Textiles
- ➔ Thermal Copying Equipment
- ➔ Plastic Forming
- ➔ Sealing
- ➔ Food Processing
- ➔ Drying Lacquers and Paints

QUARTZ HEATER SPECIFICATIONS – DIMENSIONAL

Diameters: 3/8", 1/2" and 5/8"
Max. Length: 3/8" dia. – 50"
 1/2" dia. – 100"
 5/8" dia. – 100"
Length Tolerance: Up to 12" long $\pm 1/8$ " Minimum
 Over 12" long $\pm 2\%$

QUARTZ HEATER SPECIFICATIONS – ELECTRICAL

Max. Volts: 480 Volts
Max. Amperage: 20 Amps
Resistance Tolerance: +10%, -5%
Wattage Tolerance: +5%, -10%
Max Watt Density: 40 Watts/sq. in.

Mounting Clamp for 3/8 Quartz Tube OD

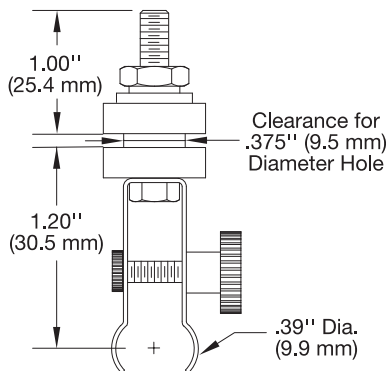

Mounting Clamp Part Number: CRK00059

Type ARK Vitreous Silica Quartz Tube Panel Arrays

Custom 4" high Type ARK panels with 1/2" diameter quartz elements are available. Tempco will design and build to your specifications. Consult us with your requirements.



Warning: Quartz Heaters are designed to be used in a Horizontal Position Only

View Product Inventory @ www.tempco.com

Vitreous Silica Quartz Tube

Standard Sizes and Electrical Ratings

Vitreous Silica Quartz Tube heaters listed have Type T1 termination.

Quartz Tube Diameter	Overall Length		Heated Length		Watts	Part Number	
	in	mm	in	mm		120V	240V
3/8"	14	355.6	12½	317.5	480	KRD00001	KRD00002
	20	508.0	18½	469.9	720	KRD00003	KRD00004
	26	660.4	24½	622.3	960	KRD00005	KRD00006
	38	965.2	36½	927.1	1450	KRD00007	KRD00008
	48	1219.2	46½	1181.1	1900	—	KRD00009
1/2"	18	457.2	16½	419.1	900	KRD00010	KRD00011
	20	508.0	18½	469.9	900	KRD00012	KRD00013
	26	660.4	24½	622.3	1200	KRD00014	KRD00015
	36	914.4	34½	876.3	1800	KRD00016	KRD00017
	38	965.2	36½	927.1	1800	KRD00018	KRD00019
	42	1066.8	40½	1028.7	1580	KRD00020	KRD00021
	48	1219.2	46½	1181.1	1820	KRD00022	KRD00023
	50	1270.0	48½	1231.9	2400	—	KRD00024
	54	1371.6	52½	1333.5	2060	—	KRD00025
	60	1524.0	58½	1485.9	2300	—	KRD00026
	66	1676.4	64½	1638.3	2540	—	KRD00027
72	1828.8	70½	1790.7	2780	—	KRD00028	
5/8"	24	609.6	21	533.4	1075	KRD00029	KRD00030
	26	660.4	23	584.2	1800	KRD00031	KRD00032
	30	762.0	27	685.8	1375	KRD00033	KRD00034
	38	965.2	35	889.0	2500	—	KRD00035
	42	1066.8	39	990.6	1975	KRD00036	KRD00037
	48	1219.2	45	1143.0	2275	—	KRD00038
	50	1270.0	47	1193.8	3400	—	KRD00039
	54	1371.6	51	1295.4	2575	—	KRD00040
	60	1524.0	57	1447.8	2875	—	KRD00041
	62	1574.8	59	1498.6	4200	—	KRD00042
	66	1676.4	63	1600.2	3175	—	KRD00043
72	1828.8	69	1752.6	3475	—	KRD00044	

Terminations



Type T1 Standard Termination
10-32 thread screw terminal standard termination.

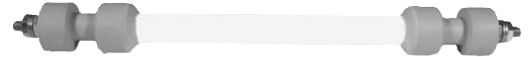

Type T2 Panel Mount Bushings
10-32 thread screw terminals with extension bushings for CRA/TRH housing assemblies.



Type ST Tabs with Slotted Holes
1/2" wide x 3/4" long, with a 9/32" x 3/8" slot. Alternate mounting method.



Type FT Quick Disconnect Fuse Type
Fuse-type connector provides ease of installation. Connectors are 3/8" OD x 1/2" long brass.



Type L1 Straight-Out Leads
10" flexible lead wire externally spliced standard. If longer leads are required, specify.



Type C4 Ceramic Caps with Leads
This termination provides 10-32 screw terminals insulated with ceramic terminal covers. Screws are prewired with 10" flexible lead wire. If longer leads are required, specify (also for T1 or T2).

Ordering Information

Catalog Heaters

Order by Part number for standard heaters listed above.

Part Numbers listed are for heaters supplied with Type 1 Termination. For other terminations a Part Number will be issued at time of order.

Custom Engineered/Manufactured Heaters

Understanding that an electric heater can be very application specific, for sizes and ratings not listed, **TEMPCO** will design and manufacture a Radiant Quartz Heater to meet your requirements.

Standard lead time is 3 weeks.

Please Specify the following:

- Diameter
- Overall Length
- Heated Length
- Wattage
- Voltage
- Termination Type
- Lead Length; if applicable
- Mounting Clamps (See page 7-70)

⚠ WARNING: Cancer and Reproductive Harm - www.P65Warnings.ca.gov.

(800) 323-6859 • Email: sales@tempco.com

KRH Quartz Radiant Heaters

Quartz Sheath Medium Wave Radiant Heater Assemblies in a Universal 2000 Housing



Designed for use in applications that require rapid on/off response and fast heat-up and cooldown rates. These heater assemblies are designed to operate in the medium wavelength range of 4.0-2.4 microns (700 to 1715°F peak emitter temperatures). These Modular Housing assemblies utilize a .50 diameter translucent “milky white” vitreous quartz tube enclosing a high temperature resistance wire coil. The diffusion effect of the translucent quartz tube surface broadens the emitted infrared wavelength range obtained without objectionable glare due to low emissions in the visible spectrum. The units have either single or dual heaters mounted at the focal point of a polished aluminum reflector within the housing. These heater assemblies are available in a wide range of power densities. For housing dimensions and mounting details see page 7-76.

Design Features

- * *Direct Retrofit into existing NEMA 1 applications*
- * *Rugged Universal 2000 anodized aluminum housing*
- * *Wattage range of 600W to 7200W in standard designs*
- * *Voltages of 120-480V available depending on heated length*
- * *Power densities up to 65w/in per heater (20 amps max/heater)*
- * *Maximum Housing assembly length 84"; minimum 15"*
- * *Fast response, 40-80 sec for full element heat-up*
- * *Full cooldown in less than 4-8 minutes*
- * *Single end wiring option available*
- * *Multiple heat/dual voltage wiring options for dual heater units*
- * *Utilizes standard TRH removable guard designs*
- * *External power wiring options available*

Standard (Non-Stock) KRH1 Sizes & Ratings (55-60 w/in.) – Single Element Double End Termination

Wattage	Volts	Overall Length		Heated Length		Part Number without Guard	Part Number with Guard	Replacement Element Part Number	Replacement Protective Wire Guard	Replacement Reflector Set Part Number
		in	mm	in	mm					
600	120	18	457	9.75	248	KRH10001	KRH10030	KRD00266	GRD-104-104	SMPR-1018
	208					KRH10002	KRH10031	KRD00267		
	240					KRH10003	KRH10032	KRD00252		
	277					KRH10004	KRH10033	KRD00268		
900	120	24	610	15.75	401	KRH10005	KRH10034	KRD00269	GRD-104-105	SMPR-1019
	208					KRH10006	KRH10035	KRD00270		
	240					KRH10007	KRH10036	KRD00271		
	277					KRH10008	KRH10037	KRD00272		
1300	120	30	762	21.75	553	KRH10009	KRH10038	KRD00273	GRD-104-106	SMPR-1020
	208					KRH10010	KRH10039	KRD00274		
	240					KRH10011	KRH10040	KRD00275		
	277					KRH10012	KRH10041	KRD00276		
1600	208	36	914	27.75	705	KRH10013	KRH10042	KRD00277	GRD-104-107	SMPR-1021
	240					KRH10014	KRH10043	KRD00278		
	277					KRH10015	KRH10044	KRD00279		
	480					KRH10016	KRH10045	KRD00280		
2400	208	48	1219	39.75	1010	KRH10017	KRH10046	KRD00281	GRD-104-108	SMPR-1022
	240					KRH10018	KRH10047	KRD00282		
	277					KRH10019	KRH10048	KRD00283		
	480					KRH10020	KRH10049	KRD00284		
3000	208	60	1524	51.75	1315	KRH10021	KRH10050	KRD00285	GRD-104-109	SMPR-1023
	240					KRH10022	KRH10051	KRD00286		
	277					KRH10023	KRH10052	KRD00287		
	480					KRH10024	KRH10053	KRD00288		
3600	208	72	1829	63.75	1619	KRH10025	KRH10054	KRD00289	GRD-104-110	SMPR-1024
	240					KRH10026	KRH10055	KRD00290		
	277					KRH10027	KRH10056	KRD00291		
	480					KRH10028	KRH10057	KRD00292		
						KRH10029	KRH10058	KRD00293		

NOTES: See page 7-76 for housing dimensions and mounting details.
Shipped with Instruction Sheet IDP-129-104 for installation, wiring and maintenance information.



KRH Quartz Radiant Heater Assemblies

Quartz Sheath Medium Wave Radiant Heater Assemblies in a Universal 2000 Housing

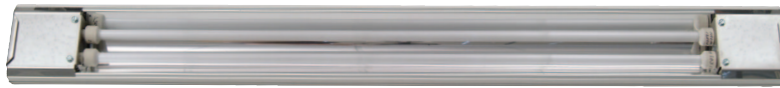

Standard (Non-Stock) KRH2 Sizes & Ratings (110-120 w/in.) – Double Element Double End Termination

Wattage	Volts	Overall Length		Heated Length		Part Number without Guard	Part Number with Guard	Replacement Element Part Number	Replacement Protective Wire Guard	Replacement Reflector Set Part Number
		in	mm	in	mm					
1200	120	18	457	9.75	248	KRH20001	KRH20030	KRD00266	GRD-104-104	SMPR-1018
	208					KRH20002	KRH20031	KRD00267		
	240					KRH20003	KRH20032	KRD00252		
	277					KRH20004	KRH20033	KRD00268		
						KRH20005	KRH20034	KRD00269		
1800	120	24	610	15.75	401	KRH20006	KRH20035	KRD00270	GRD-104-105	SMPR-1019
	208					KRH20007	KRH20036	KRD00271		
	240					KRH20008	KRH20037	KRD00272		
	277									
2600	120	30	762	21.75	553	KRH20009	KRH20038	KRD00273	GRD-104-106	SMPR-1020
	208					KRH20010	KRH20039	KRD00274		
	240					KRH20011	KRH20040	KRD00275		
	277					KRH20012	KRH20041	KRD00276		
	480					KRH20013	KRH20042	KRD00277		
3200	208	36	914	27.75	705	KRH20014	KRH20043	KRD00278	GRD-104-107	SMPR-1021
	240					KRH20015	KRH20044	KRD00279		
	277					KRH20016	KRH20045	KRD00280		
	480					KRH20017	KRH20046	KRD00281		
4800	208	48	1219	39.75	1010	KRH20018	KRH20047	KRD00282	GRD-104-108	SMPR-1022
	240					KRH20019	KRH20048	KRD00283		
	277					KRH20020	KRH20049	KRD00284		
	480					KRH20021	KRH20050	KRD00285		
6000	208	60	1524	51.75	1315	KRH20022	KRH20051	KRD00286	GRD-104-109	SMPR-1023
	240					KRH20023	KRH20052	KRD00287		
	277					KRH20024	KRH20053	KRD00288		
	480					KRH20025	KRH20054	KRD00289		
7200	208	72	1829	63.75	1619	KRH20026	KRH20055	KRD00290	GRD-104-110	SMPR-1024
	240					KRH20027	KRH20056	KRD00291		
	277					KRH20028	KRH20057	KRD00292		
	480					KRH20029	KRH20058	KRD00293		

NOTES: See page 7-77 for housing dimensions and mounting details.

The Quartz elements are supplied at the same rated voltage as the overall assembly to be wired in parallel.

120V or 240V rated assemblies can be used at twice the rated voltage by wiring the elements in series. (120/240V or 240/480V)

Shipped with Instruction Sheet IDP-129-104 for installation, wiring and maintenance information.

Installation Notes:

Series KRH units are for Horizontal mounting only. KRD elements have T2, 10-32 terminals at both ends for field wiring connections. See page 7-71 for details. Wiring used in the junction boxes must be rated 250°C or higher, sized per NEC/NFPA for unit voltage and current carrying capacity. Use only 450°C rated wiring in internal wireways for single end or multiple heat options. When using copper wire for field wiring, use only nickel plated or nickel clad conductors.

Unplated or silver plated copper must not be used. See page 7-82 & 7-83 for wiring options. Do not mount heater housing closer than 6" to any combustible or structural material that does not have at least a 200°C continuous temperature rating.

Danger: Hazard of fire. These heaters are not for use in atmospheres where flammable or combustible vapors, dust, gases, or liquids are present as defined in the National Electrical Code. Where solvents, water vapor or other VOCs are being evaporated from the process, it is necessary to provide substantial quantities of ventilating air to remove all resulting vapors.

Wiring Options

Series KRH Heaters can be prewired with plain leads, stainless steel armor cable, galvanized armor cable, stainless steel wire braid or SJO cable. For additional information See Wiring Options on page 7-17.

TUBULAR RADIANT HEATER ASSEMBLIES



UNIVERSAL 2000®

Universal 2000 heaters are ideal for reliable service, providing great flexibility for many diverse industrial and commercial applications.

Designed for Maximum Efficiency, Ease of Installation and Trouble-Free Service...

As the product name implies, Universal 2000 radiant heaters are a direct retrofit replacement for existing and new applications, utilizing similar products regardless of make.

Their unique design offer several quality enhancements without compromising fit and function on existing applications.

Delivering Value-Added Performance

Universal 2000 heaters are ideal for reliable service, providing great flexibility for many diverse industrial and commercial applications. Manufactured with the proper options, Universal 2000 Radiant Heater Assemblies can be used outdoors or in wet locations.

Typical Applications

- ➔ *Adhesive Drying*
- ➔ *Comfort Heating*
- ➔ *Conveyorized Drying*
- ➔ *Drying Bulk Materials*
- ➔ *Drying Ceramics*
- ➔ *Food Warming*
- ➔ *Freeze Protection*
- ➔ *Heating Rubber or Steel Rolls*
- ➔ *Ink Drying*
- ➔ *Manufacturing Glass & Mirrors*
- ➔ *Moisture Evaporation*
- ➔ *Outdoor Comfort Heating*
- ➔ *Paint Drying*
- ➔ *Resin Curing*
- ➔ *Shrink Fitting*
- ➔ *Thermoforming*
- ➔ *Washdown Facilities*
- ➔ *Welding Preheating*

Universal 2000

Construction Characteristics

The Universal 2000 Radiant Heater stands apart from all other similar products. Its rugged construction, enhanced design features and flexibility in installation allow it to be used in applications requiring a single unit or to be used as modules creating various configurations for process radiant heating systems.

Universal 2000 Radiant Heaters are available in a full range of standard construction variations, physical dimensions and electrical ratings. They are also available in custom engineered/manufactured units up to 132" (3353 mm) for series TRH1, 4 and 6. TRH3 and 5 series units are available up to 120" (3048 mm) lengths. Special electrical ratings, single end wiring, dual voltage, multiple heat designs, and optional fast response Quartz heater options (TRH1 & 2 NEMA1 units only), along with pre-wired units using flexible/rigid conduit or SJO cord/plug can be custom designed to fit your application.

Design Features

- * Direct retrofit to existing applications
- * Rugged anodized extruded aluminum housing
- * Polished aluminum reflector (replaceable)
- * Incoloy® sheath tubular heaters (replaceable)
- * Element Support brackets (replaceable)
- * Sliding mounting bolts (replaceable)
- * Dual internal wireways for single end wiring
- * Ground terminal lug
- * Slots for heat shield on side of housing for between units
- * Convenient field wiring
- * Made to order

Typical Installations

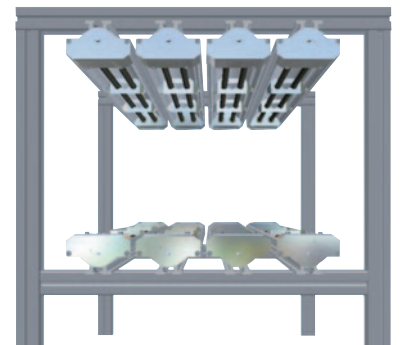
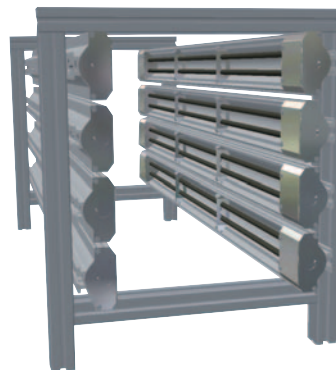
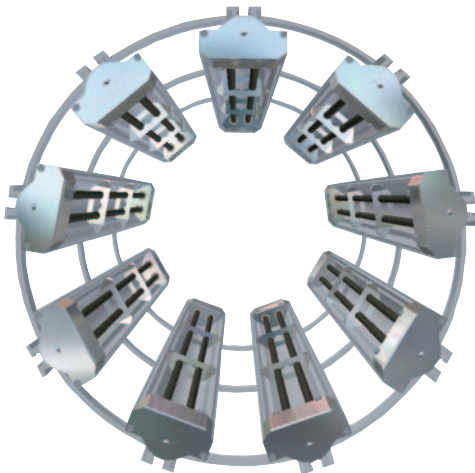
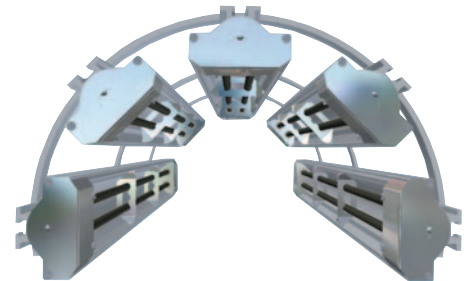
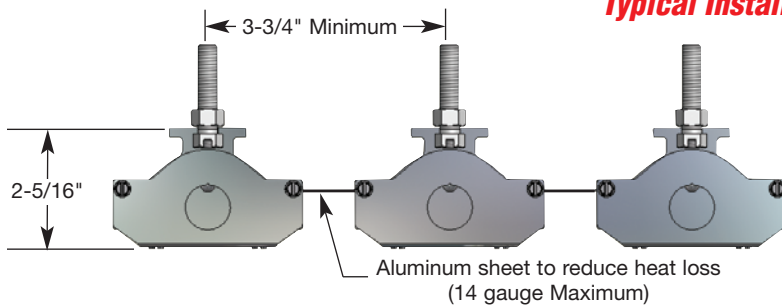

Ordering Information

Catalog Heaters

Part Numbers in red are in stock for immediate delivery. Non-Stock Part Numbers are standard designs.

Custom Engineered/Manufactured Heaters

Understanding that an electric heater can be very application specific, for sizes and ratings not listed, Tempco can manufacture a Tubular Radiant Heater to meet your requirements. **Standard lead time is 4 weeks.**

Please Specify the following:

- Overall Housing Length
- Wattage and Voltage
- Termination Features
- Wiring Options (Single or Double Ended)
- Series Construction Style

⚠ WARNING: Cancer and Reproductive Harm - www.P65Warnings.ca.gov.

(800) 323-6859 • Email: sales@tempco.com

TRH1 Series — Single Straight Element Double End Termination

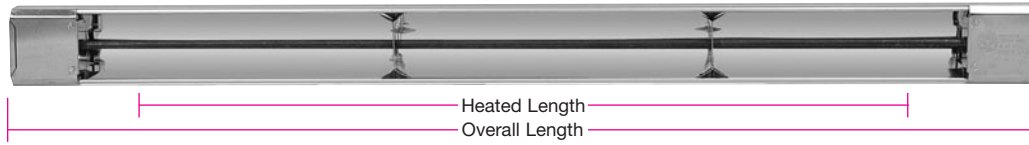

Standard (Non-Stock) Sizes and Electrical Ratings

Wattage	Volts	Overall Length in.	Heated Length in.	Part Number without Wire Guard	Part Number with Protective Wire Guard	Replacement Heating Element	Replacement Protective Wire Guard	Replacement Reflector Set
600	120	18	10	TRH10001	TRH10040	THE09100	GRD-104-104	SMPR-1018
	208			TRH10002	TRH10046	THE09101		
	240			TRH10003	TRH10047	THE09102		
	277			TRH10004	TRH10048	THE09103		
800	120	24	16	TRH10005	TRH10049	THE09104	GRD-104-105	SMPR-1019
	208			TRH10006	TRH10050	THE09105		
	240			TRH10007	TRH10051	THE09106		
	277			TRH10008	TRH10052	THE09107		
1100	120	30	22	TRH10009	TRH10053	THE09108	GRD-104-106	SMPR-1020
	208			TRH10010	TRH10054	THE09109		
	240			TRH10011	TRH10055	THE09110		
	277			TRH10012	TRH10056	THE09111		
1300	208	36	28	TRH10014	TRH10058	THE09113	GRD-104-107	SMPR-1021
	240			TRH10015	TRH10059	THE09114		
	277			TRH10016	TRH10060	THE09115		
	480			TRH10017	TRH10061	THE09116		
1800	208	48	40	TRH10018	TRH10062	THE09117	GRD-104-108	SMPR-1022
	240			TRH10019	TRH10063	THE09118		
	277			TRH10020	TRH10064	THE09119		
	480			TRH10021	TRH10065	THE09120		
2500	208	60	51	TRH10022	TRH10066	THE09121	GRD-104-109	SMPR-1023
	240			TRH10023	TRH10067	THE09122		
	277			TRH10024	TRH10068	THE09123		
	480			TRH10025	TRH10069	THE09124		
3000	208	72	63	TRH10026	TRH10070	THE09125	GRD-104-110	SMPR-1024
	240			TRH10027	TRH10071	THE09126		
	277			TRH10028	TRH10072	THE09127		
	480			TRH10029	TRH10073	THE09128		
3600	208	84	75	TRH10030	TRH10044	THE09129	GRD-104-111	SMPR-1025
	240			TRH10031	TRH10074	THE09130		
	277			TRH10032	TRH10075	THE09131		
	480			TRH10033	TRH10076	THE09132		



Optional Heating Element Protective Guard

Prevents accidental direct contact with heating element.

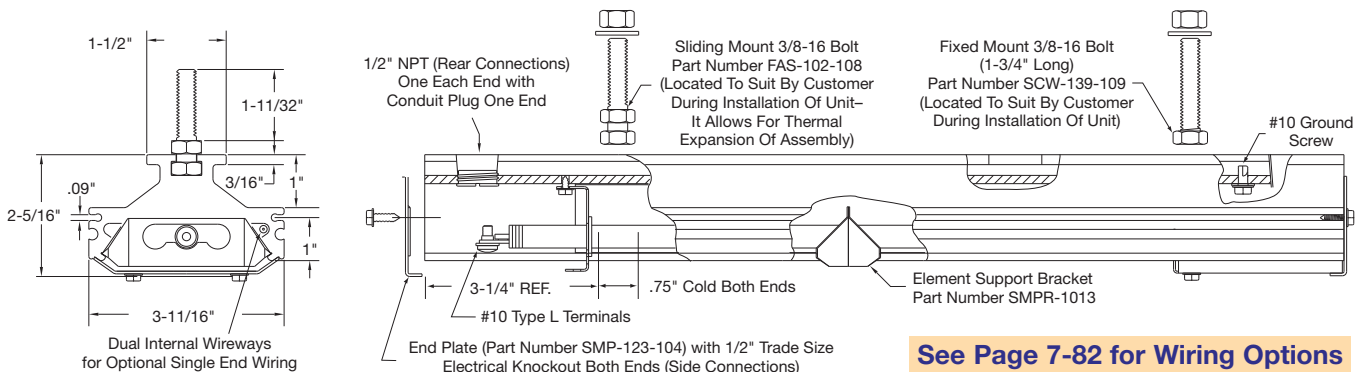

See Page 7-82 for Wiring Options

See Page 7-84 for Stock Heavy Duty Quick Disconnect Plugs and Receptacles



TRH2 Series — Dual Straight Element Double End Termination

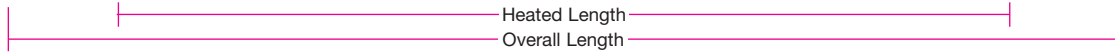

Standard (Non-Stock) Sizes and Electrical Ratings

Wattage	Volts	Overall Length in.	Heated Length in.	Part Number without Wire Guard	Part Number with Protective Wire Guard	Replacement Heating Element	Replacement Protective Wire Guard	Replacement Reflector Set
1200	120	18	10	TRH20001	TRH20054	THE09100	GRD-104-104	SMPR-1018
	208			TRH20002	TRH20055	THE09101		
	240			TRH20003	TRH20056	THE09102		
	277			TRH20004	TRH20057	THE09103		
1600	120	24	16	TRH20005	TRH20058	THE09104	GRD-104-105	SMPR-1019
	208			TRH20006	TRH20059	THE09105		
	240			TRH20007	TRH20060	THE09106		
	277			TRH20008	TRH20061	THE09107		
2200	120	30	22	TRH20009	TRH20062	THE09108	GRD-104-106	SMPR-1020
	208			TRH20010	TRH20063	THE09109		
	240			TRH20011	TRH20064	THE09110		
	277			TRH20012	TRH20065	THE09111		
2600	208	36	28	TRH20014	TRH20067	THE09113	GRD-104-107	SMPR-1021
	240			TRH20015	TRH20068	THE09114		
	277			TRH20016	TRH20069	THE09115		
	480			TRH20017	TRH20070	THE09116		
3600	208	48	40	TRH20018	TRH20071	THE09117	GRD-104-108	SMPR-1022
	240			TRH20019	TRH20072	THE09118		
	277			TRH20020	TRH20073	THE09119		
	480			TRH20021	TRH20074	THE09120		
5000	208	60	51	TRH20022	TRH20075	THE09121	GRD-104-109	SMPR-1023
	240			TRH20023	TRH20050	THE09122		
	277			TRH20024	TRH20076	THE09123		
	480			TRH20025	TRH20077	THE09124		
6000	208	72	63	TRH20026	TRH20078	THE09125	GRD-104-110	SMPR-1024
	240			TRH20027	TRH20079	THE09126		
	277			TRH20028	TRH20080	THE09127		
	480			TRH20029	TRH20081	THE09128		
7200	208	84	75	TRH20030	TRH20082	THE09129	GRD-104-111	SMPR-1025
	240			TRH20031	TRH20083	THE09130		
	277			TRH20032	TRH20084	THE09131		
	480			TRH20033	TRH20085	THE09132		



Note: Tubular elements are supplied at the same rated voltage as the overall assembly and are wired in parallel. 120 or 240V rated assemblies can be used at twice the rated voltage by wiring the elements in series (120/240V or 240/480V).

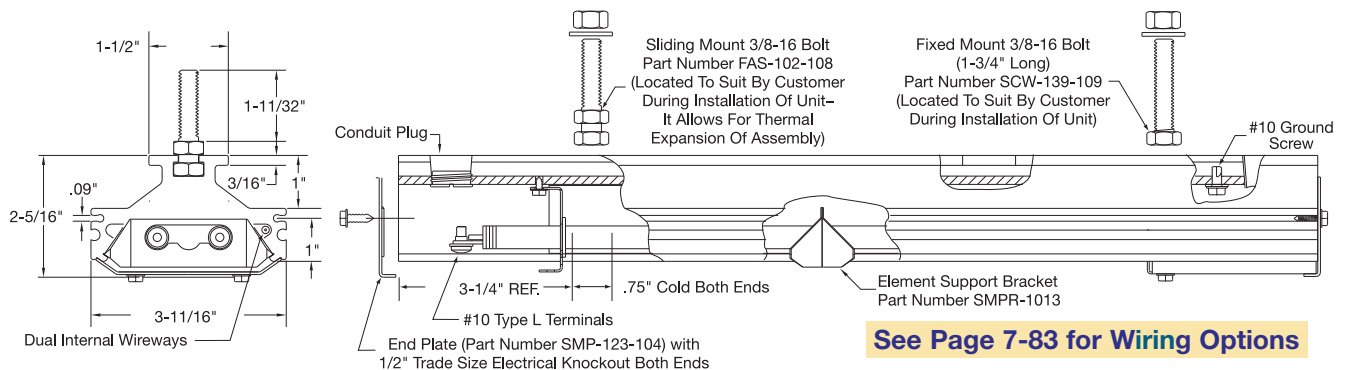

See Page 7-83 for Wiring Options

See Page 7-84 for Stock Heavy Duty Quick Disconnect Plugs and Receptacles

TRH3 Series — Single Hairpin Element Bend Single End Termination

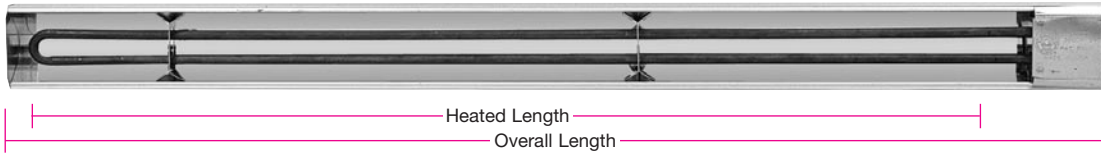

Standard (Non-Stock) and Stock Sizes and Electrical Ratings

Stock Items Are Shown In **RED**

Wattage	Volts	Overall Length in.	Heated Length in.	Part Number without Wire Guard	Part Number with Protective Wire Guard	Replacement Heating Element	Replacement Protective Wire Guard	Replacement Reflector
800	120	12	7	TRH30001	TRH30036	THE09133	GRD-104-112	SMPR-1028
	208			TRH30002	TRH30037	THE09134		
	240			TRH30003	TRH30038	THE09135		
	277			TRH30004	TRH30039	THE09136		
				TRH30005	TRH30040	THE09137		
1200	120	18	13	TRH30006	TRH30041	THE09138	GRD-104-113	SMPR-1029
	208			TRH30007	TRH30042	THE09139		
	240			TRH30008	TRH30043	THE09140		
	277			TRH30009	TRH30044	THE09141		
				TRH30010	TRH30045	THE09142		
1800	208	24	19	TRH30011	TRH30046	THE09143	GRD-104-114	SMPR-1030
	240			TRH30012	TRH30047	THE09144		
	277			TRH30013	TRH30048	THE09145		
	480			TRH30014	TRH30049	THE09146		
				TRH30015	TRH30050	THE09147		
2500	208	30	25	TRH30016	TRH30051	THE09148	GRD-104-115	SMPR-1031
	240			TRH30017	TRH30052	THE09149		
	277			TRH30018	TRH30053	THE09150		
	480			TRH30019	TRH30054	THE09151		
				TRH30020	TRH30035	THE09152		
3000	208	36	31	TRH30021	TRH30055	THE09153	GRD-104-116	SMPR-1032
	240			TRH30022	TRH30056	THE09154		
	277			TRH30023	TRH30057	THE09155		
	480			TRH30024	TRH30058	THE09156		
				TRH30025	TRH30059	THE09157		
5000	208	60	55	TRH30026	TRH30060	THE09158	GRD-104-118	SMPR-1034
	240			TRH30027	TRH30061	THE09159		
	277			TRH30028	TRH30062	THE09160		
	480			TRH30030	TRH30064	THE10305		
				TRH30031	TRH30065	THE10306		
6000	208	72	67	TRH30032	TRH30066	THE10307	GRD-104-124	SMPR-1095
	240			TRH30033	TRH30067	THE10308		
	277							
	480							

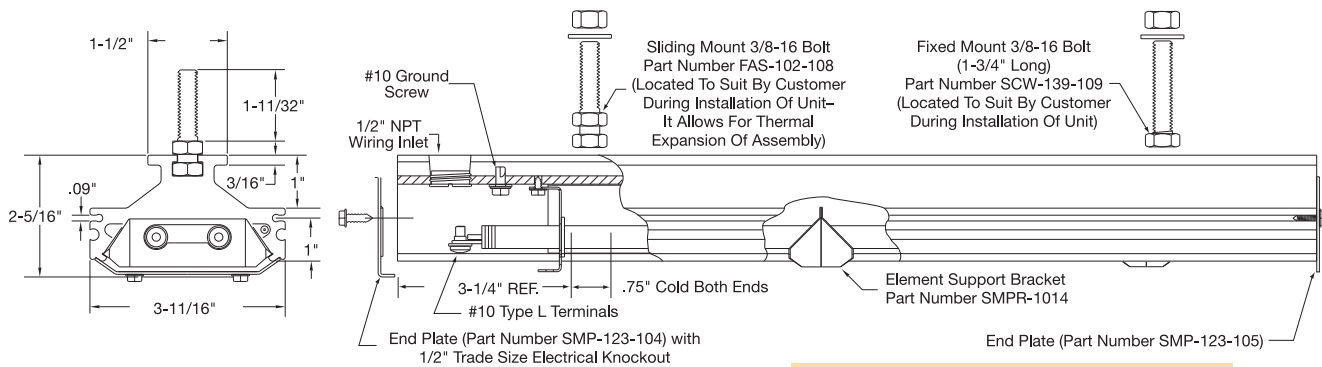

See Page 7-84 for Wiring Options

See Page 7-84 for Stock Heavy Duty Quick Disconnect Plugs and Receptacles



TRH4 Series — Dual Hairpin Element Bend Double End Termination



Standard (Non-Stock) Sizes and Electrical Ratings

Wattage	Volts	Overall Length in.	Heated Length in.	Part Number without Wire Guard	Part Number with Protective Wire Guard	Replacement Heating Element	Replacement Protective Wire Guard	Replacement Reflector Set
6000	208	72	64	TRH40001	TRH40019	THE09161	GRD-104-119	SMPR-1070
	240			TRH40002	TRH40020	THE09162		
	277			TRH40003	TRH40021	THE09163		
	480			TRH40004	TRH40022	THE09164		
7200	208	84	76	TRH40005	TRH40023	THE09165	GRD-104-120	SMPR-1069
	240			TRH40006	TRH40024	THE09166		
	277			TRH40007	TRH40025	THE09167		
	480			TRH40008	TRH40026	THE09168		
8000	208	96	88	TRH40009	TRH40027	THE09169	GRD-104-121	SMPR-1071
	240			TRH40010	TRH40028	THE09170		
	277			TRH40011	TRH40029	THE09171		
	480			TRH40012	TRH40030	THE09172		
9000	208	108	100	TRH40013	TRH40031	THE09173	GRD-104-122	SMPR-1072
	240			TRH40014	TRH40032	THE09174		
	277			TRH40015	TRH40033	THE09175		
	480			TRH40016	TRH40034	THE09176		

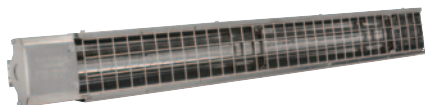

Heater with Protective Guard
Helps prevent accidental direct contact with heating element.



Note: Tubular elements are supplied at the same rated voltage as the overall assembly and are wired in parallel. 120 or 240V rated assemblies can be used at twice the rated voltage by wiring the elements in series (120/240V or 240/480V).

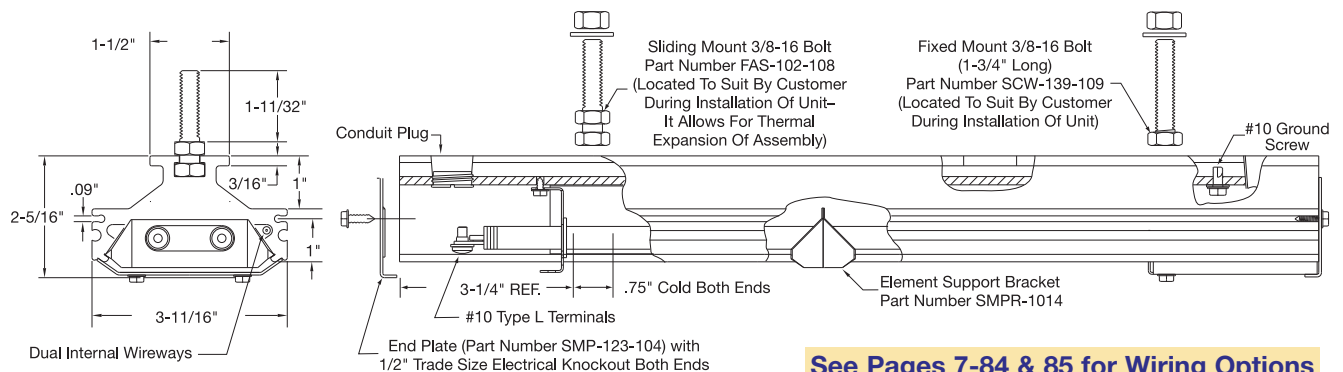

See Pages 7-84 & 85 for Wiring Options

See Page 7-84 for Stock Heavy Duty Quick Disconnect Plugs and Receptacles

TRH5 Series — Single Hairpin Element Liquid Tight Single End Termination

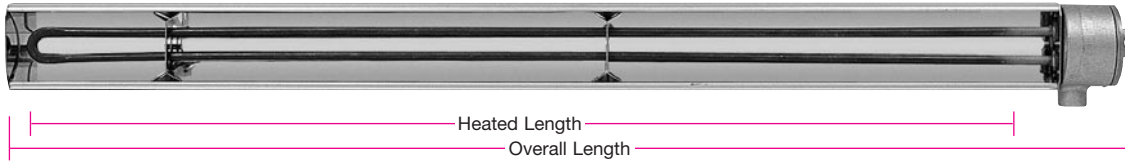

Standard (Non-Stock) and Stock Sizes and Electrical Ratings

Stock Items Are Shown In **RED**

Wattage	Volts	Overall Length in.	Heated Length in.	Part Number without Wire Guard	Part Number with Protective Wire Guard	Replacement Heating Element	Replacement Protective Wire Guard	Replacement Reflector Set
800	120	12	7	TRH50001	TRH50040	THE09177	GRD-104-112	SMPR-1035
	208			TRH50002	TRH50041	THE09178		
	240			TRH50003	TRH50042	THE09179		
	277			TRH50004	TRH50043	THE09180		
				TRH50005	TRH50044	THE09181		
1200	120	18	13	TRH50006	TRH50045	THE09182	GRD-104-113	SMPR-1036
	208			TRH50007	TRH50046	THE09183		
	240			TRH50008	TRH50047	THE09184		
	277			TRH50009	TRH50048	THE09185		
1800	208	24	19	TRH50010	TRH50049	THE09186	GRD-104-114	SMPR-1037
	240			TRH50011	TRH50050	THE09187		
	277			TRH50012	TRH50051	THE09188		
	480			TRH50013	TRH50052	THE09189		
2500	208	30	25	TRH50014	TRH50053	THE09190	GRD-104-115	SMPR-1038
	240			TRH50015	TRH50054	THE09191		
	277			TRH50016	TRH50055	THE09192		
	480			TRH50017	TRH50056	THE09193		
3000	208	36	31	TRH50018	TRH50057	THE09194	GRD-104-116	SMPR-1039
	240			TRH50019	TRH50058	THE09195		
	277			TRH50020	TRH50038	THE09196		
	480			TRH50021	TRH50059	THE09197		
3600	208	48	43	TRH50022	TRH50060	THE09198	GRD-104-117	SMPR-1040
	240			TRH50023	TRH50061	THE09199		
	240			TRH50024	TRH50062	THE09200		
	480			TRH50025	TRH50063	THE09201		
5000	208	60	55	TRH50026	TRH50064	THE09202	GRD-104-118	SMPR-1041
	240			TRH50027	TRH50065	THE09203		
	277			TRH50028	TRH50066	THE09204		
	480			TRH50033	TRH50073	THE10301		
6000	208	72	67	TRH50034	TRH50074	THE10302	GRD-104-124	SMPR-1094
	240			TRH50035	TRH50075	THE10303		
	277			TRH50036	TRH50076	THE10304		
	480							

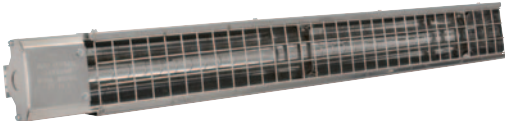

Heater with Protective Guard
Helps prevent accidental direct contact with heating element.

See Page 7-84 for Wiring Options

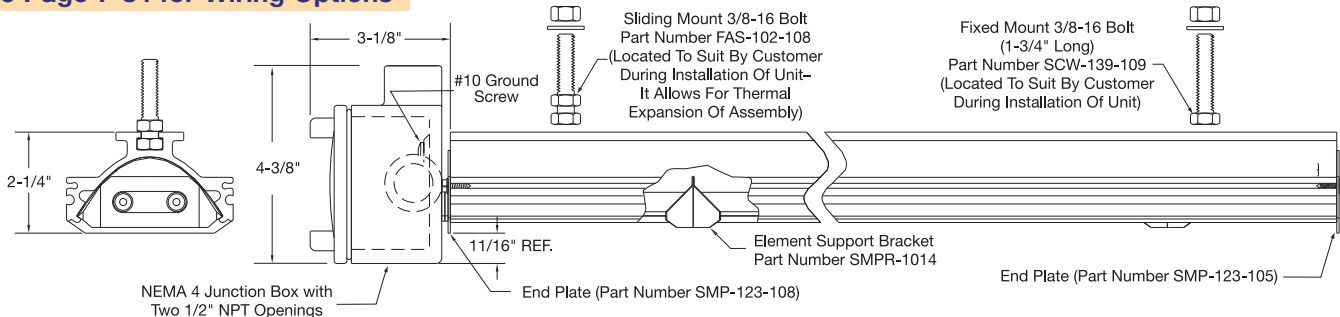

See Page 7-84 for Stock Heavy Duty Quick Disconnect Plugs and Receptacles

TRH6 Series — Dual Hairpin Element Liquid Tight Double End Termination

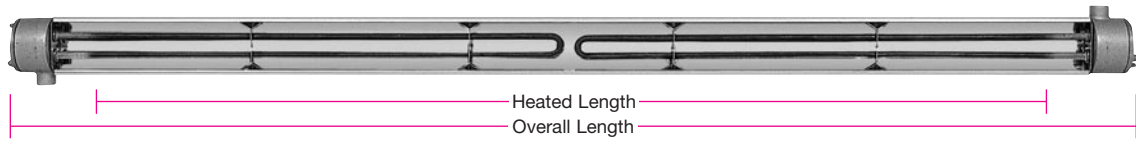

Standard (Non-Stock) Sizes and Electrical Ratings

Wattage	Volts	Overall Length in.	Heated Length in.	Part Number without Wire Guard	Part Number with Protective Wire Guard	Replacement Heating Element	Replacement Protective Wire Guard	Replacement Reflector Set
6000	208	72	64	TRH60001	TRH60020	THE09205	GRD-104-119	SMPR-1047
	240			TRH60002	TRH60021	THE09206		
	277			TRH60003	TRH60022	THE09207		
	480			TRH60004	TRH60023	THE09208		
7200	208	84	76	TRH60005	TRH60024	THE09209	GRD-104-120	SMPR-1048
	240			TRH60006	TRH60025	THE09210		
	277			TRH60007	TRH60026	THE09211		
	480			TRH60008	TRH60027	THE09212		
8000	208	96	88	TRH60009	TRH60028	THE09213	GRD-104-121	SMPR-1049
	240			TRH60010	TRH60029	THE09214		
	277			TRH60011	TRH60030	THE09215		
	480			TRH60012	TRH60031	THE09216		
9000	208	108	100	TRH60013	TRH60032	THE09217	GRD-104-122	SMPR-1050
	240			TRH60014	TRH60033	THE09218		
	277			TRH60015	TRH60034	THE09219		
	480			TRH60016	TRH60035	THE09220		



Note: Tubular elements are supplied at the same rated voltage as the overall assembly and are wired in parallel. 120 or 240V rated assemblies can be used at twice the rated voltage by wiring the elements in series (120/240V or 240/480V).

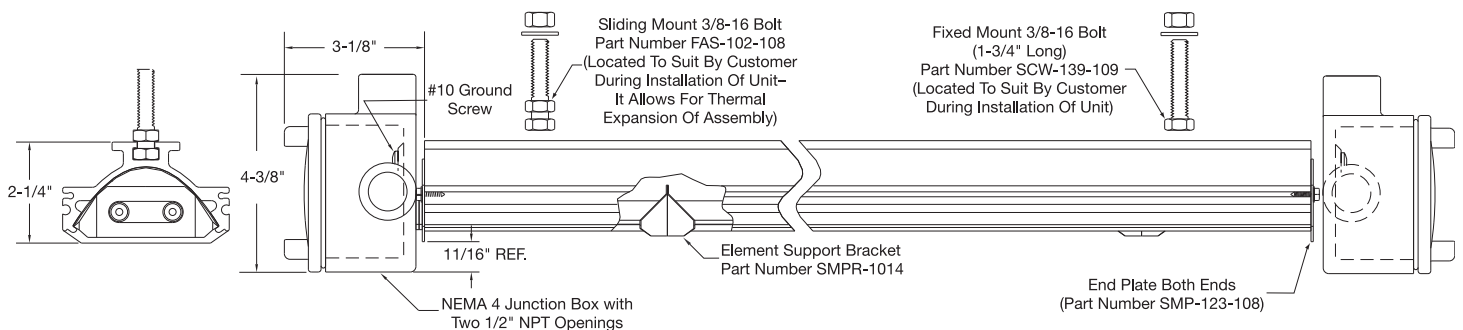

See Page 7-84 for Wiring Options

See Page 7-84 for Stock Heavy Duty Quick Disconnect Plugs and Receptacles

Installation Recommendations

Installation Recommendations

- Sliding mounting bolts (1-3/4" long, 3/8-16 thread) slide along the length of the aluminum housing for mounting the heater to common structural framing materials, creating multiple heater installations accommodating flat, rectangular, polygonal, cylindrical or any other shape arrays.
Minimum distance of 3-3/4" on center for heaters mounted side-by-side. Do not exceed 42" between sliding mounting bolts.
- To reduce heat losses, heat deflector shields up to 14 gauge thick are recommended between heaters. Fiber insulation can also be placed behind the heater housing.
- In applications where water or solvents are being evaporated, proper ventilation is required to expel vapors or fumes.
- Standard NEMA 1 electrical enclosures located at opposite ends of the heater housing with standard 7/8" diameter knock-outs and a 1/2" NPT conduit threaded opening out the top of the housing facilitate single or double end wiring. Heaters with NEMA 3-4 boxes have dual 1/2" trade size hubs oriented 90° to each other. Openings accept standard electrical fittings.
- Hold the tubular heater terminal tabs with pliers when tightening the screws to ensure secure electrical connections. Use only high temperature hook-up lead wire and nickel-plated steel or monel lugs — Available from Tempco; see page 7-23 and Section 15.



Notes: Electrical wiring should be done by a qualified electrician with full knowledge of the installation and in accordance with local codes and the National Electrical Code.

High temperature hook-up wire and terminal lugs are available from stock. See page 7-23 and Section 15.

Maintenance

- Never perform any type of service prior to disconnecting all electrical power to the heater installation.**
- To maintain reflector efficiency, clean periodically with mild soap and water. Do not use alkali or other strong cleaners. They will dull the aluminum reflector finish.
- Replacement of elements, support brackets and reflectors.**
(A) Remove terminal enclosure covers. (B) Disconnect power wires from element terminals. (C) Snap out support brackets. (D) Remove elements and old reflectors from front of unit. When replacing elements, reflectors should be replaced. Install new reflectors by snapping edges into housing grooves and reassemble other parts in reverse order.

Replacement parts are available from stock; see pages 7-86 and 7-87.



Wiring Hints – Wire selection depends on the requirements of the installation.

Wire Temperature Rating for inside the heater housing should be 482°F (250°C) or higher depending on the installation.

Voltage Rating should be equal to the operating voltage of the installation.

Wire Conductors should be nickel, nickel plated copper or nickel clad copper.

Do not use silver plated or unplated copper wire conductors.

Amperage Rating (wire gauge) should be 12 gauge for units drawing over 20 Amps of current. Use 14 gauge for units drawing under 20 Amps of current.

TRH1 (page 7-76) Standard Double-End Wiring

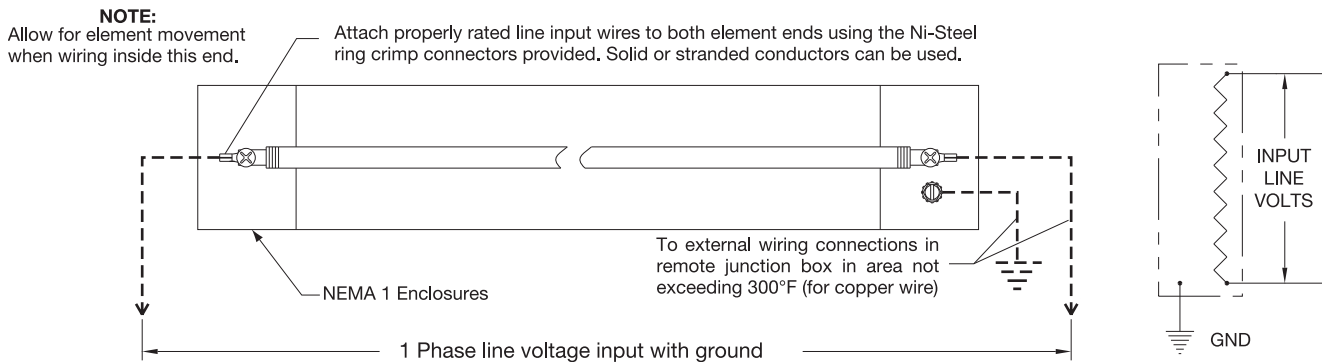

TRH1 (page 7-76) Optional Single End-Wiring

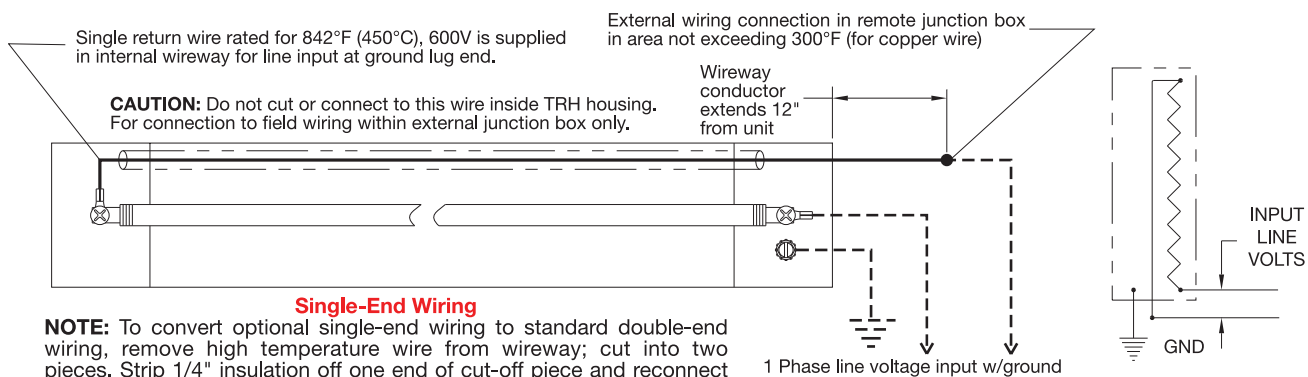

NOTE: To convert optional single-end wiring to standard double-end wiring, remove high temperature wire from wireway; cut into two pieces. Strip 1/4" insulation off one end of cut-off piece and reconnect end with ring terminal to one element end; crimp 2nd wire into ring at opposite element end.

TRH2 (page 7-77) Standard Double-End Wiring

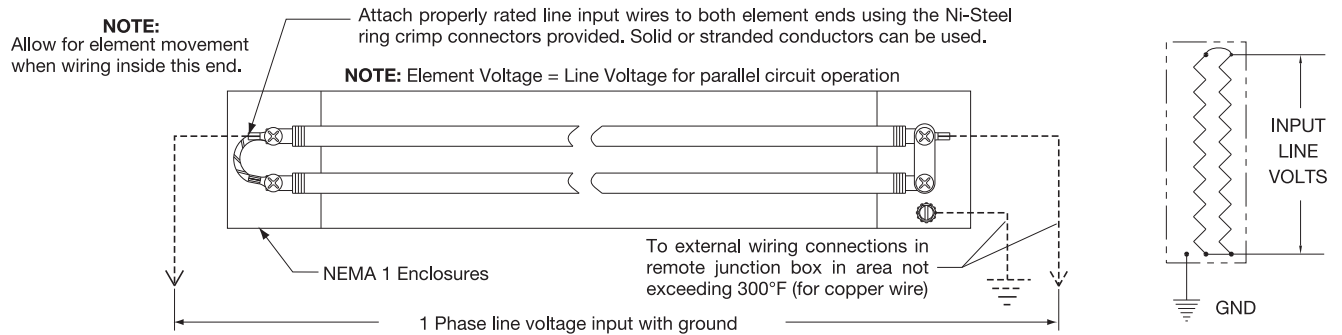

TRH2 (page 7-77) Optional Single-End Wiring

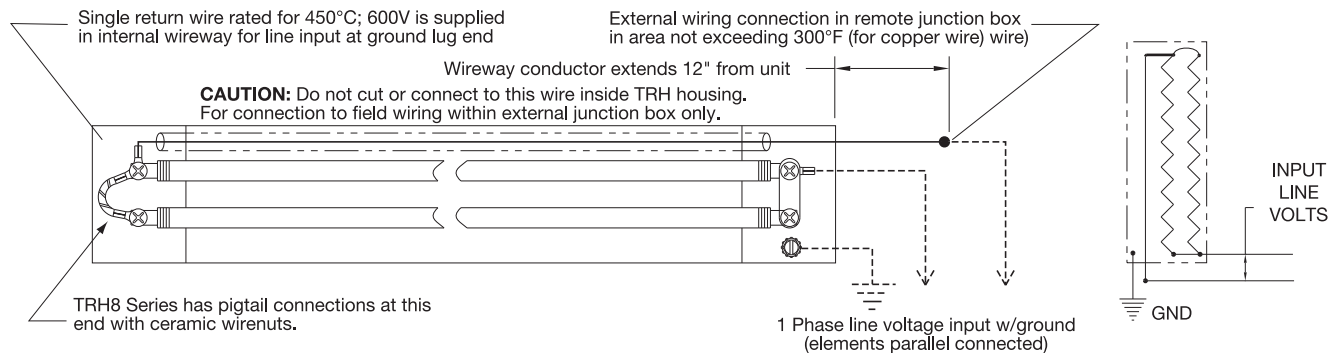

TRH2 (page 7-77) Multiple Heat/Dual Voltage Wiring

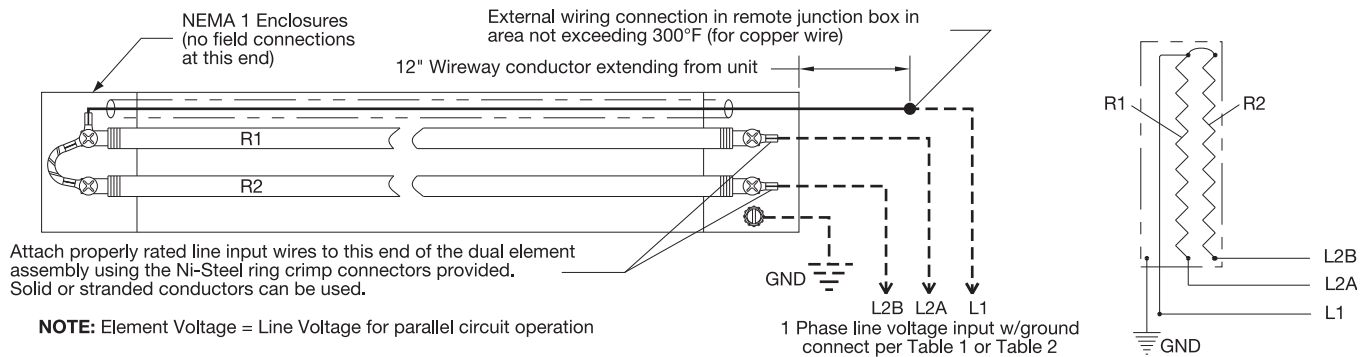

TABLE 1

Multiple Heat Connections (Single Input Voltage)

Heat Range	Line Input Wiring
Max Heat	L1 to L2A & L2B in parallel
Medium Heat	L1 to L2A or L2B only
Low Heat	L2A to L2B (L1 not used)

TABLE 2

Dual Voltage Connections (for 240/480V or 120/240V rated units)

Input Voltage	Line Input Wiring
High (480 or 240V)	L2A to L2B (L1 not used)
Low (240 or 120V)	L1 to L2A & L2B in Parallel



DANGER: Fire Hazard. Radiant Process Heaters with NEMA 1 electrical housings are not to be used in applications where flammable vapors, gases or liquids are present as defined in the National Electrical Code. Do not mount the heater closer than 6 inches to any structural or surrounding material that does not have a minimum temperature rating of continuous operation at 395°F (200°C).

Proper ventilation is required to expel vapors or fumes away from the process and personnel.

TRH3 (page 7-78) and TRH5 (page 7-80) Standard Single-End Wiring

Attach properly rated line input wires to all terminals of the element using the Ni-Steel ring crimp connectors provided. Solid or stranded conductors can be used.

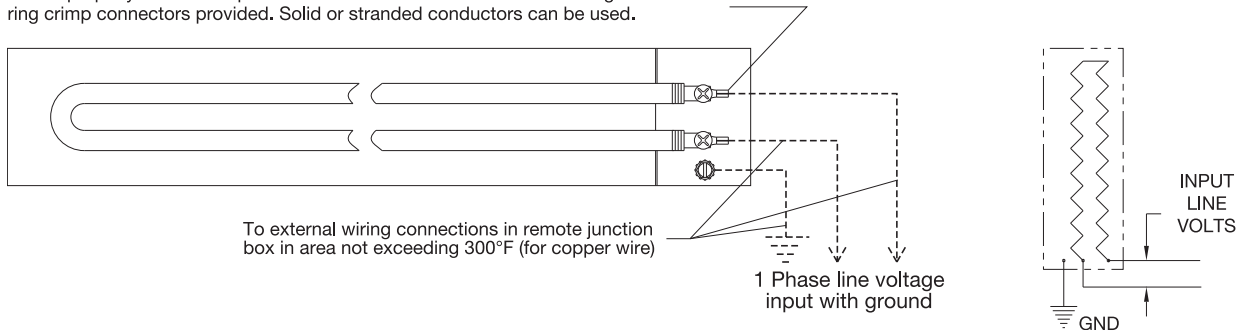

TRH4 (page 7-79) and TRH6 (page 7-81) Standard Double-End Wiring

NOTE: This is the only option available for TRH 6 series.

Attach properly rated line input wires to all terminals of the element using the Ni-Steel ring crimp connectors provided. Solid or stranded conductors can be used.

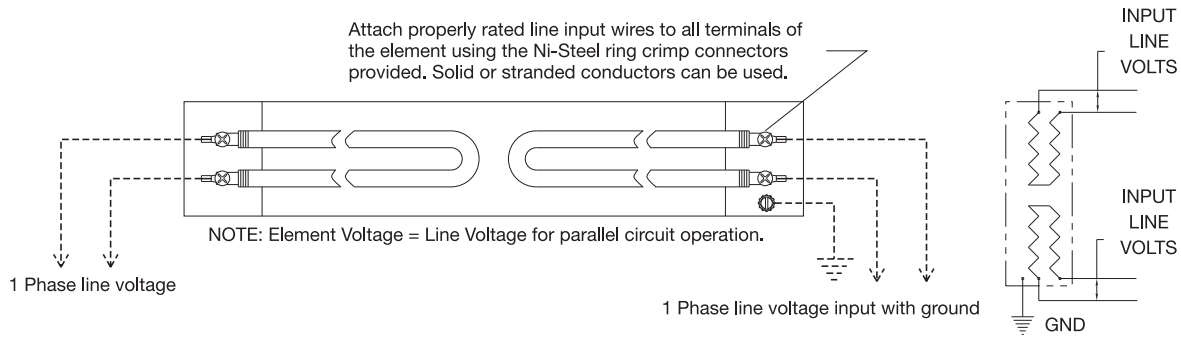

Wiring Options

Prewired with Plain Leads, Armor Cable or Wire Braid (includes ground wire)

Stainless steel armor cable — 18" armor cable over 24" leads

Galvanized armor cable — 18" armor cable over 24" leads

Stainless steel wire braid — 18" wire braid over 24" leads

Fiberglass leads (450°C rating) — 12" long plain leads

If longer leads and/or longer armor cable are required, specify when ordering.

Prewired with 24" SJO Cable (includes ground wire)

- 16 ga. cable (Up to 15 Amps)
- 14 ga. cable (Up to 22 Amps Max.)
- 12 ga. cable (Up to 28 Amps Max.)
- Max. terminal box temperature 194°F (90°C)
- If longer cable is required, specify when ordering.

Stock Heavy Duty Quick Disconnect Plugs and Connectors

Reference	NEMA P or R	Max. Amps	Volts	Plug Part Number	Connectors (Female) Part Number
P3 straight	5-15	15A	125V	EHD-102-103	EHD-103-102
P4 twist lock	L5-15	15A	125V	EHD-102-113	EHD-103-104
P6 twist lock	L6-20	20A	250V	EHD-102-122	EHD-103-105
P7 twist lock	L6-30	30A	250V	EHD-102-126	EHD-103-125



Notes: Optional Electrical Plugs listed can be attached to armor cable or SJO cord described under wiring options above.

Connectors listed are cable mount matching units for the plugs listed and are ordered separately.

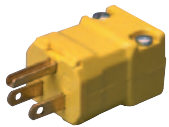

P3

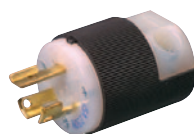

P6



P7

All Items Available from Stock

TRH4 (page 7-79) Optional Single-End Wiring

CAUTION: Do not cut or connect to these wires inside the TRH housings. For connection to field wiring within external junction box only.

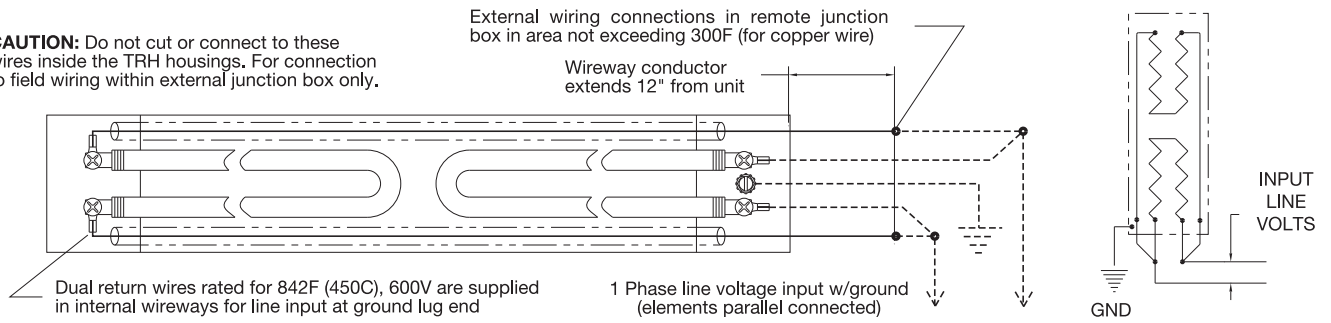

TRH4 (page 7-79) Multiple Heat/Dual Voltage Wiring

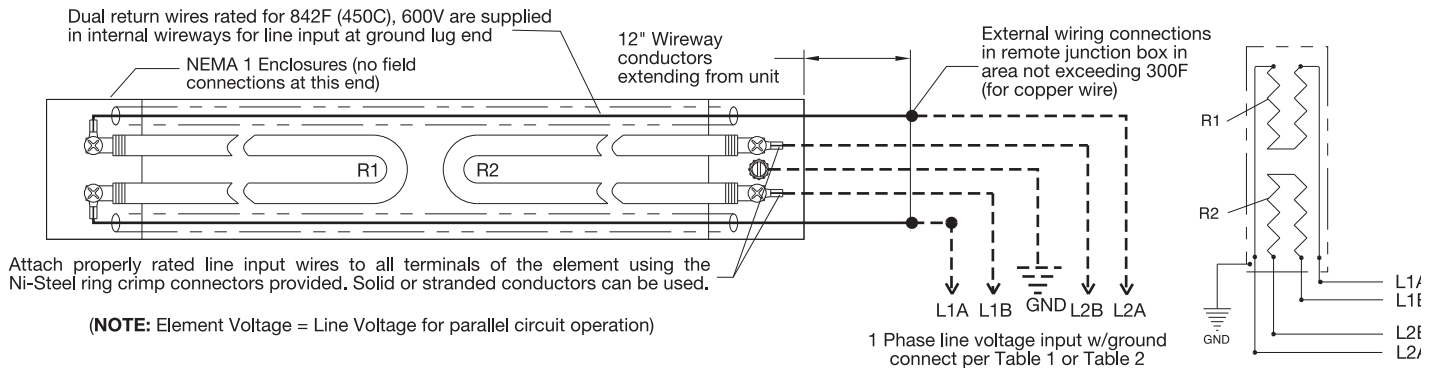

TABLE 1

Multiple Heat Connections (Single Input Voltage)

Heat Range	Line Input Wiring
Max Heat	L1A & L1B to L2A & L2B in parallel
Medium Heat	L1A to L1B or L2A to L2B only
Low Heat	L1A to L1B, input L2A to L2B

TABLE 2

Dual Voltage Connections (for 240/480V or 120/240V rated units)

Input Voltage	Line Input Wiring
High (480 or 240V)	L1A to L1B, input L2A to L2B
Low (240 or 120V)	L1A & L1B to L2A & L2B in parallel

Type ART Tubular Radiant Heater Arrays

Tempco can design and manufacture a custom tubular heater array to your specifications. Call for details.



Standard Universal Heater Replacements

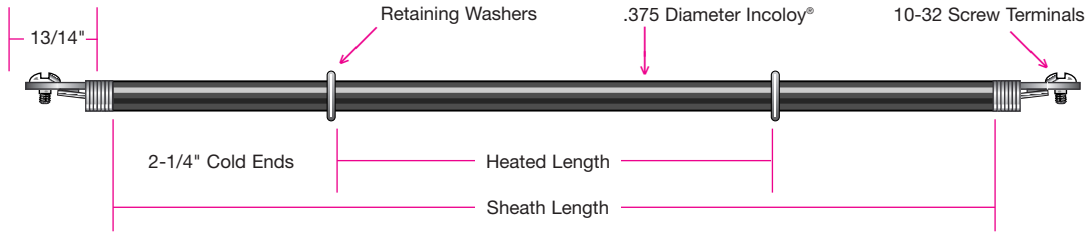

Straight Elements Standard Sizes and Electrical Ratings/Universal Replacement Cross Reference

Watts	Volts	Overall Length in.	Heated Length in.	Cold Ends in.	Watlow® No.	Chromalox® Catalog No.	PCN	TEMPCO Part Number
400	120	10 ¹ / ₄	7 ¹ / ₄	1 ¹ / ₂	RDN10E1	RTU-2063AX35	147766	THE04300
650	120	16 ³ / ₈	13 ³ / ₈	1 ¹ / ₂	RDN16L1	RTU-2063AX29	147774	THE04301
800	120	21 ¹ / ₁₆	16 ³ / ₁₆	2 ¹ / ₈	RDN21B1	RTU-2083A	106112	THE04302
800	208	21 ¹ / ₁₆	16 ³ / ₁₆	2 ¹ / ₈	RDN21B2	RTU-2083AV	106120	THE04303
800	240	21 ¹ / ₁₆	16 ³ / ₁₆	2 ¹ / ₈	RDN21B10	RTU-2083A	106139	THE04304
800	277	21 ¹ / ₁₆	16 ³ / ₁₆	2 ¹ / ₈	RDN21B4	RTU-2083AV	106147	THE04305
1100	120	27 ¹ / ₈	22 ¹ / ₈	2 ¹ / ₈	RDN27C1	RTU-3113A	106155	THE04306
1100	208	27 ¹ / ₈	22 ¹ / ₈	2 ¹ / ₈	RDN27C2	RTU-3113AV	106163	THE04307
1100	240	27 ¹ / ₈	22 ¹ / ₈	2 ¹ / ₈	RDN27C10	RTU-3113A	106171	THE04308
1100	277	27 ¹ / ₈	22 ¹ / ₈	2 ¹ / ₈	RDN27C4	RTU-3113AV	106180	THE04309
1300	240	32 ¹ / ₈	27 ¹ / ₈	2 ¹ / ₈	RDN32C10	RTU-3133A	108409	THE04310
1300	480	32 ¹ / ₈	27 ¹ / ₈	2 ¹ / ₈	RDN32C11	RTU-3133A	108396	THE04311
1800	208	42 ¹ / ₈	38 ¹ / ₈	2 ¹ / ₈	RDN42R2	RTU-4183AV	106198	THE04312
1800	240	42 ¹ / ₈	38 ¹ / ₈	2 ¹ / ₈	RDN42R10	RTU-4183A	106200	THE04314
1800	277	42 ¹ / ₈	38 ¹ / ₈	2 ¹ / ₈	RDN42R4	RTU-4183AV	106219	THE04315
1800	480	42 ¹ / ₈	38 ¹ / ₈	2 ¹ / ₈	RDN42R11	RTU-4183A	106227	THE04316
2500	208	57 ¹ / ₂	53 ¹ / ₄	2 ¹ / ₈	RDN57J2	RTU-5253AV	106235	THE04317
2500	240	57 ¹ / ₂	53 ¹ / ₄	2 ¹ / ₈	RDN57J10	RTU-5253A	106243	THE04318
2500	277	57 ¹ / ₂	53 ¹ / ₄	2 ¹ / ₈	RDN57J4	RTU-5253AV	106251	THE04319
2500	480	57 ¹ / ₂	53 ¹ / ₄	2 ¹ / ₈	RDN57J11	RTU-5253A	106260	THE04320
3000	208	69 ¹ / ₄	65	2 ¹ / ₈	RDN69E2	RTU-6303AV	106278	THE04321
3000	240	69 ¹ / ₄	65	2 ¹ / ₈	RDN69E10	RTU-6303A	106286	THE04322
3000	277	69 ¹ / ₄	65	2 ¹ / ₈	RDN69E4	RTU-6303AV	106294	THE04323
3000	480	69 ¹ / ₄	65	2 ¹ / ₈	RDN69E11	RTU-6303A	106307	THE04324
3600	208	81 ¹ / ₄	77	2 ¹ / ₈	RDN81E2	RTU-7363AV	106315	THE04325
3600	240	81 ¹ / ₄	77	2 ¹ / ₈	RDN81E10	RTU-7363A	106323	THE04326
3600	277	81 ¹ / ₄	77	2 ¹ / ₈	RDN81E4	RTU-7363AV	106331	THE04327
3600	480	81 ¹ / ₄	77	2 ¹ / ₈	RDN81E11	RTU-7363A	106340	THE04328
4000	240	109 ¹ / ₄	105	2 ¹ / ₈	RDN109E10	RTU-7303AX10	106358	THE04329
5000	240	134 ¹ / ₂	127 ¹ / ₄	3 ³ / ₈	RDN134J10	RTU-7303AX13	106366	THE04330
5500	240	153 ³ / ₈	145 ³ / ₈	4	RDN153R10	RTU-7303AX9A	106374	THE04331
6500	240	179 ¹ / ₄	171 ¹ / ₄	4	RDN179E10	RTU-7363AX38	106382	THE04332

Ordering Information

Select the Part Number of the replacement Tubular Element that meets your requirement.
Standard lead time is 2 to 3 weeks.

⚠ WARNING: Cancer and Reproductive Harm - www.P65Warnings.ca.gov.



Standard Universal Heater Replacements

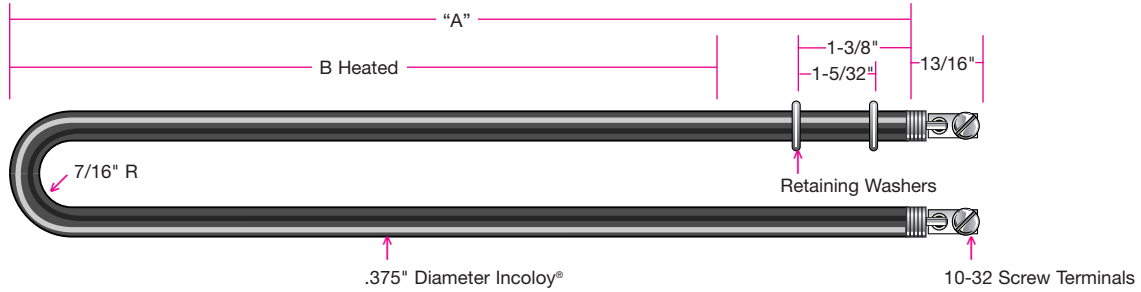

**Universal "U" Bend Elements
Standard Sizes and
Electrical Ratings Replacement
Cross Reference Listing**

Watts	Volts	Overall "A" Dim. in.	Heated "B" Dim. in.	Watlow® No.	Chromalox® Catalog No.	PCN	TEMPCO Part Number
800	120	10½	8¾	RDN21B1U	UTU-2	106438	THE04333
800	240	10½	8¾	RDN21B10U	UTU-2	106454	THE04334
800	277	10½	8¾	RDN21B4U	UTU-2V	106462	THE04335
1100	120	13¾	11¼	RDN27C1U	UTU-3	106470	THE04336
1100	208	13¾	11¼	—	UTU-3V	106489	THE04350
1100	240	13¾	11¼	RDN27C10U	UTU-3	106497	THE04337
1100	277	13¾	11¼	RDN27C4U	UTU-3V	106500	THE04338
1800	208	21¾	19¾	RDN42R2U	UTU-4V	106518	THE04339
1800	240	21¾	19¾	RDN42R10U	UTU-4	106526	THE04340
1800	480	21¾	19¾	RDN42R11U	UTU-4	106542	THE04341
2500	208	28¼	26¼	RDN57J2U	UTU-5V	106550	THE04342
2500	240	28¼	26¼	—	UTU-5	106569	THE04351
2500	277	28¼	26¼	RDN57J4U	UTU-5V	106577	THE04343
2500	480	28¼	26¼	RDN57J11U	UTU-5	106585	THE04344
3000	240	34¾	32¾	RDN69E10U	UTU-6	106606	THE04345
3000	480	34¾	32¾	RDN69E11U	UTU-6	106622	THE04346
3600	208	40¾	38¾	—	UTU-7V	106630	THE04352
3600	240	40¾	38¾	RDN81E10U	UTU-7	106649	THE04347
3600	277	40¾	38¾	RDN81E4U	UTU-7V	106657	THE04348
3600	480	40¾	38¾	RDN81E11U	UTU-7	106665	THE04349

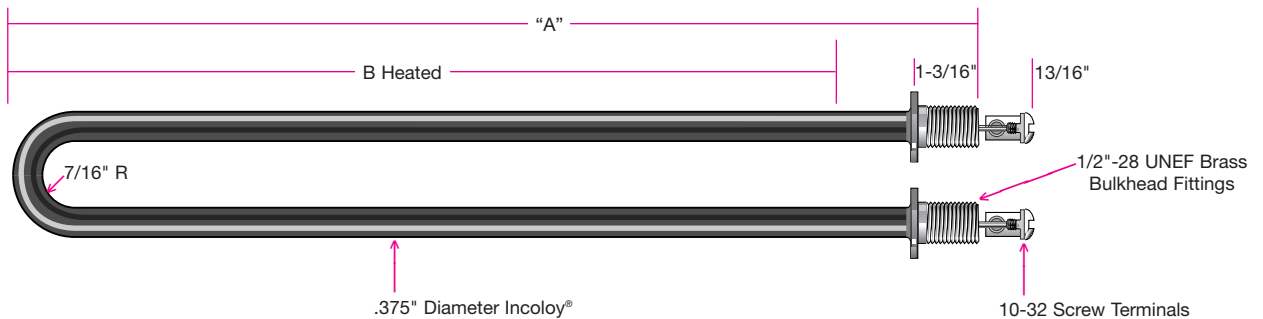

**"U" Bend Elements with
Liquid Tight Bulkhead Fittings
Standard Sizes and Electrical
Ratings Replacement Cross
Reference Listing**

Watts	Volts	Overall "A" Dim. in.	Heated "B" Dim. in.	Watlow® No.	Chromalox® Catalog No.	PCN	TEMPCO Part Number
800	120	10½	8¾	RDN21B1B	UTU-2LT	106673	THE04353
800	240	10½	8¾	RDN21B10B	UTU-2LT	106681	THE04354
1100	120	13¾	11¼	RDN27C1B	UTU-3LT	106690	THE04355
1100	240	13¾	11¼	RDN27C10B	UTU-3LT	106702	THE04356
1800	240	21¾	19¾	RDN42R10B	UTU-4LT	106710	THE04357
1800	480	21¾	19¾	RDN42R11B	UTU-4LT	106729	THE04358
2500	240	28¼	26¼	RDN57J10B	UTU-5LT	106737	THE04359
2500	480	28¼	26¼	RDN57J11B	UTU-5LT	106745	THE04360
3000	240	34¾	32¾	RDN69E10B	UTU-6LT	106753	THE04361
3000	480	34¾	32¾	RDN69E11B	UTU-6LT	106761	THE04362
3600	240	40¾	38¾	RDN81E10B	UTU-7LT	106770	THE04363
3600	480	40¾	38¾	RDN81E11B	UTU-7LT	106788	THE04364

Infrared Medium Wave Panel Heaters

4 EMITTER FACE CONSTRUCTION STYLES

*Will Accommodate a Diverse Selection
of Process Heating Applications
Requiring the Advantages of
Medium Wave Infrared Heating*



Energy Efficient
80% of the Radiant
Energy is Transmitted to the Process

Rugged Construction
Excellent Durability
Life Expectancy of up to 25,000 Hours

Direct Retrofits for Existing Applications and Custom Design/Engineering for New Applications

Rugged Construction for Trouble Free Service

Panel Infrared Heaters are available in a complete range of standard emitter face construction styles, sizes, electrical ratings and watt densities (watts/in²) with optional thermowell only or including a type J or K thermocouple.

Ordering information and product selection can be found on pages 7-89 through 7-95.

Experience the Tempco Advantage

Panel Infrared Heaters shown on this page are a small representation of the many Custom Engineered and Manufactured designs we have produced.

If you have a special application and need free technical assistance, consult our team of professionals with your requirements.

We Welcome Your Inquiries

Infrared Medium Wave Panel Heater Construction Styles

Style RPB
Black Quartz
Composite Face



High Emissivity Coating
(See page 7-90)

Style RPG
Black Glass Face



Cleanable Glass Surface
(See page 7-91)

Style RPW
High Temperature
Ceramic Glass Face



Highest Watt Density
(See page 7-92)

Style RPM
Metal Face



Cleanable Metal Surface
(See page 7-93)

Construction Characteristics

The placement of the resistance coils is carefully designed to provide uniform heat distribution.

The refractory material is backed by layers of insulation to minimize back heat loss. The standard housing is made of heavy gauge aluminized steel. Optional housing materials include 304 Stainless Steel.

The backside of the housing has a terminal box for electrical wiring with ceramic terminal bushings and stainless steel screw terminals.

Options available include: Standard quartz tube thermowell and clamp on the short side, standard Type K or J 1/8" diameter thermocouple probes and various back mounted thermowell/thermocouple combinations described on page 7-95.



DANGER: Fire Hazard

Infrared Panel Heaters are not to be used in applications where flammable vapors, gases or combustible materials are present as defined in the National Electrical Code. Do not mount the heater closer than 6 inches to any structural or surrounding material that does not have a minimum temperature rating of continuous operation at 395°F (200°C). Proper ventilation is required to expel vapors or fumes away from the process and personnel.

Design Features

- * Available in convenient standard building block sizes
- * Standard mounting screw studs (1/4-20 x 1"L) on the back side
- * Available in four emitter face styles
- * Can be ordered with standard side mounted thermowell, clamp bracket and/or Type J or K thermocouple
- * 3 different back mounted thermowell/thermocouples are available
- * Does not require external reflectors, which require maintenance
- * Voltages available include 120, 240, 480 VAC, 1 or 3 phase, dual voltage and custom
- * Maximum watt densities from 25 to 40 watts /in²
- * Multiple zones and distributed wattage in the same panel heater
- * Uniform infrared heating coverage
- * Stainless Steel power screw terminals



Note:

Not hermetically sealed.

Ordering Information

Catalog Heaters

To order a **Radiant Panel** from the tables on the following pages, fill in the last digit of the part number indicating built-in thermowell and thermocouple as follows:

- 0** = Plain, no thermowell or T/C
- 1** = Thermowell only
- 2** = Thermowell and type K T/C
- 3** = Thermowell and type J T/C

If a thermowell is selected, specify the type from page 7-95

Custom Engineered/Manufactured Heaters

Understanding that an electric heater can be very application specific, for sizes and ratings not listed, Tempco can manufacture a Radiant Panel Heater to meet your requirements. **Standard lead time is 4 weeks.**

Please Specify the following:

- Construction Style (RPB, RPG, RPW or RPM)
- Length and Width
- Watts, Volts and Phase
- Thermowell Type only
- Thermowell and Type K or J Thermocouple

⚠ WARNING: Cancer and Reproductive Harm - www.P65Warnings.ca.gov.

Style RPB Panel Heater

Style RPB Black Quartz Composite Face Infrared Panel Heaters



Design Features

- * Panel heater can be mounted in any direction
- * High temperature black quartz composite face
- * High temperature black coating
- * Precision wound resistance wire
- * Heavy gauge aluminized steel enclosure box standard
Optional: 304 Stainless Steel
- * Optional: quartz thermowell tube
Standard: side mount with clamp
Optional-3 back mounted styles
- * Refractory blanket insulation
- * Stainless Steel power screw terminals
- * Mounting screw studs
Standard: 1/4-20 x 1"L
- * Electrical junction box, standard

Construction Characteristics

Tempco Style RPB panel infrared heaters have a woven silica quartz composite surface that is transparent to radiant energy and is coated with a high temperature black coating for high emissivity.

The resistance wire is helically wound from a high temperature iron/chromium/aluminum alloy. A uniform pattern across the face is milled out in the high temperature ceramic fiberboard, and the resistance coil is cemented in place. Refractory blanket insulation backs up the fiberboard face assembly.

Tempco Style RPB Radiant Heaters can transmit up to 79.5% of the input energy and can be positioned as close as 2 to 4" from the material being heated.

Typical Applications

- ↔ Thermoforming
- ↔ Paint Drying
- ↔ Ink Drying
- ↔ Curing of Plastic Coatings
- ↔ Silk Screen Painting
- ↔ Food Warming
- ↔ Laminating

SPECIFICATIONS

Maximum Size: In addition to the standard sizes listed below; custom sizes up to 30"W x 84"L can be manufactured.

Thickness: Standard — 3", Optional — 1.5" to 5"

Maximum Watt Density: 25 Watts/in²

Maximum Voltage: Voltage can be single, dual or 3-phase up to 600 VAC (depending on heater size and wattage)

Maximum Face Temperature: 900°C (1652°F)

Wavelength Range: Between 2.5 and 6.0 microns (μm)

Distributed Wattage and Zoning: Yes, dependent on size

Infrared / Convection Radiant Panels

RPB Radiant Panels can also be supplied for combination radiant/convection applications. Holes are drilled in a uniform pattern in the face of the panel to allow air flow from the rear plenum. A 3" hole is typically provided in the rear panel for mounting a blower or ductwork. Submit your requirements to Tempco.

Standard (Non-Stock) Sizes and Ratings of Style RPB Black Face Infrared Heaters

To complete the part numbers below, include the designated number that applies to the following options:

0 = Plain, no thermowell or T/C **1** = Thermowell only **2** = Thermowell and type K T/C **3** = Thermowell and type J T/C

Available Thermowell/Thermocouple types and descriptions can be found on page 7-95.

For the part numbers below, if a thermowell is specified, the standard Side Mount Thermowell with Clamp is supplied.

Width		Length		15W/in ²			Part Number	25W/in ²			Part Number
in	mm	in	mm	Watts	Volts	Ph.		Watts	Volts	Ph.	
6	152	12	305	1080	120	1	RPB0101__	1800	240/480	1	RPB0201__
6	152	18	457	1620	240	1	RPB0102__	2700	240/480	1	RPB0202__
6	152	24	610	2160	240/480	1	RPB0103__	3600	240/480	1	RPB0203__
6	152	30	762	2700	240/480	1	RPB0104__	4500	240/480	1	RPB0204__
12	305	12	305	2160	240/480	1	RPB0107__	3600	240/480	1	RPB0207__
12	305	18	457	3240	240/480	1	RPB0108__	5400	240/480	1	RPB0208__
12	305	24	610	4320	240/480	1	RPB0109__	7200	240	3	RPB0209__
12	305	30	762	5400	240/480	1	RPB0110__	9000	240	3	RPB0210__
12	305	36	914	6480	240	3	RPB0111__	10800	480	3	RPB0211__
12	305	48	1219	8640	240	3	RPB0112__	14400	480	3	RPB0212__
18	457	18	457	4860	240/480	1	RPB0117__	8100	240	3	RPB0217__
24	610	24	610	8640	240	3	RPB0118__	14400	480	3	RPB0218__



Style RPG High Temperature Glass Face Infrared Panel Heaters



Design Features

- * Panel heater can be mounted in any direction
- * High temperature transparent red/black glass emitter face
- * Precision wound resistance wire
- * Milled ceramic fiberboard to hold resistance wire, cemented in place
- * Heavy gauge aluminized steel enclosure box standard
Optional: 304 Stainless Steel
- * Optional: quartz thermowell tube
Standard: side mount with clamp
Optional-3 back mounted styles
- * Refractory blanket insulation
- * Stainless Steel power screw terminals
- * Mounting screw studs
Standard: 1/4-20 x 1" L
- * Electrical junction box, standard

Construction Characteristics

The Tempco Style RPG Radiant Panel Heater has a red/black high temperature ceramic glass for the exterior radiant surface. The RPG Radiant Panel Heater is the ideal heater when a cleanable surface is required, such as for the bottom heaters of a thermoforming oven.

Behind the glass, a 1" thick ceramic fiberboard is milled out to support the helically wound iron/chromium/aluminum alloy based resistance element. The resistance coils are placed into the precision machined grooves in the fiberboard and cemented into place. Ceramic cloth is placed between the glass and the resistance coil.

Tempco Style RPG Radiant Heaters can transmit up to 78.5% of the input energy and can be positioned as close as 2 to 4" from the material being heated.

Typical Applications

- ➔ Moisture Removal
- ➔ Paint Drying
- ➔ Glass Processing
- ➔ Curing of plastic coatings, paint, ink, etc.
- ➔ Thermoforming
- ➔ Heat Setting
- ➔ Film Shrinking
- ➔ Blister Packaging
- ➔ Food Processing
- ➔ Textile Drying

SPECIFICATIONS

Maximum Size: In addition to the standard sizes listed below; custom sizes up to 34"W x 36"L can be manufactured.

Thickness: Standard — 3", Optional — 1.5" to 5"

Maximum Watt Density: 20 Watts/in²

Maximum Voltage: Voltage can be single, dual or 3-phase up to 600 VAC (depending on heater size and wattage)

Maximum Face Temperature: 750°C (1382°F)

Wavelength Range: Between 2.5 and 6.0 microns (μm)

Distributed Wattage and Zoning: Yes, dependent on size

Standard (Non-Stock) Sizes and Ratings of Style RPG High Temperature Glass Infrared Heaters

To complete the part numbers below, include the designated number that applies to the following options:

0 = Plain, no thermowell or T/C **1** = Thermowell only **2** = Thermowell and type K T/C **3** = Thermowell and type J T/C
Available Thermowell/Thermocouple types and descriptions can be found on page 7-95.

For the part numbers below, if a thermowell is specified, the standard Side Mount Thermowell with Clamp is supplied.

Width		Length		10W/in ²				15W/in ²			
in	mm	in	mm	Watts	Volts	Ph.	Part Number	Watts	Volts	Ph.	Part Number
6	152	12	305	720	120	1	RPG0101__	1080	120/240	1	RPG0201__
6	152	18	457	1080	120/240	1	RPG0102__	1620	240	1	RPG0202__
6	152	24	610	1440	120/240	1	RPG0103__	2160	240/480	1	RPG0203__
12	305	12	305	1440	120/240	1	RPG0104__	2160	240/480	1	RPG0204__
12	305	18	457	2160	240/480	1	RPG0105__	3240	240/480	1	RPG0205__
12	305	24	610	2880	240/480	1	RPG0106__	4320	240/480	1	RPG0206__
16	406	24	610	3840	240/480	1	RPG0107__	5760	240/480	1	RPG0207__
24	610	24	610	5760	240	1	RPG0108__	8640	480	1	RPG0208__

Style RPW Panel Heater

Style RPW Very High Temperature Ceramic Glass Face Infrared Panel Heaters



Design Features

- * Panel heater can be mounted in any direction
- * High temperature white translucent glass emitter surface
- * Precision wound resistance wire
- * Milled ceramic fiberboard to hold resistance wire, cemented in place
- * Heavy gauge aluminized steel enclosure box standard
Optional: 304 Stainless Steel
- * Optional: quartz thermowell tube
Standard: side mount with clamp
Optional-3 back mounted styles
- * Refractory blanket insulation
- * Stainless Steel power screw terminals
- * Mounting screw studs
Standard: 1/4-20 × 1"L
- * Electrical junction box, standard

Construction Characteristics

Tempco Style RPW Radiant Panel Heaters use a very high temperature ceramic glass for the emitter surface. The RPW Radiant Panel Heater is the perfect heater when a cleanable surface is required at a higher watt density.

Behind the very high temperature glass, a 1" thick ceramic fiber refractory board is milled out in a uniform pattern to accept the helically wound iron/chromium/aluminum alloy resistance element. The resistance coils are set into the precision machined grooved board and cemented into place. A ceramic cloth is placed between the very high temperature glass and the resistance coils.

Tempco Style RPW Radiant Heaters can transmit up to 78.5% of the power input as infrared energy.

Typical Applications

- ↔ Moisture Removal
- ↔ Paint Drying
- ↔ Glass Processing
- ↔ Curing of plastic coatings, paint, ink, etc.
- ↔ Thermoforming
- ↔ Heat Setting
- ↔ Film Shrinking
- ↔ Blister Packaging
- ↔ Food Processing
- ↔ Toasting
- ↔ Textile Drying

SPECIFICATIONS

Maximum Size: In addition to the standard sizes listed below; custom sizes up to 24"W × 24"L can be manufactured.

Thickness: Standard — 3", Optional — 1.5" to 5"

Maximum Watt Density: 40 Watts/in²

Maximum Voltage: Voltage can be single, dual or 3-phase up to 600 VAC (depending on heater size and wattage)

Maximum Face Temperature: 800°C (1472°F)

Wavelength Range: Between 2.5 and 6.0 microns (μm)

Distributed Wattage and Zoning: Yes, dependent on size

Standard (Non-Stock) Sizes and Ratings of Style RPW Very High Temperature Glass Infrared Heaters

To complete the part numbers below, include the designated number that applies to the following options:

0 = Plain, no thermowell or T/C **1** = Thermowell only **2** = Thermowell and type K T/C **3** = Thermowell and type J T/C
Available Thermowell/Thermocouple types and descriptions can be found on page 7-95.

For the part numbers below, if a thermowell is specified, the standard Side Mount Thermowell with Clamp is supplied.

Width		Length		40W/in ²			Part Number
in	mm	in	mm	Watts	Volts	Ph.	
4	102	10	254	1600	240	1	RPW0101__
6	152	10	254	2400	240/480	1	RPW0102__
6	152	12	305	2880	240/480	1	RPW0103__
8	203	10	254	3200	240/480	1	RPW0104__
10	254	10	254	4000	240/480	1	RPW0105__
12	305	10	254	4800	240/480	1	RPW0106__
12	305	12	305	5760	240/480	1	RPW0107__



Style RPM Metal Face Infrared Panel Heaters



Design Features

- * Panel heater can be mounted in any direction
- * Metal emitter face
Stainless steel with black finish
- * Precision wound resistance wire
- * Milled ceramic fiberboard to hold resistance wire, cemented in place
- * Heavy gauge aluminized steel enclosure box standard
Optional: 304 Stainless Steel
- * Optional: quartz thermowell tube
Standard: side mount with clamp
Optional-3 back mounted styles
- * Refractory blanket insulation
- * Stainless Steel power screw terminals
- * Mounting screw studs
Standard: 1/4-20 x 1"L
- * Electrical junction box, standard

Construction Characteristics

Tempco Style RPM Radiant Panel Heaters have a stainless steel metal with a black finish for the emitter surface. The RPM Radiant Panel Heater is a good heater when a cleanable surface and a robust design is required.

The ceramic fiber refractory board is milled out in a uniform pattern to accept the helically wound iron/chromium/aluminum alloy resistance element. The resistance coils are set into the precision machined grooved board and cemented into place. A ceramic cloth is placed between the metal face and the resistance coils.

Tempco Style RPM Radiant Heaters can transmit up to 65.0% of the power input as infrared energy. They can be positioned as close as 2 to 4" from the material being heated.

Typical Applications

- ➔ Thermoforming
- ➔ Paint Drying
- ➔ Ink Drying
- ➔ Curing of Plastic Coatings
- ➔ Silk Screen Painting
- ➔ Food Warming
- ➔ Heat Setting
- ➔ Film Shrinking
- ➔ Blister Packaging

SPECIFICATIONS

Maximum Size: In addition to the standard sizes listed below, custom sizes up to 24"W x 48"L can be manufactured.

Thickness: Standard — 3", Optional — 1.5" to 5"

Maximum Watt Density: 15 Watts/in²

Maximum Voltage: Voltage can be single, dual or 3-phase up to 600 VAC (depending on heater size and wattage)

Maximum Face Temperature: 700°C (1292°F)

Wavelength Range: Between 3.0 and 6.0 microns (μm)

Distributed Wattage and Zoning: Yes, dependent on size

Standard (Non-Stock) Sizes and Ratings of Style RPM Metal Face (SS) Infrared Heaters

To complete the part numbers below, include the designated number that applies to the following options:

0 = Plain, no thermowell or T/C **1** = Thermowell only **2** = Thermowell and type K T/C **3** = Thermowell and type J T/C
Available Thermowell/Thermocouple types and descriptions can be found on page 7-95.

For the part numbers below, if a thermowell is specified, the standard Side Mount Thermowell with Clamp is supplied.

Width		Length		10W/in ²			15W/in ²			Part	
in	mm	in	mm	Watts	Volts	Ph.	Part Number	Watts	Volts	Ph.	Part Number
6	152	12	305	720	120	1	RPM0101__	1080	120/240	1	RPM0201__
6	152	18	457	1080	120/240	1	RPM0102__	1620	240	1	RPM0202__
6	152	24	610	1440	120/240	1	RPM0103__	2160	240/480	1	RPM0203__
12	305	12	305	1440	120/240	1	RPM0104__	2160	240/480	1	RPM0204__
12	305	18	457	2160	240/480	1	RPM0105__	3240	240/480	1	RPM0205__
12	305	24	610	2880	240/480	1	RPM0106__	4320	240/480	1	RPM0206__
16	406	24	610	3840	240/480	1	RPM0107__	5760	240/480	1	RPM0207__
24	610	24	610	5760	240	1	RPM0108__	8640	480	1	RPM0208__

Infrared Medium Wave Panel Heater Warm-Up Curves

Warm-up curves are measured from heaters running facedown in open air. The thermocouple is located in the standard location, in the thermowell located behind the coil. The curves will change with environment and thermocouple location.

The curves are also useful in determining what the potential maximum temperature and peak wavelength are for various watt density heaters.

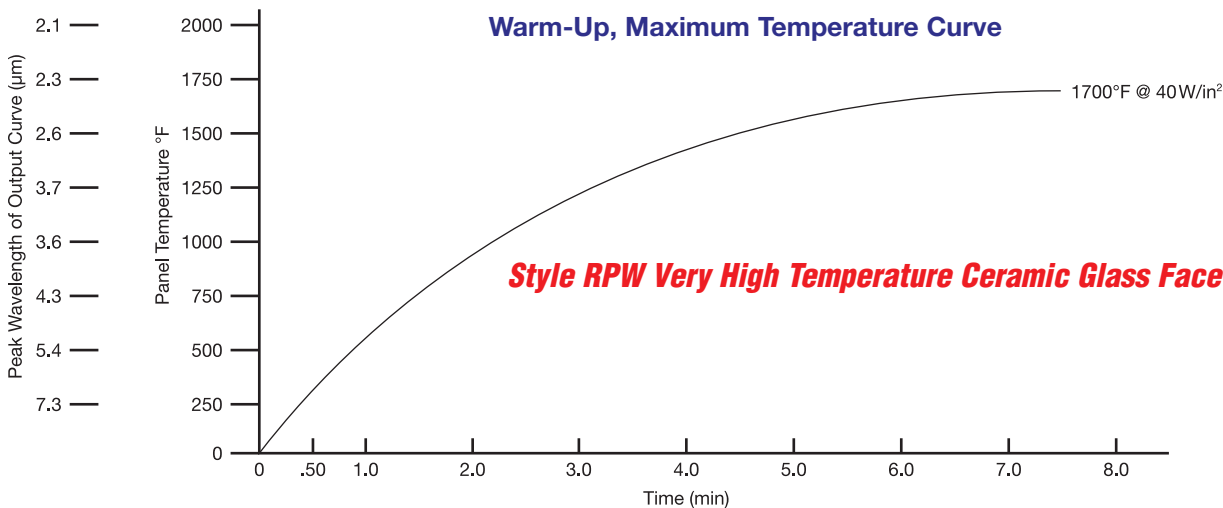
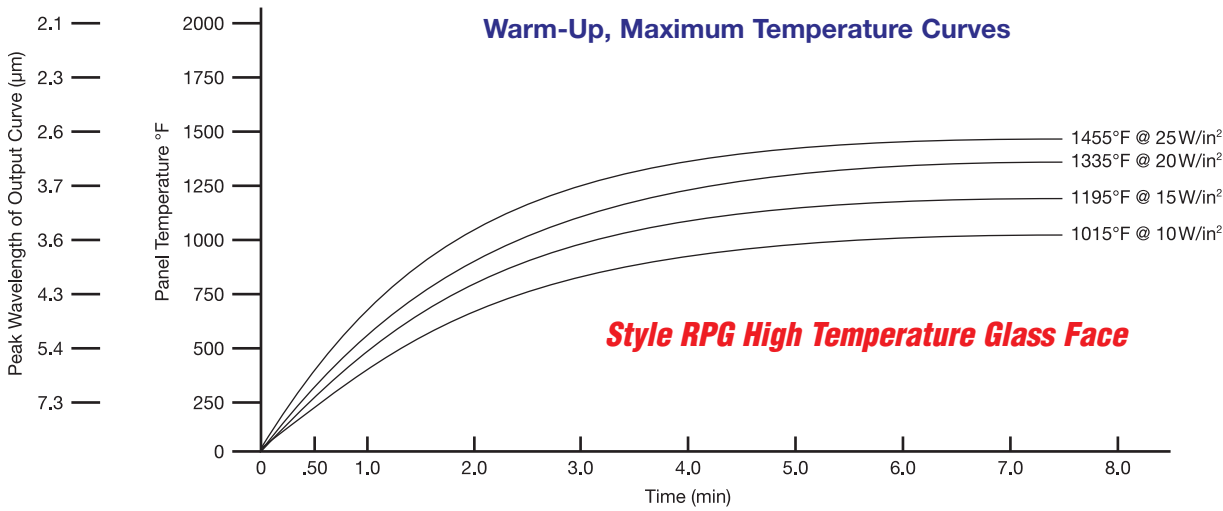
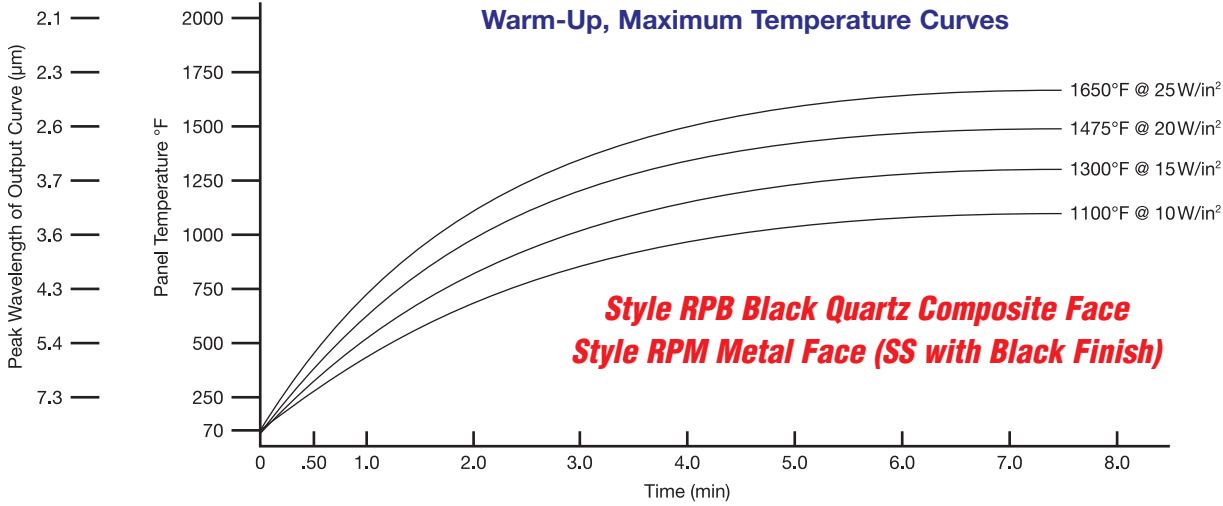

Infrared Panel Heater Options

Construction Options

The standard enclosure case is aluminized steel. Aluminized steel is the optimum choice for most applications. It will reach 650°C/1200°F without discoloring or degrading.

304 Stainless Steel is available when cleanliness is of the utmost importance. (Note: 304 SS will discolor at a lower temperature than aluminized steel).

Rivets are normally used to hold the case together. In addition to the side slots, this allows for expansion/contracting of the case and minimizes potential warping. There are applications that require minimal potential particulate matter. For these applications the side slots are not put in and the metal seams can be welded closed.



Thermowell/Thermocouple Temperature Sensing Options

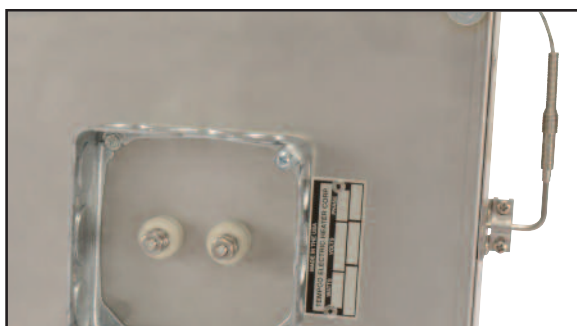

Standard Side Mount Thermowell with Clamp

The standard Side Mount Thermowell with Clamp is a 5" long, 4 mm ID quartz glass tube, installed in the short side of the panel, just behind the resistance coil. The screw pressure clamp and thermowell are designed to hold a 0.125" diameter probe.

Replacement TC Probes (with 48" leads, SS overbraid)

Type K — Part Number MTA00839

Type J — Part Number MTA00840

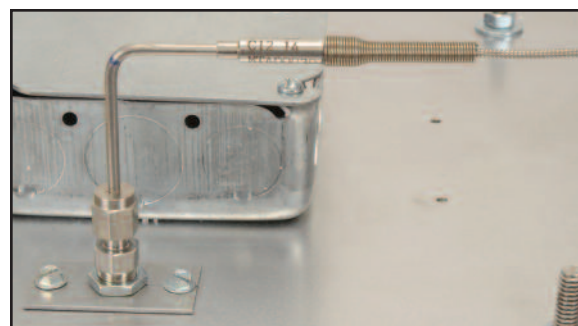

Back Mount Thermowell with Compression Fitting

The optional Back Mount Thermowell with Adjustable Compression Fitting is a short, 4 mm ID quartz glass tube, mounted perpendicular to the face with a ceramic disk at the bottom. The compression fitting and glass tube are sized for a 0.125" diameter probe.

Replacement TC Probes (with 48" leads, SS overbraid)

Type K — Part Number MTA00839

Type J — Part Number MTA00840

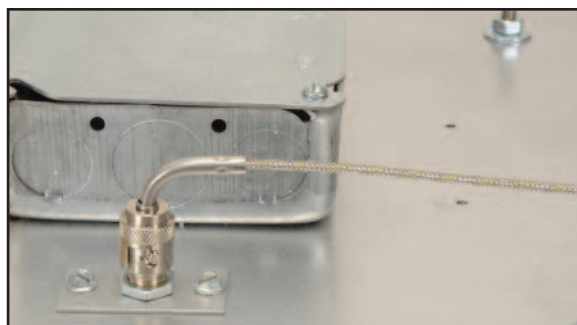

Back Mount Thermowell with Bayonet Fitting

The optional Back Mount Thermowell with Bayonet Fitting is a short, 8 mm ID quartz glass tube, mounted perpendicular to the face with a ceramic disk at the bottom. The bayonet fitting and glass tube are sized for a 0.187" diameter probe.

Replacement TC Probes (with 48" leads, SS overbraid)

Type K — Part Number TCP50270

Type J — Part Number TCP50269

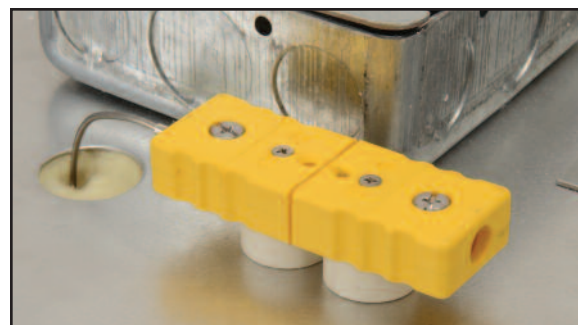

Back Mount Thermowell – Parallel to Face

The optional Back Mount Thermowell (Parallel to Face) is a 5", 6 mm ID quartz glass tube with a soft 90° bend, mounted along the face, exiting in the rear. A maximum 0.063" diameter probe is required to make the bend. Screws and ceramic spacers are provided.

Replacement TC Probes (with connector set)

Type K — Part Number MTA01546

Type J — Part Number MTA01775

Introduction to Infrared Radiation

Infrared Radiant Heaters Are Ideal for Many Diverse Applications

Plastics and Rubber

- *Plastifying of plastic sheets and rolls for thermoforming and vacuum forming*
- *Preheating or vulcanizing rubber sheets*
- *Heating glass fiber reinforced plastic during production*
- *Curing plastisols*
- *Laminating and plastic welding*

Paper/Pulp

- *Drying of paper pulp*
- *Quick drying of gummed, sized, or lacquered paper*
- *Drying of unprocessed and printed wallpaper*
- *Heating papier-mâché before pressing*
- *Adhesive activation*

Textiles

- *Setting Nylon® and Perlon® threads*
- *Gelling PVC paste coatings on fabrics*
- *Drying washed, dyed, and finished textile fabrics*
- *Heat set synthetic fabrics*

Food

- *Baking and browning small bakery products*
- *Keeping food warm*
- *Heating processed cheeses*
- *Packaging food products*

Miscellaneous Processes

- *Drying and curing of paint and powder coatings*
- *Drying raw tobacco*
- *Evaporation of water and solvents*
- *Manufacturing shrink packaging equipment*
- *Ink drying*
- *Comfort heat for agricultural, zoological and reptilian pet applications*

Introduction to Infrared Radiation Heating Systems

Tempco's Radiant Heaters

fall into the medium wavelength range of electromagnetic infrared radiation. Infrared energy is commonly used to heat plastics, remove moisture, cure painted finishes or heat food products. This is because plastics, organic substances and water absorb infrared energy more efficiently than other materials in industrial applications.

A Straightforward Approach to Infrared Radiant Heating Technology

Radiant heating is regarded by many as a black magic technology that is complicated and difficult to work with. While radiation theory can be complicated, it is far easier to apply when given the appropriate heating devices and guidance on which device best suits your application.

In this section, Tempco will present an overview of our product offerings, their capabilities, and relevant technical data that will aid you in selecting the heating system that best serves your requirements.

No matter what the application needs, Tempco has the right product to satisfy your requirements.

The Basics

The three main modes of heat transfer are:

Conduction – When two bodies of different temperature are brought in contact with each other, heat energy flows from the hotter to the colder body.

Convection – Heat energy is transferred from a higher temperature region in a gas or liquid to a lower temperature region as a result of movement of masses within the fluid or gas.

Radiation – Infrared radiant energy is transported through space by electromagnetic waves without the need for a conductive media. Consequently, heat can be delivered in concentrated areas at very fast rates.

Electromagnetic radiation can be further broken down into four basic categories:

1. Ultraviolet
2. Infrared – (Short/Medium/Long Wavelength)
3. Microwave
4. Radio Frequency/Induction

Operating life



A ceramic infrared E-Mitter should not be immersed in or have contact with any liquids. The E-Mitter surface must be kept clean and free of any contamination. Failure to do so can compromise heater operating life.

Explosion Protection



Ceramic Infrared Heaters are not explosion-proof heaters. These heaters can only be used in atmospheres where the vapor concentration is well below the explosion limits of the processed material. Special provisions, such as forced ventilation, must be made to remove highly flammable vapors from the heater's path. Strict observance of the drying temperature is required for enamel-based materials.

The user is solely responsible for the installation of the E-Mitters and strict observance of all applicable regulations.

Ceramic Infrared E-Mitter Technical Data

Heat Transfer Theory Summary

A heat transfer mode that will naturally occur at the surface of the heater is called radiation. Its intensity does not depend on the characteristics of the surrounding fluid (it works in a vacuum too) but on the characteristics of the heater and the surrounding bodies.

Therefore, the efficiency of radiation heat transfer exchange between bodies depends on:

1. **The emissivity values of the emitter (i.e. ceramic heaters).**
2. **The absorption, reflection and transmission properties associated with the receiving medium.**
3. **The relative temperature differences.**
4. **The surface characteristics.**
5. **Relative position and physical geometry.**

The Technical References presented here are intended to enhance your knowledge of various aspects of infrared radiant heating, enabling you to make better choices when selecting Tempco ceramic infrared E-Mitters.

Many applications in the field are unique and present substantially different operational parameters and characteristics. This application diversity should be evaluated accordingly, and while the material presented in this section is intended to provide some background reference, it is very generalized and is not to be construed as application specific.



Note: It is highly recommended that you contact our staff of knowledgeable sales engineers with specific technical questions relating to your application.

Infrared radiant energy is transported through space by electromagnetic waves without the need of a conductive media (as opposed to conduction or convection processes). Consequently, **heat can be delivered in concentrated areas at very fast rates.**

Understanding these important characteristics will lead to a better utilization of infrared heating technology.

Taking the Mystery Out of Infrared Energy

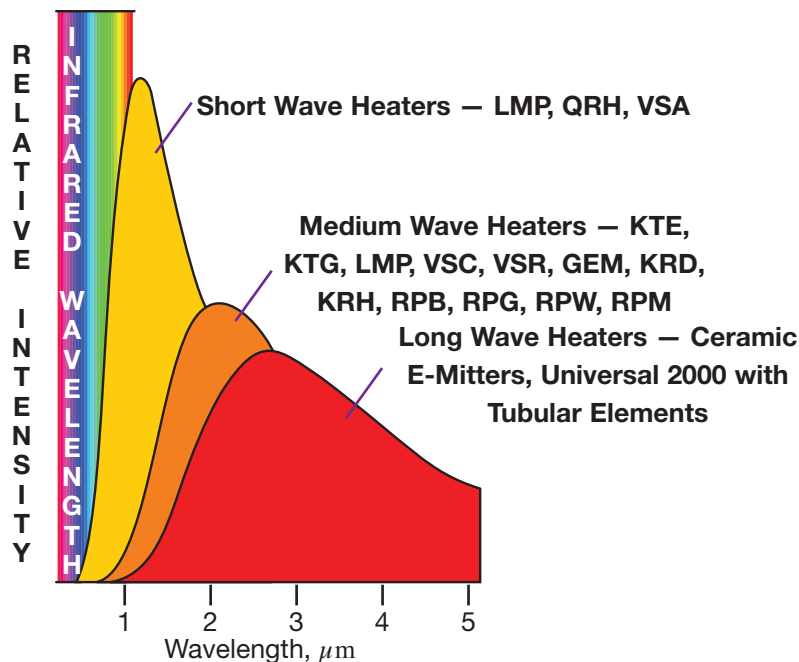

All matter emits radiant energy as a consequence of its finite temperature.

Only at absolute zero (-273°C), when all molecular activity ceases, does matter stop emitting radiant energy. In solids and liquids, emission of radiant energy is considered a surface phenomenon, while for gases and certain semi-transparent solids, such as glass and salt crystals (at elevated temperature), emission is considered a volumetric phenomenon.

WHY CAN'T WE SEE INFRARED RADIATION?

Electromagnetic radiation is measured in wavelength " λ " or in frequency " f ." Both quantities are related by the equation:

$$\lambda = c \div f$$

" c " is the speed of light (3×10^8 m/s)

Infrared radiation wavelengths fall outside the visible range in the electromagnetic spectrum; see adjacent figure. One micrometer, μm , is equal to 10^{-6} meter.

The total radiant energy " W " in watts per square centimeter emitted by an object is found with the Stefan-Boltzmann law:

$$W = \epsilon \sigma T^4$$

" ϵ " is the emissivity factor

" σ " is the Stefan-Boltzmann constant (5.67×10^{-12} W/cm 2 K 4)

" T " is the surface temperature of the object in $^{\circ}\text{K}$ (0°C equals 273°K).

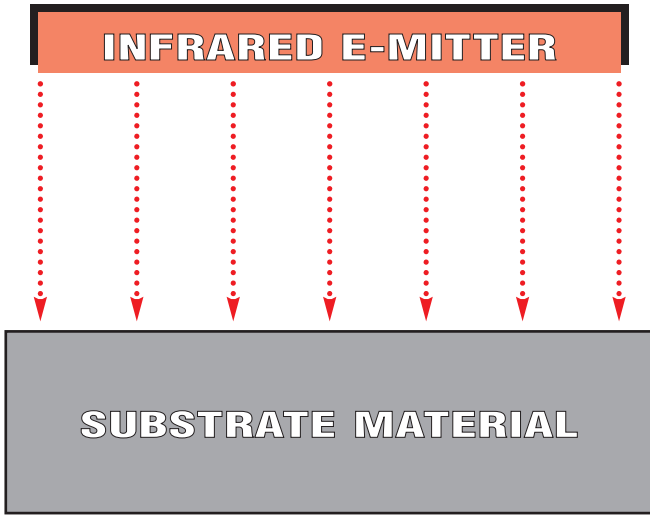

What Kind of Material Do You Want to Heat or Dry?

This information is used to compare the absorption spectra of the material with the emission spectra of the infrared heaters. A good match ensures that the radiant energy from the E-mitter will be effectively absorbed by the material with minimum losses due to transmittance or reflectance. The table below was prepared to help you select the best heater rating for your particular application. If you need additional information, contact **Tempco** for technical assistance.



In situations where the material or its released solvents/vapors are easily flammable, special protection is required. Explosion-protected types of E-Mitters are not available. You will have to take proper steps to prevent the flammable media from coming into contact with the hot heater surfaces and electrical wiring. Current regulations and electrical codes must be complied with to prevent unsafe conditions.

Examples of Common Applications

The table below presents some of the most common infrared applications encountered in several industries. The wavelength of the infrared energy was matched to the absorption characteristics of the material to be heated. Various wattages for the same appli-

cation are recommended due to the absorption characteristics and variables of the application. Select the wattage according to the application requirements. Testing is strongly recommended before final selections are made.

Industry	Wattage	CRB Infrared Heater Ratings									
		150	250	300	350	400	500	650	750	1000	
	Surface Watt Density	6.48	10.8	12.95	15.11	17.27	21.59	28.07	32.39	43.18	
PAPER											
• Heating paper pulp and papier-mâché before pressing/molding*								■			
• Quick drying of lacquered paper, gummed or glued paper and cardboard*									■	■	
PLASTICS & RUBBER											
• Drying/curing plastic/latex emulsion/surfacing*				■	■						
• Gelling PVC paste/film on fabrics etc.*				■	■						
• Preheating plastic foil/sheet/vacuum forming*				■	■	■	■	■	■	■	
• Preheating rubber sheeting prior to extrusion*						■	■				
TEXTILES, SILK & FIBERS											
• Drying washed, dyed and finished textiles*		■						■	■	■	
• Fiberglass layup and molding; Resin curing*			■	■	■						
• Silk-screen printing; Fusing metallic inks*					■	■	■			■	
• Stress curing ovens for synthetic fibers*				■	■	■	■				
TOBACCO & FOOD INDUSTRY											
• Heating food in restaurants*		■	■	■							
• Tobacco drying; Grain drying*		■	■								
GENERAL											
• Activation of adhesives and surface sealing*					■	■					
• Drying/baking lacquered tin components*			■	■	■	■	■				
• Heat/dry/fixing adhesives (boot and shoe trade)*								■	■	■	
• Low temperature drying of atomized chemicals*				■	■	■	■				
• Ore drying and sampling for laboratory work*					■	■	■				
• Preheating large metal embossing rollers*					■	■	■				
• Powder coating processes*				■	■	■	■				
• Setting Nylon® and Perlon® threads, etc.*			■	■	■	■					
• Water evaporation*		■							■	■	

How to Select a Ceramic Infrared Heater

Safe, economical and efficient infrared radiation heating systems can be designed, installed and operated by following some basic rules and guidelines.

Heating Distance for Stationary and Moving Systems

The optimum heating distance cannot be accurately determined for a given application without some preliminary testing because of the many different factors that affect the radiation transfer of heat. Therefore only general guidelines can be offered here.

In any heating application, it is recommended that Stationary Testing be done first. This can be accomplished by following some simple steps.

Stationary Testing

OBJECTIVE

Determination of the heating distance

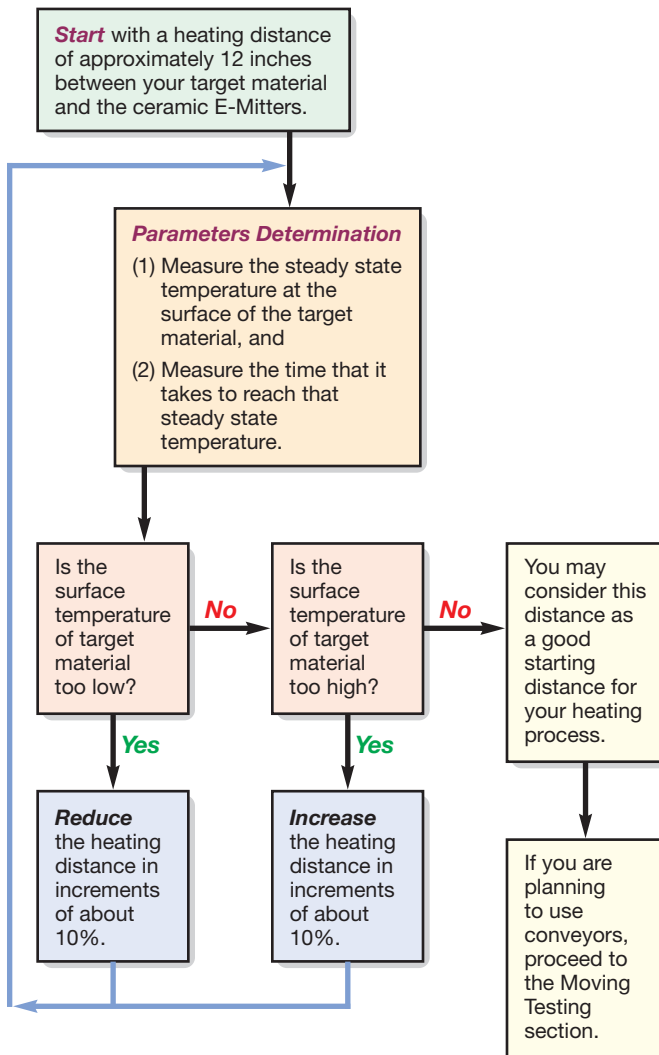

DESIGN GUIDELINE

A General Information

1. Use the table on page 7-98 to match your target material with its corresponding ceramic E-Mitter rating. If the table does not list your target material, consult Tempco for assistance.

2. Select and order the ceramic E-Mitter based on the wattage rating. Tempco offers a complete line of industrial ceramic infrared heaters for you to choose from. Other wattage and voltage combinations can be designed and manufactured to suit your particular application. Consult Tempco with your requirements.

3. Next, what heating process are you going to apply to your target material: Process Heating, Drying, Curing, Cooking or another process? **Your answer will dictate the next design guideline and how to proceed for the determination of the correct heating distance.**

DESIGN GUIDELINE

B Process Heating

In many industrial applications, heat has to be applied to a target material before being processed further. In some cases, hot spots or large temperature gradients must be avoided. For this reason, it is highly recommended that several temperature controllers be used together with ceramic E-Mitters and integrated thermocouples. Three main processes require special attention:

1. Plastic sheets The fact that plastics have very low internal thermal conductivity causes localized heating if the applied heat is not uniformly distributed or if the sheets are too thick. In this situation, it is recommended that heat be applied to both sides of the sheet for the heat to be distributed throughout the material.

2. Metallic sheets or strips Metals are better internal conductors of heat than plastics but they absorb much less radiant energy because most of it is reflected at the surface. To overcome this problem, match the emission spectra of the radiant heater with the absorption spectra of the metal. Tempco's sales engineering staff will gladly help you in this endeavor.

3. Granular form material A relatively uniform heating of granulated compounds can be achieved by placing a thin layer of granules on a vibrating surface or conveyor to aerate the material while heating.

DESIGN GUIDELINE

C Drying, Curing & Cooking

Drying involves the release of water vapor, solvents or other materials that are vaporized during the process. In some cases, the solvents may be harmful or explosive and would require special protection. The user is solely responsible for the installation of the heating system and the strict observance of all applicable regulations.

Water vaporization, on the other hand, does not present this problem, but offers other related ones that also require special handling, such as how to remove the water vapor as it comes off the material being processed.

As for **curing and cooking**, because of the many different applications encountered within various industries, no specific rules can be offered in this general guideline. Testing of the application is recommended to determine the process requirements. Contact Tempco's sales engineers if assistance is needed.

Ceramic Infrared E-Mitter Technical Data

Moving Testing

OBJECTIVES

Determination of the heating distance and the velocity of the conveyor

Tips for Infrared Heating Systems

Infrared heating works best with materials that are thin enough for the heat to be absorbed and/or when the target material has high internal thermal conductivity. In metals, for example, heat is easily conducted from the surface to the interior of the material.

Multilayer materials present some difficulties when they are to be heated with infrared heaters. The top layer dries faster than the lower layers, causing different rates of shrinkage throughout the material. Infrared heat energy is transmitted with the speed of light from the surface of an emitter source (i.e. a ceramic heater) to the surface of the target material. Consequently, the top layer may be subjected to thermal loads that are too high for the composite target material to handle without degradation. In such cases, detection systems and/or overtemperature controls must be incorporated into the heating system to detect changes in normal operating conditions and trigger safety devices.

Higher heating rates can be achieved in moving systems that result in higher production output. This higher output can be easily accomplished without complications on properly designed, installed and maintained infrared heating systems.

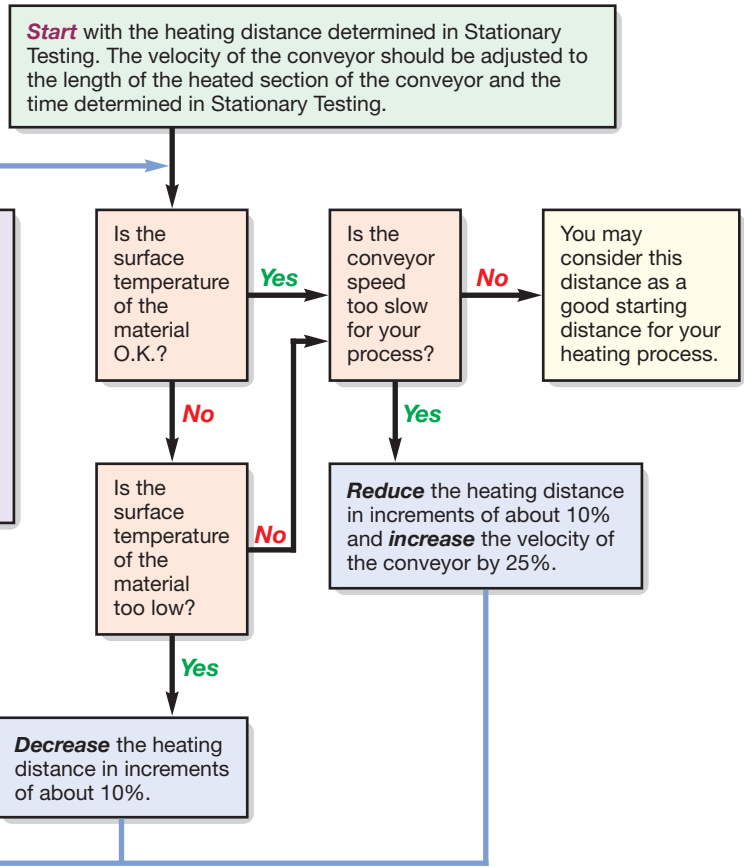

Material Thickness

The thickness of any given material is very important for most infrared heating applications. This is because many materials do not transmit the infrared energy past a few tenths of an inch; therefore, the heat is either reflected or absorbed.

The absorbed heat is conducted in all directions. In some paint processes, it is more convenient to select an infrared heater based on the absorption characteristic of the substrate and the transmit-

tance characteristic of the paint. By doing so, the radiant energy will be transmitted farther within the material and absorbed mostly in the substrate material. The temperature in the top layer of the substrate material will rise and heat the material above, heating from the inside out. Blistering is avoided or reduced to a minimum by employing this technique.

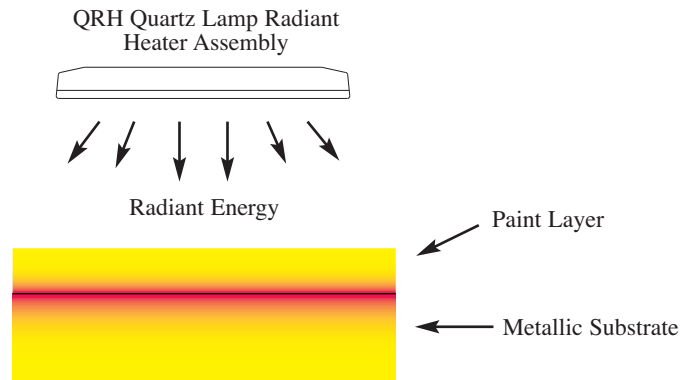
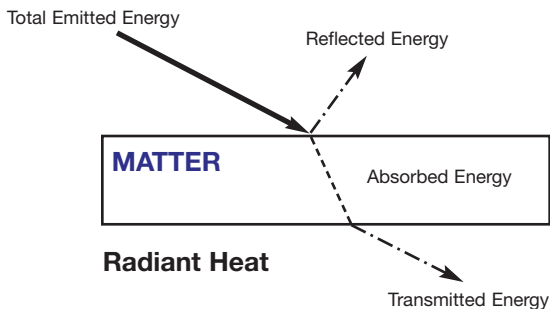

Ceramic Infrared E-Mitter Technical Data

An Example of Emissive Power

All E-Mitter ceramic infrared heaters emit infrared energy in various wavelengths depending on their surface temperature. The CRE00002 E-Mitter (bulb style, 250W, 120V, white) was tested as an example with the results shown on the right. The values associated with temperature, emitted wavelength distribution and percentages were obtained when the heater reached steady state conditions in room ambient. The value of the peak wavelength λ_{max} (3.7 microns) was calculated using Wien's displacement law for a blackbody from the peak temperature obtained in the tests. This calculation is valid since the spectral emissive power of our ceramic E-Mitter closely approximates the theoretical values in the Planck's formulation for infrared wavelength distribution.

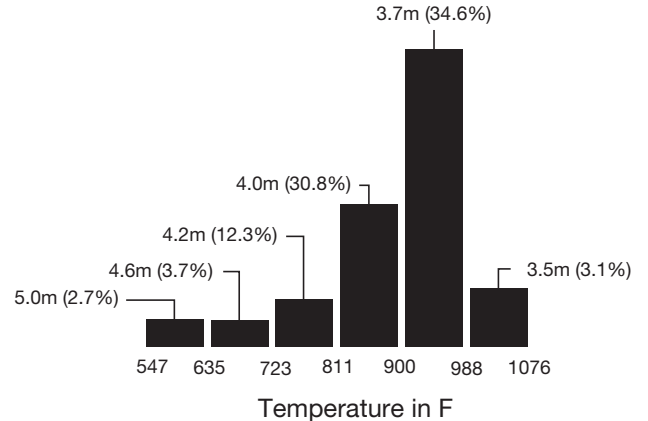

An Example of Emissive Power

Wien's Law is expressed by the following formula:

$$\lambda_{max} = 5215.6 \mu\text{m}/^{\circ}\text{F} \div (T + 460)$$

T = Temperature °F

λ_{max} = Peak Wavelength

Example:

What is the optimum peak E-Mitter surface temperature for heating a target material that has its best absorption in the infrared wavelength range of 4.0 to 3.4 microns (μm)?

$$\text{Average peak wavelength} = (4.0 + 3.4) \div 2 = 3.7 \mu\text{m}$$

Using Wien's law, we have:

$$3.7 \mu\text{m} = 5215.6 \div (^{\circ}\text{F} + 460) \text{ or } ^{\circ}\text{F} = (5215.6 \div 3.7) - 460 = 949.6^{\circ}\text{F}$$

This temperature is only a starting point and should be confirmed by testing and simulation of the exact conditions of the application. As you can see from the bar graph, this 950°F point coincides with the highest % of the radiated energy

from the CRE E-Mitter that was tested. Once the heater temperature has been established, the charts included in the various individual heater sections can be used to select the proper heater wattage starting point.

Conveyor Systems

Moving heating systems generally achieve higher output per hour than is possible with static systems. The radiant heater's setpoint temperature is set higher in conveyor systems than static systems due to the limited time the product is under the heaters. Tests should be carried out to determine the optimum conveyor speed, heating distance, and E-Mitter operating temperature.



In applications such as drying pulp paper, the higher power level required can potentially create a fire hazard if there are not safety mechanisms built into the system. If a malfunction of the conveyor system slows down or stops the conveyor completely, safety mechanisms should be triggered that would shut down power to the heaters to avoid burning the material being cured or dried.

Maximum Operating Temperature

Every heater has its maximum operating temperature printed on it. This temperature was measured with a thermocouple and with the heater facing down on a highly reflective material.

In many practical situations, however, this maximum temperature is rarely reached because most of the industrial materials absorb and transmit the heat while reflecting only a fraction of the infrared energy.

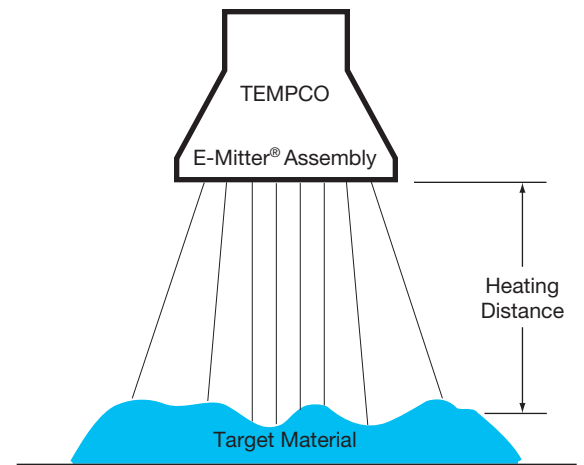

Ceramic E-Mitter Infrared Radiation Images

Infrared Radiation Images of Tempco's Ceramic E-Mitters (White, 240V, 400W)

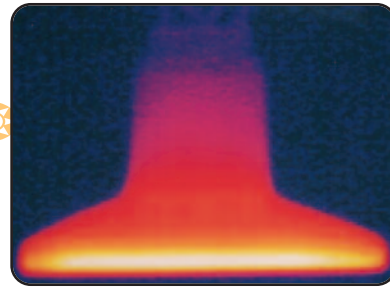
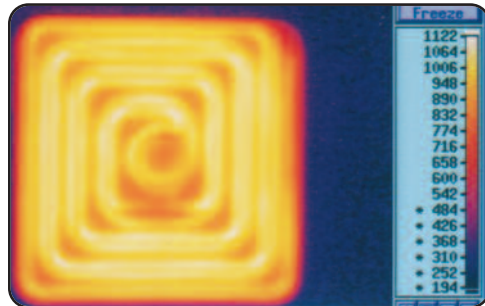
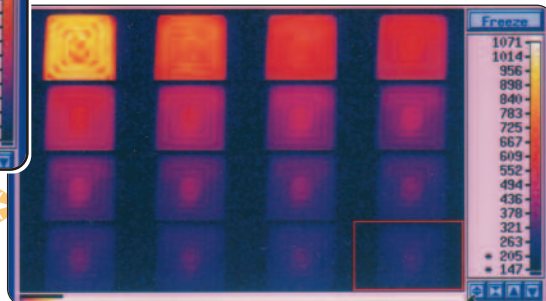
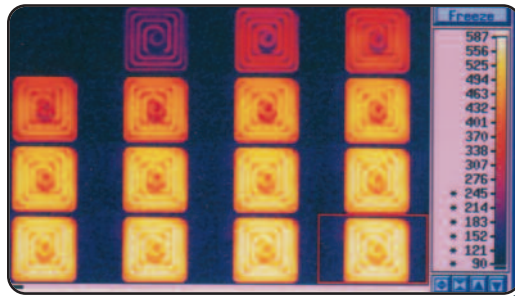

Image of Part Number CRD00002

Side View The lighter color (yellow) represents the hottest area(s), while the black (background) represents the ambient temperature. The air gap and the ceramic fiber insulation produce a dramatic temperature gradient between the heating elements (yellow region), and the supporting clamps (purple region).



Bottom View The temperature distribution in this face is particularly homogeneous, assuring a uniform radiant heat to a given application. The convective heat losses are more noticeable at the edges of the heater. Except in vacuum conditions, convective losses must always be considered in a heating application.



Infrared Images

These infrared images were recorded at 30-second intervals. The photo sequence on the left illustrates how the elements heat up over time. The photo sequence on the right illustrates how the elements cool down.



Note: The temperature scale (°F) corresponding to each color is on the right side of the images.

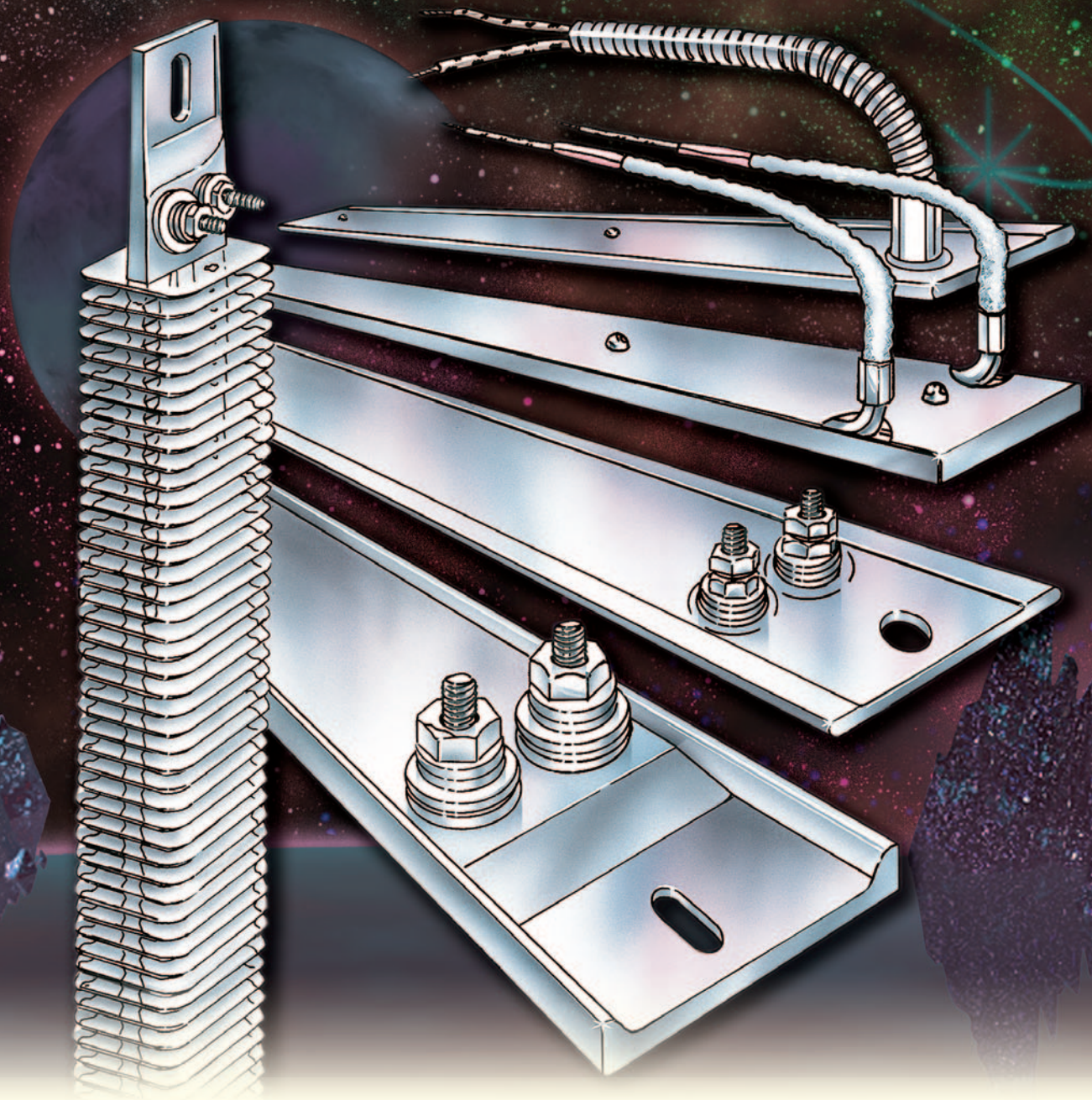

Table Of Contents

Pictorial Index	A-20
Channel Strip Heaters	8-2
ARC Channel Strip Heater Arrays	8-10
Finned Channel Strip Heaters	8-12
Maxistrip Heaters	8-16
Mica Insulated Strip Heaters	8-20



section

Strip Heaters

Ceramic Insulated

CHANNEL STRIP HEATERS

**A Reliable Heat Source
with Seamless
Stainless Steel Sheath
For Flat Surface
Mounting Installations,
Used in Hundreds
Of Industrial and Commercial
Heating Applications . . .**

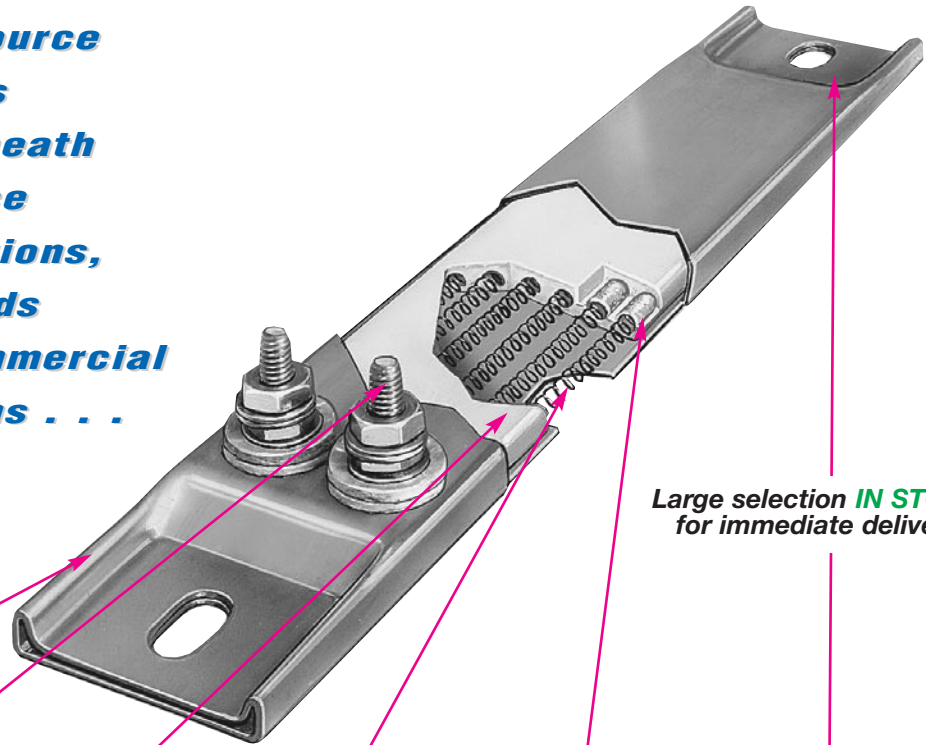

**Large selection IN STOCK
for immediate delivery**

A Type 304
Stainless
Steel

sheath provides the best combination of physical strength and resistance to high temperatures and chemical corrosion. Dependable at sheath temperatures of up to 1200°F (650°C).

B Stainless
Steel
10-32

threaded screws are standard and are securely fastened. Various termination configurations and options are available. See pages 8-4 through 8-7.

C Specially
selected
and de-

signed ceramic insulator houses the resistance wire coil, insulating it from the outer sheath.

D Helically
wound
resistance

wire coil made from nickel-chrome wire is evenly stretched and precisely strung through the ceramic insulator, providing uniform heat. Resistance wire is then mechanically connected to screw terminals or lead wires for a strong positive joint.

E A custom
mixture
of several

high purity magnesium oxide grain sizes, chosen to increase thermal conductivity and dielectric strength, are used to fill all remaining space inside and around the ceramic insulator. Voids are densely packed.

F Channel
strip
heaters

are available with or without mounting tabs. If without, the ends are silver soldered shut to prevent moisture and contaminants from entering the heater.

Typical Applications

- ➔ Ovens
- ➔ Hot Plates
- ➔ Dies
- ➔ Molds
- ➔ Drying
- ➔ Melting
- ➔ Baking
- ➔ Incubators
- ➔ Platens
- ➔ Food Warmers
- ➔ Welding Preheating
- ➔ Air Heating
- ➔ Sealing Bars
- ➔ Thermoforming
- ➔ Tank Heating



Note: Channel Strip Heaters are available with fins for air heating applications. See pages 8-12 through 8-15.

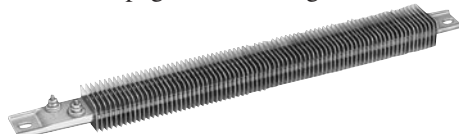

Agency Approvals



Channel Strip Heaters have been certified as Recognized Components by Underwriters Laboratories (File Number E65652) under CCN KSOT2/8 to meet UL standard 499 and Canadian Standard C22.2, No 72.

This file specifies the end use limitations and conditions of acceptability for the use of this type of heater. For additional information consult Tempco.

If you require UL, CSA, or other NRTL Agency Approvals, please specify when ordering.

Ceramic Insulated Channel Strip Heaters

Channel Strip Heaters have proven to be extremely efficient and dependable as a heat source for surface heating in hundreds of industrial and commercial applications.

For surface mounting installations, Channel Strip heaters must be securely clamped along their entire length to a smooth metal surface. When supported by mounting tabs, the terminal end should be secured firmly. Opposite end should be loose to allow for thermal expansion.

TEMPCO offers Channel Strip Heaters in three rectangular sizes

1" WIDE BY 5/16" THICK

Available with or without mounting tabs. When supplied with Type L lead wire termination, mounting tabs are not available.

1-1/2" WIDE BY 5/16" THICK

Available with or without mounting tabs. When supplied with Type L lead wire termination, mounting tabs are not available.

1-1/2" WIDE BY 3/8" THICK

Available with or without mounting tabs. When supplied with Type L lead wire termination, mounting tabs are not available. (3/8" thick heaters have radius corners)



Standard Specifications and Tolerances of Channel Strip Heaters
If tighter tolerances are required, consult Tempco.

PERFORMANCE RATINGS

- Maximum Sheath Temperature:** 1200°F (650°C)
- Nominal Watt Density:** 20 W/in² (3.1 W/cm²)
- Maximum Watt Density:** 45 W/in² (dependent on design parameters)

ELECTRICAL SPECIFICATIONS

- Maximum Voltage:** 480VAC (dependent on design parameters)
- Voltage Options:** Single-Phase, Three-Phase or Dual Voltage
- Maximum Recommended Voltage with Leads:** 480V
- Maximum Amperage:** Lead Wire Termination: 10 amp
Screw Terminations: 10-32UNF—25 amp
- Resistance Tolerance:** +10%, -5%
- Wattage Tolerance:** +5%, -10%

PHYSICAL SIZE CONSTRUCTION LIMITATIONS

- Width**
- 1" and 1-1/2" wide heaters +.000, -.010"
- Length**
- Up to 24" ±1/16"
- Over 24" ±1/8"
- Mounting Slot Size**
- Standard 5/16" × 1/2"
- Special Bushings 1/2" × 5/8"

Terminations

Screw Terminal Terminations

Type T1

- 10-32 Screw Terminals at each end
- Available on 1" and 1-1/2" wide heaters



No Mounting Tabs

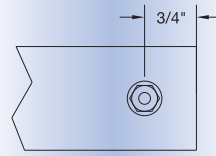

With Mounting Tabs

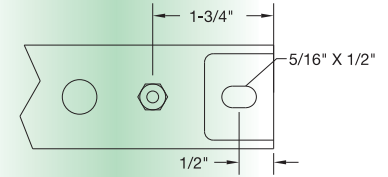

Type T2

- 10-32 Screw Terminals (Tandem) at one end
- Available on 1" and 1-1/2" wide heaters

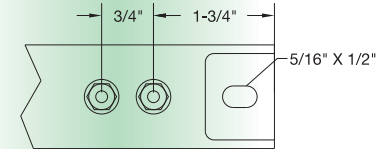
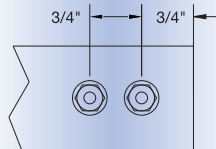

Type T3

- 10-32 Screw Terminals (Parallel) at one end
- Available on 1-1/2" wide heaters only

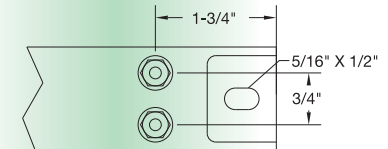
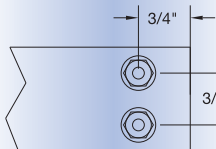
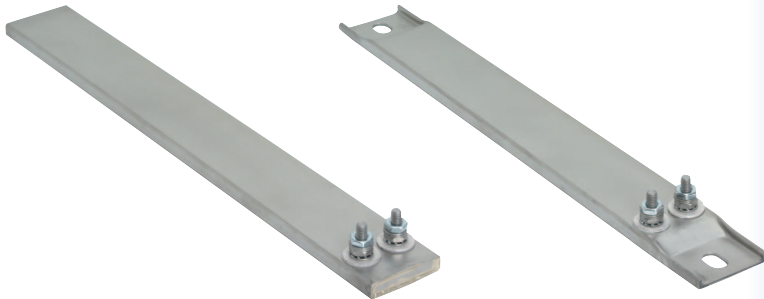

Type T4

- 10-32 Screw Terminals offset at one end
- Available on 1-1/2" wide heaters only

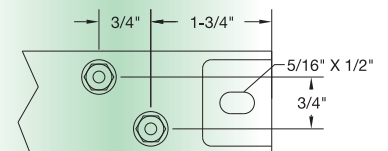
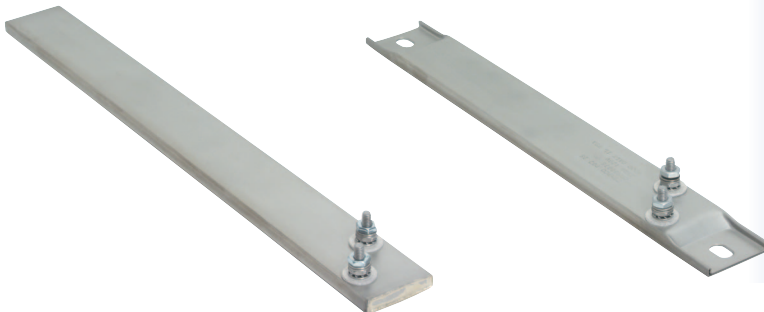

10-32 Screw Terminal Height

31/32"

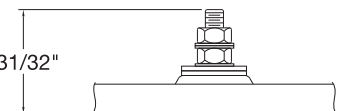

Lead Wire Terminations

Type L Flexible lead wires exit from end of heater. 10" long leads standard; if longer leads are required, specify. Recommended only for tight quarters or where flexibility of the lead wire is required. Not available on heaters with tabs.

Maximum Amps: 10 at 240VAC **Maximum Volts:** 480



Type L1 Flexible lead wires exit from top of heater. 10" long leads standard; if longer leads are required, specify.

Maximum Amps: 10 at 240VAC **Maximum Volts:** 480

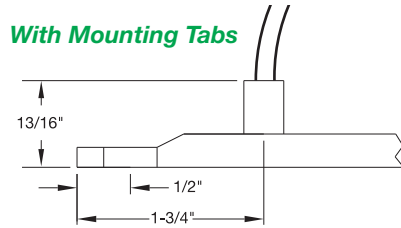
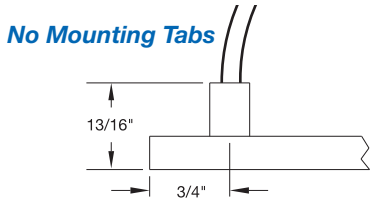
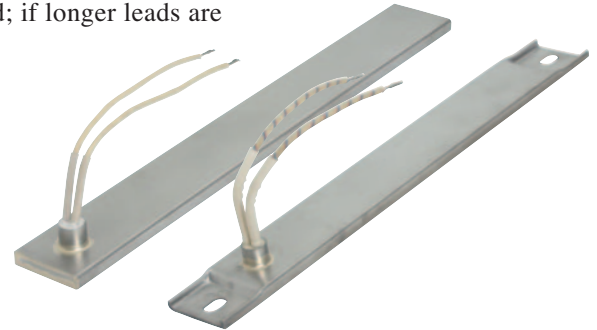

Type W1 Wire braid provides strength and protection to the lead wire insulation, offering sharp bending not possible with armor cable. 10" of wire braid over 12" long leads is standard; if longer leads or braid are required, specify.

Maximum Amps: 10 at 240VAC **Maximum Volts:** 480

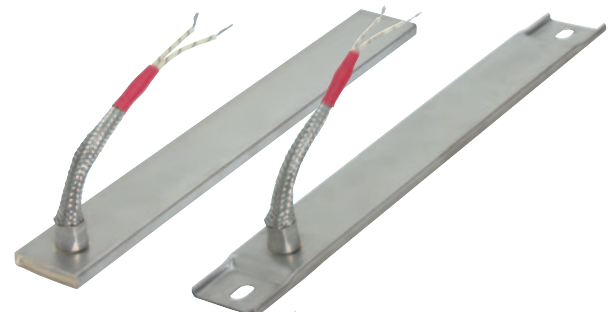
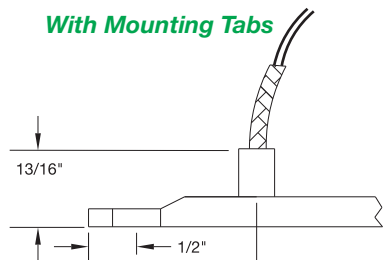
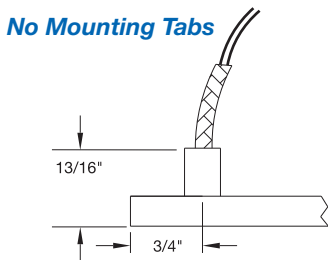

Type W2 Stainless steel braid over each lead wire offers sharp bending not possible with armor cable, as well as abrasion protection. 10" long leads standard; if longer leads are required, specify. Not available on heaters with tabs.

Maximum Amps: 10 at 240VAC **Maximum Volts:** 480



Type R1 Armor cable provides strength and prevents contamination from getting into the heater. 10" of armor over 12" long leads are standard; if longer leads or armor are required, please specify.

Maximum Amps: 10 at 240VAC **Maximum Volts:** 480

Type R1A: Galvanized cable **Type R1B:** Stainless steel cable

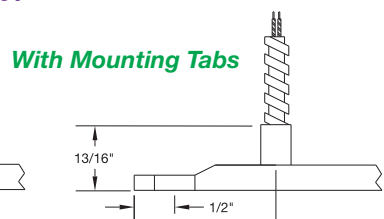
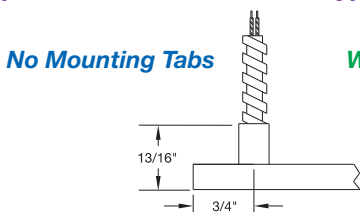

CONTINUED →

Terminations

Lead Wire Terminations

Continued from previous page...

Type R2 Right-angle armor cable prevents contamination from getting into the heater. 10" of armor over 12" long leads is standard; if longer leads or armor are required, please specify.

Maximum Amps: 10 at 240VAC **Maximum Volts:** 480

Type R2A Galvanized cable

Type R2B Stainless steel cable

Type R2C Elbow and leads only (no cable)

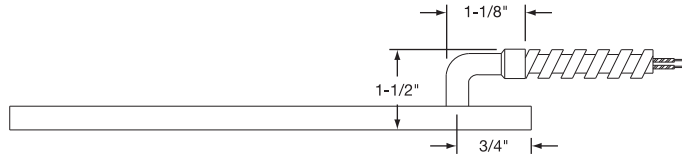
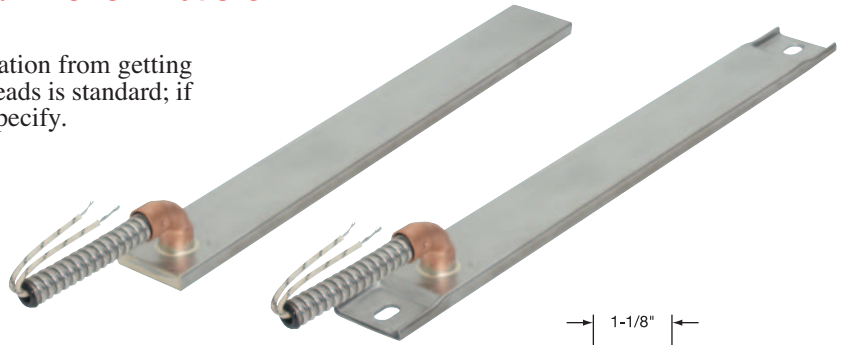

No Mounting Tabs

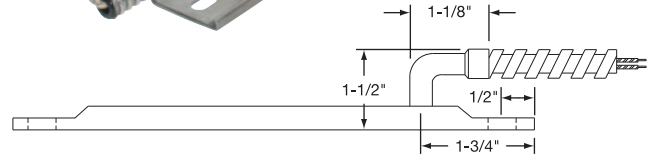

With Mounting Tabs

Terminal Protection

Type P High-Temperature Quick Disconnect Plug. If armor protected lead wires are required, specify armor and lead length. Available on 1-1/2" wide heaters only.

Maximum Amps: 10 at 240VAC **Maximum Volts:** 250

Type P1A Cup only (UT900)

Type P1B Cup and straight plug (H900)

Type P1C Cup and 90° plug (HW900)

Type P1D Cup, straight plug and galvanized cable

Type P1G Cup, 90° plug and galvanized cable

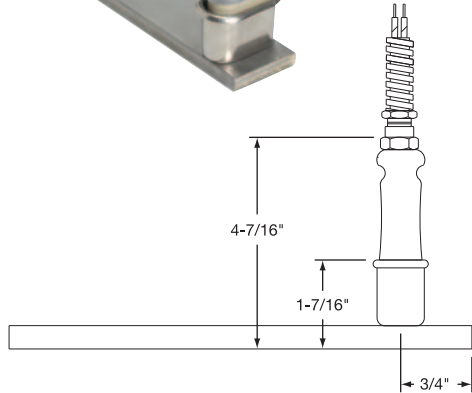
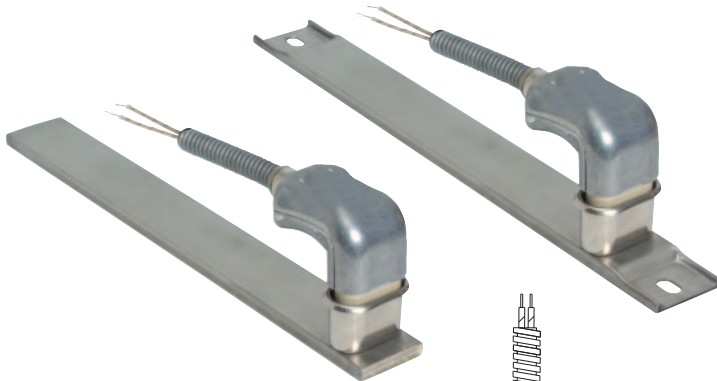

No Mounting Tabs (Type P1D Shown)

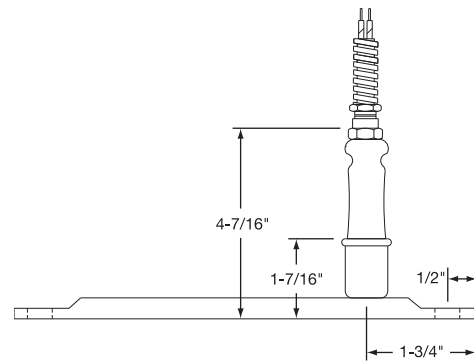

With Mounting Tabs (Type P1D Shown)

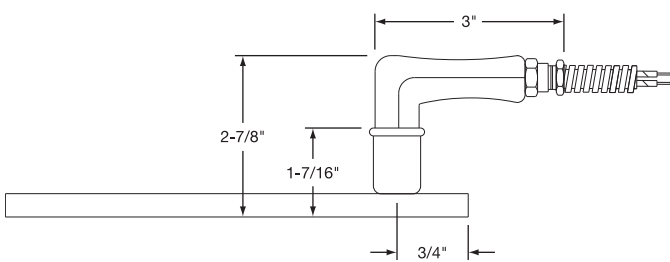

No Mounting Tabs (Type P1G Shown)

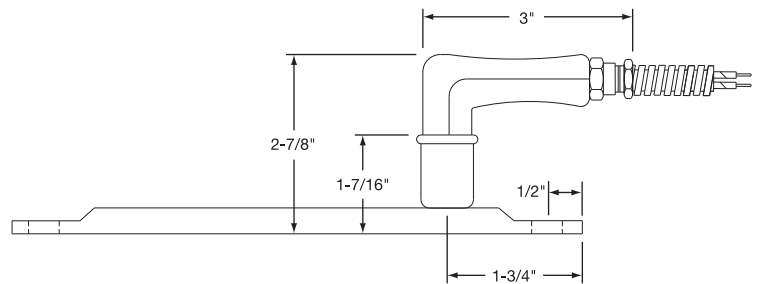

With Mounting Tabs (Type P1G Shown)

Exposed electrical wiring on Strip Heaters is a violation of electrical safety codes, including O.S.H.A.

Terminal Protection

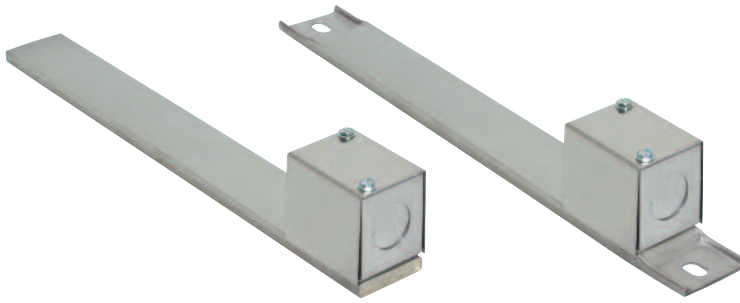

No Mounting Tabs

Type C Terminal box has a 1/2" trade size knockout (actual diameter 7/8"). Box provides excellent protection to exposed terminals. If armor-protected lead wires are required, specify armor and lead length. Available on 1" and 1-1/2" wide heaters.

- Type CA** No cable or braid
- Type CB** Galvanized cable
- Type CC** Stainless steel cable
- Type CD** Wire braid

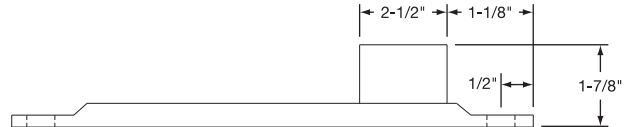

With Mounting Tabs

Type MP Specially designed box is welded to the Channel Strip Heater and potted with epoxy. The ends of the heater are also welded. Leads exit through a 1/2" NPT nut that can be located at the top or in the front of the box. Armor cable can be supplied with the male fitting, providing a completely sealed Channel Strip. Available on 1 1/2" wide heaters only.

10" long leads standard; if longer leads are required, specify.

Maximum Amps: 25 **Maximum Volts:** 480

- Type MPA** Box only
- Type MPB** Box with prewired galvanized cable
- Type MPC** Box with prewired stainless steel cable
- Type MPD** Box with prewired wire braid

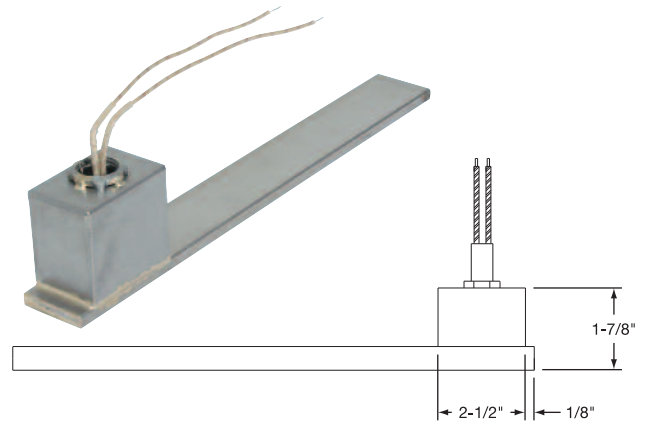

Ceramic Covers for Insulating Screw Terminals

Igloo™ Igloo Ceramic terminal covers consist of two individual ceramic parts. With a tight-fitting cap and a solid base, an Igloo cover will fully insulate any standard 10-32 terminal lug used for electrical wiring hookups. Igloo covers can be assembled on all Channel Strip heaters with Type T1 and Type T4 screw terminals.



Type C6

Double Port In-Line

Part Number: CER-101-104



Type C7

Double Port 90°

Part Number: CER-101-106



Type C8

Single Port

Part Number: CER-101-107

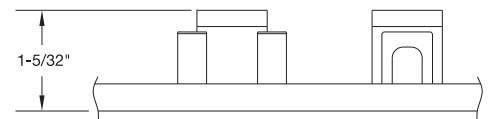

Ceramic Cap

Thread 10-32 **Part Number** CER-102-101

Three different types of Igloo bases are available for your wiring convenience. Double Port In-Line, Double Port 90° and Single Port. When ordering, specify the type of Igloo.

Strip Heaters



Standard Sizes and Ratings

Standard (Non-Stock) Sizes and Ratings

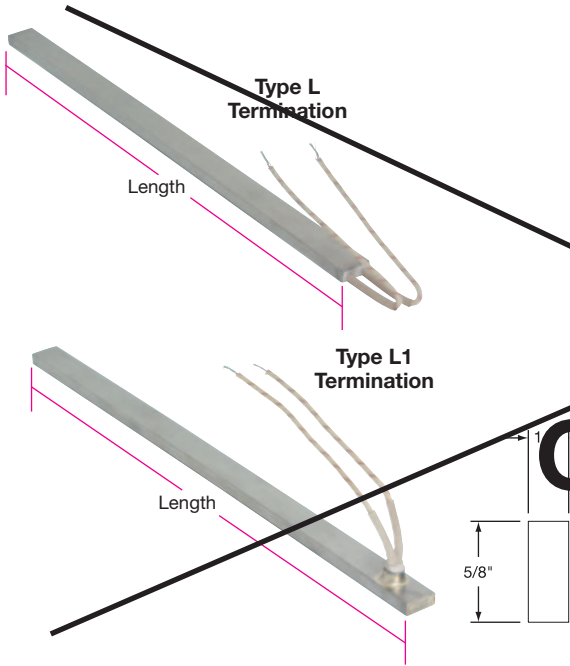

5/8" x 1/4" (15.88 x 6.35 mm) Channel Strip Heaters

Part numbers shown are for heaters with Type L Termination with 10" plain leads or Type L1 Termination with 10" plain leads.

- Additional available terminations: Type R2 and Type W1
- Mounting tabs are not available on this size.

Length in	mm	Wattage	Watt Density		Type	Part Number	
			W/in ²	W/cm ²		120V	240V
1½	38.1	50	29	4	L	CSH00001	—
2	50.8	50	19	3	L	CSH00002	—
3	76.2	150	34	5	L	—	CSH00003
3	76.2	150	34	5	L1	—	CSH00004
4	101.6	200	33	5	L	CSH00005	—
5	127.0	240	30	5	L	CSH00006	—
5	127.0	240	30	5	L1	CSH00007	CSH00008
6	152.4	250	22	3	L1	CSH00009	—
8	203.2	350	24	4	L	CSH00010	CSH00011
9	228.6	350	24	4	L1	CSH00012	—
12	304.8	500	25	4	L	—	CSH00013
13	330.2	500	23	4	L	CSH00014	—
14	355.6	550	23	4	L1	—	CSH00015
18	457.2	900	29	5	L	CSH00016	—
18	457.2	900	29	5	L1	CSH00017	CSH00018
20	508.0	1000	29	5	L1	CSH00019	CSH00020

Obsolete

1" x 5/16" (25.4 x 7.94 mm) Channel Strip Heaters Channel Strip Heaters with T2 Terminals and Mounting Tabs

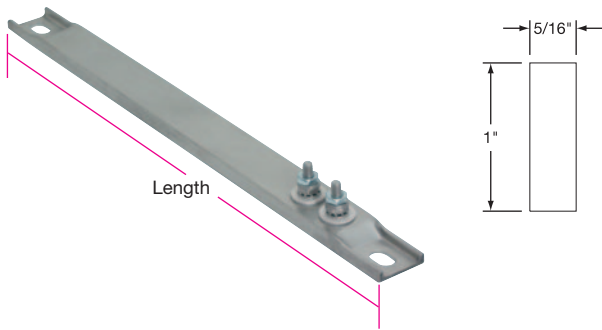

Length in	mm	Wattage	Watt Density		Part Number	
			W/in ²	W/cm ²	120V	240V
8	203.2	250	13	2	CSH00021	—
9½	241.3	300	13	2	CSH00022	—
11	279.4	350	13	2	CSH00023	—
12	304.8	400	13	2	CSH00024	CSH00025
14	355.6	450	13	2	CSH00026	CSH00027
15¼	387.4	500	13	2	CSH00028	CSH00029
17¼	454.0	600	13	2	CSH00030	CSH00031
19½	495.3	600	12	2	CSH00032	CSH00033
21	533.4	750	14	2	CSH00034	CSH00035
22½	571.5	750	13	2	CSH00036	CSH00037
23¾	603.3	800	13	2	CSH00038	CSH00039
25½	647.7	900	14	2	CSH00040	CSH00041
27½	698.5	900	13	2	CSH00042	CSH00043
28¾	730.3	1000	13	2	CSH00044	CSH00045
30½	774.7	1000	13	2	CSH00046	CSH00047
33½	850.9	1000	12	2	CSH00048	CSH00049
35¾	911.2	1000	11	2	CSH00050	CSH00051
38½	977.9	1250	13	2	CSH00052	CSH00053

Ordering Information

Catalog Heaters

Select a Channel Strip Heater from the Standard Sizes and Ratings lists on pages 8-8 through 8-11.

Channel Strip Heaters whose Part Numbers are in **RED** are available from Stock for immediate delivery.

Standard Non-Stock Part Numbers have a 3-week lead time.

Custom Engineered/Manufactured Heaters

An electric heater can be very application specific; for sizes and ratings not listed, **TEMPCO** will design and manufacture a Channel Strip Heater to meet your requirements. **Standard lead time is 3 weeks.**

Please Specify the following:

- Width & Thickness
- Length
- Wattage
- Voltage
- Termination (see pages 8-4 through 8-7)
- Lead Cable/Braid Length
- Special Features
- Quantity

⚠ WARNING: Cancer and Reproductive Harm - www.P65Warnings.ca.gov.

Standard (Non-Stock) and Stock Sizes and Ratings

1-1/2" x 5/16" (38.1 x 7.94 mm)
Channel Strip Heaters with T1 Terminals
and Mounting Tabs
Stock Items Are Shown In RED

Length in mm	Wattage	Watt Density		Part Number		
		W/in ²	W/cm ²	120V	240V	
6	152.4	150	21	3	CSH00316	CSH00583
8	203.2	150	14	2	CSH00218	CSH00219
8	203.2	250	23	4	CSH00220	CSH00221
9½	241.3	200	12	2	CSH00222	CSH00223
9½	241.3	300	18	3	CSH00224	CSH00225
10½	266.7	250	13	2	CSH00226	CSH00227
12	304.8	250	10	2	CSH00228	CSH00229
12	304.8	500	20	3	CSH00230	CSH00231
12	304.8	350	12	2	CSH00345	CSH00528
14	355.6	300	9	1	CSH00232	CSH00233
14	355.6	500	15	2	CSH00234	CSH00235
15¼	387.4	325	9	1	CSH00236	CSH00237
15¼	387.4	500	13	2	CSH00238	CSH00239
17⅞	454.2	375	8	1	CSH00240	CSH00241
17⅞	454.2	500	11	2	CSH00242	CSH00243
17⅞	454.2	750	16	2	CSH00244	CSH00245
17⅞	454.2	1000	21	3	CSH00246	CSH00247
19½	495.3	500	10	1	CSH00248	CSH00249
19½	495.3	750	14	2	CSH00250	CSH00251
19½	495.3	1000	19	3	CSH00252	CSH00253
19½	495.3	1200	23	4	CSH00326	CSH00330
21	533.4	500	9	1	CSH00254	CSH00255
23¾	603.3	250	4	1	CSH00256	CSH00257
23¾	603.3	500	7	1	CSH00258	CSH00259
23¾	603.3	750	11	2	CSH00260	CSH00261
23¾	603.3	1000	15	2	CSH00262	CSH00263
23¾	603.3	1500	22	3	CSH00264	CSH00265
25½	647.7	750	10	2	CSH00266	CSH00267

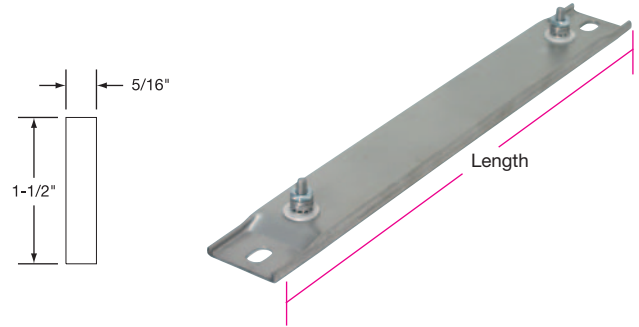

Stock Items Are Shown In RED

Length in mm	Wattage	Watt Density		Part Number		
		W/in ²	W/cm ²	120V	240V	
25½	647.7	1000	13	2	CSH00268	CSH00269
26¾	679.5	700	9	1	CSH00270	CSH00271
26¾	679.5	750	10	1	CSH00272	CSH00273
29¼	742.0	750	8	1	CSH00347	CSH00348
29⅞	758.8	750	8	1	CSH00274	CSH00275
30½	774.7	750	8	1	CSH00276	CSH00277
33½	850.9	750	7	1	CSH00278	CSH00279
33½	850.9	1000	10	2	CSH00280	CSH00281
34⅞	879.5	1000	9	1	CSH00282	CSH00283
35⅞	911.4	1000	9	1	CSH00284	CSH00285
37¼	946.2	1500	13	2	CSH00286	CSH00287
38½	977.9	1000	8	1	CSH00288	CSH00289
42½	1079.5	1250	9	1	CSH00290	CSH00291
42½	1079.5	1500	11	2	CSH00292	CSH00293

1-1/2" x 5/16" (38.1 x 7.94 mm)
Channel Strip Heaters with T2 Terminals
and Mounting Tabs
Stock Items Are Shown In RED

Length in mm	Wattage	Watt Density		Part Number		
		W/in ²	W/cm ²	120V	240V	
6	152.4	150	21	3	CSH00317	CSH00320
8	203.2	150	13	2	CSH00189	CSH00190
8	203.2	250	21	3	CSH00342	CSH00343
8	203.2	500	42	7	CSH00322	CSH00325
10½	266.7	250	12	2	CSH00191	CSH00192
12	304.8	350	13	2	CSH00193	CSH00194
14	355.6	500	15	2	CSH00195	CSH00196
17⅞	454.2	750	16	2	CSH00197	CSH00198
19½	495.3	1200	23	4	CSH00327	CSH00331
23¾	603.3	750	11	2	CSH00199	CSH00200
25½	647.7	500	7	1	—	CSH00201
29¼	743.0	750	8	1	CSH00202	CSH00203
33½	850.9	750	7	1	CSH00204	—
34⅞	879.5	1000	9	1	CSH00205	CSH00206
35⅞	911.2	1000	9	1	CSH00207	CSH00208
37¼	946.2	1500	13	2	CSH00209	CSH00210

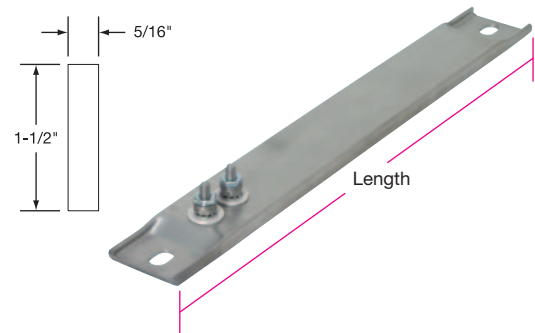

Length in mm	Wattage	Watt Density		Part Number		
		W/in ²	W/cm ²	120V	240V	
38½	977.9	800	7	1	CSH00211	—
53⅞	1368.6	1500	8	1	—	CSH00212
53⅞	1368.6	2500	14	2	—	CSH00213
63⅞	1622.6	1800	8	1	—	CSH00214
63⅞	1622.6	3000	14	2	—	CSH00215
71⅞	1825.8	2000	8	1	—	CSH00216
71⅞	1825.8	3000	12	2	—	CSH00217

Strip Heaters



Standard Sizes and Ratings

Standard (Non-Stock) and Stock Sizes and Ratings

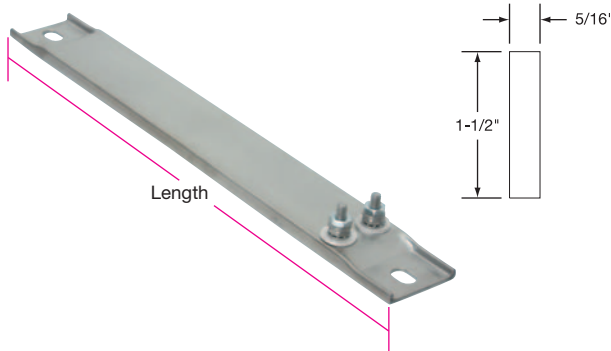

1-1/2" x 5/16" (38.1 x 7.94 mm)
Channel Strip Heaters with T3 Terminals
and Mounting Tabs

Stock Items Are Shown In **RED**

Stock Items Are Shown In **RED**

Length in mm	Wattage	Watt Density		Part Number	
		W/in ²	W/cm ²	120V	240V
5¼ 133.4	125	20	3	CSH00336	CSH00337
5½ 139.7	125	23	4	CSH00159	CSH00160
5½ 139.7	250	34	5	CSH00161	CSH00162
5¾ 146.1	300	47	7	CSH00163	CSH00164
6 152.4	150	17	3	CSH00165	CSH00166
6 152.4	300	41	6	CSH00167	CSH00168
8 203.2	150	10	2	CSH00169	CSH00170
8 203.2	250	17	3	CSH00344	CSH00171
8 203.2	500	34	5	CSH00323	CSH00324
10½ 266.7	250	11	2	CSH00172	CSH00173
10½ 266.7	400	17	3	CSH01618	CSH01433
12 304.8	250	9	1	CSH01600	CSH01601
12 304.8	350	12	2	CSH00346	CSH00174
14 355.6	300	8	1	CSH01602	CSH01603
14 355.6	500	14	2	CSH00175	CSH00176
15¼ 387.4	325	8	1	CSH01604	CSH01605
17⅞ 454.2	500	11	2	CSH01606	CSH01607
17⅞ 454.2	750	15	2	CSH00177	CSH00178
17⅞ 454.2	1000	21	3	—	CSH01257
19½ 495.3	350	7	1	CSH01608	CSH01609

Length in mm	Wattage	Watt Density		Part Number	
		W/in ²	W/cm ²	120V	240V
19½ 495.3	1200	21	3	CSH00328	CSH00332
21 533.4	500	8	1	CSH01610	CSH01611
21 533.4	750	13	2	CSH01620	CSH01621
23¾ 603.3	750	10	2	CSH00179	CSH00180
23¾ 603.3	1000	15	2	CSH01624	CSH01625
25½ 647.7	500	7	1	CSH01613	CSH01614
26¾ 679.5	700	9	1	CSH01615	CSH01616
26¾ 679.5	1000	13	2	CSH01655	CSH01626
29¼ 743.0	750	8	1	CSH00181	CSH00182
30½ 774.7	750	8	1	CSH01627	CSH01628
30½ 774.7	1250	13	2	—	CSH01629
33½ 850.9	950	9	1	CSH01630	CSH01631
34⅞ 879.5	1000	9	1	CSH00183	CSH00184
35⅞ 911.4	1000	9	1	CSH00185	CSH00186
35⅞ 911.4	1500	13	2	—	CSH00462
37¼ 946.2	1500	12	2	CSH00187	CSH00188
42½ 1079.5	1500	11	2	—	CSH01632
45½ 1155.7	1250	8	1	—	CSH01617
47⅞ 1216.0	2250	14	2	—	CSH01230

Ordering Information

See page 8-8

Type ARC Channel Strip Radiant Heater Arrays



Tempco can design and manufacture a custom channel strip heater array for applications requiring infrared heat. Call for details.

Other type of infrared heaters can be found in [Section 7](#).



Standard (Non-Stock) Sizes and Ratings

1-1/2" x 5/16" (38.1 x 7.94 mm) Channel Strip Heaters with T4 Terminals and Mounting Tabs

Stock Items Are Shown In RED

Length in mm	Wattage	Watt Density		Part Number		
		W/in ²	W/cm ²	120V	240V	
5¼	133.4	125	34	5	CSH00338	CSH00339
5¾	146.1	300	55	8	CSH01596	CSH01595
6	152.4	150	24	4	CSH00318	CSH00321
7½	190.5	150	15	2	CSH00054	CSH00055
7½	190.5	200	20	3	CSH00056	CSH00057
8	203.2	150	13	2	CSH00058	CSH00059
8	203.2	175	15	2	CSH00060	CSH00061
8	203.2	250	21	3	CSH00062	CSH00063
8	203.2	400	31	5	CSH00064	CSH00065
8	203.2	500	42	7	CSH00066	CSH00067
10½	266.7	250	12	2	CSH00068	CSH00069
10½	266.7	350	17	3	CSH00070	CSH00071
10½	266.7	400	19	3	CSH00072	CSH00073
12	304.8	250	10	1	CSH00074	CSH00075
12	304.8	350	13	2	CSH00076	CSH00077
12	304.8	500	19	3	CSH00078	CSH00079
14	355.6	300	9	1	CSH00080	CSH00081
14	355.6	500	15	2	CSH00082	CSH00083
15¼	387.4	325	9	1	CSH00084	CSH00085
15¼	387.4	500	13	2	CSH00086	CSH00087
17⅞	454.2	350	7	1	CSH00088	CSH00089
17⅞	454.2	375	8	1	CSH00090	CSH00091
17⅞	454.2	500	11	2	CSH00092	CSH00093
17⅞	454.2	750	16	2	CSH00094	CSH00095
17⅞	454.2	1000	23	3	CSH00096	CSH00097
19½	495.3	350	7	1	CSH00098	CSH00099
19½	495.3	500	9	1	CSH00100	CSH00101
19½	495.3	750	14	2	CSH00102	CSH00103
19½	495.3	1000	19	3	CSH00104	CSH00105
19½	495.3	1200	23	4	CSH00329	CSH00333
21	533.4	500	8	1	CSH00106	CSH00107
21	533.4	750	13	2	CSH00108	CSH00109
23¾	603.3	500	7	1	CSH00110	CSH00111
23¾	603.3	750	11	2	CSH00112	CSH00113

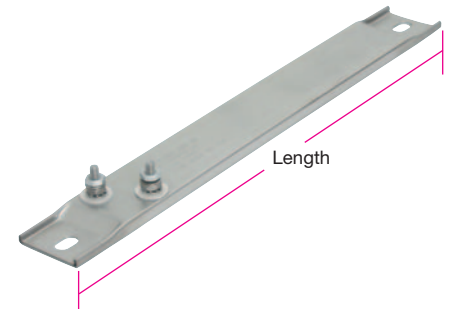
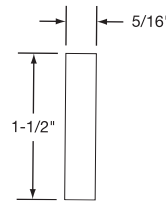

Stock Items Are Shown In RED

Length in mm	Wattage	Watt Density		Part Number		
		W/in ²	W/cm ²	120V	240V	
23¾	603.3	1000	15	2	CSH00114	CSH00115
23¾	603.3	1500	22	3	CSH00116	CSH00117
25½	647.7	500	7	1	CSH00118	CSH00119
25½	647.7	750	10	2	CSH00120	CSH00121
25½	647.7	1000	13	2	CSH00122	CSH00123
26¼	679.5	700	9	1	CSH00124	CSH00125
26¼	679.5	750	9	1	CSH00126	CSH00127
26¼	679.5	1000	13	2	CSH00128	CSH00129
29¼	743.0	750	8	1	CSH00130	CSH00131
30½	774.7	750	8	1	CSH00132	CSH00133
30½	774.7	1000	11	2	CSH00134	CSH00135
30½	774.7	1250	13	2	—	CSH00136
33½	850.9	750	7	1	CSH00137	CSH00138
34%	879.5	1000	9	1	CSH00139	CSH00140
35%	911.4	1000	9	1	CSH00141	CSH00142
35%	911.4	1500	13	2	CSH00143	CSH00144
37¼	946.2	1500	13	2	CSH00145	CSH00146
38½	977.9	800	7	1	CSH00147	CSH00148
38½	977.9	1000	8	1	CSH00149	CSH00150
38½	977.9	1500	12	2	CSH00151	CSH00152
42½	1079.5	1250	9	1	CSH00153	CSH00154
42½	1079.5	1500	11	2	CSH00155	CSH00156
47%	1216.2	1350	9	1	—	CSH00157
47%	1216.2	2250	14	2	—	CSH00158

1-1/2" x 3/8" (38.1 x 9.53 mm) Channel Strip Heaters with T4 Terminals and Mounting Tabs

Length in mm	Wattage	Watt Density		Part Number		
		W/in ²	W/cm ²	120V	240V	
7½	190.5	200	19	3	—	CSH00294
9	228.6	500	31	5	—	CSH00295
10½	266.7	250	12	2	CSH00296	—
10½	266.7	400	19	3	CSH00297	—
12	304.8	500	18	3	—	CSH00298
15¼	387.4	500	13	2	—	CSH00299
17	431.8	1000	22	3	—	CSH00300
17⅞	454.0	350	7	1	—	CSH00301
17⅞	454.0	500	10	2	—	CSH00302
18	457.2	1000	20	3	—	CSH00303
18½	469.9	500	10	2	—	CSH00304
22½	571.5	1000	15	2	—	CSH00305
24	609.6	1000	14	2	—	CSH00306
25½	647.7	1000	13	2	—	CSH00307
26	660.4	1600	20	3	—	CSH00308
26½	673.1	1500	18	3	—	CSH00309

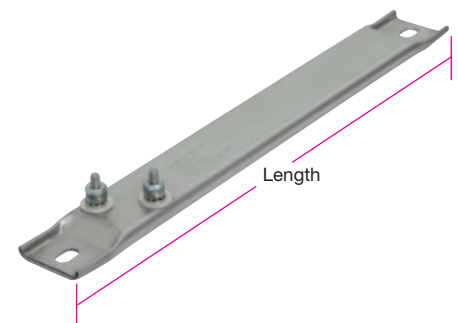
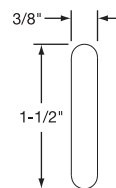

Length in mm	Wattage	Watt Density		Part Number		
		W/in ²	W/cm ²	120V	240V	
30½	774.7	750	8	1	—	CSH00310
31½	800.1	800	8	1	—	CSH00311
35%	911.2	1000	9	1	—	CSH00312
36	914.4	1000	9	1	—	CSH00313
50	1270.0	1000	6	1	—	CSH00314
62	1574.8	1500	7	1	—	CSH00315

FINNED STRIP Heaters

Ceramic Insulated Finned Strip Heaters

TEMPCO Finned Strip Heaters are extremely efficient and dependable as a heat source for hundreds of industrial and commercial applications. They are used for both forced (mounted in a duct) and natural convection air heating (mounted at the bottom of cabinet type ovens).

The Finned Strip Heater's basic design consists of a helically wound resistance coil placed in a specially designed ceramic insulator. The resistance coil is mechanically connected to the screw terminal for positive connection. Stainless steel rectangular tubing is used to house the heater assembly. All remaining voids are filled with high purity magnesium oxide to increase thermal conductivity and dielectric strength.

Typical Applications

- ➔ Duct Heating
- ➔ Space Heaters
- ➔ Drying Ovens
- ➔ Food Warmers
- ➔ Dehumidifier
- ➔ Shrinking Tunnels
- ➔ Air Heating
- ➔ Heat Curing

Nickel-plated steel fins (Stainless Steel optional) are mounted to the rectangular tubing. The fins have been specially designed to provide maximum surface contact for good heat dissipation into the finned cross sections, thus resulting in rapid heat transfer to the air.

TEMPCO Finned Strip Heaters are manufactured in a full line of standard sizes, electrical ratings and terminations, or can be made to your specifications.

Design Features

- * Rugged, Durable Construction
- * Stainless Steel Sheath
- * Nickel-Plated Steel Fins (Stainless Steel Optional)
- * Various Terminations
- * Trouble-Free Installation
- * Various Sizes in Stock

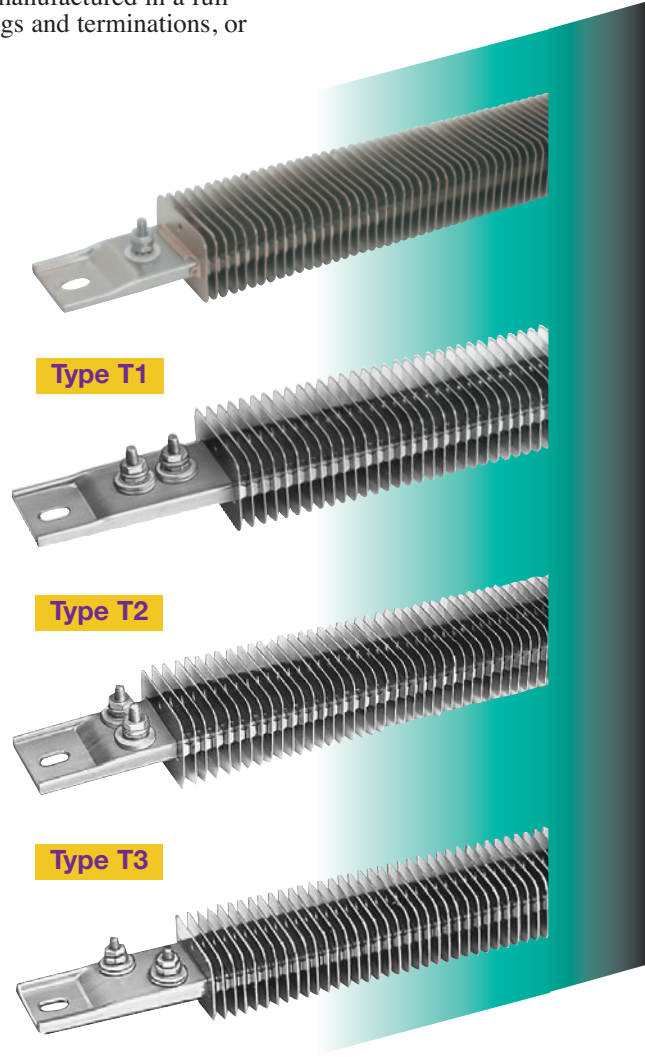
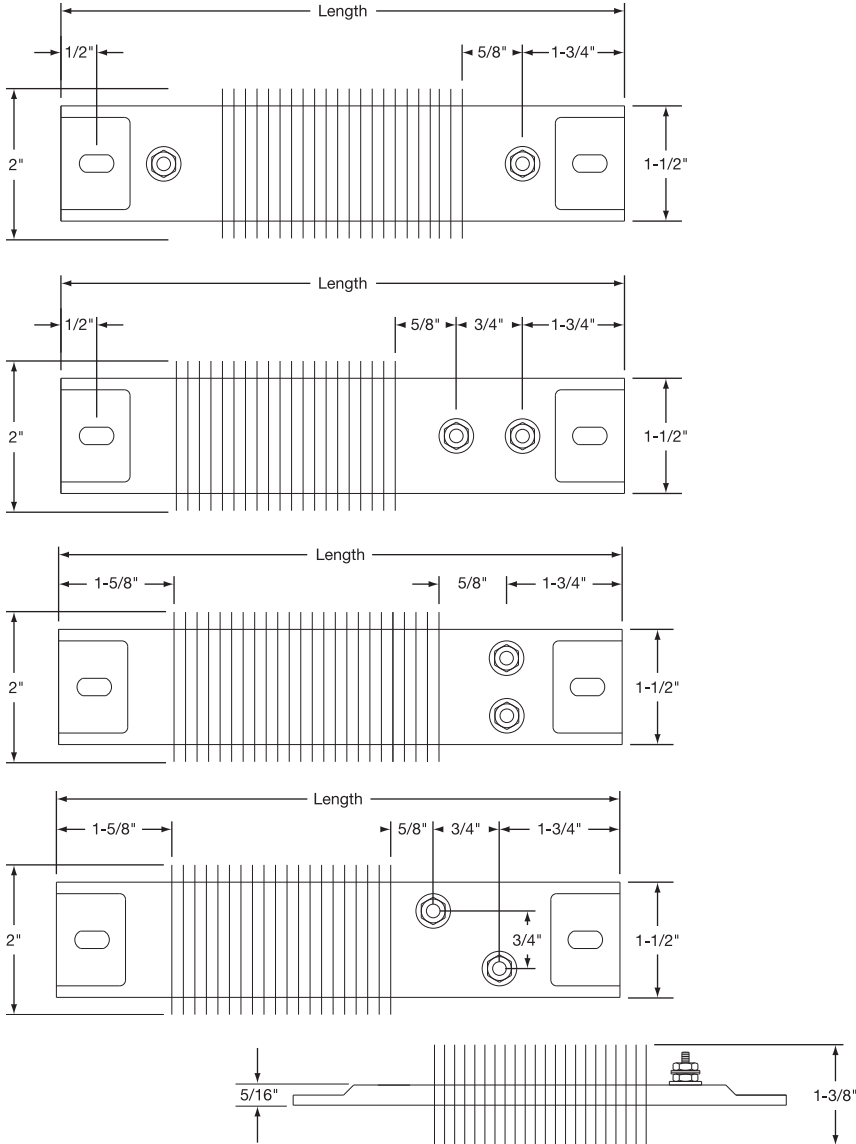

Fin Height

Large selection **IN STOCK** for immediate delivery

Specifications & Tolerances

Standard Specifications and Tolerances of Finned Strip Heaters If tighter tolerances are required, consult Tempco.

PERFORMANCE RATINGS

Maximum Sheath Temperature: 1200°F (650°C)

Maximum Watt Density:

Still Air	Max. W/in ²	Max. W/cm ²
Up to 300°F (149°C)	20	3.1
300° to 600°F (149° to 316°C)	16	2.5
600° to 800°F (316° to 427°C)	10	1.6
Moving Air	Max. W/in ²	Max. W/cm ²
At 600 ft./min., up to 200°F	40	6.2
(3 m/sec., up to 93°C)		
At 600 ft./min., up to 400°F	30	4.7
(3 m/sec., up to 204°C)		
At 600 ft./min., up to 600°F	20	3.1
(3 m/sec., up to 316°C)		

ELECTRICAL SPECIFICATIONS

Maximum Voltage: 480VAC (when applicable)

Maximum Amperage: 25 amps

Resistance Tolerance: +10%, -5%

Wattage Tolerance: +5%, -10%

MATERIAL SPECIFICATIONS & PHYSICAL SIZES

Sheath: 304 Stainless Steel

Fins: Nickel Plated Steel (Stainless Steel Optional)

Screw Terminals: Stainless Steel 10-32 UNF Threads

Width Including Fins: 2"

Height Including Fins: 1-3/8"

Length Tolerance: Up to 24" ± 1/16", over 24" ± 1/8"

Mounting Slot Size: Standard 5/16" × 1/2"

Slot Size For Secondary Insulating Bushing:
1/2" × 5/8" for 300 Volts and above



Finned Channel Strip Heaters have been certified as Recognized Components by Underwriters Laboratories (File Number E65652) under CCN KSOT2/8 to meet UL standard 499 and Canadian Standard C22.2 No. 72.

This file specifies the end use limitations and conditions of acceptability for the use of this type of heater. For additional information consult Tempco.

If you require UL/CSA Agency Approval, please specify when ordering.

Secondary Insulating Bushings

Used to mount finned strip heaters in air heating applications. Also can be used when it is necessary to electrically isolate the heater from ground. When Insulating Bushings are required, a 1/2" × 5/8" slot is substituted for the standard slot size (5/16" × 1/2").



When using secondary insulating bushings, the heater must be guarded to avoid any accidental contact. The guard must be electrically isolated from the heater and must be properly grounded.

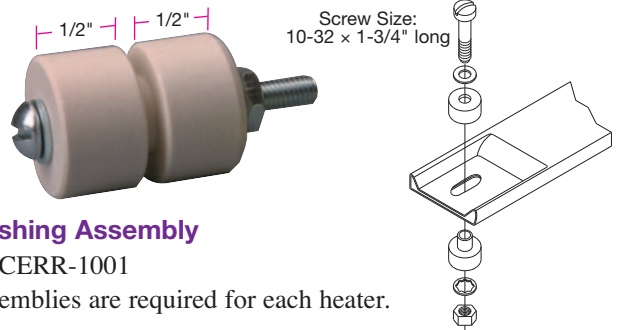

Insulating Bushing Assembly

Part Number: CERR-1001

NOTE: Two assemblies are required for each heater.

Ceramic Covers for Insulating Screw Terminals

Igloo™ Ceramic Covers

Igloo Ceramic terminal covers consist of two individual ceramic parts. With a tight-fitting cap and a solid base, an Igloo cover will fully insulate any standard 10-32 terminal lug used for electrical wiring hookups.

Igloo covers can be assembled on all Channel Strip and Finned Strip heaters with Type T1 and Type T4 screw terminals. Channel Strip heaters with screw terminals that have a minimum center to center distance of 7/8" can also be assembled with Igloo covers.

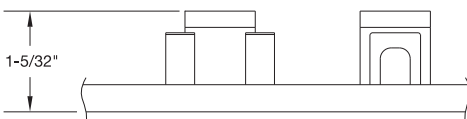

Type C6
Double Port In-Line
Part Number: CER-101-104



Type C7
Double Port 90°
Part Number: CER-101-106



Type C8
Single Port
Part Number: CER-101-107

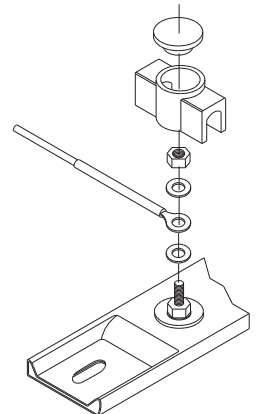

Ceramic Cap
Thread 10-32
Part Number CER-102-101

Strip Heaters



Standard Sizings and Ratings

Standard (Non-Stock) and Stock Sizes and Ratings



Stock Items Are Shown In **RED**

Length in	mm	Wattage	Watt Density		Part Number	
			W/in ²	W/cm ²	120V	240V
10½	266.7	350	18	3	CSF00519	CSF00520
10½	266.7	500	34	5	CSF00121	CSF00122
10½	266.7	725	45	7	CSF00123	CSF00124
12	304.8	900	40	6	CSF00131	CSF00132
14	355.6	750	28	4	CSF00232	CSF00249
14	355.6	1100	37	6	CSF00135	CSF00136
15¼	387.4	1250	37	6	CSF00139	CSF00140
17⅞	454.0	750	18	3	CSF00506	CSF00524

Finned Strip Heaters with T1 Terminals

Stock Items Are Shown In **RED**

Length in	mm	Wattage	Watt Density		Part Number	
			W/in ²	W/cm ²	120V	240V
17⅞	454.0	1000	25	4	CSF00540	CSF00525
17⅞	454.0	1550	38	6	CSF00144	CSF00145
19½	495.3	1000	21	3	—	CSF00526
19½	495.3	1700	36	6	—	CSF00150
21	533.4	1900	36	6	CSF00154	CSF00155
23¼	603.3	1000	16	3	—	CSF00527
23¼	603.3	1450	24	4	CSF00529	—
23¼	603.3	2200	36	6	—	CSF00159
25½	647.7	1500	23	3	CSF00530	CSF00531
25½	647.7	2400	35	5	—	CSF00165
26¾	679.5	2500	34	5	—	CSF00167
30½	774.7	1800	21	3	—	CSF00532
30½	774.7	2800	29	5	—	CSF00176
33½	850.9	2100	21	3	—	CSF00533
33½	850.9	3150	32	5	—	CSF00178
35⅞	911.2	3450	33	5	—	CSF00181
42½	1079.5	4150	31	5	—	CSF00217
48	1219.2	2250	15	2	—	CSF00534

Finned Strip Heaters with T2 Terminals

Stock Items Are Shown In **RED**

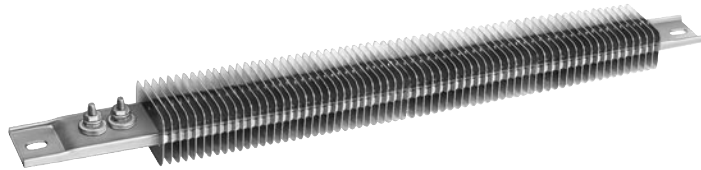

Length in	mm	Wattage	Watt Density		Part Number	
			W/in ²	W/cm ²	120V	240V
10½	266.7	725	36	6	CSF00127	CSF00128
12	304.8	900	36	6	CSF00133	CSF00134
14	355.6	1100	32	5	CSF00137	CSF00138
15¼	387.4	1250	34	5	CSF00141	CSF00142
17⅞	454.0	1550	33	5	CSF00146	CSF00147
19½	495.3	1700	30	5	CSF00151	CSF00152
25½	647.7	2400	33	5	—	CSF00166
30½	774.7	2800	31	5	—	CSF00177

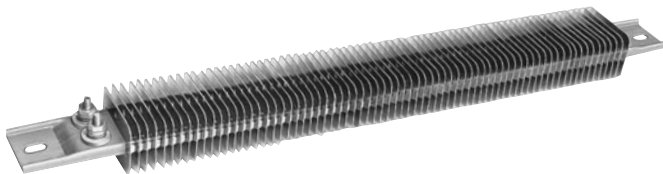

Stock Items Are Shown In **RED**

Length in	mm	Wattage	Watt Density		Part Number	
			W/in ²	W/cm ²	120V	240V
10½	266.7	350	16	3	CSF00500	CSF00501
10½	266.7	500	21	3	CSF00001	CSF00002
10½	266.7	725	31	5	CSF00003	CSF00004
12	304.8	500	17	3	CSF00005	—
12	304.8	650	23	3	—	CSF00007
12	304.8	900	31	5	CSF00008	CSF00009
14	355.6	750	21	3	CSF00010	CSF00011
14	355.6	1100	31	5	CSF00012	CSF00013
15¼	387.4	1250	31	5	CSF00014	CSF00015
17⅞	454.0	750	16	3	CSF00505	CSF00543
17⅞	454.0	1000	21	3	CSF00539	CSF00507
17⅞	454.0	1550	31	5	CSF00016	CSF00017

Finned Strip Heaters with T3 Terminals

Stock Items Are Shown In **RED**

Length in	mm	Wattage	Watt Density		Part Number	
			W/in ²	W/cm ²	120V	240V
19½	495.3	1000	19	3	—	CSF00508
19½	495.3	1700	31	5	CSF00018	CSF00019
21	533.4	1900	31	5	CSF00024	CSF00025
23¼	603.3	1000	15	2	—	CSF00509
23¼	603.3	1450	21	3	CSF00511	—
23¼	603.3	2200	32	5	—	CSF00026
25½	647.7	1500	21	3	CSF00513	CSF00514
25½	647.7	2400	32	5	—	CSF00027
26¾	679.5	2500	30	5	—	CSF00028
30½	774.7	1800	19	3	—	CSF00515
30½	774.7	2800	30	5	—	CSF00031
33½	850.9	2100	20	3	—	CSF00517
33½	850.9	3150	30	5	—	CSF00033
35⅞	911.2	3450	31	5	—	CSF00034
42½	1079.5	4150	31	5	—	CSF00036
48	1219.2	2250	14	2	—	CSF00037

Standard (Non-Stock) and Stock Sizes and Ratings

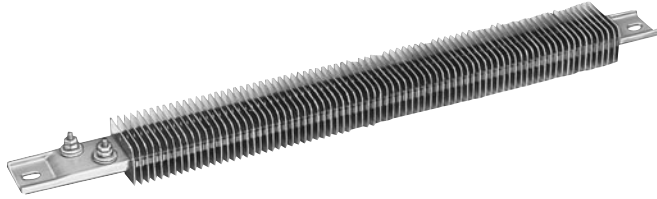

Stock Items Are Shown In **RED**

Length in mm	Wattage	Watt Density		Part Number	
		W/in ²	W/cm ²	120V	240V
8½ 215.9	250	18	3	CSF00252	CSF00039
10½ 266.7	350	17	3		CSF00130
10½ 266.7	500	24	4	CSF00129	
10½ 266.7	600	33	5	CSF00042	
10½ 266.7	725	40	6	CSF00044	CSF00045
10½ 266.7	850	47	7	CSF00209	
12 304.8	500	19	3	CSF00047	
12 304.8	900	34	5	CSF00053	CSF00054
14 355.6	750	23	3	CSF00056	CSF00057
14 355.6	1100	36	6	CSF00060	CSF00061
15¼ 387.4	1000	27	4	CSF00065	
15¼ 387.4	1250	33	5	CSF00143	CSF00067
17⅞ 454.0	1000	23	3	CSF00071	
17⅞ 454.0	1300	28	4	CSF00073	
17⅞ 454.0	1550	30	5	CSF00148	CSF00075
19½ 495.3	1250	24	4		CSF00077

Finned Strip Heaters with T4 Terminals

Stock Items Are Shown In **RED**

Length in mm	Wattage	Watt Density		Part Number	
		W/in ²	W/cm ²	120V	240V
19½ 495.3	1700	32	5	—	CSF00080
21 533.4	1900	33	5	CSF00158	CSF00085
23¼ 603.3	1000	15	2	—	CSF00528
23¼ 603.3	1450	22	3	—	CSF00088
23¼ 603.3	2200	33	5	—	CSF00090
25½ 647.7	2400	33	5	—	CSF00094
26¼ 679.5	2500	32	5	—	CSF00100
30¾ 774.7	1800	20	3	—	CSF00102
30¾ 774.7	2800	28	4	—	CSF00104
33½ 850.9	3150	31	5	—	CSF00180
35½ 911.2	2000	18	3	—	CSF00350
35½ 911.2	3450	31	5	—	CSF00110
42½ 1079.5	4150	31	5	—	CSF00117

NOTE: Type C – Terminal Box and Type P – High Temperature Quick Disconnect Plug are available. See page 8-6 for details.

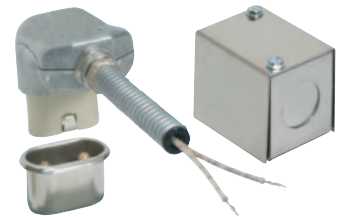

EHF — Finned Channel Strip Enclosure Heaters

Design Features

- * 10-32 offset screw terminals (T4 style) standard, other terminations available
- * UL recognized component
- * Stainless steel sheath and fins
- * Easy installation with special enclosure mounting brackets

Stock and Standard (Non-Stock) Series EHF Heaters

Stock Items Are Shown In **RED**

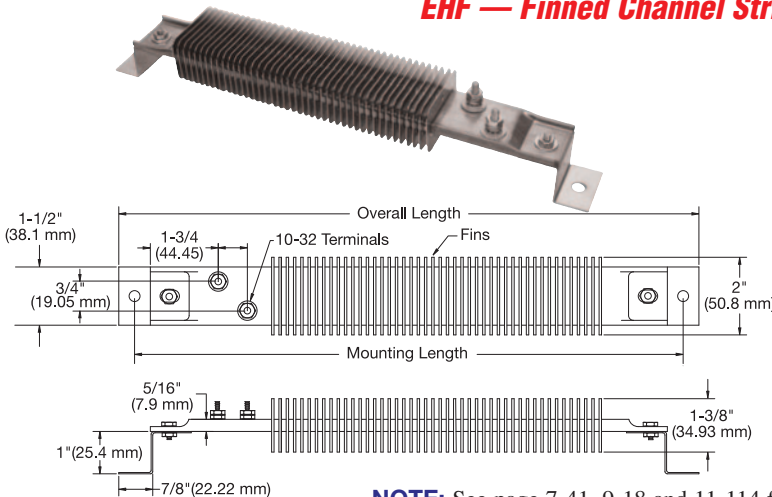

Overall Length	Mounting Dimension	Watts	Part Number	
			120V	240V
12.125	11.375	200	EHF00001	EHF00002
15.625	14.875	350	EHF00003	EHF00004
19.5	18.75	450	EHF00005	EHF00006
25.375	24.625	700	EHF00007	EHF00008

NOTE: See page 7-41, 9-18 and 11-114 for other type enclosure heaters.

Ordering Information

Catalog Heaters

Select a Finned Strip Heater from the Standard Sizes and Ratings lists on pages 8-14 and 8-15.

Finned Strip Heaters whose Part Numbers are in **RED** are available from Stock for immediate delivery.

Standard Non-Stock Part Numbers have a 3-week lead time.

Custom Engineered/Manufactured Heaters

An electric heater can be very application specific; for sizes and ratings not listed, **TEMPCO** will design and manufacture a Finned Strip Heater to meet your requirements. **Standard lead time is 3 weeks.**

Please Specify the following:

- Type of Application
- Length
- Wattage
- Voltage
- Termination Type
- Secondary Bushings (see page 8-13)
- Igloo™ Ceramic Terminal Covers

⚠ WARNING: Cancer and Reproductive Harm - www.P65Warnings.ca.gov.

(800) 323-6859 • Email: sales@tempco.com

MAXISTRIP®

**A Reliable Heat Source with
Excellent Heat Transfer
Capabilities Due to the
Aluminum Shoe Construction**

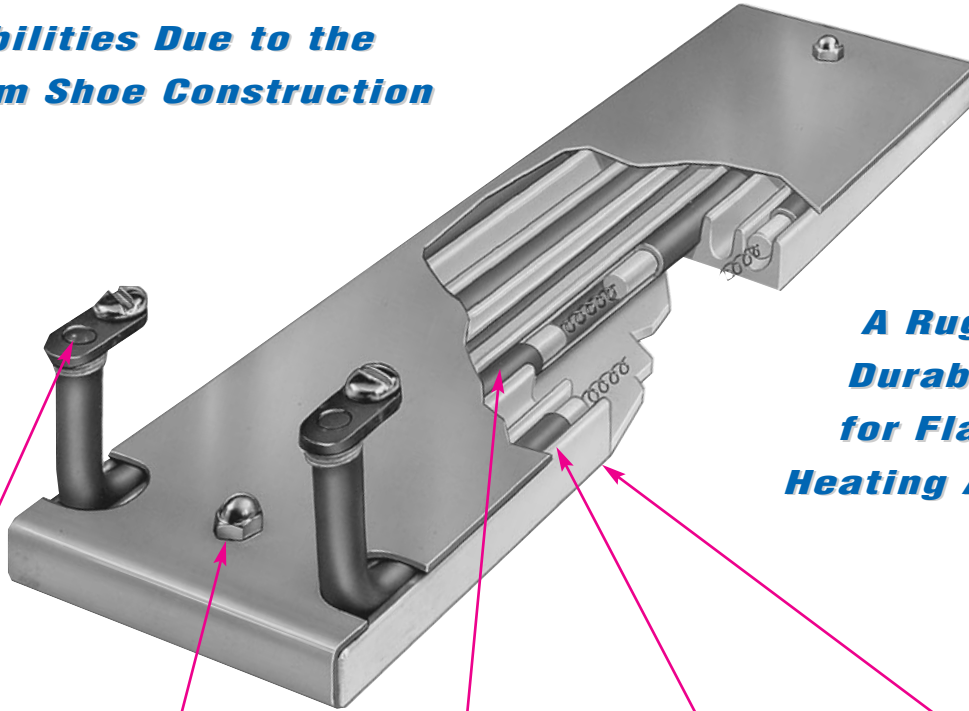

**A Rugged and
Durable Heater
for Flat Surface
Heating Applications**

A Right-angle lug terminals with 10-32 binding head screws provide ease of electrical wiring.

B Crown nuts securely fasten the cover plate to the aluminum track, keeping contaminants from coming in direct contact with the tubular heating element.

C Ruggedly constructed .315 diameter heating elements are the heat source for Maxistrip heaters, providing excellent life and long, trouble-free service.

D Specially designed aluminum track houses the tubular heating element, providing an excellent heat sink for rapid heat transfer and good temperature uniformity.

E The surface contact on Maxistrip heaters is extremely smooth and flat, which is essential for good heat conduction. This results in exceptionally long heater life.

TEMPCO Maxistrip Heaters are specially designed and engineered for trouble-free performance and more efficient heating of flat surfaces. Due to the rugged construction characteristics of this type of strip heater, it is highly recommended for applications requiring excellent heat transfer and temperature uniformity.

Design Features

- * Quick Installation
- * Contamination Proof
- * Various Lead Terminations
- * Excellent Heat Transfer
- * Excellent Temperature Uniformity
- * Designed for Durability and Trouble-Free Service

Typical Applications

- ➔ Extrusion Dies
- ➔ Molds
- ➔ Hot Plates
- ➔ Drying
- ➔ Incubators
- ➔ Platens
- ➔ Sealing Bars
- ➔ Thermoforming
- ➔ Tank Heating
- ➔ Food Warmers



Note: Mounting holes can be provided down the center. For other locations see drawings on page 8-17.

Specifications & Tolerances

Standard Specifications and Tolerances of Maxistrip Heaters.

If tighter tolerances are required, consult Tempco.

PERFORMANCE RATINGS

Maximum Sheath Temperature: 650°F (343°C)

Maximum Watt Density: 20 W/in² (3.1 W/cm²)

ELECTRICAL SPECIFICATIONS

Maximum Voltage: 277VAC

Maximum Recommended Voltage w/ Leads: 240VAC

Maximum Watts: Dependent on width and length

Maximum Amperage: 25 Amps

Resistance Tolerance: +10%, -5%

Wattage Tolerance: +5%, -10%

PHYSICAL SIZE CONSTRUCTION LIMITATIONS

Widths: 1-1/2" (38.1 mm), 2-1/2" (63.5 mm), 3" (76.2 mm), 4" (101.6 mm)

Thickness: 1/2" (12.7 mm)

Mounting Holes can be located only along the phantom lines between the holes shown on these drawings.

Standard Hole Diameter: 5/16"

Maximum Hole Diameter: 1/2"
(center of width only)

Mounting Holes

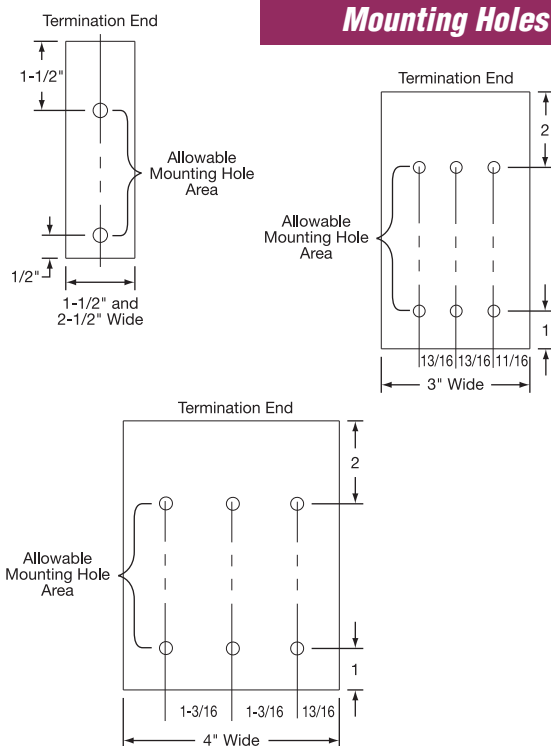

Screw Terminals

Type S Terminal Lugs

Terminal lugs with 10-32 binding head screws are the standard termination for all Maxistrip heaters.



Type T1 Straight Terminals

Straight outward screw terminals with 8-32 threads.



Type R 90° Blockhead Terminals

90° Blockhead Terminals with 10-32 threads. Special design can switch between 1800W and 900W at 240V.

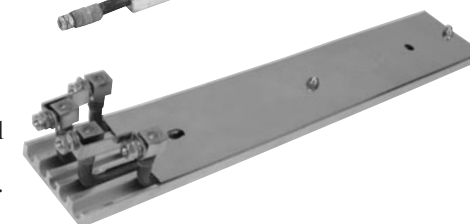

Abrasion Resistant Terminations

Wire braid provides strength and protection to the lead wire insulation, offering sharp bending not possible with armor cable. 20" of wire braid and 24" flexible leads are standard.

Options: Longer leads or braid. Male or female plugs attached to leads.

Type W1 Straight Wire Braid Leads

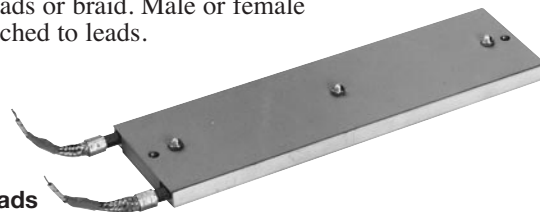

Type W2 Straight-Up Wire Braid Leads



Special Widths



By combining one or more standard width (1-1/2", 2-1/2", 3" and 4") aluminum strip heater channels, wider surface areas can be developed. Consult Tempco with your requirements.

Terminations

Abrasion Resistant Terminations

Type W3 Single Wire Braid Leads

Wire braid provides strength and protection to the lead wire insulation, offering sharp bending not possible with armor cable. 20" of wire braid and 24" flexible leads are standard.

Options: Longer leads or braid. Male or female plugs attached to leads.

Type R1 Single Armor Cable Leads

Armor Cable provides excellent protection against abrasion and contaminants. The cable exits through an adapter that encapsulates the element ends. The adapter and cable are silver soldered on for maximum security and seal protection. 20" of cable and 24" flexible leads are standard.

Type R1A Galvanized cable **Type R1B** Stainless steel cable

Options: Longer leads or cable. Male or female plugs attached to leads.

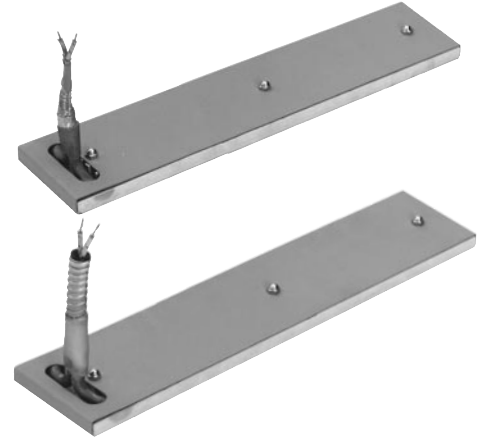

Type C General Purpose Stainless Steel Terminal Box

Terminal Boxes provide a simple and economical way to eliminate all live exposed terminals and electrical wiring that can be a potential hazard to employees or machines. Boxes have 1/2" trade size knockouts (actual diameter 7/8") for standard connections to simplify installation. Strip heaters fitted with boxes can be supplied factory prewired with leads, armor cable or braid.

Type CA Box only

Type CB Box with galvanized cable

Type CC Box with SS cable

Type CD Box with wire braid

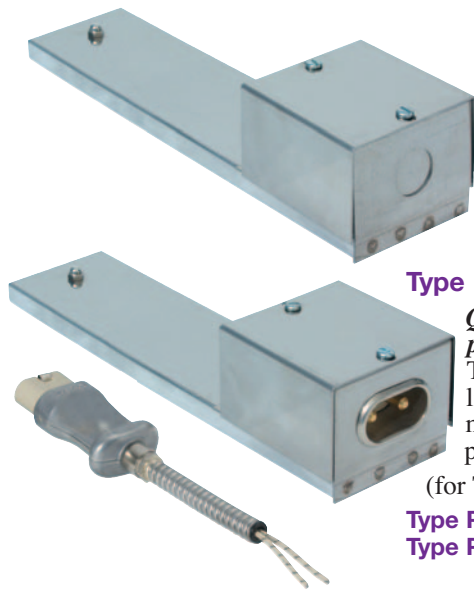

Type P2 Quick-Disconnect High Temperature Plug

Quick-Disconnect Plug assemblies are highly recommended and should be used whenever possible. They provide the simplest and safest way to apply power to strip heater installations. The combination of plug and cup assembly, along with armor cable cover leads, eliminates all live exposed terminals and electrical wiring that can be a potential hazard to employees and machines. To simplify installation, Maxistrips fitted with P2 plug assemblies can be supplied prewired, using high-temperature lead wire protected with armor cable or wire braid.

(for Type P on a 1-1/2" wide Maxistrip consult Tempco.)

Type P2A Box and cup only

Type P2C w/ straight plug and galvanized cable

Type P2D w/ straight plug and SS cable

Type P2E w/ straight plug and wire braid

Standard (Non-Stock) Sizes and Ratings

Width 1-1/2" (38.1 mm)

Length in mm	Wattage	Watt Density		Part Number	
		W/in ²	W/cm ²	120V	240V
3 1/2	88.9	130	25 4	MXS00001	—
3 3/4	95.3	140	25 4	MXS00002	—
4	101.6	150	25 4	MXS00003	—
4 1/4	108.0	160	25 4	MXS00004	—
4 1/2	114.3	170	25 4	MXS00005	—
4 3/4	120.7	180	25 4	MXS00006	—
5	127.0	190	25 4	MXS00007	—
5	127.0	150	20 3	MXS00008	—
5 1/4	133.4	200	25 4	MXS00009	—
5 1/2	139.7	205	25 4	MXS00010	—
5 3/4	146.1	215	25 4	MXS00011	—
6	152.4	225	25 4	MXS00012	—
6 1/4	158.8	230	25 4	MXS00013	—
6 1/2	165.1	240	25 4	MXS00014	—
6 3/4	171.5	250	25 4	MXS00015	—
7	177.8	260	25 4	MXS00016	—
7 1/4	184.2	270	25 4	MXS00017	—
7 1/2	190.5	170	15 2	MXS00018	—
7 1/2	190.5	225	20 3	MXS00019	—
7 1/2	190.5	280	25 4	MXS00020	MXS00021
7 3/4	196.9	290	25 4	MXS00022	MXS00023
8	203.2	240	20 3	MXS00024	MXS00025
8	203.2	300	25 4	MXS00026	MXS00027
8 1/4	209.6	310	25 4	MXS00028	MXS00029

Length in mm	Wattage	Watt Density		Part Number	
		W/in ²	W/cm ²	120V	240V
8 1/2	215.9	320	25 4	MXS00030	MXS00031
8 3/4	222.3	330	25 4	MXS00032	MXS00033
9	228.6	270	25 4	MXS00034	MXS00035
9	228.6	335	25 4	MXS00036	MXS00037
9 1/4	235.0	345	25 4	MXS00038	MXS00039
9 1/2	241.3	350	25 4	MXS00040	MXS00041
9 3/4	247.7	355	25 4	MXS00042	MXS00043
10	254.0	300	20 3	MXS00044	MXS00045
10	254.0	375	25 4	MXS00046	MXS00047
10 1/4	260.4	385	25 4	MXS00048	MXS00049
10 1/2	266.7	315	20 3	MXS00050	MXS00051
10 1/2	266.7	395	25 4	MXS00052	MXS00053
11	279.4	330	20 3	MXS00054	MXS00055
11	279.4	410	25 4	MXS00056	MXS00057
11 1/4	285.8	335	20 3	MXS00058	MXS00059
11 1/2	292.1	345	20 3	MXS00060	MXS00061
12	304.8	270	15 2	MXS00062	MXS00063
12	304.8	450	25 4	MXS00064	MXS00065
12	304.8	360	20 3	MXS00066	MXS00067
12 1/2	317.5	375	20 3	MXS00068	MXS00069
12 3/4	323.9	380	20 3	MXS00070	MXS00071
13	330.2	290	15 2	MXS00072	MXS00073
13	330.2	390	20 3	MXS00074	MXS00075
14	355.6	420	20 3	MXS00076	MXS00077



Standard (Non-Stock) Sizes and Ratings

Width 2-1/2" (63.5 mm)

Length in	mm	Wattage	Watt Density		Part Number	
			W/in ²	W/cm ²	120V	240V
3½	88.9	175	20	3	MXS00078	—
3¾	95.3	230	25	4	MXS00079	—
4	101.6	250	25	4	MXS00080	—
4½	114.3	280	25	4	MXS00081	—
5	127.0	310	25	4	MXS00082	—
5½	139.7	340	25	4	MXS00083	—
6	152.4	375	25	4	MXS00084	—
6½	165.1	325	20	3	MXS00085	—
6¾	171.5	335	20	3	MXS00086	MXS00087
7	177.8	435	25	4	MXS00088	MXS00089
7¼	184.2	360	20	3	MXS00090	MXS00091
7½	190.5	465	25	4	MXS00092	MXS00093
7¾	200.0	295	15	2	MXS00094	MXS00095
8	203.2	400	20	3	MXS00096	MXS00097
8	203.2	500	25	4	MXS00098	MXS00099
8¼	209.6	410	20	3	MXS00100	MXS00101
8½	215.9	530	25	4	MXS00102	MXS00103
9	228.6	560	25	4	MXS00104	MXS00105
9½	241.3	590	25	4	MXS00106	MXS00107
10	254.0	500	20	3	MXS00108	MXS00109
10	254.0	625	25	4	MXS00110	MXS00111
10½	266.7	650	25	4	MXS00112	MXS00113
11	279.4	550	25	4	MXS00114	MXS00115
11½	292.1	575	20	3	MXS00116	MXS00117
11½	292.1	715	25	4	MXS00118	MXS00119
12	304.8	600	20	3	MXS00120	MXS00121
12	304.8	750	25	4	MXS00122	MXS00123
12½	317.5	625	25	4	MXS00124	MXS00125
13	330.2	650	25	4	MXS00126	MXS00127
13½	342.9	675	25	4	MXS00128	MXS00129
14	355.6	700	20	3	MXS00130	MXS00131
14	355.6	875	25	4	MXS00132	MXS00133

Width 3" (76.2 mm)

Length in	mm	Wattage	Watt Density		Part Number	
			W/in ²	W/cm ²	120V	240V
6	152.4	450	25	4	MXS00134	MXS00135
6½	165.1	485	25	4	MXS00136	MXS00137
7	177.8	525	25	4	MXS00138	MXS00139
7½	190.5	560	25	4	MXS00140	MXS00141
8	203.2	600	25	4	MXS00142	MXS00143
8½	215.9	635	25	4	MXS00144	MXS00145
9	228.6	675	25	4	MXS00146	MXS00147
9½	241.3	710	25	4	MXS00148	MXS00149
10	254.0	600	20	3	MXS00150	MXS00151
10½	266.7	630	20	3	MXS00152	MXS00153
11	279.4	660	20	3	MXS00154	MXS00155
11½	292.1	690	20	3	MXS00156	MXS00157
12	304.8	720	20	3	MXS00158	MXS00159
12½	317.5	750	20	3	MXS00160	MXS00161
13	330.2	780	20	3	MXS00162	MXS00163
13½	342.9	810	20	3	MXS00164	MXS00165

Width 4" (101.6 mm)

Length in	mm	Wattage	Watt Density		Part Number	
			W/in ²	W/cm ²	120V	240V
6	152.4	600	25	4	MXS00166	MXS00167
7	177.8	700	25	4	MXS00168	MXS00169
8	203.2	800	25	4	MXS00170	MXS00171
9	228.6	900	25	4	MXS00172	MXS00173
10	254.0	1000	25	4	MXS00174	MXS00175
11	279.4	880	20	3	MXS00176	MXS00177
12	304.8	960	20	3	MXS00178	MXS00179
12½	317.5	1000	20	3	MXS00180	MXS00181
13	330.2	1040	20	3	MXS00182	MXS00183
13½	342.9	1080	20	3	MXS00184	MXS00185

Ordering Information

Catalog Heaters

Select a Maxistrip Heater from the Standard Sizes and Ratings lists above. Note that Part Numbers shown are for heaters with type "S" termination. Specify Part Number and Quantity. Lead time is 3 weeks.

Custom Engineered/Manufactured Heaters

An electric heater can be very application specific; for sizes and ratings not listed, **TEMPCO** will design and manufacture a Maxistrip Heater to meet your requirements. **Standard lead time is 3 weeks.**

Please Specify the following:

- Width
- Length
- Wattage
- Voltage
- Termination Types
- Lead Length
- Cable/Braid Length
- Optional Features

⚠ WARNING: Cancer and Reproductive Harm - www.P65Warnings.ca.gov.

(800) 323-6859 • Email: sales@tempco.com

MICA INSULATED

**Mica Insulated Strip Heaters
Are Used in Hundreds
of Industrial and Commercial
Heating Applications**

**AN ECONOMICAL,
PRACTICAL AND
RELIABLE
HEAT SOURCE
CAPABLE OF
PROVIDING
UNIFORM HEAT
TRANSFER TO
FLAT SURFACES**

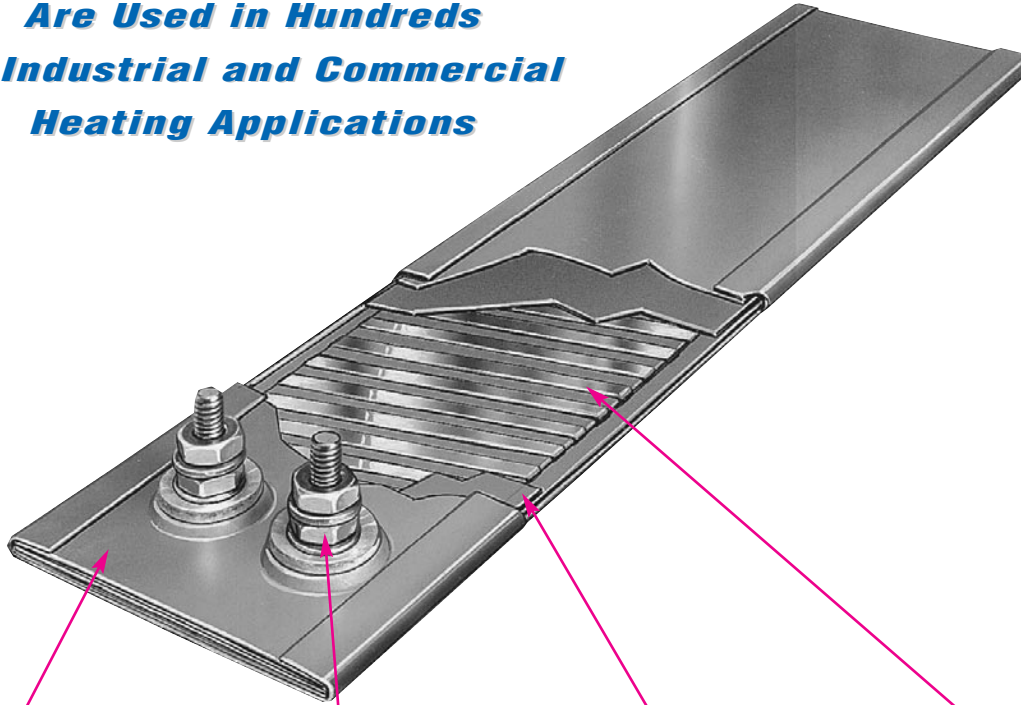

A Specially treated rust-resistant steel sheath casing provides the best combination of physical strength, high emissivity and good thermal conductivity for sheath temperatures up to 900°F (480°C). For corrosive atmospheres and/or sheath temperatures up to 1200°F (650°C), stainless steel sheath is available.

B For maximum connecting surface, the specially designed stainless steel screw terminals are securely fastened to a connecting jumper, assuring positive contact with the windings, providing maximum current carrying capacity. For other terminal or lead arrangements, see pages 8-22 and 8-23.

C Specially selected mica grade and thickness is used to insulate the windings, providing excellent thermal conductivity and dielectric strength.

D A specific nickel-chrome resistance ribbon wire size is properly engineered to achieve the best combination of wire gauge and spacing between turns, thereby providing the lowest winding temperature possible. The ribbon wire is wound on a specially selected Mica Strip, providing even heat distribution for maximum heater life.

Typical Applications

- ➔ Food Warming Equipment
- ➔ Packaging Equipment
- ➔ Blow Molding Equipment
- ➔ Testing Equipment
- ➔ Vulcanizing Presses
- ➔ Vending Machines
- ➔ Hot Plates
- ➔ Ovens
- ➔ Molds
- ➔ Kettles
- ➔ Incubators

Agency Approvals



Mica Strip heaters are UL recognized and CSA certified in many design variations. Tempco's UL file number is E65652 and CSA file number is 043099.

If you require UL, CSA, or other NRTL agency approvals, please specify when ordering.



Specifications & Tolerances

Standard Specifications and Tolerances of Mica Insulated Strip Heaters
If tighter tolerances are required consult Tempco. A heater's physical size combined with electrical ratings will determine the actual minimums and maximums.

PERFORMANCE RATINGS

Maximum Sheath Temperature

Rust resistant steel: 900°F (480°C)
Stainless Steel: 1200°F (650°C)

Nominal Watt Density: 5-45 W/in² (0.8-7.0 W/cm²)

Maximum Watt Density: Depends on operating temperature and heater size. 38 W/in² (5.9 W/cm²) Maximum when UL & CSA approval is required.

ELECTRICAL SPECIFICATIONS

Maximum Voltage: 480 Volts

Maximum Amperage: lead wire termination: 10 amp
screw terminations: 8-32UNF—20 amp; 10-32UNF—25 Amps

Resistance Tolerance: +10%, -5%

Wattage Tolerance: +5%, -10%

Formula for Calculating Watt Density

$$\text{Watt Density} = \frac{\text{Heater Wattage}}{(\text{Heater Width} - 3/8) \times (\text{Heater Length} - \text{Cold Area}^*)}$$

* Cold Area consists of Holes or Cutouts.

MATERIAL SPECIFICATIONS & PHYSICAL SIZES

Standard Sheath Material: Rust resistant steel

Optional: Stainless Steel or Aluminum

Nominal Thickness: 3/16" (4.76 mm)

Minimum Width: 5/8" (15.88 mm)
May vary depending on Termination

Width Tolerance: ±1/32" (0.79 mm)

Maximum Length: 72" (1829 mm)

Length Tolerance: Up to 24" (610 mm) ±1/16" (1.59 mm)
Over 24" (610 mm) ±1/8" (3.18 mm)

Screw Terminals

1" (25.4 mm) wide strips: 8-32 threads

Over 1" (25.4 mm) wide strips: 10-32 threads

Minimum Termination Distance from Edge of Heater

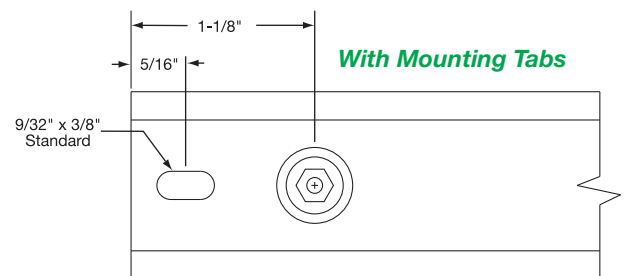
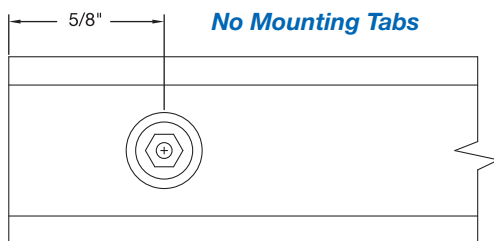

Installation

- Tempco Mica Insulated Strip Heaters are available with mounting slots at each end for surface mounting applications or without mounting slots for insertion into milled slots.
- For surface mounting installations, Mica Strip heaters must be clamped securely along their entire length to a smooth metal surface by using metal clamps 3" to 5" apart.
- Holes along the body of the strip heater for mounting purposes are not recommended and should only be used when there is no other means of clamping the strip heater down. These holes take up valuable winding space, increasing watt density, resulting in poor heater life.

Instructions

- When supported by mounting slots, the terminal end should be secured firmly. Opposite end should be slightly loosened to allow for linear expansion.
- The surface being heated must be clean and smooth for efficient heat transfer. Small air gaps caused by imperfections can cause hot spots, resulting in heater failure.
- Contaminants such as oil, plastics, and dirt should not be allowed to collect on heaters, as they will find their way into the heater windings, eventually carbonizing and causing electrical shorts.

Terminations

Screw Terminal Terminations

Type T1

Screw terminals at opposite ends.
Minimum Width required is 7/8".



Type T2

Screw terminals tandem at one end.
Minimum Width required is 7/8".

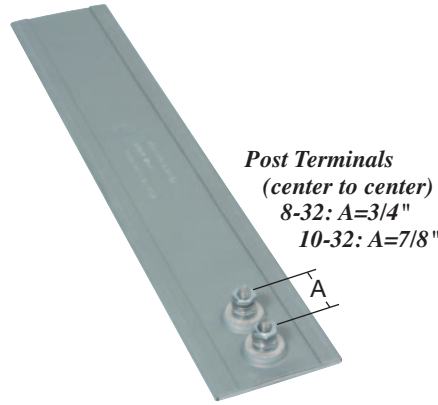

Type T3

Screw terminals parallel at one end.
Minimum Width required is 2".

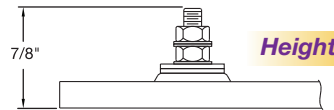

Note: Typical Termination locations shown (pages 8-22, 23). Specify terminal locations when ordering.

Terminal Protection

Type B__

Low-profile 10-32 button terminals with binding head screws. Same location and minimum width requirements as types T1, T2 and T3. 6-32 threads available.

- Type B1** Terminals at opposite ends (see T1)
- Type B2** Terminals same end (see T2)
- Type B3** Terminals same end (shown)

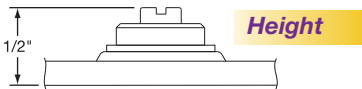
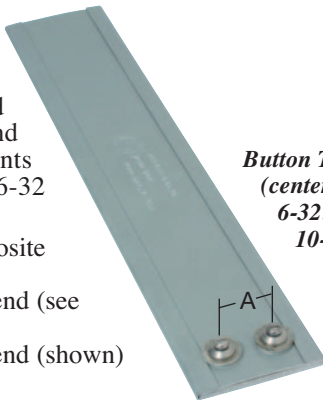

Type C__

Terminal box has one 1/2" trade size knockout (actual diameter 7/8") for ease of wiring. It provides excellent protection against exposed terminals. Boxes can be prewired with armor cable or wire braid.

- Type CA** Box only
- Type CB** Box with galvanized cable
- Type CC** Box with Stainless Steel cable
- Type CD** Box with wire braid

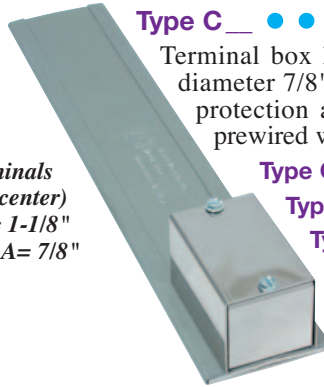

Type P1__

High-Temperature quick-disconnect plug. Available on 7/8" widths (depending on termination configuration) and wider with cup and plug assembly or just cup. Type P1Q shown with 90° plug and galvanized armor cable. Other options available. Consult Tempco.



Igloo™

Igloo ceramic terminal covers consist of two ceramic parts. With a tight-fitting cap and a solid base, an Igloo cover will fully insulate any standard 8-32 or 10-32 terminal lug used for electrical wiring hookup. Igloo covers can be assembled onto any standard mica strips with 10-32 screw terminals. Igloo covers are available in 3 different styles: single port, double port in-line and double port 90°. See page 15-13 for specific part numbers. Heater with double port in-line Igloo cover shown here.



Lead Wire Terminations

Type W1

Wire braid leads offer sharp bending not possible with armor cable. 10" of wire braid over 12" leads is standard. If longer braid or leads are required, specify.

Minimum Width required is 7/8".

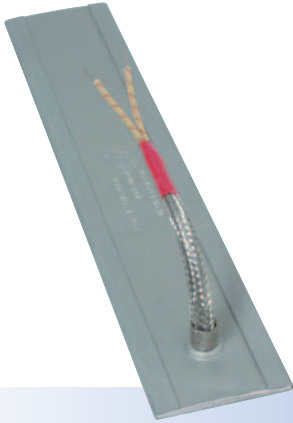

Type W2

Flexible stainless steel braided lead wires exiting at same end. 10" stainless steel braid over 12" leads is standard. If longer braid or leads are required, specify.

Minimum Width required is 1-1/8".

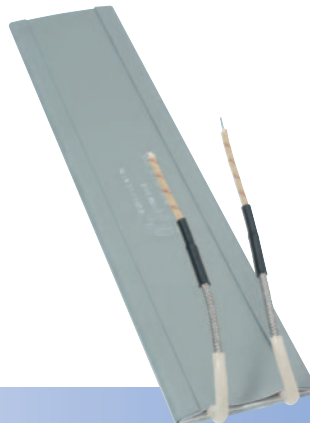

Type W3

Flexible stainless steel braided lead wires exiting at opposite ends. 10" stainless steel braid over 12" leads is standard. If longer braid or leads are required, specify.

Minimum Width required is 3/4".



Type L1

Flexible lead wire exiting from the top through a brass eyelet. 10" long leads standard; if longer leads are required, specify.

Minimum Width required is 7/8".



Type L2

Flexible lead wire exiting same end. 10" long leads standard; if longer leads are required, specify.

Minimum Width required is 1-1/8".

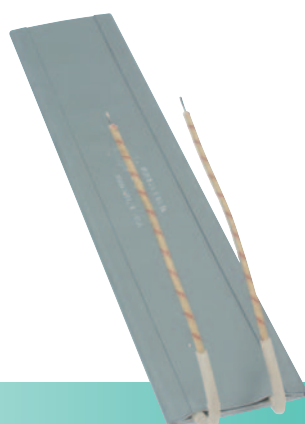

Type L3

Flexible lead wire exiting at opposite ends. 10" long leads standard; if longer leads are required, specify.

Minimum Width required is 3/4".



Abrasion Resistant Terminations

Type R1

Armor cable provides far superior protection to lead wires where abrasion is a constant problem. Available with two- or three-prong plugs. 10" of armor cable over 12" leads is standard. If longer cable, leads or plugs are required, specify.

Minimum Width required is 1".

- Type R1A** Galvanized cable, crimped
- Type R1B** Stainless Steel cable, crimped
- Type R1C** Galvanized cable, tack welded
- Type R1D** Stainless Steel cable, tack welded
- Type R1E** Galvanized cable, full silver brazing
- Type R1F** Stainless Steel, full silver brazing

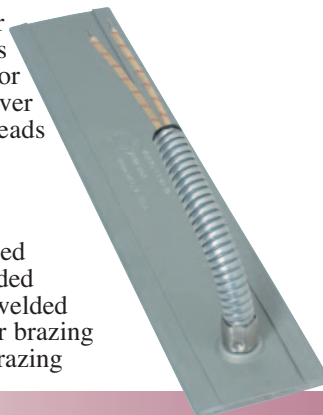

Type R2

Right-angle armor cable can be positioned in any direction. 10" of armor cable over 12" leads is standard. If longer leads are required, specify.

Minimum Width required is 1-1/4".

- Type R2A** Galvanized cable, crimped
- Type R2B** Stainless Steel cable, crimped
- Type R2C** Plain leads, no cable

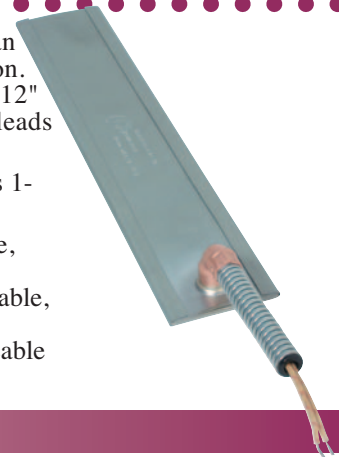



Standard Sizes and Ratings

Width		Length		Wattage	Watt Density		Termination	Part Number	
in	mm	in	mm		W/in ²	W/cm ²		120V	240V
1	25.4	6	152.4	100	32	5	L2	MSH00001	MSH00002
1	25.4	22½	571.5	525	39	6	W1	—	MSH00003
1¼	31.8	40	1016.0	750	31	5	R2	—	MSH00004
1½	38.1	5½	139.7	225	44	7	L1	—	MSH00005
1½	38.1	5½	139.7	225	44	7	L2	—	MSH00006
1½	38.1	5½	139.7	125	25	4	T2	MSH00007	—
1½	38.1	6	152.4	300	53	8	L2	MSH00008	—
1½	38.1	6	152.4	250	44	7	W1	—	MSH00009
1½	38.1	8	203.2	355	45	7	L2	—	MSH00010
1½	38.1	8	203.2	400	51	8	L2	MSH00011	MSH00012
1½	38.1	8	203.2	400	51	8	T2	MSH00013	—
1½	38.1	9½	241.3	200	21	3	L2	—	MSH00014
1½	38.1	10	254.0	450	44	7	L2	—	MSH00015
1½	38.1	10½	266.7	250	23	4	T2	MSH00016	—
1½	38.1	11	279.4	500	44	7	L1	—	MSH00017
1½	38.1	11	279.4	600	53	8	W1	—	MSH00018
1½	38.1	12	304.8	400	32	5	L2	MSH00019	—
1½	38.1	14	355.6	500	34	5	T2	MSH00020	—
1½	38.1	16	406.4	600	36	6	L2	—	MSH00021
1½	38.1	17	431.8	500	28	4	L1	—	MSH00022
1½	38.1	18	457.2	500	26	4	L2	MSH00023	—
1½	38.1	22½	571.5	775	32	5	W1	—	MSH00024
1½	38.1	24	609.6	1000	39	6	L2	—	MSH00025
1½	38.1	30	762.0	1000	31	5	L2	—	MSH00026
1½	38.1	36	914.4	1000	25	4	L2	—	MSH00027
1½	38.1	36	914.4	1000	25	4	T2	MSH00028	—
2	50.8	3	76.2	100	31	5	T2	—	MSH00029
2	50.8	4	101.6	20	4	1	T2	MSH00030	—
2	50.8	4	101.6	30	6	1	T2	MSH00031	—
2	50.8	4	101.6	40	8	1	T2	MSH00032	—
2	50.8	4	101.6	50	10	2	T2	MSH00033	—
2	50.8	4	101.6	100	21	3	T3	—	MSH00034
2	50.8	4	101.6	100	21	3	W1	—	MSH00035
2	50.8	4	101.6	150	31	5	W1	—	MSH00036
2	50.8	4	101.6	200	41	6	W1	—	MSH00037
2	50.8	8	203.2	275	24	4	L1	—	MSH00038
2	50.8	27½	698.5	1200	28	4	L2	—	MSH00039
2	50.8	43	1092.2	1400	21	3	T2	—	MSH00040
2⅞	61.9	5½	139.7	350	38	6	T3	—	MSH00041
2½	63.5	4	101.6	150	24	4	T1	—	MSH00042
2½	63.5	6	152.4	350	33	5	R1	—	MSH00043
2½	63.5	8½	215.9	350	22	3	T3	—	MSH00044
2½	63.5	10	254.0	350	18	3	L2	MSH00045	MSH00046
2½	63.5	14	355.6	625	23	4	L2	MSH00047	—
2⅞	73.0	6	152.4	300	24	4	T3	MSH00048	—
2⅞	73.0	6	152.4	300	24	4	T3	—	MSH00049
3	76.2	7	177.8	200	13	2	L1	MSH00050	—
3	76.2	7	177.8	500	32	5	L1	MSH00051	—
3	76.2	12	304.8	180	6	1	T1	MSH00052	—
3	76.2	12½	317.5	300	10	2	T3	—	MSH00053
3	76.2	15	381.0	500	14	2	L1	MSH00054	—
3	76.2	26	660.4	600	9	1	R1	—	MSH00055
3½	88.9	4	101.6	100	11	2	W2	—	MSH00056
3½	88.9	4½	114.3	500	46	7	W1	—	MSH00057
3½	88.9	7½	190.5	500	25	4	T3	MSH00058	—
3½	88.9	10	254.0	900	32	5	W2	—	MSH00059
3½	88.9	14	355.6	450	11	2	B3	MSH00060	—
4	101.6	4	101.6	275	25	4	R2	—	MSH00061
4	101.6	8	203.2	425	17	3	T3	—	MSH00062
4	101.6	11	279.4	750	21	3	T3	—	MSH00063
4	101.6	20	508.0	1750	25	4	R1	—	MSH00064
4⅞	111.1	7⅞	179.4	800	33	5	W2	—	MSH00065
4¾	120.7	5½	139.7	700	36	6	T2	—	MSH00066
4¾	120.7	11¼	285.8	200	4	1	T3	—	MSH00067
4⅞	123.8	11⅞	290.5	1200	26	4	T3	—	MSH00068
5⅞	149.2	11	279.4	425	8	1	R1	MSH00069	—
6	152.4	12	304.8	1200	19	3	T3	—	MSH00070
6	152.4	15	381.0	575	7	1	T3	—	MSH00071
7	177.8	11½	292.1	625	9	1	R1	MSH00072	—
8	203.2	9¼	235.0	450	7	1	T3	—	MSH00073
8	203.2	10	254.0	450	7	1	T3	—	MSH00074
10	254.0	18	457.2	300	2	0	B3	MSH00075	—

Standard (Non-Stock) Sizes and Ratings — Heaters Without Mounting Slots

Termination **Types L1** and **L2** have 10" leads.

R1 and **R2** have 10" galvanized armor cable over 12" leads.

W1 and **W2** have 10" stainless steel braid over 12" leads.

Stock Sizes and Ratings — Heaters With Mounting Slots

Termination Type T2: Post Terminals tandem at one end.

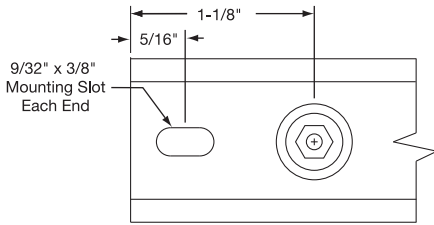

Width		Length		Wattage	Watt Density		Part Number	
in	mm	in	mm		W/in ²	W/cm ²	120V	240V
1½	38.1	4	101.6	75	30	5	MSH02258	MSH02259
3	76.2	4	101.6	120	19	3	MSH02273	MSH02272
1½	38.1	6	152.4	100	23	4	MSH02260	MSH02261
3	76.2	6	152.4	180	17	3	MSH02274	MSH02275
1½	38.1	8	203.2	150	22	3	MSH02262	MSH02263
3	76.2	8	203.2	240	16	2	MSH02276	MSH02277
1½	38.1	10	254.0	200	23	4	MSH02264	MSH02265
3	76.2	10	254.0	300	15	2	MSH02278	MSH02279
1½	38.1	12	304.8	300	28	4	MSH02266	MSH02267
3	76.2	12	304.8	360	15	2	MSH02280	MSH02281
1½	38.1	16	406.4	400	26	4	MSH02268	MSH02269
3	76.2	16	406.4	450	14	2	MSH02282	MSH02283
1½	38.1	24	609.6	600	26	4	MSH02270	MSH02271
3	76.2	24	609.6	600	14	2	MSH02284	MSH02285

Ordering Information

Catalog Heaters

Select a Mica Strip Heater from the Standard Sizes and Ratings List on pages 8-24 and 8-25. Specify Part Number and Quantity. Lead time is 2 weeks.

Custom Engineered/Manufactured Heaters

An electric heater can be very application specific; for sizes and ratings not listed, **TEMPCO** will design and manufacture a Mica Insulated Heater to meet your requirements. **Standard lead time is 2 weeks.**

Please Specify the following:

- Width
- Length
- Wattage
- Voltage
- Termination Type
- Lead Length
- Cable/Braid Length
- Optional Features

⚠ WARNING: Cancer and Reproductive Harm - www.P65Warnings.ca.gov.

Additional Mica Strip Heater Optional Features

Butt Case

Recommended for heating applications where strip heater will be placed in a milled slot between two steel plates.

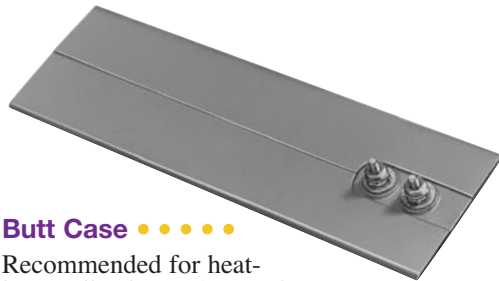

Pressure Plate

Strip Heaters can be made with built-in pressure plate to add rigidity and minimize warping of the heater. Standard plate thickness is 1/8". Specify plate thickness and choice of mounting method 1 or mounting method 2.

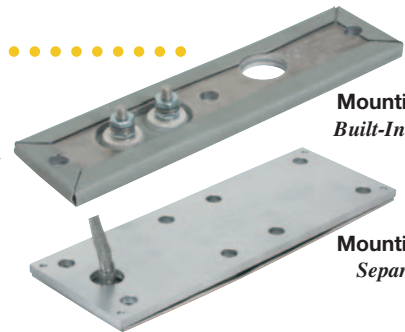

Four Sides Closed

Mica Strip Heaters can be closed on all four sides to reduce contamination from getting inside the heater. Recommended on all strip heaters over 2-1/2" in width.



Cross-Section-Formed

Strip Heaters can be formed on their cross section for pipe heating applications. 2" minimum width required. Specify diameter of pipe on which heaters are to be mounted.



CONTINUED →



Table Of Contents

Pictorial Index	A-22	Composite Curing Heater Blankets	9-19
Silicone Rubber and Kapton® Heaters	9-2	Drum Heaters	9-20
Design Guide.....	9-4	Quote Request Form	9-22
Common SHS/SHK Sizes	9-6	Rope Foil Heaters	9-23
Lead and Termination Options.....	9-9	Insulated Rope Heaters	9-24
Optional Design Features.....	9-11	Tubular Sheathed Rope Heaters	9-25
Mounting Methods.....	9-12	Adhesive Backed Heating Tape	9-26
Sensors	9-15	High Temperature Flexible Heating Tape .	9-28
Thermostats	9-16	Silicone Rubber Flexible Heating Tape....	9-30
Thermal Fuses	9-17	Silicone Rubber Flexible Heating Tape with	
PVC Pipe/Conduit Bending Heaters ...	9-17	Thermostat or Time Percent Control	9-31
Enclosure Heaters	9-18	Printed Thick Film Heating Elements	9-32

Flexible Heaters



section

Tempco Flexible Heaters: Silicone Rubber & Kapton® The Answer To Hundreds of Unique Heating Applications...

Designed for Trouble-Free Performance and Improved Operation Efficiency

Tempco's Flexible Heaters are capable of operating with excellent performance under many adverse conditions, including: moisture, outdoor exposure or ambient temperatures, radiation, ozone, compression set, vacuum, fungus, oils, solvents, and many other chemicals. The low thermal mass of flexible heaters allows their use in applications where the space for placing a heater is limited and weight is a concern.

Flexible Silicone Rubber and Kapton Heaters also have very good mechanical properties. They are of low mass construction and provide rapid heat-up due to direct bonding to the part— a desired requirement for applications where precise temperature control is important to the overall quality of the application. Flexible Heaters are not affected by mechanical shock, vibration or repeated flexing and will not stretch or tear over a temperature range of -70°F to +500°F (-56.6°C to +260°C).

Select a Flexible Heater for your specific application...

Tempco Flexible Heaters are a reliable and economical heat source capable of providing uniform heat transfer to irregular shaped or flat surfaces including three dimensional geometries, conforming to the part being heated. This flexibility allows you to design a heating element literally around the shape and size of the system, machine and/or component part.

Flexible heater use typically falls into the following applications:

- * Process Heat
- * Condensation Protection
- * Freeze Protection
- * Composite Bonding

Tempco's engineering staff, with many years of experience in heat processing and temperature control, can assist you in designing the right Silicone Rubber or Kapton Flexible Heater for your application.

Tempco's Flexible Heaters offer unlimited design possibilities!

Agency



Approvals

Tempco SHS, DHR & EHR Silicone Rubber Heaters are UL Recognized in the USA and for Canada under UL File Number E65652 (UL499) Component Recognition Program, and CSA Recognized under CSA File Number 043099.

If you require UL/cUL and/or CSA Agency Approval, please specify when ordering.

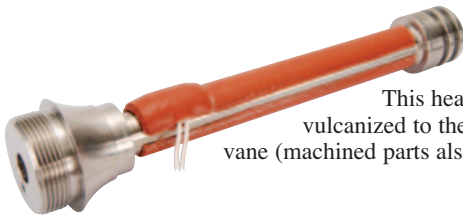

This heater, used for freeze protection, is vulcanized to the shaft in the base of a weather vane (machined parts also available from Tempco).

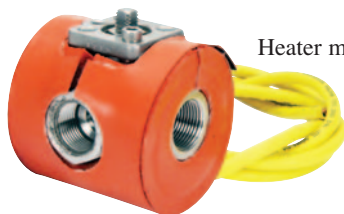

Heater manifold 3D formed for use on a snow making machine.



Heater vulcanized to black anodized aluminum for food-prep station (metal component also supplied by Tempco).

This formed heater is used to remove condensation on a vacuum canister.

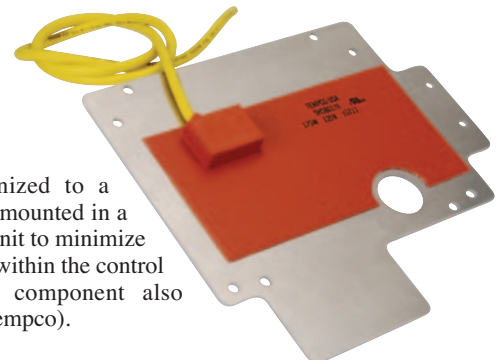
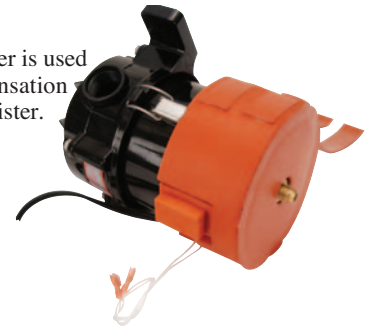

Heater vulcanized to a metal plate is mounted in a refrigeration unit to minimize condensation within the control panel (metal component also supplied by Tempco).

Flexible Heater Construction Characteristics

The texture of the fiberglass/silicone material can be “smooth” or “rough”. Smooth silicone tends to be more flexible and stain resistant. Rough silicone has a more durable texture. Standard construction of a plain wire-wound flexible heater is made with rough silicone. Smooth silicone is standard for heaters with PSA, vulcanized to a metal plate or other options or constructions that are deemed necessary by engineering. If smooth silicone is desired, please specify when ordering.

Flexible silicone rubber heaters can be produced using different material thicknesses and texture. Multiple layers can be applied for a thicker heater application. Overlapping the perimeter by 1/2" with the outer layers of a four-layer construction are more “moisture resistant” than standard two-layer construction giving that additional seal around the internal heater. Example: a 10" x 10" heater sandwiched between 11" x 11" outer layers.

The internal heat distribution pattern(s) allows for the heater element wire to be placed as close as 5/32" from the edge of the flexible heater. The heat pattern can be distributed to accommodate holes or cutouts, or to concentrate the heat in specific sections of the flexible heater as the application dictates.

Flexible heaters are produced in two heating element choices: wire-wound elements and etched foil elements (see page 9-4).

Typical Applications

- Aerospace
- Air Horns
- Aircraft Comfort Heaters
- Airplane Propeller Repair
- Animal Feeders
- ATM Machines
- Autoclaves
- Automotive
- Battery Heaters
- Computer Memory Planes
- Copy Machines
- Credit Card Scanners
- De-Icing
- Drum Heaters
- Food Service Equipment
- Graphic Arts Equipment
- Guidance Systems
- Gyroscopes
- Heated Presses
- Incubators
- Laboratory Equipment
- Laminators
- Liquid Reservoirs
- Medical Equipment
- Mirror Heaters
- Optical Equipment
- Outdoor Antennas
- Packaging Machinery
- Photo Processing
- Recovery Systems
- Refrigeration Equipment
- Security Equipment
- Semiconductor Equipment
- Shoe Machinery
- Turbine Propeller Repair
- Vacuum Chamber
- Vending Machines
- X-Ray Processing

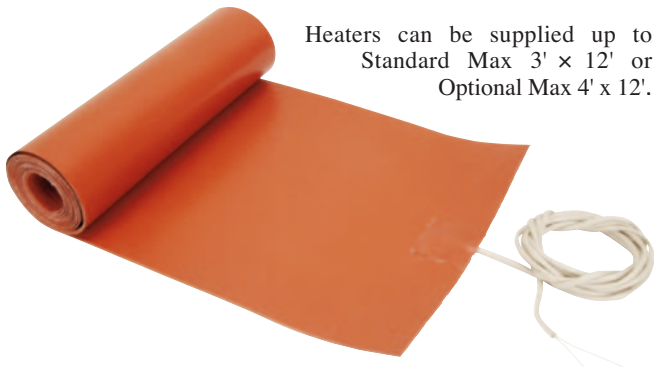

Heaters can be supplied up to
Standard Max 3' x 12' or
Optional Max 4' x 12'.

Small heater used to remove condensation in a gas filter is designed with two holes, two slits & Velcro® for easy installation while filter is in use.

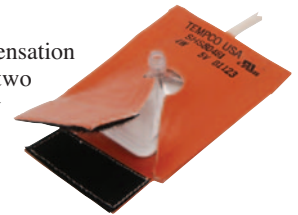

An insulating heater used on a compressor pump to prevent freezing in Siberia.

Round heater with a center hole used in air horns for motorized vehicles such as Trains, Semi Trucks, or RVs where the leads need to go through the center.



Cone heater used on a soup dispenser kettle.



Formed heater with six thermocouples for six-zone control used to refurbish airplane propellers by applying heat to cure an epoxy compound that attaches a new nickel lead edge to the propeller blade.



Standard Flexible Heater Specifications

SHS Silicone Rubber Heater Specifications

Physical Size and Construction Limitations

Maximum Size:	<i>Wire:</i> 36" × 144" (91.4 × 366 cm) <i>Foil:</i> 10" × 22" (25.4 × 56.9 cm)
Dimensional Tolerance:	
Less than 6":	±0.030" (0.76 mm)
6" to 12":	±0.060" (1.52 mm)
12" to 18":	±0.125" (3.17 mm)
18" to 36":	±0.250" (6.35 mm)
36" to 72":	±0.500" (12.7 mm)
Every 36" after 72":	Additional ±0.250" (6.35 mm)
Nominal Thickness:	<i>Wire:</i> 0.056" (1.42 mm) <i>Foil:</i> 0.030" (0.76 mm)
Available Thickness:	0.018" to 0.112" (0.46 mm to 2.85 mm)
Weight:	7 oz./ft ² (0.21g/cm ²)

Performance Ratings

Maximum Operating Temperature:	500°F / 260°C Intermittent 392°F / 200°C Continuous
Minimum Operating Temperature:	-70°F / -56.6°C
Physically Resistant To:	Moisture, Ozone, Fungus, Radiation
Agency Approvals:	UL File #E65652 (wire-wound only)

Electrical Ratings

Resistance Tolerance:	<i>Wire:</i> +10%, -5%, <i>Foil:</i> +10%, -10%
Maximum Operating Voltage:	<i>Wire:</i> 600 VAC, <i>Foil:</i> 480 VAC
Dielectric Strength:	1000 VAC
Standard Leads:	10" Teflon® Insulated Stranded Wire

SHK Kapton® Heater Specifications

Physical Size and Construction Limitations

Maximum Size:	10" × 22" (25.4 × 56.9 cm)
Dimensional Tolerance:	
Less than 6":	±0.030" (0.76 mm)
6" to 12":	±0.060" (1.52 mm)
Over 12":	±0.125" (3.17 mm)
Nominal Thickness:	0.008" (0.20 mm)
Weight:	1.5 oz./ft ² (0.05g/cm ²)

Performance Ratings

Maximum Operating Temperature:	392°F / 200°C Continuous
Minimum Operating Temperature:	-320°F / -195°C
Physically Resistant To:	Moisture, Ozone, Fungus

Electrical Ratings

Resistance Tolerance:	+10%, -10%
Maximum Operating Voltage:	480 Vac
Dielectric Strength:	1000 Vac
Standard Leads:	10" Teflon® Insulated Stranded Wire

Maximum Resistance Density for Heaters with Etched Foil Element: 125 Ω/in²



Note: Other materials are available, such as neoprene rubber or vinyl plastic. Consult Tempco for more information.

Wire-Wound Element Construction ●●●●●●●●●●

Tempco Silicone Rubber heaters with wire-wound elements provide excellent physical strength capable of withstanding repeated flexing without compromising the life and performance of the heater. They are also very effective for manufacturing geometrically challenged shapes, including three dimensional ones.

The wire-wound element process consists of resistance wire wound on a fiberglass cord for added support and flexibility. The wire-wound element is laid out in a special designed pattern to ensure uniform heat profile and to conform to the size and shape of the silicone rubber heater, avoiding holes and cutouts, or to concentrate the heat profile in a specific section(s) of the heater as the application dictates.

Power lead wires or cord sets are attached to the heater windings with solder and firmly secured in place through a vulcanizing process, ensuring that the assembly becomes homogenous.

The wire-wound process is recommended and preferred for small to medium size quantities, medium to large size heaters, and to produce prototypes to prove out the design parameters prior to entering into large volume production runs when using etched foil.

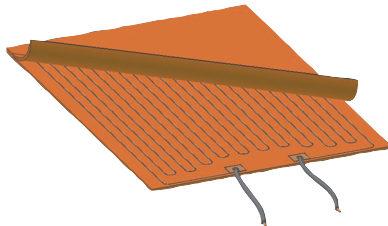

Etched Foil Element Construction ●●●●●●●●●●

Etched Foil Silicone Rubber or Kapton flexible heaters are made with a thin metal foil (.001"), usually a nickel base alloy, as the resistance element. The resistance pattern to be etched is designed in CAD and transferred to the foil, which is laminated to the insulating substrate. The element/substrate is then processed through an acid spray to produce the desired resistance pattern.

The top layer is then added and vulcanized for silicone rubber or laminated for Kapton heaters. For silicone rubber heaters, lead wires are then attached to the heater and insulated with additional silicone rubber to complete the heater. For Kapton® heaters, lead wires are attached to the heater and insulated with epoxy cement to complete the heater.

The etched foil heater has exceptional heat transfer compared to wire wound elements, due to its large flat surface area. It can deliver more uniform heat profiles with higher watt densities, providing longer operating heater life. It can also be zoned with distributed wattage or separate heating circuits to compensate for load variations. The etched foil process is recommended for small size heaters in large quantities.

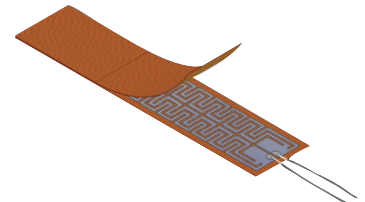

Flexible Heater Wattage Recommendations

Step 1 Determine the Required Wattage

Every process has a unique wattage requirement to heat that particular load up to temperature or to maintain a particular temperature.

If the required heater wattage is not known, estimate the required wattage using the thermodynamic formulas listed in chapter 16, Engineering. A safety factor of 25% additional wattage is recommended to compensate for unknown variables.

Example

To raise the temperature of an aluminum plate 6" x 12" x 0.5" (3.53 lb.) 200°F (from 70° to 270°F) in 0.5 hours:

$$\text{Watts} = \frac{3.53 \text{ lbs.} \times (0.24 \text{ Btu/lb.}^\circ\text{F}) \times 200^\circ\text{F}}{3.412 \text{ btu/watt hr.} \times 0.5 \text{ hrs.}} = 99 \text{ watts}$$

Add safety margin: 99 W + 25% = 124 watts

Step 2 Determine the Heater Size and Watt Density

A flexible heater should use the maximum space available for mounting and heating the process. Factors that affect heater size include the mounting method and watt density.

$$\text{Watt Density} = \frac{\text{Heater Wattage}}{\text{Area of the Heater}}$$

As a general rule, the following can be applied for silicone rubber heaters:

Low Heat-Up: 2.5 w/in²

Average Heat-Up: 5 w/in²

High Heat-Up: 7.5 w/in² and greater

Continuing the aluminum plate example, determine what size the heater should be:

Silicone Rubber Heater: 5" x 10" = 50 in²

Watt Density = 135 watts ÷ 50 in² = 2.7 watts/in²

Since the watt density falls between 2.5 and 5 w/in², the silicone rubber heater selected should work satisfactorily.

Referring to the chart below for a wire wound silicone rubber heater, pressure sensitive adhesive mounting should work well for this application at the required temperature.

If the calculated watt density is too high, a larger heater will lower the required watt density and still produce the same wattage.

Silicone Rubber Heater Surface Temperature vs. Watt Density

Graph shows the relationship between the maximum surface temperature and the watt density of standard silicone rubber heaters.

The heater was energized in still air without insulation or a load. Using this graph the designer can estimate the maximum temperature the heater can reach compared to the watt density of the heater.

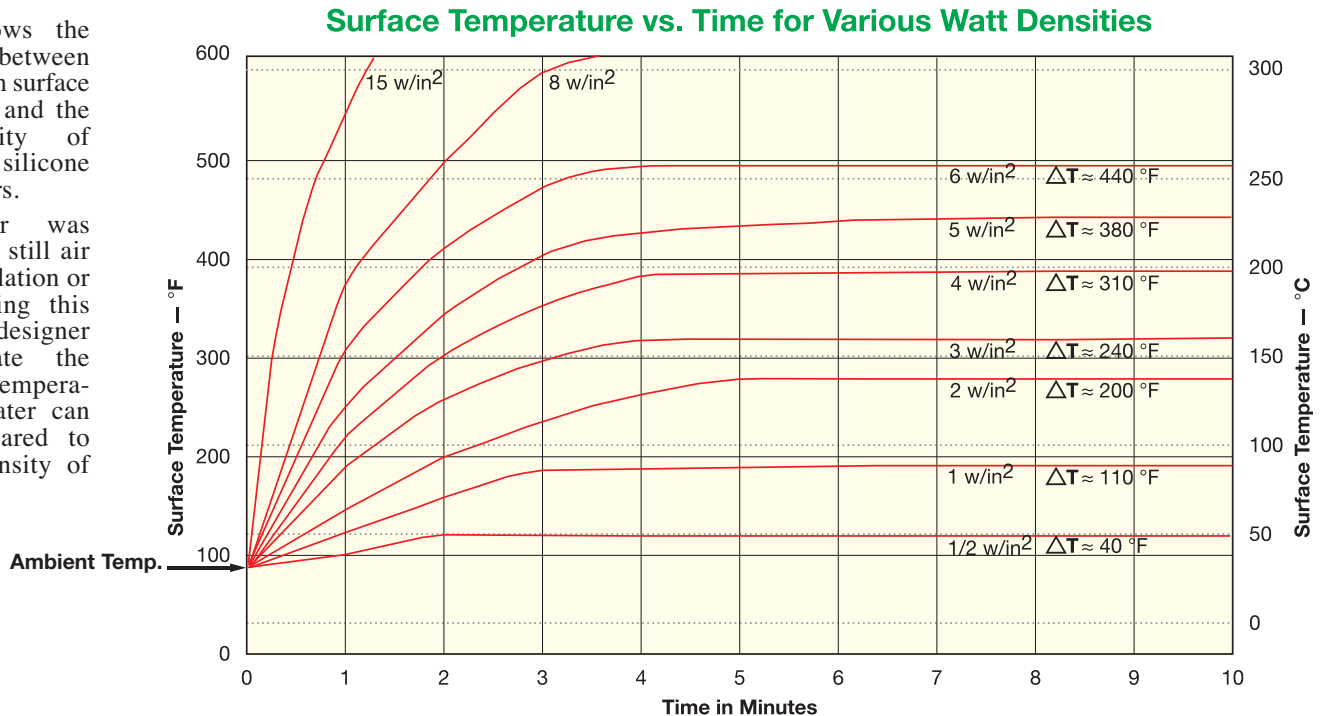

ΔT = Temperature Rise From Ambient at Specified Watt Densities

CONTINUED

Flexible Heater Wattage Recommendations

Continued from previous page...

Suggested Maximum Watt Density by Heater Type and Mounting Method

Watt Density w/in ²	Silicone Rubber – Wire Element		Silicone Rubber – Foil Element		Kapton® – Foil Element	
	Vulcanized	PSA	Vulcanized	PSA	Acrylic PSA	Acrylic PSA with 3 mil Aluminum Foil
5	420 to 356°F (216 to 180°C)	350 to 335°F (177 to 168°C)	455 to 419°F (235 to 215°C)	350 to 320°F (177 to 160°C)	212 to 189°F (100 to 87°C)	302 to 275°F (150 to 135°C)
10	356 to 266°F (180 to 130°C)	335 to 248°F (168 to 120°C)	419 to 383°F (215 to 195°C)	320 to 293°F (160 to 145°C)	189 to 163°F (87 to 73°C)	275 to 257°F (135 to 125°C)
15	266 to 158°F (130 to 70°C)	248 to 140°F (120 to 60°C)	383 to 347°F (195 to 175°C)	293 to 266°F (145 to 130°C)	163 to 131°F (73 to 55°C)	257 to 230°F (125 to 110°C)
20	158 to 68°F (70 to 20°C)	140 to 32°F (60 to 0°C)	347 to 311°F (175 to 155°C)	266 to 239°F (130 to 115°C)	131 to -25°F (55 to -32°C)	230 to 194°F (110 to 90°C)
25	68 to -40°F (20 to -40°C)	32 to -49°F (0 to -45°C)	— —	— —	— —	194 to 167°F (90 to 75°C)
30	— —	— —	311 to 257°F (155 to 125°C)	239 to 185°F (115 to 85°C)	— —	167 to 125°F (75 to 52°C)
35	— —	— —	— —	— —	— —	125 to 86°F (52 to 30°C)
40	— —	— —	257 to 185°F (125 to 85°C)	185 to 104°F (85 to 40°C)	— —	86 to -25°F (30 to -32°C)
50	— —	— —	185 to 50°F (85 to 10°C)	104 to -40°F (40 to -40°C)	— —	— —
60	— —	— —	50 to -49°F (10 to -45°C)	-40 to -49°F (-40 to -45°C)	— —	— —



Note: Use an appropriate Temperature Controller for the application.

Silicone Rubber Standard (Non-Stock) Sizes and Ratings

Silicone Rubber Heaters listed have 10" Teflon® Insulated Stranded Lead Wires exiting at Location L (see page 9-9).

Diameter in. mm	Area		Watts	Wire Construction		Foil Construction	
	in ²	cm ²		120V	240V	120V	240V
3.0	76	7.07	45.6	35	SHS00201	—	—
3.5	89	9.62	62.1	48	SHS00202	—	—
4.0	102	12.57	81.1	63	SHS00203	SHS00222	SHS00242
4.5	114	15.90	102.6	80	SHS00204	SHS00223	SHS00243
5.0	127	19.63	126.6	98	SHS00205	SHS00224	SHS00244
5.5	140	23.76	153.3	119	SHS00206	SHS00225	SHS00245
6.0	152	28.27	182.4	141	SHS00207	SHS00226	SHS00246
6.5	165	33.18	214.1	166	SHS00208	SHS00227	SHS00247
7.0	178	38.48	248.3	192	SHS00209	SHS00228	SHS00248
7.5	191	44.18	285.0	221	SHS00210	SHS00229	SHS00249
8.0	203	50.26	324.3	250	SHS00211	SHS00230	SHS00250
8.5	216	56.74	366.1	284	SHS00212	SHS00231	SHS00251
9.0	229	63.62	410.4	318	SHS00213	SHS00232	SHS00252
9.5	241	70.88	457.3	354	SHS00214	SHS00233	SHS00253
10.0	254	78.54	506.7	393	SHS00215	SHS00234	SHS00254
10.5	267	86.59	558.7	430	SHS00216	SHS00235	SHS00255
11.0	279	95.03	613.2	480	SHS00217	SHS00236	SHS00256
11.5	292	103.87	670.2	520	SHS00218	SHS00237	SHS00257
12.0	305	113.10	729.7	570	SHS00219	SHS00238	SHS00258
15.0	381	176.72	1140.2	880	SHS00220	SHS00239	SHS00259
20.0	508	314.16	2027.0	1570	SHS00221	SHS00240	SHS00260



**Silicone Rubber
Rounds**



Stock Square & Rectangular Silicone Rubber Heaters

Standard Smooth Silicone Rubber Heater

Heater with Pressure Sensitive Adhesive (PSA) Backing

Maximum Operating Temperature: 450°F (232°C)

Maximum Operating Temperature: 300°F (149°C)

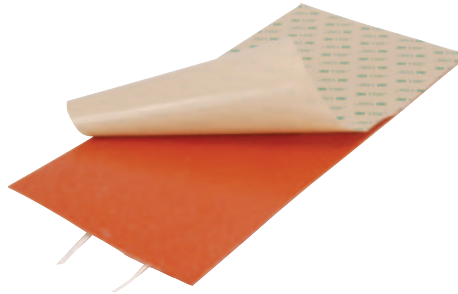

Use an appropriate method of temperature control to prevent heaters from exceeding maximum operating temperature. Reference Surface Temperature vs. Watt Density graph on page 9-5.



Stock Silicone Rubber Heaters — Standard Smooth and with Pressure Sensitive Adhesive Backing (PSA)

Silicone Rubber Heaters listed are 120 Volt and have 10" Teflon® Insulated Stranded Lead Wires exiting at Location A (see page 9-9).

Width		Length		Watts	Watt Density w/in ²	Part Number	
in.	mm	in.	mm			Standard (No PSA)	With PSA Backing
2	51	2	51	10	2.5	SHS80293	SHS80294
2	51	2	51	20	5	SHS80295	SHS80296
3	76	3	76	25	2.5	SHS80297	SHS80298
3	76	3	76	45	5	SHS80299	SHS80300
3	76	3	76	90	10	SHS80301	SHS80302
6	152	6	152	90	2.5	SHS80303	SHS80304
6	152	6	152	180	5	SHS80305	SHS80306
6	152	6	152	360	10	SHS80307	SHS80308
9	229	9	229	200	2.5	SHS80309	SHS80310
9	229	9	229	400	5	SHS80311	SHS80312
9	229	9	229	800	10	SHS80313	SHS80314
10	254	10	254	250	2.5	SHS80315	SHS80316
10	254	10	254	500	5	SHS80317	SHS80318
10	254	10	254	1000	10	SHS80319	SHS80320
12	305	12	305	360	2.5	SHS80321	SHS80322
12	305	12	305	720	5	SHS80323	SHS80324
12	305	12	305	1440	10	SHS80325	SHS80326
1	25	3	76	10	2.5	SHS80327	SHS80328
1	25	3	76	15	5	SHS80329	SHS80330
1	25	3	76	30	10	SHS80331	SHS80332
1	25	6	152	15	2.5	SHS80333	SHS80334
1	25	6	152	30	5	SHS80335	SHS80336
1	25	6	152	60	10	SHS80337	SHS80338
1	25	9	229	25	2.5	SHS80339	SHS80340
1	25	9	229	50	5	SHS80341	SHS80342
1	25	9	229	90	10	SHS80343	SHS80344
1	25	12	305	30	2.5	SHS80345	SHS80346
1	25	12	305	60	5	SHS80347	SHS80348
1	25	12	305	120	10	SHS80349	SHS80350
1	25	18	457	45	2.5	SHS80351	SHS80352
1	25	18	457	90	5	SHS80353	SHS80354
1	25	18	457	180	10	SHS80355	SHS80356
1	25	24	610	60	2.5	SHS80357	SHS80358
1	25	24	610	120	5	SHS80359	SHS80360
1	25	24	610	240	10	SHS80361	SHS80362
1	25	30	762	75	2.5	SHS80363	SHS80364
1	25	30	762	150	5	SHS80365	SHS80366
1	25	30	762	300	10	SHS80367	SHS80368

Width		Length		Watts	Watt Density w/in ²	Part Number	
in.	mm	in.	mm			Standard (No PSA)	With PSA Backing
1	25	48	1219	120	2.5	SHS80369	SHS80370
1	25	48	1219	240	5	SHS80371	SHS80372
1	25	48	1219	480	10	SHS80373	SHS80374
1	25	60	1524	150	2.5	SHS80375	SHS80376
1	25	60	1524	300	5	SHS80377	SHS80378
1	25	60	1524	600	10	SHS80379	SHS80380
1	25	72	1829	180	2.5	SHS80381	SHS80382
1	25	72	1829	360	5	SHS80383	SHS80384
1	25	72	1829	720	10	SHS80385	SHS80386
2	51	6	152	30	2.5	SHS80387	SHS80388
2	51	6	152	60	5	SHS80389	SHS80390
2	51	6	152	120	10	SHS80391	SHS80392
2	51	9	229	45	2.5	SHS80393	SHS80394
2	51	9	229	90	5	SHS80395	SHS80396
2	51	9	229	180	10	SHS80397	SHS80398
2	51	12	305	60	2.5	SHS80399	SHS80400
2	51	12	305	120	5	SHS80401	SHS80402
2	51	12	305	240	10	SHS80403	SHS80404
3	76	6	152	45	2.5	SHS80405	SHS80406
3	76	6	152	90	5	SHS80407	SHS80408
3	76	6	152	180	10	SHS80409	SHS80410
3	76	9	229	70	2.5	SHS80411	SHS80412
3	76	9	229	140	5	SHS80413	SHS80414
3	76	9	229	280	10	SHS80415	SHS80416
3	76	12	305	90	2.5	SHS80417	SHS80418
3	76	12	305	180	5	SHS80419	SHS80420
3	76	12	305	360	10	SHS80421	SHS80422
6	152	12	305	180	2.5	SHS80423	SHS80424
6	152	12	305	360	5	SHS80425	SHS80426
6	152	12	305	720	10	SHS80427	SHS80428
6	152	24	610	360	2.5	SHS80429	SHS80430
6	152	24	610	720	5	SHS80431	SHS80432
6	152	24	610	1440	10	SHS80433	SHS80434
9	229	12	305	270	2.5	SHS80435	SHS80436
9	229	12	305	540	5	SHS80437	SHS80438
9	229	12	305	1080	10	SHS80439	SHS80440
12	305	24	610	720	2.5	SHS80441	SHS80442
12	305	24	610	1440	5	SHS80443	SHS80444

(800) 323-6859 • Email: sales@tempco.com

Flexible Heaters



Standard Sizings and Ratings

Kapton® Standard (Non-Stock) Sizes and Ratings



**Kapton
Rounds**

Diameter		Area		Watts	Part Number	
in.	mm	in ²	cm ²		120V	240V
3.0	76	7.07	45.6	35	SHK00101	—
3.5	89	9.62	62.1	48	SHK00102	—
4.0	102	12.57	81.1	63	SHK00103	—
4.5	114	15.90	102.6	80	SHK00104	SHK00116
5.0	127	19.63	126.6	98	SHK00105	SHK00117
5.5	140	23.76	153.3	119	SHK00106	SHK00118
6.0	152	28.27	182.4	141	SHK00107	SHK00119
6.5	165	33.18	214.1	166	SHK00108	SHK00120
7.0	178	38.48	248.3	192	SHK00109	SHK00121
7.5	190	44.18	285.0	221	SHK00110	SHK00122
8.0	203	50.26	324.3	250	SHK00111	SHK00123
8.5	216	56.74	366.1	284	SHK00112	SHK00124
9.0	229	63.62	410.4	318	SHK00113	SHK00125
9.5	241	70.88	457.3	354	SHK00114	SHK00126
10.0	254	48.54	506.7	393	SHK00115	SHK00127

KAPTON FLEXIBLE HEATERS



**Kapton
Squares
and
Rectangle**

Width		Length		Watts	Part Number	
in.	mm	in.	mm		120V	240V
1	25	8	203	40	SHK00001	—
1	25	12	305	60	SHK00002	SHK00022
2	51	2	51	20	—	SHK00023
2	51	4	102	40	SHK00004	SHK00024
2	51	8	203	80	SHK00005	SHK00025
2	51	12	305	120	SHK00006	SHK00026
3	76	4	102	60	SHK00007	SHK00027
3	76	8	203	120	SHK00008	SHK00028
3	76	12	305	180	SHK00009	SHK00029
4	102	4	102	80	SHK00010	SHK00030
4	102	8	203	160	SHK00011	SHK00031
4	102	12	305	240	SHK00012	SHK00032
5	127	6	152	150	SHK00013	SHK00033
5	127	10	254	250	SHK00014	SHK00034
5	127	12	305	300	SHK00015	SHK00035
6	152	6	152	180	SHK00016	SHK00036
6	152	10	254	300	SHK00017	SHK00037
6	152	12	305	360	SHK00018	SHK00038
8	203	8	203	320	SHK00019	SHK00039
8	203	12	305	480	SHK00020	SHK00040
10	254	10	254	500	SHK00021	SHK00041

Ordering Information

Catalog Heaters

Chose from the tables of common sizes of Silicone Rubber and Kapton in round or rectangular shapes.

The heaters listed are 5 W/in². Standard configuration includes 10" Teflon® leads, exit style A or L (see page 9-9) and no mounting option.

Custom Engineered/Manufactured Heaters

An electric heater can be very application specific; for sizes and ratings not listed, **TEMPCO** will design and manufacture a Flexible Surface Heater to meet your requirements. **Standard lead time is 4 to 5 weeks.**

Please Specify the following:

- Diameter
- Wattage and Voltage
- Lead Type
- Sensors or Thermostats
- Special Features or Cutouts
- Lead Location

⚠ WARNING: Cancer and Reproductive Harm - www.P65Warnings.ca.gov.

Flexible Heater Lead End Termination Options

Tempco's standard lead termination is stripped lead ends — 1/4" (6.3mm). Any type of connector can be attached to the leads to complete the assembly and make wiring into applications quick and easy.

From simple ring crimp connectors to complex male or female crimp pins and housings such as Molex® components, Tempco does it all!

Tempco's expert designers and assemblers can also provide complete wire harnesses if required. Consult Tempco with your requirements.

Crimp Connectors: insulated or non-insulated

- Ring Terminal
- Spade Terminal
- 1/4" Female Straight Disconnect
- 1/4" Female Right-Angle Disconnect

Miniature Connectors: example – Molex

Plugs:

- Standard 120 or 240 Vac – straight blade
- Twist locking plugs, 120 to 480 Vac
- Specify NEMA or manufacturer's part number

Special Connectors and Plugs:

- Consult Tempco with your requirements.

Flexible Heater Lead Exit Location Options

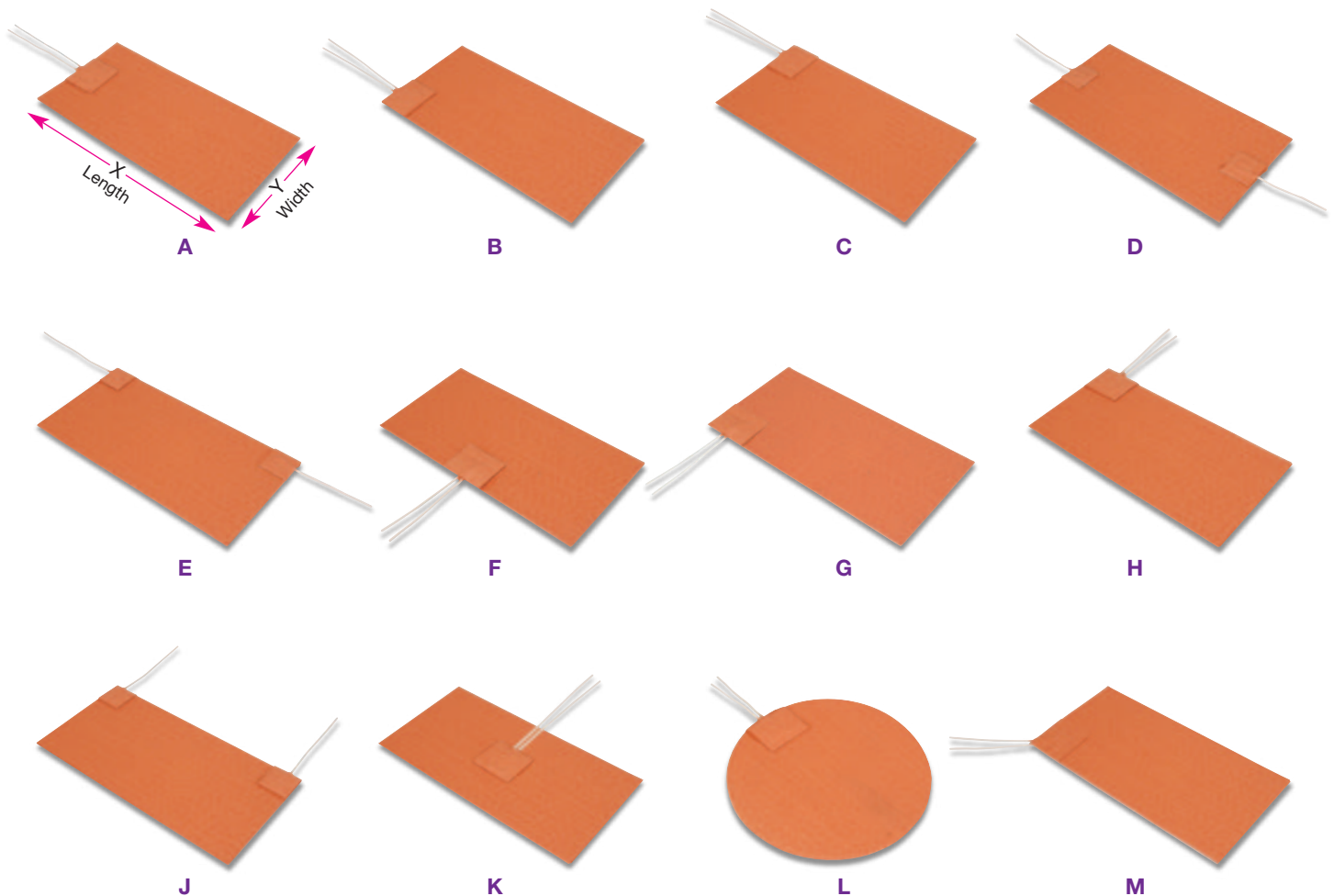

- Notes:**
1. Oriented so X is always greater than Y.
 2. Specify lead exit location using identification letters A through M.
 3. Provide a sample and/or drawing indicating power leads or cord set exit location for shapes other than those shown above.

Lead and Termination Options

Flexible Heater Lead Options

Standard Leads — Teflon®

Tempco's standard leads are 10" long, Teflon® insulated, flexible, stranded, plated copper wire. Stripped: 1/4"

- UL1180 rated 300V 200°C
- UL1199 rated 600V 200°C

On silicone rubber heaters, the lead connections are insulated with vulcanized silicone rubber, which also acts as a strain relief.

For Kapton® insulated heaters, high temperature epoxy is used to insulate and reinforce the lead connection.



Optional Leads

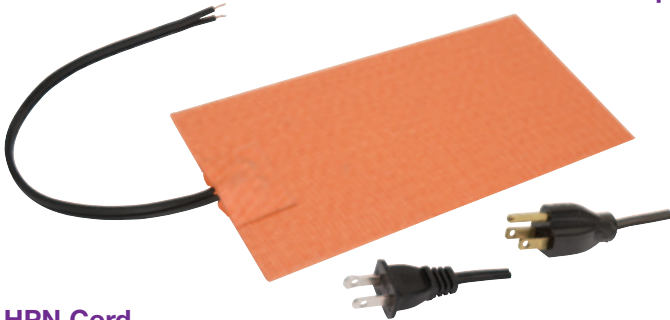

HPN Cord

For portable heaters, a two-conductor neoprene cordset can be vulcanized to the heater in any desired length.

HPN Cord and Plug Set

A two-conductor neoprene cord and plug set can be vulcanized to the heater. Standard Length: 6 ft. (1.83 M), 7 ft. (2.13M), or custom length as specified. Supplied with standard straight blade ungrounded plug, or grounded plug. 120Vac only.

- 2-Pole 2 wire non-grounding (NEMA 1-15P)
- 2-Pole 3 wire grounding (NEMA 5-15P)

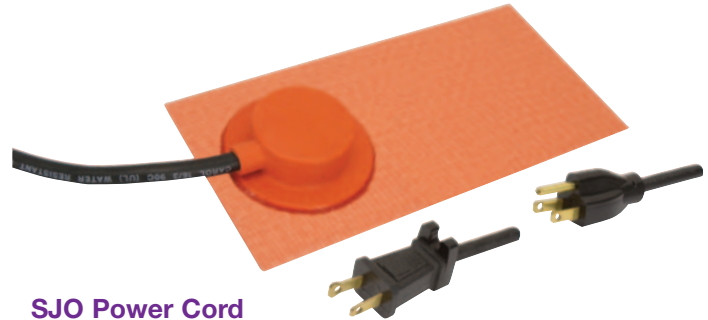

SJO Power Cord

For industrial applications, SJO heavy duty power cords can be attached to the heaters in any desired length.

SJO Power Cord and Plug Set

SJO heavy duty power cord and plug set can be attached to the heaters. Standard Length: 6 ft. (1.83 M), or custom length as specified. Supplied with standard straight blade ungrounded plug, or grounded plug. 120Vac only. (For 240Vac see page 15-15 for optional plugs)

- 2-Pole 2 wire non-grounding (NEMA 1-15P)
- 2-Pole 3 wire grounding (NEMA 5-1)



Silicone Rubber Leads

Ensures a moisture seal on the heater. Due to the similarity in material, the heater will fuse to the leads during the vulcanization process. Silicone rubber leads are more flexible, but are not as abrasion resistant as Teflon® leads.

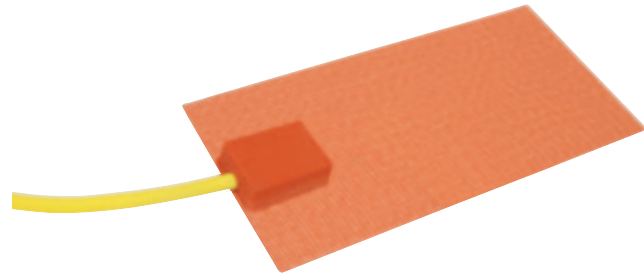

Built-Up Molded Lead Exit

Used to encase lead exit and optional snap action thermostat. (See page 9-15 for thermostat specifications) Shown with SJO cord rated -50°C to 105°C.

Special Lead Options

Special lead wire types and lengths in many configurations can be done. Consult Tempco.

Abrasion Protection Options

Various materials can be put over Teflon® or Silicone Rubber leads to provide mechanical or abrasion protection. The leads exit the heater as a single unit.

- Silicone Rubber/Fiberglass Sleeving (356°F/180°C)
- Heat Shrink Sleeving

Flexible Heater Optional Design Features



Internal Ground Screen Plane

Some applications may require the heater to be grounded. Due to the fact that the heater sheath is non-conductive, this can only be done artificially. A second layer of insulating material and a conductive grid can be added to the heater. A ground wire is attached to the grid.

A less expensive alternative for setting up a ground wire, especially for the required ground lead of a cordset, is to have a “flying ground lead” (6" long, green) exit the lead patch for attaching to the metal load surface, effectively grounding the process.

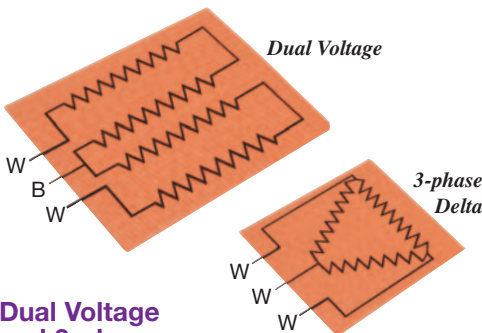

Dual Voltage and 3-phase

Due to the flexibility in circuit design for flexible heaters, heating circuits can be designed to accommodate dual voltage. On dual voltage heaters, three leads, including a common in a different color, are provided for wiring the heater in series for the higher voltage and parallel for the lower voltage. 120/240 Vac or 240/480 Vac can be specified. (see page 16-11 for more information)

Three-phase circuits can also be designed for large high-current applications.

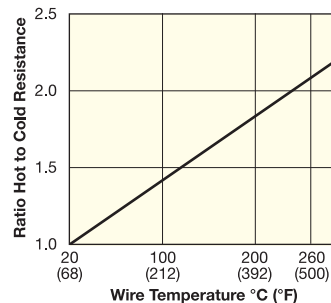

Self-Limiting/Self-Regulating Wire Wound Heater

The alloy used for this heater’s resistance wire has a high positive temperature coefficient of resistance that allows the heater to reduce power as temperature increases. This self-regulating feature is ideal for many low temperature applications. This feature can also be beneficial when a fast start-up time is required before the heater power levels off to normal operating temperature. See Chart for Ratio of Hot to Cold Resistance of the Heater wire at various wire temperatures.



Thermal Sponge Insulation and Thermal Conductive Sponge

To increase heater efficiency, silicone sponge rubber insulation can be bonded to the top side of the heater. Available thicknesses are 1/16", 1/8", 1/4", 3/8" or 1/2".

Thermal Conductive Sponge can be used to transfer heat evenly to various surfaces. Available in 1/8" thickness.



Foil Backing

Aluminum foil can be added to the back of the heater to help dissipate the heat between element runs and eliminate hot spots. Due to the foil, higher watt densities and better temperature uniformity can be attained. The foil would be applied to the back of the heater, on the mounting surface.

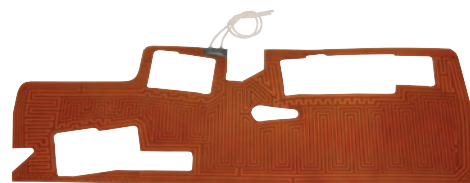

Distributed Wattage

In order to compensate for heating losses around the edges or mounting holes, the heating circuit can be designed in a distributed wattage pattern. More wattage can be added to the high loss areas to compensate for the higher losses.



Lead Exit Tab

An unheated lead exit tab can be added to the heater for a variety of reasons such as maintaining a rectangular heater with no cold sections or when used in a compression application to remove the lead exit area from between the plates. (Standard 2" x 2")



Multiple Zones

Multiple circuit areas can be zoned to compensate for various heating effects desired. In the picture above there are three zones with separate leads (A, B, and C).



Holes and Cutouts

Holes and cutouts in the surface of a silicone rubber or Kapton® heater can generally be placed anywhere in the heater assembly. Holes and cutouts can be used to allow space for bolts, nuts, temperature sensors, brackets, etc. For most holes and cutouts, a detailed drawing will be required for quoting or ordering.

Mounting Methods

Flexible Heater Pressure Sensitive Adhesive (PSA)

PSA

For ease of attachment specify PSA. Installation is simple: just peel off the protective liner and apply. It will adhere to most clean smooth surfaces. Care must be taken when installing to attain a smooth, consistent, uniform bond to achieve maximum results.

Maximum Temperature:

Continuous – 300°F (149°C)
Intermittent – 500°F (260°C)

Recommended Watt Density:

Under 5 W/in² (0.78 W/cm²)

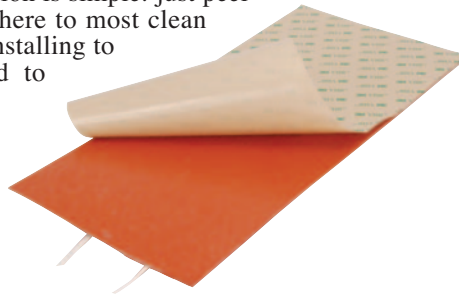

Note: To obtain the expected life of **Silicone Rubber** or **Kapton®** heaters, *care must be taken to mount correctly*. Regardless of the mounting technique used, do not trap any air under the heater; this can cause hot spots and possible premature heater failure. Use a rubber roller over the heater surface to assure good adhesion.

PSA Plus

A layer of aluminum foil is vulcanized to the back of the heater for added heat dissipation prior to the application of PSA.

Flexible Heater Factory Vulcanizing to Metal Component

Factory Vulcanizing

Flexible heaters can be factory vulcanized to bare or anodized aluminum, Stainless Steel, Marble, or other hard surfaces for permanent attachment and excellent heat transfer.

The uncured silicone rubber heater is placed on the metal part and placed in the vacuum oven where the heater vulcanizes and adheres to the part in one operation. This procedure forms an extremely strong permanent bond with most metals due to the fact that the silicone rubber flows into and fills the micro structure in the surface of the metal. The metal part can be manufactured by Tempco or supplied by the customer. Consult Tempco for other materials including granite.



Flexible Heater Magnetic Mounting

Magnetic Mounting

A flexible magnetic material can be attached to the back of a silicone rubber flexible heater. Will adhere to many varieties of steel. Ideal for those situations where you need to “Slap On” some heat! Specify when requesting a quote.

Maximum Temperature: 200°F / 93°C

Maximum Watt Density: 1 W/in² (0.16 W/cm²)

Maximum Width: 24" (610 mm)



Flexible Heater Field Applied Adhesive

Field Applied Adhesive

For a field applied permanent bond, a room temperature and ambient humidity curing silicone rubber adhesive is recommended. Tempco offers two types:

Both RTV106 and RTV116 will retain physical and electrical properties up to 500°F (260°C).

When using RTV adhesive, cover the heater completely with a thin layer of RTV, position the heater in place, and use a small roller to remove air bubbles, which could cause hot spots and lead to premature failure of the heater.

RTV106 — a red, paste consistency, high-temperature resistant adhesive sealant.

Part Number: **SEA-102-109** 10.1 ounces
Part Number: **SEA-102-105** 2.8 ounces

RTV116 — a red, pourable, high-temperature resistant adhesive sealant that will flow or self-level on a surface.

Part Number: **SEA-102-102** 9.5 ounces



Flexible Heater Mechanical Fasteners

Various techniques are routinely used when flexible heaters must be detachable from cylindrical parts. The mechanical fastener options include the following:



**Heavy Duty D-Rings
& 3-Layer Straps**



**Standard D-Rings
& 2-Layer Straps**



Velcro® Straps



Boot Hooks & Springs



Boot Hooks & Lacing Cord

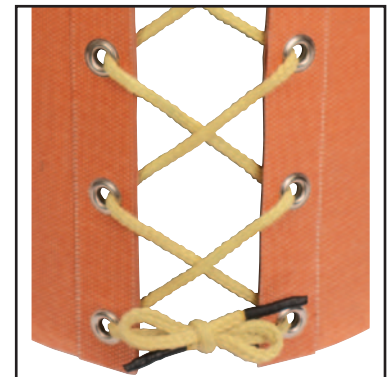

Grommets & Lacing Cord

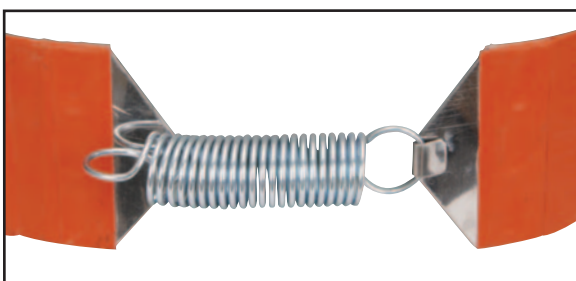

Heavy Duty Spring Clamps



Snaps

Consult Tempco for detailed specifications on the mechanical fasteners shown.

Flexible Heater Clamping

Clamping

Flexible heaters may be applied by clamping or compression between two rigid materials. The plate surfaces must be ground reasonably smooth. Care must be taken not to damage the heater or pierce the insulation. Mill out an area or cutout in the top plate for the added thickness of the lead exit area.

Recommended Maximum Pressure: 40 PSI

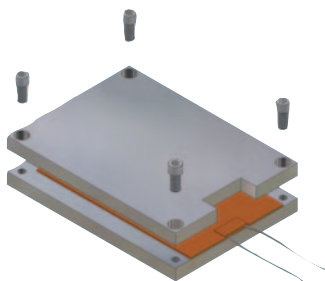

Note: For added durability, mill out the space for the heater to mount in the same thickness as the heater.

Mounting Methods

Outside Diameter Mounting

Tempco has developed the techniques necessary to permanently mount silicone rubber heaters to the outside diameters of pipes and medium size vessels. This technique is particularly useful for heated drums and air or gas heating.

Minimum Diameter: 0.5" (12.7 mm)

Maximum Diameter: 6" (152.4 mm)

Maximum Length: 20" (508.0 mm)

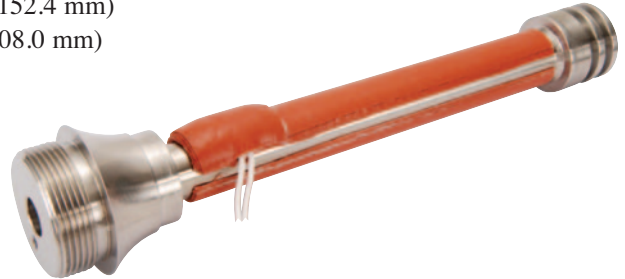

Flexible Heater Three-Dimensional Configurations

Dimensional silicone rubber heaters can be vulcanized to fit a shaped outline. This technique is particularly useful for wrapping Silicone Rubber heaters around pipes or small vessels. Custom tooling or special forms may be required.



7/8" Hexagon

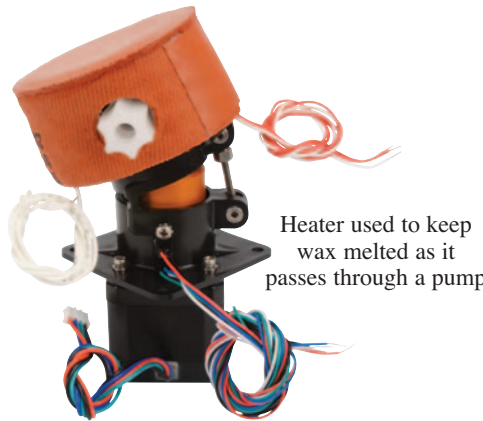

Heater used to keep wax melted as it passes through a pump

An insulating heater used on a compressor pump to prevent freezing in Siberia



One-Piece Y-Pipe Heater
(Shown on Pipe at left;
Shown flat below)



Heater used to remove condensation on a vacuum canister

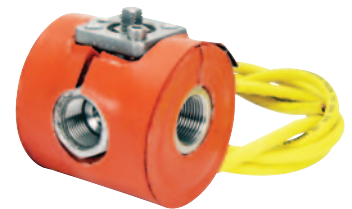

Heater manifold 3D formed for use on a snow making machine

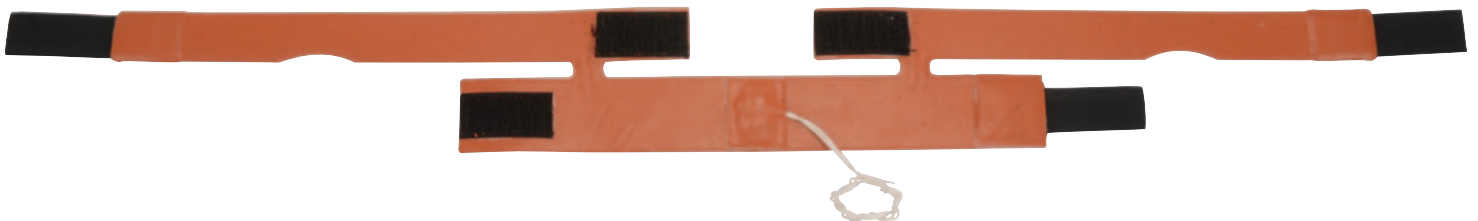

Flexible Heater Built-In Temperature Sensors

Temperature Sensors

Flexible surface heaters can be manufactured with temperature sensors of various types including thermocouples, RTDs, and thermistors. Thermal fuses can also be incorporated into the design to prevent dangerous temperatures in the event of a control device failure (see page 9-17).

The sensors can be mounted on the heater to sense the temperature of the part being heated or the heater surface temperature itself. For silicone rubber heaters, temperature sensors are mounted to the surface of the heater under a vulcanized patch. For Kapton® heaters the sensor is affixed to the surface with epoxy. The leads are run on the exterior of the heater to avoid heat and mechanical interference with the resistance element inside.

Tempco offers three types of sensor mounting:

Heater Sensing: The sensor is located over heater wiring to sense the temperature of the heater surface (standard).

Indirect Load Sensing: A cold section is designed into the resistance element layout for where the sensor is to be located.

Direct Load Sensing (silicone rubber only): A hole/window is cut into the bottom layer of the heater so that the sensor is mounted in the “window” under a vulcanized patch, allowing it to be in contact with the load. (Note: higher cost and subject to potential mechanical damage.)

Lead Wire Connectors

Tempco has the tooling to attach many different types of “quick connectors” that are used with sensors. Consult Tempco with your requirements.

Sensor Types

Thermocouples

Tempco can incorporate common Type J or K thermocouples almost anywhere on the heater surface. Other thermocouple types can also be used. Standard thermocouple temperature ranges apply. Specify when ordering. See page 14-90 for optional plugs.



Note: Standard length is 10". Specify sensor lead wire length and the distance from where the sensor leads exit the heater to the heater edge (Dimension X) when ordering.

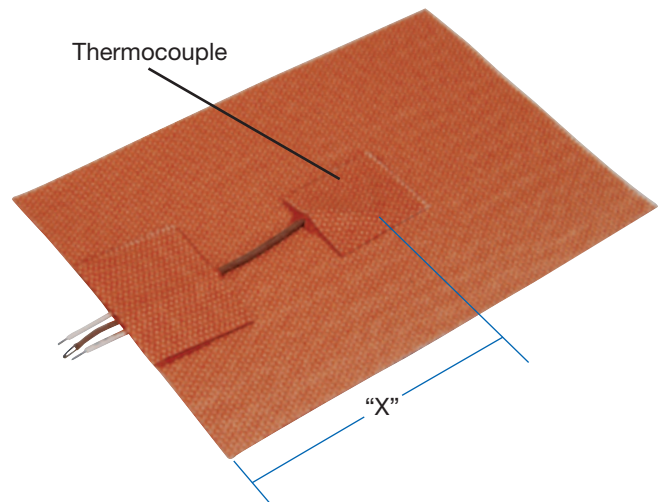

RTDs (2- or 3-wire)

The RTDs used are platinum thin film 100 ohm @ 100°C. The standard curve is 0.00385 TCR / DIN432760. Other common RTDs such as 1000 ohm can also be used. Specify when ordering.

The RTD's resistance increases with a rise in temperature and is considered the most accurate and stable sensor.

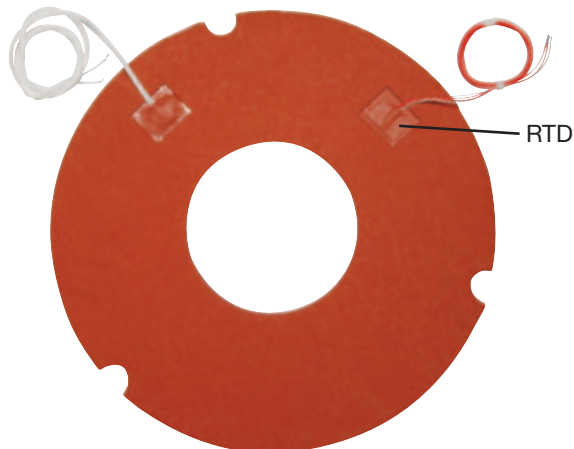

Thermistors

Thermistors are also a resistive-based temperature sensor. They do not generally respond in a linear style and are used in a limited temperature range or at a specific single temperature.

Small bead style thermistors can be mounted directly on the heater.

The thermistor's response is generally designed directly into the customer's electronic control system. Therefore if a thermistor is required, specify manufacturer, specific model number, type and specifications when requesting a quote. Consult Tempco for more information.

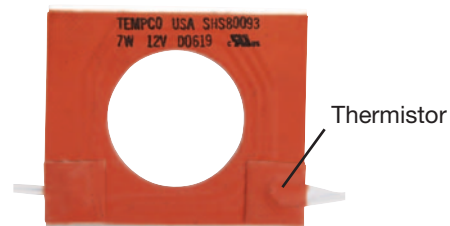

Flexible Heater Built-in Thermostats

Flexible Heater Pre-Set and Adjustable Built-In Thermostats

Pre-set thermostats provide a low-cost means of providing built-in control of surface heaters. The thermostat is normally wired directly into the heater. If the current draw of the heater exceeds the rating of the thermostat, the voltage is over 250V, has a Dual Voltage Design, or is 3-ph, separate leads on the thermostat will be supplied for use with a separate (remote) relay to control the heater (see pages 13-94, 95, 96).

The thermostats are normally mounted over a heated section to sense the heater's temperature or optionally over a cold section to indirectly sense the temperature of the load. The thermostat is enclosed in a molded silicone rubber housing and permanently attached to the heater.

Specify type and location when ordering.



Note: If heater amps exceed thermostat electrical ratings, separate leads will be provided for use with a relay (see pages 13-94 through 13-96).

Snap Action Thermostat – Automatic Reset

Quick cutout on rise to temperature. The contacts will open on rise when the temperature increases to the snap point of the calibrated bimetal disc.

Setpoint (opens): available from 50 to 450°F in 10°F increments
most thermostats close 20 to 30°F below setpoint (see page 13-82)

Electrical Ratings: 125 Vac, 15 Amp, 1875W
250 Vac, 10 Amp, 2500W

Minimum Heater Width: 1.312"

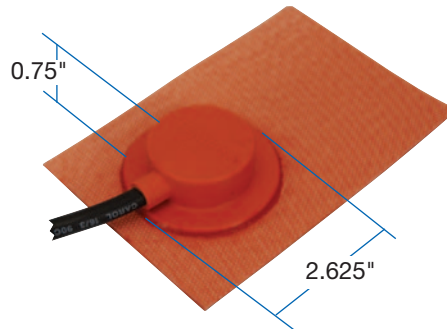
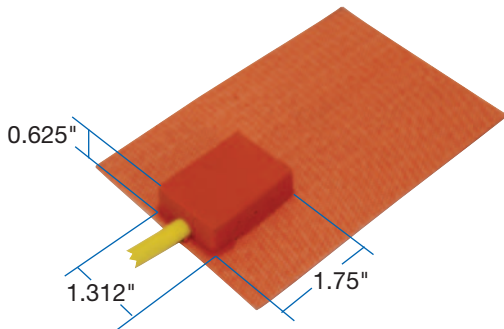
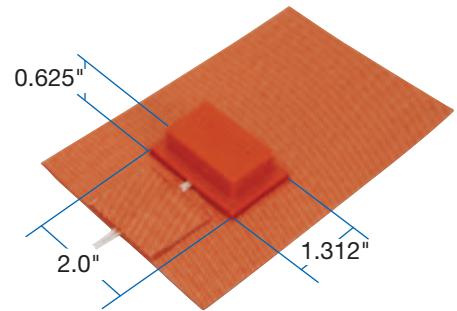

Adjustable Thermostat

Adjustable thermostats allow the user to dial-in a specific temperature and attain a desired result. The thermostat is enclosed in a molded silicone rubber housing and permanently attached to the heater. The adjustment shaft extends through a pre-formed hole. A high temperature knob is included.

Amps: 12.5A @ 125V, 6.5 A @ 250V

Watts: 1500W @ 120V, 1560W @ 240V

Adjustment Ranges Available:

- 50 to 425°F (10 to 218°C)
- 90 to 140°F (32 to 60°C)
- 100 to 190°F (38 to 88°C)
- 70 to 190°F (21 to 88°C)
- 50 to 160°F (10 to 71°C)
- 70 to 140°F (21 to 60°C)

Minimum Heater Width: 1.75" (44.5 mm)

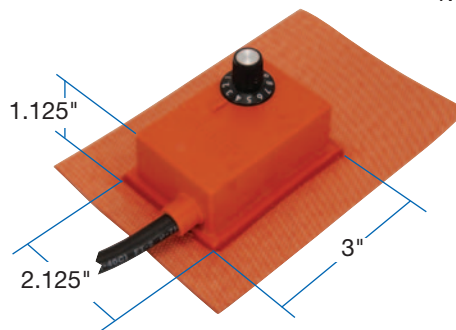
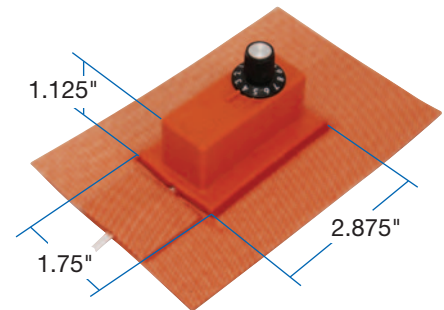

Flexible Heater Built-In Thermostats

Snap Action High Limit Thermostats – Manual Reset

A High Limit with a manual reset push button can also be designed in. Specify when requesting a quote.

NOTE: See page 13-83 for stock temperature ratings.



Creep Action Thermostat

Sustained response, and a slow cutout at the trip point. The creep action thermostat has a slow make/slow break action around setpoint.

Setpoint (opens): available in a limited selection from 50 to 300°F in 10°F increments. Consult Tempco.

Electrical Ratings: 120 Vac, 12 Amp, 1440W
240 Vac, 6 Amp, 1440W

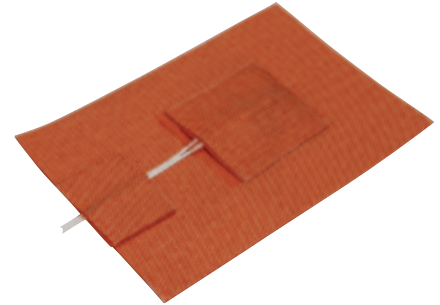

Flexible Heater Built-In Thermal Fusing

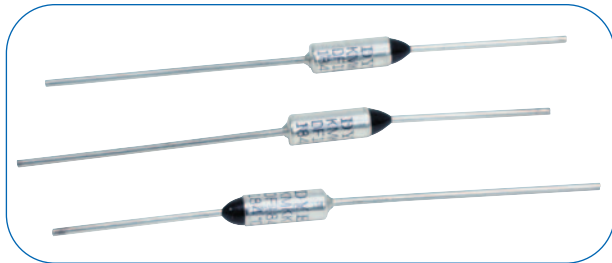

Temperature Range: 151 to 464°F (66 to 240°C)
Single temperature point only, in 10° to 20° steps. Consult Tempco with your requirements.

NOTE: See page 13-84 for stock thermal cutoff temperature ratings.

Thermal fuses / cutoffs are used as high limit protection devices to guard the object being heated from dangerous temperatures in the event of a primary control device failure.

The thermal fuse can be mounted using various methods depending on other options. If the heater does not have a thermostat, the thermal fuse would be mounted under the lead exit patch. If used in conjunction with a thermostat, it could be mounted under the thermostat cover.

Voltage: 120/240 Vac

Maximum Amperage: 10 Amps, continuous



Note: The thermal cutoff is a one-shot, non-resettable component.

PVC Pipe/Conduit Bending Heaters

Tempco's PVC Pipe/Conduit Bending Heater Assembly

makes it easy to form PVC plastic pipe and conduit at the job site. To bend the PVC pipe/conduit, just wrap the heater assembly around the pipe at the location desired and plug it in. In 4 to 18 minutes, depending on pipe size, it will be soft enough to bend by hand to the desired radius or shape.

This heavy-duty assembly, made from our proven wire-wound silicone rubber heater technology, will provide hundreds of hours of use.

Stock PVC Pipe Bending Heaters

Pipe Diameter	Length	Watts	Volts	Warm-Up Time	Part Number
1/2" to 1-1/2"	12"	180	120	4 – 10 minutes	SHS01210
2" to 4"	20"	950	120	7 – 18 minutes	SHS01222

Design Features

- * Built-in thermostat limits temperature to 194°F (90°C)
- * Standard Voltage is 120 Vac
- * 6-ft. plug and cordset standard

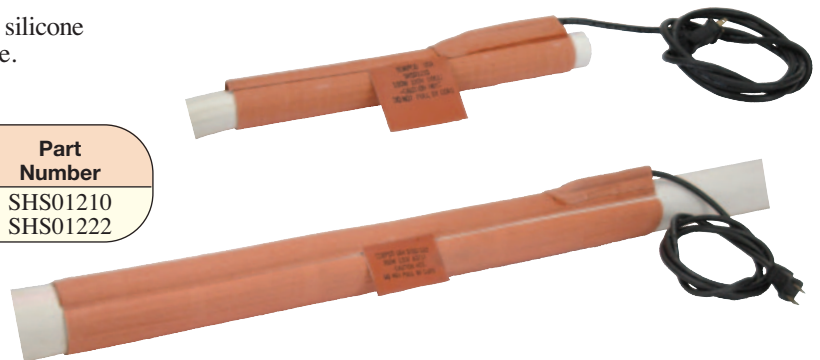

Enclosure Heaters

EHR — Silicone Rubber Enclosure Heater

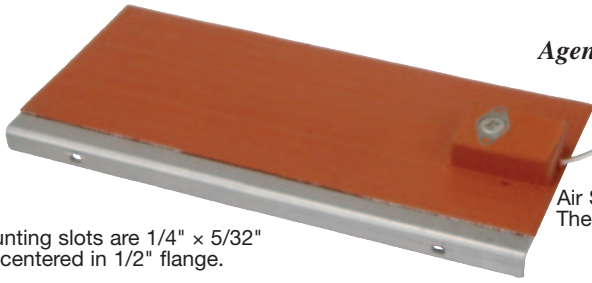

Agency Approval: 

Built-in
Air Sensing
Thermostat



Mounting slots are 1/4" x 5/32"
centered in 1/2" flange.

Standard (Non-Stock) Silicone Rubber Enclosure Heaters

Width	Length	Mounting Center	Watts	Volts	Lead Length	Thermostat (°F)		Part Number
						Opens	Closes	
2½	5	3	25	120	48	—	—	EHR00001
2½	5	3	25	120	48	60	40	EHR00002
2½	5	3	35	120	48	—	—	EHR00003
2½	5	3	50	24	48	—	—	EHR00039
2½	5	3	50	120	48	—	—	EHR00004
2½	5	3	50	120	48	60	40	EHR00005
2½	6	4	60	120	48	—	—	EHR00006
2½	6	4	60	120	48	60	40	EHR00007
2½	6	4	60	120	48	140	110	EHR00008
2½	6	4	60	120	48	180	150	EHR00009
2½	10	7	70	120	48	—	—	EHR00010
2½	10	7	100	12	48	—	—	EHR00049
2½	10	7	100	120	48	—	—	EHR00011
2½	10	7	100	120	48	60	40	EHR00012
2½	10	7	100	230	48	60	40	EHR00028
2½	12	9	80	240	48	60	40	EHR00032
2½	12	9	120	120	48	—	—	EHR00013
2½	12	9	120	120	48	60	40	EHR00014
2½	12	9	120	120	48	140	110	EHR00015
2½	12	9	120	120	48	180	150	EHR00016
2½	12	9	120	240	48	60	40	EHR00034
4½	10	7	140	120	48	—	—	EHR00017
4½	10	7	250	120	48	—	—	EHR00018
4½	10	7	250	120	48	60	40	EHR00019
4½	10	7	250	240	48	140	110	EHR00044

Design Features

- * Available with or without an Integrated Thermostat (See EHA below for Remote Thermostats)
- * Custom Design and Alternate Thermostat Settings Available
- * Heater Vulcanized to an Aluminum Mounting Plate for Easy Installation
- * 120V Standard; Custom Voltages Available upon Request
- * 48" Teflon® Leads Standard
- * Dimensions Listed are for Heater and Bracket; Actual Heater Width is 1/2" Less
- * Safe to Operate, No Exposed Electrical Connections

EHR — Silicone Rubber Heaters are designed for easy installation and safe operation. These rectangular shaped wire-wound Silicone Rubber Heaters are vulcanized to an aluminum mounting plate with mounting holes. They provide superior protection for enclosures of all types against condensation, humidity and freezing.

It is recommended that the enclosure heater be used with a thermostat either built in or mounted remotely to limit the maximum temperature reached and conserve energy. The suggested mounting method is at the bottom of the enclosure, mounted vertically. If a remote mounted thermostat is preferred, mount the heater on the bottom of the enclosure and the thermostat in the middle of the enclosure.

EHA — Remote Thermostats for Enclosure Heaters

Design Features

- * Standard 16ga Teflon® lead length: 48"
- * Can easily be located anywhere in the enclosure using the pressure sensitive adhesive.
- * Any standard thermostat can be used (see page 13-82 for available ranges)
- * Silicone rubber base and enclosure
- * Ratings: 10A/250 Vac, 15A/120 Vac

Pressure Sensitive Adhesive for easy mounting

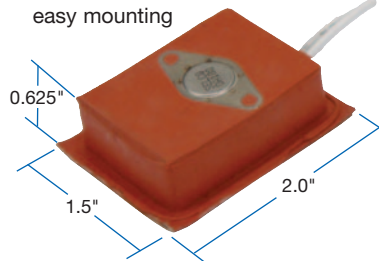

EHA00005 D-ring and strap mounting thermostat. Can be applied to sense the air around an object or an object directly.



Ordering Information

Select a **Remote Thermostat** from the list at right.

Custom Engineered/Manufactured Remote Thermostats

Standard lead time is 3 weeks. Please Specify the following:

- ❑ **Range:** Select from the list of thermostats on page 13-82
- ❑ **Lead Length:** Specify any special lead length you require.

Stock EHA Remote Thermostats

Opens °F	Closes °F	Part Number	
		PSA	D-ring & Strap
60±5	40±7	EHA00001	EHA00005
140±5	110±10	EHA00002	—
180±5	150±10	EHA00003	—

⚠ WARNING: Cancer and Reproductive Harm - www.P65Warnings.ca.gov.

Composite Curing Flexible Heater Blankets

Specialized Silicone Rubber Heater Blankets are used in the composite industry to bond and cure composite structures using vacuum bagging techniques which have become standard in the industry.

Tempco's composite bonding and curing heater blankets are designed with the field technician in mind with an extra strong strain relief, and even heat distribution to produce the best possible cure or bond.

Temperature uniformity is optimized for even heating through computer designed resistance elements. Circuit spacing is maintained at 1/4" for larger heater blankets or less on smaller heaters. This technique guarantees a $\pm 10^{\circ}\text{F}$ ($\pm 5.5^{\circ}\text{C}$) temperature uniformity across the heater blanket.

The lead wires exit the heater through an unheated 2" x 2" lead exit tab. This allows the overall heater surface to be heated while maintaining a separate unheated section for the transition from resistance element to the leads and a solid strain relief.

Tempco's Composite Curing Heater Blankets emphasize strength, durability, flexibility and overall temperature uniformity.

Design Features

- * **Maximum Temperature:** 500°F/260°C intermittent
450°F/232°C continuous
- * **Material:** Fiberglass reinforced Silicone Rubber
- * **Smooth bottom layer for contact with the composite under cure**
- * **External Lead Exit Tab, 2" x 2"** maximizes heating area and uniformity
- * **Lead wire:** Teflon®, 5-ft. length, 400°F/200°C, 600V
- * **Composite Industry Watt Density Standard of 5 watts/in²**
- * **Available Voltage:** 120 Vac or 240 Vac
- * **Meets Composite Industry uniformity standard of $\pm 10^{\circ}\text{F}$**
- * **Each heater blanket has a serial number for traceability**
- * **Heat Mapping Certification available**
- * **Made to Order:**
Maximum Width: 36" (914mm)
Maximum Length: 120" (3048mm)
Maximum Diameter: 32" (813mm)
- * **UL recognized**

Standard (Non-Stock) Round Flexible Heater Blankets

Diameter		Watts	Voltage	
inches	mm		120	240
6	152	170	SHS89041	SHS89044
10	254	470	SHS89042	SHS89045
15	381	1055	SHS89043	SHS89046



Note: Round heaters have a higher watt density than listed rectangular sizes, and provide an additional 20% of surface heat.

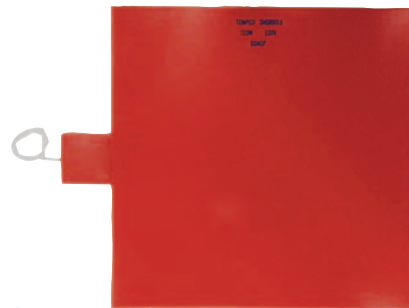

Typical Applications

- ➔ **Aerospace/Aircraft**
 - Repair
 - Manufacturing
- ➔ **Marine/Boats**
 - Repair
 - Manufacturing
- ➔ **All composite, metal bonding, curing applications**

Thermal Mapping

It is a known fact in the composite repair industry that the quality of the overall repair often relates directly to the quality of the cure. The cure in turn is directly affected by the temperature uniformity of the heat blanket.

Thermal/heat mapping certification of the heater blanket is rapidly becoming the standard operating procedure for many repair facilities to optimize the cure process.

As an added value service, Tempco can certify that the heat blanket you order follows the guidelines established by the Commercial Aircraft Composite Repair Committee (CACRC), SAE document ARP 5144 Section 7, which states specific recommendations for the "...handling, maintenance and thermal testing of heat blankets..." The heater blanket certification also meets the requirements of Boeing document D6-56 273 "Qualification of Heat Blankets for Hot Bonding Composites."

Standard (Non-Stock) Flexible Heater Blankets

inches		mm		Watts	Voltage	
L	W	L	W		120	240
4	10	102	254	200	SHS89001	SHS89021
6	6	152	152	180	SHS89002	SHS89022
6	8	152	203	240	SHS89003	SHS89023
6	10	152	254	300	SHS89004	SHS89024
6	20	152	508	600	SHS89005	SHS89025
6	24	152	610	720	SHS89006	SHS89026
6	36	152	914	1080	SHS89007	SHS89027
8	8	203	203	320	SHS89008	SHS89028
8	12	203	305	480	SHS89009	SHS89029
10	10	254	254	500	SHS89010	SHS89030
10	12	254	305	600	SHS89011	SHS89031
10	18	254	457	900	SHS89012	SHS89032
12	12	305	305	720	SHS89013	SHS89033
12	18	305	457	1080	SHS89014	SHS89034
12	24	305	610	1440	SHS89015	SHS89035
15	15	381	381	1125	SHS89016	SHS89036
15	18	381	457	1350	SHS89017	SHS89037
18	18	457	457	1620	SHS89018	SHS89038
18	24	457	610	2160	SHS89019	SHS89039
24	24	610	610	2880	SHS89020	SHS89040

Flexible Heaters



Silicone Rubber Drum Heaters

Silicone Rubber Drum and Pail Heaters

Design Features

- * Maximum operating temperature of 425°F (218°C).
- * Power cord is 6-foot long, SJO Type 16/3 complete with three-prong plug for 120 VAC models. Plugs are not included on 240 VAC models but are available (see page 15-15).
- * Surface grounded electrically with internal ground screen.
- * 1250 volts dielectric tested.
- * Vulcanized silicone rubber construction resistant to moisture, ozone, fungus, and radiation.
- * Adjustable thermostat, see page 9-16 for specifications.

- Built tough
- Resistant to chemicals
- Ratings for Metal and Plastic Drums and Pails
- Easy to clean
- Stock to 2-week lead time

Agency Approval:
(See page 9-2 for details) 



Tempco flexible drum heaters can save time by heating stored viscous fluid to a pourable temperature.

The heater is built to be tough, long lasting, and resistant to chemicals. Because few materials stick to its silicone rubber with fiberglass reinforced construction, it is easy to clean. The heater comes with a 6-foot cord and plug (120V only). When not in use, it rolls for convenient storage.

The total wattage (number of heaters) and the material being heated inside of the drum must be considered when determining the actual temperature to which that specific material can be heated.

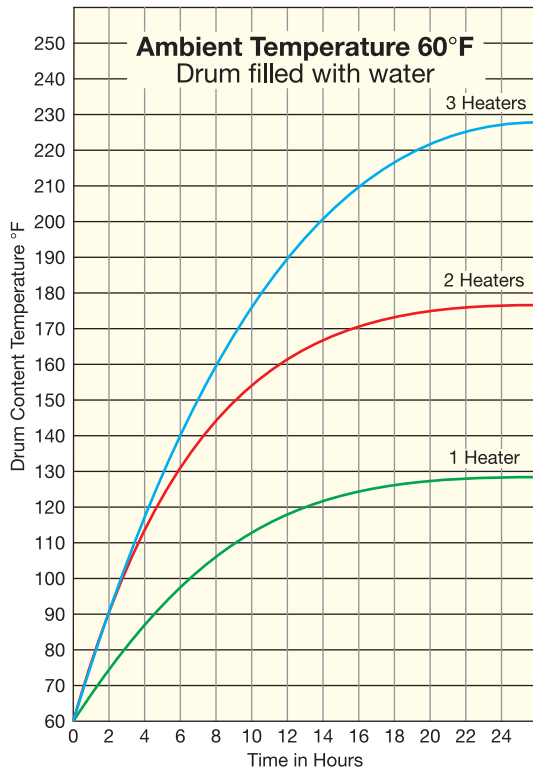

Note: Metal Jacketed Drum Heaters and heated Drum Dollies can be found on page 11-122, Drum Immersion Heaters on page 11-123, and Drum Blanket Heaters on page 11-124.

Standard (Non-Stock) and Stock Drum Heaters for Metal Drums

Stock Items Are Shown In **RED**

Drum Size	Drum Dia.	Heater Width	Heater Length	Watts	Part Number		Thermostat
					120V	240V	
5 Gal.	11.5	3"	31"	300	DHR00150	DHR01010	50-425°F
15 Gal.	13.5	3"	38"	500	DHR00110	DHR00130	50-425°F
30 Gal.	18	3"	52"	750	DHR00070	DHR00090	50-425°F
55 Gal.	22.5	3"	64"	1000	DHR00020	DHR00040	50-425°F
5 Gal.	11.5	3"	31"	300	DHR00140	DHR01041	No
15 Gal.	13.5	3"	38"	500	DHR00100	DHR00120	No
30 Gal.	18	3"	52"	750	DHR00060	DHR00080	No
55 Gal.	22.5	3"	64"	1000	DHR00010	DHR00030	No
5 Gal.	11.5	4"	31"	550	DHR01014	DHR01018	50-425°F
15 Gal.	13.5	4"	38"	700	DHR01013	DHR01017	50-425°F
30 Gal.	18	4"	52"	1000	DHR01012	DHR01016	50-425°F
55 Gal.	22.5	4"	64"	1500	DHR00050	DHR00055	50-425°F
5 Gal.	11.5	9.5"	31"	1000	DHR01023	DHR01047	70-190°F
15 Gal.	13.5	9.5"	38"	1000	DHR01024	DHR01046	70-190°F
55 Gal.	22.5	9.5"	64"	1500	DHR01025	DHR01045	70-190°F

Standard (Non-Stock) and Stock Drum Heaters for Plastic Pails

Stock Items Are Shown In **RED**

Drum Size	Drum Dia.	Heater Width	Heater Length	Watts	Part Number		Thermostat
					120V	240V	
5 Gal.	11.5	4"	31"	150	DHR01034	DHR01044	50-160°F
15 Gal.	13.5	4"	38"	200	DHR01035	DHR01036	50-160°F
30 Gal.	18	4"	52"	250	DHR01037	DHR01038	50-160°F
55 Gal.	22.5	4"	64"	300	DHR01033	DHR01039	50-160°F
5 Gal.	11.5	9.5"	31"	300	DHR01027	DHR01043	70-140°F
55 Gal.	22.5	9.5"	64"	750	DHR01026	DHR01042	70-140°F

Standard lead time is Stock to 2 weeks.

View Product Inventory @ www.tempco.com

Hazardous Area Rated Silicone Rubber Drum Heaters



Design Features

- * Dual setpoint NEMA 7 temperature controller connected to a high temperature limit indicator light
- * Extra wide 8" coverage area
- * Exceptional durability and flexibility
- * Grounded heating element meets NEC 427.23
- * Designed for metal drums



Hazardous Area Rated

Class I Division 2:
Groups A, B, C and D

Class II Division 2:
Groups F and G

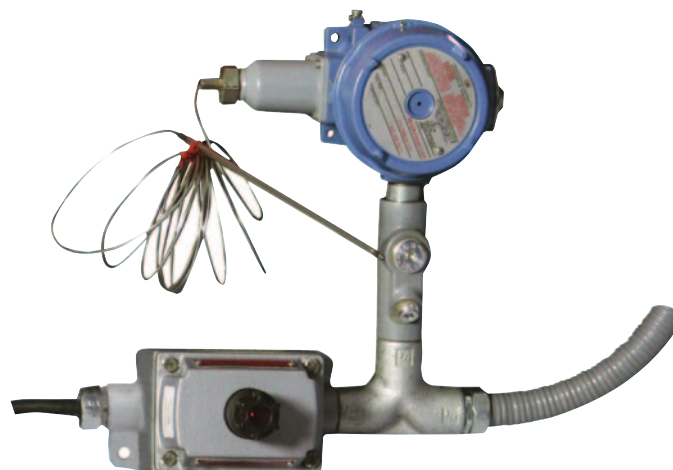

NEMA 7 Thermostat Control Assembly with High Limit Indicator Lamp

Specifications

Physical Description

Heating element is laminated between two layers of 23 mil and two layers of 25 mil fiberglass reinforced silicone rubber.

Power Density: 2.5W/sq.in.

Nominal Silicone Rubber Density: 26 oz/sq.yd.

Electrical Ratings

Wiring from Drum Heater to Controller: 6 ft. liquid-tight conduit

Line Cord from Controller Assembly: 6 ft. industrial power cord

Line Cord Termination: 120V – Hazardous area rated 5-15P plug
240V – No plug, flying leads

Thermostat

High Limit Thermostat:

- Designed to keep blanket below NEC article 500-T rating:

T Rating	NEC Temperature	Actual High Limit
T3	392°F (200°C)	292°F (145°C)
T4A	248°F (120°C)	158°F (70°C)

- High limit red indicator lamp
- Attached adjustable dual setpoint thermostat NEMA 7 temperature controller. Moisture and chemical resistant.

Thermostat Range: 25°-325°F/-4°-163°C, dual scale limited by the "T Rating"

Ordering Information

Select the part number of the hazardous area silicone rubber drum heater that matches your requirements.

Standard lead time is 4 weeks.

Standard Hazardous Area Rated Drum Heaters

Drum Size Gallons	Drum Dia. in.	Heater Width in.	Heater Length in.	Wattage	Part Number		T-Rating
					120VAC	240VAC	
30	18.6	8	58.5	1000	DHX00101	DHX00201	T-3
55	22.3	8	70.0	1300	DHX00102	DHX00202	T-3
30	18.6	8	58.5	1000	DHX00103	DHX00203	T-4A
55	22.3	8	70.0	1300	DHX00104	DHX00204	T-4A

⚠ WARNING: Cancer and Reproductive Harm - www.P65Warnings.ca.gov.



Quote Request

Flexible Heater Quote Request

Made-To-Order Quote Request Form — Copy and Fax (630-350-0232) Us Your Requirements

Customer Drawing

Name _____
Company _____
Address _____
Phone _____ Fax _____
E-mail _____

Application Information

Describe in Detail _____

Maximum Load Temperature _____
Ambient Temperature _____
Quantity _____

Specifications

Insulation Material: Silicone Rubber _____ Kapton® _____
Resistance Style: Wire _____ Foil _____ Thk. Film _____
Length _____ Width _____ Diameter _____
Watts _____ Volts _____
UL _____ cUL _____ CSA _____
Lead Length (10" standard) _____
Insulation (Teflon® standard) _____
Lead Location (indicate code from page 9-9 & on sketch) _____
Options (holes, cutouts, etc. - describe & indicate on sketch) _____

Maximum Thickness _____
(if applicable, except for lead exit)

Notes _____

Controls and Sensors

Thermostat: Pre-set Type _____
Temperature Setting (opens) _____
Adjustable (range 50-450°F) _____
Mounting: Heater Sensing (standard) _____
Load Sensing _____
Location (describe & indicate on sketch) _____

Thermocouple: Type (J, K or other) _____
RTD (DIN 100 ohm) _____ Other _____
Thermistor (indicate manufacturer part #, calibration curve/spec & useful range) _____

Sensor Mounting:
Heater Sensing (standard) _____
Load Sensing _____
Location (describe & indicate on sketch) _____

Sensor Lead Length (10" standard) _____
Sensor Insulation (Teflon® standard) _____ Fiberglass _____
Options _____

Mounting

None _____
Pressure Sensitive Adhesive (PSA) _____
Boot Hooks & Springs _____ Quantity _____
Eyelets/Grommets _____ Quantity _____
Lacing Cord _____ Length _____
Straps & Velcro _____ Strap Length _____ Quantity _____
Straps & D-Rings _____ Strap Length _____ Quantity _____
Factory Vulcanizing _____ Description _____

Sponge Insulation _____ Thickness _____
Describe in Detail _____

⚠ WARNING: Cancer and Reproductive Harm - www.P65Warnings.ca.gov.

View Product Inventory @ www.tempco.com

Adhesive Backed Heating Tape

Electrical Resistance Heating Tape — Adhesive Backed

Designed For High Heat Transfer

All electrical resistance elements create heat, but some systems are better at transferring this energy. The secret to this heating tape is in its thermally conductive adhesive and its outer reflective sheath.

The adhesive surrounds the resistance wire and transfers the thermal energy directly to the surface of the load. The resistance wire itself has a back and forth kink that acts as a spring to absorb expansion and contraction.

The outer aluminum sheath spreads heat evenly over the entire surface of the tape and also reflects heat back onto the load.

The end result is a highly efficient heating source with maximum heat being transferred to the desired material.

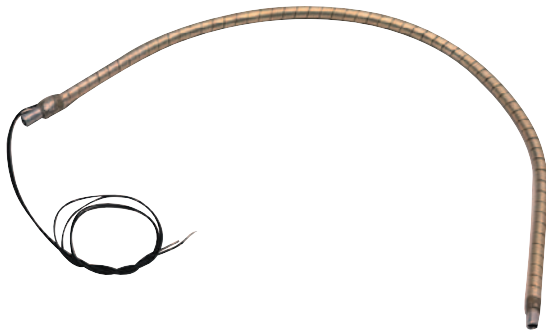

Typical finished assembly with leads.

ADHESIVE SPECIFICATIONS

	Silicone	Acrylic
Operating Temperature Range	-100°C to 250°C -148°F to 482°F	-100°C to 180°C -148°F to 356°F
Outgassing... TML/VCM	1.047%/.322%	.264%/.000%
Adhesion to Etched Aluminum (oz/inch width)	28 @ +125°C 450 @ -100°C	29 @ +125°C 50 @ -100°C
Overall Thickness Applied	.025" (.63 mm)	.028" (.71 mm)
Dielectric Strength	600 Vdc	600 Vdc

Typical Applications

- ➔ Cylinder wrap ideal for tubes, pipes or vessels.
- ➔ Placed directly on PVC, PTFE plastic pipe without the need for other material.
- ➔ Excellent for prototype engineering, placing heat exactly where it is needed.
- ➔ Even heating throughout the length of a heated hose for hot wax handling, food processing, hot melt and other plastic processing.
- ➔ De-fogging, de-icing, fuel line warming.
- ➔ Acrylic product approved by NASA for space flight.
- ➔ Acrylic low outgassing perfect for vacuum applications.

Product Types

4 Conductor Tape 1/2" (12.7 mm) wide; has the highest watt density and the most variety of resistances. It can have leads at one end in the case of a series connection or a series/parallel connection, or leads at either end in a parallel connection.

The tightest wrap this tape can achieve is on a 1/4" (6.3 mm) O.D. surface. A smaller tube should be wrapped with 1/4" (6.3 mm) or 1/6" (4.2 mm) tape.

2 Conductor Tape 1/4" (6.3 mm) wide; has leads on one end in the series connection, and leads at both ends for parallel connections. This tape will wrap down to 1/8" (3.17 mm) O.D.

1 Conductor Tape 1/6" (4.2 mm) wide; can wrap down to .060" (1.52 mm) O.D. A lead will be present at both ends.

General Purpose Wattage Calculations for Tube and Pipe Heating

$$T_p = P \times L \times \Delta T$$

T_p = Total Watts Required

P = Watts per lineal foot of tube per °F temp. rise (see chart below)

L = Length of tube in feet

ΔT = Temperature rise, °F above ambient

To Find P: Look at the intersection of Tube O.D. and Insulation thickness.

Insulation Thickness	Tube Outside Diameter			
	1/4"	1/2"	1"	2"
Bare	.10	.13	.21	.40
1/2"	.07	.09	.13	.20
1"	—	.05	.08	.11



Note: This is for estimating power requirements only. Confirmation by prototype testing is recommended.

- If the temperature rise is over 100 degrees, increase the wattage by 10%.
- For rapid start-up and to allow for colder material entering the hose, increase the wattage by 25% and use a temperature controller with a temperature sensor.

Warning !! FTP Heat Tape is essentially resistance wire in a mountable high temperature adhesive backed tape. In order to be used properly, the heater design must be done and the math worked out, following the example provided.

Electrical Resistance Heating Tape — Adhesive Backed

Engineering Example

A 10 ft. stainless steel braided hose, 1/2" O.D., needs to be heated to 400°F from 70°F. Insulation: 1/2". The voltage is 220V.

- Determine the Length.** To cover the hose completely would take $\pi \times 1/2" \times 120" = 188$ sq. in. A 12" length of 1/2" tape would cover 6 sq. in. of hose; therefore, 31 ft. of 1/2" tape would completely cover the hose, spiral wrapped edge to edge.
- Determine the Watts.** Total Power (Tp) = P × L × ΔT
From the chart, P = .09 for a 1/2" hose with 1/2" insulation, therefore
Tp = .09 × 10 ft. × (400-70) = 297 Watts. For rapid start-up and to compensate for colder material flowing through the hose, increase the wattage by 25% to 400W.
- Calculate the Ohms per Foot.** The ohms/ft. = E² ÷ (Tp × L)
Therefore ohms/ft. = 220² ÷ (400W × 31 ft.) = 3.9 ohms per ft.
- Calculate the Watts per Foot.** The Watts per ft. = Tp ÷ L
Therefore the watts/ft. = 400 watts ÷ 31 ft. = 12.9 watts/ft.
- Choose Heat Tape Material from the Table.** From the table, the FTP00035, 1/2" tape with four conductors and silicone adhesive in the parallel/series connection at 4.0 ohm/ft. would fill the requirements. The required 12.9 watts/ft. is well under the maximum rating of 62 watts/ft.



Bulk roll of Heat Tape

CHART NOTES

Resistance Wiring

Type 1. Ohms per foot, with all conductors in a *Parallel Connection*.

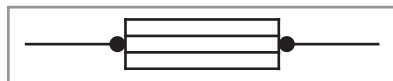

Type 2. Ohms per foot, with all conductors in a *Series Connection*.

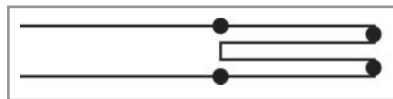

Type 3. Ohms per foot, with all conductors in a *Parallel - Series Pair Connection*.

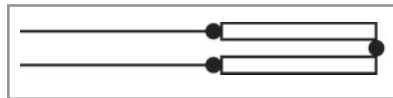

Max. Watts/ft. in Ohms-Per-Foot Table

The maximum wattage per lineal foot is when the heat tape is applied to a metal heat sink at room temperature. Reduce these ratings linearly to zero watts output at 500°F. Adhesion to heat sink along entire length is important to prevent burnout when tape is used near maximum wattage rating.

Example: A tape that is 70W/ft. maximum watt density at 74°F, would derate to about 35W/ft. maximum watt density at 250°F.

Heating Tape — Ohms-Per-Foot Table

Width		1/8" (4.2 mm)		1/4" (6.3 mm)		1/2" (12.7 mm)					
Number of Conductors		1 conductor		2 conductors		4 conductors					
Part Number		Max.		Ohms/ft. see notes		Max.		Ohms/ft. see notes		Max.	
50 ft. roll	100 ft. roll	Ohms/ft.	Watts/ft.	(1)	(2)	Watts/ft.	(1)	(3)	(2)	Watts/ft.	(4)
FTP0001	FTP1001	1.9	25	.9	3.8	40	.5	1.9	7.6	70	
FTP0002	FTP1002	3.2	25	1.6	6.4	40	.8	3.2	12.8	70	
FTP0003	FTP1003	4.0	23	2.0	8.0	35	1.0	4.0	16.0	62	
FTP0004	FTP1004	4.9	20	2.4	9.8	30	1.2	4.9	19.6	52	
FTP0005	FTP1005	7.0	25	3.5	14.0	40	1.7	7.0	28.0	70	
FTP0006	FTP1006	8.8	23	4.4	17.6	35	2.2	8.8	35.2	62	
FTP0007	FTP1007	10.8	20	5.4	21.6	30	2.7	10.8	43.2	52	
FTP0008	FTP1008	13.2	20	6.6	26.4	30	3.3	13.2	52.8	52	
FTP0009	FTP1009	21.3	13	10.6	42.6	20	5.3	21.3	85.2	32	
FTP0010	FTP1010	26.8	10	13.4	53.6	16	6.7	26.8	107.2	25	

Accessories

	16-20 Ga.	22-26 Ga.
Terminal Kit for 1-wire	FTP00911	FTP00913
2-wire	FTP00912	FTP00914
Additional solderless crimps	FTP00920	FTP00921
Aluminum/Silicone Heat Transfer Tape	3/4" × 27 ft. FTP00930	1-1/4" × 27 ft. FTP00931

Terminal kits are required to terminate the bulk tape into a finished heater assembly. To determine 1-wire or 2-wire, refer to the number of wires being terminated at the end of the heater. For example, to complete the heater in a parallel connection, two 1-wire terminal kits would be required because one lead exits from each end of the heater assembly. The "solderless crimps" are used to complete the non-lead end of the heater. The Heat Transfer Tape is used to provide additional adhesion, placed over the heating tape.

Ordering Information — Bulk Heat Tape

Heat Tape can be ordered in **bulk in 50 or 100 ft. rolls** or in custom assemblies. The part number for each item is completed by filling in the with a number from the following table to detail adhesive type and tape width:

- | | | |
|---------------------------------|---------------------------------|---------------------------------|
| 1—silicone, 1/6" wide (1 cond.) | 2—acrylic, 1/6" wide (1 cond.) | 3—silicone, 1/4" wide (2 cond.) |
| 4—acrylic, 1/4" wide (2 cond.) | 5—silicone, 1/2" wide (4 cond.) | 6—acrylic, 1/2" wide (4 cond.) |

Custom Engineered/Manufactured Heaters

For a quote, **Please Specify** the following

- Application Information Wattage Requirements Lead Information:

⚠ WARNING: Cancer and Reproductive Harm - www.P65Warnings.ca.gov.

High Temperature Heating Tape

Flexible Heating Tape — Duo-Tape®

Design Features:

- * 1400°F (760°C) temperature rating
- * 2 ft. (610 mm) long high temperature lead wires on one end
- * Highly flexible & rugged, knitted design
- * High, medium and low watt density designs
- * Constant wattage (min. ohm change cold to hot)

Typical Applications:

- ➔ Laboratory, general application
- ➔ Research and Development
- ➔ Pilot plant research heaters
- ➔ High temperature hose heating
- ➔ Industrial applications, anywhere high temperature and flexibility are required (non-hazardous and dry locations only)

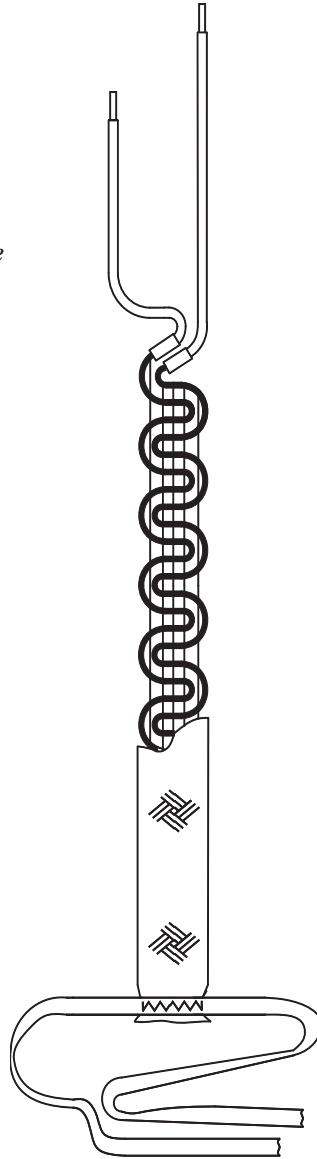

OPTIONS

- 1. Plug** A 120V plug can be ordered on indicated heaters only as a custom assembly. Since the leads of the Duo-Tape are on one end, the plug is a single molded unit.
- 2. Lead Wire** Standard lead wire length is 2 ft. (61 cm)



Note: When a plug is requested, lead wire length may be 2 ft. or shorter. Optional lengths may be ordered to 8 ft. For special length, width, watts or volts—contact **Tempco**.

Tempco Heating Tapes

We provide high temperature, flexible electric heating elements. They were developed to offer the unique convenience of wrap-on heat for tubing, laboratory apparatus or any dry environment application where flexible surface spot heat is required.

Heating tapes are offered in many standard sizes, having watt densities from 3.25 to 13 watts per square inch, and temperature ratings to 1400°F (760°C).

CONSTRUCTION

The construction begins with bundled, fine strand resistance wire, 37 to 40 gauge, covered with a minimum of 2 layers of high temperature braided AMOX yarn. The insulated resistance wire is then knitted into a serpentine configuration, forming a flat tape. Once the lead wires are attached, most tapes have an additional braided, dielectric protection layer of AMOX yarn for use on conductive (metal) surfaces.

DURABILITY FEATURE

Unlike other straight element heating wires and tapes, knitting allows for cushioning during heating and cooling. The element expands in all directions rather than one, virtually eliminating “thermal growth.” In addition, knitting prevents the tape from tensile stress when stretched (a typical problem of elements applied to flexible hoses).

LOW WATT DENSITY, WELL DISTRIBUTED HEAT FEATURE

Knitting allows dense distribution of wire per unit length of tape. This feature provides longer life resulting from lower watts per inch of wire. (A typical 1 inch wide tape may contain 10 inches (25.4 cm) of wire element.)

DUO-TAPE

Duo-Tape is a breakthrough design innovation that allows two wires to be knitted side by side. The advantage is that the lead wires may be attached on the same end rather than opposite ends. The balance of the tape is constructed the same as the other single wire tapes.

Flexible Heating Tape — Duo-Tape®

Duo-Tape Standard (Non-Stock) Sizes and Ratings

Part Numbers in table are for heaters without plugs.
Plugs are available for 120V heaters only.

Watt Density	Size	Watts	Part Number	
			120V	240V
13.00 W/in ²	½" × 2'	156	FTF00101	FTF00107
	½" × 4'	312	FTF00102	FTF00108
	½" × 6'	468	FTF00103	FTF00109
	½" × 8'	624	FTF00104	FTF00110
2.0 W/cm ²	½" × 10'	780	—	FTF00111
	½" × 12'	936	—	FTF00112
	½" × 16'	1248	—	FTF00113
	1" × 2'	312	FTF00105	FTF00114
	1" × 4'	624	FTF00106	FTF00115
	1" × 6'	936	—	FTF00116
	1" × 8'	1248	—	FTF00117
	8.67 W/in ²	½" × 2'	104	FTF00118
½" × 4'		208	FTF00119	FTF00125
½" × 6'		312	FTF00120	FTF00126
½" × 8'		416	FTF00121	FTF00127
½" × 10'		520	FTF00122	FTF00128
½" × 12'		624	—	FTF00129
½" × 16'		832	—	FTF00130
1" × 2'		208	FTF00123	FTF00131
1" × 4'		416	FTF00124	FTF00132
1" × 6'		624	—	FTF00133
1" × 8'		832	—	FTF00134
1" × 10'		986	—	FTF00135
3.25 W/in ²	½" × 2'	39	FTF00136	—
	½" × 4'	78	FTF00137	FTF00147
	½" × 6'	117	FTF00138	FTF00148
	½" × 8'	156	FTF00139	FTF00149
	½" × 10'	195	FTF00140	FTF00150
	½" × 12'	234	FTF00141	FTF00151
	½" × 16'	312	FTF00142	FTF00152
	1" × 2'	78	FTF00143	FTF00153
	1" × 4'	156	FTF00144	FTF00154
	1" × 6'	234	FTF00145	FTF00155
	1" × 8'	312	FTF00146	FTF00156
	1" × 10'	385	—	FTF00157
	1" × 12'	468	—	FTF00158
	1" × 16'	624	—	FTF00159



Flexible Heating Tape Duo-Tape



Typical Duo-Tape assembly including ties

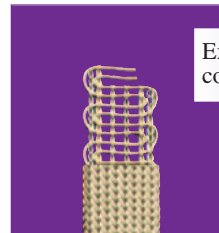

Example of internal construction before covering

Ordering Information

Standard Heaters

Choose the Duo-Tape Heater from the above table that meets your needs. Specify Part Number.

Custom Engineered/Manufactured Heaters

An electric heater can be very application specific; for sizes and ratings not listed, **Tempco** will design and manufacture a Duo-Tape Heater to meet your requirements. **Standard lead time is 2 to 3 weeks.**

Please Specify the following:

- Application
- Length
- Wattage
- Voltage
- Termination
- Leads
- Crimp Connectors

⚠ WARNING: Cancer and Reproductive Harm - www.P65Warnings.ca.gov.

Duo-Tape® — Silicone Rubber Insulated Flexible Heating Tapes

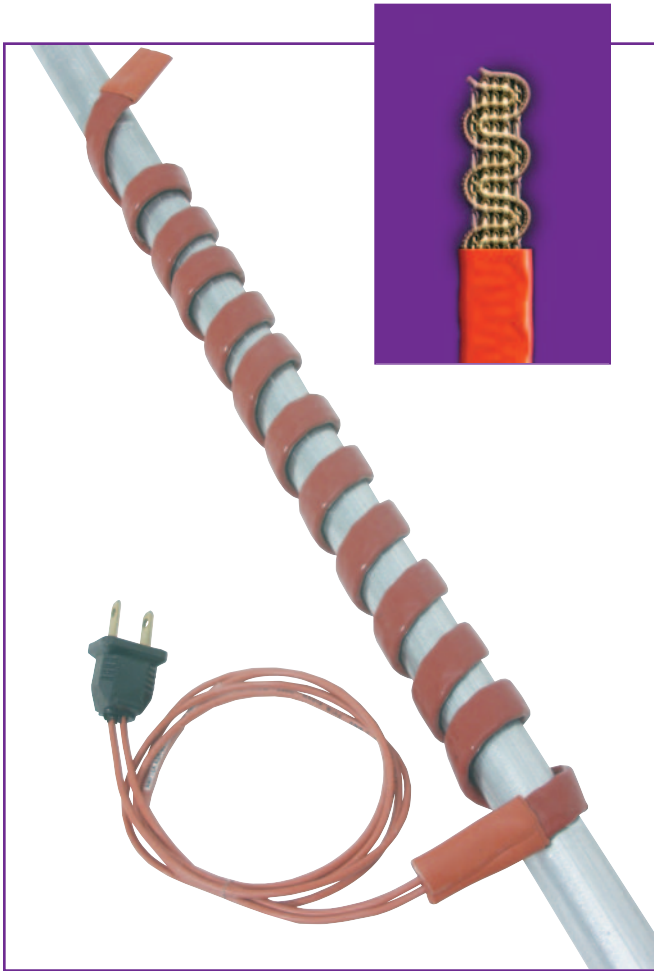

The same proven internal design of all Duo-Tapes of knitted Amox yarn over serpentine resistance is used. The heavy silicone rubber extruded outer cover provides abrasion and dielectric protection for the heating element.

Silicone Rubber Duo-Tapes may be used on conductive surfaces, and in applications where moisture, chemical and abrasion resistance is required.

Design Features:

- * 400°F (204°C) temperature rating, non-energized exposure to 500°F (260°C)
- * 2 ft. (610 mm), 16 gauge, 600 VAC silicone rubber insulated leads
- * Vulcanized fiber reinforced silicone rubber end cap
- * Standard low watt density of 4.3 w/inch²
- * All standard 120 Volt units are provided with plug
- * Multi strand wire element for maximum flexibility
- * Highly flexible and durable design

Standard Sizes — with 2 ft. leads, 120V only with plug

Watt Density	Size		Watts	Part Number	
	US	Metric(CM)		120V	240V
4.3 W/in ²	.5" × 2 ft.	1.3 × 60	52	FTF20001	—
	.5" × 4 ft.	1.3 × 120	104	FTF20002	FTF20022
	.5" × 6 ft.	1.3 × 180	156	FTF20003	FTF20023
	.5" × 8 ft.	1.3 × 240	208	FTF20004	FTF20024
	.5" × 10 ft.	1.3 × 300	260	FTF20005	FTF20025
	.5" × 12 ft.	1.3 × 360	312	FTF20006	FTF20026
	.5" × 14 ft.	1.3 × 420	364	FTF20007	FTF20027
	.5" × 16 ft.	1.3 × 480	416	FTF20008	FTF20028
	.5" × 18 ft.	1.3 × 540	468	FTF20009	FTF20029
	.5" × 20 ft.	1.3 × 600	520	FTF20010	FTF20030
0.67 W/cm ²	.5" × 24 ft.	1.3 × 720	624	FTF20011	FTF20031
	1" × 2 ft.	2.5 × 060	104	FTF20012	FTF20032
	1" × 4 ft.	2.5 × 120	208	FTF20013	FTF20033
	1" × 6 ft.	2.5 × 180	312	FTF20014	FTF20034
	1" × 8 ft.	2.5 × 240	416	FTF20015	FTF20035
	1" × 10 ft.	2.5 × 300	520	FTF20016	FTF20036
	1" × 12 ft.	2.5 × 360	624	FTF20017	FTF20037
	1" × 14 ft.	2.5 × 420	728	FTF20018	FTF20038
	1" × 16 ft.	2.5 × 480	832	FTF20019	FTF20039
	1" × 18 ft.	2.5 × 540	936	FTF20020	FTF20040
1" × 20 ft.	2.5 × 600	1040	FTF20021	FTF20041	

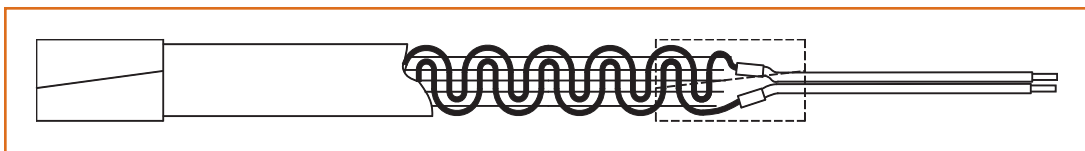

Silicone Rubber Heating Tapes with Thermostat or Time Percentage Control



FTF3 with Adjustable Thermostat Control

* Adjustable Thermostat: 50°F to 425°F (10°C to 218°C)

NOTE: The heat sensing plate on the bottom of the thermostat enclosure must make firm contact with the load being sensed.

Design Features:

- * Maximum exposure temperature: 450°F (232°C)
- * Moisture and chemical resistant silicone rubber extruded outer sheath
- * Fiberglass reinforced serpentine-wound stranded heating element
- * Rapid heat-up and thermal response
- * Power density: 6.0 watts/inch²
- * 6 foot (2 m) long power cord with
120VAC: standard 2-prong NEMA 1-15 plug
240VAC: bare wire connection
- * Suitable for electrically conductive surfaces

FTF4 with Time Percentage Control

* Easily adjust percentage of time heater is on and off: 0 to 100%

NOTE: The time percentage control varies the length of time the heater is the on vs. off heating mode. The controller does not use a temperature sensor and therefore requires occasional supervision under changing load conditions.

Typical Applications

- ↔ Valves
- ↔ Pipes
- ↔ Bearings
- ↔ Pumps
- ↔ Gas Tubing
- ↔ Filter Housings
- ↔ Actuators
- ↔ De-icing

Width		Length		Watts	Part Number - Thermostat		Part Number - %Control	
in	mm	in	mm		120V	240V	120V	240V
0.5	13	24	610	72	FTF30001	FTF30021	FTF40001	FTF40021
0.5	13	48	1220	144	FTF30002	FTF30022	FTF40002	FTF40022
0.5	13	72	1830	216	FTF30003	FTF30023	FTF40003	FTF40023
0.5	13	96	2440	288	FTF30004	FTF30024	FTF40004	FTF40024
0.5	13	120	3050	360	FTF30005	FTF30025	FTF40005	FTF40025
1.0	25	24	610	144	FTF30006	FTF30026	FTF40006	FTF40026
1.0	25	48	1220	288	FTF30007	FTF30027	FTF40007	FTF40027
1.0	25	72	1830	432	FTF30008	FTF30028	FTF40008	FTF40028
1.0	25	96	2440	576	FTF30009	FTF30029	FTF40009	FTF40029
1.0	25	120	3050	720	FTF30010	FTF30030	FTF40010	FTF40030
2.0	51	24	610	288	FTF30011	FTF30031	FTF40011	FTF40031
2.0	51	48	1220	576	FTF30012	FTF30032	FTF40012	FTF40032
2.0	51	72	1830	864	FTF30013	FTF30033	FTF40013	FTF40033
2.0	51	96	2440	1152	FTF30014	FTF30034	FTF40014	FTF40034
2.0	51	120	3050	1440	FTF30015	FTF30035	FTF40015	FTF40035
3.0	76	24	610	432	FTF30016	FTF30036	FTF40016	FTF40036
3.0	76	48	1220	864	FTF30017	FTF30037	FTF40017	FTF40037
3.0	76	72	1830	1296	FTF30018	FTF30038	FTF40018	FTF40038
3.0	76	96	2440	1440*	FTF30019	FTF30039	FTF40019	FTF40039
3.0	76	120	3050	1440*	FTF30020	—	FTF40020	—
3.0	76	120	3050	1800*	—	FTF30040	—	FTF40040

The FTF3 thermostats shown have a °F temperature label. For a °C temperature label, consult Tempco.

*Derated watt density due to maximum current limits

Thick Film

Printed Thick Film Heating Elements

Tempco's flexible Thick Film Heating Elements offer a wide range of design options for OEM applications. By utilizing printed thick film technology, the heaters can more efficiently spread the heat across the surface, and are more cost effective systems when compared to etched foil or wire elements.

The ink can be designed in various patterns and densities, concentrating power exactly where it is needed. The element traces can be widened or narrowed to allow for cutouts and holes.

Construction

Conductive and resistive inks are printed on a film substrate layer, and then covered with another film layer laminated together with pressure sensitive adhesive (PSA). Typically, the film layers are .005" thick thermoplastic or thermoset polymers, like polyester (up to 105°C) or polyimide (up to 180°C), that exhibit good thermal conductivity while serving as electrical insulators.

An additional layer of PSA can be added to the bottom of the assembly so the element can be bonded directly to the surface to be heated, ensuring excellent thermal transfer.

Cooler Operating Temperature

By spreading the heat trace over a larger percentage of the surface of the element, as compared to wire wound elements, a Tempco thick film element will operate at a cooler operating temperature due to the lower watt density in a given area. The low thermal mass of the heater allows the heat to be transferred more quickly to the surface to be heated.

Controls and Sensors

More exacting control is available for the heaters as well. Thermostats and temperature sensors can be mounted directly on the heaters for direct temperature control. Thermal fuses/TCOs are available for overtemperature/runaway condition protection.

Typical Applications

- ↔ *Blanket Heaters for Battery Back up Systems*
- ↔ *Video Camera Lens Defoggers*
- ↔ *Outdoor Enclosure Warmers*
- ↔ *Fluorescent Bulb Starters*
- ↔ *Clear LCD Heaters*
- ↔ *Packaging/Sealing Bar Element*
- ↔ *Medical Equipment*
- ↔ *Food Service Equipment*
- ↔ *Mirror Heater/Defoggers*

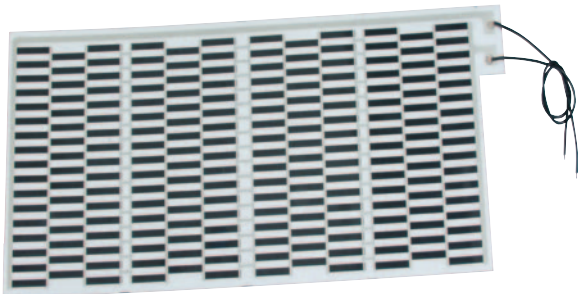

Specifications

Overall Maximum Temperature: 900°F (482°C)

Substrate Materials – Maximum Ratings

Polyester: 221°F / 105°C

Polyethylene: 221°F / 105°C

Polyvinyl Chloride (PVC): 221°F / 105°C

Thermoset Laminate: 284°F / 140°C

Polyethylene Naphthalate (PEN): 320°F / 160°C

Polyimide (Kapton®): 392°F / 200°C

Silicone Rubber: 392°F / 200°C

Pressure Sensitive Adhesive

Acrylic: 221°F / 105°C

High Temperature Acrylic: 300°F / 149°C

Silicone: 392°F / 200°C

Dimensional Limits

Minimum Width: 0.25" (6mm)

Maximum Length: 30" (508mm)

Heaters can be manufactured that have a length much greater than the width. Up to 24" x 98" have been made.

Electrical

Voltage: Up to 277 VAC or VDC

Watt Density: Standard, up to 25 w/in².

Can go higher under certain conditions.
Consult Tempco with your requirements.

Dielectric Strength: 1500 VAC

Ordering Information

Custom Engineered / Manufactured Heaters

Understanding that an electric heater can be application specific, Tempco will design and manufacture a Thick Film Heater to meet your requirements. Copy the form on page 9-22, fill it out, and fax it to Tempco to receive a quote.

⚠ WARNING: Cancer and Reproductive Harm - www.P65Warnings.ca.gov.



Table Of Contents

Pictorial Index	A-24	Tubular Heaters for Hot Runner Manifolds	10-13
Tubular Heater Introduction and Specifications	10-2	Standard Sizes and Ratings	10-14
Tubular Heater Terminations	10-4	Finned Tubular Heaters	10-16
Tubular Heater Mounting Methods	10-6	Single Ended Tubular	10-16N
Tubular Heater Moisture Seals	10-8	Quote Request Form.....	10-18
Typical Bend Formations	10-9		

10

section

Tubular Heaters

Introduction

Tubular Heater Introduction

Typical Applications

- ↔ *Forced air heating*
- ↔ *Thermal forming machines*
- ↔ *Direct immersion in liquids*
- ↔ *Comfort radiant heaters*
- ↔ *Welded, brazed or clamped to tanks and pipes*
- ↔ *Hot runner molds*
- ↔ *Combination radiant and convection heater for ovens and dryers*

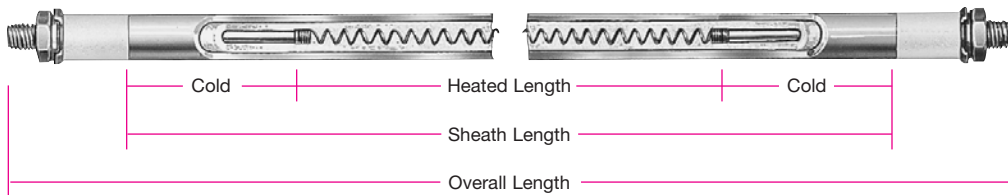

Design Guidelines

Resistance Tolerance

Tubular heating elements have an Industry Standard Resistance Tolerance of +10%, -5% which translates to a Wattage Tolerance of +5%, -10%. Consult Tempco if tighter tolerances are required for your application.

Watt Density

Element Watt Density is the wattage dissipated per square inch of the element sheath surface and is critical to the proper heating of the application and to the life expectancy of the heater. The Watt Density is calculated with the following formula:

$$\text{Watt Density (w/in}^2\text{)} = \frac{\text{Element Wattage}}{\pi \times \text{Element Dia.} \times \text{Element Heated Length}}$$

For a particular application element watt density will govern element sheath and internal resistance wire temperature. Factors to consider when choosing a suitable watt density are:

1. Many materials are heat sensitive and can decompose or be damaged if the element is running too hot.
2. Air and other gases that are poor conductors of heat require watt densities matched to the velocity of the gas flow to prevent element overheating.
3. When heating hard water or cleaning solutions, mineral deposits can build up on the element sheath, acting as a heat insulator and raising the internal element temperature. If these deposits cannot be periodically removed, use a lower watt density element to increase heater life expectancy.
4. When tubular heaters are used in UL recognized oil immersion heating applications the heated oil temperature cannot exceed 257°F (125°C). Steel sheath elements are limited to 60 watts/in². Tubular heaters with steel or stainless steel bulkhead fittings used in UL oil heating applications are not pressure rated. Contact Tempco for other application specific UL file information.
5. Page 16-12 in the Engineering Data Section of this catalog lists the maximum recommended heater watt density for many materials. For additional information and help please contact Tempco.

Construction Characteristics

Tempco Tubular Heaters are the most versatile and widely used source of electric heat for industrial, commercial and scientific applications. They can be designed in a wide range of electrical ratings, diameters, lengths, terminations, and sheath materials. Important and useful characteristics of tubular heaters are that they can be formed into virtually any shape, brazed or welded to any metal surface, and cast into metals. Carefully researched manufacturing methods and quality materials have made Tempco tubular heaters stand apart from other heating elements claiming similar performance.

The cutaway view shows the tubular heater's basic construction. A computer-designed helical coil of 80% Nickel 20% Chromium alloy resistance wire is fusion welded to the nickel-coated steel terminal cold pin. This coil assembly is precisely stretched and centered in the element metal sheath, which is then filled with Grade "A" Magnesium Oxide powder (MgO). The filled tube is then compacted by a roll reduction mill

into a solid mass, permanently stabilizing the coil in the center of the tube while providing excellent heat transfer and dielectric strength between the coil and the sheath.



Tempco Tubular Heating Elements are certified as Recognized Components by Underwriters Laboratories (File Number E90771) under CCN UBJY2/8 to meet UL Standard UL1030. Tempco's equivalent CSA File Number is 043099. Tubular elements with bulkhead fittings have also been certified for oil heating (File Number MP4154) under CCN MDST2/8 to meet UL Standard 574.

If you require UL, CSA, or other NRTL agency approvals, please specify when ordering.



Important Note — When heating any substance it is critical to match the heater watt density, operating temperature and sheath material to the specific medium being heated. Failure to do so will result in premature heater failure and/or unsafe conditions.

View Product Inventory @ www.tempco.com

Tubular Heater Standard Specifications

Element Diameter		Maximum Voltage	Maximum Amperage	Resistance in Ohms per Heated Inch		Sheath Length			
in	mm			min	max	min.		max.	
						in	mm	in	mm
.260	6.6	250	15	.100	17	11	279	200	5080
.315	8.0	480	30	.060	21	11	279	200	5080
.375	9.5	600	30	.040	21	11	279	200	5080
.430	10.9	600	40	.040	21	11	279	255	6807
.475	12.1	600	40	.040	21	11	279	255	6807
.625	15.9	600	40	.040	17	11	279	255	6477

Table 1 Electrical Limitations and Minimum/Maximum Sheath Lengths

Length		Sheath Length Tolerance (±)		Heated Length Tolerance (±)		Minimum Unheated Length Each End	
in	mm	in	mm	in	mm	in	mm
11-20	279-508	3/32	2.4	1/4	6	1	25
20-50	508-1270	1/8	3.2	1/2	13	1-1/4	32
50-80	1270-2032	5/32	4.0	7/8	22	1-1/2	38
80-110	2032-2794	3/16	4.8	1-1/8	29	1-5/8	42
110-140	2794-3556	7/32	5.6	1-3/8	35	1-3/4	44
140-170	3556-4318	1/4	6.4	1-5/8	41	2	51
170-200	4318-5080	3/8	9.5	1-7/8	48	2-1/4	57
200-up	5080-up	1/2	12.7	2-3/8	60	2-1/2	64

Table 2 Sheath and Heated Length Tolerance (applicable for all diameters)

Tubular Heater Standard Sheath Materials

The selection of a sheath material should be made based on the chemical composition of the gas or liquid being heated, the characteristics of the materials entering the solution, and the processes controls. A material selection guide can be found on page 16-12.

NOTE: The best source for chemical/sheath compatibility is the supplier of the gas or liquid to be heated.

The following are the most common tubular element sheath materials. For other materials consult Tempco.

Incoloy® 840: Nickel 18-20%, Chromium 18-22%, Iron balance. Has about 10% less nickel than Incoloy 800. Used in many air heating applications, where it has exhibited superior oxidation resistance at less cost than Incoloy 800.
Maximum Sheath Temperature: 1600°F / 871°C

Incoloy® 800: Nickel 30-35%, Chromium 19-23%, Iron balance. The high nickel content of this alloy contributes to its resistance to scaling and corrosion. Used in air heating and immersion heating of potable water and other liquids.
Maximum Sheath Temperature: 1600°F / 871°C

316 Stainless Steel: Chromium 16-18%, Nickel 11-14%, Iron balance. Modified with the addition of Molybdenum (2-3%) to improve corrosion resistance in certain environments, especially those which would tend to cause pitting due to the presence of chlorides. Applications include deionized water.
Maximum Sheath Temperature: 1200°F / 649°C

304 Stainless Steel: Chromium 18-20%, Nickel 8-11%, Iron balance. Used in the food industry, medical, and chemical heating.
Maximum Sheath Temperature: 1200°F / 649°C

321 Stainless Steel: Chromium 17-20%, Nickel 9-13%, Iron balance. Modified with the addition of Titanium to prevent carbide precipitation and resulting intergranular corrosion that can take place in certain mediums when operating in the 800-1200°F (427-649°C) temperature range.
Maximum Sheath Temperature: 1200°F / 649°C

Copper: Standard Copper Alloy

A low temperature, inexpensive material used mainly for clean water heating.

Maximum Sheath Temperature: 350°F / 177°C

Steel: Low Carbon

Used for high to low viscosity oils, asphalt, tar, wax, molten salt, heat transfer liquid media and other compatible solutions.

Maximum Sheath Temperature: 750°F / 399°C

Other Sheath Materials: Available for a limited number of diameters. Consult Tempco for more information.

Inconel® 600: Iron 6-10%, Chromium 14-17%, Nickel balance
Maximum Sheath Temperature: 1800°F / 982°C

Incoloy® 825: Nickel 38-46%, Chromium 19.5-23.5%, Molybdenum 2.5-3.5%, Iron balance
Maximum Sheath Temperature: 1100°F / 593°C



Maximum Sheath Temperature refers to the maximum temperature of the element sheath material.

Consideration must be given to the maximum temperature that can be safely applied to the heated material.

See **Watt Density** on the previous page for additional information.

Incoloy® and Stainless Steel Element Sheath Surface Treatments

Standard Surface Finish

The standard tubular heater element surface finish is a black chrome oxide, produced when the element is annealed prior to forming in an exothermic atmosphere furnace.

Optional Surface Finishes

Bright Annealing is an option where the tubular heater is annealed in a dissociated ammonia atmosphere furnace. This produces a clean metallic appearance without surface-etching the sheath.

Electro-Polishing is an electrochemical process that removes surface imperfections and contaminants, enhancing the corrosion resisting ability of the sheath. The resulting surface is clean, smooth and has a bright finish; it is highly recommended for medical, food and other harsh applications.

Passivation removes surface contamination, usually iron, so that the optimum corrosion resistance of the stainless steel is maintained. Surface contamination could come from the small amount of steel that may be worn off a tool during the manufacturing process.

Standard Tubular Heater Terminations

Select the termination style that meets your requirements for space, accessibility and reliability.

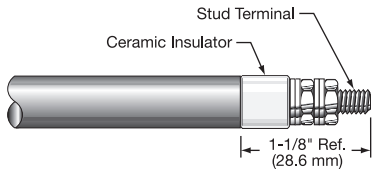

TYPE T—STANDARD

Threaded stud terminal with ceramic insulator.

Element Diameter		Standard Thread Size
in	mm	
.260	6.6	6-32
.315	8.0	8-32
.375	9.5	8-32
.430	10.9	10-32
.475	12.0	10-32
.625	15.9	10-32

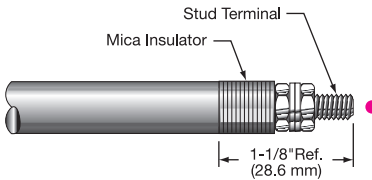

TYPE TM—Stud with Mica Insulator

Stud terminal with mica insulator.

Other thread sizes and lengths are available.



TYPE P—Plain Pin

Plain terminal pin. Specify Length "L." Standard 1/2" (12.7 mm) pin length.

Element Diameter		Nominal Pin Diameter	
in	mm	in	mm
.260	6.6	.091	2.3
.315	8.0	.105	2.7
.375	9.5	.105	2.7
.430	10.9	.125	3.2
.475	12.0	.125	3.2
.625	15.9	.160	4.1

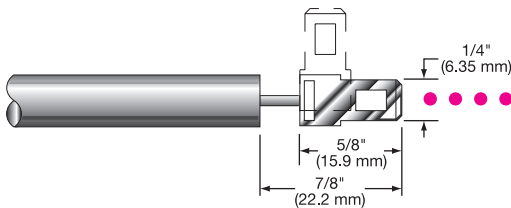

TYPE SF & SF9 (90°)—Quick Connect

1/4" male (3/16" optional) quick connect (slip-on) terminals are welded to the element terminal pin. They provide quick and easy installation of lead wire with excellent holding force. Specify if an optional mica or ceramic insulator is required. Material: Nickel-Plated Steel.

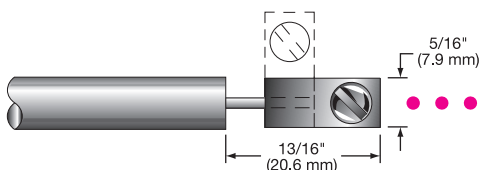

TYPE L_— & L9_— (90°)—Terminal Lug

A nickel-plated steel lug is projection welded to the terminal pin straight (Type "L_—") or at 90° to the sheath (Type "L9_—"). Specify if an optional mica or ceramic insulator is required.

Standard LA, L9A 10-32 screw Optional LB, L9B 8-32 screw

Tubular Heater Standard Terminations

TYPE E__ – Right-Angle Lug Terminal

- Type E1A** 8-32 screw with mica insulator (Standard)
- Type E1B** 8-32 screw with ceramic insulator
- Type E2A** 10-32 screw with mica insulator
- Type E2B** 10-32 screw with ceramic insulator

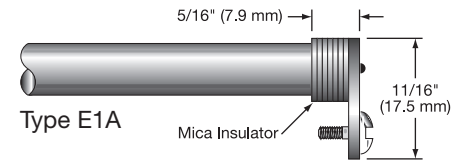

TYPE A__ – Right-Angle Terminal (for use when space is tight)

- Type A1A** 8-32 screw with mica insulator
- Type A1B** 8-32 screw with ceramic insulator
- Type A2A** 10-32 screw with mica insulator
- Type A2B** 10-32 screw with ceramic insulator (Standard)

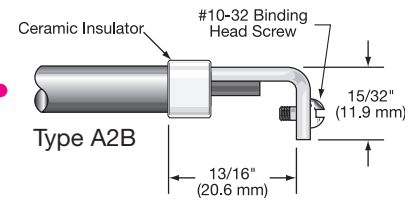

TYPE F1__ – Lead Wire

When selecting a lead wire type, consideration should be given to the maximum ambient temperature the lead wire is exposed to and the environment it is in. Lead wire options Type R1 and W1 below will provide additional environmental protection to the Type F1 lead wire selected.

- Type F1A** 250°C (482°F) TGGT insulation
- Type F1B** 450°C (842°F) MGT insulation
- Type F1C** 200°C (392°F) Teflon® insulation
- Type F1D** 150°C (302°F) Silicone Rubber insulation
- Type F1E** 105°C (221°F) Thermoplastic (PVC) insulation

Standard 10" (254 mm) leads with fiberglass sleeve. Specify if other lead length is required.

F1C F1D & F1E available with optional heat shrink sleeving. Specify when ordering if required.

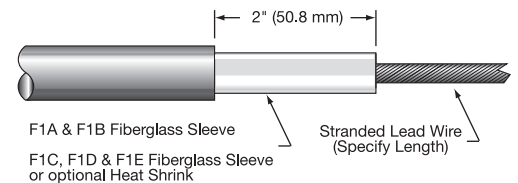

Lead wire gauge is determined by the ampacity of the heater with the lead wires in an ambient temperature of 40°C (104°F). Higher ambients may require heavier gauge lead wires.

Lead Wire Termination Options

TYPE R1__ – Flexible Armor Cable

- Type R1A** Galvanized cable
- Type R1B** Stainless steel cable

Provides excellent protection to lead wires in abrasive environments.
Standard 10" (254 mm) armor cable over 12" (305 mm) leads.
Specify if other lead and/or cable lengths are required.

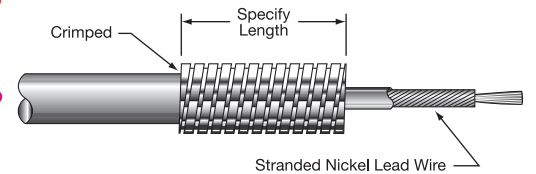

TYPE W1__ – Stainless Steel Wire Braid

Provides good protection to lead wires where flexibility is needed.
Standard 10" (254 mm) braid over 12" (305 mm) leads.
Specify if other lead and/or cable lengths are required.

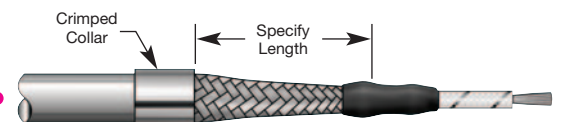

Tubular Heater Standard Mounting Methods

TYPE B – Bulkhead Fittings

Bulkhead fittings provide a leakproof method for mounting tubular heating elements through tank walls. Standard are round brass fittings crimped onto the element that are suitable for low pressure water (up to 80 psig) and non-pressure air. A brass hex nut, plated steel washer and gasket are supplied as standard.

Fittings for vacuum or high pressure gas and liquid use are silver brazed or TIG welded. Method will vary by material and application. Fittings in table are most commonly used. Special fittings can be made to meet your application requirements.

Standard fitting location is with threads flush at the end of the element sheath as shown below. For other locations specify distance from end of sheath.

CAUTION Do not locate the fitting over the heated section of the element.

Specify: Material; Round (Standard) or Hex Flange; Thread Type and Length; Location on Sheath; Crimped, Brazed, or Welded Construction.

Fitting Attachment Method — General Guidelines

These are guidelines only. Consult Tempco if you require assistance in determining the method best suited to your application.

Fittings Crimped: Low pressure water (up to 80 psig) and non-pressure air applications

Fittings Brazed: Non-ferrous alloys (copper) and dissimilar non-weldable metals

Fittings Welded: High pressure liquids and gases, and high temperature applications

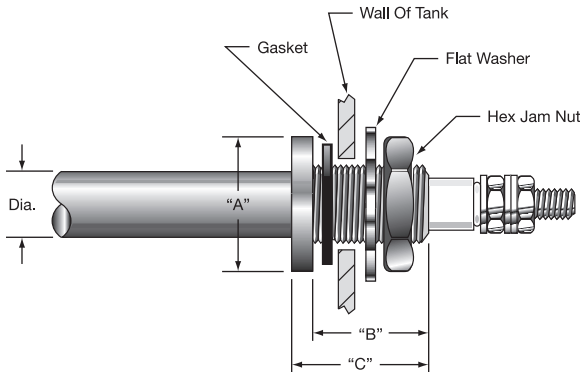

Standard Bulkhead Fittings For Tubular Heaters — Round Flanged Standard

Tubular Diameter		Fitting Material	Flange Type	"A"		"B"		"C"		Thread Size (UNF)
in	mm			in	mm	in	mm	in	mm	
.260	6.6	Brass	Round	3/4	19	1/2	12.7	5/8	16	1/2-20
.260	6.6	Stn. Stl.	Round	3/4	19	1/2	12.7	5/8	16	1/2-20
.315	8.0	Brass	Round	3/4	19	1/2	12.7	5/8	16	1/2-20
.315	8.0	Stn. Stl.	Round	3/4	19	1/2	12.7	5/8	16	1/2-20
.375	9.5	Brass	Round	3/4	19	1/2	12.7	5/8	16	1/2-20
.375	9.5	Stn. Stl.	Round	3/4	19	1/2	12.7	5/8	16	1/2-20
.430	10.9	Brass	Round or Hex	7/8	22	3/4	19.0	7/8	22	5/8-18
.430	10.9	Stn. Stl.	Round or Hex	7/8	22	3/4	19.0	7/8	22	5/8-18
.430	10.9	Steel	Round	7/8	22	3/4	19.0	7/8	22	5/8-18
.475	12.1	Brass	Round	7/8	22	3/4	19.0	7/8	22	5/8-18
.475	12.1	Stn. Stl.	Round	7/8	22	3/4	19.0	7/8	22	5/8-18
.475	12.1	Steel	Round	7/8	22	3/4	19.0	7/8	22	5/8-18
.475	12.1	Brass	Round	1	25	3/4	19.0	7/8	22	3/4-16
.475	12.1	Stn. Stl.	Round	1	25	3/4	19.0	7/8	22	3/4-16
.625	15.9	Stn. Stl.	Round	1-1/8	29	3/4	19.0	1	25	7/8-14



Note: Optional Larger Thread Sizes and Hex Flanged Bulkhead Fittings are available. Consult Tempco with your requirements.

Tubular Heater Standard Mounting Methods

Part Number	For Element Diameter		"A" Thick		"B" OD	
	in	mm	in	mm	in	mm
FAS-108-102	.260	6.6	5/16	7.9	5/8	15.9
FAS-108-102	.315	8.0	5/16	7.9	5/8	15.9
FAS-108-103	.375	9.5	3/8	9.5	3/4	19.1
FAS-108-104	.430	10.9	7/16	11.1	7/8	22.2
FAS-108-106	.475	12.0	7/16	11.1	1	25.4

TYPE MC – Mounting Collar

Plated steel mounting collars are locked in place with a set-screw and serve as an adjustable stop for through-the-wall mounting. Collars are shipped in bulk unless otherwise specified. Mounting collars can be ordered with the heater or purchased separately.

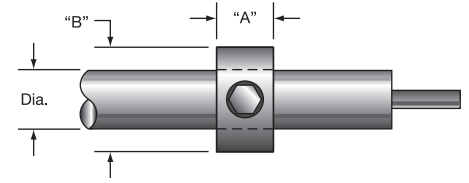

TYPE LR – Locator Washer

Locator washers are permanently attached to the heater sheath by staking/crimping and are used to limit the movement of the heater while allowing for expansion and contraction of the heater sheath. When ordering, specify location from end of sheath.

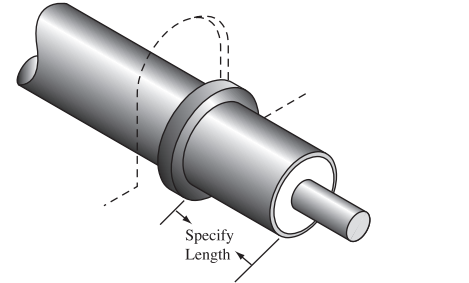

Multiple element heater assembly with a custom mounting bracket.



TYPE MF – Mounting Bracket

Tempco's made-to-order mounting brackets are made from 18 gauge stainless steel for strength and stiffness. It is an economical way to mount the heater in non-pressurizing, non-liquid applications. Unless otherwise specified, the bracket will be located 1/2" from the edge of the heater sheath. OEM quantity brackets are manufactured by Tempco on our own high speed precision N/C Turret Press. The standard method of attaching the tubular element to the bracket is staking or crimping.

The rectangular mounting bracket shown at right is a popular made-to-order design. Specify all dimensions shown when requesting a quote.

Custom brackets of any size, thickness or material can be supplied to meet your requirements.

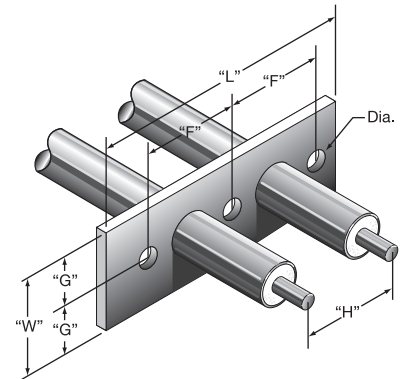

Tubular Heater Standard Moisture Seals

Magnesium Oxide (MgO) is used as the insulating material in Tempco tubular heaters because of its excellent thermal conductivity and dielectric strength. However, MgO is hygroscopic and can absorb moisture from the atmosphere. This absorption of moisture may be detected when an Insulation Resistance (IR) test is done with a megohmmeter prior to energizing the heater circuit. In very humid environments, circuits utilizing a GFI (ground fault interrupter) for safety may experience nuisance tripping when energizing the heater.

The Tempco manufacturing process produces a dry element with an IR of several thousand megohms minimum. However, after shipment and depending on humidity levels and storage time, a heater can absorb moisture and show a decrease in IR. In many cases, depending on the supply voltage and the application, the heater can be safely energized and will dry itself out.

Style SS—Silicone Resin Seal

A brushed-on coating that penetrates the MgO, offering economical moisture protection under humid storage conditions.

Maximum Usable Termination Temperature: 390°F (200°C)

UL Rated Maximum Termination Temperature: 221°F (105°C)

Type V2A: conformal coating

Type V2B: silicone oil

Style SER—RTV Seal

RTV (room temperature vulcanizing) silicone rubber adhesive sealant provides a good moisture seal.

UL Rated – Maximum Termination Temperature:

Type R: 302°F (150°C)

Type R1: 392°F (200°C)

If a heater has absorbed moisture, a safe and effective method of drying it out prior to installation is to bake it in an oven at 300°F (149°C) until an acceptable IR reading is obtained. When possible, removing the terminal hardware will expedite this process. If this method is not practical consult factory for other recommendations.

For applications where moisture absorption would be unacceptable Tempco has several optional element end seals to retard absorption of moisture in the MgO. If a true hermetic seal is required, ceramic to metal end seals (Type H) are available. With any of these seals, the maximum recommended termination temperature in the seal area must not be exceeded.

Style SEH—Epoxy Resin Seal

Epoxy resin provides a moisture resisting barrier.

UL Rated – Maximum Termination Temperature:

Type V: 194°F (90°C)

Type V1: 266°F (130°C)

Type V4: 392°F (200°C)

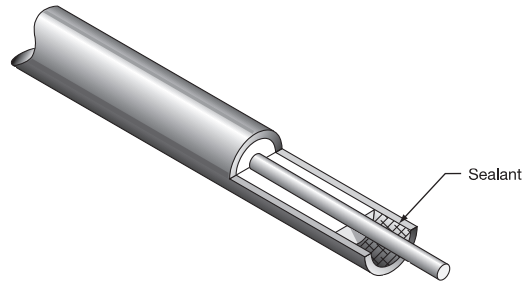

TYPE M—Self Sealing Heat Shrinkable Boot with Lead Wire

This type seal is used primarily for defrost heaters.

Temperature range -67 to 300°F (-55 to 149°C).

Standard 10" (254 mm) leads; specify longer leads if required.

Heater Diameter		"A"		"B"	
in	mm	in	mm	in	mm
.260	6.6	2-1/8	54	7/16	11
.315	8.0	2-1/8	54	7/16	11
.430	10.9	2-1/8	54	9/16	14

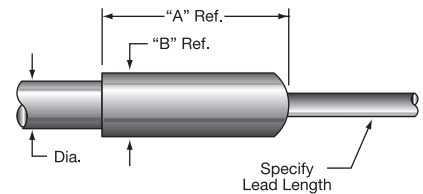

TYPE H—Hermetic Seal

Ceramic to metal seals provide an airtight seal for temperatures to 500°F (260°C) in the seal area.

Heater Diameter		"A"		"B"		Thread Size
in	mm	in	mm	in	mm	
.260	6.6	1-11/16	43	13/32	10	8-32
.315	8.0	1-11/16	43	13/32	10	10-32
.430	10.9	2-1/8	54	21/32	17	1/4-28
.475	12.1	2-1/8	54	21/32	17	1/4-28

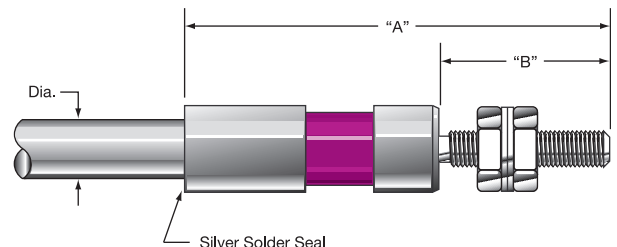

Tubular Heater Standard Bend Formations

Forming Tubular Elements

The MgO insulation used in tubular heating elements is compacted by reducing the element diameter in a roll reducing mill. The elements are then annealed in a controlled atmosphere furnace to relieve the metal stressing (work hardening) that takes place during the rolling to size reduction of the sheath. Annealing brings the metal back to a soft state, allowing the element to be bent into virtually any configuration. However, since forming also work hardens the metal, some precautions must be observed in order to prevent the sheath from breaking during bending or developing stress cracking marks.



Note: Elements with tight bends and some applications require the bends to be recompacted in special dies to restore the integrity of the insulation density and maintain dielectric strength. Large bends do not need to be recompacted.

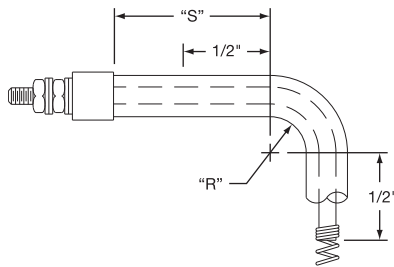

Avoid bends within a minimum of 1/2" of the terminal pin and resistance wire junctions unless the bending radius is a minimum 3" (75 mm).

Elements are being fed into a roll reducing mill to compact the MgO insulating powder. After rolling, the elements are annealed in the conveyor belt furnace seen in the background.



Note: Smaller inside bending radius than listed in the table can be factory accomplished. It requires special forming techniques to prevent damage to the tubular heater. Consult Tempco with your requirements.

Element Diameter		Factory Bend Minimum R		Field Bend Minimum R		Minimum S	
in	mm	in	mm	in	mm	in	mm
.260	6.6	3/8	9.5	3/4	19.1	1/2	12.7
.315	8.0	1/2	12.7	1	25.4	1/2	12.7
.375	9.5	9/16	14.3	2	50.8	5/8	15.9
.430	10.9	3/4	19.1	2-1/2	63.5	3/4	19.1
.475	12.0	7/8	22.2	2-1/2	63.5	1	25.4

TYPICAL Bend Formations

We do custom formations. Contact Tempco with your requirements.

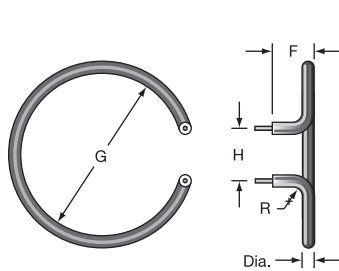

FT1

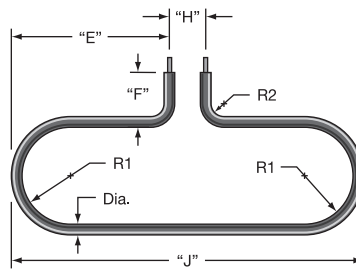

FT2

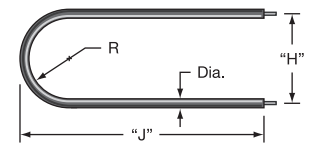

FT3

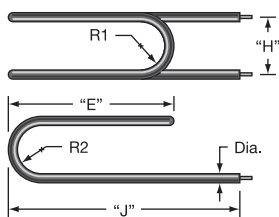

FT4

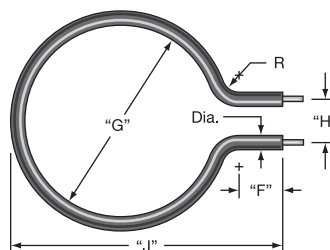

FT5

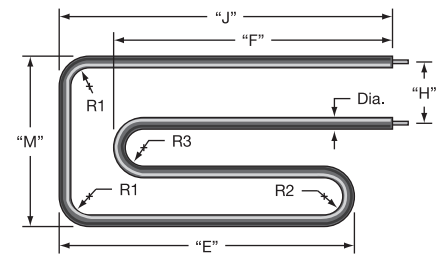

FT6

Tubular Heater Standard Bend Formations

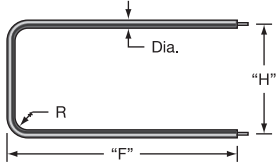

FT7

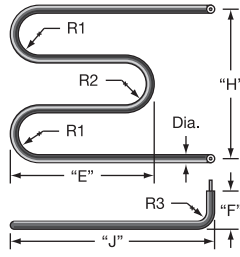

FT8

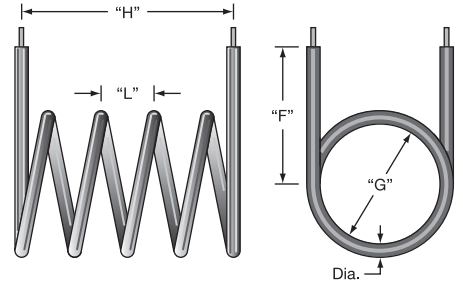

FT9

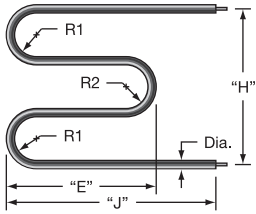

FT10

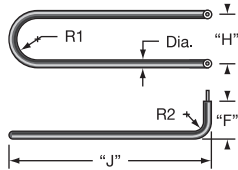

FT11

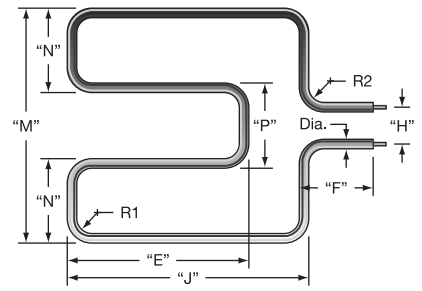

FT12

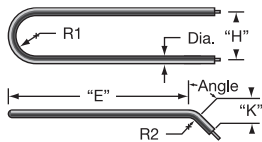

FT13

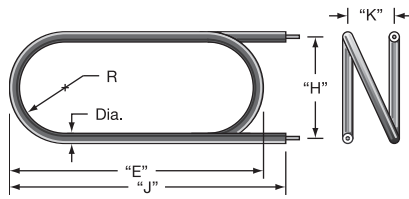

FT14

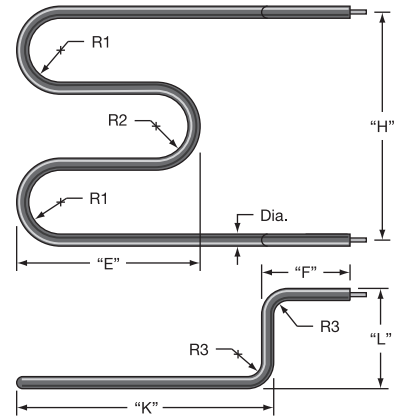

FT15

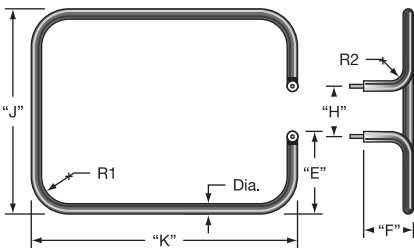

FT16

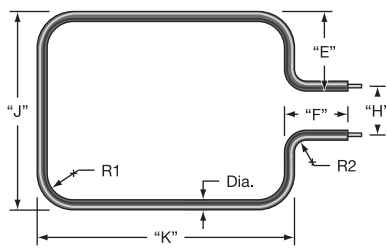

FT17

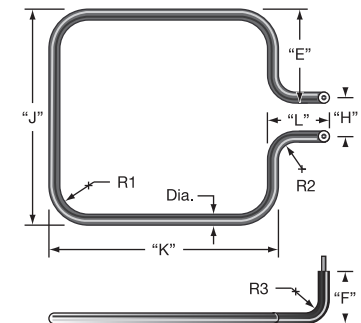

FT18

Tubular Heater Standard Bend Formations

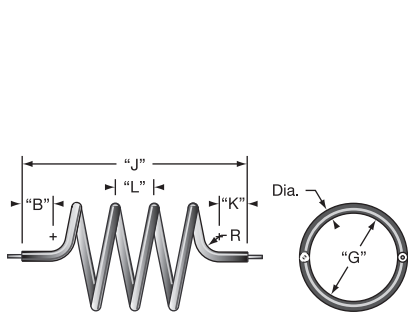

FT19

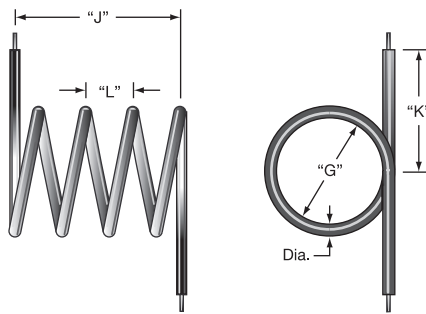

FT20

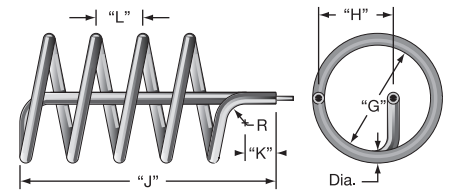

FT21



We do custom formations.
Contact Tempco with
your requirements.

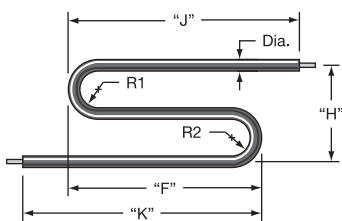

FT22

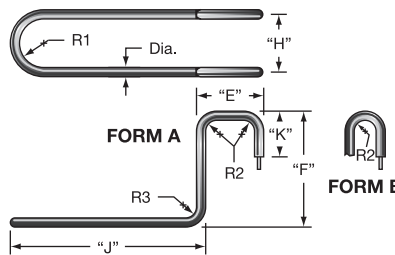

FT23

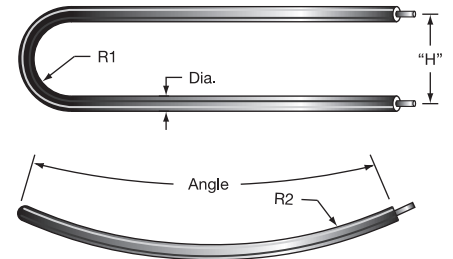

FT24

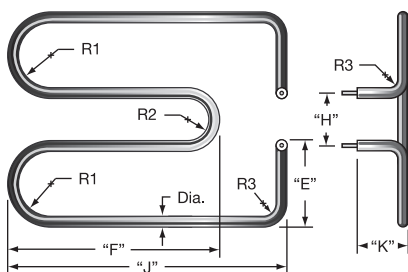

FT25

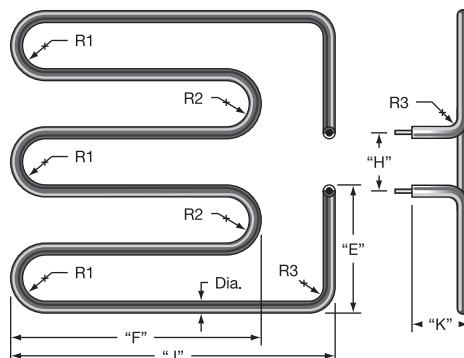

FT26

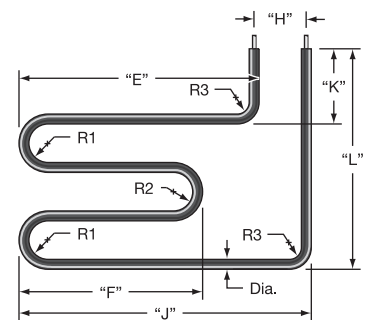

FT27

Bend Formations

Tubular Heater Standard Bend Formations

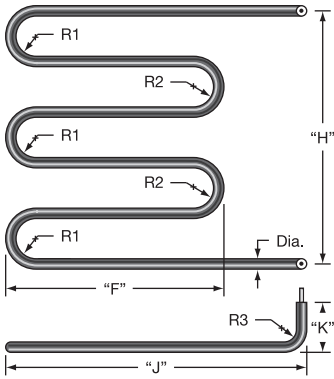

FT28

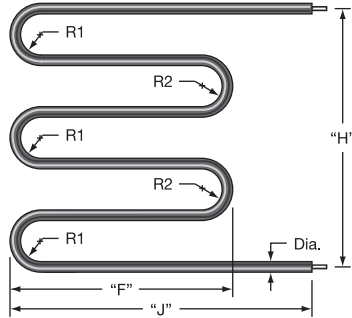

FT29

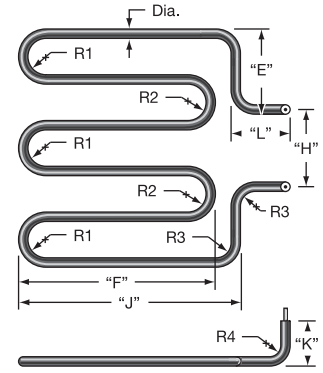

FT30

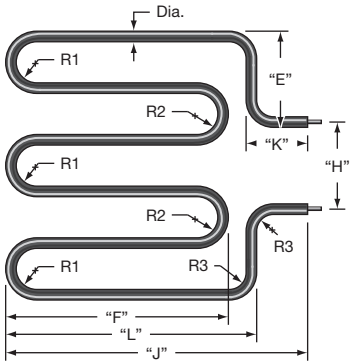

FT31

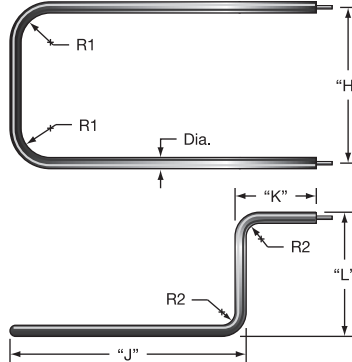

FT32

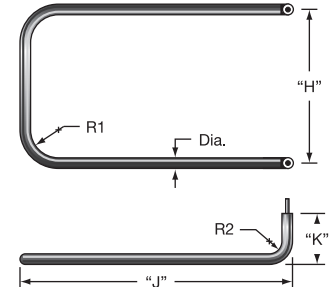

FT33

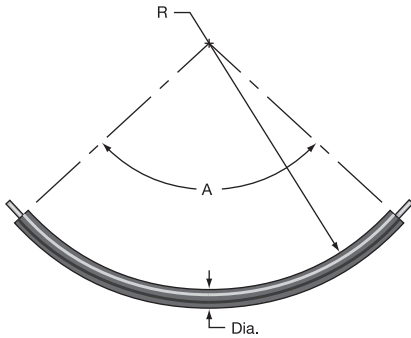

FT34

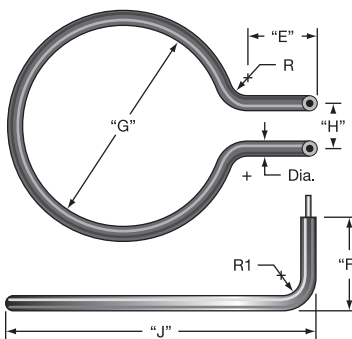

FT36

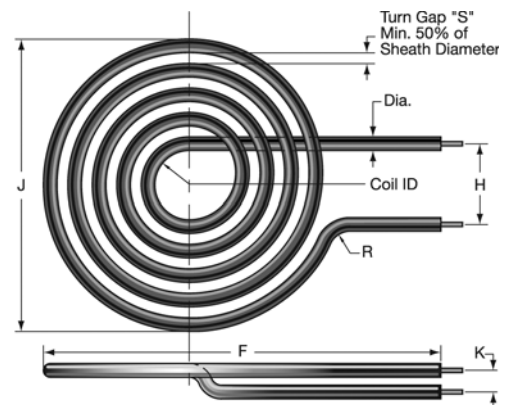

FT37

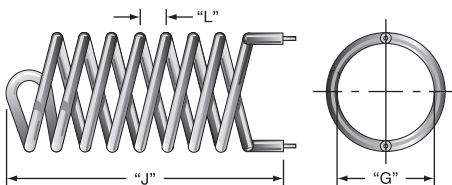

FT35

Tubular Heaters for Hot Runner Manifolds

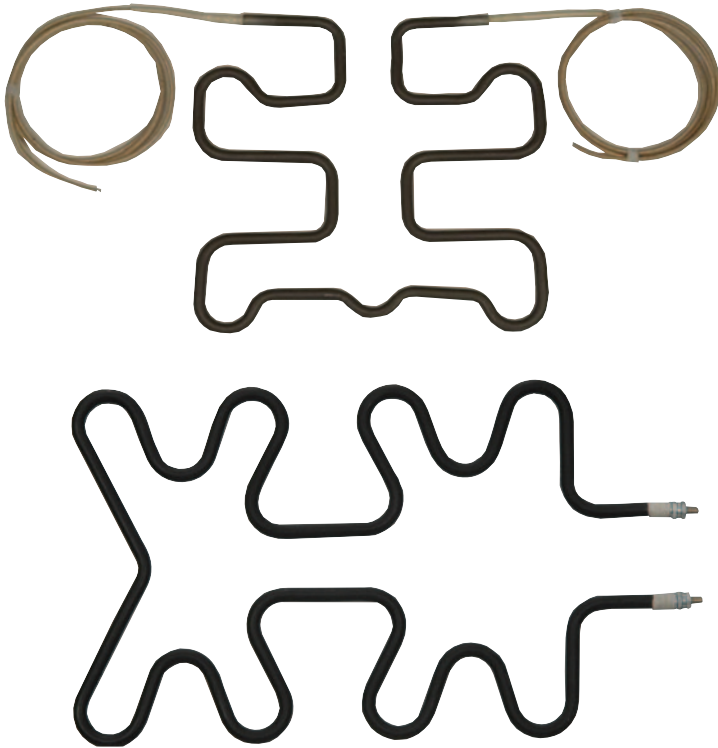

Construction

Hot Runner Manifold Heaters are made to order using .260", .315" or .375" diameter Incoloy® tubular heating elements. Commonly specified terminations include threaded stud or wire leads.

Important Information on Forming

Precise forming of the tubular heater is required for it to seat properly into the milled slot in the manifold. To ensure this fit, we use a physical template as an inspection tool in the forming process to verify bending accuracy.

The template is a reproduction of the milled slot in the form of a plastic or aluminum plate. It can be customer supplied or manufactured by Tempco. Only through the use of a forming template is bending accuracy guaranteed.

When ordering for new applications:

Supply a drawing or forming template if available.

When ordering for replacement:

Supply a sample heater and/or a drawing of the manifold indicating the milled heater slot.



Note: For heaters originally manufactured by Tempco only the Tempco Part Number is required.

Examples of Mold Heater Formations

*Consult Tempco With Your Requirements.
We Welcome Your Inquiries.*

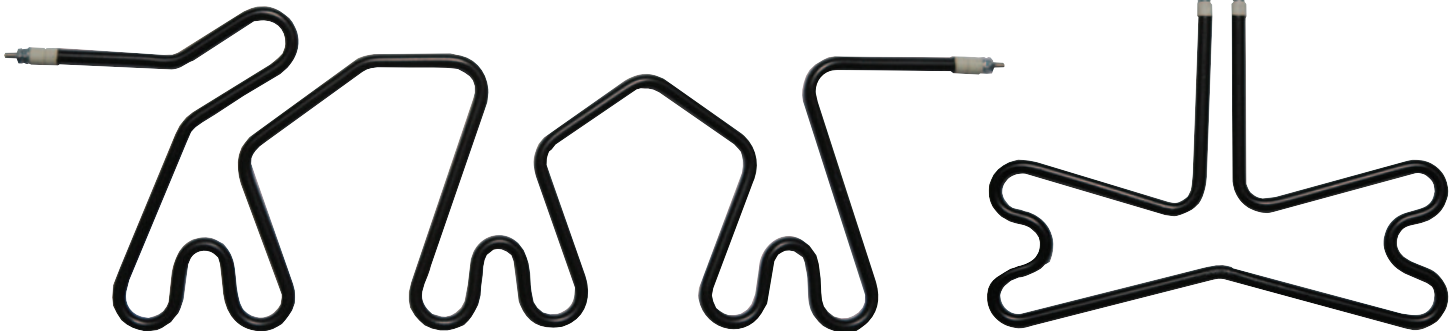

Heat Transfer Cement

When tubular heating elements are used in a milled slot any air gaps between the element and the plate can cause hot spots on the element. Heat transfer cement is used to fill these air gaps, permitting the heater to run cooler, thus maximizing its life expectancy. Cement is water soluble and can be applied with a putty knife or trowel and can be used in temperatures up to 1250°F (675°C).

Part Number SEA-108-101 (1 Gallon)
SEA-108-102 (1 Quart)

Ordering Information

TEMPCO will design and manufacture a Tubular Hot Runner Manifold Heater to meet your requirements.

Please Specify the following:

- Wattage and Voltage
- Diameter
- Heated Length
- Unheated Length at each end
- Termination Type (see pages 10-4 and 10-5)
- Supply a Drawing or Template

WARNING: Cancer and Reproductive Harm - www.P65Warnings.ca.gov.

(800) 323-6859 • Email: sales@tempco.com

Tubular Heater Standard (Non-Stock) and Stock Sizes and Ratings

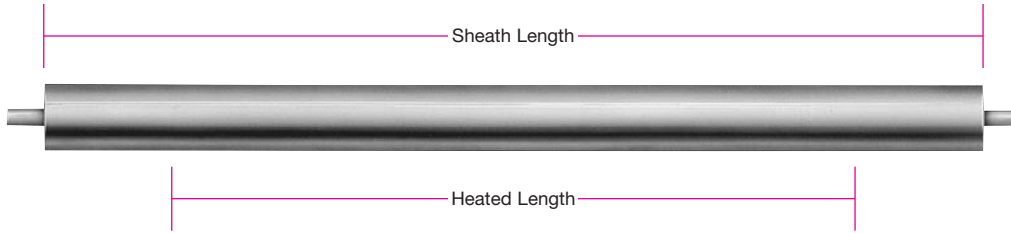

Standard tubular heaters are fully annealed for field or factory bending. They are inventoried with plain pin extensions that allow quick installation of Termination Types T, TM, F1, A, E, SF, SF9, L and L9. Part Numbers listed are for heaters with Type “T” termination. For other terminations a Part Number will be issued at time of order.

Standard (Non-Stock) and Stock Sizes and Ratings with Type T Termination

Stock Items Are Shown In RED

Element Description	Sheath Length		Heated Length		Watts	Part Number 240V	Approximate Net Weight	
	in	mm	in	mm			lbs	kgs
23 W/in² .475 Dia. Incoloy® 840 12 mm (3.6 W/cm ²)	39	991	27	686	1000	THE04000	1.0	.5
	54	1372	42	1067	1500	THE04001	1.1	.5
	69	1753	57	1448	2000	THE04002	1.3	.6
	84	2134	72	1829	2500	THE04003	1.4	.6
	99	2515	87	2210	3000	THE04004	1.6	.7
	132	3353	120	3048	4175	THE04005	1.7	.8
30 W/in² .260 Dia. Incoloy® 840 6.6 mm (4.7 W/cm ²)	157	3988	145	3683	5000	THE04006	1.8	.8
	20	508	15	381	400	THE04007	.2	.1
	25	635	20	508	500	THE04008	.2	.1
	30	762	25	635	600	THE04009	.2	.1
	35	889	30	762	800	THE03384	.3	.1
	40	1016	35	889	900	THE04010	.3	.1
	45	1143	40	1016	1000	THE04011	.4	.2
	50	1270	45	1143	1200	THE04012	.4	.2
	55	1397	50	1270	1200	THE03383	.4	.2
	60	1524	55	1397	1400	THE03373	.5	.2
	65	1651	60	1524	1600	THE02648	.5	.2
	70	1778	65	1651	1800	THE04013	.6	.3
75	1905	70	1778	1800	THE04014	.6	.3	
80	2032	75	1905	2000	THE04015	.6	.3	
30 W/in² .315 Dia. Incoloy® 840 8.0 mm (4.7 W/cm ²)	15	381	10	254	300	THE04016	.2	.1
	20	508	15	381	400	THE04017	.3	.1
	25	635	20	508	600	THE04018	.3	.1
	30	762	25	635	800	THE04019	.4	.2
	35	889	30	762	900	THE03328	.5	.2
	40	1016	35	889	1000	THE04020	.5	.2
	45	1143	40	1016	1200	THE04021	.6	.3
	50	1270	45	1143	1400	THE04022	.7	.3
	55	1397	50	1270	1600	THE04023	.7	.3
	60	1524	55	1397	1800	THE03134	.8	.4
	65	1651	60	1524	1800	THE04024	.9	.4
	70	1778	65	1651	2000	THE03380	1.0	.5
	75	1905	70	1778	2200	THE04025	1.0	.5
80	2032	75	1905	2400	THE04026	1.1	.5	
90	2286	85	2159	2600	THE04027	1.2	.5	
100	2504	95	2413	3000	THE04028	1.3	.6	



Tubular Heater Standard (Non-Stock) and Stock Sizes and Ratings

Standard (Non-Stock) and Stock Sizes and Ratings with Type T Termination

Stock Items Are Shown In **RED**

Element Description	Sheath Length		Heated Length		Watts	Part Number 240V	Approximate Net Weight	
	in	mm	in	mm			lbs	kgs
30 W/in ² .430 Dia. Incoloy® 840 10.9 mm (4.7 W/cm ²)	15	381	10	254	400	THE04029	.3	.1
	20	508	15	381	600	THE04030	.5	.2
	25	635	20	508	800	THE04031	.6	.3
	30	762	25	635	1000	THE04032	.7	.3
	35	889	30	762	1200	THE04033	.8	.4
	40	1016	35	889	1400	THE04034	.9	.4
	45	1143	40	1016	1600	THE04035	1.0	.5
	50	1270	45	1143	1800	THE04036	1.1	.5
	55	1397	50	1270	2000	THE03415	1.3	.6
	60	1524	55	1397	2200	THE03376	1.4	.6
	65	1651	60	1524	2400	THE04037	1.5	.7
	70	1778	65	1651	2600	THE04038	1.6	.7
	75	1905	70	1778	2800	THE04039	1.7	.8
	80	2032	75	1905	3000	THE04040	1.8	.8
90	2286	85	2159	3500	THE04041	2.0	.9	
100	2540	95	2413	4000	THE03593	2.3	1.0	
110	2794	105	2667	4500	THE03067	2.5	1.1	
120	3048	115	2921	5000	THE04042	2.7	1.2	
40 W/in ² .375 Dia. Incoloy® 840 9.5 mm (6.2 W/cm ²)	21 ¹ / ₁₆	535	16 ¹ / ₁₆	427	800	THE04043	.4	.2
	27 ¹ / ₈	689	22 ¹ / ₈	581	1100	THE04044	.5	.2
	32 ¹ / ₈	816	27 ¹ / ₈	708	1300	THE04045	.6	.3
	42 ¹ / ₈	1089	38 ¹ / ₈	981	1800	THE04046	.8	.4
	57 ¹ / ₂	1461	53 ¹ / ₄	1353	2500	THE04047	1.1	.5
	69 ¹ / ₄	1759	65	1651	3000	THE04048	1.3	.6
	81 ¹ / ₄	2064	77	1956	3600	THE04049	1.5	.7
	109 ¹ / ₄	2775	105	2667	4000	THE04050	2.1	1.0
	134 ¹ / ₂	3416	127 ³ / ₄	3245	5000	THE04051	2.5	1.1
153 ³ / ₈	3896	145 ³ / ₈	3705	5500	THE04052	2.9	1.3	
179 ¹ / ₄	4553	171 ¹ / ₄	4350	6500	THE04053	3.4	1.5	
48 W/in ² .475 Dia. Incoloy® 840 12 mm (7.4 W/cm ²)	23	584	14	356	1000	THE04054	.6	.3
	30	762	21	533	1500	THE04055	.9	.4
	39	991	27	686	2000	THE04056	1.1	.5
	44	1118	35	889	2500	THE04057	1.3	.6
	54	1372	42	1067	3000	THE04058	1.6	.7
	69	1753	57	1448	4000	THE04059	2.0	.9
	84	2134	72	1829	5000	THE04060	2.2	1.0
	99	2515	87	2210	6000	THE04061	2.8	1.3
149	3785	133	3378	9720	THE04062	4.0	1.8	

Ordering Information

Catalog Heaters

Part Numbers in **RED** are in stock for immediate delivery with Type T termination.

Termination Types TM, F1, A, E, SF, SF9, L, and L9 can be applied to stock heaters. For these terminations the Heater Part Number will be issued at time of order.

Non-Stock Part Numbers are standard designs that are available straight in 2 weeks and formed in 4 weeks.

Custom Engineered/Manufactured Heaters

An electric heater can be very application specific; for sizes and ratings not listed, **TEMPCO** will design and manufacture a tubular heater to meet your requirements. **Standard lead time is 4 weeks.**

Please Specify the following:

- Type of Application
- Wattage and Voltage
- Diameter
- Heated Length
- Unheated Length at Each End
- Sheath Material
- Termination Type
- Type of Mounting, if Required
- Type of Moisture Seal, if Required
- Bending Configuration (supply Drawing and/or Sample)

⚠ WARNING: Cancer and Reproductive Harm - www.P65Warnings.ca.gov.

(800) 323-6859 • Email: sales@tempco.com

Tubular Heaters



Finned Tubular Heaters

Finned Tubular Heaters

Shown with optional bulkhead fittings



Shown with optional mounting flange at end of sheath

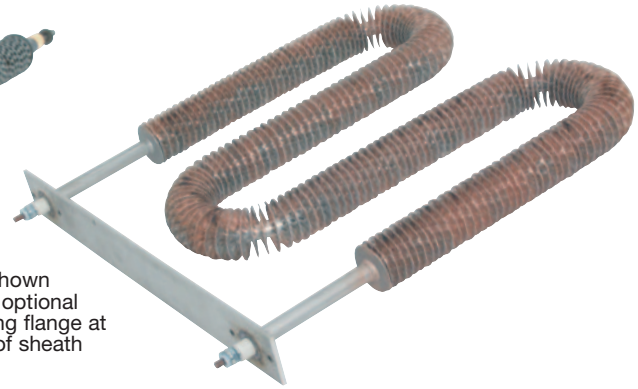

Design Features

- * Copper brazed steel fins on steel sheath standard. Aluminum based protective coating available.
- * Stainless steel fins on stainless alloy sheath standard.
- * .315, .430, & .475 Sheath diameters standard. .260 & .375 diameters optional. .625 diameter is special order in limited lengths.
- * 5/16" fins standard on .315 diameter units, 3/8" fins on .430 & .475 diameter heaters. See physical specifications for optional sizes.
- * Monel fins on Monel sheath available on special order only. Consult Tempco for details.
- * 4.5-5 fins/in standard. 3.5-6 fins/in optional
- * Steel finned catalog heaters have brazed brass bulkheads. Welded steel or staked bulkheads available. Stainless steel welded bulkheads are standard on cataloged stainless steel finned heaters. Fittings will have UNF threads unless custom threads are specified. See page 10-16B.
- * Custom Mounting Brackets can be provided. See page 10-16C.

Construction Characteristics

THF finned heaters are constructed using Tempco's robust tubular element as the basis of construction. Fin material is continuously spiral wound tightly onto the element surface to increase the convective surface area for air and non-corrosive gas heating. Fin spacing and size have been tested and selected to optimize performance. Steel finned units are then furnace brazed, bonding the fins to the sheath to increase conductive efficiency. This allows higher wattage levels to be achieved in the same flow area and produces lower sheath temperatures prolonging heater life. For higher temperature or more corrosive applications, stainless steel fins securely wound on alloy sheath are available. Application conditions such as vibration and toxic/flammable media should be taken into consideration when installing heaters. Protective coatings are available for use on steel finned heaters for mildly corrosive or high humidity applications.

Finned tubular elements are safer to operate than open coil heaters as the risk of fire from combustible particles in the flow stream and electrical shock is minimized. Increased service life and less maintenance required due to the rugged finned element construction. Power loading (w/in) of finned tubulars can be matched to any open coil installation. Pressure drop when using finned elements will be slightly more than with open coil but normally not enough to matter. It varies with flow velocity ranging from .04"H₂O at 500 fpm to about .30"H₂O at 1500 fpm when elements are banked together in several rows for duct heaters.

- * Type T Post terminals standard. .315 dia. heaters have 8-32 threads and 10-32 threads are used on .430 & .475 dia. heaters. Full selection of tubular terminations available See page 10-4.
- * Catalog units have V2A silicon resin seals as standard. Most all other tubular seal options available. See page 10-16C.
- * Numerous factory bending formations available. Supply Tempco with dimensional sketch, drawing, or photo. See page 10-9.
- * Bright annealed, Nickel plating, Hi-heat aluminum, or Hi-heat flat black finishes available Furnace brazed Stainless Steel fins available as an option.
- * U2 & M2 formations are ideal for duct heating applications
- * Unfinned sections in bends or straight lengths of heated area can be provided on heaters up to 32wsi sheath watt density.
- * Catalog listed Steel heaters are UL recognized for use up to 750°F sheath temperature & Stainless construction up to 1000°F at a maximum of 85 wsi on sheath.

The finned tubular elements are normally used in forced or free convective air applications at low to medium temperatures. Typical applications are for heating indoor clean air from ambient conditions up to 250/275°F for steel finned units & 550°F for stainless fins. Steel finned heaters can be operated up to 750°F on sheath and stainless steel finned heaters used up to 1200°F (1000°F UL limit) sheath temperatures. Nominal sheath watt density and recommended operating conditions for the cataloged heaters are included in the table headings & footnotes. Lower airflows will require lower watt density ratings. Consideration should be given to using un-finned alloy sheath tubular elements for heating to higher outlet air temperatures or if operating in higher ambient air. Application conditions of flow velocity and inlet/outlet temperatures will govern sheath watt density to be used. The airflow graphs and examples presented will help with determining proper heater watt density. The cataloged designs are suitable for most low temperature applications that will be encountered.



Finned Tubular Heaters are UL recognized and CSA certified up to 85W/in² and 750°F for Steel sheath/steel finned and .85W/in² and 1000°F for Alloy or SS sheath/SS finned. The UL File Number is E65652 (CCN KSOT2/KSOT8).

If you require UL, CSA, or other NRTL agency approvals, please specify when ordering.

Typical Applications

- ➔ Convective air & gas heating in ducts
- ➔ Load resistor banks
- ➔ Moisture removal (dehumidification)
- ➔ Curing ovens & plastics dryers
- ➔ Low/medium temperature heat treating
- ➔ Convection ovens for food preparation
- ➔ Exhaust gas heating
- ➔ Forced air electric heaters
- ➔ Heat pump auxiliary systems
- ➔ Return air heating
- ➔ Inert Industrial process gas heating
- ➔ Organic Resins & Paint curing, baking & drying
- ➔ Autoclaves
- ➔ Film & ink drying
- ➔ Hopper heating
- ➔ Chemical processing & core drying
- ➔ Food Roasting & baking
- ➔ Textile & Varnish drying
- ➔ Heating for rail & marine applications

TUBULAR ELEMENT SIZES & MATERIALS

Sheath Diameter: .315", .375", .430" and .475"

Sheath Material: Steel, 304L SS, 316L SS, Incoloy 840 and Incoloy 800

Sheath Lengths: 12" to 196" depending on sheath diameter

Sheath Material Selection

Standard steel finned heaters are ideal for use in low temperature clean air applications not containing toxic contaminants or high humidity. When coated with one of the optional coatings available they are suitable for high humidity, organic vapors, or mildly corrosive applications. Stainless steel finned heaters should be employed for higher temperature uses or if the air/gas contains vapors known to be corrosive to steel. Optional nickel plated heaters can also be provided.

PERFORMANCE RATINGS

Maximum Temperature:

Steel fins on steel sheath—750°F (400°C)

Steel fins on Incoloy or SS sheath—750°F (400°C)

Stainless Steel fins on stainless, Incoloy 840 or Incoloy 800 sheath—1200°F (650°C)

Maximum Element Power Density Limits:

.315 dia.—84 watts/linear inch

.375 dia.—100 watts/linear inch

.430 dia.—115 watts/linear inch

.475 dia.—127 watts/linear inch

These values are for heaters with 3/8" fins at 4.5-5 fins/inch.

De-rate to 83% for heaters with 5/16" fins or that have less than 4.5 fins/inch.

ELECTRICAL RATINGS

Maximum Voltage: Up to 600VAC (480V for UL)

Resistance Tolerance: +10%, -5%

Wattage Tolerance: +5%, -10%

Sheath watt density range: 20-85 wsi (2-13 w/cm²), @ 4.5-5 fins/in

OPTIONAL FEATURES

Bulkhead Fittings: Brazed brass are standard. Welded or brazed Steel & SS optional. UNF threads standard, metric or special threads available.

Custom mounting brackets: (type MF or special). Dimensional sketch or drawing needed with material specs.

Locator washer: (type LC) specify location

Adjustable mounting collar: (type MC) w/set screw

Full selection of tubular termination options: Bulkhead fittings & type T post terminals standard.

Moisture Seals: V2A Silicon resin seal standard

SPECIFICATIONS AND PHYSICAL SIZE OF FINNS

Fin Materials and Attachment Method:

Steel & 304 SS

Steel wound with copper wire between fins for oven brazing to sheath. Stainless steel is mechanically wound but can be oven brazed as an option if a bright annealing atmosphere is used.

Fin Strip Width:

5/16" on .315, .375 and .430 diameters

3/8" on .315, .375 .430 and .475 diameters

Fin Thickness:

26 Ga. (.018) for Steel and 304 SS. Optional 24 Ga. (.024) for steel only

Finned OD's:

.315" dia. with 5/16" fins— .92" OD

.315" dia. with 3/8" fins—1.05" OD

.375" dia. with 5/16" fins— .98" OD

.375" dia. with 3/8" fins—1.11" OD

.430" dia. with 5/16" fins—1.04" OD

.430" dia. with 3/8" steel fins—1.15" OD, SS fins 1.16" OD

.475" dia. with 3/8" fins—1.21" OD

Fin Pitch Standards:

5±.5 for 5/16 material, 4.5-5 for 3/8 material (up to 6 per inch maximum)

SURFACE FINISHES

Oven brazed steel finned units - standard

Copper brazed stainless steel fins using inert atmosphere - special

Bright annealed steel or stainless steel finned heaters

High heat aluminum painted steel — 700°F Maximum

High heat flat black painted surface — 1000°F Maximum

Nickel plated finish — 500°F Maximum

FORMING LIMITATIONS

Minimum Element Centerline Bend Radius:

.315" dia. with 5/16" fins 3/4"

.315" dia. with 3/8" fins 7/8"

.375" dia. with 5/16" fins 7/8"

.375" dia. with 3/8" fins 1.00"

.430" dia. with 5/16" fins 1.00"

.430" dia. with 3/8" fins 1.00"

.475" dia. with 3/8" fins 1.00"

The above values are for factory formed heaters. Consult Tempco for field bending limits.

Tubular Heaters



Finned Tubular Heaters

Fitting Attachment Method — General Guidelines

These are guidelines only. Consult Tempco if you require assistance in determining the method best suited to your application.

Fittings Crimped: Low pressure water (up to 80 psig) and non-pressure air applications

Fittings Brazed: Non-ferrous alloys (copper) and dissimilar non-weldable metals

Fittings Welded: High pressure liquids and gases, and high temperature applications

Standard Bulkhead Fittings For Tubular Heaters — Round Flanged Standard

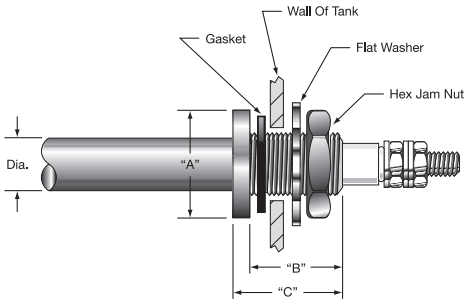

Tubular Diameter		Fitting Material	Flange Type	"A"		"B"		"C"		Thread Size (UNF)
in	mm			in	mm	in	mm	in	mm	
.315	8.0	Brass	Round	3/4	19	1/2	12.7	5/8	16	1/2-20
.315	8.0	Stn. Stl.	Round	3/4	19	1/2	12.7	5/8	16	1/2-20
.375	9.5	Brass	Round	3/4	19	1/2	12.7	5/8	16	1/2-20
.375	9.5	Stn. Stl.	Round	3/4	19	1/2	12.7	5/8	16	1/2-20
.430	10.9	Brass	Round or Hex	7/8	22	3/4	19.0	7/8	22	5/8-18
.430	10.9	Stn. Stl.	Round or Hex	7/8	22	3/4	19.0	7/8	22	5/8-18
.430	10.9	Steel	Round	7/8	22	3/4	19.0	7/8	22	5/8-18
.475	12.1	Brass	Round	7/8	22	3/4	19.0	7/8	22	5/8-18
.475	12.1	Stn. Stl.	Round	7/8	22	3/4	19.0	7/8	22	5/8-18
.475	12.1	Steel	Round	7/8	22	3/4	19.0	7/8	22	5/8-18
.475	12.1	Brass	Round	1	25	3/4	19.0	7/8	22	3/4-16
.475	12.1	Stn. Stl.	Round	1	25	3/4	19.0	7/8	22	3/4-16
.625	15.9	Stn. Stl.	Round	1-1/8	29	3/4	19.0	1	25	7/8-14



Note: Optional Larger Thread Sizes and Hex Flanged Bulkhead Fittings are available. Consult Tempco with your requirements.

Tubular Heater Standard Mounting Methods

Part Number	For Element Diameter		"A" Thick		"B" OD	
	in	mm	in	mm	in	mm
FAS-108-102	.315	8.0	5/16	7.9	5/8	15.9
FAS-108-103	.375	9.5	3/8	9.5	3/4	19.1
FAS-108-104	.430	10.9	7/16	11.1	7/8	22.2
FAS-108-106	.475	12.0	7/16	11.1	1	25.4

TYPE MC — Mounting Collar

Plated steel mounting collars are locked in place with a set-screw and serve as an adjustable stop for through-the-wall mounting. Collars are shipped in bulk unless otherwise specified. Mounting collars can be ordered with the heater or purchased separately.

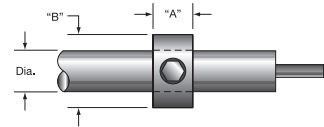

TYPE LR — Locator Washer

Locator washers are permanently attached to the heater sheath by staking/crimping and are used to limit the movement of the heater while allowing for expansion and contraction of the heater sheath. When ordering, specify location from end of sheath.

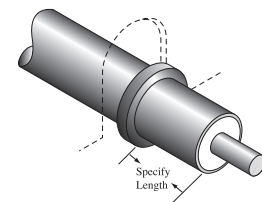

TYPE MF — Mounting Bracket

Tempco's made-to-order mounting brackets are made from 18 gauge stainless steel for strength and stiffness. It is an economical way to mount the heater in non-pressurizing, non-liquid applications. Unless otherwise specified, the bracket will be located 1/2" from the edge of the heater sheath. OEM quantity brackets are manufactured by Tempco on our own high speed precision N/C Turret Press. The standard method of attaching the tubular element to the bracket is staking or crimping.

The rectangular mounting bracket shown at right is a popular made-to-order design. Specify all dimensions shown when requesting a quote.

Custom brackets of any size, thickness or material can be supplied to meet your requirements.

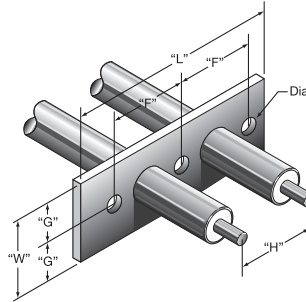

Tubular Heater Standard Moisture Seals

Magnesium Oxide (MgO) is used as the insulating material in Tempco tubular heaters because of its excellent thermal conductivity and dielectric strength. However, MgO is hygroscopic and can absorb moisture from the atmosphere. This absorption of moisture may be detected when an Insulation Resistance (IR) test is done with a megohmmeter prior to energizing the heater circuit. In very humid environments, circuits utilizing a GFI (ground fault interrupter) for safety may experience nuisance tripping when energizing the heater.

The Tempco manufacturing process produces a dry element with an IR of several thousand megohms minimum. However, after shipment and depending on humidity levels and storage time, a heater can absorb moisture and show a decrease in IR. In many cases, depending on the supply voltage and the application, the heater can be safely energized and will dry itself out.

If a heater has absorbed moisture, a safe and effective method of drying it out prior to installation is to bake it in an oven at 300°F (149°C) until an acceptable IR reading is obtained. When possible, removing the terminal hardware will expedite this process. If this method is not practical consult factory for other recommendations.

For applications where moisture absorption would be unacceptable Tempco has several optional element end seals to retard absorption of moisture in the MgO. If a true hermetic seal is required, ceramic to metal end seals (Type H) are available. With any of these seals, the maximum recommended termination temperature in the seal area must not be exceeded.

Style SS—Silicone Resin Seal

A brushed-on coating that penetrates the MgO, offering economical moisture protection under humid storage conditions.

Maximum Usable Termination Temperature: 390°F (200°C)

UL Rated Maximum Termination Temperature: 221°F (105°C)

Type V2A: conformal coating

Type V2B: silicone oil

Style SER—RTV Seal

RTV (room temperature vulcanizing) silicone rubber adhesive sealant provides a good moisture seal.

UL Rated – Maximum Termination Temperature:

Type R: 302°F (150°C)

Type R1: 392°F (200°C)

Style SEH—Epoxy Resin Seal

Epoxy resin provides a moisture resisting barrier.

UL Rated – Maximum Termination Temperature:

Type V: 194°F (90°C)

Type V1: 266°F (130°C)

Type V4: 392°F (200°C)

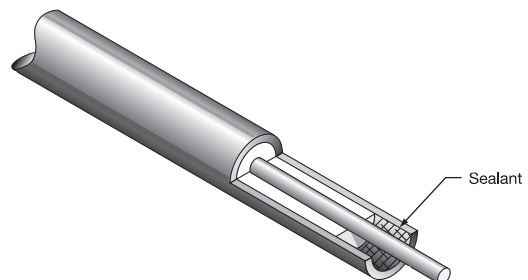

Finned Tubular Heaters

Design Guidelines

The major factors that need to be considered when specifying THF finned tubular heaters are as follows:

- Minimum FPM airflow velocity at heater inlet. Is it continuous or fluctuating
- Inlet air temperature
- Outlet air temperature and temperature rise through heating elements
- Selection of element watt density to keep sheath material within its temperature limits
- Sheath material selection
- Condition of air or gas to be heated
- Mounting & airflow restrictions around elements
- KW sizing and # of circuits required (48 amp max/circuit)
- Temperature sensors & flow controls

Heater KW Sizing

Once the inlet temperature, outlet temperature, process CFM, and operating pressure are known, the KW required for the application can be determined using the following equations. If the process is heating air & operating from ambient temperature and atmospheric pressure (70° +/- 10°F & 14.7 psi), the following formula can be used;

$$KW = \{[SCFM \times (T2-T1)] \div 3190\} + S.F.$$

Where:

T2 = °F outlet temperature

T1 = °F inlet temperature

SCFM = standard air flow in cu.ft./min. at atmospheric pressure and ambient temperature

S.F. = safety factor % to account for process losses

Converting CFM to SCFM

If the air heating process is pressurized or operating at an inlet temperature other than at or near ambient, the CFM at a point in the process with a known pressure & temperature must be used & converted to standard SCFM by the following formula;

$$SCFM = 35.4 \times CFM_2 \times \{(P_2+14.7) \div (T_2 + 460)\}$$

Where CFM₂ is cu.ft./min. air flow at process pressure P₂.

P₂ = process pressure (psig)

T₂ = inlet °F or temperature at point of measured CFM₂

Using the SCFM and the heater face flow area we can now calculate the air velocity in SFPM into the heater core as follows;

$$SFPM = SCFM \div A1$$

SFPM = inlet air velocity at standard conditions.

A1 = Sq.Ft. of inlet flow area at heater

An alternate method for calculating KW needed to heat air or other gas, from any inlet to outlet temperature can be done using the following general energy equation;

$$KW = \{[60 \text{ min/hr} \times SCFM \times \text{Density} \times \text{Sp Ht} \times \Delta T] \div 3412\} + S.F.$$

Where:

SCFM = standard air flow in cubic feet/min (@ 70°F & 14.7 psia)

Density = Gas density in lbs/cuft at standard conditions or if pressurized process at process pressure and inlet temperature. (see table)

Sp Ht = Specific heat of gas in Btu/lb-°F at standard conditions or if pressurized process at process pressure and inlet temperature. (values for air are shown in the gas density table)

ΔT = Process gas temperature rise -°F

3412 = conversion factor for Btu/hr to KW (1 KW = 3412 Btu/hr)

S.F. = safety factor % to account for process losses.

Using the inlet air velocity at the heater and the maximum outlet temperature desired the maximum sheath watt density can now be determined from the following charts for the type of heater being specified if a cataloged design is not suitable. The physical size and constraints of the application will dictate the final configuration and number of heaters required. For large installations, 3 phase circuits need to be balanced and all circuits limited no more than 48 amps per circuit. If voltages are higher than 250V, .375, .430, or .475 diameter elements are recommended.

Sheath Watt Density

The maximum sheath watt density to be specified is directly determined by the operating variables of FPM airflow velocity and inlet/outlet air/gas temperatures required. It must be selected such that sheath operating temperatures are not exceeded; 750°F for steel sheath-steel finned, or 1200°F for stainless steel/alloy sheath with stainless fins. Cataloged heaters are designed to operate within these parameters. The following charts will help guide the user in selecting proper watt density.

Allowable Sheath Watts/Square Inch at Various Air Velocities for Steel or Stainless Steel Finned THF heaters

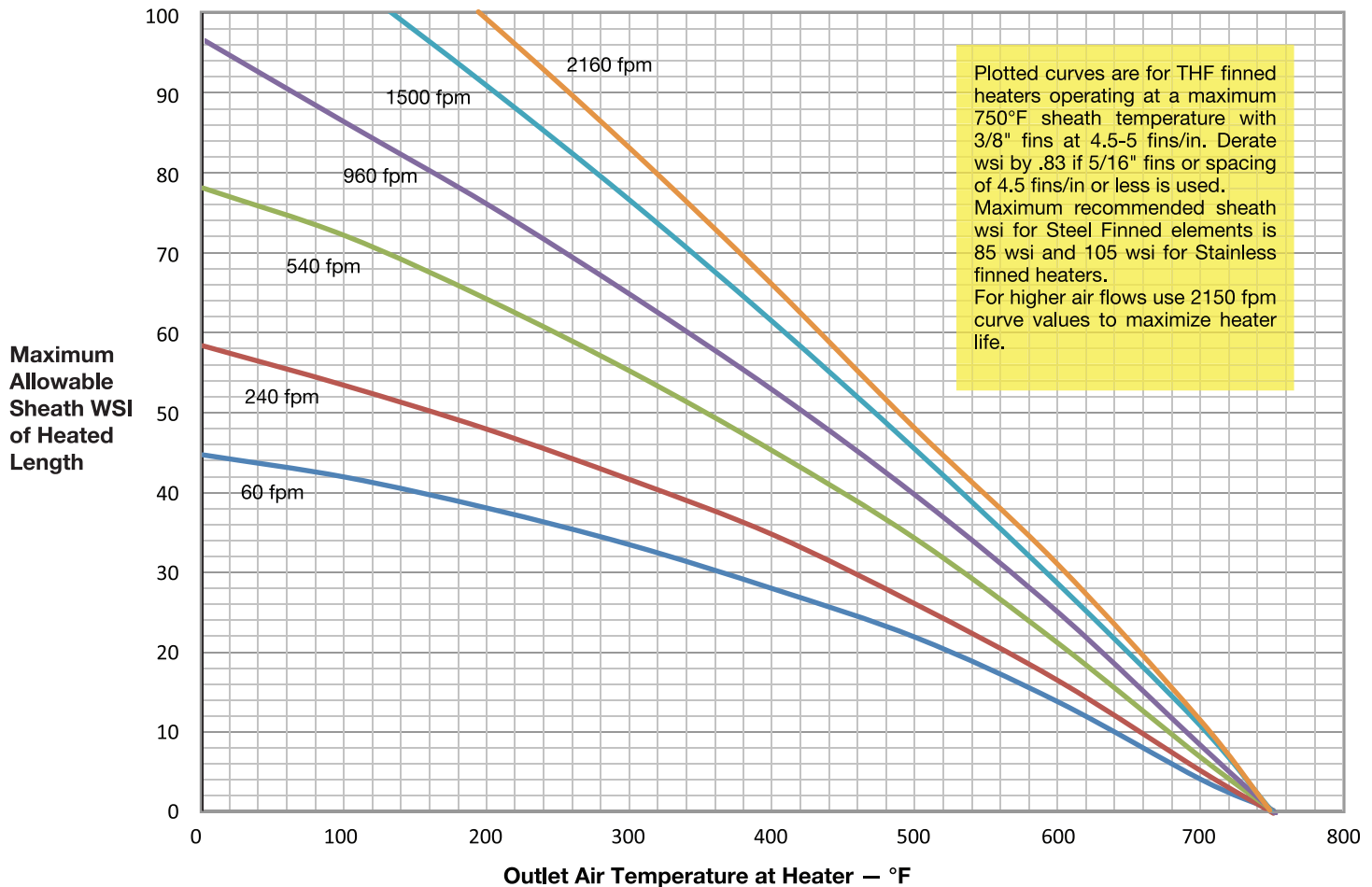

Chart 1 for steel (or SS) finned elements relates the maximum allowable sheath wsi to outlet air temperature that will be obtained at various air velocity levels.

These curves are for 750°F (or lower) sheath operating temperature.

The following Examples Illustrate the Graph's Use

Example 1

An application requires a heater to output 275°F air at an air velocity of 750 FPM. Entering the curves with 275°F, then up to 750 FPM level we find that a maximum of 62-64 wsi can be applied. Depending on voltage and space constraints either a .315 or .430 diameter catalog heater could be used.

Example 2

A curing oven needed 325°F outlet air at a minimum velocity of 1500 FPM. Entering chart at 325°F up to the 1500 FPM curve, we see that the heater could have a maximum of 70-72 sheath wsi. If a higher outlet air temperature is required, or if the airflow velocity is lower, then a reduced a sheath wsi would have to be specified.

Air Outlet Temperature vs Air Velocity
for various THF Sheath WSI Levels

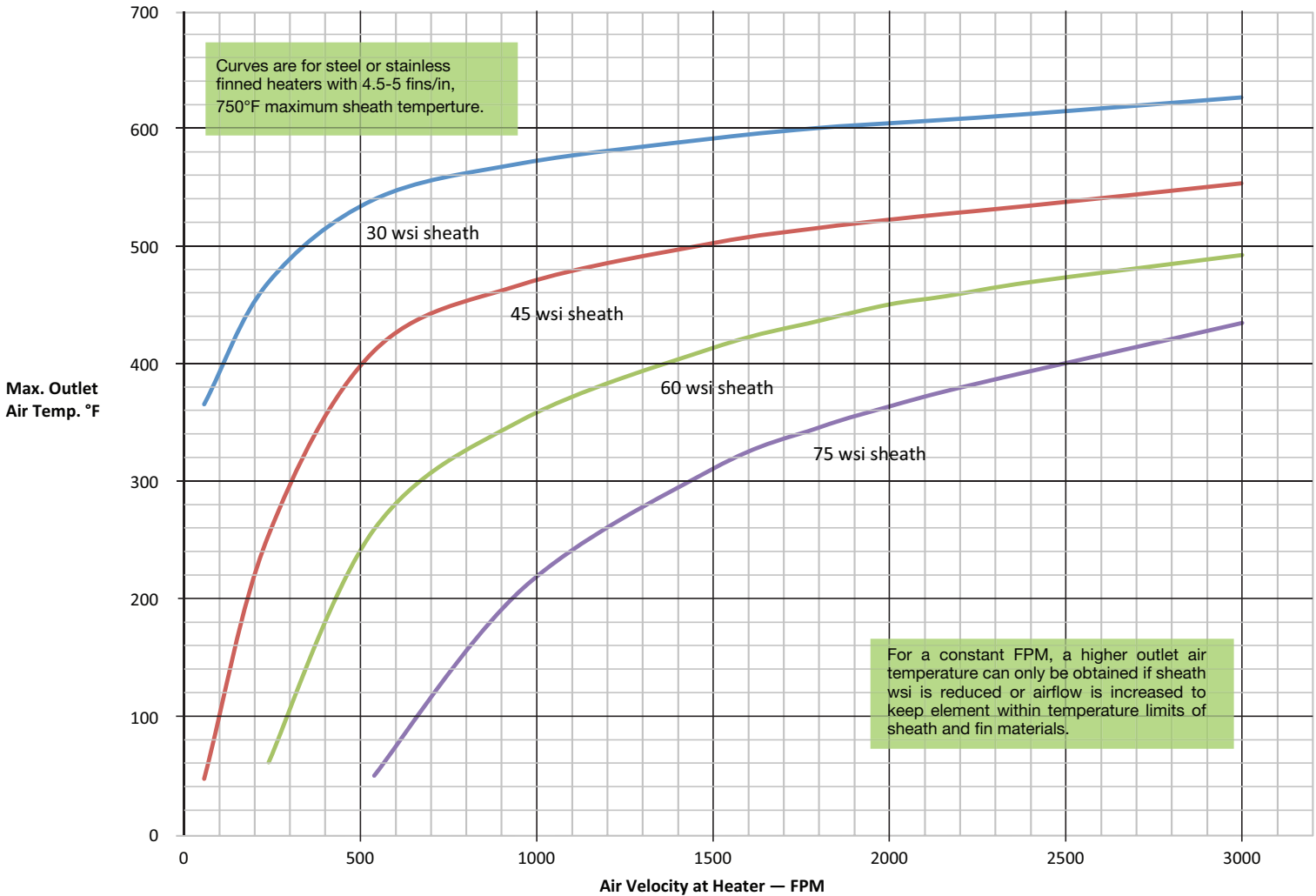

Chart 2 shows the relationship of maximum outlet air temperature obtained vs inlet air velocity at several sheath wsi levels.

This chart can be used for either steel or stainless steel finned elements operating at a maximum of 750°F and provides a way of establishing either airflow required or outlet temperature that will be obtained when sheath wsi is known for an application.

These curves show that to obtain a higher air outlet temperature at a constant FPM, the sheath wsi must be reduced to keep the element within the 750°F temperature limit of sheath & fin materials. These curves are for air entering a heater at or near ambient (60°-105°F).

**Sheath Temperature vs wsi for THF Finned Tubular Elements
in various velocities of forced air at 80°F**

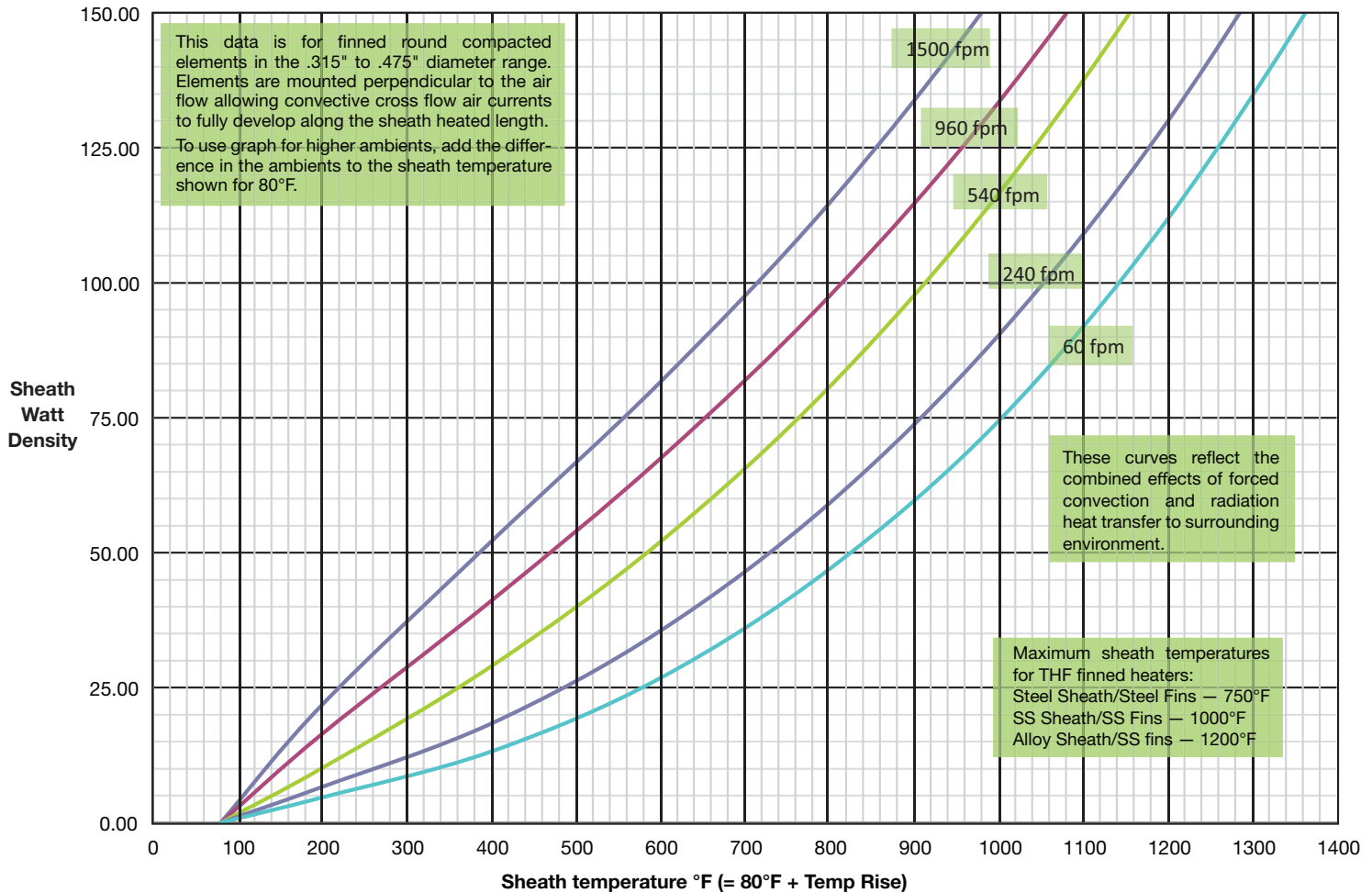

Chart 3 is a plot of sheath temperature and sheath watt density at various levels of inlet forced air at 80°F

It can be used to determine a maximum allowable sheath wsi for heating applications not restricted to the steel sheath limit of 750°. It can be used directly for most ambient air heating processes using Incoloy or Stainless Steel sheathed elements with stainless steel fins.

The following Example Illustrates the Graph's use when Operating in a Higher Ambient

Application

A recirculating process oven with organic vapors, moisture & other air contamination present, requires 500°F air at a minimum flow velocity of 900 FPM. Can a Stainless steel finned alloy sheathed heater at 80 wsi be used?

Using the Graph

Entering this chart at 900 FPM and 80 wsi, we find the sheath temperature when operating at 80°F ambient will be 700°F. The ambient temperature difference from the graph value of 80°F to the new higher 500°F ambient is 420°F (500-80). The new sheath temperature when operating in the 500°F ambient will be approximately 1120°F. (700 + 420). This is just 80° lower than the 1200°F limit for a stainless steel finned heater.

To conserve heater life it would be best to use a lower watt density & operate the heater at the lowest point possible given voltage, size, and construction constraints of the application. Consideration should be given to increasing the air velocity or using un-finned alloy sheath tubular heaters for this application. (See page 11-104)

Tech note: The reverse is true if element is operating in an ambient lower than 80°F. The sheath temperature would be reduced by the difference in the temperatures. The WSI range shown on the chart is approximately 4.25 times an unfinned tubular. The data has been confirmed by Tempco lab testing on .430 & .475 diameter finned heaters with 4.5-5 fins/in.

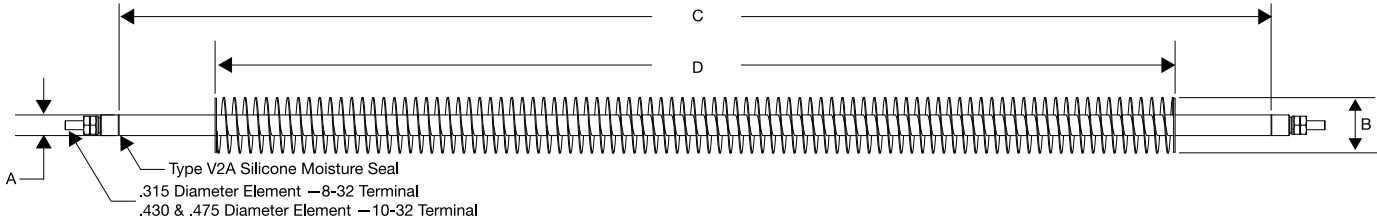

Standard (Non-Stock) Sizes and Ratings with Type T Termination

62-64 Sheath Watt Density (wsi)

Element Description	Dim. "A" inches	Dim. "B" inches	Dim. "C" inches	Dim. "D" inches	Watts	Part Number				
						120V	208V	240V	277V	480V
.315 Dia. Steel Element 5/16 Brazed Steel Fins 60 W/in	.315	.92	12½	8½	500	THF00321	—	—	—	—
	.315	.92	17½	13½	750	THF00322	THF00323	THF00324	—	—
	.315	.92	20½	16½	1000	THE00325	THF00326	THF00327	—	—
	.315	.92	29	25	1500	THF00328	THF00329	THF00330	—	—
	.315	.92	37	33	2000	THF00331	THF00332	THF00333	—	—
	.315	.92	54	50	3000	—	THF00334	THF00335	—	—
.430 Dia. Steel Element 3/8 Brazed Steel Fins 80 W/in	.430	1.15	17	13	1000	—	THF00338	THF00339	THF00340	THF00341
	.430	1.15	22¾	18¾	1500	—	THF00342	THF00343	THF00344	THF00345
	.430	1.15	29	25	2000	—	THF00346	THF00347	THF00348	THF00349
	.430	1.15	41	37	3000	—	THF00350	THF00351	THF00352	THF00353
	.430	1.15	53	49	4000	—	THF00354	THF00355	THF00356	THF00357
	.430	1.15	65	61	5000	—	THF00358	THF00359	THF00360	THF00361
.475 Dia. SS Element 3/8 SS Fins 90 W/in	.475	1.21	21½	17½	1500	—	THF00366	THF00367	THF00368	THF00369
	.475	1.21	26½	22½	2000	—	THF00370	THF00371	THF00372	THF00373
	.475	1.21	37	33	3000	—	THF00374	THF00375	THF00376	THF00377
	.475	1.21	48	44	4000	—	THF00378	THF00379	THF00380	THF00381
	.475	1.21	59	55	5000	—	THF00382	THF00383	THF00384	THF00385
	.475	1.21	70	66	6000	—	THF00386	THF00387	THF00388	THF00389
	.475	1.21	81	77	7000	—	THF00390	THF00391	THF00392	THF00393
	.475	1.21	92	88	8000	—	THF00394	THF00395	THF00396	THF00397

.315 diameter elements are typically used for air heating from ambient to 250/275°F at a minimum airflow of 700 FPM.

Maximum sheath temperature is 750°F. Reduced sheath watt density (wsi) required for lower airflows.

.430 diameter elements are typically used for air heating from ambient to 275/300°F at a minimum airflow of 750 FPM.

Maximum sheath temperature is 750°F. Reduced sheath watt density (wsi) required for lower airflows.

.475 diameter elements are typically used for air heating from ambient to 450/500°F at a minimum airflow of 1400 FPM.

Maximum sheath temperature is 1200°F. Reduced sheath watt density (wsi) required for lower airflows.

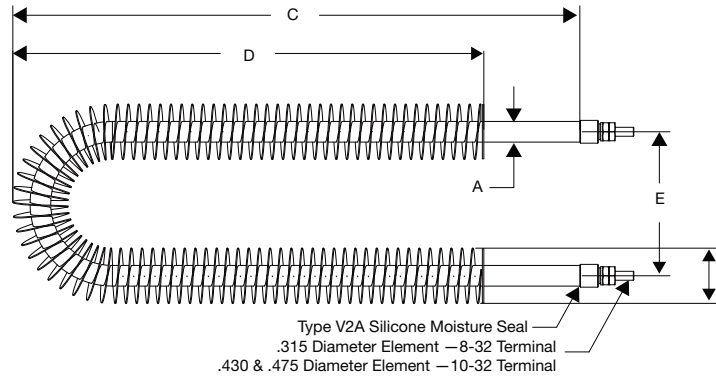

Standard (Non-Stock) Sizes and Ratings with Type T Termination
 62-64 Sheath Watt Density (wsi)

Element Description	Dim. "A" inches	Dim. "B" inches	Dim. "C" inches	Dim. "D" inches	Dim. "E" inches	Watts	Part Number				
							120V	208V	240V	277V	480V
.315 Dia. Steel Element 5/16 Brazed Steel Fins 60 W/in	.315	.92	8¾	6¾	2	750	THF00398	THF00399	THF00400	—	—
	.315	.92	10¾	8¾	2	1000	THF00401	THF00402	THF00403	—	—
	.315	.92	14¾	12¾	2	1500	THE00404	THF00405	THF00406	—	—
	.315	.92	18½	16½	2	2000	THF00407	THF00408	THF00409	—	—
	.315	.92	26½	24½	2	3000	THF00410	THF00411	THF00412	—	—
	.315	.92	34½	32½	2	4000	—	THF00414	THF00415	—	—
.430 Dia. Steel Element 3/8 Brazed Steel Fins 80 W/in	.430	1.15	8½	6½	2	1000	—	THF00419	THF00420	THF00421	THF00422
	.430	1.15	11½	9½	2	1500	—	THF00423	THF00424	THF00425	THF00426
	.430	1.15	14½	12½	2	2000	—	THF00427	THF00428	THF00429	THF00430
	.430	1.15	21	19	2	3000	—	THF00431	THF00432	THF00433	THF00434
	.430	1.15	27	25	2	4000	—	THF00435	THF00436	THF00437	THF00438
	.430	1.15	32½	31	2	5000	—	THF00439	THF00440	THF00441	THF00442
.475 Dia. SS Element 3/8 SS Fins 90 W/in	.475	1.21	10½	8½	2½	1500	—	THF00447	THF00448	THF00449	THF00450
	.475	1.21	13¼	11¼	2½	2000	—	THF00451	THF00452	THF00453	THF00454
	.475	1.21	18½	16½	2½	3000	—	THF00455	THF00456	THF00457	THF00458
	.475	1.21	24	22	2½	4000	—	THF00459	THF00460	THF00461	THF00462
	.475	1.21	29½	27½	2½	5000	—	THF00463	THF00464	THF00465	THF00466
	.475	1.21	35	33	2½	6000	—	THF00467	THF00468	THF00469	THF00470
	.475	1.21	40½	38½	2½	7000	—	THF00471	THF00472	THF00473	THF00474
	.475	1.21	46	44	2½	8000	—	—	THF00475	THF00476	THF00477

.315 diameter elements are typically used for air heating from ambient to 250/275°F at a minimum airflow of 700 FPM.

Maximum sheath temperature is 750°F. Reduced sheath watt density (wsi) required for lower airflows

.430 diameter elements are typically used for air heating from ambient to 275/300°F at a minimum airflow of 750 FPM.

Maximum sheath temperature is 750°F. Reduced sheath watt density (wsi) required for lower airflows.

.475 diameter elements are typically used for air heating from ambient to 450/500°F at a minimum airflow of 1400 FPM.

Maximum sheath temperature is 1200°F. Reduced sheath watt density (wsi) required for lower airflows.

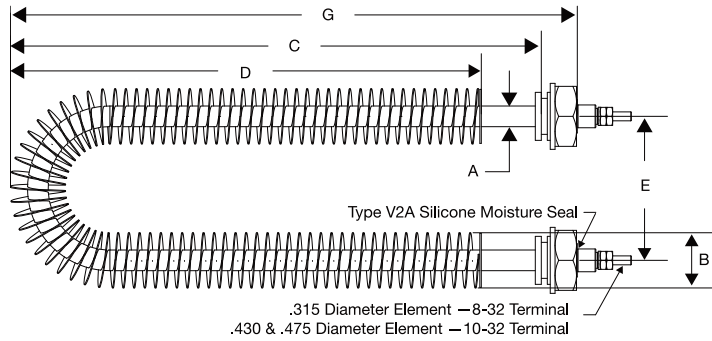

Standard (Non-Stock) Sizes and Ratings with Type T Termination 62-64 Sheath Watt Density (wsi)

Element Description	Dim. "A" inches	Dim. "B" inches	Dim. "C" inches	Dim. "D" inches	Dim. "E" inches	Dim. "G" inches	Watts	Part Number				
								120V	208V	240V	277V	480V
.315 Dia. Steel Element 5/16 Brazed Steel Fins 60 W/in	.315	.92	8¼	6¼	2	8¼	750	THF00478	THF00479	THF00480	—	—
	.315	.92	10¼	8¼	2	10¾	1000	THF00481	THF00482	THF00483	—	—
	.315	.92	14¼	12¼	2	14¾	1500	THE00484	THF00485	THF00486	—	—
	.315	.92	18	16½	2	18½	2000	THF00487	THF00488	THF00489	—	—
	.315	.92	26	24½	2	26½	3000	THF00490	THF00491	THF00492	—	—
	.315	.92	34	32½	2	34½	4000	—	THF00493	THF00494	—	—
	.315	.92	42½	41	2	43	5000	—	THF00495	THF00496	—	—
.430 Dia. Steel Element 3/8 Brazed Steel Fins 80 W/in	.430	1.15	7¾	6½	2	8½	1000	—	THF00497	THF00498	THF00499	THF00500
	.430	1.15	10¾	9½	2	11½	1500	—	THF00501	THF00502	THF00503	THF00504
	.430	1.15	13¾	12½	2	14½	2000	—	THF00505	THF00506	THF00507	THF00508
	.430	1.15	20¼	19	2	21	3000	—	THF00509	THF00510	THF00511	THF00512
	.430	1.15	26¼	25	2	27	4000	—	THF00513	THF00514	THF00515	THF00516
	.430	1.15	32¼	31	2	33	5000	—	THF00517	THF00518	THF00519	THF00520
	.430	1.15	38¾	37½	2	39½	6000	—	THF00521	THF00522	THF00523	THF00524
.475 Dia. SS Element 3/8 SS Fins 90 W/in	.475	1.21	9¾	8½	2½	10½	1500	—	THF00525	THF00526	THF00527	THF00528
	.475	1.21	12½	11¼	2½	13¼	2000	—	THF00529	THF00530	THF00531	THF00532
	.475	1.21	17¾	16½	2½	18½	3000	—	THF00533	THF00534	THF00535	THF00536
	.475	1.21	23¼	22	2½	24	4000	—	THF00537	THF00538	THF00539	THF00540
	.475	1.21	28¾	27½	2½	29½	5000	—	THF00541	THF00542	THF00543	THF00544
	.475	1.21	34¼	33	2½	35	6000	—	THF00545	THF00546	THF00547	THF00548
	.475	1.21	39¾	38½	2½	40½	7000	—	THF00549	THF00550	THF00551	THF00552
	.475	1.21	45¼	44	2½	46	8000	—	—	THF00553	THF00554	THF00555

.315 diameter elements are typically used for air heating from ambient to 250/275°F at a minimum airflow of 700 FPM.

Maximum sheath temperature is 750°F. Reduced sheath watt density (wsi) required for lower airflows.

.430 diameter elements are typically used for air heating from ambient to 275/300°F at a minimum airflow of 750 FPM.

Maximum sheath temperature is 750°F. Reduced sheath watt density (wsi) required for lower airflows.

.475 diameter elements are typically used for air heating from ambient to 450/500°F at a minimum airflow of 1400 FPM.

Maximum sheath temperature is 1200°F. Reduced sheath watt density (wsi) required for lower airflows.

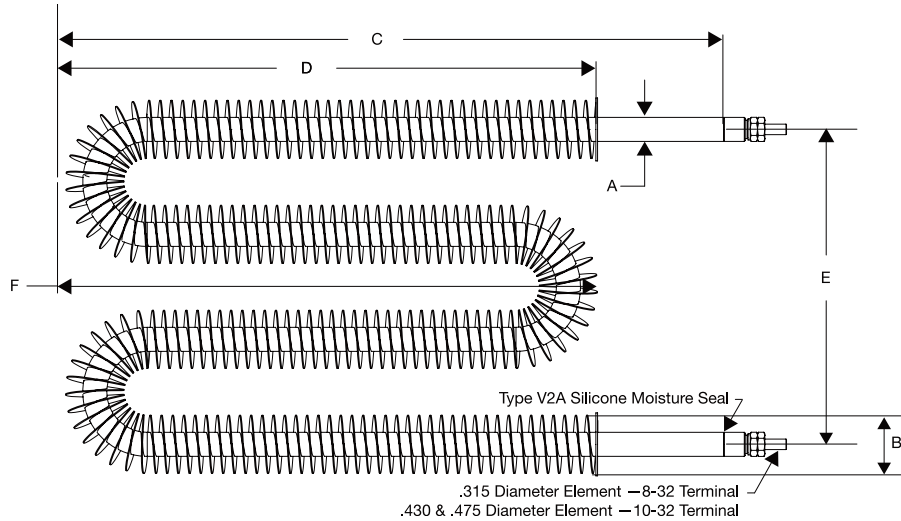

Standard (Non-Stock) Sizes and Ratings with Type T Termination

62-64 Sheath Watt Density (wsi)

Element Description	Dim. "A" inches	Dim. "B" inches	Dim. "C" inches	Dim. "D" inches	Dim. "E" inches	Dim. "F" inches	Watts	Part Number				
								120V	208V	240V	277V	480V
.315 Dia. Steel Element 5/16 Brazed Steel Fins 60 W/in	.315	.92	6¼	4¼	6	4¼	1000	THF00556	THF00557	THF00558	—	—
	.315	.92	8¼	6¼	6	6¼	1500	THF00559	THF00560	THF00561	—	—
	.315	.92	10¼	8¼	6	8¼	2000	THE00562	THF00563	THF00564	—	—
	.315	.92	14¼	12¼	6	12¼	3000	THF00565	THF00466	THF00567	—	—
	.315	.92	18¼	16¼	6	16¼	4000	THF00568	THF00569	THF00570	—	—
	.315	.92	22¼	20¼	6	20¼	5000	—	THF00571	THF00572	—	—
.430 Dia. Steel Element 3/8 Brazed Steel Fins 80 W/in	.430	1.15	8	6	7.5	6	2000	—	THF00575	THF00576	THF00577	THF00578
	.430	1.15	11	9	7.5	9	3000	—	THF00579	THF00580	THF00581	THF00582
	.430	1.15	14	12	7.5	12	4000	—	THF00583	THF00584	THF00585	THF00586
	.430	1.15	17	15	7.5	15	5000	—	THF00587	THF00588	THF00589	THF00590
	.430	1.15	20	18	7.5	18	6000	—	THF00591	THF00592	THF00593	THF00594
	.430	1.15	23	21	7.5	21	7000	—	THF00595	THF00596	THF00597	THF00598
.475 Dia. SS Element 3/8 SS Fins 90 W/in	.475	1.21	7½	5½	9	5½	2000	—	THF00602	THF00603	THF00604	THF00605
	.475	1.21	10	8	9	8	3000	—	THF00606	THF00607	THF00608	THF00609
	.475	1.21	12½	10½	9	10½	4000	—	THF00610	THF00611	THF00612	THF00613
	.475	1.21	15½	13½	9	13½	5000	—	THF00614	THF00615	THF00616	THF00617
	.475	1.21	18	16	9	16	6000	—	THF00618	THF00619	THF00620	THF00621
	.475	1.21	21	19	9	19	7000	—	THF00622	THF00623	THF00624	THF00625
	.475	1.21	24	22	9	22	8000	—	—	THF00626	THF00627	THF00628

.315 diameter elements are typically used for air heating from ambient to 250/275°F at a minimum airflow of 700 FPM.

Maximum sheath temperature is 750°F. Reduced sheath watt density (wsi) required for lower airflows

.430 diameter elements are typically used for air heating from ambient to 275/300°F at a minimum airflow of 750 FPM.

Maximum sheath temperature is 750°F. Reduced sheath watt density (wsi) required for lower airflows.

.475 diameter elements are typically used for air heating from ambient to 450/500°F at a minimum airflow of 1400 FPM.

Maximum sheath temperature is 1200°F. Reduced sheath watt density (wsi) required for lower airflows.

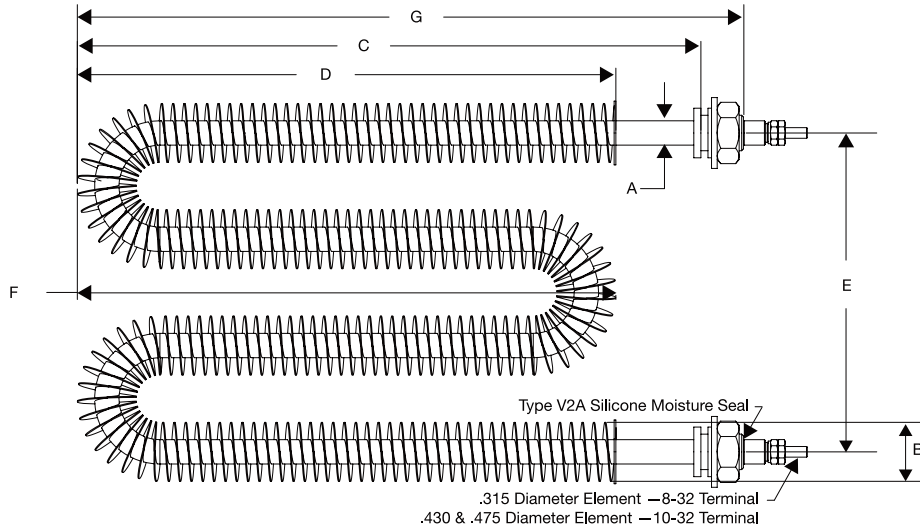

Standard (Non-Stock) Sizes and Ratings with Type T Termination 62-64 Sheath Watt Density (wsi)

Element Description	Dim. "A" inches	Dim. "B" inches	Dim. "C" inches	Dim. "D" inches	Dim. "E" inches	Dim. "F" inches	Dim. "G" inches	Watts	Part Number				
									120V	208V	240V	277V	480V
.315 Dia. Steel Element 5/16 Brazed Steel Fins 60 W/in	.315	.92	5 ³ / ₄	4 ¹ / ₄	6	4 ¹ / ₄	6 ¹ / ₄	1000	THF00629	THF00630	THF00631	—	—
	.315	.92	7 ³ / ₄	6 ¹ / ₄	6	6 ¹ / ₄	8 ¹ / ₄	1500	THF00632	THF00633	THF00634	—	—
	.315	.92	9 ³ / ₄	8 ¹ / ₄	6	8 ¹ / ₄	10 ¹ / ₄	2000	THF00635	THF00636	THF00637	—	—
	.315	.92	13 ³ / ₄	12 ¹ / ₄	6	12 ¹ / ₄	14 ¹ / ₄	3000	THF00638	THF00639	THF00640	—	—
	.315	.92	17 ³ / ₄	16 ¹ / ₄	6	16 ¹ / ₄	18 ¹ / ₄	4000	THF00641	THF00642	THF00643	—	—
	.315	.92	21 ³ / ₄	20 ¹ / ₄	6	20 ¹ / ₄	22 ¹ / ₄	5000	—	THF00644	THF00645	—	—
.430 Dia. Steel Element 3/8 Brazed Steel Fins 80 W/in	.430	1.15	7 ¹ / ₄	6	7.5	6	8	2000	—	THF00648	THF00649	THF00650	THF00651
	.430	1.15	10 ¹ / ₄	9	7.5	9	11	3000	—	THF00652	THF00653	THF00654	THF00655
	.430	1.15	13 ¹ / ₄	12	7.5	12	14	4000	—	THF00656	THF00657	THF00658	THF00659
	.430	1.15	16 ¹ / ₄	15	7.5	15	17	5000	—	THF00660	THF00661	THF00662	THF00663
	.430	1.15	19 ¹ / ₄	18	7.5	18	20	6000	—	THF00664	THF00665	THF00666	THF00667
	.430	1.15	22 ¹ / ₄	21	7.5	21	23	7000	—	THF00668	THF00669	THF00670	THF00671
.475 Dia. SS Element 3/8 SS Fins 90 W/in	.475	1.21	6 ³ / ₄	5 ¹ / ₂	9	5 ¹ / ₂	7 ¹ / ₂	2000	—	THF00675	THF00676	THF00677	THF00678
	.475	1.21	9 ¹ / ₄	8	9	8	10	3000	—	THF00679	THF00680	THF00681	THF00682
	.475	1.21	11 ³ / ₄	10 ¹ / ₂	9	10 ¹ / ₂	12 ¹ / ₂	4000	—	THF00683	THF00684	THF00685	THF00686
	.475	1.21	14 ³ / ₄	13 ¹ / ₂	9	13 ¹ / ₂	15 ¹ / ₂	5000	—	THF00687	THF00688	THF00689	THF00690
	.475	1.21	17 ¹ / ₄	16	9	16	18	6000	—	THF00691	THF00692	THF00693	THF00694
	.475	1.21	20 ¹ / ₄	19	9	19	21	7000	—	THF00695	THF00696	THF00697	THF00698
	.475	1.21	23 ¹ / ₄	22	9	22	8000	—	—	THF00699	THF00700	THF00701	THF00701

.315 diameter elements are typically used for air heating from ambient to 250/275°F at a minimum airflow of 700 FPM.

Maximum sheath temperature is 750°F. Reduced sheath watt density (wsi) required for lower airflows

.430 diameter elements are typically used for air heating from ambient to 275/300°F at a minimum airflow of 750 FPM.

Maximum sheath temperature is 750°F. Reduced sheath watt density (wsi) required for lower airflows.

.475 diameter elements are typically used for air heating from ambient to 450/500°F at a minimum airflow of 1400 FPM.

Maximum sheath temperature is 1200°F. Reduced sheath watt density (wsi) required for lower airflows.

Finned Duct Heaters can be found on Page 11-113A and 11-113B

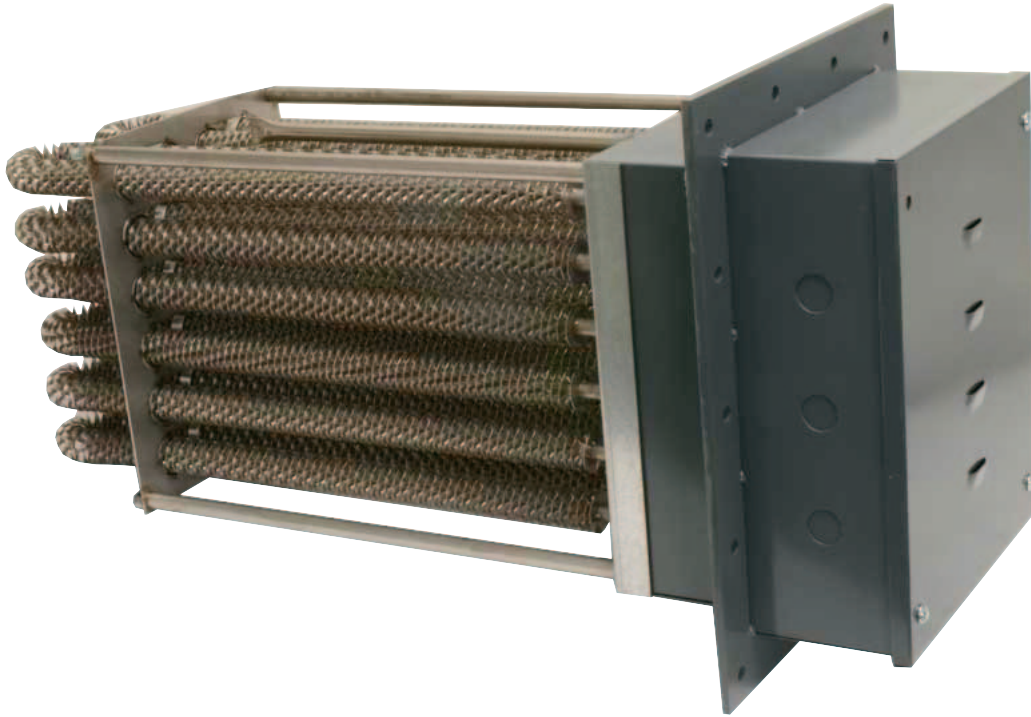



Single-Ended Tubular Heaters



The **Single-Ended Tubular Heater** manufacturing and design process is similar to that of the double ended tubular heater. Single ended tubular heaters are made strictly per customer request, providing an economical alternative to cartridge heater applications, simplifying wiring and installation for applications requiring localized heat. Flanges, bulkhead and NPT fittings can be attached to the sheath for mounting or immersion heating applications.

Specifications

Diameters: .315" .430" .475" .490" .625"

Material: 304SS, 316SS, Monel, Steel

Min. Sheath Length: 11" **Max. Sheath Length:** 96"

Termination: Lead Wires

Max. Volts: 277 Vac **Max. Amperage:** 30 Amp

Ordering Information Single-Ended Tubular Heaters

Please Specify the following:

- Sheath Material and Diameter
- Heater Length and Cold Ends
- Bulkhead Fittings
- Wattage and Voltage
- Terminations and Seals
- Mounting Flange

⚠ WARNING: Cancer and Reproductive Harm - www.P65Warnings.ca.gov.

The Tubular Heater — The Most Customizable Electric Heating Element



Type ART Tubular Radiant Heater Arrays



Tempco can design and manufacture a custom tubular heater array for applications requiring infrared heat. Call for details.

Other type infrared heaters can be found in Section 7.

Tubular Heaters



Quote Request

Tubular Heater, Finned Tubular Heater and Single Ended Tubular Heater Quote Request
Made-To-Order Quote Request Form – Copy and Fax (630-350-0232) us your requirements.

Customer Drawing

Name _____
Company _____
Address _____

Phone _____ Fax _____
Email _____

Application Information

Describe in Detail _____

Air or Immersion _____
Maximum Load Temperature _____
Quantity _____

Specifications

Type: Standard _____ Finned _____ Single Ended _____
Sheath Material _____
Diameter _____ Fin Dia. *if applies* _____
Overall Sheath Length _____
Cold Section: 1st end _____ 2nd end _____
Watts _____ Volts _____
UL _____ cUL _____ CSA _____ CE _____
Termination Type _____ (Type T – standard screw)

Standard Options

Mounting: MC ___ LR ___ Location: _____ MF ___
Bulkhead Fittings ___ Material ___ Flange Type ___
Describe if Custom _____

Moisture Seals

Moisture Seals: None _____
Optional: Style SS: Type V2A _____ Type V2B _____
Style SER: Type R _____ Type R1 _____
Style SEH: Type V _____ Type V1 _____
Type M _____ Type H _____
Describe if Custom _____

Optional Sheath Surface Treatments

(For Incoloy® and Stainless Steel Sheath Elements only)
Passivation _____ Bright Annealing _____
Electro-Polishing _____
Other _____

Bends and Shapes

Standard Formation Code _____
Specify Letters and Corresponding Dimensions Below:

Number of Bends *if known*
Single/Multiple _____ Plane _____
Coils/Turns _____ Dia. _____
Circle: Full ___ Dia. ___ Partial ___ Degree ___
Describe if Custom: _____

⚠ WARNING: Cancer and Reproductive Harm - www.P65Warnings.ca.gov.

View Product Inventory @ www.tempco.com

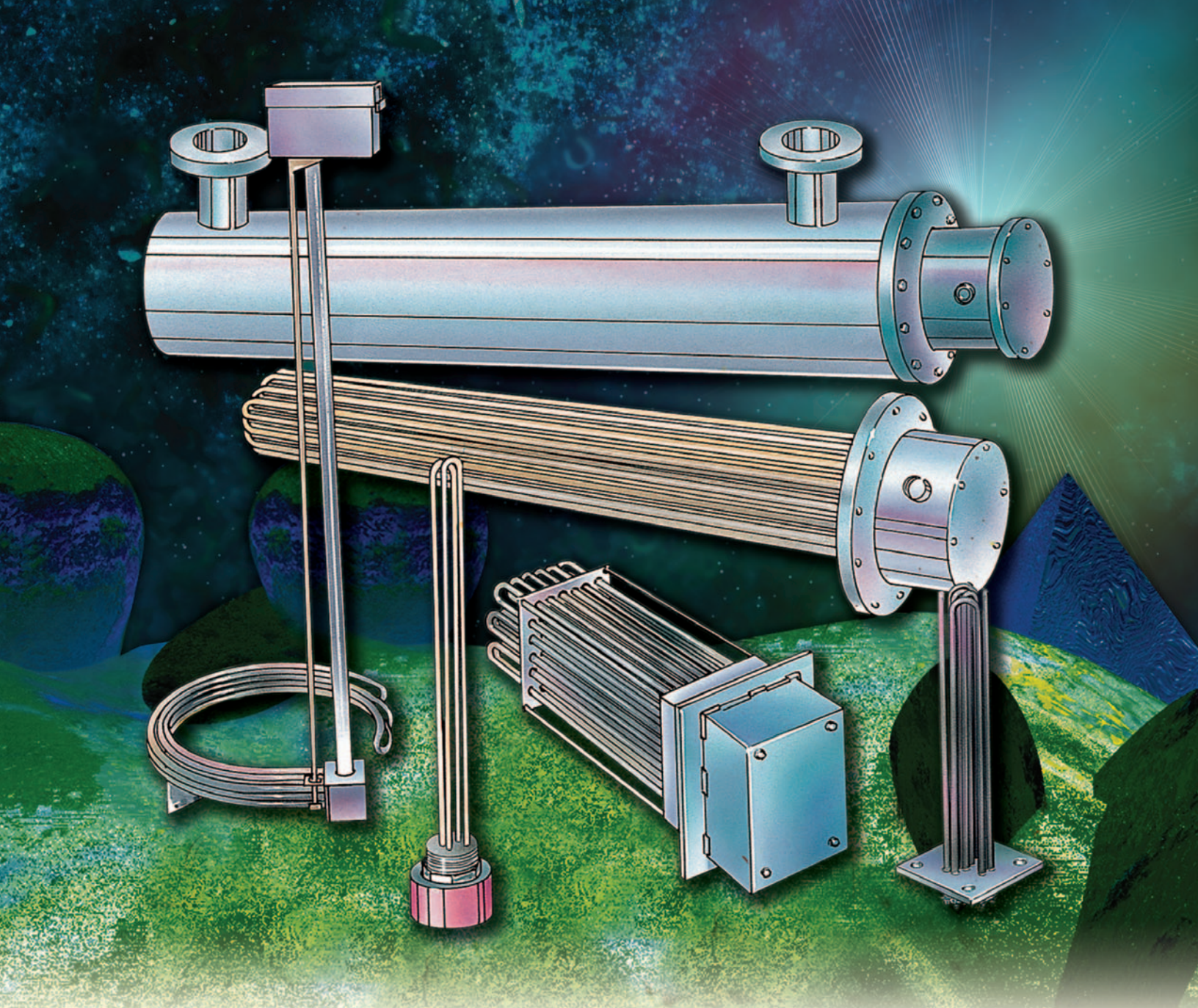

Table Of Contents

Pictorial Index	A-25	In-Line Forced Air Heaters	11-74
Screw Plug		Over-the-Side	
Immersion Heaters	11-2	Tank Immersion Heaters	11-78
Flanged Aluminum Finned		Deep Tank/Sump Immersion Heater	11-82
Immersion Heaters	11-20	Over-the-Side	
Flanged Immersion Heaters		Chemical Bath Immersion Heaters	11-84
OEM Replacements	11-22	Duct Heaters	11-104
Flanged Immersion Heaters		Enclosure Heaters	11-114
Pressure Rated	11-26	Heated Hose	11-116
Flanged Heater for Sanitary Processes ...	11-45	Drum Heaters	11-120
Circulation Heaters	11-46	Tote Tank Heaters	11-126
Circulation Heater Systems	11-71		

11

section

Process Heaters

Screw Plug Immersion Heaters

Screw Plug Immersion Heaters consist of tubular elements welded or brazed into a threaded screw plug which can then be inserted into a threaded opening in a tank wall or through a mating full or half coupling.

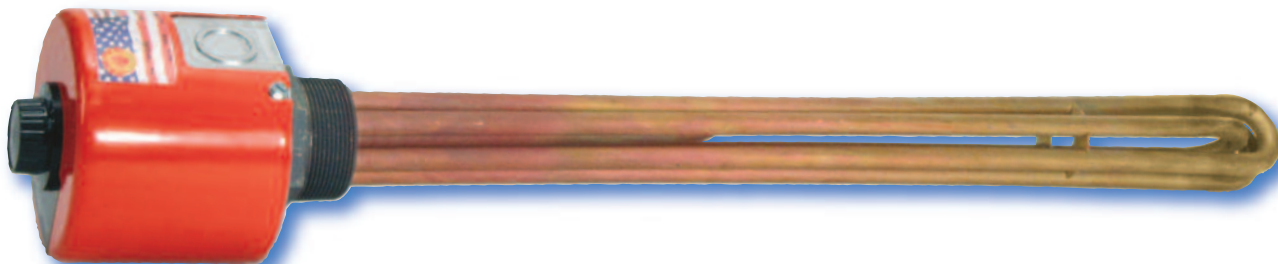

Design Features

- * *Stainless Steel, Brass or Steel Screw Plugs*
- * *Four Standard Screw Plug Sizes—1", 1-1/4", 2", 2-1/2"*
- * *Recompact element bends restore insulation resistance after forming*
- * *Thermowell for optional bulb & capillary thermostat, RTD or T/C probe*
- * *Corrosion-Resistant electrical wiring hardware*
- * *Four standard sheath materials — Copper, Steel, 316 Stainless Steel and Incoloy®800*
- * *NEMA 1 round terminal housing*
- * *Silicone resin element seal standard*

Optional Features

- * *NEMA 4 Moisture-Proof and/or NEMA 7 Explosion-Resistant terminal housings*
- * *Integral Single or Double Pole Thermostats in various temperature ranges to suit the application*
- * *Passivation, Electropolishing or Bright Annealing surface treatments available for Stainless Steel & Incoloy® elements*
- * *Type J & K Thermocouples or RTD probes for sensing process temperatures, or over-temperature protection when attached to the sheath*
- * *Special sheath materials*
- * *Special straight bulkhead or European thread fittings*

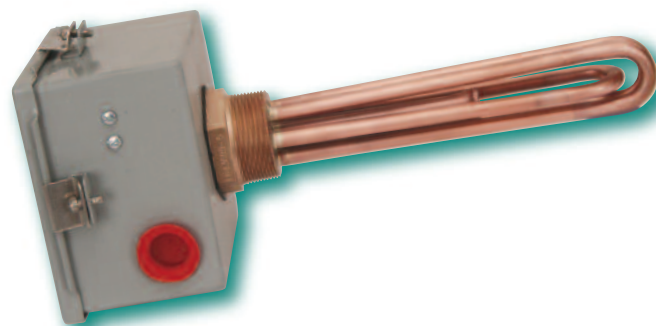
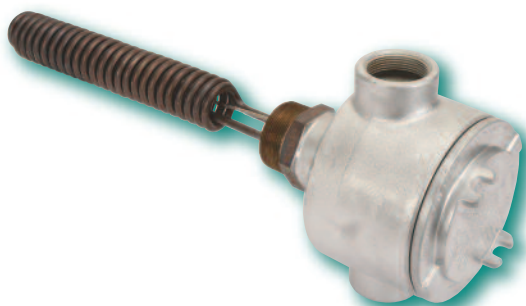

For Type TSP Screw Plug Heaters used in UL Recognized Oil Immersion Heating Applications

- The heated oil temperature cannot exceed 257°F (125°C)
- Steel sheath elements are limited to 60 watts/in²
- Steel or Stainless Steel mounting plugs (no Brass)
- Heaters with tapered threads (NPT, BSPT, or Metric) are UL rated for 60 psig maximum

Contact Tempco for other application specific UL file information.



Tempco Screw Plug Immersion Heaters are UL recognized and CSA certified in many design variations. The UL File Numbers are E90771 (CCN ÜBJY2/8) for heaters not containing a thermostat and E234452 (CCN KSXF2) for heaters used in water based solutions that include a thermostat. Tempco's equivalent CSA file number is 043099. Screw Plug heating elements and assemblies with thermostats have additionally been evaluated to UL574 (File Number MP4154) under CCN MDST2/8 for oil heating applications.

If you require UL, CSA, or other NRTL agency approvals, please specify when ordering.

View Product Inventory @ www.tempco.com

Checklist — Selecting the Proper Screw Plug Heater

☑ Determine a Safe and Efficient Element Watt Density

Element Watt Density is the wattage dissipated per square inch of the element sheath surface and is calculated with the following formula.

$$\text{Watt Density} = \frac{\text{element wattage}}{\pi \times \text{element dia.} \times \text{element heated length}}$$

For a particular application, element watt density will govern element sheath temperature.

Factors to consider when choosing a suitable watt density are:

1. Many materials are heat sensitive and can decompose or be damaged if the element is running too hot.
2. Air and other gases that are poor conductors of heat require watt densities matched to the velocity of the gas flow to prevent element overheating.
3. When heating hard water and cleaning solutions mineral deposits can build up on the element sheath, acting as a heat insulator and raising the internal element temperature. If these deposits cannot be periodically removed, use a lower watt density element to increase heater life expectancy.

☑ Select the Element Sheath Material

Sheath Material Selection

CORROSION. In addition to selecting a sheath material that is compatible with the heated medium, other factors that affect corrosion need to be considered.

1. The temperature of the corrodent. As temperature increases the degree of corrosion increases. Also remember that usually the element temperature is higher than the material it is heating.
2. The degree of aeration to which a corrodent is exposed. Stagnant conditions can deprive the stainless steels of oxygen, which is required to maintain their corrosion resistant surface.
3. Velocity of the corrodent. Increased velocity can increase the corrosion rate.



Note: See pages 16-12 through 16-20 for the recommended sheath materials for many immersion heating applications. If you are purchasing the material you are heating, check with the supplier for their recommendations.

Typical Applications

Copper Sheath—Process water, water with very weak chemical solutions, potable water, hot water storage for washrooms, showers, cleaning and rinsing parts, for freeze protection of cooling towers and sprinkler systems and other aqueous solutions not corrosive to copper sheath. Sheath temperatures to 350°F (177°C).

Incoloy® Sheath—Weak chemical solutions, oils, tar, caustic soda, detergent, alkaline solutions, molten salts, demineralized, deionized or pure water (sheath passivation is recommended), and other aqueous solutions not corrosive to Incoloy® sheath. Air, gas mixtures and superheated steam. Sheath temperatures to 1600°F (871°C).

Steel Sheath—Fluid heat transfer media, tar, high to low viscosity petroleum oils, asphalt, wax, paraffin, degreasing solvents, alcohol, molten salt, and other solutions not corrosive to steel sheath. Sheath temperatures to 750°F (399°C).

Surface Treatments for Stainless Steel and Incoloy® Elements and other Wetted Parts to Improve Corrosion Resistance

Screw Plug Immersion Heater surfaces in contact with the material being heated can be passivated or electro-polished to improve their resistance to corrosion.

Passivation removes surface contamination, usually iron, so that the optimum corrosion resistance of the stainless steel is maintained. Surface contamination would come from the small amount of steel that may be worn off a tool during the manufacturing process. Passivating is accomplished by dipping the heater in a warm solution of nitric acid.

Electro-Polishing is an electrochemical process that removes surface imperfections and contaminants, enhancing the corrosion resisting ability of the stainless steels. The resultant surface is clean, smooth and bright. Many medical and food applications require this finish.

CONTINUED

Checklist — Selecting the Proper Screw Plug Heater, *continued*

Select the Terminal Housing Type

Standard catalog screw plug immersion heaters are supplied with the **Type 1N** general purpose (NEMA 1) terminal housing with a single Dual 1/2"-3/4" conduit knockout as shown on page 11-2. Additional housings with and without a thermostat include:

Moisture Resistant (NEMA 4)

Explosion Resistant (NEMA 7)

Moisture/Explosion Resistant (NEMA 4/7)

If the housings on this page do not meet the size, construction or other criteria of your application, consult Tempco with your requirements.



Explosion resistant terminal housings are intended to provide containment of an explosion in the enclosure only. No portion of the heater assembly outside the enclosure is covered under this NEMA rating. Abnormal use of a heater which results in excessive temperature can create hazardous conditions such as a fire. Never perform any type of service nor remove the housing cover prior to disconnecting all electrical power to the heater.

Standard NEMA 1 Housing Dimensions

TYPE 1N
(for no thermostat)
for 1", 1-1/4", 2" and 2-1/2"
Screw Plug Heaters

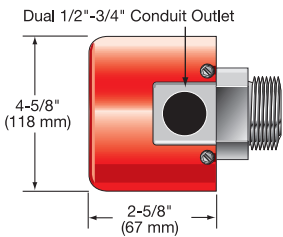

TYPE 1T
(for a single pole thermostat)
for 1", 1-1/4", 2" and 2-1/2"
Screw Plug Heaters

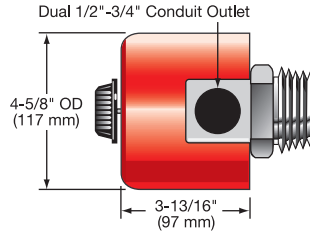

TYPE 6T
(for a double pole thermostat)
for 1", 1-1/4", 2" and 2-1/2"
Screw Plug Heaters

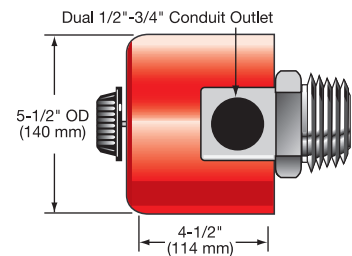

Standard NEMA 4 and/or 7 Housing Dimensions

NEMA 4 rating requires the use of the cover gasket.

TYPE 2N
(for no thermostat)
for 1", 1-1/4", 2" and 2-1/2"
Screw Plug Heaters

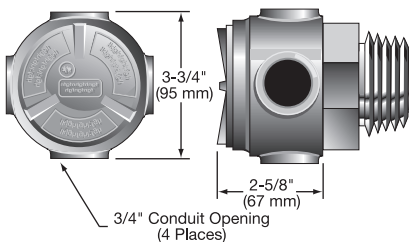

TYPE 2T
(for use with a single pole thermostat)
for 1" and 1-1/4" Screw Plug Heaters

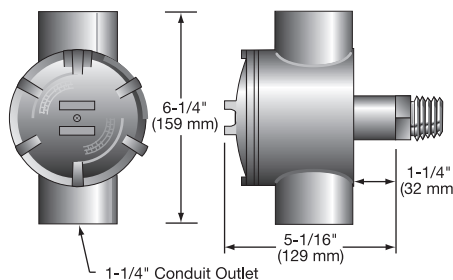

TYPE 3T
(for use with a double pole thermostat)
for 2" and 2-1/2" Screw Plug Heaters

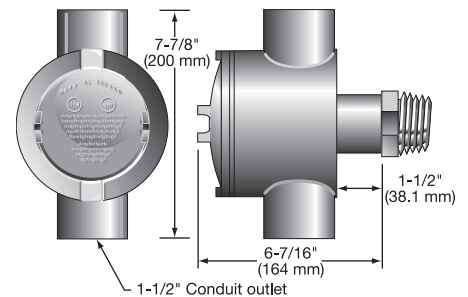

Screw Plug Immersion Heaters

Alternate NEMA 1 Housing

Type 3N

(for no thermostat)

for 1", 1-1/4", 2" and 2-1/2" Screw Plug Heaters

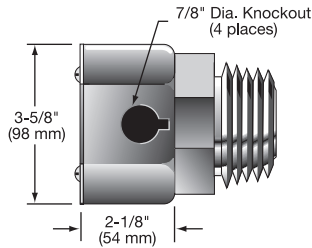

Alternate NEMA 4 Housing

TYPE 4N

(for no thermostat)

for 1", 1-1/4", 2" and 2-1/2" Screw Plug Heaters

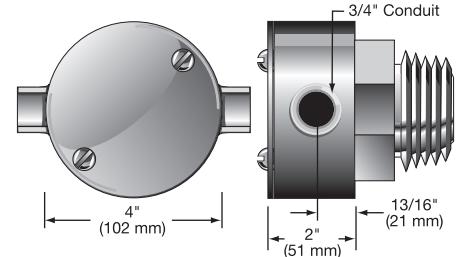

Alternate NEMA 4 Housing

TYPE 4T

(for a single pole thermostat)

for 1" and 1-1/4" Screw Plug Heaters

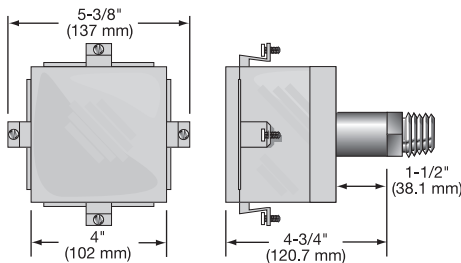

Alternate NEMA 4 Housing

TYPE 5T

(for a single or double pole thermostat)

for 2" and 2-1/2" Screw Plug Heaters

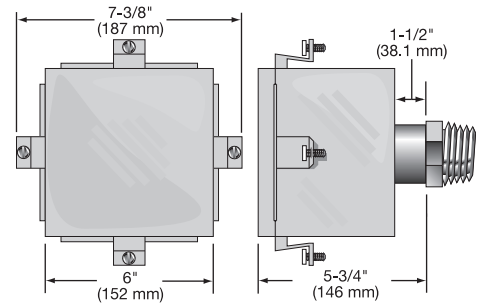

Wiring Diagrams — Screw Plug Heaters with Two Elements

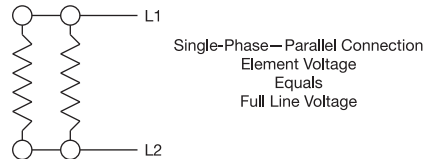
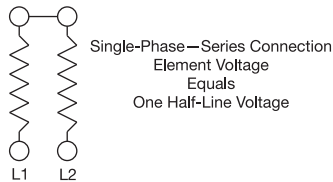
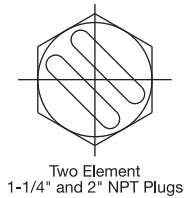

Note: Dual-Voltage heaters are factory wired for the higher voltage (series connection) unless otherwise specified. Easily rewired for lower voltage operation (parallel connection).

Wiring Diagrams — Screw Plug Heaters with Three Elements

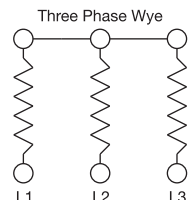
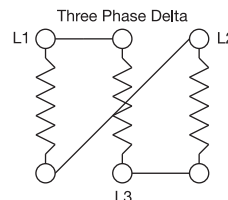
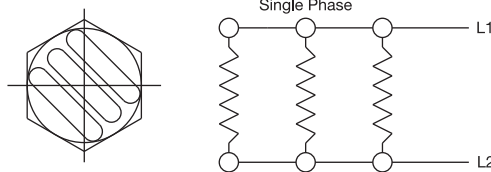
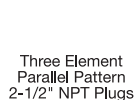
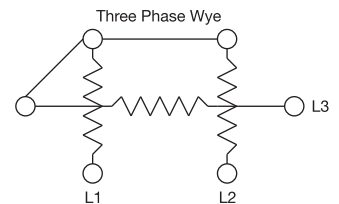
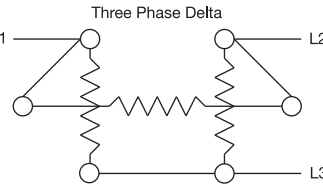
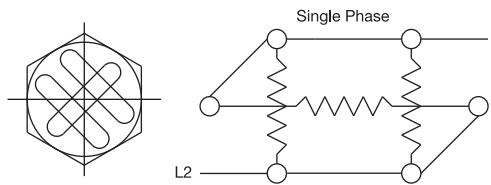
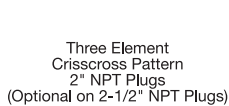

NOTE: Standard screw plug immersion heaters with three elements, factory wired for three-phase delta, can be rewired for single-phase operation with no wattage change. Wattage can be reduced to one-third of the designed wattage by switching from three-phase delta to wye connection.



Heaters wired for three-phase wye should not be changed to single-phase or three-phase delta connection, since this will increase wattage and watt density on the elements by three times the original designed wattage, causing premature heater failure.

Thermostat Styles and Selection

Construction Characteristics

This type of control operates by expansion and contraction of a liquid in response to temperature change. Liquid contained within the sensing bulb and capillary

flexes a diaphragm, causing the opening and closing of a snap-action switch. For heating applications the contacts are normally closed and open on temperature rise.

Style A Single-Pole Thermostat

Style B Double-Pole Thermostat

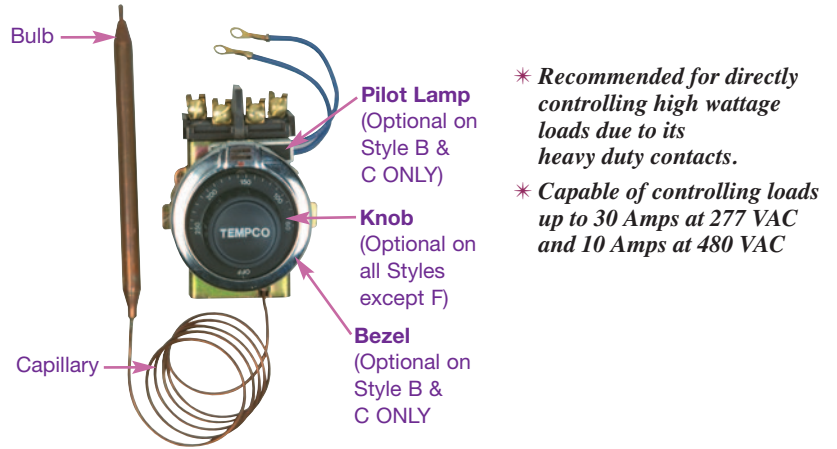
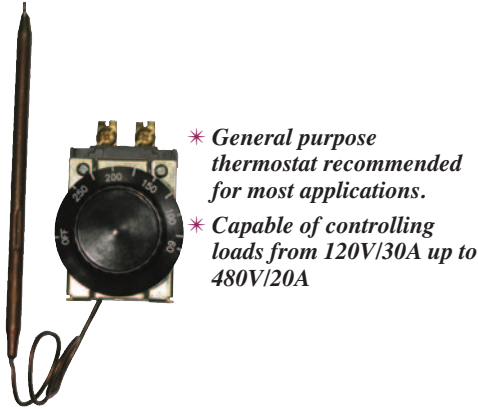

Thermostat Electrical Ratings: Normally Closed Contacts, Open on Temperature Rise – Adjustable

Stock Items Are Shown In RED

Control Type	Style	Temp Range °F	Ampacity at Line Voltage				Bulb Dia. in	Bulb Length in	Capillary Length in	Terminals	Thermostat Part Number	Optional Thermostat Parts			Instruction Sheet P/N
			120V	240V	277V	480V						Knob	Bezel	Pilot Lamp	
SPST	A	60–250	30	30	30	—	0.27	6.00	12	#10 screw	TST-101-137	TST-104-103	n/a	n/a	IDP-119-102
		60–250	30	30	30	—	0.38	4.63	48	#10 screw	TST-101-131	TST-104-103	n/a	n/a	IDP-119-102
		70–245	30	30	15	15	0.25	5.50	12	#10 screw	TST-101-130	Included	n/a	n/a	IDP-119-102
		150–550	30	30	30	—	0.31	5.00	48	#10 screw	TST-101-132	TST-104-109	n/a	n/a	IDP-119-102
		150–560	30	30	30	20	0.33	3.70	12	#10 screw	TST-101-113	TST-104-109	n/a	n/a	IDP-119-102
		200–400	30	30	30	20	0.31	5.00	36	#10 screw	TST-101-121	TST-104-112	n/a	n/a	IDP-119-102
DPST	B	30–110	30	30	30	10	0.38	6.31	36	#10 screw	TST-110-101	TST-104-110	TST-111-101	EHD-109-103	IDP-119-105
		60–250	30	30	30	10	0.38	3.88	18	#10 screw	TST-110-124	TST-104-103	TST-111-101	EHD-109-103	IDP-119-105
		60–250	30	30	30	10	0.38	3.88	24	#10 screw	TST-110-125	TST-104-103	TST-111-101	EHD-109-103	IDP-119-105
		60–250	30	30	30	10	0.38	3.88	36	#10 screw	TST-110-126	TST-104-103	TST-111-101	EHD-109-103	IDP-119-105
		60–250	30	30	30	10	0.38	3.88	60	#10 screw	TST-110-102	TST-104-103	TST-111-101	EHD-109-103	IDP-119-105
		60–250	30	30	30	10	0.38	4.5	156	#10 screw	TST-110-118	TST-104-103	TST-111-101	EHD-109-103	IDP-119-105
		100–550	30	30	30	10	0.38	3.13	24	#10 screw	TST-110-117	TST-104-104	TST-111-101	EHD-109-103	IDP-119-105
		100–550	30	30	30	10	0.38	3.88	48	#10 screw	TST-110-103	TST-104-104	TST-111-101	EHD-109-103	IDP-119-105



- Notes:**
- Knobs, Bezels and Pilot Lamps are optional and must be ordered separately from the thermostat.
 - Knob TST-104-119 graduated in °C (15-120) is available as an alternate for the standard TST-104-103 knob graduated in °F (60-250).
 - For Thermostat Enclosures refer to page 11-9.

Thermostat Wiring Diagrams

Thermostat Style A (Single Pole—Single Throw)

Typical circuit when voltage and/or line current does not exceed thermostat ratings

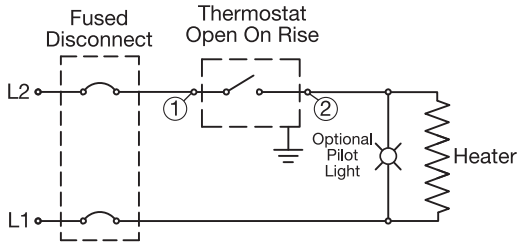

1Ø or 3Ø circuit if line voltage and/or current exceeds thermostat rating

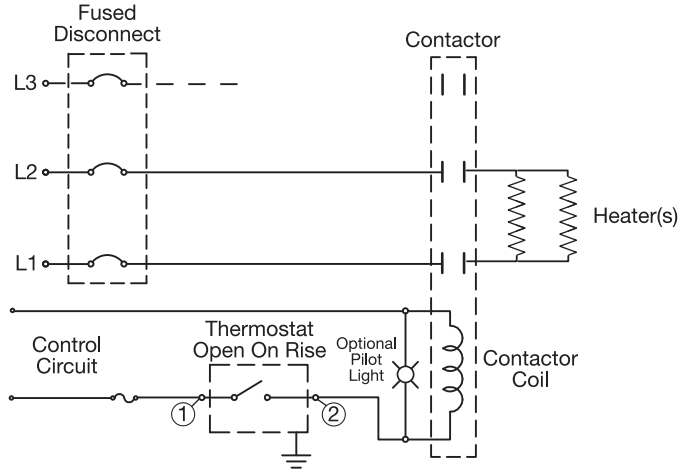

Thermostat Style B (Double Pole—Single Throw)

Typical circuit when voltage and/or line current does not exceed thermostat ratings

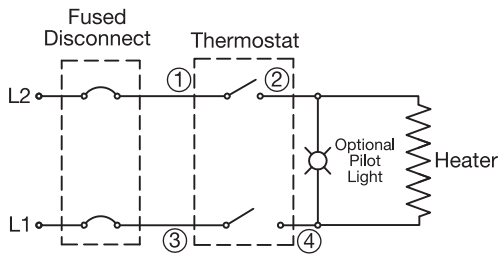

1Ø or 3Ø circuit if line voltage and/or current exceeds thermostat rating

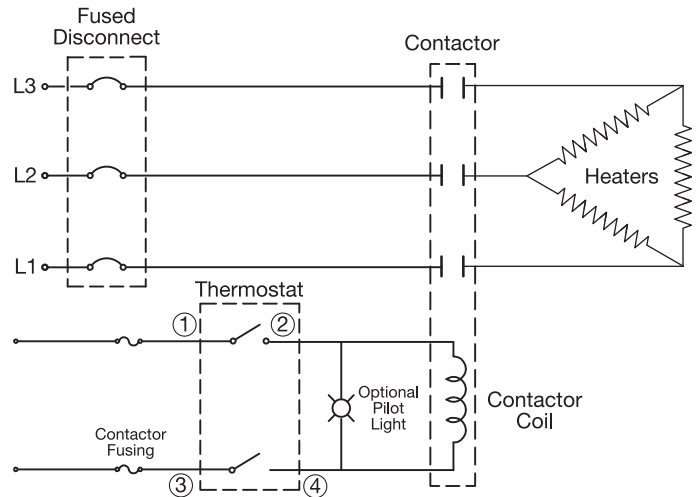

Stock Thermostat Kits

Double-Pole Thermostat Kits include the following components:

Kit Number TSTR-1008 with Style B Thermostat	
TST-110-103	Thermostat with 100 to 550°F Range
TST-104-104	Knob
EHD-109-103	Pilot lamp
TST-111-101	Bezel

Kit Number TSTR-1009 with Style B Thermostat	
TST-110-102	Thermostat with 60 to 250°F Range
TST-104-103	Knob
EHD-109-103	Pilot lamp
TST-111-101	Bezel



Note: Double-Pole Thermostat Kits can also be installed separately from the heater in housing HSGR-1004 shown on page 11-9.

Bulb & Capillary Thermostats

Thermostat Styles and Selection



Style C Double-Pole Thermostat

- * Secondary high limit circuit with manual reset
- * High limit tracks 25°F above setpoint temperature
- * High limit latches open until manual reset is pushed in the event that temperature goes up to 25°F above setpoint
- * Capable of controlling loads up to 30 Amps at 277 VAC



Style D Single-Pole Thermostat

- * General purpose thermostat recommended for most applications
- * Capable of controlling loads up to 25 Amps at 240 VAC

Thermostat Electrical Ratings: Normally Closed Contacts, Open on Temperature Rise – Adjustable

Stock Items Are Shown In RED

Control Type	Style	Temp Range °F	Ampacity at Line Voltage				Bulb Dia. in	Bulb Length in	Capillary Length in	Terminals	Thermostat Part Number	Optional Thermostat Parts			Instruction Sheet P/N
			120V	240V	277V	480V						Knob	Bezel	Pilot Lamp	
DPST	C	60–250	30	30	30	—	0.38	4.50	18	#10 screw	TST-110-127	TST-104-103	TST-111-102	EHD-109-103	IDP-119-106
		60–250	30	30	30	—	0.38	4.50	24	#10 screw	TST-110-128	TST-104-103	TST-111-102	EHD-109-103	IDP-119-106
		60–250	30	30	30	—	0.38	4.50	36	#10 screw	TST-110-129	TST-104-103	TST-111-102	EHD-109-103	IDP-119-106
		60–250	30	30	30	—	0.38	4.50	72	#10 screw	TST-110-113	TST-104-103	TST-111-102	EHD-109-103	IDP-119-106
SPST	D	20–120	25	25	—	—	0.26	4.15	24	6" leads	TST-101-109	TST-104-105	n/a	n/a	IDP-119-101
		40–107	25	25	—	—	0.27	5.88	6	6" leads	TST-101-119	TST-104-102	n/a	n/a	IDP-119-101
		47-107	25	25	—	—	0.32	2.85	8	6" leads	TST-101-106	TST-104-102	n/a	n/a	IDP-119-101
		55–115	25	25	—	—	0.26	3.70	42	6" leads	TST-101-118	TST-104-102	n/a	n/a	IDP-119-101
		60-180	22	22	18	—	0.28	4.20	6	6" leads	TST-101-105	screw adj.	n/a	n/a	IDP-119-101
		60-250	25	25	—	—	0.28	3.00	12	6" leads	TST-101-101	TST-104-101	n/a	n/a	IDP-119-101
SPDT	D	60-250	25	25	—	—	0.26	3.35	70	¼" quick conn.	TST-101-111	TST-104-101	n/a	n/a	IDP-119-101
SPDT	D	60-250	25	25	22	—	0.27	4.10	12	#10 screw	TST-101-116	TST-104-114	n/a	n/a	IDP-119-103

NOTES:

- Knobs, Bezels and Pilot Lamps are optional and must be ordered separately from the thermostat.
- Knob **TST-104-119** graduated in °C (15-120) is available as an alternate for the standard TST-104-103 knob graduated in °F (60-250).
- Knob **TST-104-105** is a plain pointer knob, not calibrated for the range.
- Knob **TST-104-102** is printed with 4 through 10, not calibrated for the range.
- For Thermostat Enclosures refer to page 11-9.

Thermostat Style C (Double Pole—Single Throw) with Reset

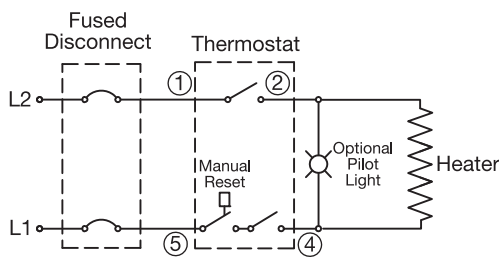

Typical circuit when voltage and/or line current does not exceed thermostat ratings

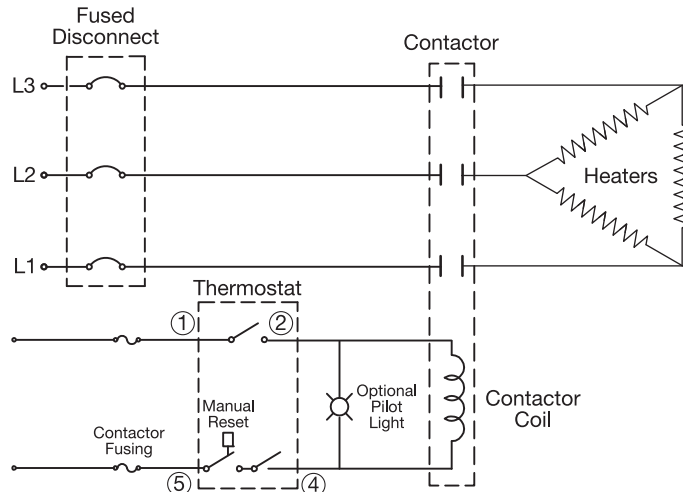

1Ø or 3Ø circuit if line voltage and/or current exceeds thermostat rating

Thermostat Wiring Diagrams

Thermostat Style D (Single Pole—Single Throw)

Typical circuit when voltage and/or line current does not exceed thermostat ratings

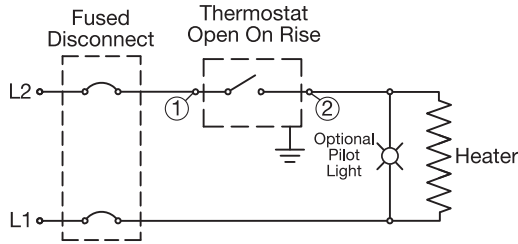

1Ø or 3Ø circuit if line voltage and/or current exceeds thermostat rating

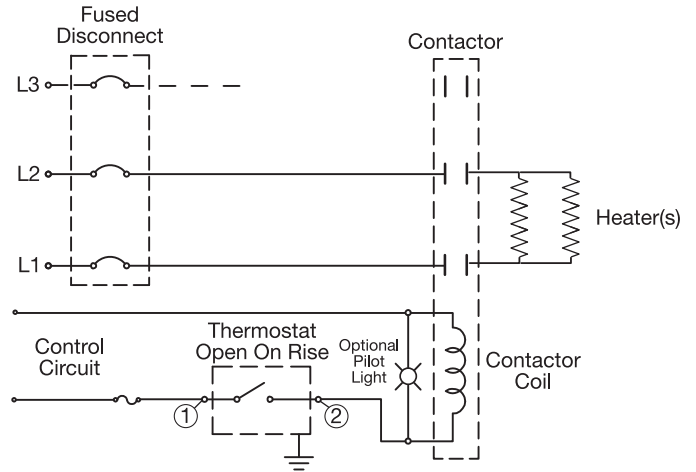

Thermostat Style D (Single Pole—Double Throw)

Typical circuit when voltage and/or line current does not exceed thermostat ratings

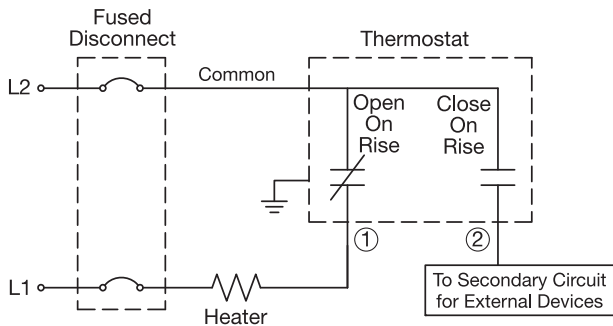

1Ø or 3Ø circuit if line voltage and/or current exceeds thermostat rating

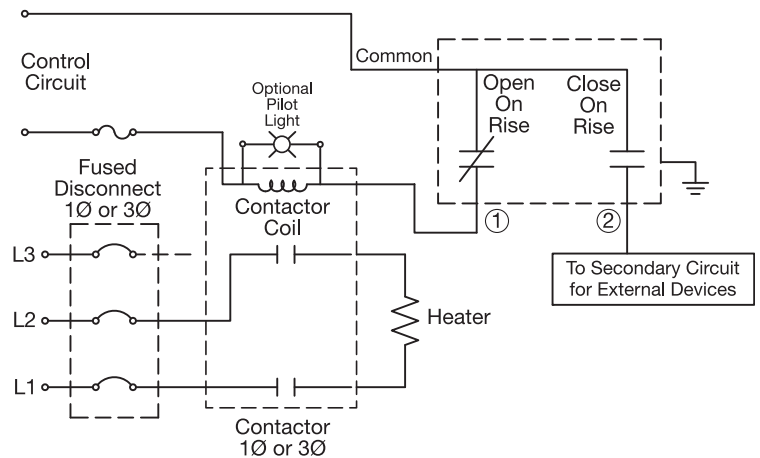

Stock Thermostat Enclosures

Thermostat Installation Warnings & Recommendations

1. Do not use the thermostat as a power switch. Use some other means of disconnecting power to the heater for servicing.
2. A thermostat is not a fail-safe device. Use an approved high temperature limit control and/or pressure limit control for safe operation.
3. Avoid kinking or bending the capillary tube too sharply as this will alter the calibration and/or render the thermostat inoperable.
4. Excess capillary tube should be coiled neatly in junction box.
5. The capillary tube must never touch the thermostat contacts as this will create an electrical short capable of harming personnel and/or equipment.



NEMA 1 Enclosure

For Single-Pole Thermostats
Size: 4-1/4"H × 3"W × 2"D
with 3/4" trade size knockout
Part Number: HSGR-1003



NEMA 1 Enclosure

For Double-Pole Thermostats
Size: 5-3/4"H × 3"W × 2"D with 1/2"
trade size knockout
Used with Thermostat kits TSTR-1008
and TSTR-1009 shown on page 11-7.
Part Number: HSGR-1004

Style F Temperature High Limit Switch with Manual Reset

Thermostat Electrical Ratings: High Limit – Manual Reset, Normally Closed Contacts, Open on Temperature Rise at Fixed Temperature

Stock Items Are Shown In **RED**

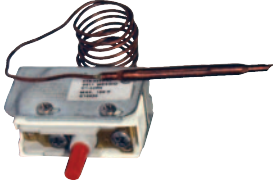

Control Type	Style	Temp Range °F	Ampacity at Line Voltage				Bulb Dia. in	Bulb Length in	Capillary Length in	Terminal	Thermostat Part Number	Instruction Sheet P/N
			120V	240V	277V	480V						
SPST	F1	118 ±3	30	30	20	20	0.32	3.00	12	#10 screw	TST-103-102	IDP-119-104
	F1	118 ±4	30	30	20	20	0.27	3.35	6	#10 screw	TST-103-109	IDP-119-104
	F1	125 ±2	30	30	20	20	0.25	3.35	36	#10 screw	TST-103-108	IDP-119-104
	F1	165 ±15	30	30	20	20	0.21	2.63	30	#10 screw	TST-103-107	IDP-119-104
	F1	200 ±5	30	30	20	20	0.31	4.00	12	#10 screw	TST-103-104	IDP-119-104
	F1	350 ±8	30	30	20	20	0.25	3.50	36	#10 screw	TST-103-103	IDP-119-104
	F2	420 ±15	30	30	30	30	0.25	4.85	30	#10 screw	TST-103-110	IDP-119-104
	F1	572 ±15	30	30	30	20	0.21	2.63	30	#10 screw	TST-103-106	IDP-119-104

NOTES: F2 style has a side vertical mounting bracket instead of #8 tapped holes for mounting. Refer to IDP-119-104 for mounting details.

Hi-Limit Thermostat Style F (Single Pole—Single Throw)

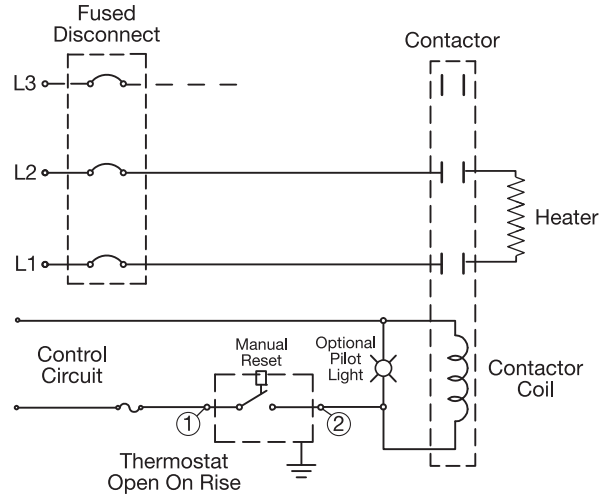
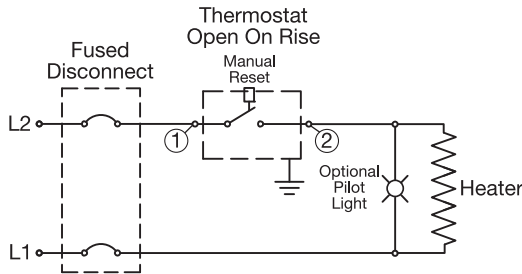

- * General purpose high limit switch with manual reset
- * Once fixed trip point is reached, the high limit switch will remain open until the manual reset button is pushed



Thermowells (Stainless Steel or Plain Steel)

Thermowells provide protection for bulb and capillary sensors. They are supplied with a 1/2" NPT male thread for mounting and a 3/8" NPT internal thread that can be used with the stuffing box assembly to secure the capillary to the well. ID: 0.50", OD: 0.56" See pages 14-76 through 14-83 for other thermowell styles.

Stock Items Are Shown In **RED**

Immersed Length		Part Number	
in	mm	Steel	Stainless Steel
12	305	MPT-120-101	MPT-121-101
18	457	MPT-120-102	MPT-121-102
24	610	MPT-120-103	MPT-121-103
36	914	MPT-120-104	MPT-121-104

Stuffing Box Assembly

The Stuffing Box Assembly is used to seal the thermostat capillary when the sensing bulb (3/8" max. OD) is immersed directly in a liquid rather than in a thermowell. The Stuffing Box consists of six slotted washers used to compress a graphite packing into a 3/8" NPT male pipe thread fitting.

Assembly Instructions

Feed sensing bulb through hole in upper and lower fitting. Insert washers and packing into top cavity of lower fitting. Upper fitting then screws into lower fitting, creating the seal.

Part Number: TST-109-101



Standard (Non-Stock) and Stock Screw Plug Immersion Heaters

Stock Items Are Shown In **RED**

8 watts/in² (1.3 watts/cm²) — Typical Applications: Fuel Oils (Bunker C and Number 6)

- * Steel Screw Plug * Steel Sheath Heating Elements * NEMA 1 Terminal Housing

NOTE: 3-Phase only. Cannot be rewired for single phase.

Nominal Pipe Size	Immersed Length		KW	Part Number		Approximate Net Weight	
	in	mm		240V-3Ph	480V-3Ph	lbs	kgs
2-1/2" NPT 3 elements	17¼	438	1	TSP01600	TSP01601	8	4
	24¾	629	1.5	TSP01602	TSP01603	9	4
	32¼	819	2	TSP01604	TSP01605	11	5
	39¾	1010	2.5	TSP01606	TSP01607	12	5
	47¼	1200	3	TSP01608	TSP01609	13	6
	63¾	1619	4	TSP01610	TSP01611	16	7
	76¼	1937	5	TSP01612	TSP01613	18	8

15 watts/in² (2.3 watts/cm²) — Typical Applications: Medium Weight Oils • Heat Transfer Oils

- * Steel Screw Plug * Steel Sheath Heating Elements * NEMA 1 Terminal Housing

NOTE: Part Numbers followed by a ① are 3-Phase only. Other 3-Phase heaters are convertible to 1-Phase.

Nominal Pipe Size	Immersed Length		KW	Part Number		Approximate Net Weight	
	in	mm		240V-3Ph	480V-3Ph	lbs	kgs
2" NPT 3 elements	13¼	337	1.5	TSP01614	TSP01615①	6	3
	17½	445	2	TSP01616	TSP01617①	7	3
	20½	521	2.5	TSP01618	TSP01619①	7	3
	25	635	3	TSP01620	TSP01621	8	4
	32½	826	4	TSP01622	TSP01623	9	4
	40	1016	5	TSP01624	TSP01625	10	5
	47½	1207	6	TSP01626	TSP01627	11	5
	58½	1486	7.5	TSP01628	TSP01629	12	5
	69¾	1772	9	TSP01630	TSP01631	14	6

Screw Plug Heater Dimensions

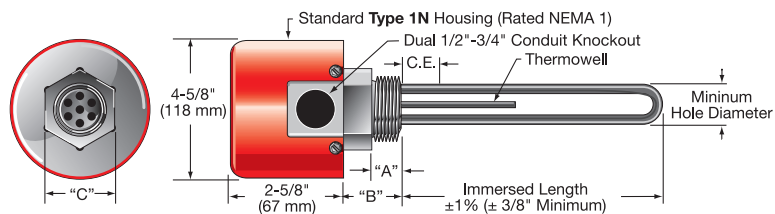

Screw Plug NPT	Minimum Hole Diameter		"A"		"B"		"C"		Thermowell Bulb Size		Standard Cold Ends (CE)		Element Diameter	
	in	mm	in	mm	in	mm	in	mm	in	mm	in	mm	in	mm
1"	1-1/8	29	7/8	22	1-1/4	32	1-3/8	35	1/4	6.4	1	25	.315	8
1-1/4"	1-3/8	35	15/16	24	1-5/16	33	1-3/4	44	1/4	6.4	1	25	.315	9
2"	2-1/4	57	1-1/16	27	1-9/16	40	2-1/2	64	3/8	9.5	2	50	.430	11
2-1/2"	2-1/2	64	1-5/16	33	2-1/16	52	3	76	3/8	9.5	2	50	.475	12

Ordering Information

See Page 11-16 for complete Ordering Information.

Standard (Non-Stock) and Stock Screw Plug Immersion Heaters

Stock Items Are Shown In **RED**

23 watts/in² (3.6 watts/cm²) — Typical Applications: **Lightweight Oils • Degreasing Solutions • Heat Transfer Oils**

* **Steel Screw Plug** * **Steel Sheath Heating Elements** * **NEMA 1 Terminal Housing**

NOTE: Dual-Voltage heaters are 1-Phase and are wired for the higher voltage unless otherwise specified.
Part Numbers followed by a ① are 3-Phase only. Other 3-Phase heaters are convertible to 1-Phase.

Nominal Pipe Size	Immersed Length		KW	Part Number						Approximate Net Weight	
	in	mm		120V-1Ph	120/240V	240V-1Ph	240V-3Ph	240/480V	480V-3Ph	lbs	kgs
1" NPT 1 element	6½	165	0.25	TSP01632	—	TSP01633	—	—	—	2	1
	7½	200	0.3	TSP01634	—	TSP01635	—	—	—	2	1
	9¼	235	0.35	TSP01636	—	TSP01637	—	—	—	2	1
	9¾	238	0.5	TSP01638	—	TSP01639	—	—	—	2	1
	13½	343	0.75	TSP01640	—	TSP01641	—	—	—	3	1
	16¾	425	1	TSP01642	—	TSP01643	—	—	—	3	1
	23¾	603	1.5	TSP01644	—	TSP01645	—	—	—	3	1
1¼" NPT 2 elements	6¾	162	0.5	—	TSP01646	—	—	—	—	3	1
	8¾	225	0.7	—	TSP01647	—	—	—	—	3	1
	10⅝	256	0.75	—	TSP01648	—	—	—	—	4	2
	12¾	324	1	—	TSP01649	—	—	—	—	4	2
	19¾	492	1.5	—	TSP01650	—	—	—	—	4	2
	25¾	645	2	—	TSP01651	—	—	—	—	5	2
	36¾	937	3	—	TSP01652	—	—	—	—	5	2
2" NPT 2 elements	9½	241	1	—	TSP01653	—	—	TSP01654	—	5	2
	13½	343	1.5	—	TSP01655	—	—	TSP01656	—	5	2
	17½	445	2	—	TSP01657	—	—	TSP01658	—	6	3
	20½	521	2.5	—	TSP01659	—	—	TSP01660	—	6	3
	25	635	3	—	TSP01661	—	—	TSP01662	—	6	3
	32½	826	4	—	TSP01663	—	—	TSP01664	—	7	3
	40	1016	5	—	TSP01665	—	—	TSP01666	—	8	4
	47½	1207	6	—	—	—	—	TSP01667	—	8	4
2" NPT 3 elements	9½	241	1.5	TSP01668	—	—	TSP01669	—	TSP01670①	5	2
	17½	445	3	TSP01671	—	—	TSP01672	—	TSP01673①	6	3
	22	559	3.75	TSP01674	—	—	TSP01675	—	TSP01676	7	3
	25	635	4.5	TSP01677	—	—	TSP01678	—	TSP01679	7	3
	32½	826	6	—	—	—	TSP01680	—	TSP01681	8	4
	40	1016	7.5	—	—	—	TSP01682	—	TSP01683	9	4
	47½	1207	9	—	—	—	TSP01684	—	TSP01685	10	5
	64	1626	12.5	—	—	—	TSP01686	—	TSP01687	12	5
2½" NPT 3 elements	17¼	438	3	TSP01688	—	—	TSP01689	—	TSP01690①	8	4
	19⅝	484	3.75	TSP01691	—	—	TSP01692	—	TSP01693	8	4
	24¾	629	4.5	TSP01694	—	—	TSP01695	—	TSP01696	9	4
	32¼	819	6	—	—	—	TSP01697	—	TSP01698	11	5
	39¾	1010	7.5	—	—	—	TSP01699	—	TSP01700	12	5
	47¼	1200	9	—	—	—	TSP01701	—	TSP01702	13	6
	63¾	1619	12.5	—	—	—	TSP01703	—	TSP01704	16	7
	76¼	1937	15	—	—	—	TSP01705	—	TSP01706	18	8

Screw Plug Heater Dimensions

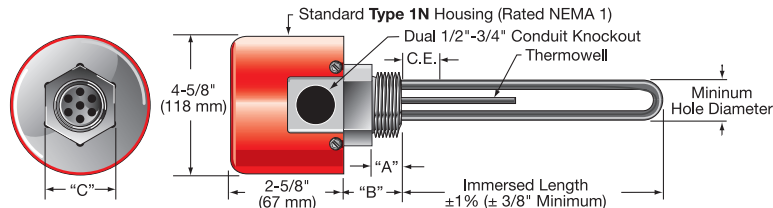

Screw Plug NPT	Minimum Hole Diameter		"A"		"B"		"C"		Thermowell Bulb Size		Standard Cold Ends (CE)		Element Diameter	
	in	mm	in	mm	in	mm	in	mm	in	mm	in	mm	in	mm
1"	1-1/8	29	7/8	22	1-1/4	32	1-3/8	35	1/4	6.4	1	25	.315	8
1-1/4"	1-3/8	35	15/16	24	1-5/16	33	1-3/4	44	1/4	6.4	1	25	.315	9
2"	2-1/4	57	1-1/16	27	1-9/16	40	2-1/2	64	3/8	9.5	2	50	.430	11
2-1/2"	2-1/2	64	1-5/16	33	2-1/16	52	3	76	3/8	9.5	2	50	.475	12



Standard (Non-Stock) and Stock Screw Plug Immersion Heaters

Stock Items Are Shown In **RED**

16 watts/in² (2.5 watts/cm²) — Typical Applications: Medium Weight Oils • Heat Transfer Oils • Liquid Paraffin

- * 304 Stainless Steel Screw Plug * Incoloy®800 Sheath Heating Elements * NEMA 1 Terminal Housing

NOTE: 3-Phase only. Cannot be rewired for single phase.

Nominal Pipe Size	Immersed Length		KW	Part Number		Approximate Net Weight	
	in	mm		240V-3Ph	480V-3Ph	lbs	kgs
2" NPT 3 elements	9¾	248	1	TSP01707	TSP01708	4	2
	13¾	337	1.5	TSP01709	TSP01710	5	2
	17¾	451	2	TSP01711	TSP01712	6	3
	20¾	514	2.5	TSP01713	TSP01714	6	3
	25¾	641	3	TSP01715	TSP01716	7	3
	32¾	832	4	TSP01717	TSP01718	8	4
	40¾	1022	5	TSP01719	TSP01720	9	4
	47¾	1213	6	TSP01721	TSP01722	10	5
2-1/2" NPT 3 elements	9¾	238	1	TSP01723	TSP01724	7	3
	12¾	327	1.5	TSP01725	TSP01726	8	4
	17¾	441	2	TSP01727	TSP01728	8	4
	19¾	505	2.5	TSP01729	TSP01730	9	4
	24¾	632	3	TSP01731	TSP01732	10	5
	32¾	822	4	TSP01733	TSP01734	11	5
	39¾	1013	5	TSP01735	TSP01736	12	5
	47¾	1203	6	TSP01737	TSP01738	13	6

23 watts/in² (3.6 watts/cm²) — Typical Applications: Forced Air & Gases • Caustic Solutions • Degreasing Solutions

- * 304 Stainless Steel Screw Plug * Incoloy®800 Sheath Heating Elements * NEMA 1 Terminal Housing

NOTE: Dual-Voltage heaters are 1-Phase and are wired for the higher voltage unless otherwise specified.

Part Numbers followed by a ① are 3-Phase only. Other 3-Phase heaters are convertible to 1-Phase.

Nominal Pipe Size	Immersed Length		KW	Part Number				Approximate Net Weight	
	in	mm		120V-1Ph	120/240V	240V-3Ph	480V-3Ph	lbs	kgs
1-1/4" NPT 2 elements	13¾	340	1	—	TSP01739	—	—	3	1
	19	483	1.5	—	TSP01740	—	—	3	1
	24¾	619	2	—	TSP01741	—	—	4	2
2" NPT 3 elements	17¾	451	3	TSP01742	—	TSP01743	TSP01744①	5	2
	25¾	641	4.5	TSP01745	—	TSP01746	TSP01747	6	3
	32¾	832	6	—	—	TSP01748	TSP01749	7	3
	40¾	1022	7.5	—	—	TSP01750	TSP01751	9	4
	47¾	1213	9	—	—	TSP01752	TSP01753	10	5
	64¾	1632	12.5	—	—	TSP01754	TSP01755	12	5
2-1/2" NPT 3 elements	76¾	1950	15	—	—	TSP01756	TSP01757	13	6
	17¾	441	3	TSP01758	—	TSP01759	TSP01760 ①	8	4
	24¾	632	4.5	TSP01761	—	TSP01762	TSP01763	9	4
	32¾	822	6	—	—	TSP01764	TSP01765	11	5
	39¾	1013	7.5	—	—	TSP01766	TSP01767	12	5
	47¾	1203	9	—	—	TSP01768	TSP01769	13	6
	63¾	1622	12.5	—	—	TSP01770	TSP01771	16	7
76¾	1940	15	—	—	TSP01772	TSP01773	18	8	

Ordering Information

See Page 11-16 for complete Ordering Information.

Standard (Non-Stock) and Stock Screw Plug Immersion Heaters

Stock Items Are Shown In RED

48 watts/in² (7.5 watts/cm²) — Typical Applications: Process Water

* 304 Stainless Steel Screw Plug * Incoloy®800 Sheath Heating Elements * NEMA 1 Terminal Housing

NOTE: Dual-Voltage heaters are 1-Phase and are wired for the higher voltage unless otherwise specified. Part Numbers followed by a ① are 3-Phase only. Other 3-Phase heaters are convertible to 1-Phase.

Nominal Pipe Size	Immersed Length		KW	Part Number					Approximate Net Weight	
	in	mm		120V-1Ph	120/240V	240V-3Ph	240/480V	480V-3Ph	lbs	kgs
2" NPT 2 elements	9¾	248	2	—	TSP01774	—	TSP01775	—	4	2
	13¾	337	3	—	TSP01776	—	TSP01777	—	4	2
	17¾	451	4	—	TSP01778	—	TSP01779	—	5	2
	20¾	514	5	—	TSP01780	—	TSP01781	—	5	2
	25¾	641	6	—	—	—	TSP01783	—	6	3
	32¾	832	8	—	—	—	TSP01784	—	6	3
	40¾	1022	10	—	—	—	TSP01785	—	7	3
	2" NPT 3 elements	9¾	248	3	TSP01786	—	TSP01787	—	TSP01788①	5
13¾		337	4.5	TSP01789	—	TSP01790	—	TSP01791①	5	2
17¾		451	6	—	—	TSP01792	—	TSP01793	6	3
20¾		514	7.5	—	—	TSP01794	—	TSP01795	6	3
25¾		641	9	—	—	TSP01796	—	TSP01797	7	3
32¾		832	12	—	—	TSP01798	—	TSP01799	8	4
40¾		1022	15	—	—	TSP01800	—	TSP01801	9	4
47¾		1213	18	—	—	TSP01802	—	TSP01803	10	5
2-1/2" NPT 3 elements	9¾	238	3	TSP01804	—	TSP01805	—	TSP01806①	7	3
	12¾	327	4.5	TSP01807	—	TSP01808	—	TSP01809①	8	4
	17¾	441	6	—	—	TSP01810	—	TSP01811	8	4
	19¾	505	7.5	—	—	TSP01812	—	TSP01813	9	4
	24¾	632	9	—	—	TSP01814	—	TSP01815	10	5
	32¾	822	12	—	—	TSP01816	—	TSP01817	11	5
	39¾	1013	15	—	—	TSP01818	—	TSP01819	12	5
	47¾	1203	18	—	—	TSP01820	—	TSP01821	13	6

Screw Plug Heater Dimensions

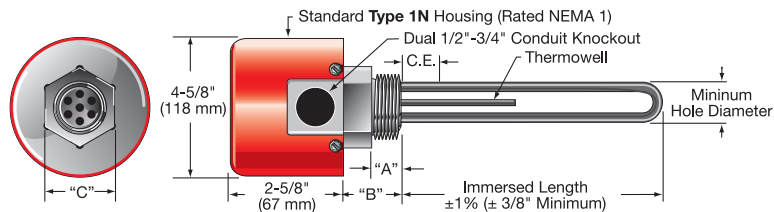

Screw Plug NPT	Minimum Hole Diameter		"A"		"B"		"C"		Thermowell Bulb Size		Standard Cold Ends (CE)		Element Diameter	
	in	mm	in	mm	in	mm	in	mm	in	mm	in	mm	in	mm
1"	1-1/8	29	7/8	22	1-1/4	32	1-3/8	35	1/4	6.4	1	25	.315	8
1-1/4"	1-3/8	35	15/16	24	1-5/16	33	1-3/4	44	1/4	6.4	1	25	.315	9
2"	2-1/4	57	1-1/16	27	1-9/16	40	2-1/2	64	3/8	9.5	2	50	.430	11
2-1/2"	2-1/2	64	1-5/16	33	2-1/16	52	3	76	3/8	9.5	2	50	.475	12



Standard (Non-Stock) and Stock Screw Plug Immersion Heaters

Stock Items Are Shown In **RED**

60 watts/in² (9.3 watts/cm²) — Typical Applications: Clean Water

* Brass Screw Plug * Copper Sheath Heating Elements * NEMA 1 Terminal Housing

NOTE: Dual-Voltage heaters are 1-Phase and are wired for the higher voltage unless otherwise specified. Part Numbers followed by a ① are 3-Phase only. Other 3-Phase heaters are convertible to 1-Phase.

Nominal Pipe Size	Immersed Length		KW	Part Number			Approximate Net Weight	
	in	mm		120V-1Ph	120/240V	240V-1Ph	lbs	kgs
1" NPT 1 element	4½	114	.5	TSP01840	—	TSP01841	2	1
	6½	165	.75	TSP01842	—	TSP01843	2	1
	6¾	168	1	TSP01844	—	TSP01845	2	1
	8	203	1.25	TSP01846	—	TSP01847	2	1
	9¼	235	1.5	TSP01848	—	TSP01849	3	1
	12½	318	2	TSP01850	—	TSP01851	3	1
	14¾	375	2.5	TSP01852	—	TSP01853	3	1
	16¾	426	3	TSP01854	—	TSP01855	3	1
1-1/4" NPT 1 element	21	533	4	—	—	TSP01856	3	1
	4¾	111	.5	TSP01857	—	TSP01858	3	1
1-1/4" NPT 2 elements	6¾	162	.75	TSP01859	—	TSP01860	3	1
	4¾	111	1	—	TSP01861	—	3	1
	6¾	162	1.5	—	TSP01862	—	3	1
	8½	216	2	—	TSP01863	—	3	1
	10¾	273	2.5	—	TSP01864	—	4	2
	15	381	3	—	TSP01865	—	4	2
	19	483	4	—	—	TSP01866	4	2
	23½	597	5	—	—	TSP01867	4	2
27½	699	6	—	—	TSP01868	5	2	

Nominal Pipe Size	Immersed Length		KW	Part Number				Approximate Net Weight		
	in	mm		120V-1Ph	120/240V	240V-3Ph	240/480V	480V-3Ph	lbs	kgs
2" NPT 2 elements	8¾	206	2	—	TSP01869	—	TSP01870	—	4	2
	11¾	283	3	—	TSP01871	—	TSP01872	—	4	2
	15¾	384	4	—	TSP01873	—	TSP01874	—	5	2
	18¾	460	5	—	TSP01875	—	TSP01876	—	5	2
	21¾	537	6	—	—	—	TSP01877	—	6	3
	26¾	676	8	—	—	—	TSP01878	—	6	3
2" NPT 3 elements	32¾	816	10	—	—	—	TSP01879	—	6	3
	8¾	206	3	TSP01880	—	TSP01881	—	TSP01882①	4	2
	11¾	283	4.5	TSP01883	—	TSP01884	—	TSP01885①	5	2
	15¾	384	6	—	—	TSP01886	—	TSP01887	5	2
	18¾	460	7.5	—	—	TSP01888	—	TSP01889	6	3
	21¾	537	9	—	—	TSP01890	—	TSP01891	6	3
2-1/2" NPT 3 elements	26¾	676	12	—	—	TSP01892	—	TSP01893	7	3
	32¾	816	15	—	—	TSP01894	—	TSP01895	8	4
	7¾	194	3	TSP01896	—	TSP01897	—	TSP01898①	4	2
	8¾	225	3.75	—	—	TSP01899	—	TSP01900①	5	2
	10¾	270	4.5	TSP01901	—	TSP01902	—	TSP01903①	5	2
	14¾	371	6	—	—	TSP01904	—	TSP01905	6	3
	17¾	448	7.5	—	—	TSP01906	—	TSP01907	6	3
	20¾	524	9	—	—	TSP01908	—	TSP01909	7	3
2-1/2" NPT 3 elements	26¾	664	12	—	—	TSP01910	—	TSP01911	8	4
	31¾	803	15	—	—	TSP01912	—	TSP01913	9	4
	37¾	943	18	—	—	TSP01914	—	TSP01915	10	5

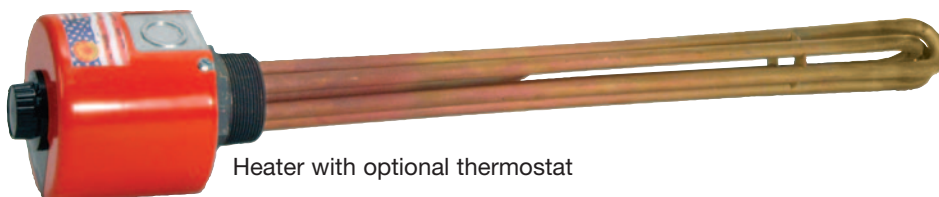

Heater with optional thermostat

Ordering Information

See Page 11-16 for complete Ordering Information.

Standard (Non-Stock) and Stock Screw Plug Immersion Heaters

Stock Items Are Shown In **RED**

60 watts/in² (9.3 watts/cm²) — Typical Applications: **Deionized Water • Demineralized Water**

* 316 Stainless Steel Screw Plug * 316 SS Sheath Heating Elements * NEMA 1 Terminal Housing

NOTE: Part Numbers followed by a ① are 3-Phase only. Other 3-Phase heaters are convertible to 1-Phase.

Nominal Pipe Size	Immersed Length		KW	Part Number			Approximate Net Weight	
	in	mm		120V-1Ph	240V-3Ph	480V-3Ph	lbs	kgs
2-1/2" NPT 3 elements	7%	194	3	TSP01822	TSP01823	TSP01824①	7	3
	10%	270	4.5	TSP01825	TSP01826	TSP01827①	7	3
	14%	372	6	—	TSP01828	TSP01829	8	4
	17%	448	7.5	—	TSP01830	TSP01831	8	4
	20%	524	9	—	TSP01832	TSP01833	9	4
	26%	664	12	—	TSP01834	TSP01835	10	5
	31%	803	15	—	TSP01836	TSP01837	11	5
	37%	943	18	—	TSP01838	TSP01839	12	5

Screw Plug Heater Dimensions

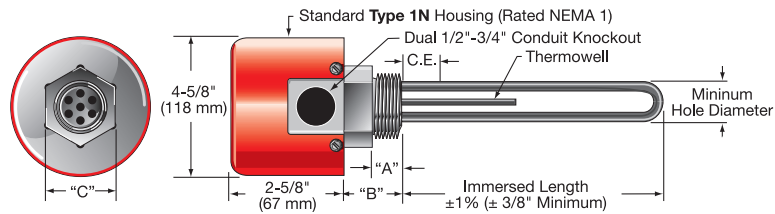

Screw Plug NPT	Minimum Hole Diameter		"A"		"B"		"C"		Thermowell Bulb Size		Standard Cold Ends (CE)		Element Diameter	
	in	mm	in	mm	in	mm	in	mm	in	mm	in	mm	in	mm
1"	1-1/8	29	7/8	22	1-1/4	32	1-3/8	35	1/4	6.4	1	25	.315	8
1-1/4"	1-3/8	35	15/16	24	1-5/16	33	1-3/4	44	1/4	6.4	1	25	.315	9
2"	2-1/4	57	1-1/16	27	1-9/16	40	2-1/2	64	3/8	9.5	2	50	.430	11
2-1/2"	2-1/2	64	1-5/16	33	2-1/16	52	3	76	3/8	9.5	2	50	.475	12

Ordering Information

Catalog Heaters

Screw Plug Immersion Heaters whose Part Numbers are in **RED** are in stock for immediate delivery. Standard Non-Stock Part Numbers are stocked as sub-assemblies for 2-3 week delivery.

Custom Engineered/Manufactured Heaters

Understanding that an electric heater can be very application specific, for sizes and ratings not listed, **TEMPCO** will design and manufacture a Screw Plug Immersion Heater to meet your requirements.

Standard lead time is 4 weeks.

Please Specify the following:

- Wattage, Voltage and Phase
- Screw Plug Size and Material
- Element Sheath Material
- Element Watt Density
- Element Immersion Length
- Electrical Enclosure Type
- Thermostat— if required
- Optional Features

⚠ WARNING: Cancer and Reproductive Harm - www.P65Warnings.ca.gov.

Stock Screw Plug Immersion Heaters With and Without Thermostats

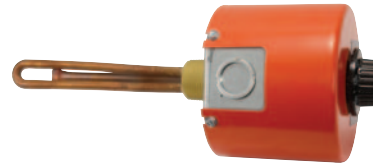

Design Features

* Brass Screw Plug

* Copper Elements

* NEMA 1 Terminal Housing

Nominal Pipe Size	Immersed Length in mm		KW	W/Sq.In.	Part Number				Approximate Net Weight lbs kgs	
					No Thermostat 120V-1Ph	With 60-250°F Thermostat 120V-1Ph	No Thermostat 240V-1Ph	With 60-250°F Thermostat 240V-1Ph		
1" NPT	6 ³ / ₈	162	0.5	46	TSP02007	TSP02078	—	—	3.1	1.4
	6 ³ / ₈	162	0.75	69	TSP02097	TSP02079	—	—	3.1	1.4
	6 ³ / ₈	162	1	92	TSP02096	TSP02080	—	—	3.1	1.4
	9 ¹ / ₄	235	1.5	90	TSP02099	TSP02081	—	—	3.5	1.6
1-1/4" NPT	6	152	1	90	TSP03340	TSP03260	TSP03341	TSP03261	3.2	1.5
	6 ¹ / ₂	165	2	94	TSP03342	TSP03262	TSP03343	TSP03263	3.4	1.5
	7 ¹ / ₄	184	1.5	60	TSP02100	TSP02082	—	—	3.6	1.6
	9	229	1.5	93	TSP03344	TSP03264	TSP03345	TSP03265	4.0	1.8
	9 ¹ / ₄	235	2	61	TSP02102	TSP02084	—	—	4.1	1.9

Nominal Pipe Size	Immersed Length in mm		KW	W/Sq.In.	Part Number				Approximate Net Weight lbs kgs	
					No Thermostat 240V-3Ph	With 60-250°F Thermostat 240V-3Ph	No Thermostat 480V-3Ph	With 60-250°F Thermostat 480V-3Ph		
2" NPT	8	203	2	40	TSP03214	TSP03213	—	—	6.5	3.0
	10	254	3	45	TSP02103	TSP02085	—	—	6.5	3.0
	11	279	4	54	TSP02104	TSP02086	—	—	6.6	3.0
	11	279	5	67	TSP02105	TSP02087	TSP02106	TSP02088	6.6	3.0
	16	406	7.5	65	TSP02107	TSP02089	TSP02008	TSP02090	7.4	3.4
2-1/2" NPT	22	559	10	61	TSP02009	TSP02091	TSP02022	TSP02092	9.5	4.3
	32 ¹ / ₄	819	12	61	—	—	TSP02108	TSP02093	12.0	5.5
	47 ³ / ₈	1203	18	44	—	—	TSP02110	TSP02095	16.5	7.5

Design Features

* Steel Screw Plug

* Steel Elements

* NEMA 1 Terminal Housing

Nominal Pipe Size	Immersed Length in mm		KW	W/Sq.In.	Part Number		Approximate Net Weight lbs kgs	
					No Thermostat 120V-1Ph	With 60-250°F Thermostat 120V-1Ph		
1" NPT	12 ¹ / ₁₆	319	0.475	21	TSP02216	TSP02204	6.6	3.0
1-1/4" NPT	12 ³ / ₄	324	1.0	23	TSP02217	TSP02205	6.7	3.0
	18 ¹ / ₂	470	1.5	23	TSP02220	TSP02208	8.2	3.7

Nominal Pipe Size	Immersed Length in mm		KW	W/Sq.In.	Part Number				Approximate Net Weight lbs kgs	
					No Thermostat 240V-3Ph	With 60-250°F Thermostat 240V-3Ph	No Thermostat 480V-3Ph	With 60-250°F Thermostat 480V-3Ph		
2" NPT	18	457	3	21	TSP02221	TSP02209	—	—	8.4	3.8
	29	737	5	21	TSP02222	TSP02210	TSP02223	TSP02211	11.8	5.4
	40 ³ / ₈	1026	5	15	TSP03518	TSP03218	—	—	14.9	6.8
	43 ¹ / ₂	1105	7.5	21	—	—	TSP02010	TSP02213	15.3	7.0
	57 ¹ / ₂	1461	10	21	—	—	TSP02226	TSP02215	18.5	8.4

Stock Screw Plug Immersion Heaters With and Without Thermostats



Design Features

- * 304 Stainless Steel Screw Plug
- * 304 Stainless Steel Elements
- * NEMA 1 Terminal Housing

Nominal Pipe Size	Immersed Length in mm		KW	W/Sq.In.	Part Number		Approximate Net Weight lbs kgs	
					No Thermostat 120V-1Ph	With 60-250°F Thermostat 120V-1Ph		
1" NPT	6 ³ / ₈	162	0.5	46	TSP02241	TSP02011	3.1	1.4
	6 ³ / ₈	162	0.75	69	TSP02295	TSP02227	3.1	1.4
	6 ³ / ₈	162	1	92	TSP02242	TSP02228	3.1	1.4
	9 ¹ / ₄	235	1.5	90	TSP02244	TSP02230	3.5	1.6
1-1/4" NPT	6 ³ / ₈	156	1	90	TSP02243	TSP02229	3.2	1.5
	6 ³ / ₈	156	1.5	94	TSP02245	TSP02024	3.2	1.5

Design Features

- * 316 Stainless Steel Screw Plug
- * 316 Stainless Steel Elements
- * NEMA 1 Terminal Housing

Nominal Pipe Size	Immersed Length in mm		KW	W/Sq.In.	Part Number				Approximate Net Weight lbs kgs	
					No Thermostat 120V-1Ph	With 60-250°F Thermostat 120V-1Ph	No Thermostat 480V-3Ph	With 60-250°F Thermostat 480V-3Ph		
1" NPT	6 ³ / ₈	162	1	46	TSP02792	TSP02791	—	—	3.1	1.4
	9 ¹ / ₄	235	1.5	90	TSP02459	TSP02793	—	—	3.5	1.6
1-1/4" NPT	9 ¹ / ₄	235	2	90	TSP02795	TSP02794	—	—	4.0	1.8
2" NPT	12	305	4.5	54	—	—	TSP03360	TSP03359	6.7	3.0
	19 ¹ / ₂	495	7.5	65	—	—	TSP03362	TSP03361	8.2	3.7
	28	711	10.5	61	—	—	TSP03364	TSP03363	11.8	5.4

Design Features

- * 304 Stainless Steel Screw Plug
- * Incoloy Elements
- * NEMA 1 Terminal Housing

Nominal Pipe Size	Immersed Length in mm		KW	W/Sq.In.	Part Number		Approximate Net Weight lbs kgs	
					No Thermostat 120V-1Ph	With 60-250°F Thermostat 120V-1Ph		
1" NPT	12 ¹ / ₁₆	319	0.475	21	TSP02264	TSP02254	4	1.8
	28 ⁷ / ₁₆	722	1.1	21	TSP02265	TSP02255	7	3.2
	34 ⁷ / ₈	886	1.325	21	TSP02266	TSP02256	8	3.6
1-1/4" NPT	11	279	1.5	37	TSP03520	TSP03519	6.5	2.9
	15 ¹ / ₂	394	3	52	TSP03522	TSP03521	7.5	3.4

Nominal Pipe Size	Immersed Length in mm		KW	W/Sq.In.	Part Number				Approximate Net Weight lbs kgs	
					No Thermostat 240V-3Ph	With 60-250°F Thermostat 240V-3Ph	No Thermostat 480V-3Ph	With 60-250°F Thermostat 480V-3Ph		
2" NPT	13	330	5	50	TSP03525	TSP03524	TSP03533	TSP03532	8	3.6
	22	559	5	28	TSP03526	TSP02258	TSP03536	TSP02012	11	5.0
	20	508	7.5	46	TSP03528	TSP03527	TSP03535	TSP03534	10	4.5
	25	635	10	48	TSP03531	TSP03530	TSP03538	TSP03537	12	5.4
	43	1092	10	27	—	—	TSP03539	TSP02260	15	6.8
2-1/2" NPT	32 ¹ / ₄	819	12	44	—	—	TSP02298	TSP02261	12	5.4
	39 ⁷ / ₈	1013	15	44	—	—	TSP02299	TSP02262	14	6.4
	47 ³ / ₈	1203	18	44	—	—	TSP02300	TSP02263	16.5	7.5

Standard (Non-Stock) Self-Contained Immersion Heaters

Design Features

This immersion heater is specifically designed for commercial dishwashers and sterilizing equipment. However, due to the unique construction characteristics of these heaters, they are readily adaptable for use in other water heating applications. The heating elements are prewired to a Definite Purpose contactor, thermostat and high limit cutout. The thermowell is located at the top of the element bundle for fast shut-off response, preventing overheating due to low water level conditions.

- * 2" NPT Brass screw plug
- * Three Incoloy® 800 tubular elements
- * Thermostat — 60°F (15°C) to 250°F (120°C) range
- * 350°F (177°C) Over-temperature cutout with manual reset
- * Internal Definite Purpose contactor with 120V holding coil
- * NEMA 4 moisture resistant housing
- * Silicone resin element seal standard



Optional Mounting Kit (Part Number KTT00281) — Clamping nut, flat washer and gasket for mounting heater in thin wall tanks with a 2-3/8" (60 mm) diameter opening.

Immersed Length		KW	Part Number					Approximate Net Weight	
in	mm		208-1Ph	208-3Ph	240V-1Ph	240V-3Ph	480V-3Ph	lbs	kgs
13 1/4	333	5	TSP01550	TSP01551	TSP01552	TSP01553	TSP01554	3	1
18 3/4	476	7.5	TSP01555	TSP01556	TSP01557	TSP01558	TSP01559	3	1
23 3/4	606	10	TSP01560	TSP01561	TSP01562	TSP01563	TSP01564	4	2
30 3/4	768	12	—	TSP01566	—	TSP01568	TSP01569	5	2
32 1/2	826	15	—	TSP01570	—	TSP01571	TSP01572	6	3
35 3/4	908	16	—	TSP01573	—	TSP01574	TSP01575	7	3
45 3/4	1162	20	—	—	—	TSP01576	TSP01577	9	4

Standard lead time is 2 to 3 weeks.

Standard (Non-Stock) General Purpose Hot Water Tank Heaters

Design Features

- * 1"-11 1/2" NPSM Brass Plug with O-Ring gasket (NPT optional)
- * Incoloy® 800 Tubular Element
- * 10-32 plated screw terminals
- * 90°C epoxy seal standard
- * Optional ceramic terminal block for high temperature applications

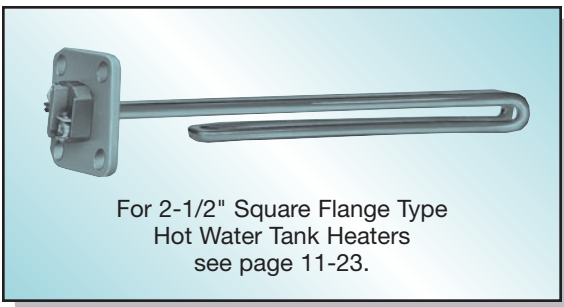
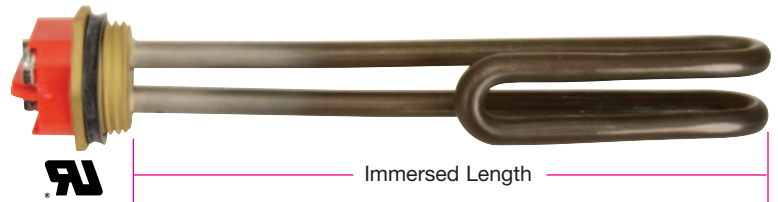
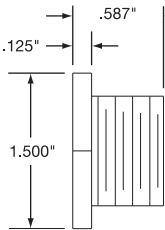

Immersed Length		KW	Voltage	Plug Material	Element Configuration	Part Number
in	mm					
8 9/16	218	3.0	208	Steel	Foldback	TSP01200
8 9/16	218	3.0	230	Steel	Foldback	TSP01198
8 9/16	218	3.0	460	Steel	Foldback	TSP01161
10 13/16	275	2.0	230	Steel	No Foldback	TSP01259
10 3/8	264	2.0	460	Steel	No Foldback	TSP01195
12 13/16	325	4.0	230	Steel	Foldback	TSP01324
7 7/8	187	1.5	240	Brass	Foldback	TSP01286
15 7/8	403	4.5	240	Brass	Foldback	TSP01148

Standard lead time is stock to 3 weeks.

Type FAH Flanged Aluminum Finned Oil Immersion Heaters

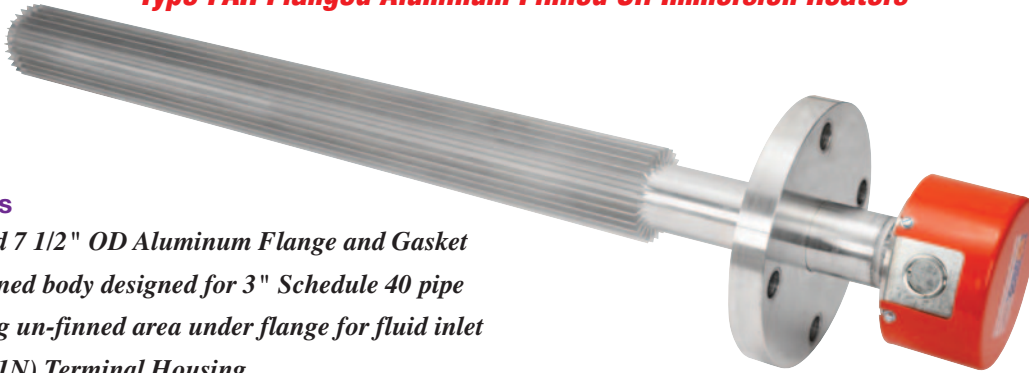

Design Features

- * 3" - 150 lb rated 7 1/2" OD Aluminum Flange and Gasket
- * 2-7/8" OD Finned body designed for 3" Schedule 40 pipe
- * 2" OD x 5" long un-finned area under flange for fluid inlet
- * NEMA 1 (type 1N) Terminal Housing
- * 3-phase single circuit winding designs (48 amps max.)
- * 1/4-20 threaded studs for secure connections to power supply
- * Flange mates to standard 3" CHF Circulation Heater pipe body

Optional Features

- * Single- or three-phase designs from 120V to 600V maximum
- * Alternate terminal housings — None, NEMA 4, NEMA 4/7 or NEMA 12
- * 3" — 300 lb & 600 lb rated Aluminum mounting flanges
- * Optional internal overtemperature type K or J thermocouple sensor in heated zone. 24" pigtail leads standard in housing. (700°F maximum controller setting)
- * Alternate size ASA style Flanges — 3-1/2" & 4" in 150 lb ratings
- * Round, rectangular/square non-pressure rated Aluminum mounting flanges.
- * 3" or 4" size cast aluminum screw plug mounting in place of flange
- * Finned area watt densities 4 -16 for oil/organic fluids
- * External power wiring options including armored cable, braided or plain lead wire



Type FAH heaters are primarily designed for use in oil heating and oil separation systems at immersion media temperatures not exceeding 250°F. Heaters must be used with suitable high-limit temperature controls to keep the external aluminum finned surface area from exceeding 500-550°F. A liquid level sensor is required to insure that the heater is always fully immersed.

Heater must not be allowed to operate if not fully immersed or there is no or low liquid flow (below 2 gpm). If used for heating static liquids in a tank, an internal high-limit thermocouple and an external temperature control set to 700°F should be used. See catalog Section 13 and 14.



Optional NEMA 4/7 Housing

FAH Immersion Heaters are designed for immersion heating of oils, heat transfer fluids, hydraulic fluids, and organic fluids non-corrosive to aluminum. The lightweight outer finned structure in contact with the heated media provides a low watt density surface in shorter immersion lengths for heating sensitive organic fluids that are susceptible to coking and carbonization.

The heaters are designed for fuel oil heating up to 250°F, and higher watt density versions are available for heat transfer fluid circulation systems up to 400°F. They are also ideal for heating glycol water solutions non-corrosive to the 6063 aluminum finned body and welded flange. They can be used in static tank heating or flowing oil applications.

The FAH series presents a smooth uniform heat transfer area to the flowing fluid, resulting in efficient heating with a minimum pressure drop. When used with a standard 3" schedule 40 pipe body it provides a 3.75 sq.in. cross-sectional flow area for the fluid. It can also be used effectively in 3-1/2" or 4" ID pipe bodies in order to provide an increased flow area for heavier, higher viscosity fluids. When used in the 3-1/2" pipe, the cross-sectional flow is 6.64 sq.in., and is 9.05 sq.in. for 4" pipe. Pipe ID's larger than this may not heat the flowing fluid properly.



Tempco Finned Aluminum Heaters have been certified as Recognized Components by Underwriters Laboratories (File Number MP4154) under CCN MDST2/8 to meet UL Standard 574 for oil heating. These heaters are also CSA certified for general immersion use under Tempco CSA File Number 043099.

If you require UL, CSA, or other NRTL agency approvals, please specify when ordering.

For Type FAH Flanged Heaters used in UL Recognized Oil Immersion Heating Applications

- The heated oil temperature cannot exceed 257°F (125°C)
- Flanged heater designs are UL rated to a maximum operating pressure of 150 psig
- Optional NPT screwplug designs are UL rated to a maximum operating pressure of 60 psig.
- The maximum finned surface area watt density is 16 watts/in²
- Maximum Wattage/Voltage: 24KW/600V

Contact Tempco for other application specific UL file information.

View Product Inventory @ www.tempco.com

Standard (Non-Stock) Flanged Aluminum Finned Immersion Heaters

Design Features

- * 3" — 150-lb ANSI Flange
- * NEMA 1 Terminal Housing
- * Three-Phase Single Circuit
- * Watt Density of 7 watts/in² on finned area

Immersed Length		KW	Part Number			Approximate Net Weight		CHF* Dimensional Drawing Number
in	mm		240V-3Ph	480V-3Ph	575V-3Ph	lbs	kgs	
20	508	3	FAH00001	FAH00002	FAH00003	21	9	—
27	686	4.5	FAH00004	FAH00005	FAH00006	23	11	3.1
35	889	6	FAH00007	FAH00008	FAH00009	26	12	3.2
42	1067	7.5	FAH00010	FAH00011	FAH00012	28	13	—
50	1270	9	FAH00013	FAH00014	FAH00015	31	14	3.3
64	1626	12	FAH00016	FAH00017	FAH00018	36	16	—
84	2134	16	FAH00019	FAH00020	FAH00021	43	20	—

* See catalog page 11-51 (Drawing Number 3) for standard flanged CHF circulation heater tank sizes available for this heater immersion length.

Design Features

- * 3" — 150-lb ANSI Flange
- * NEMA 1 Terminal Housing
- * Three-Phase Single Circuit
- * Watt Density of 12 watts/in² on finned area

Immersed Length		KW	Part Number			Approximate Net Weight		CHF* Dimensional Drawing Number
in	mm		240V-3Ph	480V-3Ph	575V-3Ph	lbs	kgs	
14	356	3	FAH00022	FAH00023	FAH00024	19	8	—
18	457	4.5	FAH00025	FAH00026	FAH00027	20	9	—
22	559	6	FAH00028	FAH00029	FAH00030	21	10	—
27	686	7.5	FAH00031	FAH00032	FAH00033	23	11	3.1
31	787	9	FAH00034	FAH00035	FAH00036	25	11	—
38	1016	12	FAH00037	FAH00038	FAH00039	27	12	3.2
50	1295	16	FAH00040	FAH00041	FAH00042	31	14	3.3
62	1575	20	—	FAH00043	FAH00044	35	16	—
74	1880	24	—	FAH00045	FAH00046	39	18	—

* See catalog page 11-51 (Drawing Number 3) for standard flanged CHF circulation heater tank sizes available for this heater immersion length.

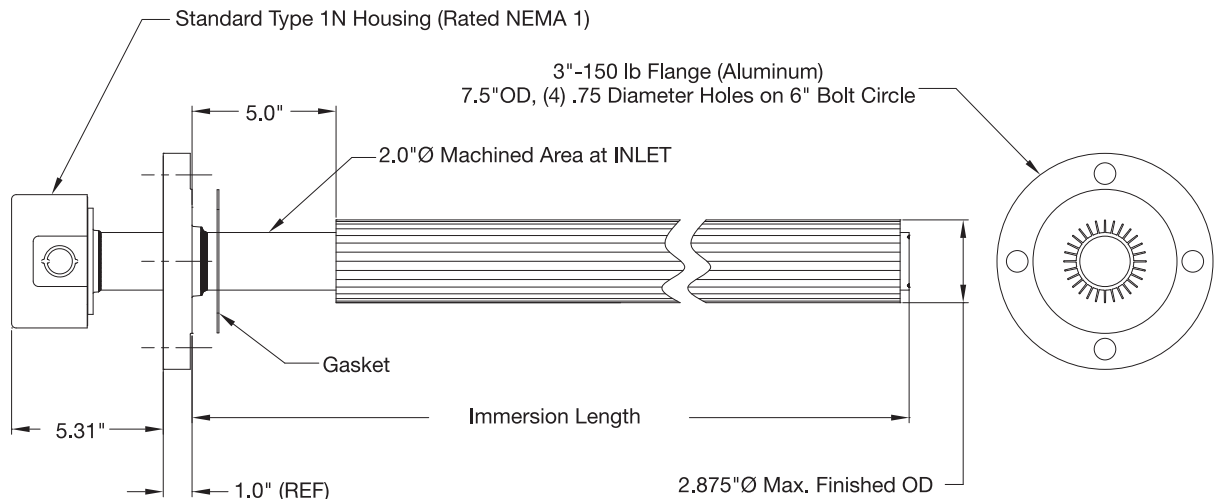

Flanged Immersion Heaters With Custom Size And Shape Flanges

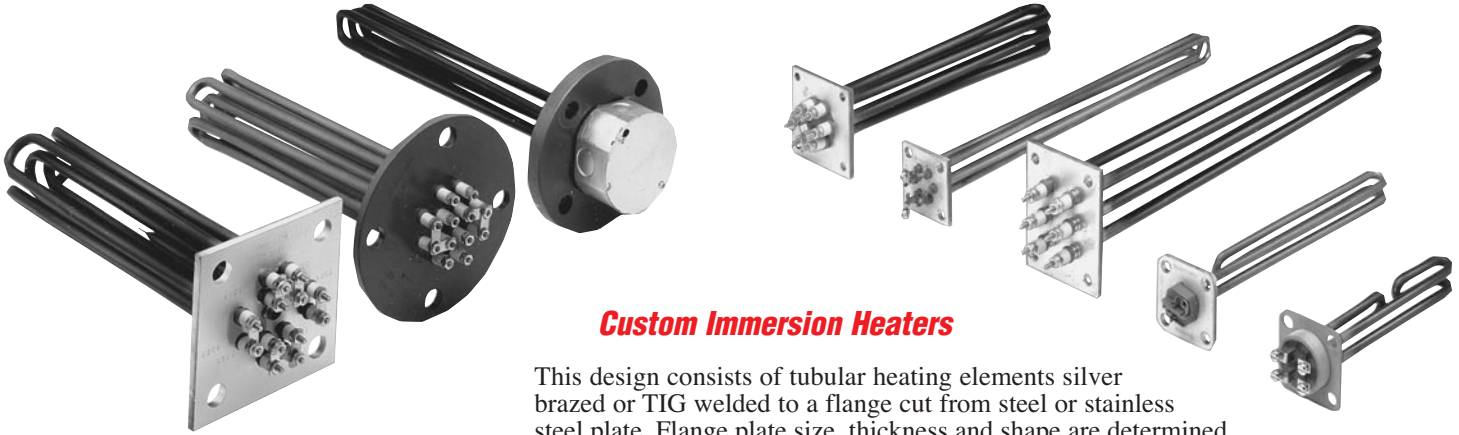

Custom Immersion Heaters

This design consists of tubular heating elements silver brazed or TIG welded to a flange cut from steel or stainless steel plate. Flange plate size, thickness and shape are determined by the application. A fiber gasket is supplied with each heater.

The various style heaters in the Stock Lists on pages 11-22 through 11-25 are direct replacements for heaters in many OEM applications.

This type construction also lends itself to be easily and economically engineered into new equipment.

Typical Applications

- ↔ Hot Air Dryers
- ↔ Dehumidifying Dryers
- ↔ Heat Exchange Systems
- ↔ Water and Water Solutions
- ↔ Steam Tables
- ↔ Air Heating

For Type TPN Flanged Heaters used in UL Recognized Oil Immersion Heating Applications

- The heated oil temperature cannot exceed 257°F (125°C)
- TPN designs are not UL pressure rated
- Steel sheath elements are limited to 60 watts/in²

Contact Tempco for other application specific UL file information.



Tempco TPN Flanged Immersion Heaters are UL component recognized and CSA certified in most design variations for (non-pressure rated) general immersion heater use. The UL File Number is E90771 (CCN UBJY2/8) and the equivalent CSA File Number is 043099. They are also UL recognized under UL standard UL574 for oil heating, File Number MP4154 (CCN MDS2/8)

If you require UL, CSA, or other NRTL agency approvals, please specify when ordering.

3-1/2" Square Steel Flange • 3 Elements

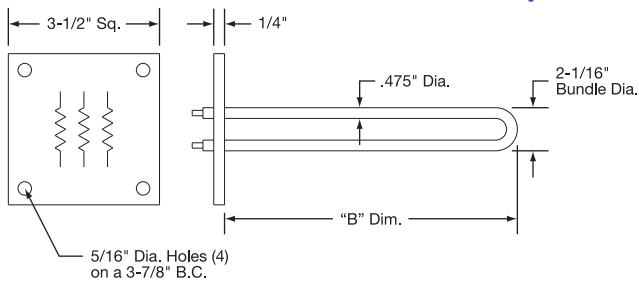

Supplied with gasket (GSK-110-102)

Standard (Non-Stock) and Stock Flanged Heaters

Stock Items Are Shown In RED

Element Sheath Material	KW	Watt Density		"B"		Part Number			Approximate Net Weight	
		W/in ²	W/cm ²	in	mm	240V-3Ph Y	480V-3Ph Y	575V-3Ph Y	lbs	kgs
Incoloy® 800	1.5	15	2.3	12 ⁷ / ₁₆	316	TPN01400	TPN01401	—	3	1.4
	2.5	24	3.7	12 ⁷ / ₁₆	316	TPN01173	TPN01174	TPN01402	3	1.4
	3	31	4.8	12 ⁷ / ₁₆	316	TPN01403	TPN01404	TPN01405	3	1.4
	3.5	24	3.7	17 ⁷ / ₈	454	TPN01175	TPN01201	TPN01406	4	1.8
	4	27	4.2	17 ⁷ / ₈	454	TPN01407	TPN01176	TPN01408	4	1.8
	5	34	5.3	17 ⁷ / ₈	454	TPN01409	TPN01410	TPN01411	4	1.8
Steel	2.5	24	3.7	12 ⁷ / ₁₆	316	TPN01351	TPN01373	—	3	1.4
	3.5	24	3.7	17 ⁷ / ₈	454	TPN01311	TPN01412	—	4	1.8

Standard lead time on non-stock items is 3 to 4 weeks.

6" Square Steel Flanged • 6 Incoloy® 800 Elements • 2 Circuits

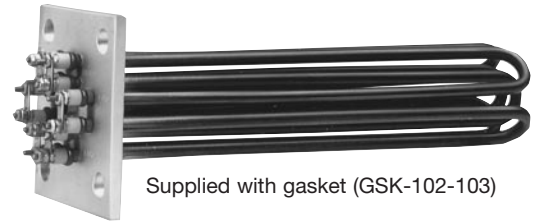
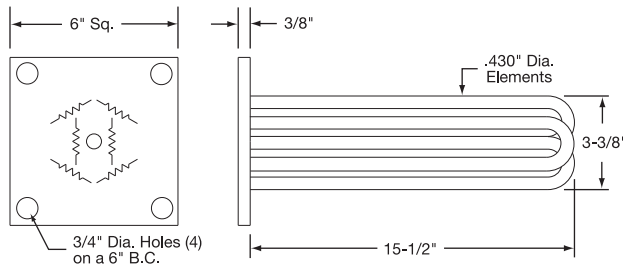

Supplied with gasket (GSK-102-103)

Standard (Non-Stock) and Stock Flanged Heaters
Stock Items Are Shown In RED

Element Sheath Material	KW	Watt Density		Part Number				Approximate Net Weight	
		W/in ²	W/cm ²	208V-3Ph	230V-3Ph	460V-3Ph	575V-3Ph	lbs	kgs
Incoloy® 800	9	44	6.8	TPN01168	TPN01169	TPN01170	TPN01424	8	3.6
	10.5	52	8.1	TPN01425	TPN01426	TPN01427	TPN01428	8	3.6
	12	60	9.3	TPN01171	TPN01429	TPN01172	TPN01430	8	3.6
	15	70	10.9	TPN01431	TPN01432	TPN01433	TPN01434	8	3.6

Standard lead time on non-stock items is 3 to 4 weeks.

6" Square Steel Flanged • 6 Incoloy® 800 Elements

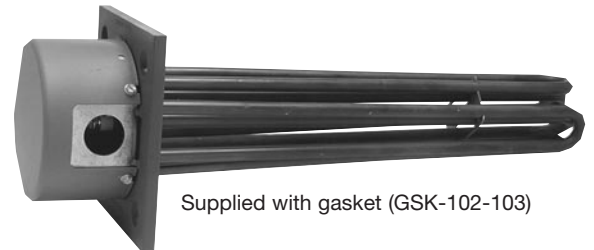
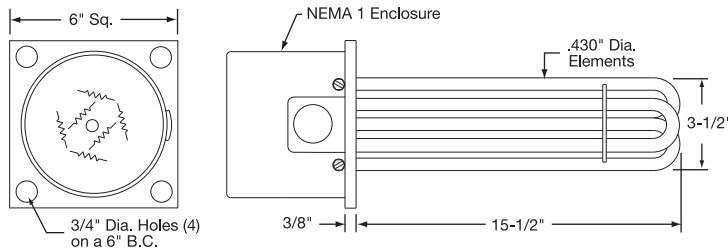

Supplied with gasket (GSK-102-103)

Standard (Non-Stock) and Stock Flanged Heaters
Stock Items Are Shown In RED

Standard lead time on non-stock items is 3 to 4 weeks.

Element Sheath Material	KW	Watt Density		Part Number			Approximate Net Weight	
		W/in ²	W/cm ²	208V-3Ph	240/480V-3Ph	575V-3Ph	lbs	kgs
Incoloy® 800	4.5	20	3.1	TPN01413	TPN01414	—	9	4.1
	9.0	40	6.2	TPN01415	TPN01416	TPN01417	9	4.1
	10.5	47	7.3	TPN01418	TPN01419	TPN01420	9	4.1
	12.0	54	8.4	TPN01421	TPN01422	TPN01423	9	4.1

Standard (Non-Stock) Hot Water Tank Heater • 2-1/2" Square Steel Flanged • 1 Incoloy® 800 Element

Immersed Length		KW	Part Number	
in	mm		120V	240V
9¼	235	1.0	—	TPN01484
11	279	1.25	TPN01485	TPN01486
7¾	187	1.5	TPN01487	TPN01488
9	279	2.0	TPN01489	TPN01490
10¾	273	2.5	—	TPN01491
12¾	313	3.0	—	TPN01167
13¾	349	3.5	—	TPN01492
15¾	400	4.0	—	TPN01493
16¾	413	4.5	—	TPN01494
19	483	5.0	—	TPN01287

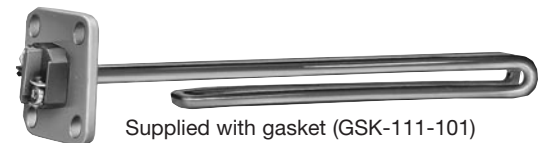
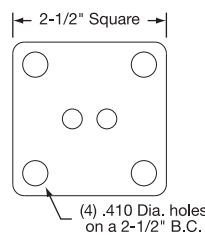

Supplied with gasket (GSK-111-101)

Design Features

- * 2-1/2" Square × 1/4" thick flange with gasket
- * 70 w/in² Incoloy® 800 tubular heating element
- * 10-32 plated screw terminals
- * Optional ceramic terminal block for high temperature applications

Standard lead time on non-stock items is 3 to 4 weeks.

7-1/2" Diameter Steel Flanged • 6 Elements

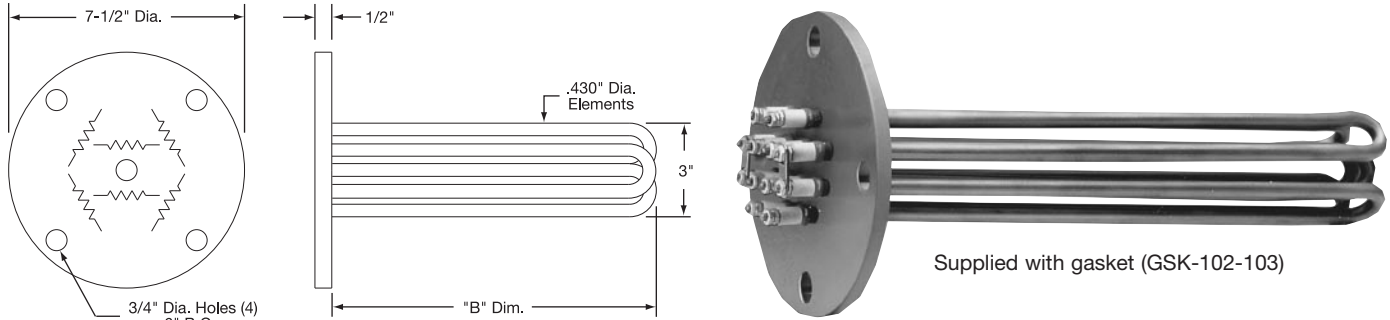

Standard (Non-Stock) and Stock Flanged Heaters Stock Items Are Shown In **RED**

Element Sheath Material	KW	Watt Density		"B"		Part Number			Approximate Net Weight	
		W/in ²	W/cm ²	in	mm	208V-3Ph	240V-3Ph Y	480V-3Ph Y	lbs	kgs
Incoloy [®] 800	7.5	50	7.8	12	305	TPN01468	TPN01165	TPN01469	12	5.5
	9	42	8.1	15 $\frac{1}{8}$	403	TPN01470	TPN01350	TPN01211	14	6.4
	10	50	7.8	15 $\frac{1}{8}$	403	TPN01471	TPN01472	TPN01473	14	6.4
	12	53	8.2	15 $\frac{1}{8}$	403	TPN01474	TPN01475	TPN01476	14	6.4
Copper	9	42	8.1	15 $\frac{1}{8}$	403	TPN01477	TPN01478	TPN01479	14	6.4
	10	50	7.8	15 $\frac{1}{8}$	403	TPN01480	TPN01481	TPN01260	14	6.4
	12	53	8.2	15 $\frac{1}{8}$	403	TPN01482	TPN01483	TPN01299	14	6.4

Standard lead time on non-stock items is 3 to 4 weeks.

7" Diameter Steel Flange • 3 Incoloy[®] 800 Elements

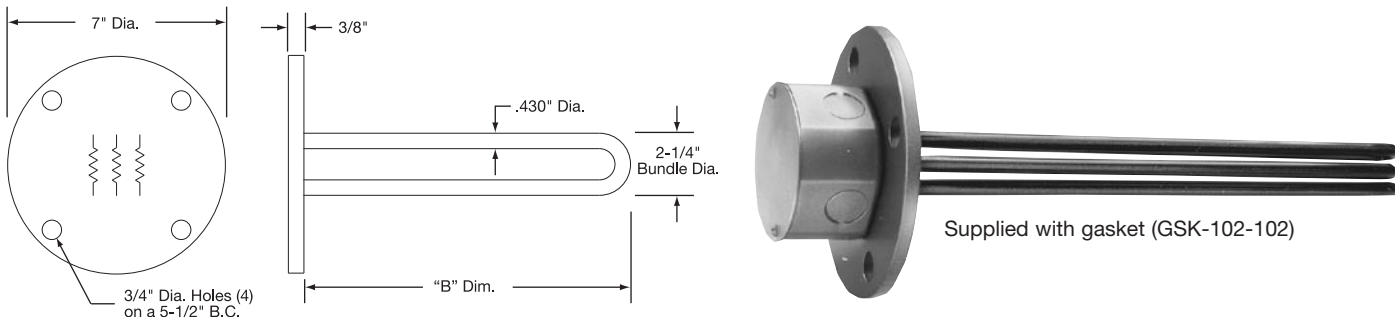

Standard (Non-Stock) and Stock Flanged Heaters Stock Items Are Shown In **RED**

Element Sheath Material	KW	Watt Density		"B"		Part Number				Approximate Net Weight	
		W/in ²	W/cm ²	in	mm	240V-1Ph	240V-3Ph	480V-1Ph	480V-3Ph	lbs	kgs
Incoloy [®] 800	3	24	3.7	17 $\frac{1}{8}$	448	TPN01460	TPN01461	TPN01462	TPN01463	6	2.7
	4.5	50	7.8	12 $\frac{1}{2}$	314	TPN01347	TPN01339	TPN01464	TPN01465	5	2.3
	9	70	10.8	17 $\frac{1}{8}$	454	TPN01348	TPN01198	TPN01349	TPN01223	6	2.7
	12	70	10.8	22 $\frac{1}{8}$	581	—	TPN01304	TPN01466	TPN01467	6	2.7

Standard lead time on non-stock items is 3 to 4 weeks.

6-1/2" Diameter Steel Flange • 6 Incoloy® 800 Elements • 1 Circuit

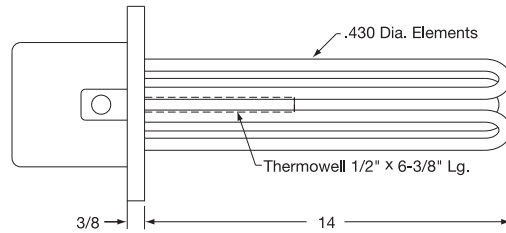
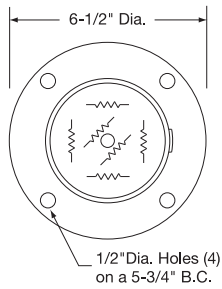

Supplied with gasket (GSK-102-103)

Standard (Non-Stock) and Stock Flanged Heaters

Stock Items Are Shown In **RED**

Element Sheath Material	KW	Watt Density		Part Number 460V-3Ph	Approximate Net Weight	
		W/in ²	W/cm ²		lbs	kgs
Incoloy® 800	9	46	7.1	TPN01706	10	4.5
	12	62	9.6	TPN01707	10	4.5

Heaters can be factory rewired for 230V-3PH.

6-1/2" Diameter Steel Flange • 6 Elements • 2 Circuits

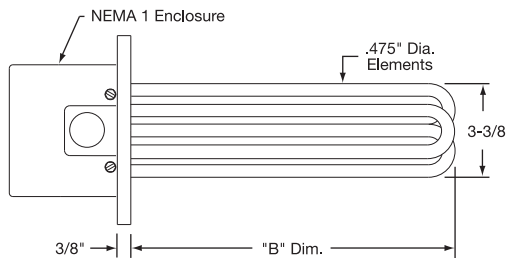
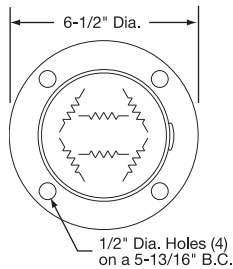

Supplied with gasket (GSK-102-103)

Standard (Non-Stock) and Stock Flanged Heaters

Stock Items Are Shown In **RED**

Element Sheath Material	KW	Watt Density		B		Part Number				Approximate Net Weight	
		W/in ²	W/cm ²	in	mm	208V-3Ph	230V-3Ph	460V-3Ph	575V-3Ph	lbs	kgs
Incoloy® 800	9	50	7.8	17	432	TPN01448	TPN01177	TPN01178	TPN01449	10	4.5
	10.5	42	8.1	17	432	TPN01450	TPN01451	TPN01452	TPN01453	10	4.5
	12	50	7.8	17	432	TPN01454	TPN01204	TPN01179	TPN01455	10	4.5
Copper	12	48	7.4	17	432	TPN01319	TPN01456	TPN01321	—	10	4.5
	15	70	10.9	28	711	TPN01457	TPN01458	TPN01459	—	12	5.4

Ordering Information

Catalog Heaters

Flanged Immersion Heaters whose Part Numbers are in **RED** are available from Stock for immediate delivery.

Standard Non-Stock Part Numbers have a 2-3 week lead time.

Custom Engineered/Manufactured Heaters

An electric heater can be very application specific; for sizes and ratings not listed, **TEMPCO** will design and manufacture a Flanged Immersion Heater to meet your requirements. **Standard lead time is 3 to 4 weeks.**

Please Specify the following:

- Wattage, Voltage and Phase
- Flange Size and Material
- Element Sheath Material
- Element Watt Density
- Element Immersion Length
- Electrical Enclosure, if required
- Optional Features

⚠ WARNING: Cancer and Reproductive Harm - www.P65Warnings.ca.gov.

Flanged Immersion Heaters

Flanged Immersion Heaters are designed for use in tanks and pressurized vessels to heat both liquids and gases. They mate to a companion flange that is either welded to a tank

wall or, for circulating type heaters, to a pipe. See pages 11-46 through 11-69 for TEMPCO circulation heaters, which consist of a flange heater and a pipebody pressure vessel assembly.

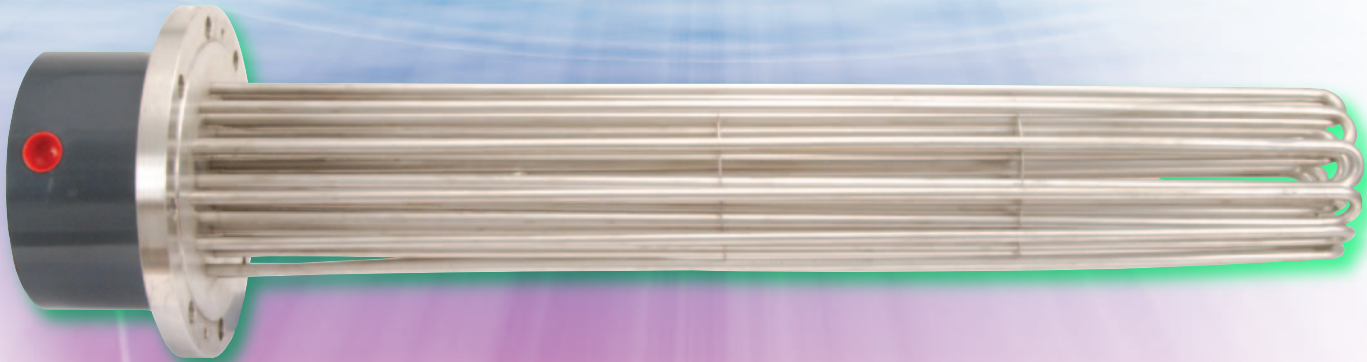

Design Features

The catalog items listed on pages 11-32 through 11-44 have the following features, making them suitable for many applications:

- * 150-lb forged steel or 316 stainless steel flanges
- * Gasket Supplied
- * Incoloy® 800, 316 stainless steel, steel or copper tubular elements
- * Element hairpin bends are spanked in specially designed dies to re-compact the MgO insulating powder
- * Silicone resin seal of elements standard
- * 1/2" OD thermowell for a 3/8" diameter sensing bulb
- * NEMA 1 electrical enclosure
- * Standard heaters have elements wired into branch circuits having a maximum current of 48 Amps

The items listed in this catalog are only a small sample of the heaters that can be supplied by TEMPCO. The next few pages will describe both standard and optional materials and features available to meet the requirements of your application.

Checklist – Selecting the Proper Flanged Heater

Determine a Safe and Efficient Element Watt Density

Element Watt Density is the wattage dissipated per square inch of the element sheath surface and is calculated with the following formula:

$$\text{Watt Density} = \frac{\text{element wattage}}{\pi \times \text{element dia.} \times \text{element heated length}}$$

For a particular application, element watt density will govern element sheath temperature. Factors to consider when choosing a suitable watt density are:

1. Many materials are heat sensitive and can decompose or be damaged if the element is running too hot.
2. Air and other gases that are poor conductors of heat require watt densities matched to the velocity of the gas flow to prevent element overheating.
3. When heating hard water and cleaning solutions mineral deposits can build up on the element sheath, acting as a heat insulator and raising the internal element temperature. If these deposits cannot be periodically removed, use a lower watt density element to increase heater life expectancy.

Determine Pressure-Temperature Rating of Flange Required

NOTE: Catalog heaters listed on pages 11-32 through 11-44 have Class 150-lb flanges. For heaters with a higher Pressure-Temperature Rating consult Tempco.

Pressure-Temperature Ratings Class 150-LB (Pressure in PSIG)

Flange Material	Temperature °F (°C)													
	-20 to 100 (-28.9 to 37.8)	200 (93.3)	300 (148.9)	400 (204.4)	500 (260.0)	600 (315.6)	650 (343.3)	700 (371.1)	750 (398.9)	800 (426.7)	850 (454.4)	900 (482.2)	950 (510.0)	1000 (537.8)
A105 Steel	285	260	230	200	170	140	125	110	95	80	—	—	—	—
316 Stainless	275	240	215	195	170	140	125	110	95	80	65	50	35	20
304 Stainless	275	235	205	180	170	140	125	110	95	80	65	50	35	20

Checklist — Selecting the Proper Flanged Heater, *continued*

Select the Element Sheath Material

Sheath Material Selection

CORROSION. In addition to selecting a sheath material that is compatible with the heated medium, other factors that affect corrosion need to be considered:

- 1. The temperature of the corrodent** — As temperature increases the degree of corrosion increases. Also remember that usually the element temperature is higher than the material it is heating.
- 2. The degree of aeration to which a corrodent is exposed** — Stagnant conditions can deprive the stainless steels of oxygen, which is required to maintain their corrosion resistant surface.

- 3. Velocity of the corrodent** — Increased velocity can increase the corrosion rate.



Note: See pages 16-12 through 16-20 for the recommended sheath materials for many immersion heating applications. If you are purchasing the material you are heating, check with the supplier for their recommendations.

Standard Element Sheath Materials

Incoloy® 800 — A Nickel (30-35%), Chromium (19-23%), Iron alloy. The high nickel content of this alloy contributes to its resistance to scaling and corrosion. Used in air heating (also see Incoloy® 840) and immersion heating of potable water and other liquids that are not corrosive to an Incoloy® 800 sheath.

Low Carbon Steel — Applications include fluid heat transfer media, tar, high to low viscosity petroleum oils, asphalt, wax, molten salt, and other solutions not corrosive to a steel sheath.

316 Stainless Steel — A Chromium (16-18%), Nickel (11-14%), Iron Alloy with Molybdenum (2-3%) added to improve corrosion resistance in certain environments, especially those that would tend to cause pitting due to the presence of chlorides. Applications include deionized water.

Copper — Mainly used in clean water heating for washrooms, showers, rinse tanks and freeze protection of storage tanks.

Optional Element Sheath Materials

304 Stainless Steel — A Chromium (18-20%), Nickel (8-11%), Iron Alloy used in the food industry, sterilizing solutions, air heating and many organic and inorganic chemicals.

321 Stainless Steel — A Chromium (17-20%), Nickel (9-13%), Iron Alloy modified with the addition of titanium to prevent carbide precipitation and the resulting intergranular corrosion that can take place in certain mediums when operating in the 800-1200°F (427-649°C) temperature range.

Incoloy® 840 — A Nickel (18-20%), Chromium (18-22%), Iron alloy. Incoloy 840® has about 10% less nickel than Incoloy 800. Used in many air heating applications where it has exhibited superior oxidation resistance at less cost than Incoloy 800®.

Incoloy® 825 — A Nickel (38-46%), Chromium (19.5-23.5%), Molybdenum (2-3%) Iron alloy. Consult Tempco for more information.

Surface Treatments for Stainless Steel and Incoloy® Elements and other Wetted Parts to Improve Corrosion Resistance

Flanged Immersion Heater surfaces in contact with the material being heated can be passivated or electro-polished to improve their resistance to corrosion.

Passivation removes surface contamination, usually iron, so that the optimum corrosion resistance of the stainless steel is maintained. Surface contamination would come from the small amount of steel that may be worn off a tool during the manufacturing process. Passivating is accomplished by dipping the heater in a warm solution of nitric acid.

Electro-Polishing is an electrochemical process that removes surface imperfections and contaminants, enhancing the corrosion resisting ability of the stainless steels. The resultant surface is clean, smooth and bright. Many medical and food applications require this finish.

Select Optional Flange and Gasket Materials

Optional flange materials include:

- * 304, 304L Stainless Steel
- * 316L Stainless Steel
- * Incoloy® 800

Gaskets of different types, including spiral wound metal with non-metallic filler, are available to properly seal any flanged heater. Gasket material choice depends on operating conditions and fluid compatibility. Consult TEMPSCO for help with your selection.



CONTINUED

Checklist – Selecting the Proper Flanged Heater, *continued*

Select Standard Terminal Housing

Standard catalog flanged immersion heaters are supplied with the general purpose **Type 1N** (NEMA 1) terminal housing as shown below. If an optional thermostat is installed, the housing supplied is the **Type 1T** (NEMA 1). See pages 11-6 through 11-10 for thermostats and accessories.

Additional housing types for use with and without a thermostat include:

- Moisture Resistant** (NEMA 4)
- Explosion Resistant** (NEMA 7)
- Moisture/Explosion Resistant** (NEMA 4/7).

If the housings on this and the following page do not meet the size, construction or other criteria of your application, consult Tempco with your requirements.

Standard NEMA 1 Terminal Housings for all Size Flanges

TYPE 1N (For use with heaters having no thermostat)

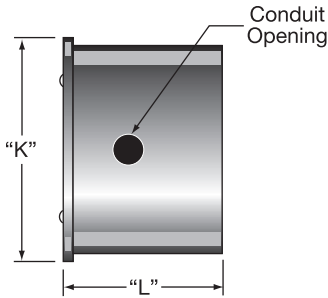

Flange Size	"K"		"L"		Conduit Opening
	in	mm	in	mm	
3	4-1/8	105	3-1/16	78	1-1/8
4	6	152	4	102	1-1/8
5	6-3/8	162	4	102	1-1/8
6	7-13/16	198	5-3/8	137	1-1/8
8	9-7/8	251	5-3/8	137	1-3/8
10	11-3/4	298	6	152	1-3/4
12	13-3/4	349	6	152	1-3/4
14	15-1/4	387	6	152	1-3/4

TYPE 1T (For use with heaters with a thermostat)

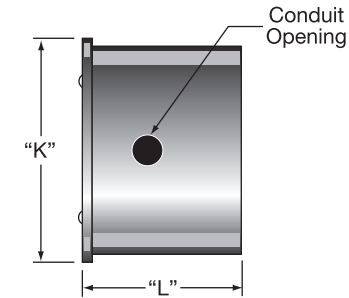

Flange Size	"K"		"L"		Conduit Opening
	in	mm	in	mm	
3	4-1/8	105	6	152	1-1/8
4	6	152	6	152	1-1/8
5	6-5/8	168	6	152	1-1/8
6	7-13/16	198	6	152	1-1/8
8	9-7/8	251	6	152	1-3/8
10	CALL TEMPCO				
12					
14					

Standard NEMA 4 and/or 7 Terminal Housings for 3" Flanges

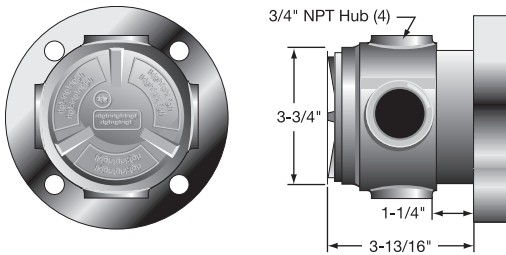

TYPE 2N (For use with heaters having no thermostat)

NEMA 4 rating requires the use of the cover gasket.

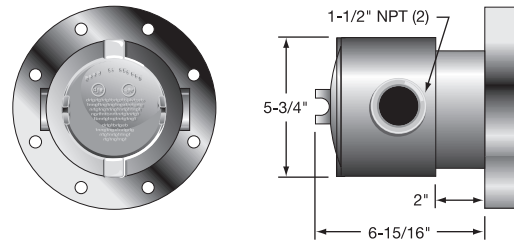

TYPE 2T (For use with heaters with thermostat)

NEMA 4 rating requires the use of the cover gasket.

Standard NEMA 4 and/or 7 Terminal Housings for 4" and 5" Flanges

TYPE 3N (heaters having no thermostat)

NEMA 4 rating requires the use of the cover gasket.

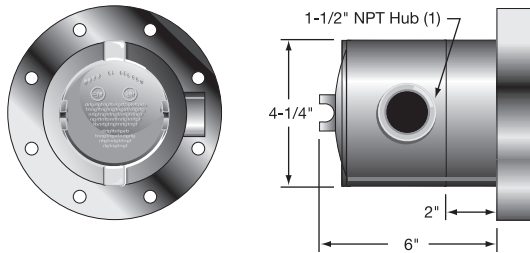

TYPE 3T (heaters with thermostat)

NEMA 4 rating requires the use of the cover gasket.

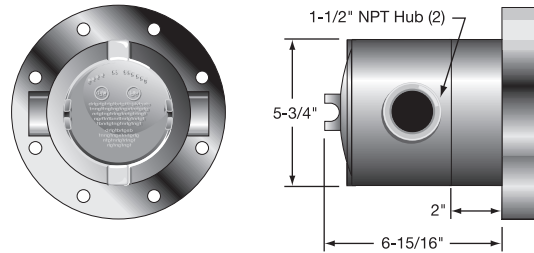

Standard NEMA 4 Terminal Housings for 6" through 14" Flanges

TYPE 4N (For use with heaters with no thermostat)

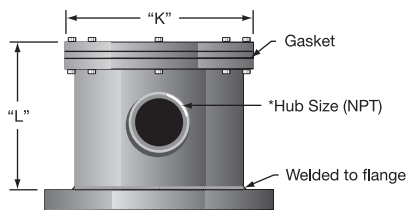

Flange Size	"K"		"L"		Hub Size (NPT)
	in	mm	in	mm	
6	8	203	6	152	2
8	10	254	6	152	2
10	13-3/4	349	6	152	2-1/2
12	15-5/8	397	6	152	2-1/2
14	17-1/4	438	6	152	2-1/2

TYPE 4T (For use with heaters with thermostat)

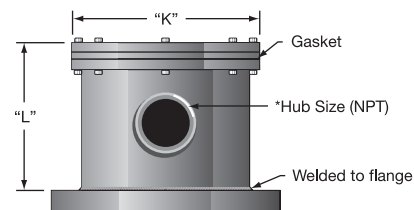

Flange Size	"K"		"L"		Hub Size (NPT)
	in	mm	in	mm	
6	8	203	6	152	2
8	10	254	6	152	2
10	13-3/4	349	7-1/2	191	2-1/2
12	15-5/8	397	7-1/2	191	2-1/2
14	17-1/4	438	7-1/2	191	2-1/2

Standard NEMA 7 Terminal Housings for 6" through 14" Flanges

TYPE 5N (For use with heaters with no thermostat)

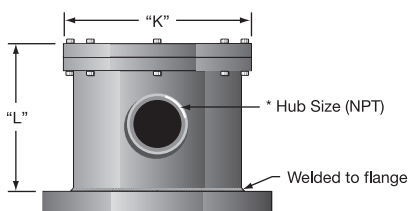

Flange Size	"K"		"L"		Hub Size (NPT)
	in	mm	in	mm	
6	9-3/8	203	6	152	2
8	11-1/2	254	6	152	2
10	13-3/4	349	6	152	2-1/2
12	13-5/8	397	6	152	2-1/2
14	17-1/2	438	6	152	2-1/2

TYPE 5T (For use with heaters with thermostat)

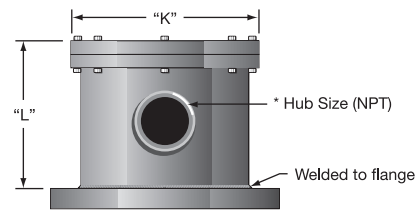

Flange Size	"K"		"L"		Hub Size (NPT)
	in	mm	in	mm	
6	9-3/8	203	7-1/2	191	2
8	11-1/2	254	7-1/2	191	2
10	13-3/4	349	7-1/2	191	2-1/2
12	13-5/8	397	7-1/2	191	2-1/2
14	17-1/2	438	7-1/2	191	2-1/2



Explosion resistant terminal housings are intended to provide containment of an explosion in the enclosure only. No portion of the heater assembly outside the enclosure is covered under this NEMA rating. Abnormal use of a heater which results in excessive temperature can create hazardous conditions such as a fire. Never perform any type of service nor remove the housing cover prior to disconnecting all electrical power to the heater.

Optional Terminal Housing Standoff Construction

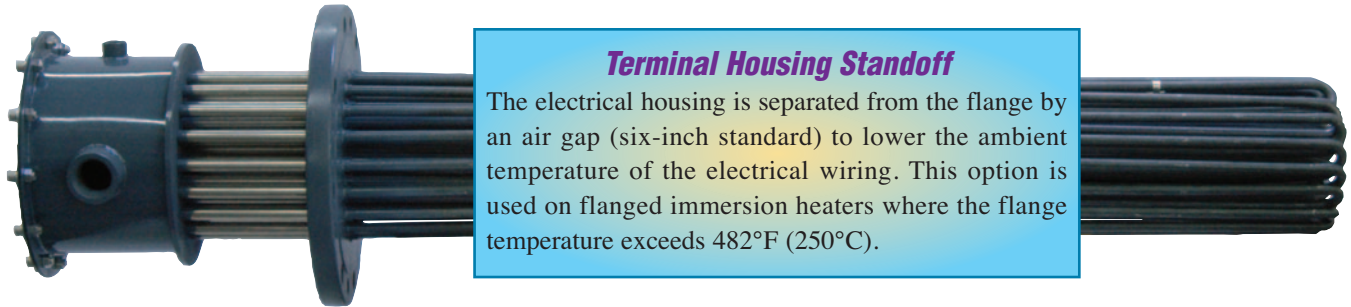

Optional Flanged Heater Features

Flow Control Baffles

For flange heaters used in circulation tanks, to aid heat transfer by forcing the liquid or gas back and forth across the elements. Baffles can be custom designed and positioned for your application.

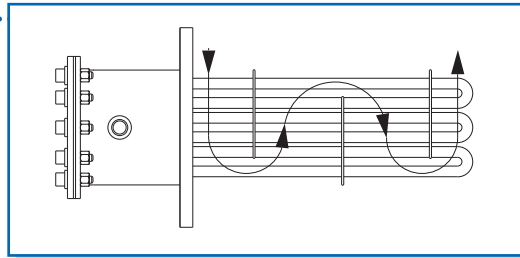

Temperature Control

Thermostats

Thermostats are an optional feature for flanged immersion heaters. This type of control operates by expansion and contraction of a liquid in response to temperature change. Liquid contained within the sensing bulb and capillary flexes a diaphragm, causing the opening and closing of a snap action switch. For heating applications the contacts are normally closed, and open on temperature rise.

Installation Warnings and Recommendations



1. Do not use the thermostat as a power switch. Use some other means of disconnecting power to the heater for servicing.
2. A thermostat is not a fail-safe device. Use an approved high temperature limit control and/or pressure limit control for safe operation.
3. Avoid kinking or bending the capillary tube too sharply as this will alter the calibration and/or render the thermostat inoperable.
4. Excess capillary tube should be coiled neatly in junction box.
5. The capillary tube must never touch the thermostat contacts as this will create an electrical short capable of harming personnel and/or equipment.

Thermocouples

Type J or Type K thermocouples can be supplied for process temperature or over-temperature control. Type J is reliable and accurate for temperatures up to 1000°F (537.8°C). Type K should be used for higher temperatures.

For measuring process temperatures, the thermocouple can be mounted in a thermowell in the center of the element bundle. Note that a location somewhere away from the heater may give a more accurate measurement of process temperature.

For over-temperature protection, the thermocouple is usually attached to one of the elements and any unusual rise in element temperature would shut the heater down. This thermocouple may also be mounted in a thermowell, which is then attached to one of the heating elements if desired. This protects the thermocouple from the solution being heated and allows you to replace it without removing the heater, but does increase its response time.

Temperature and over-temperature controls and how to choose the best control for your application can be found in Section 14.

Flanged Heater Installation and Maintenance

1. Immersion heaters should be positioned to insure they are completely covered with the liquid they are heating. However, do not position the unit too low in structures where sludge buildup could cover it. Either of these conditions could cause overheating and subsequent premature failure of the elements.
2. Heated section should start sufficiently inside tank to assure good heat transfer. On large tanks, use several smaller KW rated heaters rather than one large heater for uniform heat and watt density distribution.
3. Install adequate controls and safety devices to prevent build-up of temperature and/or pressure.
4. Make sure gasket surface is clean and dry before seating the heater.
5. Do not operate heater at a voltage in excess of that stamped on the heater. A heater can be run at a reduced voltage, remembering that this will decrease the heater's output wattage.
6. A wiring diagram is supplied in the electrical enclosure and as required, circuits on the heater are labeled.
7. All heater terminal connections should be wrench or screwdriver tight with maximum torque consistent with terminal strength. To prevent twisting heater terminals when tightening connections, use backup wrench for countertorque. Periodically check that electrical connections are clean and tight.
8. The electrical insulating material used in electric heaters is hygroscopic and may absorb moisture when subjected to a humid environment during shipping, while in storage or during long equipment shutdowns. This moisture may lower the insulation resistance enough to cause heater failure.
A meg-ohmmeter should be used to check the insulation resistance before applying power to any questionable heater.
If a moisture condition exists it can be corrected by baking the heater in an oven at approximately 350°F (176.7°C) until the moisture is expelled and the meg-ohms have risen to an acceptable level.
9. For heaters supplied with an integral thermostat, this thermostat functions as a temperature control only and is not a fail-safe device.
10. For TFP flanged heaters used in UL recognized oil heating applications:
 - The heated oil temperature cannot exceed 257°F (125°C)
 - TFP designs with ASA pressure rated flanges are UL rated to a maximum operating pressure of 150 psig
 - Steel sheath elements are limited to 60 watts/in²
 - Maximum Wattage/Voltage: 45KW/480V, in 5" and smaller flange sizes with 9 elements maximum

Contact Tempco for other application specific UL file information.

Quality Assured Through 100% Final Inspection

1. Resistance test — to verify wattage
2. Insulation test — to measure leakage current resistance
3. High voltage test — to “proof-test” the insulation against grounds and short circuits
4. Hydrostatic or air pressure testing — to leakproof test all welding of the elements to the flange

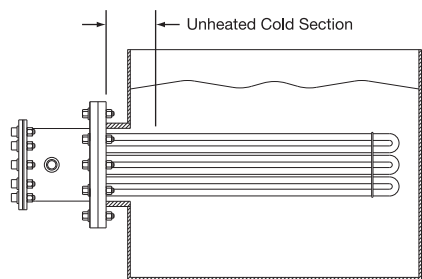

The tubular heating elements used in type TFP Flanged Immersion Heaters are UL component recognized and CSA certified in most design variations for general immersion heater use. The UL File Number is E90771 (CCN UBJY2/8) and the equivalent CSA File Number is 043099. They are also UL recognized under UL standard UL574 File Number MP4154 (CCN MDS2/8) for oil heating.

If you require UL, CSA, or other NRTL agency approvals, please specify when ordering.

Ordering Information

Catalog Heaters

Catalog Part Numbers are stocked as sub-assemblies for 2-3 week delivery.

Custom Engineered/Manufactured Heaters

An electric heater can be very application specific; for sizes and ratings not listed, **TEMPCO** will design and manufacture a Flanged Immersion Heater to meet your requirements. **Standard lead time is 4 weeks.**

Please Specify the following:

- | | |
|---|--|
| <input type="checkbox"/> Wattage, Voltage and Phase | <input type="checkbox"/> Element Immersion Length |
| <input type="checkbox"/> Flange Size and Material | <input type="checkbox"/> Electrical Enclosure Type |
| <input type="checkbox"/> Element Sheath Material | <input type="checkbox"/> Thermostat— if required |
| <input type="checkbox"/> Element Watt Density | <input type="checkbox"/> Optional Features |

⚠ WARNING: Cancer and Reproductive Harm - www.P65Warnings.ca.gov.



Flanged Immersion Heaters

Standard Flanged Immersion Heaters

8 watts/in² (1.3 watts/cm²) — Typical Applications: Fuel Oils (Bunker C and Number 6)

* 150-lb Raised Face Forged Carbon Steel Flange

* Steel Sheath Heating Elements

NOTE: Wired for 3-Phase only.

ANSI Flange Size	Immersed Length		KW	Part Number						Approximate Net Weight			
	in	mm		240V-1Ph	Circuits	240V-3Ph	Circuits	480V-1Ph	Circuits	480V-3Ph	Circuits	lbs	kgs
3" — 150lb 3 elements	33	838	2	—	—	TFP02001	(1)	—	—	TFP02002	(1)	18	8
	48	1219	3	—	—	TFP02003	(1)	—	—	TFP02004	(1)	21	10
	64½	1638	4	—	—	TFP02005	(1)	—	—	TFP02006	(1)	24	11
	77	1956	5	—	—	TFP02007	(1)	—	—	TFP02008	(1)	26	12
4" — 150lb 6 elements	40½	1029	5	—	—	TFP02009	(1)	—	—	TFP02010	(1)	35	16
	48	1219	6	—	—	TFP02011	(1)	—	—	TFP02012	(1)	38	17
	64½	1638	8	—	—	TFP02013	(1)	—	—	TFP02014	(1)	44	20
	77	1956	10	—	—	TFP02015	(1)	—	—	TFP02016	(1)	48	22
5" — 150lb 6 elements	40½	1029	5	—	—	TFP02017	(1)	—	—	TFP02018	(1)	39	18
	48	1219	6	—	—	TFP02019	(1)	—	—	TFP02020	(1)	42	19
	64½	1638	8	—	—	TFP02021	(1)	—	—	TFP02022	(1)	48	22
	77	1956	10	—	—	TFP02023	(1)	—	—	TFP02024	(1)	52	24
5" — 150lb 9 elements	40½	1029	7.5	—	—	TFP02025	(1)	—	—	TFP02026	(1)	46	21
	48	1219	9	—	—	TFP02027	(1)	—	—	TFP02028	(1)	50	23
	64½	1638	12	—	—	TFP02029	(1)	—	—	TFP02030	(1)	59	27
	77	1956	15	—	—	TFP02031	(1)	—	—	TFP02032	(1)	65	29
6" — 150lb 12 elements	32¾	835	8	—	—	TFP02033	(1)	—	—	TFP02034	(1)	56	25
	40¾	1026	10	—	—	TFP02035	(1)	—	—	TFP02036	(1)	61	28
	47¾	1216	12	—	—	TFP02037	(1)	—	—	TFP02038	(1)	66	30
	64¾	1635	16.5	—	—	TFP02039	(1)	—	—	TFP02040	(1)	78	35
	76¾	1953	20	—	—	TFP02041	(1)	—	—	TFP02042	(1)	86	39
6" — 150lb 15 elements	32¾	835	10	—	—	TFP02043	(1)	—	—	TFP02044	(1)	62	28
	40¾	1026	12.5	—	—	TFP02045	(1)	—	—	TFP02046	(1)	68	31
	47¾	1216	15	—	—	TFP02047	(1)	—	—	TFP02048	(1)	75	34
	64¾	1635	21	—	—	TFP02049	(5)	—	—	TFP02050	(1)	89	40
	76¾	1953	25	—	—	TFP02051	(5)	—	—	TFP02052	(1)	99	45
8" — 150lb 18 elements	43¼	1099	12.5	—	—	TFP02053	(1)	—	—	TFP02054	(1)	99	45
	51¼	1302	16.5	—	—	TFP02055	(1)	—	—	TFP02056	(1)	107	49
	61¼	1569	20	—	—	TFP02057	(1)	—	—	TFP02058	(1)	117	53
	70¼	1784	24	—	—	TFP02059	(2)	—	—	TFP02060	(1)	126	57
	79¼	2013	27	—	—	TFP02061	(2)	—	—	TFP02062	(1)	136	62
8" — 150lb 24 elements	43¼	1099	17	—	—	TFP02063	(1)	—	—	TFP02064	(1)	114	52
	51¼	1302	22	—	—	TFP02065	(2)	—	—	TFP02066	(1)	125	57
	61¼	1569	27	—	—	TFP02067	(2)	—	—	TFP02068	(1)	139	63
	70¼	1784	32	—	—	TFP02069	(2)	—	—	TFP02070	(1)	151	68
	79¼	2013	36	—	—	TFP02071	(2)	—	—	TFP02072	(1)	162	73
10" — 150lb 27 elements	51¼	1314	25	—	—	TFP02073	(3)	—	—	TFP02074	(1)	155	70
	62¼	1581	30	—	—	TFP02075	(3)	—	—	TFP02076	(1)	171	78
	70¼	1797	35	—	—	TFP02077	(3)	—	—	TFP02078	(1)	184	83
	78¼	2000	40	—	—	TFP02079	(3)	—	—	TFP02080	(1)	196	89
12" — 150lb 36 elements	51¾	1311	34	—	—	TFP02081	(2)	—	—	TFP02082	(1)	216	98
	62¾	1578	40	—	—	TFP02083	(2)	—	—	TFP02084	(1)	239	108
	70¾	1794	47	—	—	TFP02085	(3)	—	—	TFP02086	(2)	267	121
	78¾	1997	54	—	—	TFP02087	(3)	—	—	TFP02088	(2)	273	124
14" — 150lb 45 elements	51½	1308	42	—	—	TFP02089	(3)	—	—	TFP02090	(3)	282	128
	62	1575	50	—	—	TFP02091	(3)	—	—	TFP02092	(3)	309	140
	70½	1791	60	—	—	TFP02093	(3)	—	—	TFP02094	(3)	330	150
	78½	1994	67	—	—	TFP02095	(5)	—	—	TFP02096	(3)	351	159

NOTE: Flanges 8" and larger are 7 watts/in² (1.1 watts/cm²)

Standard Flanged Immersion Heaters

15 watts/in² (2.3 watts/cm²) — Typical Applications: Fuel Oils (Number 4&5)

* 150-lb Raised Face Forged Carbon Steel Flange

* Steel Sheath Heating Elements

ANSI Flange Size	Immersed Length		KW	Part Number								Approximate Net Weight	
	in	mm		240V-1Ph Circuits	240V-3Ph Circuits	480V-1Ph Circuits	480V-3Ph Circuits	lbs	kgs				
3" — 150lb 3 elements	25 ³ / ₁₆	640	3	TFP02097 (1)	TFP02098 (1)	TFP02099 (1)	TFP02100 (1)	17	8				
	33 ³ / ₁₆	840	4	TFP02101 (1)	TFP02102 (1)	TFP02103 (1)	TFP02104 (1)	18	8				
	48 ³ / ₁₆	1221	6	TFP02105 (1)	TFP02106 (1)	TFP02107 (1)	TFP02108 (1)	21	10				
5" — 150lb 6 elements	33 ³ / ₁₆	840	8	—	TFP02109 (1)	—	TFP02110 (1)	37	17				
	40 ³ / ₁₆	1030	10	—	TFP02111 (1)	—	TFP02112 (1)	39	18				
	48 ³ / ₁₆	1221	12	—	TFP02113 (1)	—	TFP02114 (1)	42	19				
	57 ³ / ₁₆	1449	15	—	TFP02115 (1)	—	TFP02116 (1)	45	20				
	68 ³ / ₁₆	1729	18	—	TFP02117 (1)	—	TFP02118 (1)	49	22				
8" — 150lb 18 elements	32 ³ / ₈	835	20	—	TFP02119 (1)	—	TFP02120 (1)	89	40				
	43 ³ / ₁₆	1110	25	—	TFP02121 (2)	—	TFP02122 (1)	100	45				
	51 ³ / ₈	1318	30	—	TFP02123 (2)	—	TFP02124 (1)	108	49				
	61 ³ / ₈	1559	35	—	TFP02125 (2)	—	TFP02126 (1)	118	54				
	69 ³ / ₈	1775	40	—	TFP02127 (2)	—	TFP02128 (1)	125	57				
	78 ³ / ₈	2003	45	—	TFP02129 (3)	—	TFP02130 (2)	135	61				

NOTE: Flanges 8" and larger are 12 watts/in² (1.9 watts/cm²)

Flange Heater Dimensions

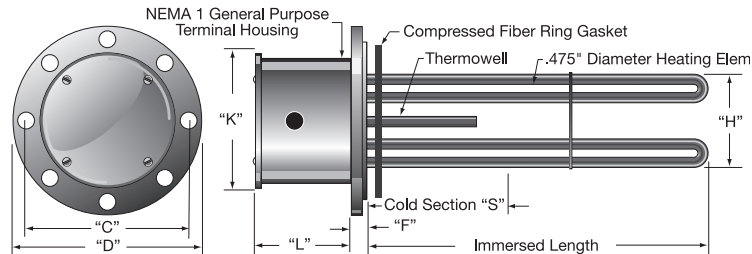

Flange size in	Flange Mounting		Flange Thickness "F"		Mounting Bolt Circle "C"		Flange Diameter "D"		Cold Section "S"		Bundle Diameter "H"		NEMA 1 Housing		Number of Elements			
	Hole Size in	No.	in	mm	in	mm	in	mm	in	mm	in	mm	in	mm	Std.	Max.		
3	3/4	4	15/16	24	6	152	7-1/2	191	4	102	2-3/4	70	4-5/8	117	2-5/8	67	3	6
4	3/4	8	15/16	24	7-1/2	191	9	229	4	102	3-7/8	98	6	152	4	102	6	6
5	7/8	8	15/16	24	8-1/2	216	10	254	4	102	5	127	7	178	4	102	6	9
6	7/8	8	1	25	9-1/2	241	11	279	4	102	6	152	8	203	6	152	12	15
8	7/8	8	1-1/8	29	11-3/4	298	13-1/2	343	6	152	7-13/16	198	10	254	6	152	18	24
10	1	12	1-3/16	30	14-1/4	362	16	406	6	152	9-3/4	248	11-5/8	295	6	152	27	36
12	1	12	1-1/4	32	17	432	19	483	6	152	11-3/4	298	13-1/2	343	6	152	36	54
14	1-1/8	12	1-3/8	35	18-3/4	476	21	533	6	152	12-3/4	324	15-1/8	384	6	152	45	72

Ordering Information

See Page 11-31 for complete Ordering Information.



Flanged Immersion Heaters

Standard Flanged Immersion Heaters

23 watts/in² (3.6 watts/cm²) — Typical Applications: Lightweight Oils • Heat Transfer Oils • Degreasing Solutions

* 150-lb Raised Face Forged Carbon Steel Flange

* Steel Sheath Heating Elements

ANSI Flange Size	Immersed Length		KW	Part Number								Approximate Net Weight	
	in	mm		240V-1Ph	Circuits	240V-3Ph	Circuits	480V-1Ph	Circuits	480V-3Ph	Circuits	lbs	kgs
3" — 150lb 3 elements	18	457	3	TFP02131	(1)	TFP02132	(1)	TFP02133	(1)	TFP02134	(1)	16	7
	25½	648	4.5	TFP02135	(1)	TFP02136	(1)	TFP02137	(1)	TFP02138	(1)	17	8
	33	838	6	TFP02139	(1)	TFP02140	(1)	TFP02141	(1)	TFP02142	(1)	18	8
	40½	1029	7.5	TFP02143	(1)	TFP02144	(1)	TFP02145	(1)	TFP02146	(1)	19	9
	48	1219	9	TFP02147	(1)	TFP02148	(1)	TFP02149	(1)	TFP02150	(1)	21	10
	64½	1638	12.5	—	—	TFP02151	(1)	TFP02152	(1)	TFP02153	(1)	24	11
	77	1956	15	—	—	TFP02154	(1)	TFP02155	(1)	TFP02156	(1)	26	12
4" — 150lb 6 elements	18	457	6	TFP02157	(1)	TFP02158	(1)	TFP02159	(1)	TFP02160	(1)	28	13
	25½	648	9	TFP02161	(1)	TFP02162	(1)	TFP02163	(1)	TFP02164	(1)	30	14
	33	838	12	TFP02165	(2)	TFP02166	(1)	TFP02167	(1)	TFP02168	(1)	33	15
	40½	1029	15	TFP02169	(2)	TFP02170	(1)	TFP02171	(1)	TFP02172	(1)	35	16
	48	1219	18	TFP02173	(2)	TFP02174	(1)	TFP02175	(1)	TFP02176	(1)	38	17
	64½	1638	25	—	—	TFP02177	(2)	TFP02178	(2)	TFP02179	(1)	44	20
	77	1956	30	—	—	TFP02180	(2)	TFP02181	(2)	TFP02182	(1)	48	22
5" — 150lb 6 elements	18	457	6	TFP02183	(1)	TFP02184	(1)	TFP02185	(1)	TFP02186	(1)	32	15
	25½	648	9	TFP02187	(1)	TFP02188	(1)	TFP02189	(1)	TFP02190	(1)	34	15
	33	838	12	TFP02191	(2)	TFP02192	(1)	TFP02193	(1)	TFP02194	(1)	37	17
	40½	1029	15	TFP02195	(2)	TFP02196	(1)	TFP02197	(1)	TFP02198	(1)	39	18
	48	1219	18	TFP02199	(2)	TFP02200	(1)	TFP02201	(1)	TFP02202	(1)	42	19
	52½	1322	20	TFP02203	(2)	TFP02204	(1)	TFP02205	(1)	TFP02206	(1)	43	20
	64½	1638	25	—	—	TFP02207	(2)	TFP02208	(2)	TFP02209	(1)	48	22
77	1956	30	—	—	TFP02210	(2)	TFP02211	(2)	TFP02212	(1)	52	24	
5" — 150lb 9 elements	18	457	9	TFP02213	(1)	TFP02214	(1)	TFP02215	(1)	TFP02216	(1)	35	16
	25½	648	14	TFP02217	(3)	TFP02218	(1)	TFP02219	(1)	TFP02220	(1)	39	18
	33	838	18	TFP02221	(3)	TFP02222	(1)	TFP02223	(1)	TFP02224	(1)	43	20
	40½	1029	23	TFP02225	(3)	TFP02226	(3)	TFP02227	(1)	TFP02228	(1)	46	21
	48	1219	27	TFP02229	(3)	TFP02230	(3)	TFP02231	(3)	TFP02232	(1)	50	23
	64½	1638	38	—	—	TFP02233	(3)	TFP02234	(3)	TFP02235	(1)	59	27
	77	1956	45	—	—	TFP02236	(3)	TFP02237	(3)	TFP02238	(3)	65	30
6" — 150lb 12 elements	17½	454	12	TFP02239	(1)	TFP02240	(1)	TFP02241	(1)	TFP02242	(1)	46	21
	25½	645	18	TFP02243	(2)	TFP02244	(1)	TFP02245	(1)	TFP02246	(1)	51	23
	32¾	835	24	TFP02247	(2)	TFP02248	(2)	TFP02249	(1)	TFP02250	(1)	56	25
	40¾	1026	30	TFP02251	(2)	TFP02252	(2)	TFP02253	(2)	TFP02254	(1)	61	28
	47¾	1216	36	TFP02255	(3)	TFP02256	(2)	TFP02257	(2)	TFP02258	(1)	66	30
	64¾	1635	50	—	—	TFP02259	(4)	TFP02260	(4)	TFP02261	(2)	78	35
	76¾	1953	60	—	—	TFP02262	(4)	TFP02263	(4)	TFP02264	(2)	86	39
6" — 150lb 15 elements	17½	454	15	TFP02265	(3)	TFP02266	(1)	TFP02267	(1)	TFP02268	(1)	49	22
	25½	645	23	TFP02269	(3)	TFP02270	(5)	TFP02271	(1)	TFP02272	(1)	55	25
	32¾	835	30	TFP02273	(3)	TFP02274	(5)	TFP02275	(3)	TFP02276	(1)	62	28
	40¾	1026	38	TFP02277	(5)	TFP02278	(5)	TFP02279	(3)	TFP02280	(1)	68	31
	47¾	1216	45	TFP02281	(5)	TFP02282	(5)	TFP02283	(3)	TFP02284	(5)	75	34
	64¾	1635	63	—	—	TFP02285	(5)	TFP02286	(3)	TFP02287	(5)	89	40
	76¾	1953	75	—	—	TFP02288	(5)	TFP02289	(5)	TFP02290	(5)	99	45
8" — 150lb 18 elements	32¾	832	30	TFP02291	(3)	TFP02292	(2)	TFP02293	(2)	TFP02294	(1)	88	40
	43¼	1099	40	—	—	TFP02295	(2)	TFP02296	(2)	TFP02297	(1)	99	45
	51¼	1302	50	—	—	TFP02298	(3)	TFP02299	(3)	TFP02300	(2)	107	49
	61¼	1568	60	—	—	TFP02301	(3)	TFP02302	(3)	TFP02303	(2)	117	53
	70¼	1784	70	—	—	TFP02304	(6)	TFP02305	(3)	TFP02306	(2)	126	57
	79¼	2013	80	—	—	TFP02307	(6)	—	—	TFP02308	(2)	136	62
	—	—	—	—	—	—	—	—	—	—	—	—	—
8" — 150lb 24 elements	32¾	832	40	TFP02309	(4)	TFP02310	(2)	TFP02311	(2)	TFP02312	(1)	100	45
	43¼	1099	53	—	—	TFP02313	(4)	TFP02314	(3)	TFP02315	(2)	114	52
	51¼	1302	67	—	—	TFP02316	(4)	TFP02317	(3)	TFP02318	(2)	125	57
	61¼	1568	80	—	—	TFP02319	(4)	TFP02320	(4)	TFP02321	(2)	139	63
	70¼	1784	93	—	—	TFP02322	(8)	TFP02323	(6)	TFP02324	(4)	151	68
	79¼	2013	107	—	—	TFP02325	(8)	—	—	TFP02326	(4)	162	73
	—	—	—	—	—	—	—	—	—	—	—	—	—

NOTE: Flanges 8" and larger are 20 watts/in² (3.1 watts/cm²)



Standard Flanged Immersion Heaters

Continued from previous page...

23 watts/in² (3.6 watts/cm²) — Typical Applications: Lightweight Oils • Heat Transfer Oils • Degreasing Solutions

* 150-lb Raised Face Forged Carbon Steel Flange

* Steel Sheath Heating Elements

ANSI Flange Size	Immersed Length		KW	Part Number								Approximate Net Weight	
	in	mm		240V-1Ph	Circuits	240V-3Ph	Circuits	480V-1Ph	Circuits	480V-3Ph	Circuits	lbs	kg
10" — 150lb 27 elements	33¼	845	45	—	—	TFP02327	(3)	—	—	TFP02328	(3)	127	58
	43¼	1111	60	—	—	TFP02329	(3)	—	—	TFP02330	(3)	143	65
	51¼	1314	75	—	—	TFP02331	(9)	—	—	TFP02332	(3)	155	70
	62¼	1581	90	—	—	—	—	—	—	TFP02333	(3)	171	78
	70¼	1797	105	—	—	—	—	—	—	TFP02334	(3)	184	83
	78¼	2000	120	—	—	—	—	—	—	TFP02335	(3)	196	89
12" — 150lb 36 elements	33⅝	841	60	—	—	—	—	—	—	TFP02336	(3)	180	82
	43⅝	1108	80	—	—	—	—	—	—	TFP02337	(3)	201	91
	51⅝	1311	100	—	—	—	—	—	—	TFP02338	(3)	216	98
	62⅝	1578	120	—	—	—	—	—	—	TFP02339	(3)	239	108
	70⅝	1794	140	—	—	—	—	—	—	TFP02340	(4)	267	121
	78⅝	1997	160	—	—	—	—	—	—	TFP02341	(4)	273	124
14" — 150lb 45 elements	33	838	75	—	—	—	—	—	—	TFP02342	(3)	235	107
	43½	1105	100	—	—	—	—	—	—	TFP02343	(3)	262	119
	51½	1308	125	—	—	—	—	—	—	TFP02344	(5)	282	128
	62	1575	150	—	—	—	—	—	—	TFP02345	(5)	309	140
	70½	1791	175	—	—	—	—	—	—	TFP02346	(5)	330	150
	78½	1994	200	—	—	—	—	—	—	TFP02347	(5)	351	159

NOTE: Flanges 8" and larger are 20 watts/in² (3.1 watts/cm²)

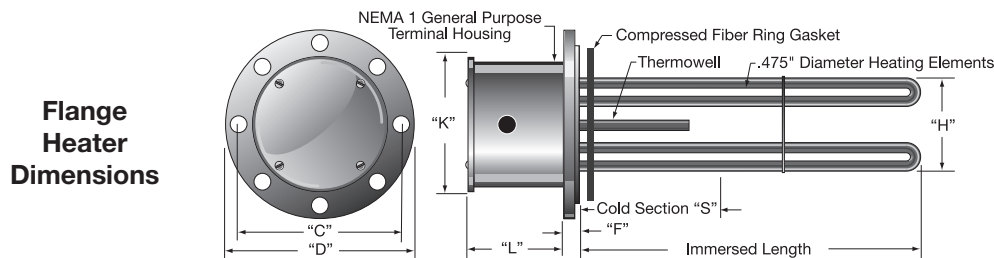

Flange size in	Flange Mounting		Flange Thickness "F"		Mounting Bolt Circle "C"		Flange Diameter "D"		Cold Section "S"		Bundle Diameter "H"		NEMA 1 Housing		Number of Elements				
	Hole Size in	No.	in	mm	in	mm	in	mm	in	mm	in	mm	"K" in	"L" in	Std.	Max.			
3	3/4	19	4	15/16	24	6	152	7-1/2	191	4	102	2-3/4	70	4-5/8	117	2-5/8	67	3	6
4	3/4	19	8	15/16	24	7-1/2	191	9	229	4	102	3-7/8	98	6	152	4	102	6	6
5	7/8	22	8	15/16	24	8-1/2	216	10	254	4	102	5	127	7	178	4	102	6	9
6	7/8	22	8	1	25	9-1/2	241	11	279	4	102	6	152	8	203	6	152	12	15
8	7/8	22	8	1-1/8	29	11-3/4	298	13-1/2	343	6	152	7-13/16	198	10	254	6	152	18	24
10	1	25	12	1-3/16	30	14-1/4	362	16	406	6	152	9-3/4	248	11-5/8	295	6	152	27	36
12	1	25	12	1-1/4	32	17	432	19	483	6	152	11-3/4	298	13-1/2	343	6	152	36	54
14	1-1/8	29	12	1-3/8	35	18-3/4	476	21	533	6	152	12-3/4	324	15-1/8	384	6	152	45	72

Ordering Information

See Page 11-31 for complete Ordering Information.



Flanged Immersion Heaters

Standard Flanged Immersion Heaters

16 watts/in² (2.5 watts/cm²) — Typical Applications: Heat Transfer Oils • Liquid Paraffin

* 150-lb Raised Face Forged Carbon Steel Flange

* Incoloy®800 sheath heating elements

NOTE: 3-Phase only. Cannot be rewired for single phase.

ANSI Flange Size	Immersed Length		KW	Part Number						Approximate Net Weight			
	in	mm		240V-1Ph	Circuits	240V-3Ph	Circuits	480V-1Ph	Circuits	480V-3Ph	Circuits	lbs	kgs
3" — 150lb 3 elements	13½	343	1.5	—	—	TFP02348	(1)	—	—	TFP02349	(1)	15	7
	18	457	2	—	—	TFP02350	(1)	—	—	TFP02351	(1)	16	7
	20½	521	2.5	—	—	TFP02352	(1)	—	—	TFP02353	(1)	16	7
	25½	648	3	—	—	TFP02354	(1)	—	—	TFP02355	(1)	17	8
	33	838	4	—	—	TFP02356	(1)	—	—	TFP02357	(1)	18	8
	40½	1029	5	—	—	TFP02358	(1)	—	—	TFP02359	(1)	19	9
	48	1219	6	—	—	TFP02360	(1)	—	—	TFP02361	(1)	21	10
4" — 150lb 6 elements	13½	343	3	—	—	TFP02362	(1)	—	—	TFP02363	(1)	26	12
	18	457	4	—	—	TFP02364	(1)	—	—	TFP02365	(1)	28	13
	20½	521	5	—	—	TFP02366	(1)	—	—	TFP02367	(1)	29	13
	25½	648	6	—	—	TFP02368	(1)	—	—	TFP02369	(1)	30	14
	33	838	8	—	—	TFP02370	(1)	—	—	TFP02371	(1)	33	15
	40½	1029	10	—	—	TFP02372	(1)	—	—	TFP02373	(1)	35	16
	48	1219	12	—	—	TFP02374	(1)	—	—	TFP02375	(1)	38	17
5" — 150lb 6 elements	13½	343	3	—	—	TFP02376	(1)	—	—	TFP02377	(1)	30	14
	18	457	4	—	—	TFP02378	(1)	—	—	TFP02379	(1)	32	15
	20½	521	5	—	—	TFP02380	(1)	—	—	TFP02381	(1)	33	15
	25½	648	6	—	—	TFP02382	(1)	—	—	TFP02383	(1)	34	15
	33	838	8	—	—	TFP02384	(1)	—	—	TFP02385	(1)	37	17
	40½	1029	10	—	—	TFP02386	(1)	—	—	TFP02387	(1)	39	18
	48	1219	12	—	—	TFP02388	(1)	—	—	TFP02389	(1)	42	19
5" — 150lb 9 elements	13½	343	4.5	—	—	TFP02390	(1)	—	—	TFP02391	(1)	33	15
	18	457	6	—	—	TFP02392	(1)	—	—	TFP02393	(1)	35	16
	20½	521	7.5	—	—	TFP02394	(1)	—	—	TFP02395	(1)	36	16
	25½	648	9	—	—	TFP02396	(1)	—	—	TFP02397	(1)	39	18
	33	838	12	—	—	TFP02398	(1)	—	—	TFP02399	(1)	43	20
	40½	1029	15	—	—	TFP02400	(1)	—	—	TFP02401	(1)	46	21
	48	1219	18	—	—	TFP02402	(1)	—	—	TFP02403	(1)	50	23
6" — 150lb 12 elements	13½	340	6	—	—	TFP02404	(1)	—	—	TFP02405	(1)	43	20
	17⅞	454	8	—	—	TFP02406	(1)	—	—	TFP02407	(1)	46	21
	20¾	518	10	—	—	TFP02408	(1)	—	—	TFP02409	(1)	48	22
	25⅞	645	12	—	—	TFP02410	(1)	—	—	TFP02411	(1)	51	23
	32⅞	835	16	—	—	TFP02412	(1)	—	—	TFP02413	(1)	56	25
	40⅞	1026	20	—	—	TFP02414	(1)	—	—	TFP02415	(1)	61	28
	47⅞	1216	24	—	—	TFP02416	(2)	—	—	TFP02417	(1)	66	30
6" — 150lb 15 elements	13⅞	340	7.5	—	—	TFP02418	(1)	—	—	TFP02419	(1)	45	20
	17⅞	454	10	—	—	TFP02420	(1)	—	—	TFP02421	(1)	49	22
	20¾	518	12.5	—	—	TFP02422	(1)	—	—	TFP02423	(1)	51	23
	25¾	645	15	—	—	TFP02424	(1)	—	—	TFP02425	(1)	55	25
	32¾	835	20	—	—	TFP02426	(5)	—	—	TFP02427	(1)	62	28
	40¾	1026	25	—	—	TFP02428	(5)	—	—	TFP02429	(1)	68	31
	47¾	1216	30	—	—	TFP02430	(5)	—	—	TFP02431	(1)	75	34
8" — 150lb 18 elements	25¼	654	17	—	—	TFP02432	(1)	—	—	TFP02433	(1)	81	37
	35¼	908	25	—	—	TFP02434	(2)	—	—	TFP02435	(1)	91	41
	44¼	1124	33	—	—	TFP02436	(2)	—	—	TFP02437	(1)	100	45
	54¼	1378	42	—	—	TFP02438	(3)	—	—	TFP02439	(2)	110	50
	63¼	1607	50	—	—	—	—	—	—	TFP02440	(2)	119	54
	72¼	1848	58	—	—	—	—	—	—	TFP02441	(2)	129	59
	82¼	2089	67	—	—	—	—	—	—	TFP02442	(2)	139	63
8" — 150lb 24 elements	25¼	654	23	—	—	TFP02443	(2)	—	—	TFP02444	(1)	90	41
	35¼	908	33	—	—	TFP02445	(2)	—	—	TFP02446	(1)	104	47
	44¼	1124	44	—	—	TFP02447	(4)	—	—	TFP02448	(2)	115	52
	54¼	1378	56	—	—	TFP02449	(4)	—	—	TFP02450	(2)	129	59
	63¼	1607	67	—	—	—	—	—	—	TFP02451	(2)	141	64
	72¼	1848	77	—	—	—	—	—	—	TFP02452	(2)	154	70
	82¼	2089	89	—	—	—	—	—	—	TFP02453	(4)	167	76

CONTINUED



Standard Flanged Immersion Heaters

Continued from previous page...

16 watts/in² (2.5 watts/cm²) — Typical Applications: Heat Transfer Oils • Liquid Paraffin

* 150-lb Raised Face Forged Carbon Steel Flange

* Incoloy®800 sheath heating elements

NOTE: 3-Phase only. Cannot be rewired for single phase.

ANSI Flange Size	Immersed Length		KW	Part Number				Approximate Net Weight	
	in	mm		240V-1Ph Circuits	240V-3Ph Circuits	480V-1Ph Circuits	480V-3Ph Circuits	lbs	kgs
10" — 150lb 27 elements	54 ³ / ₄	1391	63	—	—	—	TFP02454 (3)	160	73
	63 ³ / ₄	1619	75	—	—	—	TFP02455 (3)	173	78
	73 ³ / ₄	1861	87	—	—	—	TFP02456 (3)	188	85
12" — 150lb 36 elements	54 ⁷ / ₈	1387	83	—	—	—	TFP02457 (3)	224	102
	63 ³ / ₄	1619	100	—	—	—	TFP02458 (3)	242	110
	73 ⁷ / ₈	1857	117	—	—	—	TFP02459 (3)	262	119
14" — 150lb 45 elements	54 ¹ / ₂	1384	105	—	—	—	TFP02460 (3)	290	132
	63 ¹ / ₂	1613	125	—	—	—	TFP02461 (5)	313	142

Flange Heater Dimensions

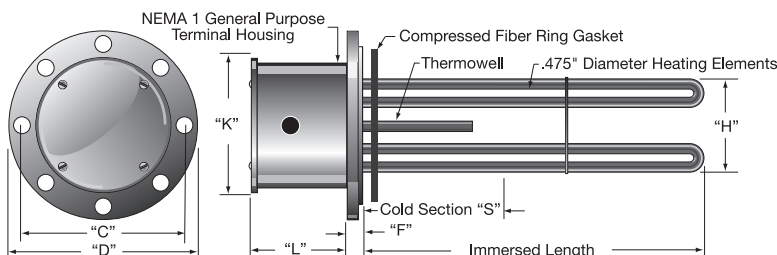

Flange size in	Flange Mounting		Flange Thickness "F"		Mounting Bolt Circle "C"		Flange Diameter "D"		Cold Section "S"		Bundle Diameter "H"		NEMA 1 Housing		Number of Elements			
	Hole Size in	No.	in	mm	in	mm	in	mm	in	mm	in	mm	in	mm	Std.	Max.		
3	3/4	4	15/16	24	6	152	7-1/2	191	4	102	2-3/4	70	4-5/8	117	2-5/8	67	3	6
4	3/4	8	15/16	24	7-1/2	191	9	229	4	102	3-7/8	98	6	152	4	102	6	6
5	7/8	8	15/16	24	8-1/2	216	10	254	4	102	5	127	7	178	4	102	6	9
6	7/8	8	1	25	9-1/2	241	11	279	4	102	6	152	8	203	6	152	12	15
8	7/8	8	1-1/8	29	11-3/4	298	13-1/2	343	6	152	7-13/16	198	10	254	6	152	18	24
10	1	12	1-3/16	30	14-1/4	362	16	406	6	152	9-3/4	248	11-5/8	295	6	152	27	36
12	1	12	1-1/4	32	17	432	19	483	6	152	11-3/4	298	13-1/2	343	6	152	36	54
14	1-1/8	12	1-3/8	35	18-3/4	476	21	533	6	152	12-3/4	324	15-1/8	384	6	152	45	72

Ordering Information

See Page 11-31 for complete Ordering Information.



Flanged Immersion Heaters

Standard Flanged Immersion Heaters

23 watts/in² (3.6 watts/cm²) — Typical Applications: Forced Air • Caustic Solutions • Degreasing Solutions

* 150-lb Raised Face Forged Carbon Steel Flange

* Incoloy[®]800 Sheath Heating Elements

ANSI Flange Size	Immersed Length		KW	Part Number								Approximate Net Weight	
	in	mm		240V-1Ph	Circuits	240V-3Ph	Circuits	480V-1Ph	Circuits	480V-3Ph	Circuits	lbs	kgs
3" — 150lb 3 elements	18	457	3	TFP02462	(1)	TFP02463	(1)	TFP02464	(1)	TFP02465	(1)	16	7
	25½	648	4.5	TFP02466	(1)	TFP02467	(1)	TFP02468	(1)	TFP02469	(1)	17	8
	33	838	6	TFP02470	(1)	TFP02471	(1)	TFP02472	(1)	TFP02473	(1)	18	8
	40½	1029	7.5	TFP02474	(1)	TFP02475	(1)	TFP02476	(1)	TFP02477	(1)	19	9
	48	1219	9	TFP02478	(1)	TFP02479	(1)	TFP02480	(1)	TFP02481	(1)	21	10
	64½	1638	12.5	—	—	TFP02482	(1)	TFP02483	(1)	TFP02484	(1)	24	11
	77	1956	15	—	—	TFP02485	(1)	TFP02486	(1)	TFP02487	(1)	26	12
4" — 150lb 6 elements	18	457	6	TFP02488	(1)	TFP02489	(1)	TFP02490	(1)	TFP02491	(1)	28	13
	25½	648	9	TFP02492	(1)	TFP02493	(1)	TFP02494	(1)	TFP02495	(1)	30	14
	33	838	12	TFP02496	(2)	TFP02497	(1)	TFP02498	(1)	TFP02499	(1)	33	15
	40½	1029	15	TFP02500	(2)	TFP02501	(1)	TFP02502	(1)	TFP02503	(1)	35	16
	48	1219	18	TFP02504	(2)	TFP02505	(1)	TFP02506	(1)	TFP02507	(1)	38	17
	64½	1638	25	—	—	TFP02508	(2)	TFP02509	(2)	TFP02510	(1)	44	20
	77	1956	30	—	—	TFP02511	(2)	TFP02512	(2)	TFP02513	(1)	48	22
5" — 150lb 6 elements	18	457	6	TFP02514	(1)	TFP02515	(1)	TFP02516	(1)	TFP02517	(1)	32	15
	25½	648	9	TFP02518	(1)	TFP02519	(1)	TFP02520	(1)	TFP02521	(1)	34	15
	33	838	12	TFP02522	(2)	TFP02523	(1)	TFP02524	(1)	TFP02525	(1)	37	17
	40½	1029	15	TFP02526	(2)	TFP02527	(1)	TFP02528	(1)	TFP02529	(1)	39	18
	48	1219	18	TFP02530	(2)	TFP02531	(1)	TFP02532	(1)	TFP02533	(1)	42	19
	64½	1638	25	—	—	TFP02534	(2)	TFP02535	(2)	TFP02536	(1)	48	22
	77	1956	30	—	—	TFP02537	(2)	TFP02538	(2)	TFP02539	(1)	52	24
5" — 150lb 9 elements	18	457	9	TFP02540	(1)	TFP02541	(1)	TFP02542	(1)	TFP02543	(1)	35	16
	25½	648	14	TFP02544	(3)	TFP02545	(1)	TFP02546	(1)	TFP02547	(1)	39	18
	33	838	18	TFP02548	(3)	TFP02549	(1)	TFP02550	(1)	TFP02551	(1)	43	20
	40½	1029	23	TFP02552	(3)	TFP02553	(3)	TFP02554	(1)	TFP02555	(1)	46	21
	48	1219	27	TFP02556	(3)	TFP02557	(3)	TFP02558	(3)	TFP02559	(1)	50	23
	64½	1638	38	—	—	TFP02560	(3)	TFP02561	(3)	TFP02562	(1)	59	27
	77	1956	45	—	—	TFP02563	(3)	TFP02564	(3)	TFP02565	(3)	65	30
6" — 150lb 12 elements	17⅞	454	12	TFP02566	(2)	TFP02567	(1)	TFP02568	(1)	TFP02569	(1)	46	21
	25⅜	645	18	TFP02570	(2)	TFP02571	(1)	TFP02572	(1)	TFP02573	(1)	51	23
	32⅜	835	24	TFP02574	(2)	TFP02575	(2)	TFP02576	(2)	TFP02577	(1)	56	25
	40⅜	1026	30	TFP02578	(3)	TFP02579	(2)	TFP02580	(2)	TFP02581	(1)	61	28
	47⅞	1216	36	TFP02582	(3)	TFP02583	(2)	TFP02584	(2)	TFP02585	(1)	66	30
	64⅜	1635	50	—	—	TFP02586	(4)	TFP02587	(3)	TFP02588	(2)	78	35
	76⅞	1953	60	—	—	TFP02589	(4)	TFP02590	(3)	TFP02591	(2)	86	39
6" — 150lb 15 elements	17⅞	454	15	TFP02592	(3)	TFP02593	(1)	TFP02594	(1)	TFP02595	(1)	49	22
	25⅜	645	23	TFP02596	(3)	TFP02597	(5)	TFP02598	(1)	TFP02599	(1)	55	25
	32⅜	835	30	TFP02600	(3)	TFP02601	(5)	TFP02602	(3)	TFP02603	(1)	62	28
	40⅜	1026	38	TFP02604	(5)	TFP02605	(5)	TFP02606	(3)	TFP02607	(1)	68	31
	47⅞	1216	45	TFP02608	(5)	TFP02609	(5)	TFP02610	(3)	TFP02611	(5)	75	34
	64⅜	1635	63	—	—	TFP02612	(5)	TFP02613	(3)	TFP02614	(5)	89	40
	76⅞	1953	75	—	—	TFP02615	(5)	TFP02616	(5)	TFP02617	(5)	99	45

CONTINUED

Standard Flanged Immersion Heaters

Continued from previous page...

23 watts/in² (3.6 watts/cm²) — Typical Applications: Forced Air • Caustic Solutions • Degreasing Solutions

* 150-lb Raised Face Forged Carbon Steel Flange

* Incoloy® 800 Sheath Heating Elements

ANSI Flange Size	Immersed Length		KW	Part Number								Approximate Net Weight	
	in	mm		240V-1Ph	Circuits	240V-3Ph	Circuits	480V-1Ph	Circuits	480V-3Ph	Circuits	lbs	kgs
8" — 150lb 18 elements	32¾	832	30	TFP02618	(3)	TFP02619	(2)	TFP02620	(2)	TFP02621	(1)	88	40
	43¾	1099	40	—	—	TFP02622	(2)	TFP02623	(2)	TFP02624	(1)	99	45
	51¼	1302	50	—	—	TFP02625	(3)	TFP02626	(3)	TFP02627	(2)	107	49
8" — 150lb 24 elements	32¾	832	40	TFP02628	(4)	TFP02629	(2)	TFP02630	(2)	TFP02631	(1)	100	45
	43¾	1099	53	—	—	TFP02632	(4)	TFP02633	(3)	TFP02634	(2)	115	52
	51¼	1302	67	—	—	TFP02635	(4)	TFP02636	(3)	TFP02637	(2)	125	57
10" — 150lb 27 elements	33¾	845	45	—	—	TFP02638	(3)	—	—	TFP02639	(3)	127	58
	43¾	1111	60	—	—	TFP02640	(3)	—	—	TFP02641	(3)	143	65
	51¾	1314	75	—	—	TFP02642	(9)	—	—	TFP02643	(3)	155	70
12" — 150lb 36 elements	33⅝	841	60	—	—	—	—	—	—	TFP02644	(3)	180	82
	43⅝	1108	80	—	—	—	—	—	—	TFP02645	(3)	201	91
	51⅝	1311	100	—	—	—	—	—	—	TFP02646	(3)	216	98
14" — 150lb 45 elements	33	838	75	—	—	—	—	—	—	TFP02647	(3)	235	107
	43½	1105	100	—	—	—	—	—	—	TFP02648	(3)	262	119
	51½	1308	125	—	—	—	—	—	—	TFP02649	(5)	282	128

NOTE: Flanges 8" and larger are 20 watts/in² (3.1 watts/cm²)

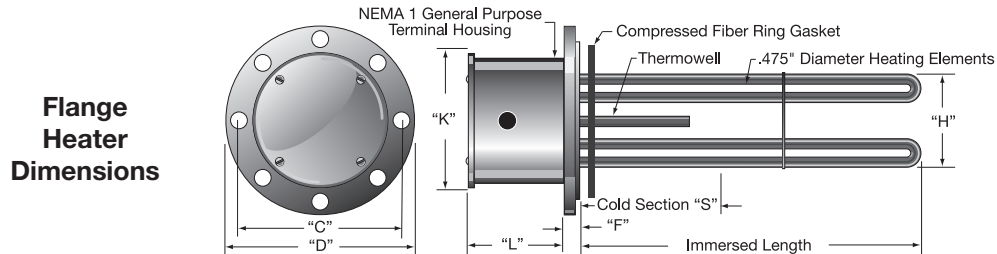

Flange size in	Flange Mounting		Flange Thickness "F"		Mounting Bolt Circle "C"		Flange Diameter "D"		Cold Section "S"		Bundle Diameter "H"		NEMA 1 Housing		Number of Elements			
	Hole Size in	No.	in	mm	in	mm	in	mm	in	mm	in	mm	"K" in	"L" in	Std.	Max.		
3	3/4	4	15/16	24	6	152	7-1/2	191	4	102	2-3/4	70	4-5/8	117	2-5/8	67	3	6
4	3/4	8	15/16	24	7-1/2	191	9	229	4	102	3-7/8	98	6	152	4	102	6	6
5	7/8	8	15/16	24	8-1/2	216	10	254	4	102	5	127	7	178	4	102	6	9
6	7/8	8	1	25	9-1/2	241	11	279	4	102	6	152	8	203	6	152	12	15
8	7/8	8	1-1/8	29	11-3/4	298	13-1/2	343	6	152	7-13/16	198	10	254	6	152	18	24
10	1	12	1-3/16	30	14-1/4	362	16	406	6	152	9-3/4	248	11-5/8	295	6	152	27	36
12	1	12	1-1/4	32	17	432	19	483	6	152	11-3/4	298	13-1/2	343	6	152	36	54
14	1-1/8	12	1-3/8	35	18-3/4	476	21	533	6	152	12-3/4	324	15-1/8	384	6	152	45	72

Ordering Information

See Page 11-31 for complete Ordering Information.



Flanged Immersion Heaters

Standard Flanged Immersion Heaters

48 watts/in² (7.4 watts/cm²) — Typical Applications: Process Water

* 150-lb Raised Face Forged Carbon Steel Flange * Incoloy® 800 Sheath Heating Elements

ANSI Flange Size	Immersed Length		KW	Part Number								Approximate Net Weight	
	in	mm		240V-1Ph	Circuits	240V-3Ph	Circuits	480V-1Ph	Circuits	480V-3Ph	Circuits	lbs	kgs
3" — 150lb 3 elements	13½	343	4.5	TFP02650	(1)	TFP02651	(1)	TFP02652	(1)	TFP02653	(1)	15	7
	18	457	6	TFP02654	(1)	TFP02655	(1)	TFP02656	(1)	TFP02657	(1)	16	7
	20½	521	7.5	TFP02658	(1)	TFP02659	(1)	TFP02660	(1)	TFP02661	(1)	16	7
	25½	648	9	TFP02662	(1)	TFP02663	(1)	TFP02664	(1)	TFP02665	(1)	17	8
	33	838	12	—	—	TFP02666	(1)	TFP02667	(1)	TFP02668	(1)	18	8
	40½	1029	15	—	—	TFP02669	(1)	TFP02670	(1)	TFP02671	(1)	19	9
	48	1219	18	—	—	TFP02672	(1)	TFP02673	(1)	TFP02674	(1)	21	10
4" — 150lb 6 elements	13½	343	9	TFP02675	(1)	TFP02676	(1)	TFP02677	(1)	TFP02678	(1)	26	12
	18	457	12	TFP02679	(2)	TFP02680	(1)	TFP02681	(1)	TFP02682	(1)	28	13
	20½	521	15	TFP02683	(2)	TFP02684	(1)	TFP02685	(1)	TFP02686	(1)	29	13
	25½	648	18	TFP02687	(2)	TFP02688	(1)	TFP02689	(1)	TFP02690	(1)	30	14
	33	838	24	TFP02691	(2)	TFP02692	(2)	TFP02693	(2)	TFP02694	(1)	33	15
	40½	1029	30	—	—	TFP02695	(2)	TFP02696	(2)	TFP02697	(1)	35	16
	48	1219	36	—	—	TFP02698	(2)	TFP02699	(2)	TFP02700	(1)	38	17
5" — 150lb 6 elements	13½	343	9	TFP02701	(1)	TFP02702	(1)	TFP02703	(1)	TFP02704	(1)	30	14
	18	457	12	TFP02705	(2)	TFP02706	(1)	TFP02707	(1)	TFP02708	(1)	32	15
	20½	521	15	TFP02709	(2)	TFP02710	(1)	TFP02711	(1)	TFP02712	(1)	33	15
	25½	648	18	TFP02713	(2)	TFP02714	(1)	TFP02715	(1)	TFP02716	(1)	34	15
	33	838	24	TFP02717	(2)	TFP02718	(2)	TFP02719	(2)	TFP02720	(1)	37	17
	40½	1029	30	—	—	TFP02721	(2)	TFP02722	(2)	TFP02723	(1)	39	18
	48	1219	36	—	—	TFP02724	(2)	TFP02725	(2)	TFP02726	(1)	42	19
5" — 150lb 9 elements	13½	343	14	TFP02727	(3)	TFP02728	(1)	TFP02729	(1)	TFP02730	(1)	33	15
	18	457	18	TFP02731	(3)	TFP02732	(1)	TFP02733	(1)	TFP02734	(1)	35	16
	20½	521	23	TFP02735	(3)	TFP02736	(3)	TFP02737	(1)	TFP02738	(1)	36	16
	25½	648	27	TFP02739	(3)	TFP02740	(3)	TFP02741	(3)	TFP02742	(1)	39	18
	33	838	36	—	—	TFP02743	(3)	TFP02744	(3)	TFP02745	(1)	43	20
	40½	1029	45	—	—	TFP02746	(3)	TFP02747	(3)	TFP02748	(3)	46	21
	48	1219	54	—	—	TFP02749	(3)	TFP02750	(3)	TFP02751	(3)	50	23
6" — 150lb 12 elements	13½	340	18	TFP02752	(2)	TFP02753	(1)	TFP02754	(1)	TFP02755	(1)	43	20
	17½	454	24	TFP02756	(2)	TFP02757	(2)	TFP02758	(2)	TFP02759	(1)	46	21
	20½	518	30	TFP02760	(3)	TFP02761	(2)	TFP02762	(2)	TFP02763	(1)	48	22
	25½	645	36	TFP02764	(3)	TFP02765	(2)	TFP02766	(2)	TFP02767	(1)	51	23
	32½	835	48	—	—	TFP02768	(4)	TFP02769	(3)	TFP02770	(2)	56	25
	40½	1026	60	—	—	TFP02771	(4)	TFP02772	(3)	TFP02773	(2)	61	28
	47½	1216	72	—	—	TFP02774	(4)	—	—	TFP02775	(2)	66	30
6" — 150lb 15 elements	13½	340	23	TFP02776	(3)	TFP02777	(5)	TFP02778	(1)	TFP02779	(1)	45	20
	17½	454	30	TFP02780	(3)	TFP02781	(5)	TFP02782	(3)	TFP02783	(1)	49	22
	20½	518	38	TFP02784	(5)	TFP02785	(5)	TFP02786	(3)	TFP02787	(1)	51	23
	25½	645	45	TFP02788	(5)	TFP02789	(5)	TFP02790	(3)	TFP02791	(5)	55	25
	32½	835	60	—	—	TFP02792	(5)	TFP02793	(3)	TFP02794	(5)	62	28
	40½	1026	75	—	—	TFP02795	(5)	TFP02796	(5)	TFP02797	(5)	68	31
	47½	1216	90	—	—	TFP02798	(5)	—	—	TFP02799	(5)	75	34
8" — 150lb 18 elements	25¼	654	50	—	—	TFP02800	(3)	TFP02801	(3)	TFP02802	(2)	81	37
	35¼	908	75	—	—	TFP02803	(6)	—	—	TFP02804	(2)	91	41
	44¼	1124	100	—	—	TFP02805	(6)	—	—	TFP02806	(3)	100	45
	54¼	1378	125	—	—	TFP02807	(6)	—	—	TFP02808	(6)	110	50
	63¼	1607	150	—	—	—	—	—	—	TFP02809	(6)	119	54
	72¼	1848	175	—	—	—	—	—	—	TFP02810	(6)	129	59
	82¼	2089	200	—	—	—	—	—	—	TFP02811	(6)	139	63
8" — 150lb 24 elements	25¼	654	67	—	—	—	—	TFP02813	(3)	TFP02814	(2)	90	41
	35¼	908	100	—	—	TFP02812	(4)	—	—	TFP02816	(4)	104	47
	44¼	1124	133	—	—	TFP02815	(8)	—	—	TFP02818	(4)	115	52
	54¼	1378	167	—	—	TFP02819	(8)	—	—	TFP02820	(8)	129	59
	63¼	1607	200	—	—	—	—	—	—	TFP02821	(8)	141	64
	72¼	1848	233	—	—	—	—	—	—	TFP02822	(8)	154	70
	82¼	2089	267	—	—	—	—	—	—	TFP02823	(8)	167	76

CONTINUED

Standard Flanged Immersion Heaters

Continued from previous page...

48 watts/in² (7.4 watts/cm²) — Typical Applications: Process Water

* 150-lb Raised Face Forged Carbon Steel Flange * Incoloy® 800 Sheath Heating Elements

ANSI Flange Size	Immersed Length		KW	Part Number								Approximate Net Weight	
	in	mm		240V-1Ph Circuits	240V-3Ph Circuits	480V-1Ph Circuits	480V-3Ph Circuits	lbs	kgs				
10" — 150lb 27 elements	54 ³ / ₄	1391	190	—	—	—	TFP02824	(9)	160	73			
	63 ³ / ₄	1619	225	—	—	—	TFP02825	(9)	173	78			
	73 ¹ / ₄	1861	262	—	—	—	TFP02826	(9)	188	85			
12" — 150lb 36 elements	54 ³ / ₈	1387	250	—	—	—	TFP02827	(6)	224	102			
	63 ³ / ₈	1616	300	—	—	—	TFP02828	(12)	242	110			
	73 ³ / ₈	1857	350	—	—	—	TFP02829	(12)	262	119			
14" — 150lb 45 elements	54 ¹ / ₂	1384	315	—	—	—	TFP02830	(15)	290	132			
	63 ¹ / ₂	1603	375	—	—	—	TFP02831	(15)	312	142			

Flange Heater Dimensions

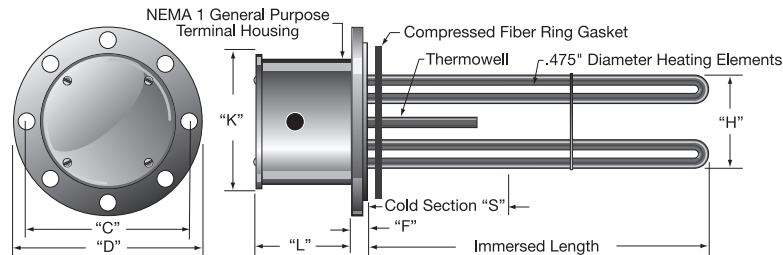

Flange size in	Flange Mounting		Flange Thickness "F"		Mounting Bolt Circle "C"		Flange Diameter "D"		Cold Section "S"		Bundle Diameter "H"		NEMA 1 Housing		Number of Elements				
	Hole Size in	No.	in	mm	in	mm	in	mm	in	mm	in	mm	"K"	"L"	Std.	Max.			
3	3/4	19	4	15/16	24	6	152	7-1/2	191	4	102	2-3/4	70	4-5/8	117	2-5/8	67	3	6
4	3/4	19	8	15/16	24	7-1/2	191	9	229	4	102	3-7/8	98	6	152	4	102	6	6
5	7/8	22	8	15/16	24	8-1/2	216	10	254	4	102	5	127	7	178	4	102	6	9
6	7/8	22	8	1	25	9-1/2	241	11	279	4	102	6	152	8	203	6	152	12	15
8	7/8	22	8	1-1/8	29	11-3/4	298	13-1/2	343	6	152	7-13/16	198	10	254	6	152	18	24
10	1	25	12	1-3/16	30	14-1/4	362	16	406	6	152	9-3/4	248	11-5/8	295	6	152	27	36
12	1	25	12	1-1/4	32	17	432	19	483	6	152	11-3/4	298	13-1/2	343	6	152	36	54
14	1-1/8	29	12	1-3/8	35	18-3/4	476	21	533	6	152	12-3/4	324	15-1/8	384	6	152	45	72

Ordering Information

See Page 11-31 for complete Ordering Information.

Standard Flanged Immersion Heaters

60 watts/in² (9.3 watts/cm²) — Typical Applications: Deionized Water

* 150-lb Raised Face 316 Stainless Steel Flange * 316 Stainless Steel Sheath Heating Elements

ANSI Flange Size	Immersed Length		KW	Part Number								Approximate Net Weight	
	in	mm		240V-1Ph	Circuits	240V-3Ph	Circuits	480V-1Ph	Circuits	480V-3Ph	Circuits	lbs	kgs
4" — 150lb 6 elements	16	406	12	TFP02960	(2)	TFP02961	(1)	TFP02962	(1)	TFP02963	(1)	27	12
	22	559	18	TFP02964	(2)	TFP02965	(1)	TFP02966	(1)	TFP02967	(1)	29	13
	27½	699	24	TFP02968	(2)	TFP02969	(2)	TFP02970	(1)	TFP02971	(1)	31	14
	33	838	30	—	—	TFP02972	(2)	TFP02973	(2)	TFP02974	(1)	32	15
	38½	978	36	—	—	TFP02975	(2)	TFP02976	(2)	TFP02977	(1)	35	16
	51½	1308	50	—	—	—	—	—	—	TFP02978	(2)	39	18
61	1549	60	—	—	—	—	—	—	TFP02979	(2)	42	19	
6" — 150lb 12 elements	15¼	400	24	TFP02980	(3)	TFP02981	(2)	TFP02982	(2)	TFP02983	(1)	45	20
	21¼	552	36	TFP02984	(3)	TFP02985	(2)	TFP02986	(2)	TFP02987	(1)	49	22
	27¼	692	48	—	—	TFP02988	(4)	TFP02989	(3)	TFP02990	(2)	52	24
	32¼	832	60	—	—	TFP02991	(4)	TFP02992	(3)	TFP02993	(2)	56	25
	38¼	972	72	—	—	TFP02994	(4)	—	—	TFP02995	(2)	60	27
	51¼	1302	100	—	—	—	—	—	—	TFP02996	(4)	69	31
60¼	1543	120	—	—	—	—	—	—	TFP02997	(4)	75	34	
6" — 150lb 15 elements	15¼	400	30	TFP02998	(3)	TFP02999	(5)	TFP03000	(3)	TFP03001	(1)	47	21
	21¼	552	45	TFP03002	(5)	TFP03003	(5)	TFP03004	(3)	TFP03005	(5)	52	24
	27¼	692	60	—	—	TFP03006	(5)	TFP03007	(3)	TFP03008	(5)	57	26
	32¼	832	75	—	—	TFP03009	(5)	TFP03010	(5)	TFP03011	(5)	62	28
	38¼	972	90	—	—	TFP03012	(5)	—	—	TFP03013	(5)	66	30
	51¼	1302	125	—	—	—	—	—	—	TFP03014	(5)	77	35
60¼	1543	150	—	—	—	—	—	—	TFP03015	(5)	86	39	

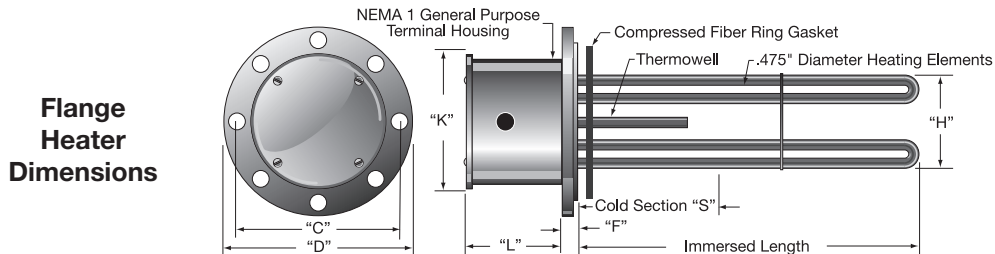

Flange size in	Flange Mounting		Flange Thickness "F" in mm	Mounting Bolt Circle "C" in mm	Flange Diameter "D" in mm	Cold Section "S" in mm	Bundle Diameter "H" in mm	NEMA 1 Housing		Number of Elements	
	Hole Size in mm	No.						"K" in mm	"L" in mm	Std.	Max.
3	3/4	19	4	15/16 24	6 152	7-1/2 191	2-3/4 70	4-5/8 117	2-5/8 67	3	6
4	3/4	19	8	15/16 24	7-1/2 191	9 229	3-7/8 98	6 152	4 102	6	6
5	7/8	22	8	15/16 24	8-1/2 216	10 254	5 127	7 178	4 102	6	9
6	7/8	22	8	1 25	9-1/2 241	11 279	6 152	8 203	6 152	12	15
8	7/8	22	8	1-1/8 29	11-3/4 298	13-1/2 343	6 152	7-13/16 198	10 254	6 152	18 24
10	1	25	12	1-3/16 30	14-1/4 362	16 406	6 152	9-3/4 248	11-5/8 295	6 152	27 36
12	1	25	12	1-1/4 32	17 432	19 483	6 152	11-3/4 298	13-1/2 343	6 152	36 54
14	1-1/8	29	12	1-3/8 35	18-3/4 476	21 533	6 152	12-3/4 324	15-1/8 384	6 152	45 72



Standard Flanged Immersion Heaters

60 watts/in² (9.3 watts/cm²) — Typical Applications: Clean Water

* 150-lb Raised Face Forged Carbon Steel Flange

* Copper Sheath Heating Elements

ANSI Flange Size	Immersed Length		KW	Part Number								Approximate Net Weight	
	in	mm		240V-1Ph	Circuits	240V-3Ph	Circuits	480V-1Ph	Circuits	480V-3Ph	Circuits	lbs	kgs
3" — 150lb 3 elements	15½	394	6	TFP02832	(1)	TFP02833	(1)	TFP02834	(1)	TFP02835	(1)	15	7
	21½	546	9	TFP02836	(1)	TFP02837	(1)	TFP02838	(1)	TFP02839	(1)	16	7
	27	686	12	—	—	TFP02840	(1)	TFP02841	(1)	TFP02842	(1)	17	8
	32½	826	15	—	—	TFP02843	(1)	TFP02844	(1)	TFP02845	(1)	18	8
	38	965	18	—	—	TFP02846	(1)	TFP02847	(1)	TFP02848	(1)	19	9
	51	1295	25	—	—	—	—	TFP02849	(1)	TFP02850	(1)	21	10
	60½	1537	30	—	—	—	—	TFP02851	(1)	TFP02852	(1)	23	10
4" — 150lb 6 elements	15½	394	12	TFP02853	(2)	TFP02854	(1)	TFP02855	(1)	TFP02856	(1)	27	12
	21½	546	18	TFP02857	(2)	TFP02858	(1)	TFP02859	(1)	TFP02860	(1)	29	13
	27	686	24	TFP02861	(2)	TFP02862	(2)	TFP02863	(2)	TFP02864	(1)	31	14
	32½	826	30	—	—	TFP02865	(2)	TFP02866	(2)	TFP02867	(1)	33	15
	38	965	36	—	—	TFP02868	(2)	TFP02869	(2)	TFP02870	(1)	35	16
	51	1295	50	—	—	—	—	—	—	TFP02871	(2)	39	18
	60½	1537	60	—	—	—	—	—	—	TFP02872	(2)	42	19
5" — 150lb 6 elements	15½	394	12	TFP02873	(2)	TFP02874	(1)	TFP02875	(1)	TFP02876	(1)	31	14
	21½	546	18	TFP02877	(2)	TFP02878	(1)	TFP02879	(1)	TFP02880	(1)	33	15
	27	686	24	TFP02881	(2)	TFP02882	(2)	TFP02883	(2)	TFP02884	(1)	35	16
	32½	826	30	—	—	TFP02885	(2)	TFP02886	(2)	TFP02887	(1)	37	17
	38	965	36	—	—	TFP02888	(2)	TFP02889	(2)	TFP02890	(1)	39	18
	51	1295	50	—	—	—	—	—	—	TFP02891	(2)	43	20
	60½	1537	60	—	—	—	—	—	—	TFP02892	(2)	46	21
5" — 150lb 9 elements	15½	394	18	TFP02893	(3)	TFP02894	(1)	TFP02895	(1)	TFP02896	(1)	34	15
	21½	546	27	TFP02897	(3)	TFP02898	(3)	TFP02899	(3)	TFP02900	(3)	37	17
	27	686	36	—	—	TFP02901	(3)	TFP02902	(3)	TFP02903	(3)	40	18
	32½	826	45	—	—	TFP02904	(3)	TFP02905	(3)	TFP02906	(3)	42	19
	38	965	54	—	—	TFP02907	(3)	TFP02908	(3)	TFP02909	(3)	45	20
	51	1295	75	—	—	—	—	—	—	TFP02910	(3)	52	24
	60½	1537	90	—	—	—	—	—	—	TFP02911	(3)	57	26
6" — 150lb 12 elements	15½	391	24	TFP02912	(2)	TFP02913	(2)	TFP02914	(2)	TFP02915	(1)	44	20
	21½	543	36	TFP02916	(3)	TFP02917	(2)	TFP02918	(2)	TFP02919	(1)	48	22
	26½	683	48	—	—	TFP02920	(4)	TFP02921	(4)	TFP02922	(2)	52	24
	32½	822	60	—	—	TFP02923	(4)	TFP02924	(4)	TFP02925	(2)	56	25
	37½	962	72	—	—	TFP02926	(4)	—	—	TFP02927	(2)	60	27
	50½	1292	100	—	—	—	—	—	—	TFP02928	(4)	68	31
	60½	1534	120	—	—	—	—	—	—	TFP02929	(4)	75	34
6" — 150lb 15 elements	15½	391	30	TFP02930	(3)	TFP02931	(5)	TFP02932	(3)	TFP02933	(1)	47	21
	21½	543	45	TFP02934	(5)	TFP02935	(5)	TFP02936	(3)	TFP02937	(5)	52	24
	26½	683	60	—	—	TFP02938	(5)	TFP02939	(3)	TFP02940	(5)	57	26
	32½	822	75	—	—	TFP02941	(5)	TFP02942	(5)	TFP02943	(5)	61	28
	37½	962	90	—	—	TFP02944	(5)	—	—	TFP02945	(5)	66	30
	50½	1292	125	—	—	—	—	—	—	TFP02946	(5)	77	35
	60½	1534	150	—	—	—	—	—	—	TFP02947	(5)	85	39
8" — 150lb 18 elements	21¼	553	50	—	—	TFP02948	(3)	TFP02949	(3)	TFP02950	(2)	77	35
	29¼	756	75	—	—	TFP02951	(6)	—	—	TFP02952	(2)	85	39
	37¼	946	100	—	—	TFP02953	(6)	—	—	TFP02954	(3)	93	42
	45¼	1149	125	—	—	TFP02955	(6)	—	—	TFP02956	(6)	101	46
	52¼	1340	150	—	—	—	—	—	—	TFP02957	(6)	109	49
	60¼	1543	175	—	—	—	—	—	—	TFP02958	(6)	117	53
	68¼	1734	200	—	—	—	—	—	—	TFP02959	(6)	125	57

Ordering Information

See Page 11-31 for complete
Ordering Information.

Standard Flanged Immersion Heaters

60 watts/in² (9.3 watts/cm²) — Typical Applications: Deionized Water

* 150-lb Raised Face 316 Stainless Steel Flange * 316 Stainless Steel Sheath Heating Elements

ANSI Flange Size	Immersed Length		KW	Part Number								Approximate Net Weight	
	in	mm		240V-1Ph Circuits	240V-3Ph Circuits	480V-1Ph Circuits	480V-3Ph Circuits	lbs	kgs				
4" — 150lb 6 elements	16	406	12	TFP02960	2	TFP02961	1	TFP02962	1	TFP02963	1	27	12
	22	559	18	TFP02964	2	TFP02965	1	TFP02966	1	TFP02967	1	29	13
	27½	699	24	TFP02968	2	TFP02969	2	TFP02970	1	TFP02971	1	31	14
	33	838	30	—	—	TFP02972	2	TFP02973	2	TFP02974	1	32	15
	38½	978	36	—	—	TFP02975	2	TFP02976	2	TFP02977	1	35	16
	51½	1308	50	—	—	—	—	—	—	TFP02978	2	39	18
	61	1549	60	—	—	—	—	—	—	TFP02979	2	42	19
6" — 150lb 12 elements	15¾	400	24	TFP02980	3	TFP02981	2	TFP02982	2	TFP02983	1	45	20
	21¾	552	36	TFP02984	3	TFP02985	2	TFP02986	2	TFP02987	1	49	22
	27¾	692	48	—	—	TFP02988	4	TFP02989	3	TFP02990	2	52	24
	32¾	832	60	—	—	TFP02991	4	TFP02992	3	TFP02993	2	56	25
	38¾	972	72	—	—	TFP02994	4	—	—	TFP02995	2	60	27
	51¼	1302	100	—	—	—	—	—	—	TFP02996	4	69	31
	60¾	1543	120	—	—	—	—	—	—	TFP02997	4	75	34
6" — 150lb 15 elements	15¾	400	30	TFP02998	3	TFP02999	5	TFP03000	3	TFP03001	1	47	21
	21¾	552	45	TFP03002	5	TFP03003	5	TFP03004	3	TFP03005	5	52	24
	27¾	692	60	—	—	TFP03006	5	TFP03007	3	TFP03008	5	57	26
	32¾	832	75	—	—	TFP03009	5	TFP03010	5	TFP03011	5	62	28
	38¾	972	90	—	—	TFP03012	5	—	—	TFP03013	5	66	30
	51¼	1302	125	—	—	—	—	—	—	TFP03014	5	77	35
	60¾	1543	150	—	—	—	—	—	—	TFP03015	5	86	39

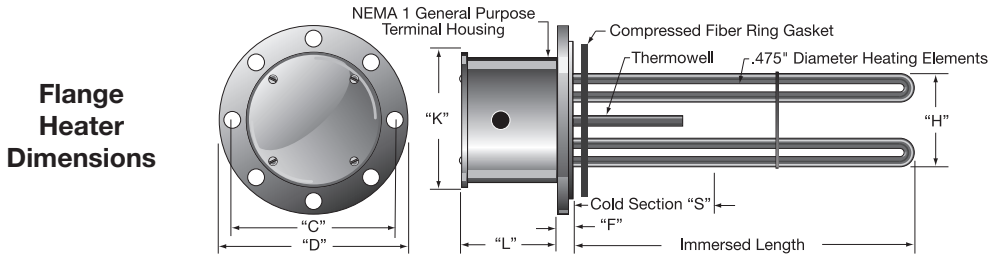

Flange size in	Flange Mounting		Flange Thickness "F" in mm	Mounting Bolt Circle "C" in mm	Flange Diameter "D" in mm	Cold Section "S" in mm	Bundle Diameter "H" in mm	NEMA 1 Housing		Number of Elements Std. Max.									
	Hole Size in	No.						"K" in mm	"L" in mm										
3	3/4	19	4	15/16	24	6	152	7-1/2	191	4	102	2-3/4	70	4-5/8	117	2-5/8	67	3	6
4	3/4	19	8	15/16	24	7-1/2	191	9	229	4	102	3-7/8	98	6	152	4	102	6	6
5	7/8	22	8	15/16	24	8-1/2	216	10	254	4	102	5	127	7	178	4	102	6	9
6	7/8	22	8	1	25	9-1/2	241	11	279	4	102	6	152	8	203	6	152	12	15
8	7/8	22	8	1-1/8	29	11-3/4	298	13-1/2	343	6	152	7-13/16	198	10	254	6	152	18	24

Ordering Information

See Page 11-31 for complete Ordering Information.

Custom Designed Flanged Heater for Sanitary Process Solutions

Sanitary fittings are commonly used in the commercial food, dairy and soft drink processing industries. Compared to common pipe flange connections, the sanitary pipe connections' crevice-free interiors provide quicker access for easier cleaning.

Fittings and pipe made from 304 Stainless Steel is suitable for most food industry applications. Type 316L, which is more corrosion resistant, is commonly used in the pharmaceutical and chemical industries.



Design Features

- * 304 SS flange (end cap) suitable for most food applications
- * 316L SS flange (end cap) used in chemical industries
- * 304 SS, 316 SS and Incoloy heating elements
- * Element hairpin bends are spanked in specially designed dies to re-compact the MgO insulating powder
- * Silicone resin seal of elements standard
- * NEMA 1 electrical enclosure standard, NEMA 4/7 optional

Heater Construction

This passivated heater assembly consists of tubular electric heating elements welded into a 6" sanitary end cap fitting which would then be clamped to another fitting in the system. This particular sanitary process uses manufacturer Alfa Laval's fittings.



Connection Components

A typical sanitary type connection is made by joining two ferrules together with a clamp and a gasket. The ferrule is the end of the fitting or pipe that has a lip with a gasket groove making it half of a finished connection.

The heater in the picture at right is shown clamped to the Butt-Weld fitting shown on the left.

Ordering Information

Catalog Heaters

Sanitary Flanged Immersion Heaters are custom manufactured to meet the requirements of specific applications.

Custom Engineered/Manufactured Heaters

TEMPCO will design and manufacture a Sanitary Flanged Immersion Heater to meet your requirements. **Standard lead time is 4 weeks.**

Please Specify the following:

- | | |
|---|---|
| <input type="checkbox"/> Wattage, Voltage and Phase | <input type="checkbox"/> Element Immersion Length |
| <input type="checkbox"/> Flange (End Cap) Size and Material | <input type="checkbox"/> Surface Treatments |
| <input type="checkbox"/> Element Sheath Material | <input type="checkbox"/> Electrical Enclosure Type |
| <input type="checkbox"/> Element Watt Density | <input type="checkbox"/> Other Type Sanitary Fittings |

⚠ WARNING: Cancer and Reproductive Harm - www.P65Warnings.ca.gov.

Circulation Heaters

**Self-contained heating units designed for optimum operating efficiency and performance—
Providing trouble-free service and application flexibility!**

All of the heat generated by the elements is immediately transferred to the medium being processed with minimal losses.

Standard and optional features include...

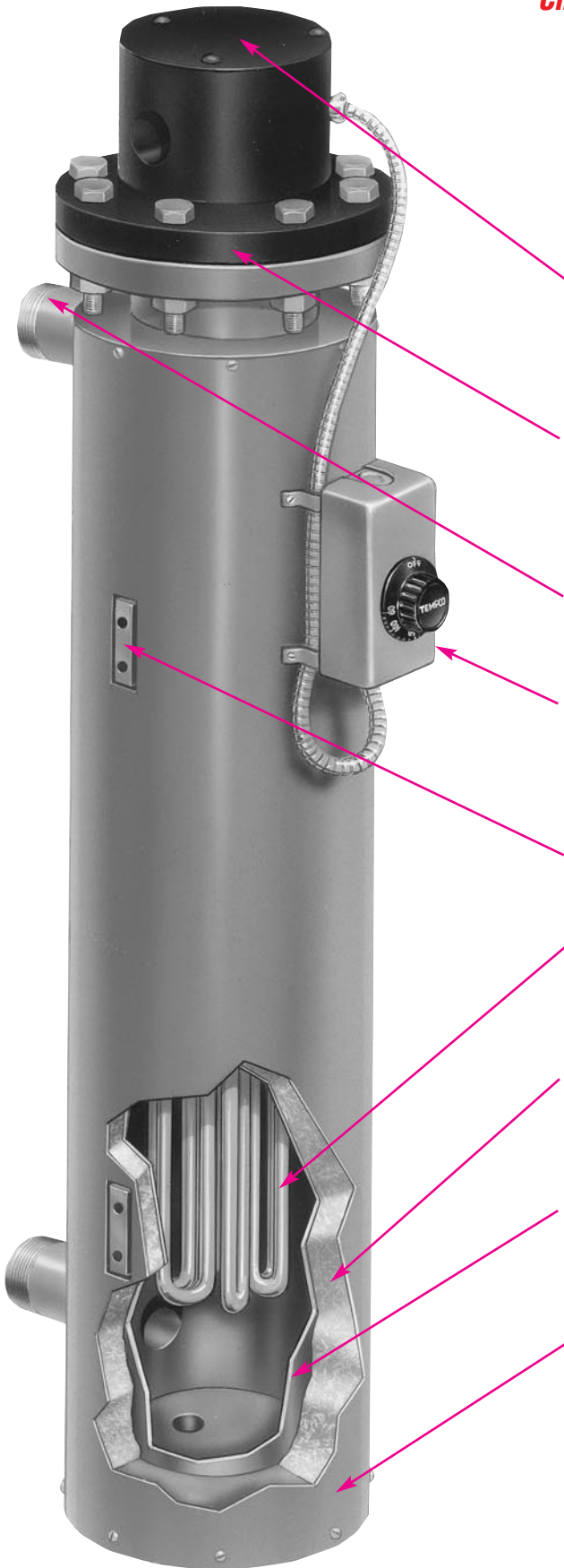

A General purpose (NEMA 1) terminal housing is standard. Moisture proof (NEMA 4) and/or explosion resistant (NEMA 7) housings are optional. A set of installation and maintenance instructions along with a wiring diagram can be found inside the terminal housing of each unit.

B Heating source—1-1/4" and 2-1/2" Screw Plug Heaters are used on smaller units. 3" to 14" size heaters use Flanged Immersion Heaters. The flanges are made from forged steel rated for 150 lbs with raised face. Supplied with threaded eyebolts for ease of handling and installation. Optional stainless steel flanges or 300 lb ratings available.

C Inlet-outlet connections are NPT pipe threads for 3" to 8" Circulation Heaters (flanges are optional). Standard inlet-outlet connections on 10" and larger units are 150 lb. rated flanges.

D Optional feature double-pole non-indicating bulb and capillary type thermostat can be located in the terminal box (standard) or attached to the insulation jacket as pictured. Solid state temperature controllers and indicating thermostats are available. Over-temperature protection can be provided by attaching a thermocouple to one of the elements.

E Threaded mounting lugs to support the unit are welded to the steel vessel. Custom supports can be designed to fit your structure.

F Wide selection of heating element sheath materials for maximum corrosion resistance to the medium being processed. On smaller circulation units with screw plug heaters, the element diameter is .315" or .475". On larger units with flanged heaters, the element diameter is .475".

G The vessel is surrounded with 1" thick insulation rated to 750°F (399°C) to minimize heat loss. Additional insulation or a high temperature ceramic fiber insulation is optional. Vessels can also be supplied uninsulated.

H Vessel material is SA53B or SA106B steel. Good for up to 750°F (399°C) operating temperature. For drainage and cleaning purposes, a drain plug is located in the base of the tank. Optional: Stainless steel vessel.

I Outer stainless steel sheet metal jacket protects the insulation from the environment and keeps it dry. Optional: Stainless steel outer jacket with a weather-tight seal.



Note: Branch Circuit Wiring: Flange heater elements are wired into branch circuits having a maximum current of 48 Amps. The number of circuits is listed next to the heater's voltage and phase in the standard sizes and ratings chart. For different circuit wiring configurations, consult Tempco.

Checklist — Selecting the Proper Circulation Heater

Determine a Safe and Efficient Element Watt Density

Element Watt Density is the wattage dissipated per square inch of the element sheath surface and is calculated with the following formula:

$$\text{Watt Density} = \frac{\text{element wattage}}{\pi \times \text{element dia.} \times \text{element heated length}}$$

For a particular application, element watt density will govern element sheath temperature. Factors to consider when choosing a suitable watt density are:

1. Many materials are heat sensitive and can decompose or be damaged if the element is running too hot.
2. Air and other gases that are poor conductors of heat require watt densities matched to the velocity of the gas flow to prevent element overheating.
3. Mineral deposits when heating hard water and cleaning solutions can build up on the element sheath, acting as a heat insulator and raising the internal element temperature. If these deposits cannot be periodically removed, use a lower watt density element to increase heater life expectancy.

Select the Element Sheath Material

Sheath Material Selection

CORROSION. In addition to selecting a sheath material that is compatible with the heated medium, other factors that affect corrosion need to be considered:

1. **The temperature of the corrodent** — As temperature increases the degree of corrosion increases. Also remember that usually the element temperature is higher than the material it is heating.
2. **The degree of aeration to which a corrodent is exposed** — Stagnant conditions can deprive the stainless steels of oxygen, which is required to maintain their corrosion resistant surface.
3. **Velocity of the corrodent** — Increased velocity can increase the corrosion rate.



Note: See pages 16-12 through 16-20 for the recommended sheath materials for many immersion heating applications. If you are purchasing the material you are heating, check with the supplier for their recommendations.

Standard Element Sheath Materials

Incoloy® 800 — A Nickel (30-35%), Chromium (19-23%), Iron alloy. The high nickel content of this alloy contributes to its resistance to scaling and corrosion. Used in air heating (also see Incoloy® 840) and immersion heating of potable water and other liquids that are not corrosive to an Incoloy® 800 sheath.

Low Carbon Steel — Applications include fluid heat transfer media, tar, high to low viscosity petroleum oils, asphalt, wax, molten salt, and other solutions not corrosive to a steel sheath.

316 Stainless Steel — A Chromium (16-18%), Nickel (11-14%), Iron Alloy with Molybdenum (2-3%) added to improve corrosion resistance in certain environments, especially those that would tend to cause pitting due to the presence of chlorides. Applications include deionized water.

Copper — Mainly used in clean water heating for washrooms, showers, rinse tanks and freeze protection of storage tanks.

Optional Element Sheath Materials

304 Stainless Steel — A Chromium (18-20%), Nickel (8-11%), Iron Alloy used in the food industry, sterilizing solutions, air heating and many organic and inorganic chemicals.

321 Stainless Steel — A Chromium (17-20%), Nickel (9-13%), Iron Alloy modified with the addition of titanium to prevent carbide precipitation and the resulting intergranular corrosion that can take place in certain mediums when operating in the 800-1200°F (427-649°C) temperature range.

Incoloy® 840 — A Nickel (18-20%), Chromium (18-22%), Iron alloy. Incoloy 840 has about 10% less nickel than Incoloy 800. Used in many air heating applications where it has exhibited superior oxidation resistance at less cost than Incoloy 800.

Incoloy® 825 — A Nickel (38-46%), Chromium (19.5-23.5%), Molybdenum (2-3%) Iron alloy. Consult Tempco for more information.

Surface Treatments for Stainless Steel and Incoloy® Elements and other Wetted Parts to Improve Corrosion Resistance

Flanged Immersion Heater surfaces in contact with the material being heated can be passivated or electro-polished to improve their resistance to corrosion.

Passivation removes surface contamination, usually iron, so that the optimum corrosion resistance of the stainless steel is maintained. Surface contamination would come from the small amount of steel that may be worn off a tool during the manufacturing process. Passivating is accomplished by dipping the heater in a warm solution of nitric acid.

Electro-Polishing is an electrochemical process that removes surface imperfections and contaminants, enhancing the corrosion resisting ability of the stainless steels. The resultant surface is clean, smooth and bright. Many medical and food applications require this finish.



Checklist — Selecting the Proper Circulation Heater, *continued*

☑ Standard Terminal Housings

Terminal Housings

Tempco Circulation Heaters are supplied with a **General Purpose Housing** (NEMA 1) as standard unless otherwise specified.

Additional housing types include:

Moisture Resistant (NEMA 4)

Explosion Resistant (NEMA 7)

Moisture/Explosion Resistant (NEMA 4/7).

Descriptions and dimensions of housings for circulation heaters with screw plugs can be found on page 11-4, and for flange heaters on pages 11-26 and 11-27. If none of these housings meet the size, construction or other criteria of your application, consult Tempco with your requirements.



Explosion resistant terminal housings are intended to provide containment of an explosion in the enclosure only. No portion of the heater assembly outside the enclosure is covered under this NEMA rating.

Abnormal use of a heater which results in excessive temperature can create hazardous conditions such as a fire. Never perform any type of service nor remove the housing cover prior to disconnecting all electrical power to the heater.



Optional Terminal Housing Standoff Construction

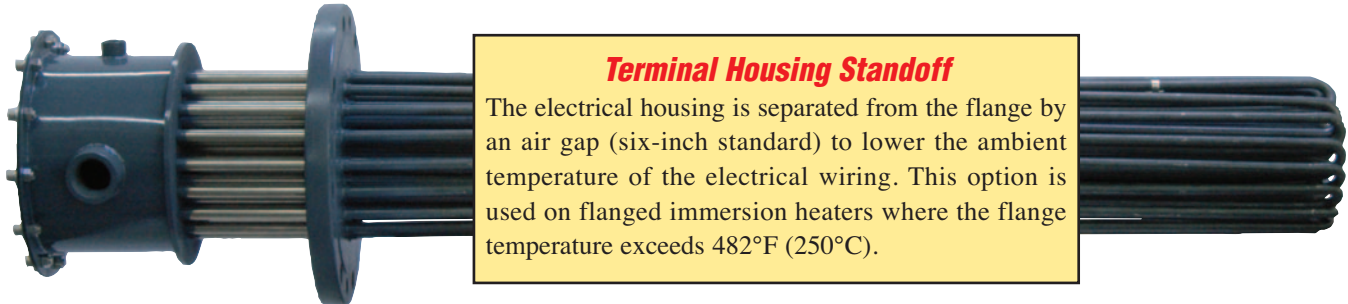

Terminal Housing Standoff

The electrical housing is separated from the flange by an air gap (six-inch standard) to lower the ambient temperature of the electrical wiring. This option is used on flanged immersion heaters where the flange temperature exceeds 482°F (250°C).

Optional Circulation Heater Features

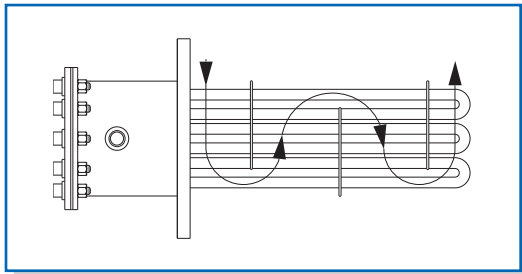

Flow Control Baffles

Used on circulation tank heaters to aid heat transfer by forcing the liquid or gas back and forth across the elements. Baffles can be custom designed and positioned for your application.

Temperature Control

Thermostats

Thermostats are an optional feature on flanged immersion heaters. This type of control operates by expansion and contraction of a liquid in response to temperature change. Liquid contained within the sensing bulb and capillary flexes a diaphragm, causing the opening and closing of a snap action switch. For heating applications the contacts are normally closed and open on temperature rise.

Installation Warnings and Recommendations



1. **Do not use the thermostat as a power switch. Use some other means of disconnecting power to the heater for servicing.**
2. **A Thermostat is not a fail-safe device. Use an approved high temperature limit control and/or pressure limit control for safe operation.**
3. **Avoid kinking or bending the capillary tube too sharply as this will alter the calibration and/or render the thermostat inoperable.**
4. **Excess capillary tube should be coiled neatly in junction box.**
5. **The capillary tube must never touch the thermostat contacts as this will create an electrical short capable of harming personnel and/or equipment.**

Thermocouples

Type J or Type K thermocouples can be supplied for process temperature or over-temperature control. Type J is reliable and accurate for temperatures up to 1000°F (538°C). Type K should be used for higher temperatures.

For measuring process temperatures the thermocouple can be mounted in a thermowell in the center of the element bundle. Note that a location somewhere away from the heater may give a more accurate measurement of process temperature.

For over-temperature protection the thermocouple is usually attached to one of the elements (Figure A) and any unusual rise in element temperature would shut the heater down. This thermocouple may also be mounted in a thermowell (Figure B), which is then attached to one of the heating elements if desired. This protects the thermocouple from the solution being heated and allows you to replace it without removing the heater, but does increase its response time.

Temperature and over-temperature controls for using the signal generated by thermocouples and how to select the best control for your application can be found in Section 13.

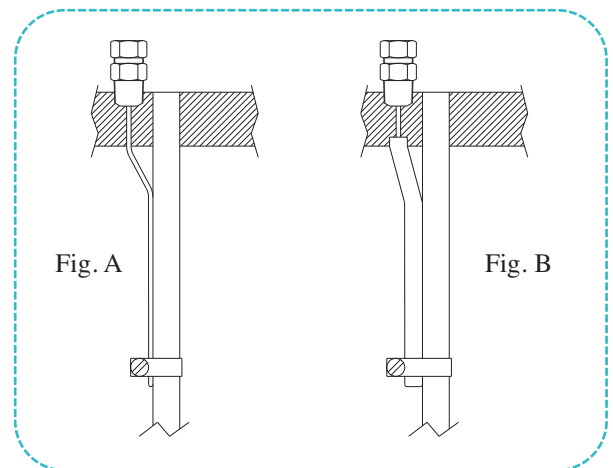

Series CHX-100, CHX-200 and CHX-300 Circulation Heaters — See Pages 3-12 through 3-17

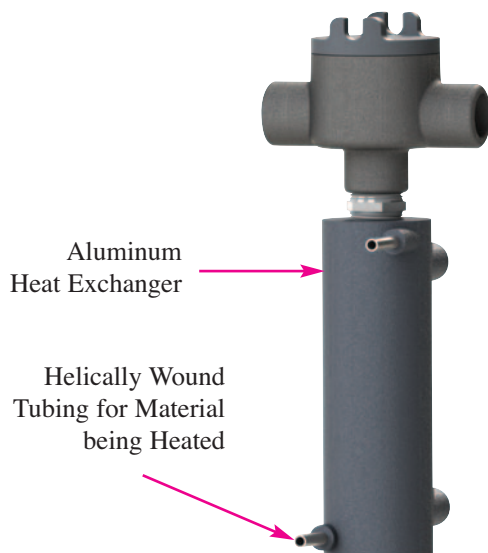

Construction

Series CHX circulation heaters are compact lightweight units used for heating gases or liquids. The material being heated is pumped through the coiled seamless 316 SS tubing which has been cast into an aluminum body which acts as the heat exchanger. A replaceable Hi-Density cartridge set into a hole bored into the aluminum is the heat source for the CHX-100, and a tubular heating element is the heat source for the CHX-200 and CHX-300. The material being heated never comes into contact with the heating element.

Circulation Heater Installation Recommendations

Tempco Circulation Heaters will have a long life and provide dependable, trouble-free service if properly installed, operated and maintained as per the following recommendations:

Installation

1. Flange heaters are supplied with two drilled and tapped holes for threaded eye bolts, providing ease of handling during installation and flange removal during maintenance cleaning or heater replacement.
2. Replacement of heater is inevitable. Therefore, provide adequate space for installation, allowing ample room to remove the flange heater for cleaning or replacement.
3. In applications requiring the circulation heater to be fed by an inline pump, install the pump at the inlet end.
4. To maintain the lowest possible temperature at the terminal box, place the outlet at the end opposite to the terminal box. If your process temperature is circulating at 450°F (232°C) or above (at the nozzle closest to the flange), stand-off terminal box construction is recommended.
5. To prevent temperature and/or pressure buildup on closed loop circulation heater systems, adequate and strategically located thermocouples for temperature controllers and pressure relief valves should be installed. Never over-rate pressure relief valves beyond the pressure temperature rating of the flange being used.
6. During the process cycle, flow rate of the medium being heated should never be interrupted or reduced, thus creating an overheating condition. Excess temperature can result in damage to the medium being processed and premature heater failure.
7. Make sure that your circulation heater is equipped with the proper terminal housing for the environment in which the heater is being used. NEMA 1—General purpose, NEMA 4—Moisture resistant, and NEMA 7—Explosion resistant.



Wiring

1. All heater installations must be properly earth grounded to eliminate electric shock hazard. Electrical wiring must be in accordance with Local and/or National Electrical Codes.
2. Circulation heaters are supplied standard with NEMA 1 terminal housings. All power to heaters must be disconnected before removing the terminal housing cover and performing any type of service.
3. Electrical connections on heater terminals must be kept tight. Loose connections will create arcing, over-heating, and eventually will destroy the heater terminal and cause premature heater failure.
4. If the amperage rating of your circulation heater exceeds the amperage capacity of the supplied thermostat, mercury relays or magnetic contactors should be used with the thermostat. See pages 13-92 through 13-96.
5. Over-temperature protection thermocouples require a separate conduit to the control panel for the thermocouple wire.
6. Tempco offers a large selection of Power Control Panels for circulation heaters. See pages 13-56 through 13-63.

Maintenance

1. Never perform any type of service on the unit prior to disconnecting all electrical power and shutting off all intake lines.
2. Remove sludge deposits through the drain plug.
3. Check flange bolts for tightness.
4. Check terminal connections for tightness.
5. Check thermocouple or thermostat bulb for response to temperature changes. If defective, replace immediately.
6. Check for leaks.
7. Depending on operating conditions and medium being processed, the flange or screw plug heater should be periodically removed for physical inspection and cleaning of the element bundle.

Vertical Mounting—Liquids

With terminal housing up and inlet pipe on the bottom, the heating elements will be immersed at all times to prevent premature failure.



Horizontal Mounting—Liquids and Gases

Always mount heater with inlet-outlet pipes facing up to ensure the heating elements will be immersed at all times to prevent premature failure. For liquid heating, outlet may be at either end. When heating gases the inlet should be closest to the terminal enclosure to minimize terminal box wiring temperatures.

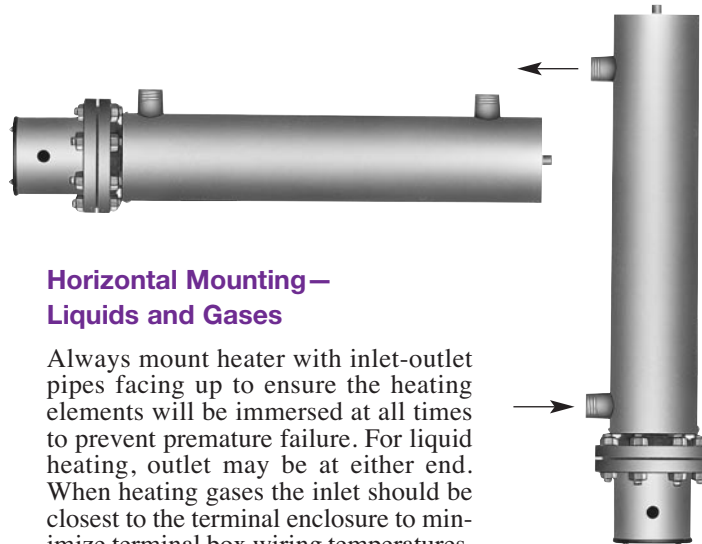

Vertical Mounting—Gases

Mount with terminal enclosure and inlet pipe at bottom of tank to minimize terminal box wiring temperatures.

Circulation Tank Assembly Maximum Immersed Element Length

Standard circulation heaters shown in the tables on pages 11-51 through 11-69 have element immersion lengths determined by the element wattage and element watt density. The screw plug or flange heater containing the elements is matched to a standard circulation heater tank assembly to assure proper heat transfer and heated material flow. When designing a system with a heater not

shown on these pages the table below can be used to select a tank size based on the calculated immersion length. If a standard tank size is not suitable for your installation, Tempco will design and manufacture a custom tank and heater assembly to satisfy the requirements of your application.

Nominal Pipe Size	Dimension Drawing Number	Maximum Immersed Element length	
		in	mm
1 1/4" NPT	1.1	18.0	457
	1.2	26.0	660
2 1/2" NPT	2.1	25.5	648
	2.2	35.5	902
	2.3	48.0	1219
3" Flange	3.1	28.0	711
	3.2	38.0	965
	3.3	50.5	1283
4" Flange	4.1	26.5	673
	4.2	37.0	940
	4.3	58.0	1473
	4.4	79.0	2007
5" Flange	5.1	36.0	914
	5.2	43.0	1092
	5.3	54.5	1384
	5.4	68.0	1727
	5.5	85.0	2159
6" Flange	6.1	26.5	673
	6.2	37.0	940
	6.3	58.0	1473
	6.4	79.0	2007

Nominal Pipe Size	Dimension Drawing Number	Maximum Immersed Element length	
		in	mm
8" Flange	8.1	32.5	826
	8.2	40.5	1029
	8.3	47.5	1207
	8.4	55.0	1397
	8.5	64.5	1638
	8.6	73.5	1867
	8.7	83.5	2121
10" Flange	10.1	60.0	1524
	10.2	67.0	1702
	10.3	73.0	1854
	10.4	82.0	2083
	10.5	90.0	2286
12" Flange	12.1	59.0	1499
	12.2	66.5	1689
	12.3	74.0	1880
	12.4	81.5	2070
	12.5	89.0	2261
14" Flange	14.1	58.0	1473
	14.2	65.5	1664
	14.3	73.0	1854
	14.4	80.5	2045
	14.5	88.0	2235

Standard (Non-Stock) Circulation Heaters

8 watts/in² (1.3 watts/cm²) — Typical Applications: Fuel Oils (Bunker C and Number 6)

- * Steel Screw Plug and Steel 150-lb Flanged Heater Sizes
- * Steel Sheath Heating Elements
- * Steel Tank
- * NEMA 1 Terminal Housing

NOTE: 3-Phase only. Cannot be rewired for single phase.

Nominal Pipe Size	Dimensional Drawing Number	KW	Part Number					Approximate Net Weight	
			120V	240V-1Ph (C*)	240V-3Ph (C*)	480V-1Ph (C*)	480V-3Ph (C*)	lbs	kgs
2 1/2" NPT	2.2	2	—	—	CHF01100 (1)	—	CHF01101 (1)	37	17
3 elements	2.3	3	—	—	CHF01102 (1)	—	CHF01103 (1)	46	21
3" — 150lb	3.2	2	—	—	CHF01104 (1)	—	CHF01105 (1)	62	28
3 elements	3.3	3	—	—	CHF01106 (1)	—	CHF01107 (1)	76	34

(C*) = Number of Branch Circuits per heater

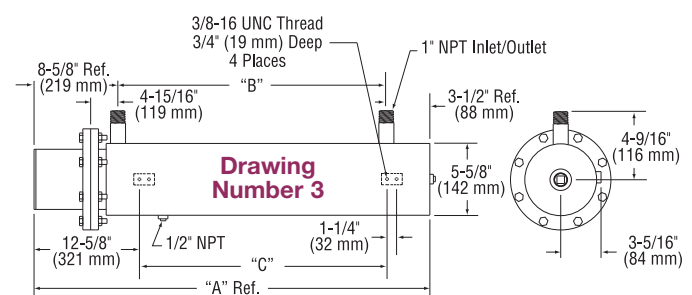
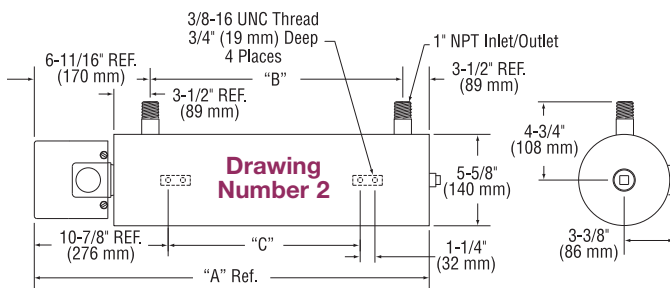

Dimensional Drawing Number

Drawing Number	"A"		"B"		"C"	
	in	mm	in	mm	in	mm
2.2	42-11/16	1084	32-1/2	826	26-1/2	673
2.3	55-3/16	1402	45	1143	39	991
3.2	44-5/8	1133	32-1/2	826	26-1/2	673
3.3	57-1/8	1451	45	1143	39	991

Ordering Information

See Page 11-69.

CONTINUED

Standard (Non-Stock) Circulation Heaters

Continued from previous page...

8 watts/in² (1.3 watts/cm²) — Typical Applications: Fuel Oils (Bunker C and Number 6)

- * Steel Screw Plug and Steel 150-lb Flanged Heater Sizes
- * Steel Tank

- * Steel Sheath Heating Elements
- * NEMA 1 Terminal Housing

NOTE: 3-Phase only. Cannot be rewired for single phase.

Nominal Pipe Size	Dimensional Drawing Number	KW	Part Number					Approximate Net Weight	
			120V	240V-1Ph (C*)	240V-3Ph (C*)	480V-1Ph (C*)	480V-3Ph (C*)	lbs	kgs
4" — 150lb 6 elements	4.3	5	—	—	CHF01108 (1)	—	CHF01109 (1)	117	53
	4.3	6	—	—	CHF01110 (1)	—	CHF01111 (1)	120	54
	4.4	8	—	—	CHF01112 (1)	—	CHF01113 (1)	147	67
	4.4	10	—	—	CHF01114 (1)	—	CHF01115 (1)	151	68
5" — 150lb 6 elements	5.2	5	—	—	CHF01116 (1)	—	CHF01117 (1)	128	58
	5.3	6	—	—	CHF01118 (1)	—	CHF01119 (1)	146	66
	5.4	8	—	—	CHF01120 (1)	—	CHF01121 (1)	172	78
	5.5	10	—	—	CHF01122 (1)	—	CHF01123 (1)	192	87
5" — 150lb 9 elements	5.2	7.5	—	—	CHF01124 (1)	—	CHF01125 (1)	135	61
	5.3	9	—	—	CHF01126 (1)	—	CHF01127 (1)	154	70
	5.4	12	—	—	CHF01128 (1)	—	CHF01129 (1)	183	83
	5.5	15	—	—	CHF01130 (1)	—	CHF01131 (1)	205	93
6" — 150lb 12 elements	6.2	8	—	—	CHF01132 (1)	—	CHF01133 (1)	157	71
	6.3	10	—	—	CHF01134 (1)	—	CHF01135 (1)	197	80
	6.3	12	—	—	CHF01136 (1)	—	CHF01137 (1)	202	92
	6.4	16.5	—	—	CHF01138 (1)	—	CHF01139 (1)	249	113
	6.4	20	—	—	CHF01140 (1)	—	CHF01141 (1)	257	117
6" — 150lb 15 elements	6.2	10	—	—	CHF01142 (1)	—	CHF01143 (1)	163	74
	6.3	12.5	—	—	CHF01144 (1)	—	CHF01145 (1)	204	93
	6.3	15	—	—	CHF01146 (1)	—	CHF01147 (1)	211	96
	6.4	21	—	—	CHF01148 (5)	—	CHF01149 (1)	260	118
	6.4	25	—	—	CHF01150 (5)	—	CHF01151 (1)	273	124
8" — 150lb 18 elements	8.3	12.5	—	—	CHF01152 (1)	—	CHF01153 (1)	272	123
	8.4	16.5	—	—	CHF01154 (1)	—	CHF01155 (1)	300	136
	8.5	20	—	—	CHF01156 (1)	—	CHF01157 (1)	334	151
	8.6	24	—	—	CHF01158 (2)	—	CHF01159 (1)	367	166
	8.7	27	—	—	CHF01160 (2)	—	CHF01161 (1)	402	182
8" — 150lb 24 elements	8.3	17	—	—	CHF01162 (1)	—	CHF01163 (1)	287	130
	8.4	22	—	—	CHF01164 (2)	—	CHF01165 (1)	318	144
	8.5	27	—	—	CHF01166 (2)	—	CHF01167 (1)	356	161
	8.6	32	—	—	CHF01168 (2)	—	CHF01169 (1)	386	175
	8.7	36	—	—	CHF01170 (2)	—	CHF01171 (1)	428	194
10" — 150lb 27 elements	10.3	30	—	—	CHF01172 (3)	—	CHF01173 (1)	537	244
	10.4	35	—	—	CHF01174 (3)	—	CHF01175 (1)	580	263
	10.5	40	—	—	CHF01176 (3)	—	CHF01177 (1)	623	283
12" — 150lb 36 elements	12.4	47	—	—	CHF01178 (3)	—	CHF01179 (2)	751	341
	12.5	54	—	—	CHF01180 (3)	—	CHF01181 (2)	793	360
14" — 150lb 45 elements	14.4	60	—	—	CHF01182 (3)	—	CHF01183 (3)	885	401
	14.5	67	—	—	CHF01184 (5)	—	CHF01185 (3)	941	427

(C*) = Number of Branch Circuits per heater

NOTE: Nominal Pipe Size 8" and larger are 7 watts/in² (1.1 watts/cm²)

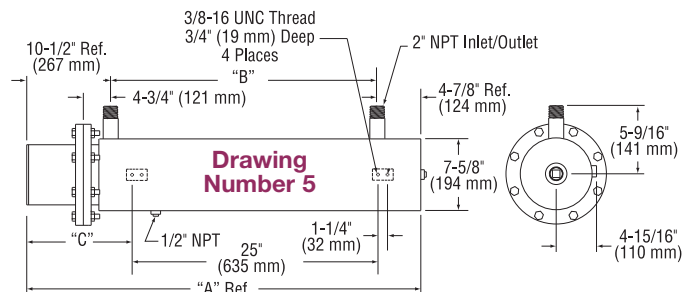
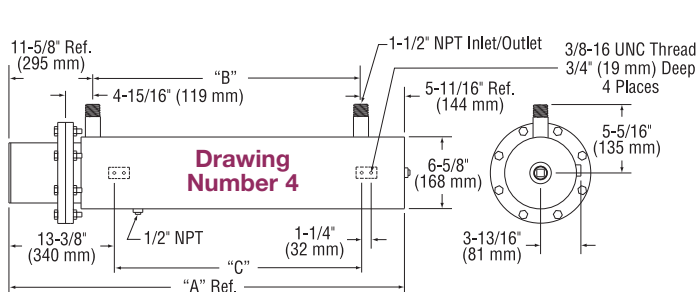

Standard (Non-Stock) Circulation Heaters

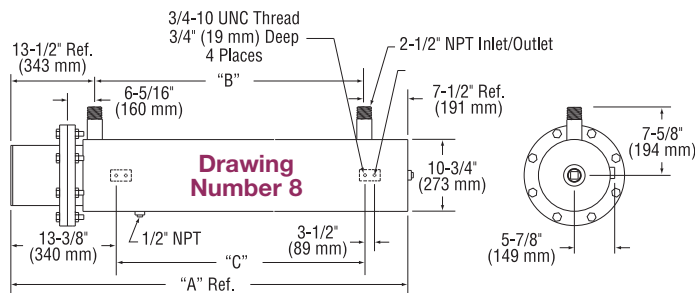
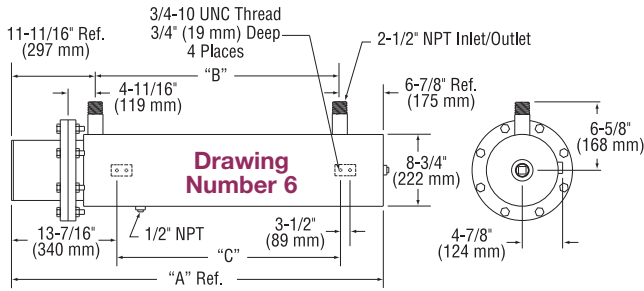

Dimensional Drawing Number

Drawing Number	"A"		"B"		"C"	
	in	mm	in	mm	in	mm
4.3	69-5/16	1761	52	1321	48-1/2	1232
4.4	90-5/16	2294	73	1854	69-1/2	1765
5.2	52-3/8	1330	37	940	15-1/4	387
5.3	63-7/8	1622	48-1/2	1232	21	533
5.4	77-1/4	1962	61-7/8	1572	27-1/2	698
5.5	90-1/4	2292	74-7/8	1902	34-1/4	870
6.2	49-9/16	1259	31	787	27-1/2	699
6.3	70-9/16	1792	52	1321	48-1/2	1232
6.4	91-9/16	2326	73	1854	69-1/2	1765
8.3	60-3/4	1543	39-11/16	1008	36-3/16	919
8.4	68-3/4	1746	47-5/16	1202	43-13/16	1113
8.5	77-7/8	1978	56-13/16	1443	53-5/16	1354
8.6	86-7/8	2207	65-13/16	1672	62-5/16	1583
8.7	96-7/8	2461	75-13/16	1926	72-5/16	1837
10.3	89	2261	75-1/4	1911	81	2057
10.4	96-1/2	2451	82-3/4	2102	88-1/2	2248
10.5	104	2642	90-1/4	2292	96	2438
12.4	96-3/4	2457	82-1/2	2096	88-5/8	2251
12.5	104-1/4	2648	90	2286	96-1/8	2442
14.4	97-1/8	2467	81-7/8	2080	88-3/4	2254
14.5	104-5/8	2657	89-3/8	2270	96-1/4	2445



Note: Circulation heater mounting lug design and location in the assembly drawings shown are standard. Designs can be modified to fit customer installation. Consult Tempco with your requirements.

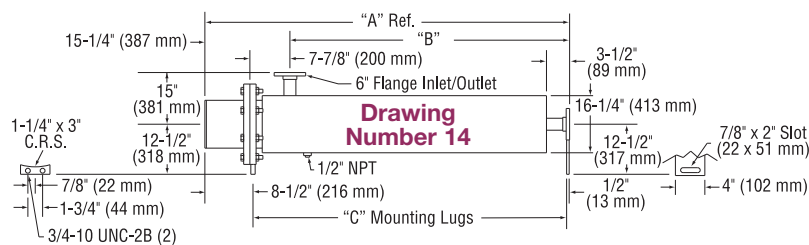
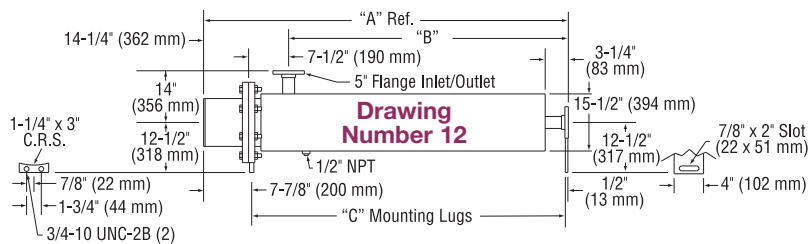
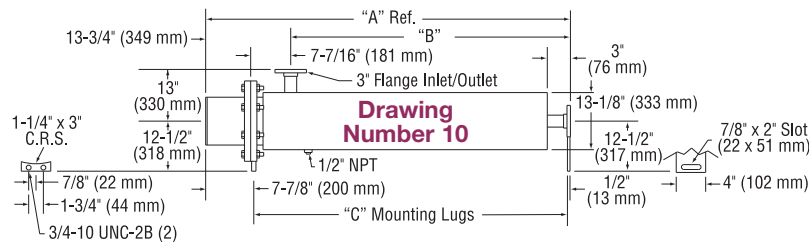

Ordering Information

See Page 11-69 for complete Ordering Information.



Circulation Heaters

Standard (Non-Stock) Circulation Heaters

23 watts/in² (3.6 watts/cm²) — Typical Applications: Lightweight Oils • Degreasing Solutions • Heat Transfer Oils

* Steel Screw Plug and Steel 150-lb Flanged Heater Sizes

* Steel Sheath Heating Elements

* Steel Tank

* NEMA 1 Terminal Housing

Nominal Pipe Size	Dimensional Drawing Number	KW	Part Number					Approximate Net Weight	
			120V	240V-1Ph (C*)	240V-3Ph (C*)	480V-1Ph (C*)	480V-3Ph (C*)	lbs	kg
1¼" NPT 2 elements	1.1	1.5	CHF01186	CHF01187 (1)	—	—	—	14	6
	1.2	2	CHF01188	CHF01189 (1)	—	—	—	18	8
2½" NPT 3 elements	2.1	3	—	CHF01190 (1)	CHF01191 (1)	CHF01192 (1)	CHF01193 (1)	28	13
	2.1	4.5	—	CHF01194 (1)	CHF01195 (1)	CHF01196 (1)	CHF01197 (1)	29	13
	2.2	6	—	CHF01198 (1)	CHF01199 (1)	CHF01200 (1)	CHF01201 (1)	37	17
	2.3	7.5	—	CHF01202 (1)	CHF01203 (1)	CHF01204 (1)	CHF01205 (1)	45	20
	2.3	9	—	CHF01206 (1)	CHF01207 (1)	CHF01208 (1)	CHF01209 (1)	46	21
3" — 150lb 3 elements	3.1	3	—	CHF01210 (1)	CHF01211 (1)	CHF01212 (1)	CHF01213 (1)	53	24
	3.1	4.5	—	CHF01214 (1)	CHF01215 (1)	CHF01216 (1)	CHF01217 (1)	54	24
	3.2	6	—	CHF01218 (1)	CHF01219 (1)	CHF01220 (1)	CHF01221 (1)	62	28
	3.3	7.5	—	CHF01222 (1)	CHF01223 (1)	CHF01224 (1)	CHF01225 (1)	74	34
	3.3	9	—	CHF01226 (1)	CHF01227 (1)	CHF01228 (1)	CHF01229 (1)	76	34
4" — 150lb 6 elements	4.1	6	—	CHF01230 (1)	CHF01231 (1)	CHF01232 (1)	CHF01233 (1)	78	35
	4.1	9	—	CHF01234 (1)	CHF01235 (1)	CHF01236 (1)	CHF01237 (1)	91	41
	4.2	12	—	CHF01238 (2)	CHF01239 (1)	CHF01240 (1)	CHF01241 (1)	94	43
	4.3	15	—	CHF01242 (2)	CHF01243 (1)	CHF01244 (1)	CHF01245 (1)	117	53
	4.3	18	—	CHF01246 (2)	CHF01247 (1)	CHF01248 (1)	CHF01249 (1)	120	54
	4.4	25	—	—	CHF01250 (2)	CHF01251 (2)	CHF01252 (1)	147	67
	4.4	30	—	—	CHF01253 (2)	CHF01254 (2)	CHF01255 (1)	151	68
5" — 150lb 6 elements	5.2	12	—	CHF01256 (2)	CHF01257 (1)	CHF01258 (1)	CHF01259 (1)	126	57
	5.2	15	—	CHF01260 (2)	CHF01261 (1)	CHF01262 (1)	CHF01263 (1)	128	58
	5.3	18	—	CHF01264 (2)	CHF01265 (1)	CHF01266 (1)	CHF01267 (1)	146	66
	5.3	20	—	CHF01268 (2)	CHF01269 (1)	CHF01270 (1)	CHF01271 (1)	147	67
	5.4	25	—	—	CHF01272 (2)	CHF01273 (2)	CHF01274 (1)	172	78
	5.5	30	—	—	CHF01275 (2)	CHF01276 (2)	CHF01277 (1)	192	87
5" — 150lb 9 elements	5.2	18	—	CHF01278 (3)	CHF01279 (1)	CHF01280 (1)	CHF01281 (1)	132	60
	5.2	23	—	CHF01282 (3)	CHF01283 (3)	CHF01284 (1)	CHF01285 (1)	135	61
	5.3	27	—	CHF01286 (3)	CHF01287 (3)	CHF01288 (3)	CHF01289 (1)	154	70
	5.4	38	—	—	CHF01290 (3)	CHF01291 (3)	CHF01292 (1)	183	83
	5.5	45	—	—	CHF01293 (3)	CHF01294 (3)	CHF01295 (3)	205	93
6" — 150lb 12 elements	6.1	12	—	CHF01296 (1)	CHF01297 (1)	CHF01298 (1)	CHF01299 (1)	127	58
	6.2	18	—	CHF01300 (2)	CHF01301 (1)	CHF01302 (1)	CHF01303 (1)	152	69
	6.2	24	—	CHF01304 (2)	CHF01305 (2)	CHF01306 (1)	CHF01307 (1)	157	71
	6.3	30	—	CHF01308 (2)	CHF01309 (2)	CHF01310 (2)	CHF01311 (1)	197	89
	6.3	36	—	CHF01312 (3)	CHF01313 (2)	CHF01314 (2)	CHF01315 (1)	202	92
	6.4	50	—	—	CHF01316 (4)	CHF01317 (3)	CHF01318 (2)	249	113
	6.4	60	—	—	CHF01319 (4)	CHF01320 (3)	CHF01321 (2)	257	117
6" — 150lb 15 elements	6.1	15	—	CHF01322 (3)	CHF01323 (1)	CHF01324 (1)	CHF01325 (1)	130	59
	6.2	23	—	CHF01326 (3)	CHF01327 (5)	CHF01328 (1)	CHF01329 (1)	156	71
	6.2	30	—	CHF01330 (3)	CHF01331 (5)	CHF01332 (3)	CHF01333 (1)	163	74
	6.3	38	—	CHF01334 (5)	CHF01335 (5)	CHF01336 (3)	CHF01337 (1)	204	93
	6.3	45	—	CHF01338 (5)	CHF01339 (5)	CHF01340 (3)	CHF01341 (5)	211	96
	6.4	63	—	—	CHF01342 (5)	CHF01343 (3)	CHF01344 (5)	260	118
	6.4	75	—	—	CHF01345 (5)	CHF01346 (5)	CHF01347 (5)	270	122
	8.2	30	—	CHF01348 (3)	CHF01349 (2)	CHF01350 (2)	CHF01351 (1)	241	109
	8.3	40	—	—	CHF01352 (2)	CHF01353 (2)	CHF01354 (1)	272	123
8" — 150lb 18 elements	8.4	50	—	—	CHF01355 (3)	CHF01356 (3)	CHF01357 (2)	300	136
	8.5	60	—	—	CHF01358 (3)	CHF01359 (3)	CHF01360 (2)	334	151
	8.6	70	—	—	CHF01361 (6)	CHF01362 (3)	CHF01363 (2)	367	166
	8.7	80	—	—	CHF01364 (6)	—	CHF01365 (2)	402	182
	8" — 150lb 24 elements	8.2	40	—	CHF01366 (4)	CHF01367 (2)	CHF01368 (2)	CHF01369 (1)	253
8.3		53	—	—	CHF01370 (4)	CHF01371 (3)	CHF01372 (2)	287	130
8.4		67	—	—	CHF01373 (4)	CHF01374 (3)	CHF01375 (2)	318	144
8.5		80	—	—	CHF01376 (4)	CHF01377 (4)	CHF01378 (2)	356	161
8.6		93	—	—	CHF01379 (8)	CHF01380 (6)	CHF01381 (4)	392	178
8.7		107	—	—	CHF01382 (8)	—	CHF01383 (4)	428	194

(C*) = Number of Branch Circuits per heater

NOTE: Nominal Pipe Size 8" and larger are 20 watts/in² (3.1 watts/cm²)

[View Product Inventory @ www.tempco.com](http://www.tempco.com)

Standard (Non-Stock) Circulation Heaters

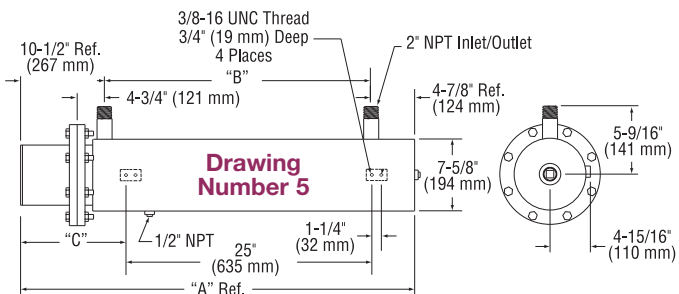
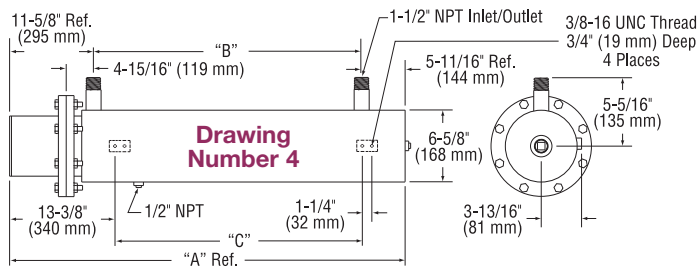
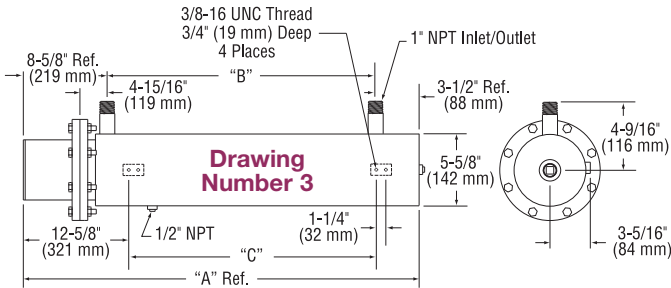
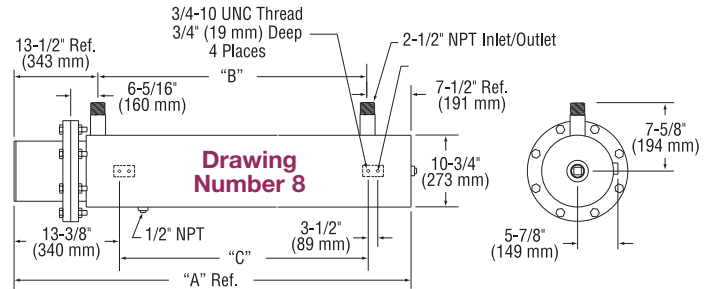
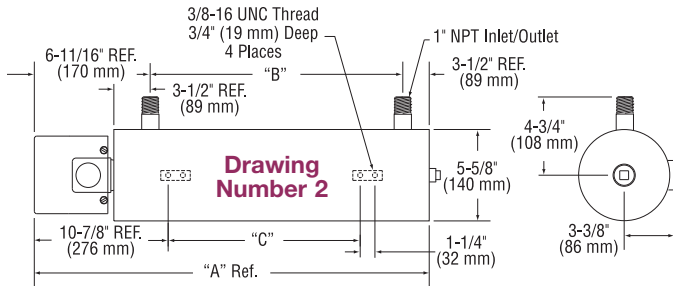
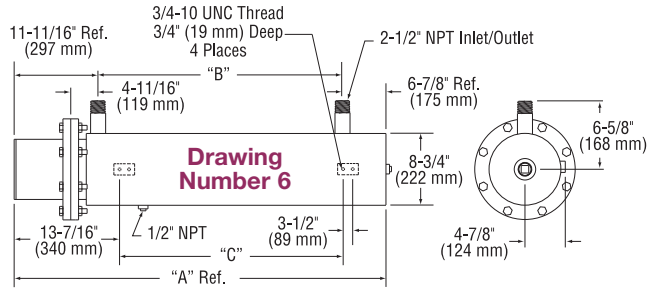
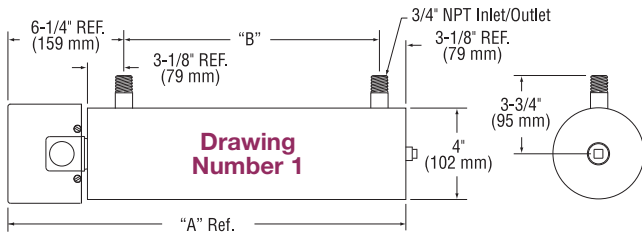

Dimensional Drawing Number

Drawing Number	"A"		"B"		"C"	
	in	mm	in	mm	in	mm—
1.1	24-3/8	619	15	381	—	—
1.2	32-3/8	822	23	584	—	—
2.1	32-11/16	830	22-1/2	572	16-1/2	419
2.2	42-11/16	1084	32-1/2	826	26-1/2	673
2.3	55-3/16	1402	45	1143	39	991
3.1	34-5/8	879	22-1/2	572	16-1/2	419
3.2	44-5/8	1133	32-1/2	826	26-1/2	673
3.3	57-1/8	1451	45	1143	39	991
4.1	37-13/16	960	20-1/2	521	17	432
4.2	48-5/16	1227	31	787	27-1/2	699
4.3	69-5/16	1761	52	1321	48-1/2	1232
4.4	90-5/16	2294	73	1854	69-1/2	1765
5.2	52-3/8	1330	37	940	15-1/4	387
5.3	63-7/8	1622	48-1/2	1232	21	533
5.4	77-1/4	1962	61-7/8	1572	27-1/2	698
5.5	90-1/4	2292	74-7/8	1902	34-1/4	870
6.1	39-1/16	992	20-1/2	521	17	432
6.2	49-9/16	1259	31	787	27-1/2	699
6.3	70-9/16	1792	52	1321	48-1/2	1232
6.4	91-9/16	2326	73	1854	69-1/2	1765
8.2	53-3/4	1365	32-11/16	830	29-3/16	741
8.3	60-3/4	1543	39-11/16	1008	36-3/16	919
8.4	68-3/4	1746	47-5/16	1202	43-13/16	1113
8.5	77-7/8	1978	56-13/16	1443	53-5/16	1354
8.6	86-7/8	2207	65-13/16	1672	62-5/16	1583
8.7	96-7/8	2461	75-13/16	1926	72-5/16	1837



Note: Circulation heater mounting lug design and location in the assembly drawings shown are standard. Designs can be modified to fit customer installation. Consult Tempco with your requirements.

Ordering Information

See Page 11-69 for complete Ordering Information.

CONTINUED 

Circulation Heaters

Standard (Non-Stock) Circulation Heaters

Continued from previous page...

23 watts/in² (3.6 watts/cm²) — Typical Applications: Lightweight Oils • Degreasing Solutions • Heat Transfer Oils

- * Steel Screw Plug and Steel 150-lb Flanged Heater Sizes
- * Steel Tank

- * Steel Sheath Heating Elements
- * NEMA 1 Terminal Housing

Nominal Pipe Size	Dimensional Drawing Number	KW	Part Number				Approximate Net Weight		
			120V	240V-1Ph (C*)	240V-3Ph (C*)	480V-1Ph (C*)	480V-3Ph (C*)	lbs	kgs
10" - 150lb 27 elements	10.3	90	—	—	—	—	CHF01384 (3)	537	244
	10.4	105	—	—	—	—	CHF01385 (3)	580	263
	10.5	120	—	—	—	—	CHF01386 (3)	623	283
12" - 150lb 36 elements	12.4	140	—	—	—	—	CHF01387 (4)	751	341
	12.5	160	—	—	—	—	CHF01388 (4)	793	360
14" - 150lb 45 elements	14.3	150	—	—	—	—	CHF01389 (5)	824	374
	14.4	175	—	—	—	—	CHF01390 (5)	885	401
	14.5	200	—	—	—	—	CHF01391 (5)	941	427

(C*) = Number of Branch Circuits per heater

NOTE: Nominal Pipe Size 8" and larger are 20 watts/in² (3.1 watts/cm²)



Note: Circulation heater mounting lug design and location in the assembly drawings shown are standard. Designs can be modified to fit customer installation.

Consult Tempco with your requirements.

Dimensional Drawing Number

Drawing Number	"A"		"B"		"C"	
	in	mm	in	mm	in	mm
10.3	89	2261	75-1/4	1911	81	2057
10.4	96-1/2	2451	82-3/4	2102	88-1/2	2248
10.5	104	2642	90-1/4	2292	96	2438
12.4	96-3/4	2457	82-1/2	2096	88-5/8	2251
12.5	104-1/4	2648	90	2286	96-1/8	2442
14.3	89-5/8	2276	74-3/8	1889	81-1/4	2064
14.4	97-1/8	2467	81-7/8	2080	88-3/4	2254
14.5	104-5/8	2657	89-3/8	2270	96-1/4	2445

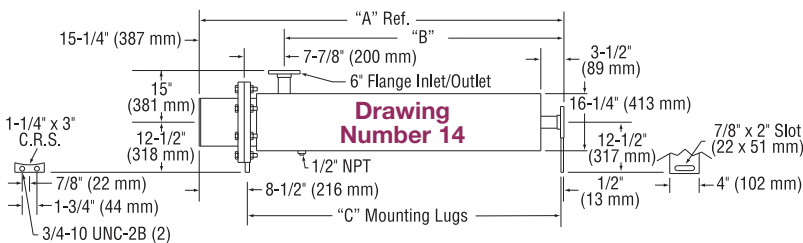
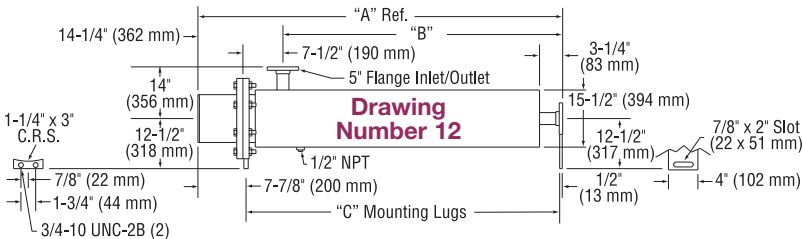
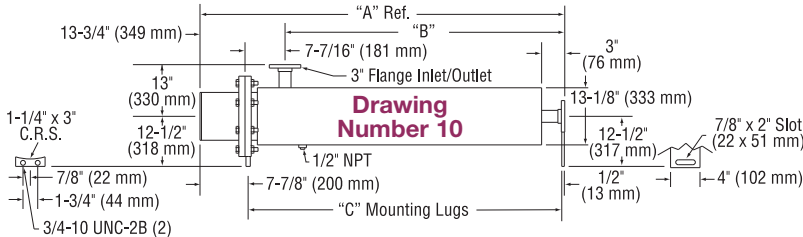

Ordering Information

See Page 11-69 for complete Ordering Information.

Standard (Non-Stock) Circulation Heaters

16 watts/in² (2.5 watts/cm²) — Typical Applications: Medium Weight Oils • Heat Transfer Oils • Liquid Paraffin

* 304 Stainless Steel Screw Plug and Steel 150-lb Flanged Heater Sizes

* Steel Tank

* Incoloy®800 Sheath Heating Elements

* NEMA 1 Terminal Housing

NOTE: 3-Phase only. Cannot be rewired for single phase.

Nominal Pipe Size	Dimensional Drawing Number	KW	Part Number					Approximate Net Weight	
			120V	240V-1Ph (C*)	240V-3Ph (C*)	480V-1Ph (C*)	480V-3Ph (C*)	lbs	kgs
2½" NPT 3 elements	2.1	2	—	—	CHF01392 (1)	—	CHF01393 (1)	28	13
	2.1	2.5	—	—	CHF01394 (1)	—	CHF01395 (1)	29	13
	2.1	3	—	—	CHF01396 (1)	—	CHF01397 (1)	30	14
	2.2	4	—	—	CHF01398 (1)	—	CHF01399 (1)	37	17
	2.3	5	—	—	CHF01400 (1)	—	CHF01401 (1)	45	20
	2.3	6	—	—	CHF01402 (1)	—	CHF01403 (1)	46	21
3"-150lb 3 elements	3.1	2	—	—	CHF01404 (1)	—	CHF01405 (1)	53	24
	3.1	2.5	—	—	CHF01406 (1)	—	CHF01407 (1)	53	24
	3.2	3	—	—	CHF01408 (1)	—	CHF01409 (1)	61	28
	3.2	4	—	—	CHF01410 (1)	—	CHF01411 (1)	62	28
	3.3	5	—	—	CHF01412 (1)	—	CHF01413 (1)	74	34
	3.3	6	—	—	CHF01414 (1)	—	CHF01415 (1)	76	34

(C*) = Number of Branch Circuits per heater

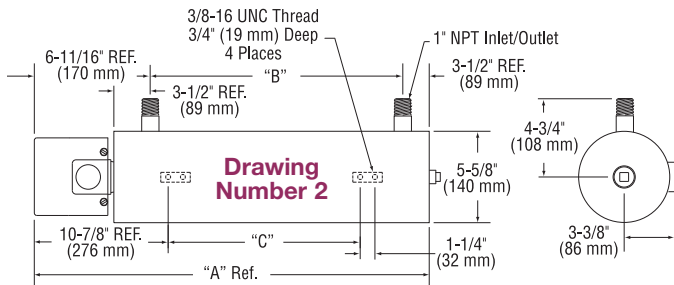

Dimensional Drawing Number

Drawing Number	"A"		"B"		"C"	
	in	mm	in	mm	in	mm
2.1	32-11/16	830	22-1/2	572	16-1/2	419
2.2	42-11/16	1084	32-1/2	826	26-1/2	673
2.3	55-3/16	1402	45	1143	39	991
3.1	34-5/8	879	22-1/2	572	16-1/2	419
3.2	44-5/8	1133	32-1/2	826	26-1/2	673
3.3	57-1/8	1451	45	1143	39	991

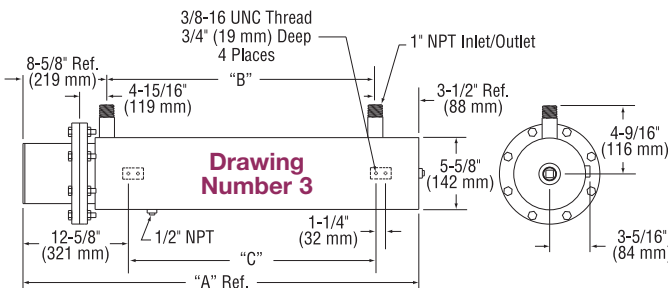

Note: Circulation heater mounting lug design and location in the assembly drawings shown are standard. Designs can be modified to fit customer installation. Consult Tempco with your requirements.



CONTINUED →

Circulation Heaters

Standard (Non-Stock) Circulation Heaters

Continued from previous page...

16 watts/in² (2.5 watts/cm²) — Typical Applications: Medium Weight Oils • Heat Transfer Oils • Liquid Paraffin

NOTE: 3-Phase only. Cannot be rewired for single phase.

Nominal Pipe Size	Dimensional Drawing Number	KW	Part Number				Approximate Net Weight		
			120V	240V-1Ph (C*)	240V-3Ph (C*)	480V-1Ph (C*)	480V-3Ph (C*)	lbs	kgs
4"-150lb 6 elements	4.1	3	—	—	CHF01416 (1)	—	CHF01417 (1)	76	34
	4.1	4	—	—	CHF01418 (1)	—	CHF01419 (1)	78	35
	4.1	5	—	—	CHF01420 (1)	—	CHF01421 (1)	79	36
	4.2	6	—	—	CHF01422 (1)	—	CHF01423 (1)	91	41
	4.2	8	—	—	CHF01424 (1)	—	CHF01425 (1)	94	43
	4.3	10	—	—	CHF01426 (1)	—	CHF01427 (1)	117	53
	4.3	12	—	—	CHF01428 (1)	—	CHF01429 (1)	120	54
5"-150lb 6 elements	5.1	8	—	—	CHF01430 (1)	—	CHF01431 (1)	117	53
	5.2	10	—	—	CHF01432 (1)	—	CHF01433 (1)	128	58
	5.3	12	—	—	CHF01434 (1)	—	CHF01435 (1)	146	66
5"-150lb 9 elements	5.1	12	—	—	CHF01436 (1)	—	CHF01437 (1)	123	56
	5.2	15	—	—	CHF01438 (1)	—	CHF01439 (1)	135	61
	5.3	18	—	—	CHF01440 (1)	—	CHF01441 (1)	154	70
6"-150lb 12 elements	6.1	6	—	—	CHF01442 (1)	—	CHF01443 (1)	124	56
	6.1	8	—	—	CHF01444 (1)	—	CHF01445 (1)	127	58
	6.1	10	—	—	CHF01446 (1)	—	CHF01447 (1)	129	59
	6.2	12	—	—	CHF01448 (1)	—	CHF01449 (1)	152	69
	6.2	16	—	—	CHF01450 (1)	—	CHF01451 (1)	157	71
	6.3	20	—	—	CHF01452 (1)	—	CHF01453 (1)	197	89
	6.3	24	—	—	CHF01454 (2)	—	CHF01455 (1)	202	92
6"-150lb 15 elements	6.1	7.5	—	—	CHF01456 (1)	—	CHF01457 (1)	126	57
	6.1	10	—	—	CHF01458 (1)	—	CHF01459 (1)	130	59
	6.1	12.5	—	—	CHF01460 (1)	—	CHF01461 (1)	133	60
	6.2	15	—	—	CHF01462 (1)	—	CHF01463 (1)	156	71
	6.2	20	—	—	CHF01464 (1)	—	CHF01465 (1)	163	74
	6.3	25	—	—	CHF01466 (5)	—	CHF01467 (1)	164	74
	6.3	30	—	—	CHF01468 (5)	—	CHF01469 (1)	211	96
8"-150lb 18 elements	8.2	17	—	—	CHF01470 (1)	—	CHF01471 (1)	234	106
	8.3	25	—	—	CHF01472 (2)	—	CHF01473 (1)	264	120
	8.4	33	—	—	CHF01474 (2)	—	CHF01475 (1)	293	133
	8.5	42	—	—	CHF01476 (3)	—	CHF01477 (2)	327	148
	8.6	50	—	—	—	—	CHF01478 (2)	360	163
	8.7	58	—	—	—	—	CHF01479 (2)	395	179
	8.7	67	—	—	—	—	CHF01480 (2)	405	184
8"-150lb 24 elements	8.2	23	—	—	CHF01481 (2)	—	CHF01482 (1)	243	110
	8.3	33	—	—	CHF01483 (2)	—	CHF01484 (1)	277	126
	8.4	44	—	—	CHF01485 (4)	—	CHF01486 (2)	308	140
	8.5	56	—	—	CHF01487 (4)	—	CHF01488 (2)	346	157
	8.6	67	—	—	—	—	CHF01489 (2)	382	173
	8.7	77	—	—	—	—	CHF01490 (2)	420	191
	8.7	89	—	—	—	—	CHF01491 (4)	433	196
10"-150lb 27 elements	10.3	75	—	—	—	—	CHF01492 (3)	539	244
	10.5	87	—	—	—	—	CHF01493 (3)	615	279
12"-150lb 36 elements	12.3	100	—	—	—	—	CHF01494 (3)	694	315
	12.5	117	—	—	—	—	CHF01495 (3)	782	355
14"-150lb 45 elements	14.2	105	—	—	—	—	CHF01496 (3)	771	350
	14.3	125	—	—	—	—	CHF01497 (5)	828	376

(C*) = Number of Branch Circuits per heater

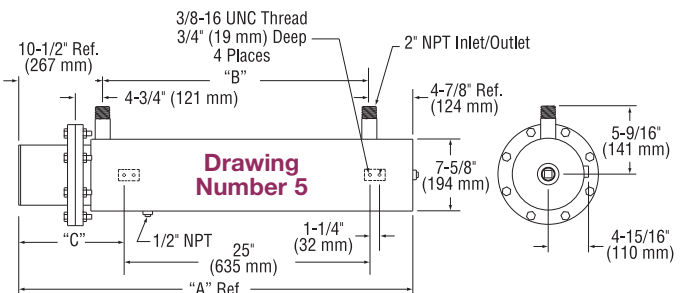
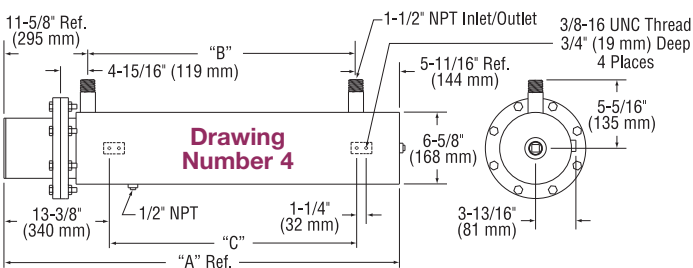

Standard (Non-Stock) Circulation Heaters

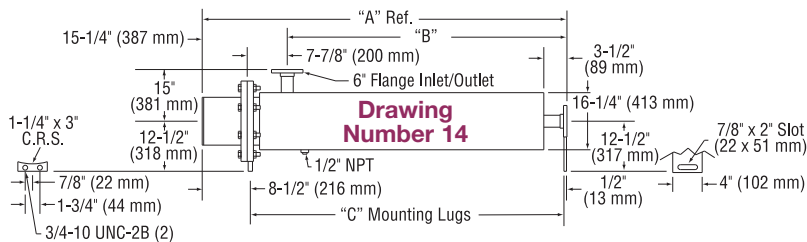
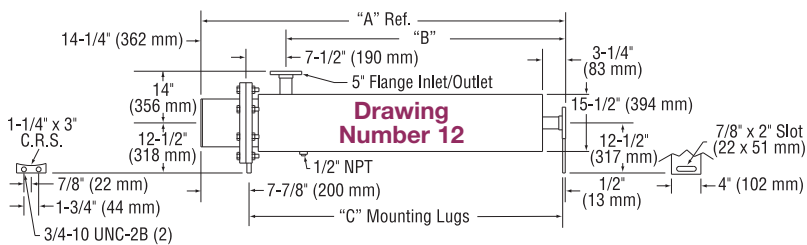
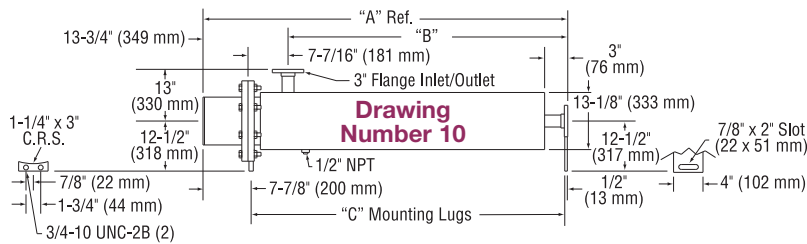
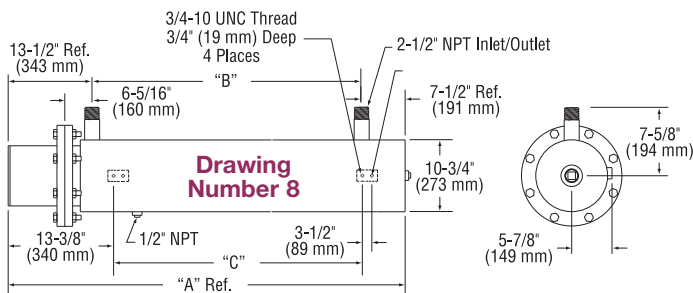
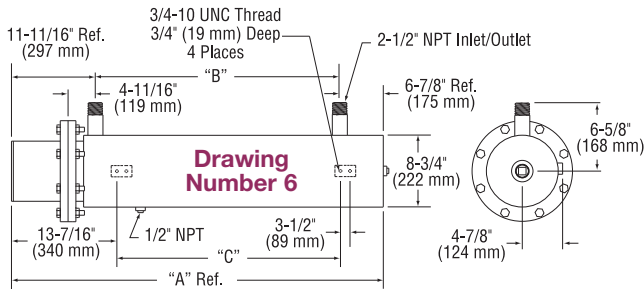

Dimensional Drawing Number

Drawing Number	"A"		"B"		"C"	
	in	mm	in	mm	in	mm
4.1	37-13/16	960	20-1/2	521	17	432
4.2	48-5/16	1227	31	787	27-1/2	699
4.3	69-5/16	1761	52	1321	48-1/2	1232
5.1	45-3/8	1153	30	762	11-1/2	292
5.2	52-3/8	1330	37	940	15-1/4	387
5.3	63-7/8	1622	48-1/2	1232	21	533
6.1	39-1/16	992	20-1/2	521	17	432
6.2	49-9/16	1259	31	787	27-1/2	699
6.3	70-9/16	1792	52	1321	48-1/2	1232
8.2	53-3/4	1365	32-11/16	830	29-3/16	741
8.3	60-3/4	1543	39-11/16	1008	36-3/16	919
8.4	68-3/4	1746	47-5/16	1202	43-13/16	1113
8.5	77-7/8	1978	56-13/16	1443	53-5/16	1354
8.6	86-7/8	2207	65-13/16	1672	62-5/16	1583
8.7	96-7/8	2461	75-13/16	1926	72-5/16	1837
10.3	89	2261	75-1/4	1911	81	2057
10.5	104	2642	90-1/4	2292	96	2438
12.3	89-1/4	2267	75	1905	81-1/8	2061
12.5	104-1/4	2648	90	2286	96-1/8	2442
14.2	82-1/8	2086	66-7/8	1699	73-3/4	1873
14.3	89-5/8	2276	74-3/8	1889	81-1/4	2064



Note: Circulation heater mounting lug design and location in the assembly drawings shown are standard. Designs can be modified to fit customer installation.

Consult Tempco with your requirements.



Circulation heater with optional externally mounted thermostat.

Ordering Information

See Page 11-69 for complete Ordering Information.



Circulation Heaters

Standard (Non-Stock) Circulation Heaters

23 watts/in² (3.6 watts/cm²) — Typical Applications: Forced Air & Gases • Caustic Solutions • Degreasing Solutions

* 304 Stainless Steel Screw Plug and Steel 150-lb Flanged Heater Sizes

* Incoloy® 800 Sheath Heating Elements

* Steel Tank

* NEMA 1 Terminal Housing

Nominal Pipe Size	Dimensional Drawing Number	KW	Part Number					Approximate Net Weight	
			120V	240V-1Ph (C*)	240V-3Ph (C*)	480V-1Ph (C*)	480V-3Ph (C*)	lbs	kgs
1½" NPT 2 elements	1.1	1	CHF01498	CHF01499 (1)	—	—	—	13	6
	1.1	1.5	CHF01500	CHF01501 (1)	—	—	—	13	6
	1.2	2	CHF01502	CHF01503 (1)	—	—	—	17	8
2½" NPT 3 elements	2.1	3	—	CHF01504 (1)	CHF01505 (1)	CHF01506 (1)	CHF01507 (1)	28	13
	2.2	4.5	—	CHF01508 (1)	CHF01509 (1)	CHF01510 (1)	CHF01511 (1)	35	16
	2.2	6	—	CHF01512 (1)	CHF01513 (1)	CHF01514 (1)	CHF01515 (1)	37	17
	2.3	7.5	—	CHF01516 (1)	CHF01517 (1)	CHF01518 (1)	CHF01519 (1)	45	20
	2.3	9	—	CHF01520 (1)	CHF01521 (1)	CHF01522 (1)	CHF01523 (1)	46	21
3"-150lb 3 elements	3.1	3	—	CHF01524 (1)	CHF01525 (1)	CHF01526 (1)	CHF01527 (1)	53	24
	3.2	4.5	—	CHF01528 (1)	CHF01529 (1)	CHF01530 (1)	CHF01531 (1)	61	28
	3.2	6	—	CHF01532 (1)	CHF01533 (1)	CHF01534 (1)	CHF01535 (1)	62	28
	3.3	7.5	—	CHF01536 (1)	CHF01537 (1)	CHF01538 (1)	CHF01539 (1)	74	34
	3.3	9	—	CHF01540 (1)	CHF01541 (1)	CHF01542 (1)	CHF01543 (1)	76	34
4"-150lb 6 elements	4.1	6	—	CHF01544 (1)	CHF01545 (1)	CHF01546 (1)	CHF01547 (1)	78	35
	4.2	9	—	CHF01548 (1)	CHF01549 (1)	CHF01550 (1)	CHF01551 (1)	91	41
	4.2	12	—	CHF01552 (2)	CHF01553 (1)	CHF01554 (1)	CHF01555 (1)	94	43
	4.3	15	—	CHF01556 (2)	CHF01557 (1)	CHF01558 (1)	CHF01559 (1)	117	53
	4.3	18	—	CHF01560 (2)	CHF01561 (1)	CHF01562 (1)	CHF01563 (1)	120	54
	4.4	25	—	—	CHF01564 (2)	CHF01565 (2)	CHF01566 (1)	147	67
5"-150lb 6 elements	4.4	30	—	—	CHF01567 (2)	CHF01568 (2)	CHF01569 (1)	151	68
	5.1	9	—	CHF01570 (1)	CHF01571 (1)	CHF01572 (1)	CHF01573 (1)	114	52
	5.2	12	—	CHF01574 (2)	CHF01575 (1)	CHF01576 (1)	CHF01577 (1)	126	57
	5.2	15	—	CHF01578 (2)	CHF01579 (1)	CHF01580 (1)	CHF01581 (1)	128	58
	5.3	18	—	CHF01582 (2)	CHF01583 (1)	CHF01584 (1)	CHF01585 (1)	146	66
	5.4	25	—	—	CHF01586 (2)	CHF01587 (2)	CHF01588 (1)	172	78
5"-150lb 9 elements	5.5	30	—	—	CHF01589 (2)	CHF01590 (2)	CHF01591 (1)	192	87
	5.1	14	—	CHF01592 (3)	CHF01593 (1)	CHF01594 (1)	CHF01595 (1)	119	54
	5.2	18	—	CHF01596 (3)	CHF01597 (1)	CHF01598 (1)	CHF01599 (1)	132	60
	5.2	23	—	CHF01600 (3)	CHF01601 (3)	CHF01602 (1)	CHF01603 (1)	135	61
	5.3	27	—	CHF01604 (3)	CHF01605 (3)	CHF01606 (3)	CHF01607 (1)	150	68
	5.4	38	—	—	CHF01608 (3)	CHF01609 (3)	CHF01610 (1)	183	83
6"-150lb 12 elements	5.5	45	—	—	CHF01611 (3)	CHF01612 (3)	CHF01613 (3)	205	93
	6.1	12	—	CHF01614 (2)	CHF01615 (1)	CHF01616 (1)	CHF01617 (1)	127	58
	6.2	18	—	CHF01618 (2)	CHF01619 (1)	CHF01620 (1)	CHF01621 (1)	152	69
	6.2	24	—	CHF01622 (2)	CHF01623 (2)	CHF01624 (2)	CHF01625 (1)	157	71
	6.3	30	—	CHF01626 (3)	CHF01627 (2)	CHF01628 (2)	CHF01629 (1)	197	89
	6.3	36	—	CHF01630 (3)	CHF01631 (2)	CHF01632 (2)	CHF01633 (1)	202	92
	6.4	50	—	—	CHF01634 (4)	CHF01635 (4)	CHF01636 (2)	249	113
6.4	60	—	—	CHF01637 (4)	CHF01638 (4)	CHF01639 (2)	257	117	
6"-150lb 15 elements	6.1	15	—	CHF01640 (3)	CHF01641 (1)	CHF01642 (1)	CHF01643 (1)	130	59
	6.2	23	—	CHF01644 (3)	CHF01645 (5)	CHF01646 (1)	CHF01647 (1)	156	71
	6.2	30	—	CHF01648 (3)	CHF01649 (5)	CHF01650 (3)	CHF01651 (1)	163	74
	6.3	38	—	CHF01652 (5)	CHF01653 (5)	CHF01654 (3)	CHF01655 (1)	204	93
	6.3	45	—	CHF01656 (5)	CHF01657 (5)	CHF01658 (3)	CHF01659 (5)	211	96
	6.4	63	—	—	CHF01660 (5)	CHF01661 (3)	CHF01662 (5)	260	118
	6.4	75	—	—	CHF01663 (5)	CHF01664 (5)	CHF01665 (5)	270	122
8"-150lb 18 elements	8.2	30	—	CHF01666 (3)	CHF01667 (2)	CHF01668 (2)	CHF01669 (1)	244	111
	8.3	40	—	—	CHF01670 (2)	CHF01671 (2)	CHF01672 (1)	274	124
	8.4	50	—	—	CHF01673 (3)	CHF01674 (3)	CHF01675 (2)	303	137
8"-150lb 24 elements	8.2	40	—	CHF01676 (4)	CHF01677 (2)	CHF01678 (2)	CHF01679 (1)	253	115
	8.3	53	—	—	CHF01680 (4)	CHF01681 (3)	CHF01682 (2)	287	130
	8.4	67	—	—	CHF01683 (4)	CHF01684 (3)	CHF01685 (2)	318	144

(C*) = Number of Branch Circuits per heater

NOTE: Nominal Pipe Size 8" and larger are 20 watts/in² (3.1 watts/cm²)

Standard (Non-Stock) Circulation Heaters

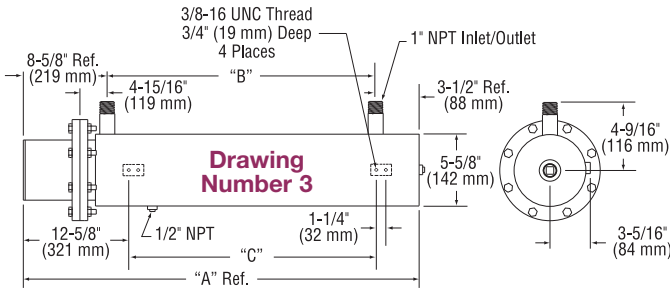
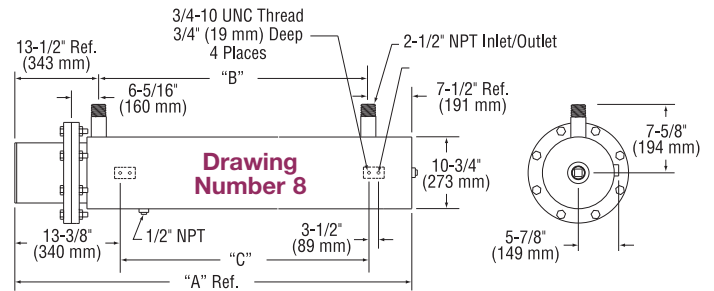
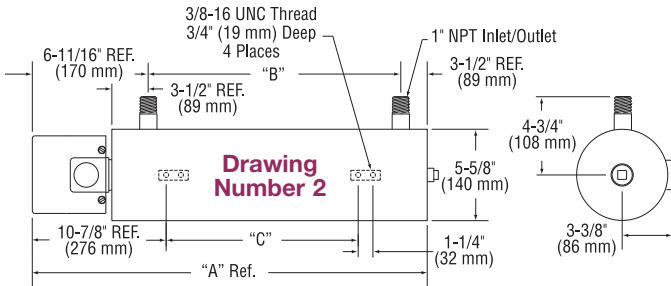
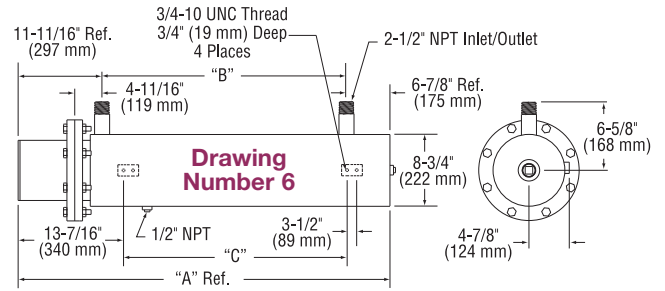
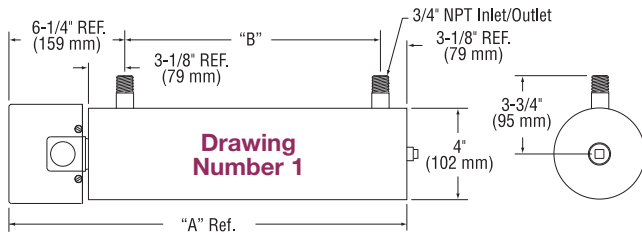

Dimensional Drawing Number

Drawing Number	"A"		"B"		"C"	
	in	mm	in	mm	in	mm
1.1	24-3/8	619	15	381		
1.2	32-3/8	822	23	584		
2.1	32-11/16	830	22-1/2	572	16-1/2	419
2.2	42-11/16	1084	32-1/2	826	26-1/2	673
2.3	55-3/16	1402	45	1143	39	991
3.1	34-5/8	879	22-1/2	572	16-1/2	419
3.2	44-5/8	1133	32-1/2	826	26-1/2	673
3.3	57-1/8	1451	45	1143	39	991
4.1	37-13/16	960	20-1/2	521	17	432
4.2	48-5/16	1227	31	787	27-1/2	699
4.3	69-5/16	1761	52	1321	48-1/2	1232
4.4	90-5/16	2294	73	1854	69-1/2	1765
5.1	45-3/8	1153	30	762	11-1/2	292
5.2	52-3/8	1330	37	940	15-1/4	387
5.3	63-7/8	1622	48-1/2	1232	21	533
5.4	77-1/4	1962	61-7/8	1572	27-1/2	698
5.5	90-1/4	2292	74-7/8	1902	34-1/4	870
6.1	39-1/16	992	20-1/2	521	17	432
6.2	49-9/16	1259	31	787	27-1/2	699
6.3	70-9/16	1792	52	1321	48-1/2	1232
6.4	91-9/16	2326	73	1854	69-1/2	1765
8.2	53-3/4	1365	32-11/16	830	29-3/16	741
8.3	60-3/4	1543	39-11/16	1008	36-3/16	919
8.4	68-3/4	1746	47-5/16	1202	43-13/16	1113

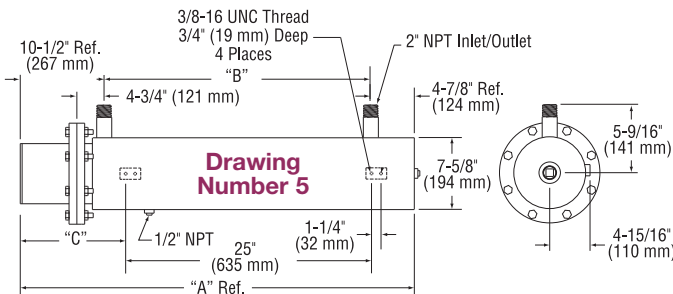
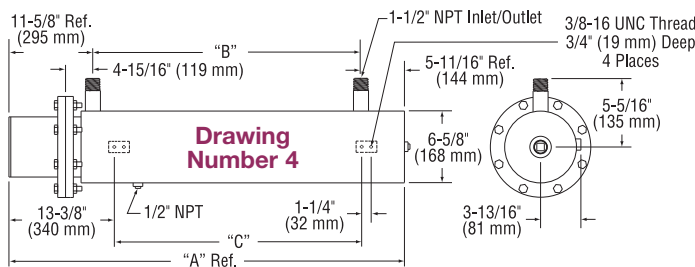

Note: Circulation heater mounting lug design and location in the assembly drawings shown are standard. Designs can be modified to fit customer installation. Consult Tempco with your requirements.

Ordering Information

See Page 11-69 for complete Ordering Information.

CONTINUED

Circulation Heaters

Standard (Non-Stock) Circulation Heaters

Continued from previous page...

23 watts/in² (3.6 watts/cm²) — Typical Applications: Forced Air & Gases • Caustic Solutions • Degreasing Solutions

Nominal Pipe Size	Dimensional Drawing Number	KW	Part Number				Approximate Net Weight		
			120V	240V-1Ph (C*)	240V-3Ph (C*)	480V-1Ph (C*)	480V-3Ph (C*)	lbs	kgs
10"-150lb 27 elements	10.1	60	—	—	CHF01686 (3)	—	CHF01687 (3)	440	200
	10.2	75	—	—	CHF01688 (9)	—	CHF01689 (3)	485	220
12"-150lb 36 elements	12.1	80	—	—	—	—	CHF01690 (3)	550	250
	12.2	100	—	—	—	—	CHF01691 (3)	595	270
14"-150lb 45 elements	14.1	100	—	—	—	—	CHF01692 (3)	675	307
	14.2	125	—	—	—	—	CHF01693 (5)	771	350

(C*) = Number of Branch Circuits per heater

NOTE: Nominal Pipe Size 8" and larger are 20 watts/in² (3.1 watts/cm²)

Dimensional Drawing Number

Drawing Number	"A"		"B"		"C"	
	in	mm	in	mm	in	mm
10.1	74	1880	60-1/4	1531	66	1676
10.2	81-1/2	2070	67-3/4	1721	73-1/2	1867
12.1	74-1/4	1886	60	1524	66-1/8	1680
12.2	81-3/4	2076	67-1/2	1715	73-5/8	1870
14.1	74-5/8	1895	59-3/8	1508	66-1/4	1683
14.2	82-1/8	2086	66-7/8	1699	73-3/4	1873



Note: Circulation heater mounting lug design and location in the assembly drawings shown are standard. Designs can be modified to fit customer installation. Consult Tempco with your requirements.

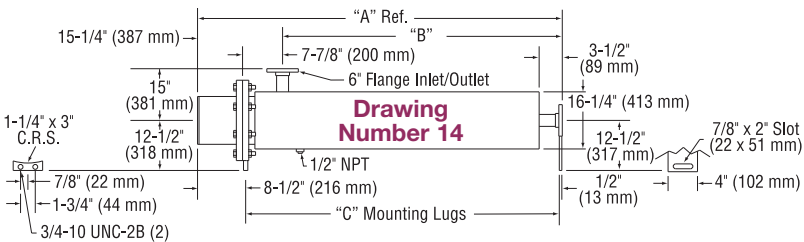
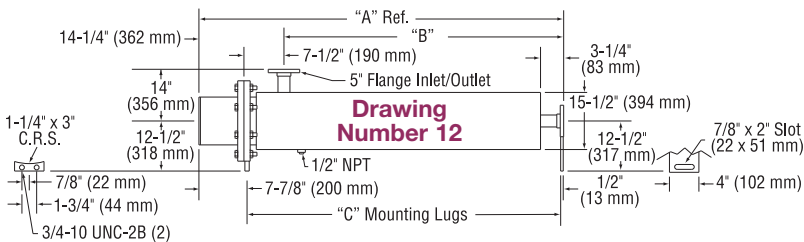
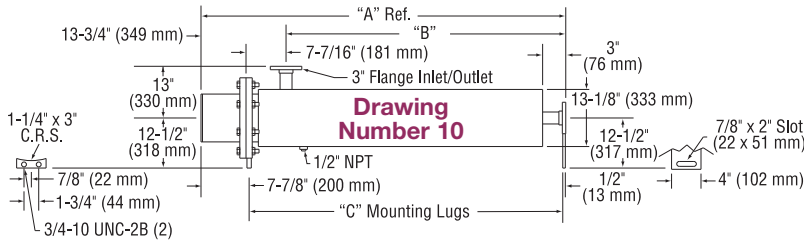

Ordering Information

See Page 11-69 for complete Ordering Information.



Standard (Non-Stock) Circulation Heaters

48 watts/in² (7.5 watts/cm²) — Typical Applications: Process Water

- * 304 Stainless Steel Screw Plug and Steel 150-lb Flanged Heater Sizes
- * Steel Tank

- * Incoloy®800 Sheath Heating Elements
- * NEMA 1 Terminal Housing

Nominal Pipe Size	Dimensional Drawing Number	KW	Part Number					Approximate Net Weight	
			120V	240V-1Ph (C*)	240V-3Ph (C*)	480V-1Ph (C*)	480V-3Ph (C*)	lbs	kgs
2½" NPT 3 elements	2.1	6	—	CHF01694 (1)	CHF01695 (1)	CHF01696 (1)	CHF01697 (1)	28	13
	2.1	7.5	—	CHF01698 (1)	CHF01699 (1)	CHF01700 (1)	CHF01701 (1)	29	13
	2.1	9	—	CHF01702 (1)	CHF01703 (1)	CHF01704 (1)	CHF01705 (1)	30	14
	2.2	12	—	—	CHF01706 (1)	CHF01707 (1)	CHF01708 (1)	37	17
	2.3	15	—	—	CHF01709 (1)	CHF01710 (1)	CHF01711 (1)	45	20
	2.3	18	—	—	CHF01712 (1)	CHF01713 (1)	CHF01714 (1)	46	21
3"-150lb 3 elements	3.1	6	—	CHF01715 (1)	CHF01716 (1)	CHF01717 (1)	CHF01718 (1)	53	24
	3.1	7.5	—	CHF01719 (1)	CHF01720 (1)	CHF01721 (1)	CHF01722 (1)	53	24
	3.2	9	—	CHF01723 (1)	CHF01724 (1)	CHF01725 (1)	CHF01726 (1)	61	28
	3.2	12	—	—	CHF01727 (1)	CHF01728 (1)	CHF01729 (1)	62	28
	3.3	15	—	—	CHF01730 (1)	CHF01731 (1)	CHF01732 (1)	74	34
	3.3	18	—	—	CHF01733 (1)	CHF01734 (1)	CHF01735 (1)	76	34

(C*) = Number of Branch Circuits per heater

Dimensional Drawing Number

Drawing Number	"A"		"B"		"C"	
	in	mm	in	mm	in	mm
2.1	32-11/16	830	22-1/2	572	16-1/2	419
2.2	42-11/16	1084	32-1/2	826	26-1/2	673
2.3	55-3/16	1402	45	1143	39	991
3.1	34-5/8	879	22-1/2	572	16-1/2	419
3.2	44-5/8	1133	32-1/2	826	26-1/2	673
3.3	57-1/8	1451	45	1143	39	991



Note: Circulation heater mounting lug design and location in the assembly drawings shown are standard. Designs can be modified to fit customer installation. Consult Tempco with your requirements.

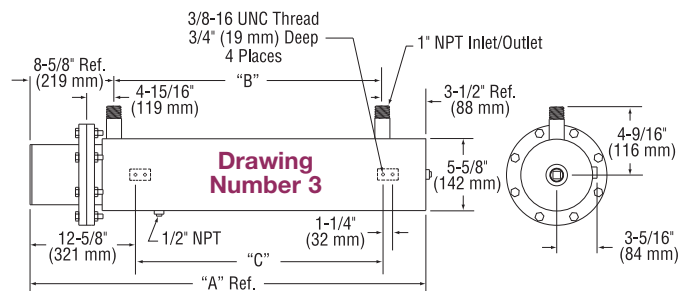
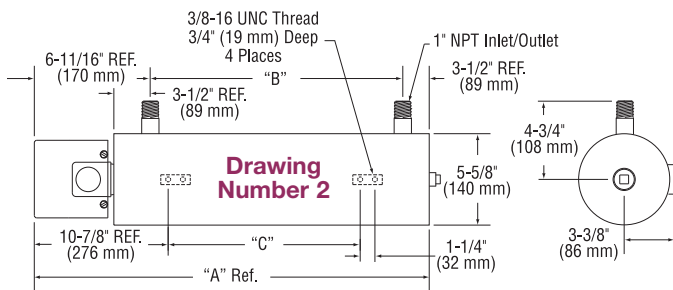

Circulation heater with optional externally mounted thermostat.

Ordering Information

See Page 11-69 for complete Ordering Information.

CONTINUED →

Standard (Non-Stock) Circulation Heaters

Continued from previous page...

48 watts/in² (7.5 watts/cm²) — Typical Applications: Process Water

Nominal Pipe Size	Dimensional Drawing Number	KW	Part Number					Approximate Net Weight	
			120V	240V-1Ph (C*)	240V-3Ph (C*)	480V-1Ph (C*)	480V-3Ph (C*)	lbs	kgs
4"-150lb 6 elements	4.1	9	—	CHF01736 (1)	CHF01737 (1)	CHF01738 (1)	CHF01739 (1)	76	34
	4.1	12	—	CHF01740 (2)	CHF01741 (1)	CHF01742 (1)	CHF01743 (1)	78	35
	4.1	15	—	CHF01744 (2)	CHF01745 (1)	CHF01746 (1)	CHF01747 (1)	79	36
	4.2	18	—	CHF01748 (2)	CHF01749 (1)	CHF01750 (1)	CHF01751 (1)	91	41
	4.2	24	—	CHF01752 (2)	CHF01753 (2)	CHF01754 (2)	CHF01755 (1)	94	43
	4.3	30	—	—	CHF01756 (2)	CHF01757 (2)	CHF01758 (1)	117	53
5"-150lb 6 elements	4.3	36	—	—	CHF01759 (2)	CHF01760 (2)	CHF01761 (1)	120	54
	5.1	24	—	CHF01762 (2)	CHF01763 (2)	CHF01764 (2)	CHF01765 (1)	117	53
	5.2	30	—	—	CHF01766 (2)	CHF01767 (2)	CHF01768 (1)	128	58
5"-150lb 9 elements	5.3	36	—	—	CHF01769 (2)	CHF01770 (2)	CHF01771 (1)	146	66
	5.1	36	—	—	CHF01772 (3)	CHF01773 (3)	CHF01774 (1)	123	56
	5.2	45	—	—	CHF01775 (3)	CHF01776 (3)	CHF01777 (3)	135	61
6"-150lb 12 elements	5.3	54	—	—	CHF01778 (3)	CHF01779 (3)	CHF01780 (3)	154	70
	6.1	18	—	CHF01781 (2)	CHF01782 (1)	CHF01783 (1)	CHF01784 (1)	124	56
	6.1	24	—	CHF01785 (2)	CHF01786 (2)	CHF01787 (2)	CHF01788 (1)	127	58
	6.1	30	—	CHF01789 (3)	CHF01790 (2)	CHF01791 (2)	CHF01792 (1)	129	59
	6.2	36	—	CHF01793 (3)	CHF01794 (2)	CHF01795 (2)	CHF01796 (1)	152	69
	6.2	48	—	—	CHF01797 (4)	CHF01798 (3)	CHF01799 (2)	157	71
	6.3	60	—	—	CHF01800 (4)	CHF01801 (3)	CHF01802 (2)	197	89
6"-150lb 15 elements	6.3	72	—	—	CHF01803 (4)	—	CHF01804 (2)	202	92
	6.1	23	—	CHF01805 (3)	CHF01806 (5)	CHF01807 (1)	CHF01808 (1)	126	57
	6.1	30	—	CHF01809 (3)	CHF01810 (5)	CHF01811 (3)	CHF01812 (1)	130	59
	6.1	38	—	CHF01813 (5)	CHF01814 (5)	CHF01815 (3)	CHF01816 (1)	132	60
	6.2	45	—	CHF01817 (5)	CHF01818 (5)	CHF01819 (3)	CHF01820 (5)	156	71
	6.2	60	—	—	CHF01821 (5)	CHF01822 (3)	CHF01823 (5)	163	74
	6.3	75	—	—	CHF01824 (5)	CHF01825 (5)	CHF01826 (5)	204	93
8"-150lb 18 elements	6.3	90	—	—	CHF01827 (5)	—	CHF01828 (5)	211	96
	8.2	50	—	—	CHF01829 (3)	CHF01830 (3)	CHF01831 (2)	234	106
	8.3	75	—	—	CHF01832 (6)	—	CHF01833 (2)	264	120
	8.4	100	—	—	CHF01834 (6)	—	CHF01835 (3)	293	133
	8.5	125	—	—	CHF01836 (6)	—	CHF01837 (6)	327	148
	8.6	150	—	—	—	—	CHF01838 (6)	360	163
	8.7	175	—	—	—	—	CHF01839 (6)	395	179
8"-150lb 24 elements	8.7	200	—	—	—	—	CHF01840 (6)	405	184
	8.2	67	—	—	CHF01841 (4)	CHF01842 (3)	CHF01843 (2)	243	110
	8.3	100	—	—	CHF01844 (8)	—	CHF01845 (4)	277	126
	8.4	133	—	—	CHF01846 (8)	—	CHF01847 (4)	308	140
	8.5	167	—	—	CHF01848 (8)	—	CHF01849 (8)	346	157
	8.6	200	—	—	—	—	CHF01850 (8)	382	173
	8.7	233	—	—	—	—	CHF01851 (8)	420	191
10"-150lb 27 elements	8.7	267	—	—	—	—	CHF01852 (8)	433	196
	10.3	225	—	—	—	—	CHF01853 (9)	539	244
12"-150lb 36 elements	10.5	262	—	—	—	—	CHF01854 (9)	615	279
	12.3	300	—	—	—	—	CHF01855 (12)	694	315
14"-150lb 45 elements	12.5	350	—	—	—	—	CHF01856 (12)	782	355
	14.2	315	—	—	—	—	CHF01857 (15)	771	350
	14.3	375	—	—	—	—	CHF01858 (15)	827	375

(C*) = Number of Branch Circuits per heater

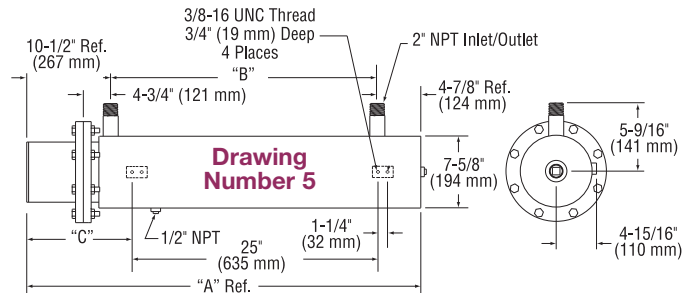
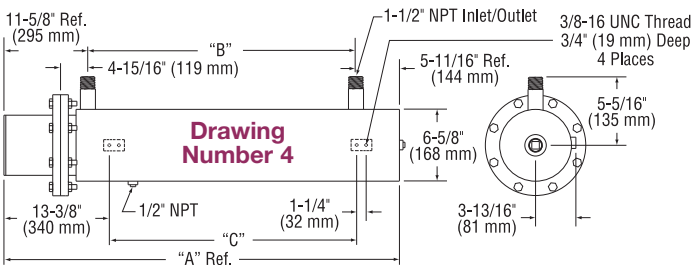

Standard (Non-Stock) Circulation Heaters

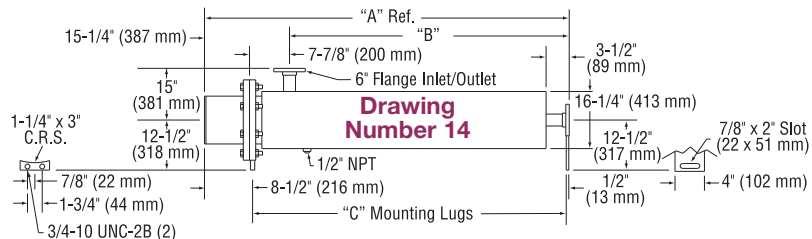
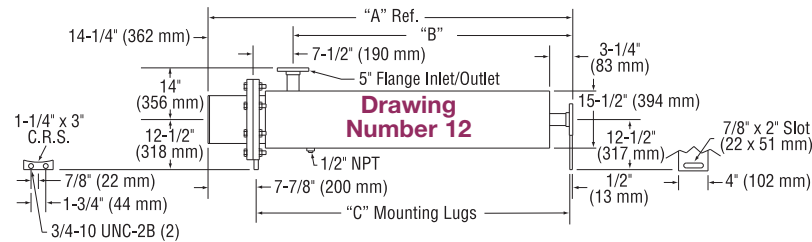
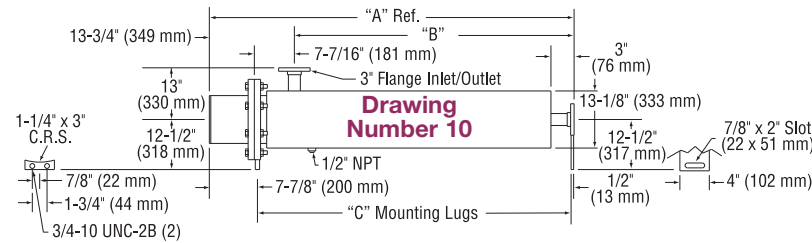
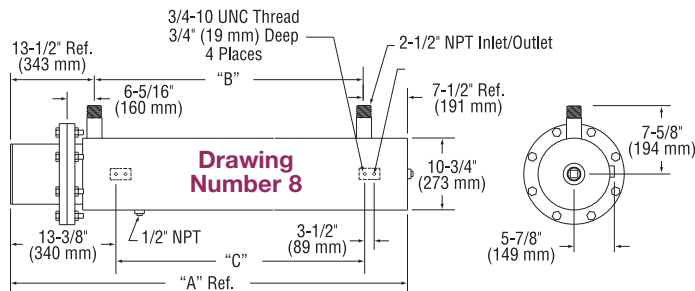
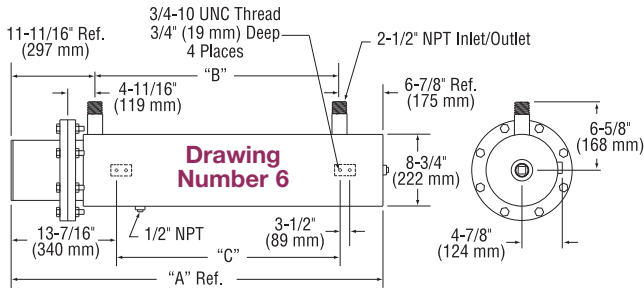

Dimensional Drawing Number

Drawing Number	"A"		"B"		"C"	
	in	mm	in	mm	in	mm
4.1	37-13/16	960	20-1/2	521	17	432
4.2	48-5/16	1227	31	787	27-1/2	699
4.3	69-5/16	1761	52	1321	48-1/2	1232
5.1	45-3/8	1153	30	762	11-1/2	292
5.2	52-3/8	1330	37	940	15-1/4	387
5.3	63-7/8	1622	48-1/2	1232	21	533
6.1	39-1/16	992	20-1/2	521	17	432
6.2	49-9/16	1259	31	787	27-1/2	699
6.3	70-9/16	1792	52	1321	48-1/2	1232
8.2	53-3/4	1365	32-11/16	830	29-3/16	741
8.3	60-3/4	1543	39-11/16	1008	36-3/16	919
8.4	68-3/4	1746	47-5/16	1202	43-13/16	1113
8.5	77-7/8	1978	56-13/16	1443	53-5/16	1354
8.6	86-7/8	2207	65-13/16	1672	62-5/16	1583
8.7	96-7/8	2461	75-13/16	1926	72-5/16	1837
10.3	89	2261	75-1/4	1911	81	2057
10.5	104	2642	90-1/4	2292	96	2438
12.3	89-1/4	2267	75	1905	81-1/8	2061
12.5	104-1/4	2648	90	2286	96-1/8	2442
14.2	82-1/8	2086	66-7/8	1699	73-3/4	1873
14.3	89-5/8	2276	74-3/8	1889	81-1/4	2064



Note: Circulation heater mounting lug design and location in the assembly drawings shown are standard. Designs can be modified to fit customer installation. Consult Tempco with your requirements.

Ordering Information

See Page 11-69 for complete Ordering Information.



Circulation Heaters

Standard (Non-Stock) Circulation Heaters

60 watts/in² (9.3 watts/cm²) — Typical Applications: Clean Water

- * Brass Screw Plug and Steel 150-lb Flanged Heater Sizes
- * Steel Tank

- * Copper Sheath Heating Elements
- * NEMA 1 Terminal Housing

Nominal Pipe Size	Dimensional Drawing Number	KW	Part Number					Approximate Net Weight	
			120V	240V-1Ph (C*)	240V-3Ph (C*)	480V-1Ph (C*)	480V-3Ph (C*)	lbs	kg
1¼" NPT 2 elements	1.1	3	CHF01859	CHF01860 (1)	—	—	—	14	6
	1.1	4	—	CHF01861 (1)	—	—	—	14	6
	1.2	5	—	CHF01862 (1)	—	—	—	17	8
	1.2	6	—	CHF01863 (1)	—	—	—	18	8
2½" NPT 3 elements	2.1	6	—	CHF01864 (1)	CHF01865 (1)	CHF01866 (1)	CHF01867 (1)	26	12
	2.1	7.5	—	CHF01868 (1)	CHF01869 (1)	CHF01870 (1)	CHF01871 (1)	26	12
	2.1	9	—	CHF01872 (1)	CHF01873 (1)	CHF01874 (1)	CHF01875 (1)	27	12
	2.2	12	—	—	CHF01877 (1)	CHF01878 (1)	CHF01879 (1)	34	15
	2.2	15	—	—	CHF01881 (1)	CHF01882 (1)	CHF01883 (1)	35	16
	2.3	18	—	—	CHF01885 (1)	CHF01886 (1)	CHF01887 (1)	43	20
3"-150lb 3 elements	3.1	6	—	CHF01888 (1)	CHF01889 (1)	CHF01890 (1)	CHF01891 (1)	52	24
	3.1	9	—	CHF01892 (1)	CHF01893 (1)	CHF01894 (1)	CHF01895 (1)	53	24
	3.2	12	—	—	CHF01896 (1)	CHF01897 (1)	CHF01898 (1)	61	28
	3.2	15	—	—	CHF01899 (1)	CHF01900 (1)	CHF01901 (1)	67	30
	3.3	18	—	—	CHF01902 (1)	CHF01903 (1)	CHF01904 (1)	74	34
4"-150lb 6 elements	4.1	12	—	CHF01905 (2)	CHF01906 (1)	CHF01907 (1)	CHF01908 (1)	77	35
	4.1	18	—	CHF01909 (2)	CHF01910 (1)	CHF01911 (1)	CHF01912 (1)	79	36
	4.2	24	—	CHF01913 (2)	CHF01914 (2)	CHF01915 (2)	CHF01916 (1)	92	42
	4.2	30	—	—	CHF01917 (2)	CHF01918 (2)	CHF01919 (1)	94	43
	4.3	36	—	—	CHF01920 (2)	CHF01921 (2)	CHF01922 (1)	117	53
	4.3	50	—	—	—	—	CHF01923 (2)	121	55
	4.4	60	—	—	—	—	CHF01924 (2)	145	66
5"-150lb 6 elements	5.1	24	—	CHF01925 (2)	CHF01926 (2)	CHF01927 (2)	CHF01928 (1)	115	52
	5.1	30	—	—	CHF01929 (2)	CHF01930 (2)	CHF01931 (1)	117	53
	5.2	36	—	—	CHF01932 (2)	CHF01933 (2)	CHF01934 (1)	128	58
	5.3	50	—	—	—	—	CHF01935 (2)	167	76
	5.4	60	—	—	—	—	CHF01936 (2)	196	89
5"-150lb 9 elements	5.1	36	—	—	CHF01937 (3)	CHF01938 (3)	CHF01939 (3)	120	54
	5.1	45	—	—	CHF01940 (3)	CHF01941 (3)	CHF01942 (3)	122	55
	5.2	54	—	—	CHF01943 (3)	CHF01944 (3)	CHF01945 (3)	134	61
	5.3	75	—	—	—	—	CHF01946 (3)	176	80
	5.4	90	—	—	—	—	CHF01947 (3)	197	89
6"-150lb 12 elements	6.1	24	—	CHF01948 (2)	CHF01949 (2)	CHF01950 (2)	CHF01951 (1)	125	57
	6.1	36	—	CHF01952 (3)	CHF01953 (2)	CHF01954 (2)	CHF01955 (1)	129	59
	6.2	48	—	—	CHF01956 (4)	CHF01957 (3)	CHF01958 (2)	153	69
	6.2	60	—	—	CHF01959 (4)	CHF01960 (3)	CHF01961 (2)	157	71
	6.3	72	—	—	CHF01962 (4)	—	CHF01963 (2)	196	89
	6.3	100	—	—	—	—	CHF01964 (2)	204	93
	6.4	120	—	—	—	—	CHF01965 (4)	246	112
6"-150lb 15 elements	6.1	30	—	CHF01966 (3)	CHF01967 (5)	CHF01968 (3)	CHF01969 (1)	128	58
	6.1	45	—	CHF01970 (5)	CHF01971 (5)	CHF01972 (3)	CHF01973 (5)	133	60
	6.2	60	—	—	CHF01974 (5)	CHF01975 (3)	CHF01976 (5)	158	72
	6.2	75	—	—	CHF01977 (5)	CHF01978 (5)	CHF01979 (5)	163	74
	6.3	90	—	—	CHF01980 (5)	—	CHF01981 (5)	202	92
	6.3	125	—	—	—	—	CHF01982 (5)	213	97
	6.4	150	—	—	—	—	CHF01983 (5)	257	117
8"-150lb 18 elements	8.1	50	—	—	CHF01984 (3)	CHF01985 (3)	CHF01986 (2)	210	95
	8.2	75	—	—	CHF01987 (6)	—	CHF01988 (2)	238	108
	8.3	100	—	—	CHF01989 (6)	—	CHF01990 (3)	266	121
	8.4	125	—	—	CHF01991 (6)	—	CHF01992 (6)	294	133
	8.5	150	—	—	—	—	CHF01993 (6)	326	148
	8.6	175	—	—	—	—	CHF01994 (6)	358	162
	8.7	200	—	—	—	—	CHF01995 (6)	391	177

(C*) = Number of Branch Circuits per heater

Standard (Non-Stock) Circulation Heaters

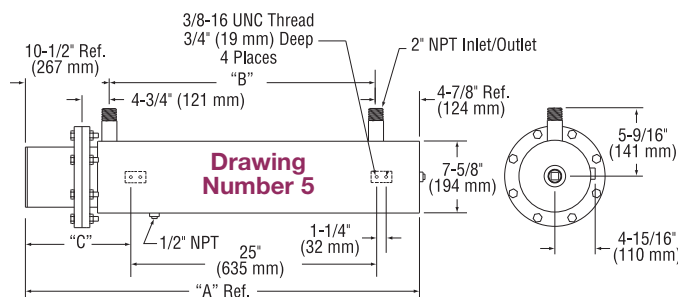
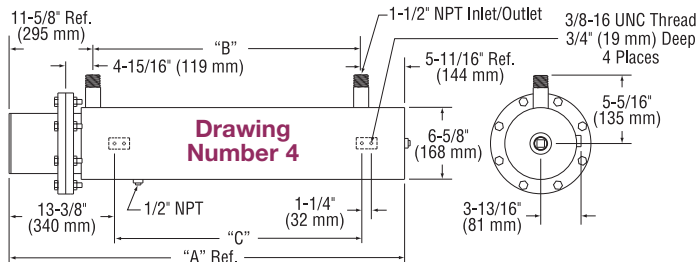
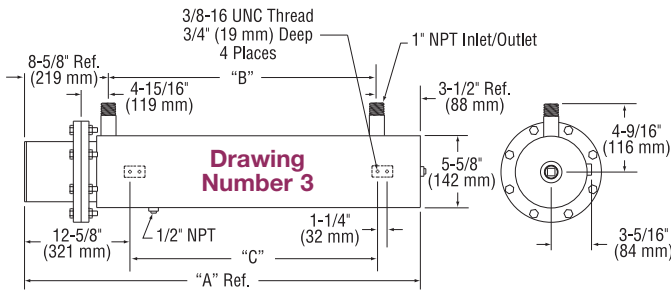
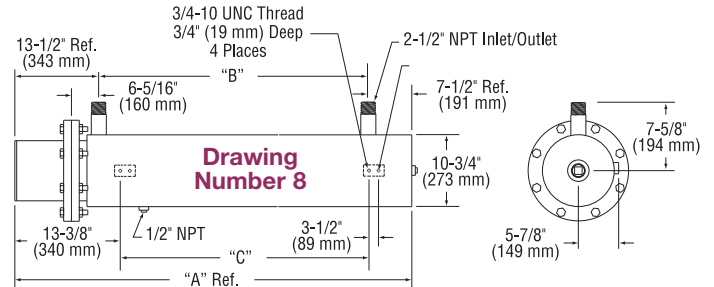
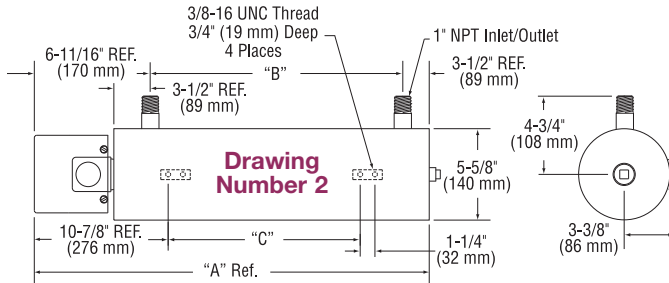
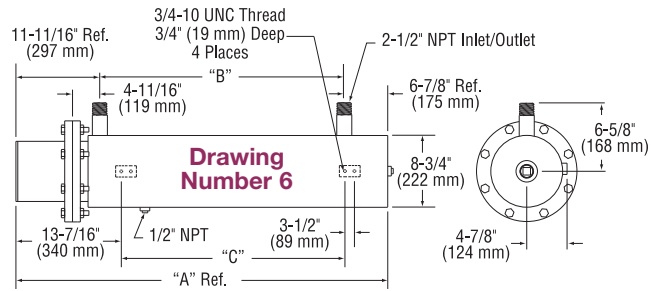
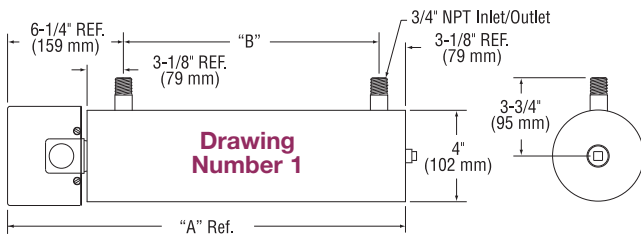

Dimensional Drawing Number

Drawing Number	"A"		"B"		"C"	
	in	mm	in	mm	in	mm
1.1	24-3/8	619	15	381		
1.2	32-3/8	822	23	584		
2.1	32-11/16	830	22-1/2	572	16-1/2	419
2.2	42-11/16	1084	32-1/2	826	26-1/2	673
2.3	55-3/16	1402	45	1143	39	991
3.1	34-5/8	879	22-1/2	572	16-1/2	419
3.2	44-5/8	1133	32-1/2	826	26-1/2	673
3.3	57-1/8	1451	45	1143	39	991
4.1	37-13/16	960	20-1/2	521	17	432
4.2	48-5/16	1227	31	787	27-1/2	699
4.3	69-5/16	1761	52	1321	48-1/2	1232
4.4	90-5/16	2294	73	1854	69-1/2	1765
5.1	45-3/8	1153	30	762	11-1/2	292
5.2	52-3/8	1330	37	940	15-1/4	387
5.3	63-7/8	1622	48-1/2	1232	21	533
5.4	77-1/4	1962	61-7/8	1572	27-1/2	698
6.1	39-1/16	992	20-1/2	521	17	432
6.2	49-9/16	1259	31	787	27-1/2	699
6.3	70-9/16	1792	52	1321	48-1/2	1232
6.4	91-9/16	2326	73	1854	69-1/2	1765
8.1	46	1168	24-11/16	627	21-3/16	538
8.2	53-3/4	1365	32-11/16	830	29-3/16	741
8.3	60-3/4	1543	39-11/16	1008	36-3/16	919
8.4	68-3/4	1746	47-5/16	1202	43-13/16	1113
8.5	77-7/8	1978	56-13/16	1443	53-5/16	1354
8.6	86-7/8	2207	65-13/16	1672	62-5/16	1583
8.7	96-7/8	2461	75-13/16	1926	72-5/16	1837



Note: Circulation heater mounting lug design and location in the assembly drawings shown are standard. Designs can be modified to fit customer installation. Consult Tempco with your requirements.

Ordering Information

See Page 11-69 for complete Ordering Information.

Standard (Non-Stock) Circulation Heaters

60 watts/in² (9.3 watts/cm²) — Typical Applications: Deionized Water • Demineralized Water

- * 316 Stainless Steel Screw Plug and 316 Stainless Steel 150-lb Flanged Heater Sizes
- * 316 Stainless Steel Tank

- * 316 Stainless Steel Sheath Heating Elements
- * NEMA 1 Terminal Housing

Nominal Pipe Size	Dimensional Drawing Number	KW	Part Number					Approximate Net Weight	
			120V	240V-1Ph (C*)	240V-3Ph (C*)	480V-1Ph (C*)	480V-3Ph (C*)	lbs	kgs
2½" NPT 3 elements	2.1	6	—	CHF01996 (1)	CHF01997 (1)	CHF01998 (1)	CHF01999 (1)	28	13
	2.1	7.5	—	CHF02000 (1)	CHF02001 (1)	CHF02002 (1)	CHF02003 (1)	28	13
	2.1	9	—	CHF02004 (1)	CHF02005 (1)	CHF02006 (1)	CHF02007 (1)	29	13
	2.2	12	—	—	CHF02009 (1)	CHF02010 (1)	CHF02011 (1)	36	16
	2.2	15	—	—	CHF02013 (1)	CHF02014 (1)	CHF02015 (1)	37	17
	2.3	18	—	—	CHF02017 (1)	CHF02018 (1)	CHF02019 (1)	38	17
	4"-150lb 6 elements	4.1	12	—	—	CHF02021 (1)	CHF02022 (1)	CHF02023 (1)	77
4.1		18	—	—	CHF02025 (1)	CHF02026 (1)	CHF02027 (1)	79	36
4.2		24	—	—	CHF02029 (2)	CHF02030 (2)	CHF02031 (1)	92	42
4.2		30	—	—	CHF02032 (2)	CHF02033 (2)	CHF02034 (1)	94	42
4.3		36	—	—	CHF02035 (2)	CHF02036 (2)	CHF02037 (1)	117	53
4.3		50	—	—	—	—	CHF02038 (2)	121	55
4.4		60	—	—	—	—	CHF02039 (2)	145	66
6"-150lb 12 elements	6.1	24	—	CHF02040 (3)	CHF02041 (2)	CHF02042 (2)	CHF02043 (1)	126	57
	6.1	36	—	CHF02044 (3)	CHF02045 (2)	CHF02046 (2)	CHF02047 (1)	130	59
	6.2	48	—	—	CHF02048 (4)	CHF02049 (3)	CHF02050 (2)	153	69
	6.2	60	—	—	CHF02051 (4)	CHF02052 (3)	CHF02053 (2)	157	71
	6.3	72	—	—	CHF02054 (4)	—	CHF02055 (2)	196	89
	6.3	100	—	—	—	—	CHF02056 (4)	205	93
	6.4	120	—	—	—	—	CHF02057 (4)	246	112
6"-150lb 15 elements	6.1	30	—	CHF02058 (3)	CHF02059 (5)	CHF02060 (3)	CHF02061 (1)	128	58
	6.1	45	—	CHF02062 (5)	CHF02063 (5)	CHF02064 (3)	CHF02065 (5)	133	60
	6.2	60	—	—	CHF02066 (5)	CHF02067 (3)	CHF02068 (5)	158	72
	6.2	75	—	—	CHF02069 (5)	CHF02070 (5)	CHF02071 (5)	163	74
	6.3	90	—	—	CHF02072 (5)	—	CHF02073 (5)	202	92
	6.3	125	—	—	—	—	CHF02074 (5)	213	97
	6.4	150	—	—	—	—	CHF02075 (5)	257	117

(C*) = Number of Branch Circuits per heater



Standard (Non-Stock) Circulation Heaters

Dimensional Drawing Number

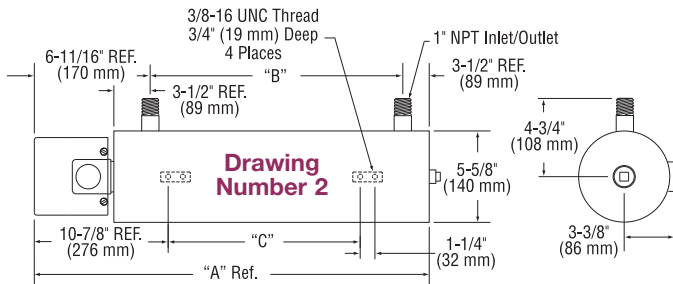

Drawing Number	"A"		"B"		"C"	
	in	mm	in	mm	in	mm
2.1	32-11/16	830	22-1/2	572	16-1/2	419
2.2	42-11/16	1084	32-1/2	826	26-1/2	673
2.3	55-3/16	1402	45	1143	39	991
4.1	37-13/16	960	20-1/2	521	17	432
4.2	48-5/16	1227	31	787	27-1/2	699
4.3	69-5/16	1761	52	1321	48-1/2	1232
4.4	90-5/16	2294	73	1854	69-1/2	1765
6.1	39-1/16	992	20-1/2	521	17	432
6.2	49-9/16	1259	31	787	27-1/2	699
6.3	70-9/16	1792	52	1321	48-1/2	1232
6.4	91-9/16	2326	73	1854	69-1/2	1765



Note: Circulation heater mounting lug design and location in the assembly drawings shown are standard. Designs can be modified to fit customer installation. Consult Tempco with your requirements.

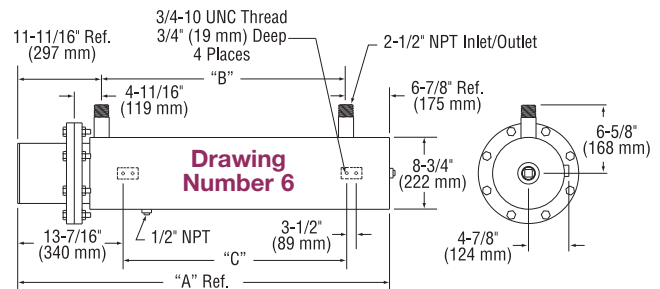
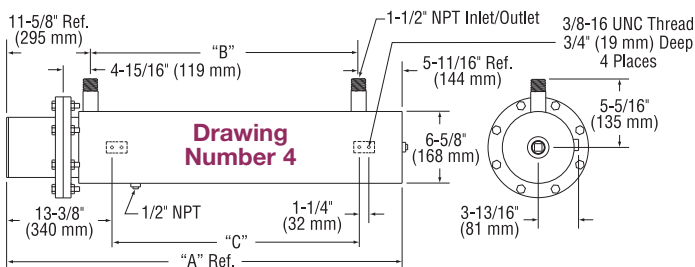

Ordering Information

Catalog Heaters

Order by Part Number for catalog heaters listed on pages 11-51 through 11-68.

Standard lead time is 4-5 weeks.

Custom Engineered/Manufactured Heaters

For sizes and ratings not listed, **TEMPCO** will design and manufacture a Circulation Heater to meet your requirements. **Please Specify** the following:

- Application, including operating temperature/pressure
- Wattage, Voltage and Phase
- Screw Plug or Flange Size and Material
- Element Sheath Material
- Element Watt Density
- Element Immersion Length
- Electrical Enclosure Type
- Thermostat— if required
- Vessel Material
- Additional Insulation
- Flow Control Baffles
- Other Optional Features

WARNING: Cancer and Reproductive Harm - www.P65Warnings.ca.gov.

Mightybooster™ Circulation Heater — Point of Use

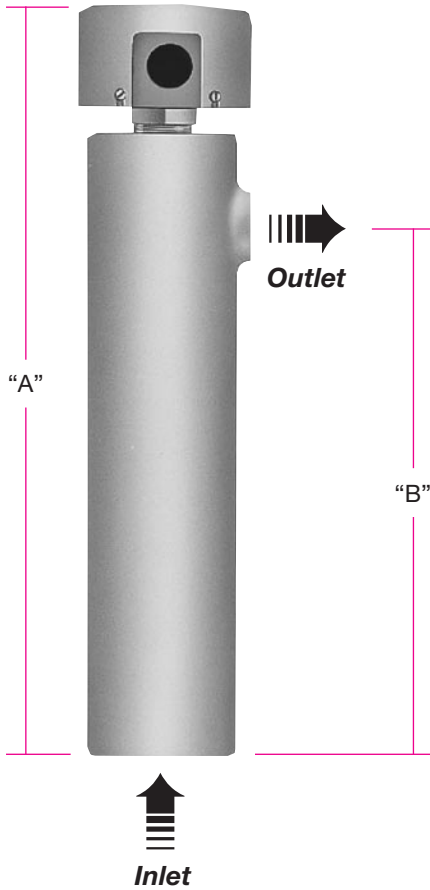

Design Features

- * Integral 60°F (15°C) to 180°F (82°C) Thermostat
- * NEMA 1 Terminal Housing
- * Insulated Carbon Steel or Bronze Vessel
- * 1" NPT Inlet and Outlet
- * Copper Sheath Heating Elements and Brass Screw Plug
- * Watt Density of 60 watts/in² (9.3 watts/cm²)

Typical Heating Application: Clean Water • Aqueous Solutions

Vessel Material	KW	"A" OAL		"B" Inlet-Outlet		Part Number 120/240V	Approximate Net Weight	
		in	mm	in	mm		lbs	kgs
Carbon Steel	1.5	18	457	12 ³ / ₈	314	CHF02097	8	3.6
	2.0	18	457	12 ³ / ₈	314	CHF02098	8	3.6
	2.5	22	559	16 ³ / ₈	416	CHF02099	11	5.0
	3.0	22	559	16 ³ / ₈	416	CHF02100	11	5.0
Bronze	1.5	18	457	12 ³ / ₈	314	CHF02101	12.5	5.7
	2.0	18	457	12 ³ / ₈	314	CHF02102	12.5	5.7
	2.5	22	559	16 ³ / ₈	416	CHF02103	14.5	6.6
	3.0	22	559	16 ³ / ₈	416	CHF02104	14.5	6.6

Design Features

- * Integral 150°F (65°C) to 560°F (300°C) Thermostat
- * NEMA 1 Terminal Housing
- * Insulated Carbon Steel Vessel
- * 1" NPT Inlet and Outlet
- * Steel Sheath Heating Elements and Steel Screw Plug
- * Watt Density of 23 watts/in² (3.6 watts/cm²)

Typical Heating Application: Lubricating Oils

Vessel Material	KW	"A" OAL		"B" Inlet-Outlet		Part Number 120/240V	Approximate Net Weight	
		in	mm	in	mm		lbs	kgs
Carbon Steel	0.5	22	559	16 ³ / ₈	416	CHF02105	11	5.0
	0.75	22	559	16 ³ / ₈	416	CHF02106	11	5.0
	1.0	22	559	16 ³ / ₈	416	CHF02107	11	5.0

Ordering Information

Catalog Heaters

Order by Part Number for catalog heaters listed above.
Standard lead time is 3-4 weeks.

Custom Engineered/Manufactured Heaters

For ratings not listed, **TEMPCO** will design and manufacture a Mightybooster Heater to meet your requirements.

Please Specify the following:

- | | |
|--|--|
| <input type="checkbox"/> Application, including operating temperature/pressure | <input type="checkbox"/> Element Immersion Length |
| <input type="checkbox"/> Wattage and Voltage | <input type="checkbox"/> Electrical Enclosure Type |
| <input type="checkbox"/> Screw Plug Material | <input type="checkbox"/> Thermostat — if required |
| <input type="checkbox"/> Element Sheath Material | <input type="checkbox"/> Vessel Material |
| <input type="checkbox"/> Element Watt Density | <input type="checkbox"/> Additional Insulation |
| | <input type="checkbox"/> Other Optional Features |

WARNING: Cancer and Reproductive Harm - www.P65Warnings.ca.gov.

Process Circulation Heating Systems

TEMPCO Circulation Systems include a circulation heater and power control panel skid mounted in a compact package to use minimal floor space. Heater vessel is carbon steel and can be vertically or horizontally mounted.

The pre-wired panel contains a process temperature control and a manual reset over-temperature control. The Zero Cross SCR power controller provides proportional power to the heater load for precise temperature control.

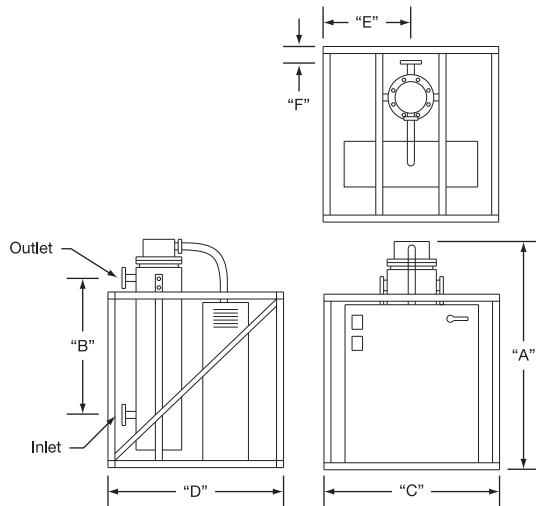

Design Features

- * 150-lb Flanged Heater Sizes
- * Steel Sheath Heating Elements
- * NEMA 1 Terminal Housing
- * Watt Density of 15 watts/in² (2.3 watts/cm²)
- * NEMA 12 Control Panel with Main Fused Disconnect, Door Interlock and FM High Limit Cutout



Standard (Non-Stock) Vertically Mounted Process Circulation Heating Systems

Typical Heating Applications: Medium Weight Oils • Heat Transfer Oils

KW	Heater Flange Size	In-Out Pipe Size	"A"		"B"		"C"		"D"		"E"		"F"		Part Number	
			in	mm	in	mm	in	mm	in	mm	in	mm	in	mm	240V-3Ph	480V-3Ph
10	5"	2"	46	1168	25	635	39	991	13	330	8	203	43	1092	CHS02076	CHS02077
15	5"	2"	58	1473	37	940	39	991	13	330	8	203	57	1448	CHS02078	CHS02079
20	5"	2"	71	1803	50	1270	39	991	13	330	8	203	70	1778	CHS02080	CHS02081
25	5"	2"	83	2102	62	1575	39	991	13	330	8	203	82	2083	CHS02082	CHS02083
30	8"	2½"	52	1321	25	635	42	1067	14	356	13	330	45	1143	CHS02084	CHS02085
40	8"	2½"	65	1651	37	940	42	1067	14	356	13	330	59	1499	CHS02086	CHS02087
55	8"	2½"	77	1956	50	1270	42	1067	14	356	13	330	72	1829	CHS02088	CHS02089
70	8"	2½"	90	2286	62	1575	42	1067	14	356	13	330	84	2134	CHS02090	CHS02091
90	10"	4"	108	2743	75	1905	44	1118	19	483	14	356	102	2591	CHS02092	CHS02093
110	12"	5"	96	2438	62	1575	46	1168	19	483	15	381	89	2261	—	CHS02094
150	14"	6"	97	2464	62	1575	48	1219	19	483	16	406	89	2261	—	CHS02095
180	14"	6"	110	2794	75	1905	48	1219	19	483	16	406	102	2591	—	CHS02096

NOTE: Dimensions are approximate

Ordering Information

Catalog Heaters

Order by Part Number for catalog heaters.

Standard lead time is 6-7 weeks.

Custom Engineered/Manufactured Heaters

For sizes and ratings not listed, **TEMPCO** will design and manufacture a Circulation System to meet your requirements. **Please Specify** the following:

- Maximum temperature rise and operating pressure
- Inlet-Outlet size and type
- Vertical or horizontal mounting
- Element sheath material (Steel, Incoloy® or Copper)
- Vessel material (carbon steel or stainless steel)
- Element Watt density
- Wattage (up to 600KW), Voltage, Phase

WARNING: Cancer and Reproductive Harm - www.P65Warnings.ca.gov.



Floor-Mount, Double-Door Panel

This 2-zone, SCR power control unit with 8 output heater circuits in a NEMA 12 enclosure is used to control trim heaters in a paper pulp mill.

Deep Tank/Sump Immersion Heater with Electrical Enclosure

Electrical Enclosure

- * NEMA 4 housing
- * TEC-4100 PID Temperature Controller
- * Liquid Level Sensor

Immersion Heater

- * 10KW, 480V, 3-Phase Heater
- * Incoloy® 800 Heating Elements
- * 316 SS for all other wetted parts
- * Overall Length: 172 inches

See page 11-82 for additional information.



Panel with Air Conditioner Cooling

This 304 SS, NEMA 4X control panel features a thermostat-controlled, side-mounted air conditioner that maintains safe interior temperatures for the electrical components while operating in high outdoor ambient temperatures.

Turnkey Power Control and Circulation Heating Systems Fuel Circulation Heating System



Control Panel

- * NEMA 4 Control Panel
- * Purge & Pressurization Enclosure Protection System
- * TEC-4100 PID Temperature Controller
- * TEC-410 FM High Limit Control
- * PPR-1800 Videographic Data Logger
- * Safety Contactors for Over-Temperature, Over-Pressure and Low-Flow Conditions
- * Intrinsically Safe Sensor Barriers

Circulation Heater

- * 90KW, 480V, 3-Phase Heater
- * NEMA 4 Terminal Housing
- * Flow Rate: 80 GPM
- * Operating Pressure: 0-150 PSIG
- * Maximum Operating Temperature: 300°F/148°C

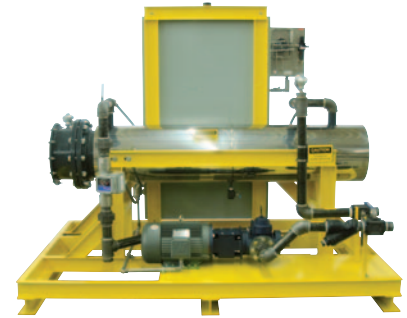

Rear View

- * 10HP TEFC Motor
- * Double Positive Displacement Internal Gear Pump



Fluid Circulation Heating System



Control Panel

- * NEMA 12 enclosure
- * TEC-4100 PID Temperature Controller
- * TEC-410 FM High Limit Control
- * 300A SCR Power Controller
- * Six Heating Circuits
- * Cooling Fan & Filter Kit

Process Heater

- * 200KW, 380V, 3-Phase Heater
- * NEMA 4 Terminal Housing

LDA In-Line Forced Air & Gas Heating — Stainless Steel Inlet Fitting

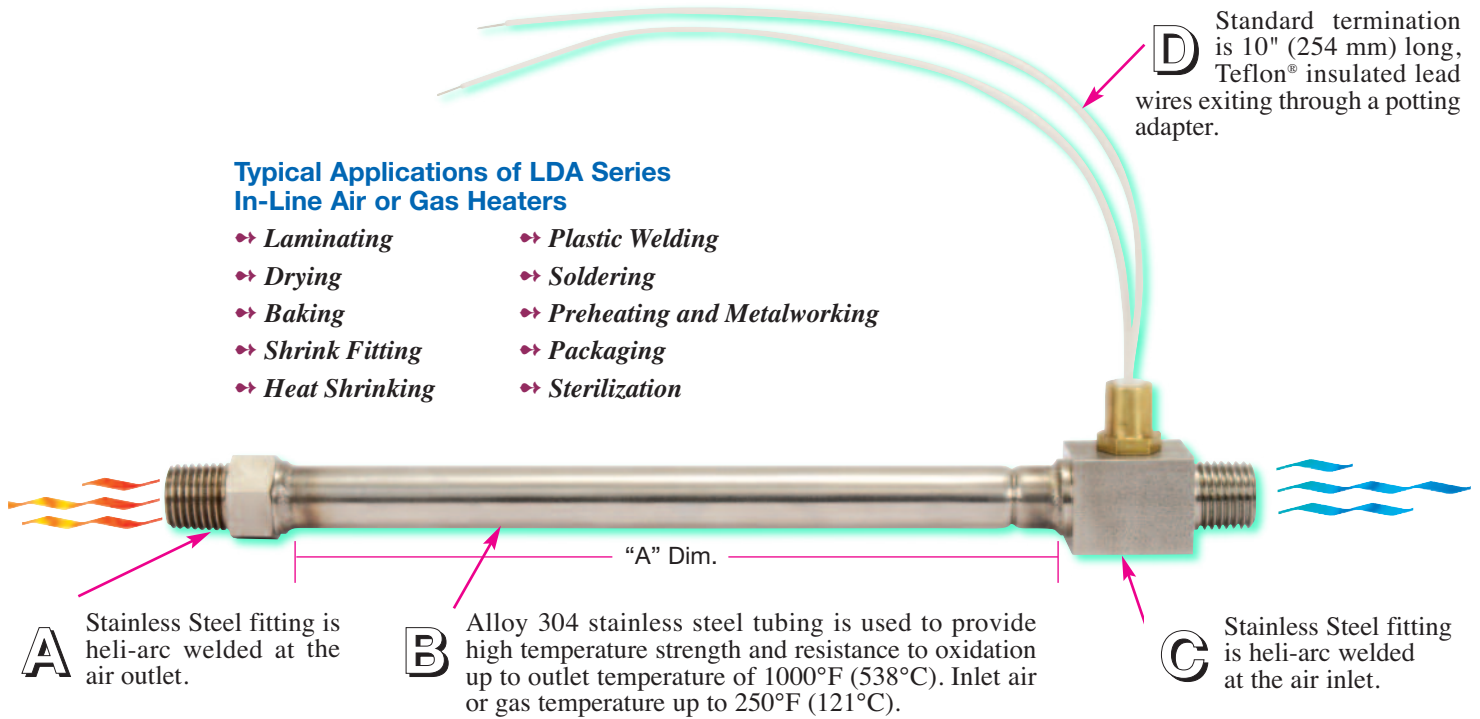

LDA In-Line Air Process Heater Specifications

Heater Diameter (in)	Maximum Amperage	Cross Sectional Flow Area (in ²)	Maximum SCFM (ft ³)	Maximum Wattage/Linear Inch Of Heated Length
3/8	6	.030	8	200
1/2	8	.040	10	250
3/4	15	.120	20	500

Heater Selection

To ensure maximum heater life, heater wattage must be calculated so that it is suitable for the desired air flow. To calculate wattage, determine the air flow and temperature rise required. The following relationship can be used to determine the wattage.

$$\text{Wattage} = \frac{\text{SCFM} \times \text{Temperature rise } (^\circ\text{F})}{3}$$

Table below shows the relationship between standard cubic feet per minute versus maximum watts per linear inch of heated length on different heater diameters.

SCFM	Maximum Watts per Linear Inch of Heated Length		
	3/8" Dia.	1/2" Dia.	3/4" Dia.
2	80	80	120
4	100	100	120
6	150	150	150
8	200	200	200
10	—	250	250
15	—	—	375
20	—	—	500



Air heaters must always have air flowing through them and must operate in a horizontal position to balance the internal resistance coil. Air Heaters can be made in any practical length. These sizes can be adapted with many types of fittings.

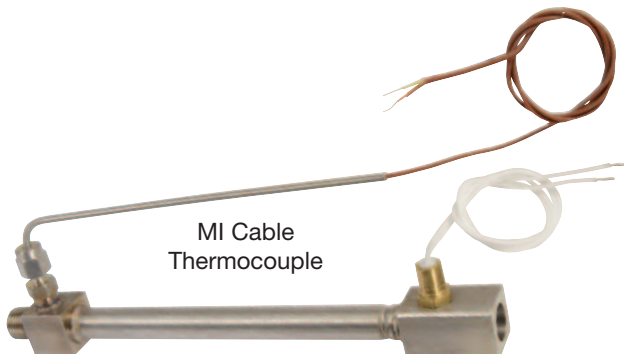

LDA In-Line Forced Air & Gas Heating — Stainless Steel Inlet Fitting

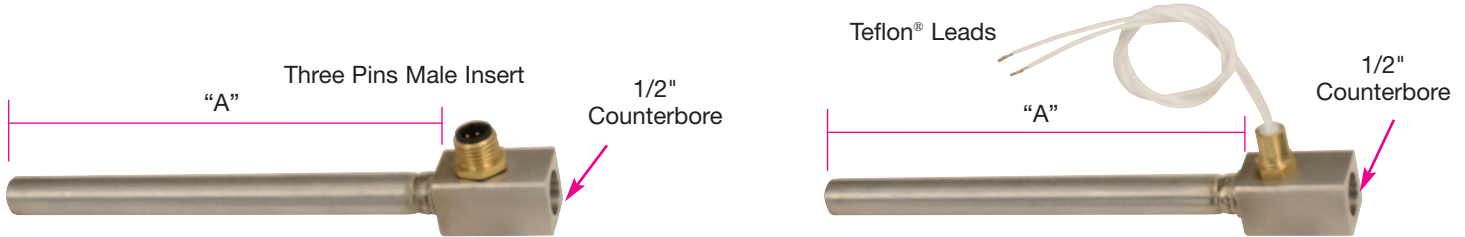

Standard (Non-Stock) In-Line Air Process Heaters

Diameter	"A" in (mm)	Watts	Volts	Connection	Part Number
.500	5½ 139.7	400	120	3 Pins Male Insert	LDA00194
.500	5½ 139.7	400	240	3 Pins Male Insert	LDA00196
.500	5½ 139.7	600	120	3 Pins Male Insert	LDA00197
.500	5½ 139.7	600	240	3 Pins Male Insert	LDA00198
.500	5½ 139.7	400	120	36" Leads	LDA00195
.500	5½ 139.7	400	240	36" Leads	LDA00199
.500	5½ 139.7	600	120	36" Leads	LDA00200
.500	5½ 139.7	600	240	36" Leads	LDA00201

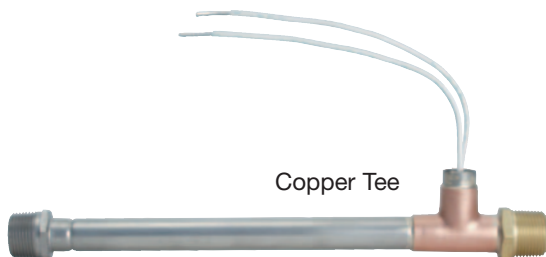
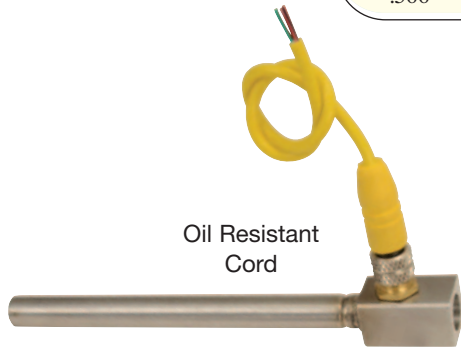

Optional Features

- * Other wattages and voltages
- * Other diameters or lengths
- * 1/8", 1/4", and 3/8" NPT male or female threads are available for the inlet and outlet fittings
- * External MI cable thermocouple
- * Other custom made fittings or flanges
- * S/S cable or braid for lead wire protection
- * SJO cord
- * Explosion proof box

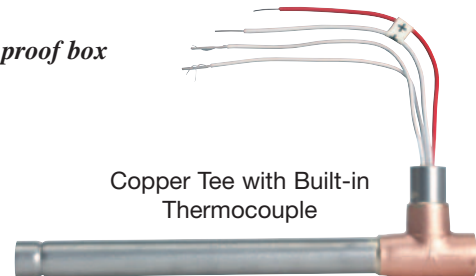

Ordering Information

Catalog Heaters

Order by Part Number for catalog heaters.

Standard lead time is 2-3 weeks.

Custom Engineered/Manufactured Heaters

For sizes and ratings not listed, **TEMPCO** will design and manufacture an LDA In-Line heater to meet your requirements.

Please Specify the following:

- | | |
|---|--|
| <input type="checkbox"/> Diameter | <input type="checkbox"/> Optional Thermocouple |
| <input type="checkbox"/> Inlet-Outlet size and type | <input type="checkbox"/> Pressure |
| <input type="checkbox"/> "A" Dimension | <input type="checkbox"/> Exit Temperature |
| <input type="checkbox"/> Lead Lengths and Type | <input type="checkbox"/> Special Requirements |
| <input type="checkbox"/> Wattage and Voltage | |

⚠ WARNING: Cancer and Reproductive Harm - www.P65Warnings.ca.gov.

HAC In-Line Forced Air Process Heaters

Design Features

- * Two standard sizes:
1/2" diameter × 8" long,
11/16" diameter × 6" long
- * 304 Stainless Steel sheath
- * 120 Volt only
- * Exit air or gas temperature up to 1400°F (760°C)
- * Inlet air or gas temperature up to 250°F (121°C)
- * Ceramic coil support and insulator
- * Three different terminations
- * Customized termination, inlet, outlet, and wattage to customer specification available

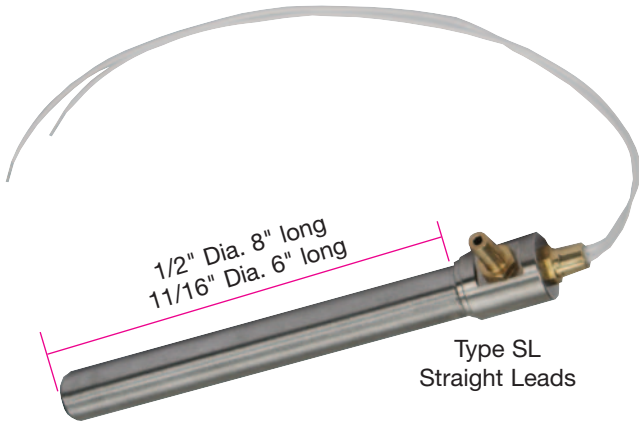

Type SL
Straight Leads

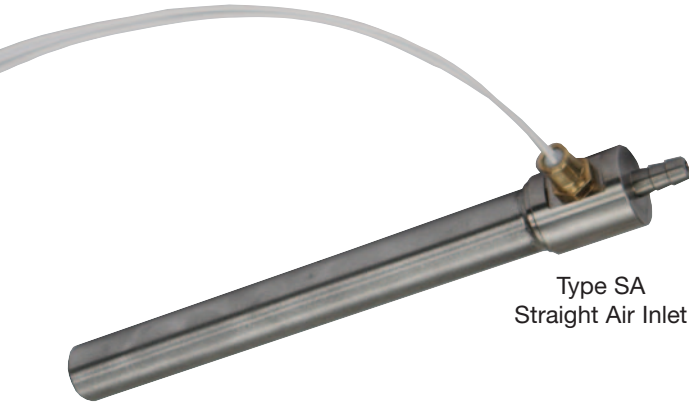

Type SA
Straight Air Inlet



Barbed Fitting
for 1/4" ID Tube

Type NT
90° Air Inlet



Daisy Wound Heating Element

This continuous wound heavy gauge high temperature alloy wire is supported on a custom designed ceramic insulator. This unique coil design rapidly and efficiently removes heat from the resistor wire to achieve higher air/gas temperatures than conventional coil wound designs. The coil assembly is enclosed in a stainless steel housing for safety and durability. Termination can be customized to suit your specific application. Consult Tempco with your requirements.

Standard (Non-Stock) 120V In-Line Air Process Heaters

Heaters have 12" Teflon® leads standard, and the air inlet is a barbed fitting for a 1/4" ID tube.

Termination Type	1/2" Diameter, 120V 8" Heater Length				11/16" Diameter, 120V 6" Heater Length	
	325W	400W	500W	600W	500W	600W
SA	HAC00001	HAC00004	HAC00007	HAC00010	HAC00013	HAC00016
SL	HAC00002	HAC00005	HAC00008	HAC00011	HAC00014	HAC00017
NT	HAC00003	HAC00006	HAC00009	HAC00012	HAC00015	HAC00018



Air heaters must always have air flowing through them and should preferably be operated in a horizontal position. Use clean air.

HAC In-Line Air Process Heaters

Pressure vs. Temperature
(1/2" diameter heaters)

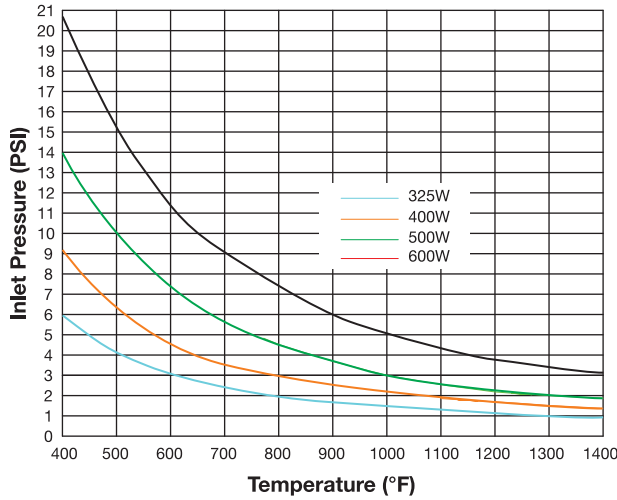

Pressure vs. Temperature
(11/16" diameter heaters)

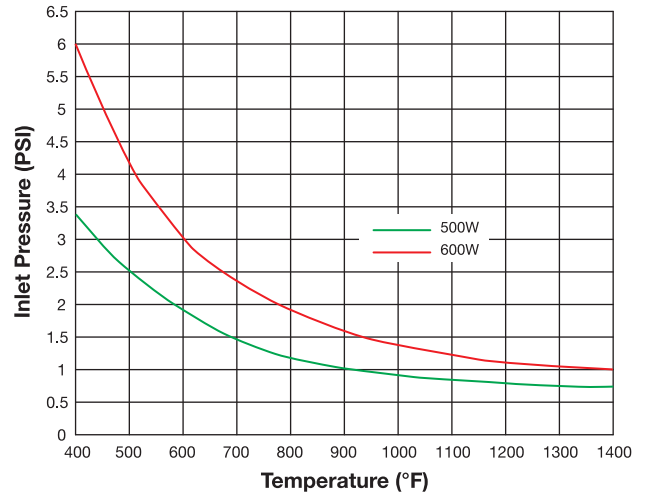

Exit air temperature depends on heater wattage and air flow rate. The above charts show exit air temperature at various inlet air pressures and wattages on 1/2" and 11/16" OD heaters.

Linear Air Pumps for HAC In-Line Air Process Heaters

(Data below is for Pump Part Number PMP-101-101)

Design Features

- * High Efficiency
- * Low Vibration
- * Quiet Operation
- * UL Component Recognition



Temperature vs. Time
(1.1 CFM Pump)

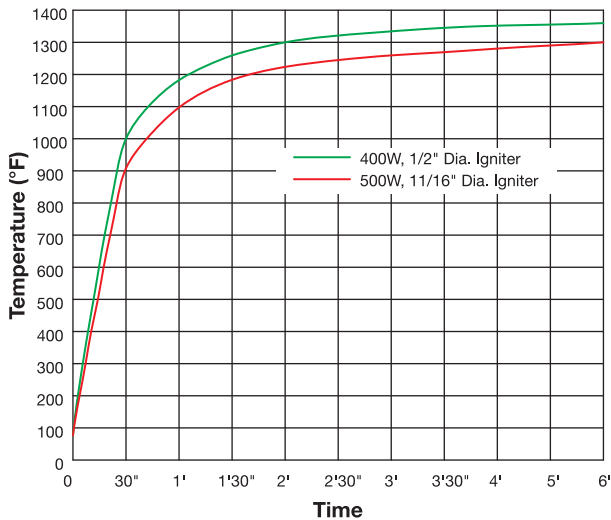

The above chart shows the time for the exit air temperature to reach steady state condition at 1.1 CFM using Tempco's air pump.

Pump Data (Part Number PMP-101-101)

Head Configuration:		Pressure			
Pressure:		Flow @ 115V/60			
CFM@PSI	LPM@BAR	CFM	LPM	Amps	Watts
0	0	1.1	31.1	0.23	15
1	.1	0.62	10.5	0.23	12
2	.2	0.09		0.24	9
Max. Continuous Pressure:		2.0 PSI		0.14 bar	
Max. Intermittent Pressure:		2.32 PSI		0.16 bar	

HAC In-Line heaters can be connected to your air supply lines with an air pressure regulator. For self-contained units, Tempco air pumps can be directly connected to HAC In-Line process heaters. The pump comes with a 12" rubber hose for easy connection to the heater inlet.

Over-the-Side Immersion Heaters

Application

Tempco Over-the-Side Immersion Heaters are specifically designed for heating fluids in tanks. Depending on the tank shape, size, accessibility and working area inside the tank, choose a round or L shaped heater.

Standard sheath materials are Incoloy® 800 and steel with all wetted parts made with compatible alloys.

Construction

Tubular heating elements are welded into a liquid-tight junction box. Power leads for the elements travel up through the riser pipe and are connected to a terminal block in a NEMA 4 Housing. Unless otherwise specified, heaters are wired for three-phase from the factory but can easily be converted to single-phase.

A thermowell for a 3/8" diameter bulb is standard to accommodate an optional thermostat. A thermostat can be field installed to mounting lugs located in the electrical enclosure.

4" (102 mm) sludge legs keep the elements off the bottom of the tank and above any deposits that may accumulate there.

Optional Features

- * 304 or 316 Stainless Steel construction for all wetted parts
- * Passivation of all wetted parts. Electropolished or bright annealed surface treatments for Stainless Steel or Incoloy designs (heating elements only)
- * NEMA 1 or NEMA 4/7 (explosion resistant) terminal housings
- * Flange, fixed or adjustable bracket on riser for mounting
- * Mounting flange for terminal housing
- * External power wiring options include flexible cord/plug, armored cable, wire braided or plain lead wire
- * Double- or Single- pole thermostat (see page 11-6 for available ranges)
- * Process or Hi-limit thermocouple in thermowell in place of the thermostat
- * Hi-limit MI thermocouple on sheath
- * Special riser and/or sludge leg heights
- * Up to 12 elements per heater assembly
- * Right-angle riser design

Design Features

- * Lightweight and Portable
- * Easy Installation and Removal
- * NEMA 4 Electrical Enclosure
- * Single- or Three-Phase Wiring

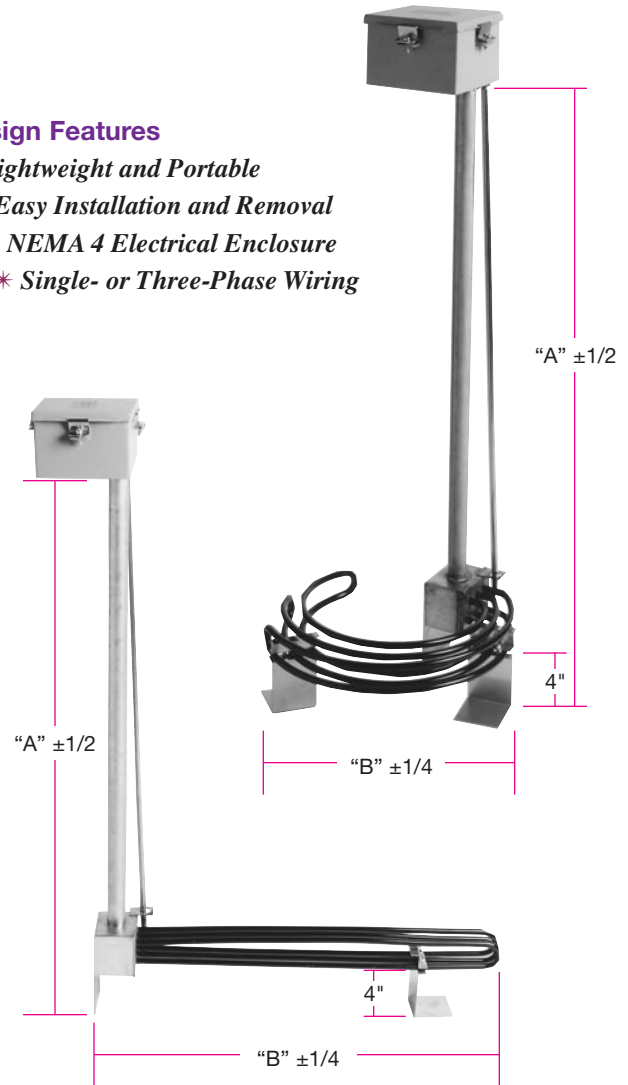

Typical Heating Applications: Lightweight Oils • Degreasing Solutions • Mineral Oil

Design Features

- * Steel Sheath Heating Elements
- * NEMA 4 Terminal Housing
- * Watt Density of 23 watts/in² (3.6 watts/cm²)

Standard (Non-Stock) and Stock Sizes and Electrical Ratings

Stock Items Are Shown In **RED**

Element Shape	"A"		"B"		KW	Part Number		Approximate Net Weight	
	in	mm	in	mm		240V-3Ph	480V-3Ph	lbs	kg
Round	39 ³ / ₁₆	999	13 ¹ / ₂	343	3	TAT20001	TAT20002	17	8
	51 ¹ / ₁₆	1303	18 ¹ / ₂	470	6	TAT20003	TAT20004	20	9
	51 ³ / ₁₆	1303	23 ¹ / ₂	597	9	TAT20005	TAT20006	22	10
Straight	39 ³ / ₁₆	999	22 ³ / ₈	575	3	TAT10001	TAT10002	15	7
	51 ¹ / ₁₆	1303	37 ³ / ₈	956	6	TAT10003	TAT10004	18	8
	51 ³ / ₁₆	1303	52 ³ / ₈	1337	9	TAT10005	TAT10006	20	9



Over-the-Side Immersion Heaters

Typical Heating Applications: Citric and Phosphoric Acid Solutions • Water-Based Chemical Solutions

Design Features

- * Incoloy® Sheath Heating Elements
- * NEMA 4 Terminal Housing
- * Watt Density of 23 watts/in² (3.6 watts/cm²)

Standard (Non-Stock) and Stock Sizes and Electrical Ratings

Stock Items Are Shown In RED

Element Shape	"A"		"B"		KW	Part Number		Approximate Net Weight	
	in	mm	in	mm		240V-3Ph	480V-3Ph	lbs	kg
Round	39 ³ / ₁₆	999	13 ¹ / ₂	343	3	TAT20007	TAT20008	17	8
	51 ³ / ₁₆	1303	18 ¹ / ₂	470	6	TAT20009	TAT20010	20	9
	51 ³ / ₁₆	1303	23 ¹ / ₂	597	9	TAT20011	TAT20012	22	10
Straight	39 ³ / ₁₆	999	22 ³ / ₈	575	3	TAT10007	TAT10008	15	7
	51 ³ / ₁₆	1303	37 ³ / ₈	956	6	TAT10009	TAT10010	18	8
	51 ³ / ₁₆	1303	52 ³ / ₈	1337	9	TAT10011	TAT10012	20	9

Typical Heating Applications: Process Water • Mild Caustic Solutions (2% max.) • Clean Water

Design Features

- * Incoloy® Sheath Heating Elements
- * NEMA 4 Terminal Housing
- * Watt Density of 42 watts/in² (7.4 watts/cm²)

Standard (Non-Stock) and Stock Sizes and Electrical Ratings

Stock Items Are Shown In RED

Element Shape	"A"		"B"		KW	Part Number		Approximate Net Weight	
	in	mm	in	mm		240V-3Ph	480V-3Ph	lbs	kg
Round	39 ³ / ₁₆	999	10 ³ / ₄	273	3	TAT20013	TAT20014	16	7
	39 ³ / ₁₆	999	13 ¹ / ₂	343	6	TAT20015	TAT20016	17	8
	39 ³ / ₁₆	999	16	406	9	TAT20017	TAT20018	18	8
	51 ³ / ₁₆	1303	18 ¹ / ₂	470	12	TAT20019	TAT20020	20	9
	51 ³ / ₁₆	1303	21 ¹ / ₄	540	15	TAT20021	TAT20022	21	10
	51 ³ / ₁₆	1303	23 ¹ / ₂	597	18	TAT20023	TAT20024	22	10
Straight	39 ³ / ₁₆	999	14 ³ / ₈	371	3	TAT10013	TAT10014	14	6
	39 ³ / ₁₆	999	22 ³ / ₈	575	6	TAT10015	TAT10016	15	7
	39 ³ / ₁₆	999	30 ³ / ₈	765	9	TAT10017	TAT10018	16	7
	51 ³ / ₁₆	1303	37 ³ / ₈	956	12	TAT10019	TAT10020	18	8
	51 ³ / ₁₆	1303	45 ³ / ₈	1146	15	TAT10021	TAT10022	19	9
	51 ³ / ₁₆	1303	52 ³ / ₈	1337	18	TAT10023	TAT10024	20	9

Ordering Information

Catalog Heaters

Over-the-Side Immersion Heater Part Numbers in red are in stock for immediate delivery.

Non-Stock Part Numbers are standard designs that are stocked as sub-assemblies for 2-3 week delivery.

Custom Engineered/Manufactured Heaters

An electric heater can be very application specific, for sizes and ratings not listed, **TEMPCO** will design and manufacture an Over-the-Side Immersion Heater to meet your requirements.

Standard lead time is Stock to 3 weeks.

Please Specify the following:

- Application
- Wattage, Voltage and Phase
- Element Sheath Material
- Number of Elements
- Element Watt Density
- "A" and "B" dimensions
- Optional Features
- Quantity

⚠ WARNING: Cancer and Reproductive Harm - www.P65Warnings.ca.gov.

General Purpose Tank or Reservoir Water Immersion Heater

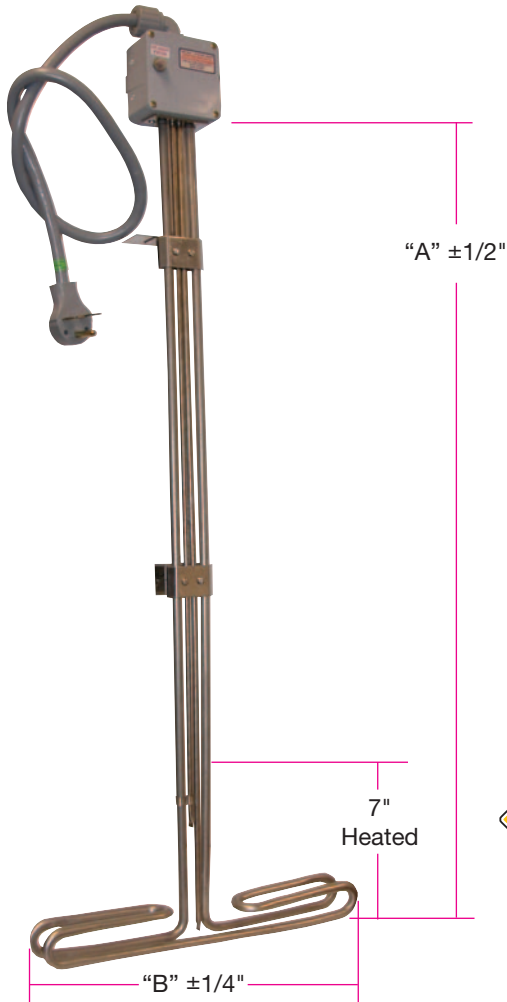

Design Features

- * Immersion section of heater made of 316 Stainless Steel
- * Cold riser extends to the top of container where control housing is located
- * Cord set with 3-wire grounding plug is included for easy installation and wiring.
- * Adjustable vapor-proof thermostat control with temperature range of 55°F to 115°F (±3°)
- * Hi-limit cut switch set to 125°F (±4°)
- * Stainless Steel mounting bracket also supplied for easy mounting
- * Pilot light and on-off switch provided

Hi-Limit:

If the thermostat should fail and its contacts stick in a closed position, the heating element will continue to heat to about 125°F. At this temperature the Hi-Limit will open and turn the heating element off. After repairing or replacing the thermostat the Hi-Limit can be manually reset.



Hazard of electric shock. Installation must be grounded to earth and heater connected to line input through properly sized GFCI circuit breaker.

Disconnect power to heater before servicing. There should be no body contact with the water while the heater is in the water.

Under NO circumstances should this heater be turned on unless the system is full of water.

Standard (Non-Stock) and Stock Sizes and Electrical Ratings

Stock Items Are Shown In RED

Sheath	Watt Density w/in ²	Watts	Volts	"A" Dim. in	"B" Dim. in	Part Number	
						4 ft. cord	6 ft. cord
316 Stainless Steel (Bright Annealed)	51	6000	240	39-3/4	17-1/2	TAT40012	TAT40017
	13	1440	120	39-3/4	17-1/2	TAT40016	TAT40013

Wiring Diagram – Internal Electrical Connections

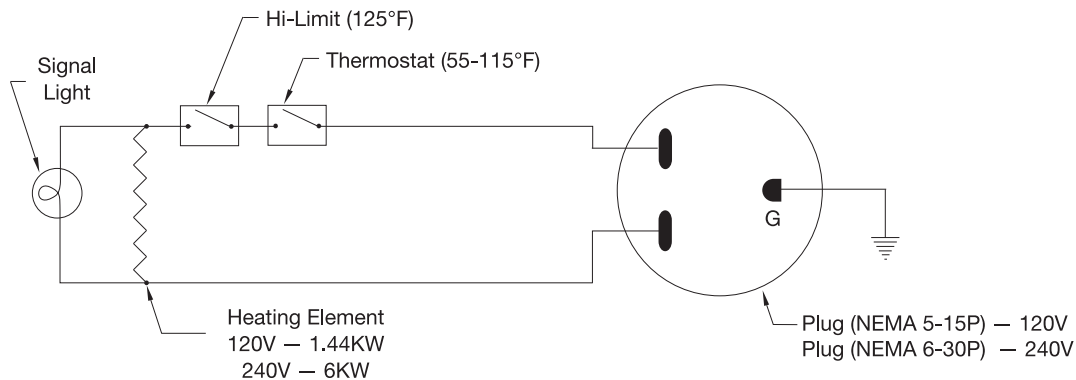

Vertical Loop – Low Profile Immersion Heaters

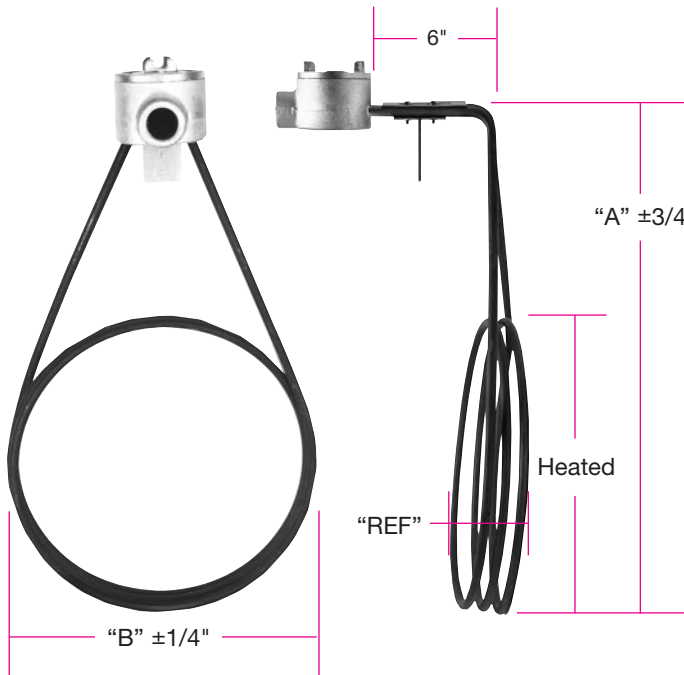

Design Features

- * Used on open-top tanks for heating water, water-based solutions, citrus juices, plating tanks, oil tempering, salt baths and other mild corrosive solutions.
- * NEMA 4 (moisture resistant) housing with integral grounding terminal is standard. Other NEMA ratings available.
- * Low-profile design with adjustable SS mounting bracket.
- * Optional Passivated, Electropolished, or Bright Annealed surface treatments available for Stainless Steel or Incoloy sheath designs.
- * External power wiring options including flexible cord/plug, armor cable, braided or plain lead wire.
- * Optional Hi-limit MI thermocouple on heater sheath.

Standard (Non-Stock) and Stock Sizes

Stock Items Are Shown In **RED**

Sheath	Watt Density		Volts	Dimensions (in)			Part Number
	w/in ²	Watts		"A"	"B"	"REF"	
Copper	25	5000	240	26	15	2	TAT50011
	40	7500	240	26	15	2	TAT50012
Stainless Steel	25	5000	240	26	15	2 3/4	TAT50013
	40	7500	240	26	15	2 3/4	TAT50014
Steel	25	5000	240	26	15	2	TAT50015
	40	7500	240	26	15	2	TAT50016

Standard lead time is Stock to 3 weeks.

Sanitizing Sink Immersion Heaters

Design Features

- * Used for sterilization of water tanks in restaurants, taverns and laboratories
- * Double Pole 60-250°F thermostat with over-temperature cutout. Optional pilot lamp to indicate heater on/off status available.
- * Standard 6 ft. (optional 4 ft.) cord set with grounding plug (NEMA 5-15P for 120V and 6-30P for 240V)
- * Adjustable Stainless Steel mounting bracket
- * Consult Tempco for custom designs

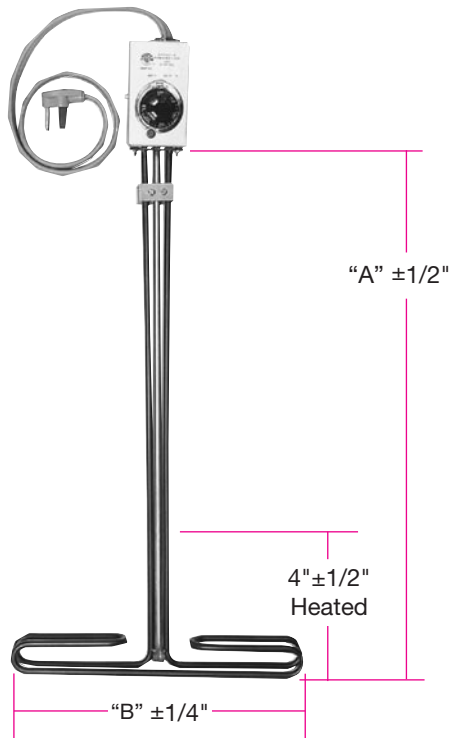

Standard (Non-Stock) and Stock Sizes

Stock Items Are Shown In **RED**

Sheath	Watt Density w/in ²	Watts	Volts	"A" Dim. in	"B" Dim. in	Part Number
316 Stainless Steel (Electropolished)	65	6000	240	26	17	TAT40001
	56	4000	240	26	13	TAT40002
	16	1500	120	26	17	TAT40003
	14	1000	120	26	13	TAT40004
316 Stainless Steel (Bright Annealed)	65	6000	240	26	17	TAT40005
	56	4000	240	26	13	TAT40006
	16	1500	120	26	17	TAT40007
	14	1000	120	26	13	TAT40008

Standard lead time is Stock to 3 weeks.

Ordering Information

Catalog Heaters

Order by Part Number for catalog heaters listed.

Custom Engineered/Manufactured Heaters

Consult Tempco.

⚠ WARNING: Cancer and Reproductive Harm - www.P65Warnings.ca.gov.

Deep Tank/Sump Immersion Heater

Application

These fluid immersion heaters are designed for top mounting in large or deep enclosed tanks having a manhole access or opening suitable to insert & attach the heater. They are usable for either outdoor or indoor applications, within exposed or in-ground tanks and sewerage sumps. They are designed for permanent mounting and can be sealed weather-tight with supplied gaskets and adjustable riser fittings.

NEMA 4 terminal housing is easily removable & resealed to facilitate installation. Units are available with element watt densities from 6 wsi for heavy oils, to 60 wsi for clean water immersion applications. Element bundle diameters ranging from minimum of 10" OD to a maximum of 30" OD are available.

Construction

The tubular elements are welded into a submersible liquid-tight stainless steel junction box. Element power leads are routed up through adjustable riser pipe and connected to a terminal block inside the upper NEMA 4 terminal housing. Unless specified otherwise, heaters are factory wired for three phase and are easily converted to single phase.

All wetted parts are 300 series stainless steel. Standard unit includes 60-250°F double-pole thermostat mounted in upper housing that has a 3/8" dia. bulb & capillary installed in watertight thermowell with adjustable compression fitting.

Design Features

- * .475 diameter Incoloy elements and stainless steel wetted parts standard
- * Designed for permanent installation in outdoor/indoor applications
- * 2 ft to 12 ft vertical riser height (for thermostat designs)
- * Weathertight mounting hardware supplied
- * Riser adjustable to facilitate mounting variations
- * NEMA 4 Electrical Enclosure with 3/4 conduit fitting
- * 1-1/2" Sludge legs
- * Double-pole 60-250°F pilot duty thermostat
- * Watertight thermowell sized for 3/8" max. dia. sensing bulb
- * 120V, 208V, 277V, & 575V versions available (consult Tempco)

Optional Features

- * 316 SS, Steel, or Copper element designs
- * Passivation, electropolished, or bright annealed surface treatments for stainless steel or Incoloy designs (elements only)
- * Custom or ASI pressure rated flange on riser for mounting
- * NEMA 1 or NEMA 4/7 (explosion resistant) terminal housings
- * Alternate single- or double-pole thermostat (see page 11-6 through 11-9 for ranges)
- * Internally mounted definite purpose Magnetic Contactor, single circuit units only (see page 13-96 for volt/amp ratings and coil voltages available)
- * RTD or Process MI thermocouple in thermowell in place of thermostat
- * Hi-limit thermocouple on element sheath
- * Special riser or sludge leg heights
- * Right-angle riser design for offset terminal housing
- * Up to 24 elements per heater assembly
- * 1/32 DIN temperature controller, internal or panel mounted on terminal housing and used with T/C or RTD probe & contactor for heater control
- * Integrated float switch for liquid level control



Deep Tank/Sump Immersion Heaters

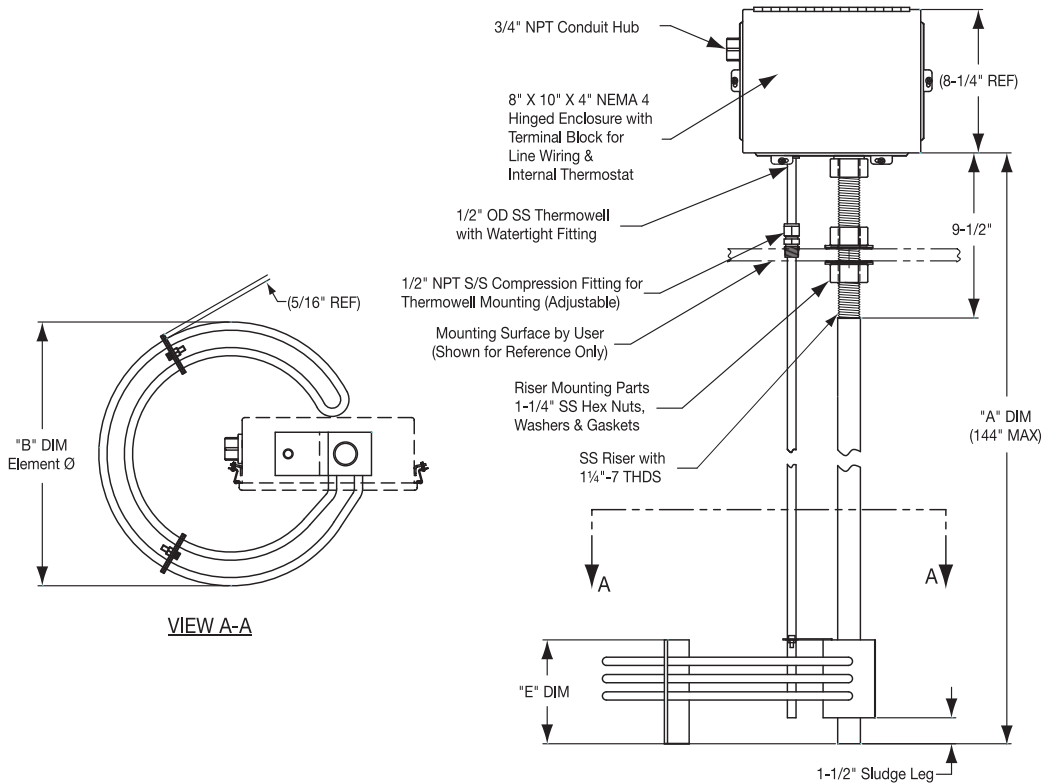

Standard (Non-Stock) Deep Tank & Sump Immersion Heaters – 12 watts/sq. in.

KW	Number of Elements	"A" Dim. in	"B" Dim. in	"E" Dim. in	Part Number			
					240V-1Ph	240V-3Ph	480V-1Ph	480V-3Ph
4	3	72	15-1/4	7-1/2	TAT60001	TAT60002	TAT60003	TAT60004
8	6	72	15-1/4	10-1/2	TAT60005	TAT60006	TAT60007	TAT60008
12	9	72	15-1/4	13-1/2	TAT60009	TAT60010	TAT60011	TAT60012
15	12	72	15-1/4	16-1/2	—	TAT60013	TAT60014	TAT60015
20	15	72	15-1/4	19-1/2	—	TAT60016	TAT60017	TAT60018
30	24	72	15-1/4	28-1/2	—	—	TAT60019	TAT60020

Ordering Information

Custom Engineered/Manufactured Heaters

An electric heater can be very application specific; for sizes and ratings not listed, **TEMPCO** will design and manufacture an Over-the-Side Immersion Heater to meet your requirements.

Standard lead time is 4 weeks.

Please Specify the following:

- Application
- Wattage, Voltage and Phase
- Element Sheath Material
- Number of Elements
- Element Watt Density
- "A" and "B" dimensions
- Optional Features
- Quantity

Catalog Heaters
Order-by Part Numbers.

⚠ WARNING: Cancer and Reproductive Harm - www.P65Warnings.ca.gov.

Tank Immersion Heaters

Over-the-Side Chemical Bath Immersion Heaters

Tempco Over-the-Side Chemical Bath Immersion Heaters offer a wide variety of sheath materials and heater configurations to cover the widest possible spectrum of chemical heating applications. From plain steel to PTFE covered, Tempco is sure to have the correct heater for even the most difficult solution.

Built-in thermal overload protection prevents premature heater burnout in low liquid level conditions. This thermal protection also guards against a potentially hazardous situation should the heater be in close proximity to combustibles, such as a plastic tank or the medium being heated.

3 Construction Styles to select from...



Teflon®

- Low watt density for long service life
- Non-contaminating .030 PTFE covered stainless steel element
- Lightweight, non-floating construction
- Polypropylene guards (optional PTFE guards for chromic acids or solutions exceeding 180°F)



Quartz

- Replaceable element and quartz tube
- Standard heater with polypropylene guard (optional PTFE guards for chromic acids or solutions exceeding 180°F)



Metal Tube

- Variety of materials including steel, SS 304, SS 316, and titanium for chemical compatibility
- Rugged, long-lasting construction

Design Features

- * Heavy duty, long-lasting construction
- * Standard thermal protection
T1 replaceable, standard
T2 resettable, optional
- * Fully grounded for safety
- * Vapor-tight polypropylene terminal enclosure
- * Standard 3 ft. flexible PVC liquid-tight conduits and leads



Agency
Approval

Tempco TMT, TMM (except plain steel) and KMH (up to 4KW/assembly) are UL listed in the US and for Canada under UL File Number E176527.

Application Guide for Thermal Over-Temperature Devices

T1 Thermal Fuse Devices

The T1 Over-Temperature Device is a eutectic switch with a pre-specified melt temperature. The “one shot” characteristic is useful in alerting operators to identify and remedy the cause of the over-temperature condition in the course of T1 fuse replacement.

UL listed rating of 15 Amps up to 277 Vac

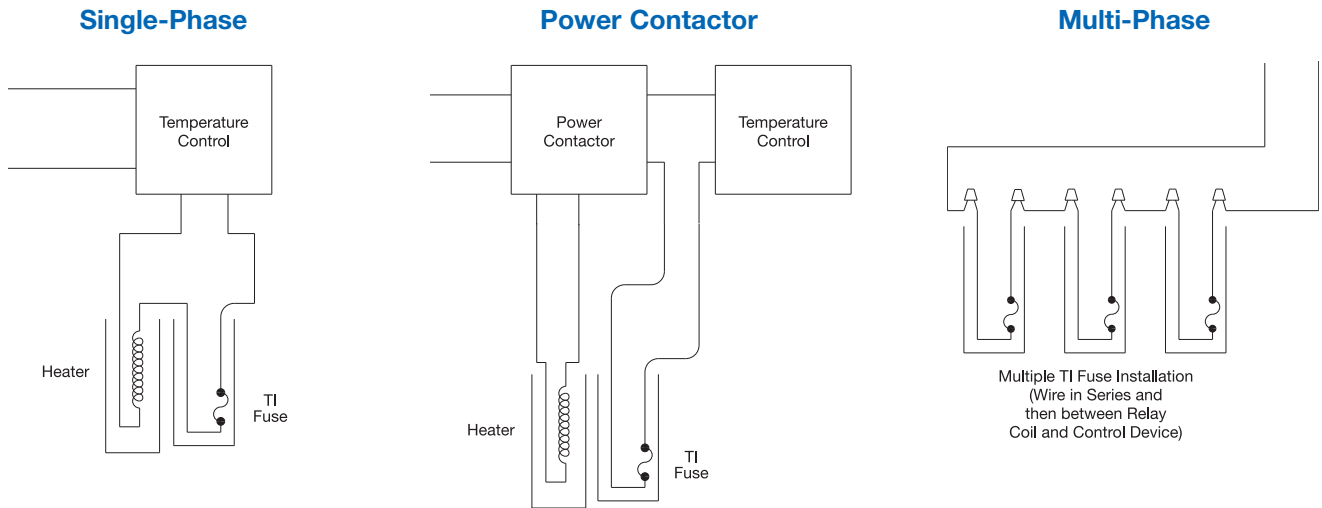

T2 Bi-Metal Switch

The T2 Over-Temperature Device is a slow make/slow break bimetallic thermostat with a pre-specified calibration temperature. The slow break characteristic coupled with the pushbutton reset feature is extremely useful when a low liquid level occurs.

The T2 Over-Temperature Device is electrically installed with a holding circuit in conjunction with a power contactor to energize the heater. **The T2 device must never be used to directly control heater power.**

UL listed rating of 6 Amps @ 120 Vac or 4 Amps @ 240 Vac

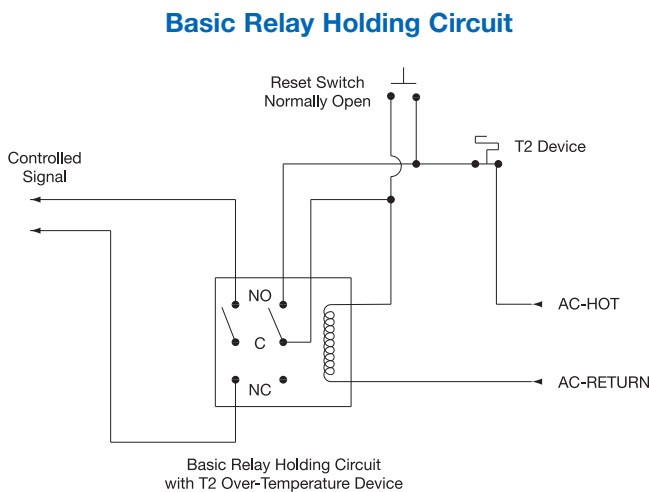

Typical Installation

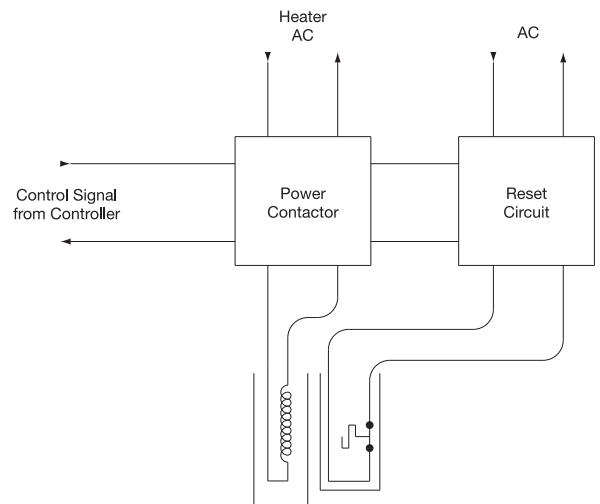

- NOTE:**
- Multiple heaters are hooked up according to standard electrical practices.
 - Multiple T2 devices are hooked up in series on one reset circuit.

Replacement Thermal Protection Accessories

Various construction methods are used in the manufacture of PTFE, Quartz and Metal Tube Over-the-Side Immersion Heaters.

The T1 or T2 Thermal Protection Devices are matched to the item they protect for lead length and mounting style.

T1 Thermal Fuse Devices

Description	Catalog Number
T1 Thermal Fuse for PTFE Over-the-Side Heaters (to 190°F)	TMC90001
T1 Thermal Fuse for PTFE L-Shaped Over-the-Side Heaters (to 190°F)	TMC90004
T1 Thermal Fuse for Quartz Over-the-Side Heaters (w/SS Braid Sleeving)	
• Low Temperature Range (to 180°F)	TMC90002
• Medium Temperature Range (to 220°F)	TMC90003
T1 Thermal Fuse for Straight Metal Over-the-Side Heaters	
• Low Temperature Range (to 180°F)	TMC90005
• Medium Temperature Range (to 220°F)	TMC90006
• High Temperature Range (to 300°F)	TMC90007
T1 Thermal Fuse for L-Shaped Metal Over-the-Side Heaters	
• Low Temperature Range (to 180°F)	TMC90008
• Medium Temperature Range (to 220°F)	TMC90009
• High Temperature Range (to 300°F)	TMC90010

T2 Bi-Metal Switch

Description	Catalog Number
T2 Bi-Metal Switch for PTFE Over-the-Side Heaters (rated to 190°F)	TMC90101
T2 Bi-Metal Switch for PTFE L-Shaped Over-the-Side Heaters (to 190°F)	TMC90111
T2 Bi-Metal Switch for Quartz Over-the-Side Heaters (w/SS Braid Sleeving)	
• Low Temperature Range (to 180°F)	TMC90102
• Medium Temperature Range (to 220°F)	TMC90103
T2 Bi-Metal Switch for Straight Metal Over-the-Side Heaters	
• Low Temperature Range (to 180°F)	TMC90105
• Medium Temperature Range (to 220°F)	TMC90106
• High Temperature Range (to 300°F)	TMC90107
T2 Bi-Metal Switch for L-Shaped Metal Over-the-Side Heaters	
• Low Temperature Range (to 180°F)	TMC90108
• Medium Temperature Range (to 220°F)	TMC90109
• High Temperature Range (to 300°F)	TMC90110

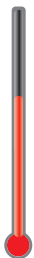

- High Temperature Range**— Solutions from 220°F to 300°F (104.4°C to 149.0°C)
- Medium Temperature Range**— Solutions from 180°F to 220°F (82.2°C to 104.4°C)
- Low Temperature Range**— Solutions up to 180°F (82.2°C)

Thermal Over-Temperature Protection



The realities of any plating, cleaning, anodizing, etching or pickling operation are that something could go wrong such as:

- ◆ An undetected tank leak
- ◆ Undetected evaporation losses
- ◆ Failure to refill the system

Any of these conditions creates a situation where the potential for fire or other hazard is increased.

Standard Setup — All Tempco Over-the-Side Teflon®, quartz and metal tube heaters come equipped with a replaceable thermal fuse placed in a thermowell and positioned at the top of the heater's hot zone. When wired into the heater circuit, it will instantly cut power to the heater when the preset temperature is reached. If the heater is over 15 amp, the thermal fuse would be wired into the control relay circuit. Also available is the T2 bi-metal switch which would be wired into the control relay circuit and used with additional components to form a resettable system.

We highly recommend the use of liquid level switches tied into control circuitry to provide a failsafe backup to the thermal fuse.

Chemical Bath Temperature Control Systems

Single-Phase Non-Indicating Thermostat 12/25 Amp Output



Design Features

- * FEP sleeved bulb and capillary for chemical resistance; 5 or 12 ft. available
- * Double pole, 120 or 240 Volt operation
- * Enclosure: 3.75" x 5.87" x 3.375" deep
Mounting centers: 2.62" x 6.25"

Standard (Non-Stock) Sizes and Ratings

Part Number	Volts	Amps	Temperature Range	Capillary Length ft (mm)	Shipping Weight Lbs (kg)
TMC11001	120/240	12/25	30° to 220°F	5 (1525)	3 (1.5)
TMC11002	120/240	12/25	200 to 550°F	12 (3660)	3 (1.5)
TMC11003	120/240	12/25	200 to 550°F	5 (1525)	3 (1.5)

Standard lead is 2 to 3 weeks.



Note: Amperage is limited to 12A, if operating a heater in series with a Thermal Fuse Protector.

1- or 3-Phase Non-Indicating Thermostat Control Systems: 20 - 125 Amps



Design Features

- * FEP sleeved bulb and capillary for chemical resistance; 5 ft. standard or 12 ft. available
- * Gasketed plastic enclosure for corrosion resistance
- * 240 or 480 Volt operation
- * 3-pole contactor for single- or three-phase operation
- * 20 - 125 Amp capability

Standard (Non-Stock) Sizes and Ratings

Part Number		Volts	Amps	Shipping Weight Lbs (kg)
Temperature Range 30 to 220°F	Temperature Range 200 to 550°F			
TMC11040	TMC11048	240	20	15 (7)
TMC11041	TMC11049	480	20	15 (7)
TMC11042	TMC11050	240	40	16 (7.5)
TMC11043	TMC11051	480	40	16 (7.5)
TMC11044	TMC11052	240	80	24 (11)
TMC11045	TMC11053	480	80	24 (11)
TMC11046	TMC11054	240	125	32 (14.5)
TMC11047	TMC11055	480	125	32 (14.5)

Standard lead is 2 to 3 weeks.

NOTE: The control systems listed above have a 5 ft. bulb and capillary, 3-pole mechanical relay, step-down control transformer.

Enclosure Dimensions (in.)

	Length	Width	Depth	C-C Length	C-C Width
	A	B	C	D	E
20 to 40 Amps	14.375	9.63	6.25	13.625	6.0
80 Amps	18.0	13.75	7.625	17.0	10.0
125 Amps	20.25	15.75	8.375	19.25	12.0



Note: User is responsible for fuses or circuit breaker for main power.



Chemical Compatibility Guide

SOLUTION	TYPE OF HEATER	SOLUTION	TYPE OF HEATER
Acetic	PTFE or Quartz	Chromium (No Fluorides)	PTFE, Quartz or Titanium
Acid Sulfate	PTFE or Quartz	Citric Acid	Titanium
Actane 70, 80	PTFE	Clear Chromate	PTFE or Quartz
Actane Salt	PTFE	Cobalt Nickel	PTFE, Quartz or Titanium
Alcorite	PTFE or Quartz	Cobalt Plating	304 Stainless Steel
Alkaline Cleaners (Electrified)	304 Stainless Steel	Cobra Etch	PTFE
Alkaline Soaking Cleaners	304 Stainless Steel	Copper Acid	PTFE or Quartz
Alodine (most formulas)	316 Stainless Steel	Copper Bright Acid	PTFE or Quartz
Alstan	304 Stainless Steel	Copper Cyanide	304 Stainless Steel
Aluminum Anodizing	PTFE or Quartz	Copper Fluoborate	PTFE
Aluminum Bright Dip	PTFE or Quartz	Copper Pyrophosphate	304 Stainless Steel
Aluminum Chloride	PTFE or Quartz	Copper Strike	304 Stainless Steel
Aluminum Cleaners	304 Stainless Steel	Copper Sulfate	PTFE or Quartz
Aluminum Sulfate	304 Stainless Steel	Cyanide	304 Stainless Steel
Ammonia	304 Stainless Steel	Deionized Water	316 Stainless Steel
Ammonia Persulfate	PTFE or Quartz	Deoxidizer (Etching)	PTFE or Quartz
Ammonium Bi Fluoride	PTFE	Deoxidizer Non-Chromated	316 Stainless Steel
Ammonium Chloride	Titanium	Dichromic Seal	Steel
Ammonium Nitrate	316 Stainless Steel	Diethylene Glycol	304 Stainless Steel
Anodizing	PTFE or Quartz	Diversey, 511, 514	PTFE
ARP 28, 80 Blackening Salts	PTFE or Quartz	Dow Therm	316 Stainless Steel
Arsenic	304 Stainless Steel	Dye Solutions	304 Stainless Steel
Barium Chloride	Titanium	Ebonal C	Titanium
Benzoic Acid	Titanium	Electro Cleaner	304 Stainless Steel
Black Nickel	PTFE or Quartz	Electro Polishing	PTFE or Quartz
Black Oxide (High-Temp)	304 Stainless Steel	Electroless Copper	PTFE
Black Oxide (Low-Temp)	Titanium	Electroless Nickel	PTFE or Titanium
Bonderizing	316 Stainless Steel	Electroless Tin (Acid)	PTFE or Quartz
Boric Acid	Titanium	Electroless Tin (Alkaline)	316 Stainless Steel
Brass Cyanide	304 Stainless Steel	Enthone 80 Acid	PTFE
Bright Copper-Cyanide	304 Stainless Steel	Ethylene Glycol	Steel
Bright Nickel	PTFE, Quartz or Titanium	Ferric Ammonium Oxide	316 Stainless Steel
Bronze	304 Stainless Steel	Ferric Chloride	PTFE, Quartz or Titanium
Brown Oxide	Titanium	Ferric Nitrate	304 Stainless Steel
Burnite	PTFE or Quartz	Ferric Sulfate	304 Stainless Steel
Butyric Acid	Titanium	Fluoborate	PTFE
Cadmium (Alkaline)	304 Stainless Steel	Formic Acid	316 Stainless Steel
Cadmium Black	PTFE or Quartz	Glycerol	304 Stainless Steel
Cadmium Fluoborate	PTFE	Gold-Acid	PTFE, Quartz or Titanium
Calcium Chloride	Titanium	Gold Cyanide	304 Stainless Steel
Calcium Hypochlorite	Titanium	Gold-Immersion	304 Stainless Steel
Carbonic Acid	Titanium	Grey Nickel	PTFE, Quartz or Titanium
Caustic Etch	Steel	Hot Seal Dichromate	316 Stainless Steel
Caustics	Steel	Hydrochloric Acid	PTFE or Quartz
Caustics (highly concentrated 20% & over)	Steel	Hydrofluoric Acid	PTFE
Chloride	PTFE, Quartz or Titanium	Hydrogen Peroxide	PTFE or Quartz
Chlorine/Wet	PTFE or Quartz	Indium	PTFE or Quartz
Chlorosulfuric Acid	Titanium	Iridite (1, 2, 3, 4-C, 7, 8, 15)	PTFE or Quartz
Chromic Acetate	PTFE or Quartz	Iridite (4-75, 4-73, 14, 14-2, 14-9)	316 Stainless Steel
Chromic Anodizing	PTFE or Quartz	Iron Fluoborate	PTFE
Chromic Nickel	PTFE or Quartz	Iron Phosphate	316 Stainless Steel
Chromium (Fluoride)	PTFE	Isoprep (186, 187, 188)	316 Stainless Steel

Chemical Compatibility Guide

SOLUTION	TYPE OF HEATER	SOLUTION	TYPE OF HEATER
Isoprep Acid Salts	PTFE	Silver Lume	304 Stainless Steel
Jetal	304 Stainless Steel	Silver Nitrate	316 Stainless Steel
Lead Acetate	304 Stainless Steel	Sodium Bisulfate	PTFE or Quartz
Lime Saturated Water (Alkaline)	316 Stainless Steel	Sodium Carbonate	Titanium
Linseed Oil	304 Stainless Steel	Sodium Chlorate	Titanium
Magnesium Hydroxide	304 Stainless Steel	Sodium Chloride	Titanium
Magnesium Nitrate	PTFE or Quartz	Sodium Cyanide	304 Stainless Steel
Manganese Phosphate	316 Stainless Steel	Sodium Dichromate (Hot Seal)	316 Stainless Steel
McDermid 629	PTFE	Sodium Hydroxide	Steel
Mercuric Chloride	Titanium	Sodium Hypochlorite	PTFE
Muriatic Acid	PTFE or Quartz	Sodium Persulfate	PTFE or Quartz
Nickel (Plating Solution) (Watts)	PTFE, Quartz or Titanium	Stannate	Steel
Nickel Acetate Seal	316 Stainless Steel	Stanostar	PTFE or Quartz
Nickel Chloride	Titanium	Stearic Acid	Quartz
Nitric Acid	PTFE or Quartz	Sulfamate Nickel	PTFE, Quartz or Titanium
Nitric Hydrochloric Acids	PTFE or Quartz	Sulfur	PTFE or Quartz
Nitric Phosphoric	Quartz	Sulfur Peroxide	PTFE or Quartz
Oil	Steel	Sulfuric Acid	PTFE or Quartz
Oleic Acid	PTFE or Quartz	Sulphamic Acid	PTFE or Quartz
Oxalic Acid	PTFE or Quartz	Tannic Acid	Titanium
Paint Stripper (Alkaline)	304 Stainless Steel	Tin Nickel	PTFE
Perchlorethylene	316 Stainless Steel	Tin Plating (Acid) (Fluoborate)	PTFE
Phosphate	316 Stainless Steel	Tin Plating (Acid) (Stanus/Sulphate)	PTFE or Quartz
Phosphate Cleaner	304 Stainless Steel	Tin Plating (Alkaline)	304 Stainless Steel
Phosphoric Acid (No Fluoride)	PTFE or Quartz	Trichlorethylene	316 Stainless Steel
Potassium Acid Sulfate	PTFE or Quartz	Trioxide (Pickle)	PTFE or Quartz
Potassium Cyanide	304 Stainless Steel	Turco (4181, 4338)	316 Stainless Steel
Potassium Hydrochloric	PTFE or Quartz	Unichrome	PTFE or Quartz
Potassium Hydroxide	304 Stainless Steel	Water	316 Stainless Steel or Quartz
Potassium Permanganate	PTFE or Titanium	Wood's Nickel Strike	PTFE, Quartz or Titanium
Rhodium	PTFE or Quartz	Yellow Dichromate	PTFE or Quartz
Rochelle Salt Cyanide	304 Stainless Steel	Zinc Acid	PTFE or Titanium
Ruthenium	PTFE or Quartz	Zinc Ammonium Chloride	Quartz or Titanium
Salt (Actine)	PTFE	Zinc Cyanide	304 Stainless Steel
Sea Water	Titanium	Zinc Phosphate	316 Stainless Steel
Silver Bromide	316 Stainless Steel	Zinc Phosphate (Fluoride)	PTFE
Silver Cyanide	304 Stainless Steel	Zincate	304 Stainless Steel

Solutions requiring derated heaters are indicated in red type.

PTFE is the abbreviation for PolyTetraFluoroEthylene.



Note: The data listed is provided as a reference and is offered as a guide only. It is not intended to be used as the sole basis of design or to establish specification limits. **Tempco Electric Heater Corporation** assumes no obligation or liability for any advice furnished by it or for results obtained from its use. Due to the complexities of solutions and applications, it is the customer's responsibility to contact their chemical supplier for heater material compatibility and recommendations. Ultimate responsibility lies with the user.

Do not use electric immersion heaters to heat flammable solutions!



Please insure applicability of heater before installation since we cannot guarantee heaters against premature failure due to corrosion or chemical destruction caused by unusual conditions over which we have no control such as:

- Excessively high solution temperatures
- The concentration of the solution
- The presence of inhibitors
- The presence of other acids causing a secondary reaction
- Stray electrical currents
- Flux floating on the surface
- The presence of dissolved gases
- Excessive sludge buildup
- Aeration
- Stagnant or turbulent flow of the solution
- Presence of oxygen or an oxidizing agent in the solution
- Erosion
- High Pressures or Vacuum Conditions

Tank Immersion Heaters

Fluoropolymer (PTFE) Single-Element Coil Heater

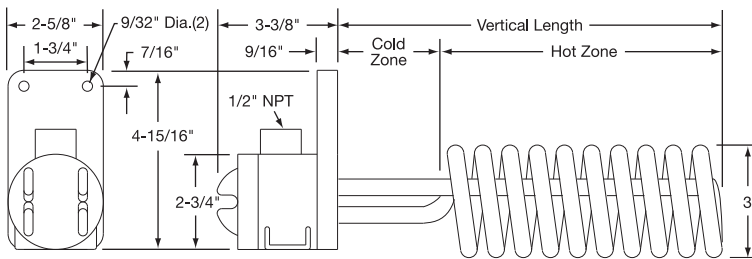
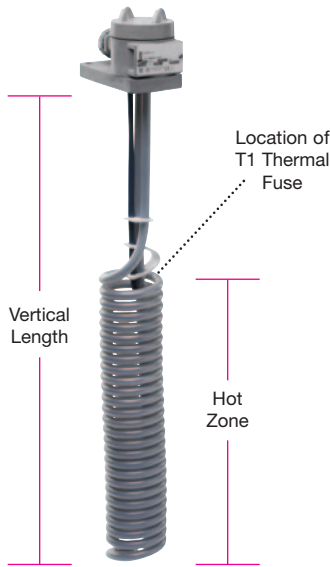

Typical Applications

Compatible with most plating tank solutions; inert to acids, anodizing and pickling solutions up to 190°F (88°C). Check compatibility guide on pages 11-88 and 11-89 and with chemical supplier for proper sheath material selection.

Replaces more expensive alumina or graphite heaters.

Design Features

- * 10 watts/in² (1.6 watts/cm²) for long service life
- * Non-contaminating Fluoropolymer (PTFE) covered stainless steel elements
- * T1 thermal fuse protection standard; T2 bi-metal switch optional
- * Grounded internal metal element for safety
- * UL listed for US and Canada
- * Lightweight, non-floating construction
- * Vapor-tight polypropylene terminal enclosure with universal mounting flange
- * Standard 3-ft. flexible PVC liquid-tight conduit
- * Single-Phase only
- * 120, 240, 480 volts standard as listed — other voltages available
- * Longer and shorter vertical lengths available; consult Tempco

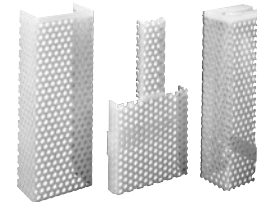

Note: Guards are recommended for all fluoropolymer heaters. Standard guards are made of polypropylene. Fluoropolymer (PTFE) guards are available for chromic acid and temperatures above 180°F (82°C).

Standard (Non-Stock) Sizes and Ratings with Polypropylene Guard

Watts	Part Number			Hot Zone		Vertical Length	
	120V	240V	480V	in	mm	in	mm
500	TMT01001	TMT01002	—	5	127	11	279
1000	TMT01003	TMT01004	—	7	178	11	279
2000	TMT01005	TMT01006	TMT01007	12	305	17	432
3000	—	TMT01008	TMT01009	16	406	23	584
4000	—	TMT01010	TMT01011	20	508	29	737
5000	—	TMT01012	TMT01013	25	635	35	889
6000	—	TMT01014	TMT01015	29	737	40	1016

Ordering Information

Catalog Heaters

The part numbers given are for the complete assembly including the heater, poly guard, and T1 thermal protector.

Other optional assemblies may be ordered; consult Tempco for the catalog number.

Custom Engineered/Manufactured Heaters

For sizes and ratings not listed, **TEMPCO** will design and manufacture a heater to meet your requirements. **Standard lead time is 2 to 3 weeks.**

Please Specify the following:

- Hot Zone and Vertical Length per model
- Voltage and Wattage
- PVC liquid-tight conduit length (3 ft. standard)

WARNING: Cancer and Reproductive Harm - www.P65Warnings.ca.gov.

Fluoropolymer (PTFE) Single-Element L-Shaped Coil Heater

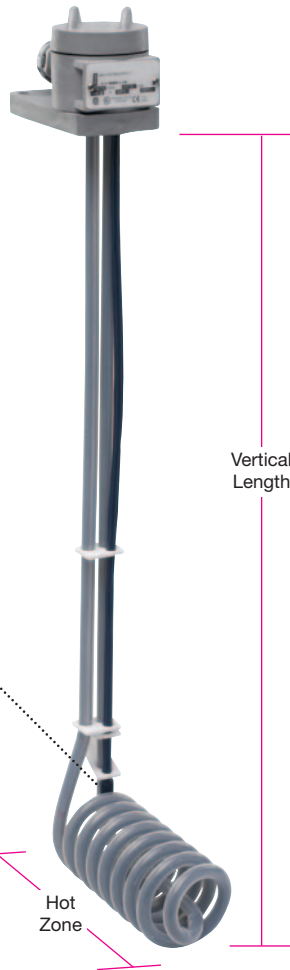

Typical Applications

Compatible with most plating tank solutions; inert to acids, anodizing and pickling solutions up to 190°F (88°C). Check compatibility guide on pages 11-88 and 11-89 and with chemical supplier for proper sheath material selection.

Replaces more expensive alumina or graphite heaters.

Design Features

- * Bottom design for even heating and varying liquid levels
- * 10 watts/in² (1.6 watts/cm²) for long service life
- * Non-contaminating Fluoropolymer (PTFE) covered stainless steel elements
- * T1 thermal fuse protection standard; T2 bi-metal switch optional
- * Grounded internal metal element for safety
- * UL listed for US and Canada
- * Lightweight, non-floating construction
- * Vapor-tight polypropylene terminal enclosure with universal mounting flange
- * Standard 3-ft. flexible PVC liquid-tight conduit
- * Single-Phase only
- * 120, 240, 480 volts standard as listed — other voltages available
- * Longer and shorter vertical lengths available; consult Tempco.

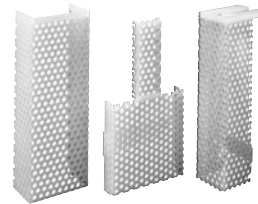
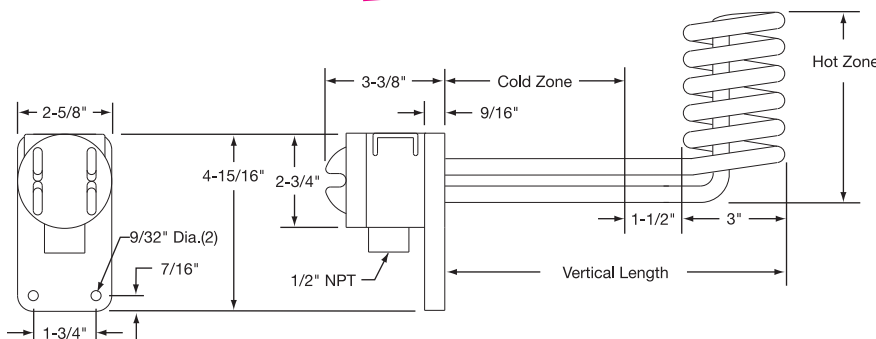

Note: Guards are recommended for all fluoropolymer heaters. Standard guards are made of polypropylene. Fluoropolymer (PTFE) guards are available for chromic acid and temperatures above 180°F (82°C).

Ordering Information

See page 11-90

Standard (Non-Stock) Sizes and Ratings with Polypropylene Guard

Watts	Part Number			Hot Zone		Vertical Length	
	120V	240V	480V	in	mm	in	mm
500	TMT02001	TMT02002	—	6	152	12	305
1000	TMT02003	TMT02004	—	8	203	12	305
2000	TMT02005	TMT02006	TMT02007	12	305	18	457
3000	—	TMT02008	TMT02009	17	432	18	457
4000	—	TMT02010	TMT02011	20	508	18	457
5000	—	TMT02012	TMT02013	24	610	18	457
6000	—	TMT02014	TMT02015	29	737	18	457

Standard lead time is 2 to 3 weeks.

Fluoropolymer (PTFE) Single-Element Round Heater

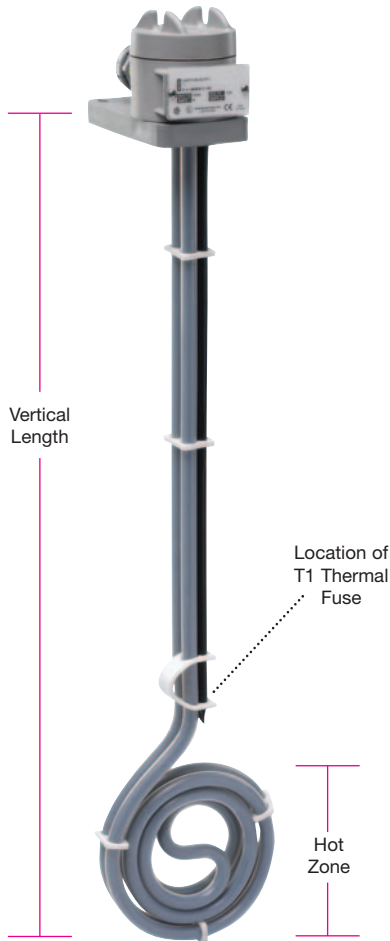

Typical Applications

Compatible with most plating tank solutions; inert to acids, anodizing and pickling solutions up to 190°F (88°C). Check compatibility guide on pages 11-88 and 11-89 and with chemical supplier for proper sheath material selection.

Replaces more expensive alumina or graphite heaters.

Design Features

- * Flat, low profile design
- * 10 watts/in² (1.6 watts/cm²) for long service life
- * Non-contaminating Fluoropolymer (PTFE) covered stainless steel elements
- * T1 thermal fuse protection standard; T2 bi-metal switch optional
- * Grounded internal metal element for safety.
- * UL listed for US and Canada
- * Lightweight, non-floating construction
- * Vapor-tight polypropylene terminal enclosure with universal mounting flange
- * Standard 3-ft. flexible PVC liquid-tight conduit.
- * Single-Phase only
- * 120, 240, 480 volts standard as listed — other voltages available
- * Longer and shorter vertical lengths available; consult Tempco

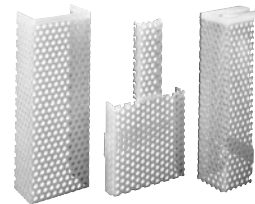
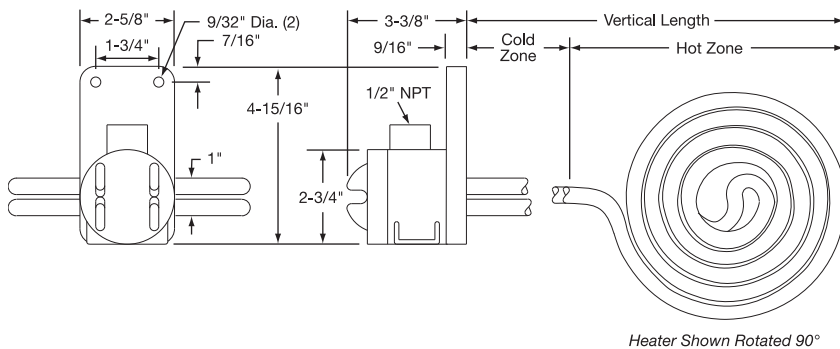

Note: Guards are recommended for all fluoropolymer heaters. Standard guards are made of polypropylene. Fluoropolymer (PTFE) guards are available for chromic acid and temperatures above 180°F (82°C).

Standard (Non-Stock) Sizes and Ratings with Polypropylene Guard

Watts	Part Number			Hot Zone		Vertical Length		Diameter	
	120V	240V	480V	in	mm	in	mm	in	mm
500	TMT03001	TMT03002	—	6	152	14	356	5	127
1000	TMT03003	TMT03004	—	7	178	14	356	6	152
2000	TMT03005	TMT03006	TMT03007	9	229	17	432	8	203
3000	—	TMT03008	TMT03009	10	254	23	584	9	229
4000	—	TMT03010	TMT03011	12	305	29	737	11	279
5000	—	TMT03012	TMT03013	13	330	35	889	12	305
6000	—	TMT03014	TMT03015	14	356	40	1016	13	330

Standard lead time is 2 to 3 weeks.

Ordering Information

See page 11-90

Fluoropolymer (PTFE) Single-Element L-Shaped Round Heater

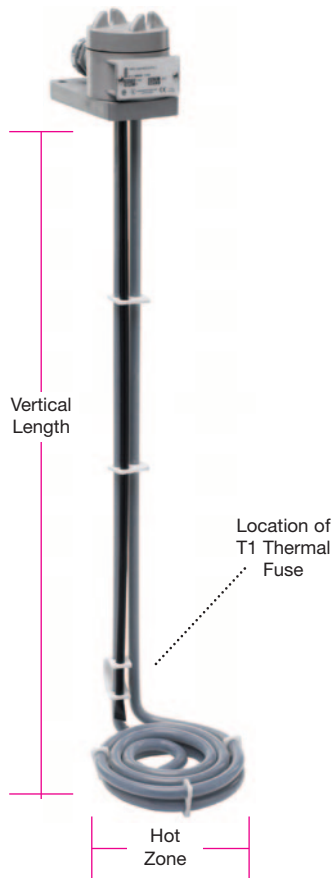

Typical Applications

Compatible with most plating tank solutions; inert to acids, anodizing and pickling solutions up to 190°F (88°C). Check compatibility guide on pages 11-88 and 11-89 and with chemical supplier for proper sheath material selection.

Replaces more expensive alumina or graphite heaters.

Design Features

- * Low profile bottom design for even heating and varying liquid levels
- * 10 watts/in² (1.6 watts/cm²) for long service life
- * Non-contaminating Fluoropolymer (PTFE) covered stainless steel elements
- * T1 thermal fuse protection standard; T2 bi-metal switch optional
- * Grounded internal metal element for safety
- * UL listed for US and Canada
- * Lightweight, non-floating construction
- * Vapor-tight polypropylene terminal enclosure with universal mounting flange
- * Standard 3-ft. flexible PVC liquid-tight conduit
- * Single-Phase only
- * 120, 240, 480 volts standard as listed — other voltages available
- * Longer and shorter vertical lengths available; consult Tempco

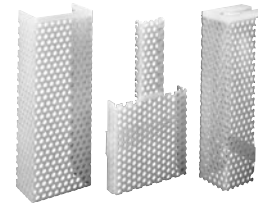
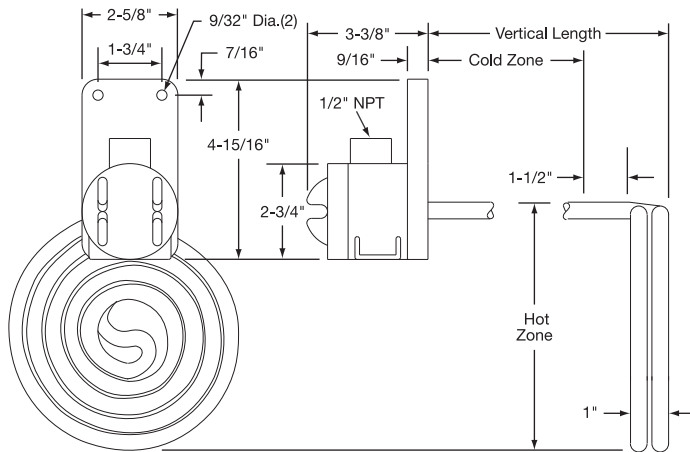

Note: Guards are recommended for all fluoropolymer heaters. Standard guards are made of polypropylene. Fluoropolymer (PTFE) guards are available for chromic acid and temperatures above 180°F (82°C).

Standard (Non-Stock) Sizes and Ratings with Polypropylene Guard

Watts	Part Number			Hot Zone		Vertical Length		Diameter	
	120V	240V	480V	in	mm	in	mm	in	mm
500	TMT04001	TMT04002	—	5	127	12	305	5	127
1000	TMT04003	TMT04004	—	6	152	12	305	6	152
2000	TMT04005	TMT04006	TMT04007	8	203	18	457	8	203
3000	—	TMT04008	TMT04009	9	229	18	457	9	229
4000	—	TMT04010	TMT04011	11	279	18	457	11	279
5000	—	TMT04012	TMT04013	12	305	18	457	12	305
6000	—	TMT04014	TMT04015	13	330	18	457	13	330

Standard lead time is 2 to 3 weeks.

Ordering Information

See page 11-90

Fluoropolymer (PTFE) Three-Element L-Shaped Heater

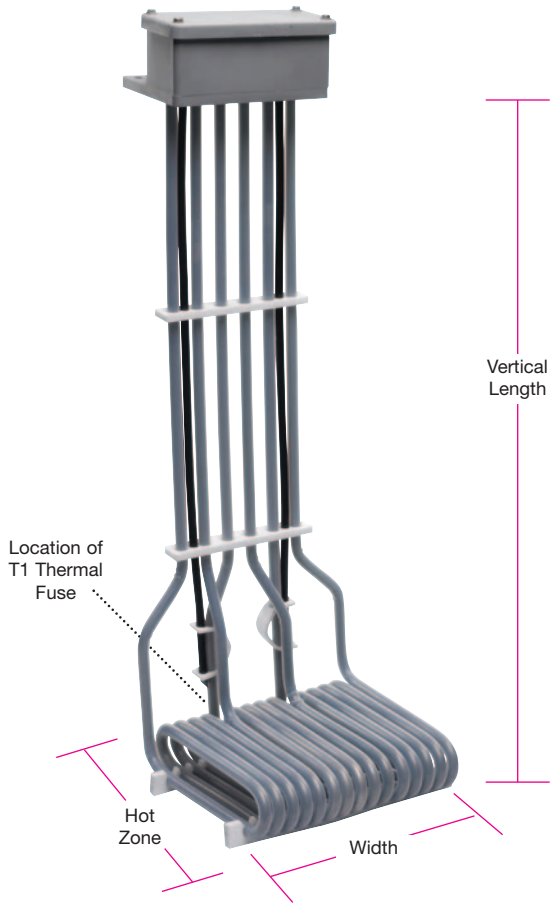

Typical Applications

Compatible with most plating tank solutions; inert to acids, anodizing and pickling solutions up to 190°F (88°C). Check compatibility guide on pages 11-88 and 11-89 and with chemical supplier for proper sheath material selection.

Replaces more expensive alumina or graphite heaters.

Design Features

- * Low profile bottom design for even heating and varying liquid levels
- * 10 watts/in² (1.6 watts/cm²) for long service life
- * Non-contaminating Fluoropolymer (PTFE) covered stainless steel elements
- * T1 thermal fuse protection standard; T2 bi-metal switch optional
- * Grounded internal metal element for safety
- * UL listed for US and Canada
- * Lightweight, non-floating construction
- * Vapor-tight polypropylene terminal enclosure with universal mounting bracket
- * Standard 3-ft. flexible PVC liquid-tight conduit
- * Standard three-phase wiring
- * 240, 480 volts standard as listed — other voltages available
- * Longer and shorter vertical lengths available; consult Tempco

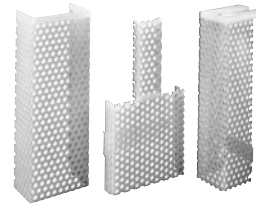
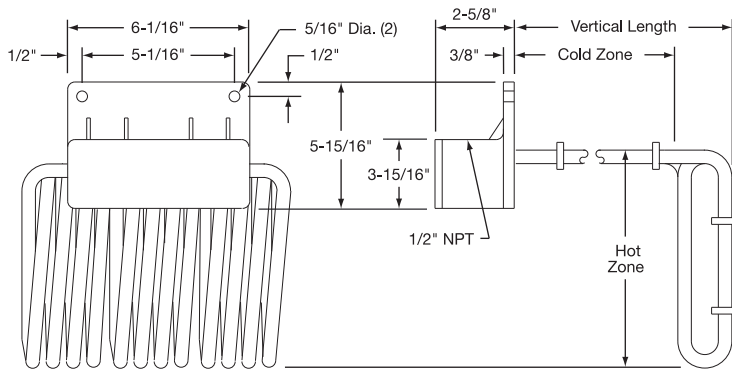

Note: Guards are recommended for all fluoropolymer heaters. Standard guards are made of polypropylene. Fluoropolymer (PTFE) guards are available for chromic acid and temperatures above 180°F (82°C).

Standard (Non-Stock) Sizes and Ratings with Polypropylene Guard

Watts	Part Number			Hot Zone		Vertical Length		Width	
	120V	240V	480V	in	mm	in	mm	in	mm
3000	—	TMT05001	TMT05002	13	330	18	457	8.0	203
6000	—	TMT05003	TMT05004	19	483	18	457	10.5	268
9000	—	TMT05005	TMT05006	23	584	18	457	10.5	268
12000	—	TMT05007	TMT05008	30	762	18	457	10.5	268
15000	—	TMT05009	TMT05010	36	914	18	457	10.5	268
18000	—	TMT05011	TMT05012	42	1067	18	457	10.5	268

Standard lead time is 2 to 3 weeks.

Ordering Information

See page 11-90

Fluoropolymer (PTFE) Three-Element Over-the-Side Heater

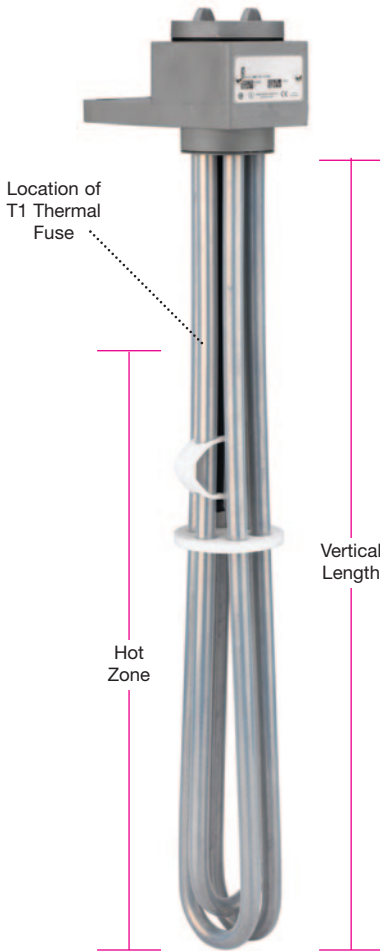

Typical Applications

Compatible with most plating tank solutions; inert to acids, anodizing and pickling solutions up to 190°F (88°C). Check compatibility guide on pages 11-88 and 11-89 and with chemical supplier for proper sheath material selection.

Replaces more expensive alumina or graphite heaters.

Design Features

- * 10 watts/in² (1.6 watts/cm²) for long service life
- * Non-contaminating Fluoropolymer (PTFE) covered stainless steel elements
- * T1 thermal fuse protection standard; T2 bi-metal switch optional
- * Grounded internal metal element for safety
- * UL listed for US and Canada
- * Lightweight, non-floating construction
- * Vapor-tight polypropylene terminal enclosure with universal mounting bracket
- * Standard 3-ft. flexible PVC liquid-tight conduit
- * Single-Phase for 120V, three-phase for 240V or 480V standard
- * 120, 240, 480 volts standard as listed — other voltages available
- * Longer lengths available; consult Tempco

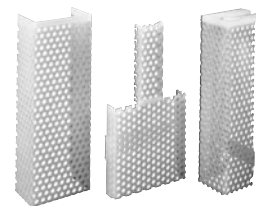

Note: Guards are recommended for all fluoropolymer heaters. Standard guards are made of polypropylene. Fluoropolymer (PTFE) guards are available for chromic acid and temperatures above 180°F (82°C).

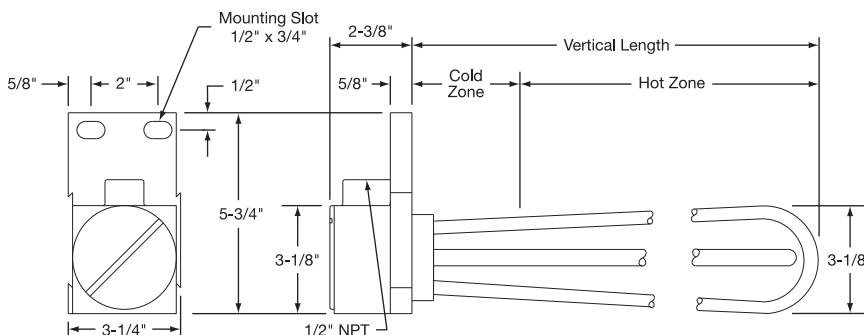

Standard (Non-Stock) Sizes and Ratings with Polypropylene Guard

Watts	Part Number			Hot Zone		Vertical Length	
	120V	240V	480V	in	mm	in	mm
1000	TMT06001	TMT06002	—	10	254	17	432
1500	TMT06003	TMT06004	TMT06005	16	406	23	584
2000	—	TMT06007	TMT06008	22	559	29	737
3000	—	TMT06009	TMT06010	29	737	35	889
4000	—	TMT06011	TMT06012	39	991	47	1194
5000	—	TMT06013	TMT06014	48	1219	59	1499
6000	—	TMT06015	TMT06016	56	1422	68	1727

Ordering Information
 See page 11-90

Standard lead time is 2 to 3 weeks.

Fluoropolymer (PTFE) Six-Element Over-the-Side Heater

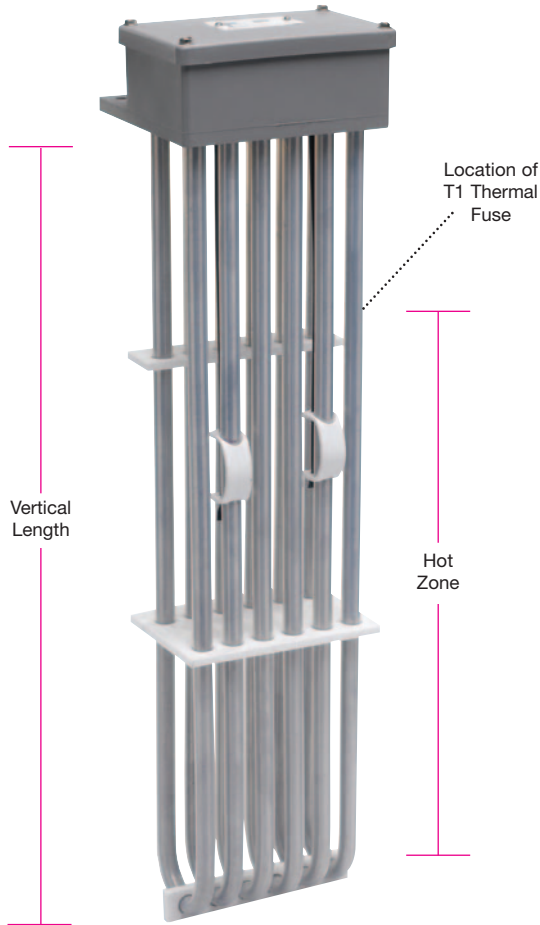

Typical Applications

Compatible with most plating tank solutions; inert to acids, anodizing and pickling solutions up to 190°F (88°C). Check compatibility guide on pages 11-88 and 11-89 and with chemical supplier for proper sheath material selection.

Replaces more expensive alumina or graphite heaters.

Design Features

- * 10 watts/in² (1.6 watts/cm²) for long service life
- * Non-contaminating Fluoropolymer (PTFE) covered stainless steel elements
- * T1 thermal fuse protection standard; T2 bi-metal switch optional
- * Grounded internal metal element for safety
- * UL listed for US and Canada
- * Lightweight, non-floating construction
- * Vapor-tight polypropylene terminal enclosure with universal mounting bracket
- * Standard 3-ft. flexible PVC liquid-tight conduit
- * Single-phase for 120V, three-phase for 240V or 480V standard
- * 120, 240, 480 volts standard as listed — other voltages available
- * Longer lengths available; consult Tempco

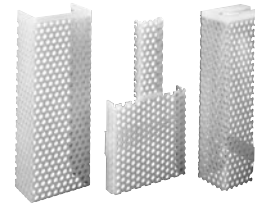
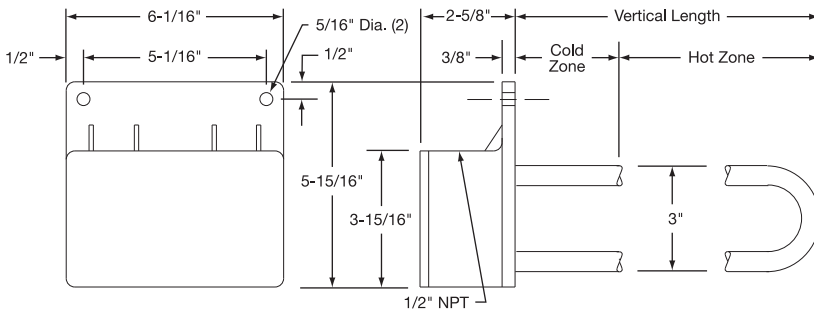

Note: Guards are recommended for all fluoropolymer heaters. Standard guards are made of polypropylene. Fluoropolymer (PTFE) guards are available for chromic acid and temperatures above 180°F (82°C).

Standard (Non-Stock) Sizes and Ratings with Polypropylene Guard

Watts	Part Number			Hot Zone		Vertical Length	
	120V	240V	480V	in	mm	in	mm
2000	TMT07001	TMT07002	TMT07003	9	229	17	432
3000	—	TMT07004	TMT07005	15	381	23	584
4000	—	TMT07006	TMT07007	21	533	29	737
6000	—	TMT07008	TMT07009	28	711	35	889
8000	—	TMT07010	TMT07011	38	965	47	1194
10000	—	TMT07012	TMT07013	47	1194	59	1499
12000	—	TMT07014	TMT07015	55	1397	68	1727

Standard lead time is 2 to 3 weeks.

Ordering Information

See page 11-90

Fluoropolymer (PTFE) Nine-Element Over-the-Side Heater

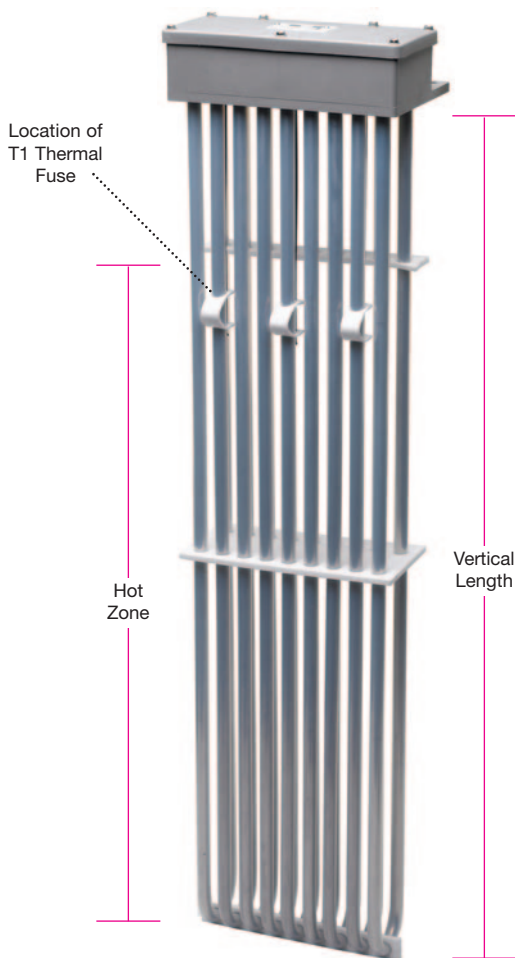

Typical Applications

Compatible with most plating tank solutions; inert to acids, anodizing and pickling solutions up to 190°F (88°C). Check compatibility guide on pages 11-88 and 11-89 and with chemical supplier for proper sheath material selection.

Replaces more expensive alumina or graphite heaters.

Design Features

- * 10 watts/in² (1.6 watts/cm²) for long service life
- * Non-contaminating Fluoropolymer (PTFE) covered stainless steel elements
- * T1 thermal fuse protection standard; T2 bi-metal switch optional
- * Grounded internal metal element for safety
- * UL listed for US and Canada
- * Lightweight, non-floating construction
- * Vapor-tight polypropylene terminal enclosure with universal mounting bracket
- * Standard 3-ft. flexible PVC liquid-tight conduit
- * Standard three-phase wiring
- * 240, 480 volts standard as listed — other voltages available
- * Longer lengths available; consult Tempco

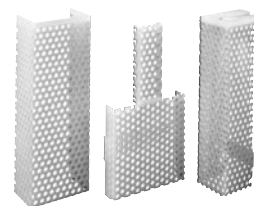

Note: Guards are recommended for all fluoropolymer heaters. Standard guards are made of polypropylene. Fluoropolymer (PTFE) guards are available for chromic acid and temperatures above 180°F (82°C).

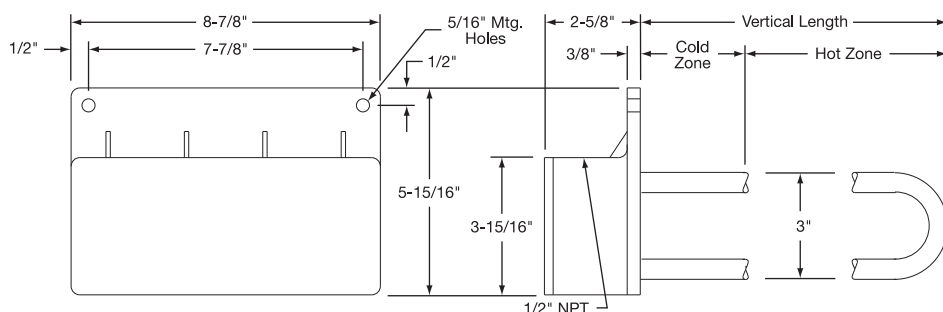

Standard (Non-Stock) Sizes and Ratings with Polypropylene Guard

Watts	Part Number			Hot Zone		Vertical Length	
	120V	240V	480V	in	mm	in	mm
3000	—	TMT08001	TMT08002	9	229	17	432
4500	—	TMT08003	TMT08004	15	381	23	584
6000	—	TMT08005	TMT08006	21	533	29	737
9000	—	TMT08007	TMT08008	28	711	35	889
12000	—	TMT08009	TMT08010	38	965	47	1194
15000	—	TMT08011	TMT08012	47	1194	59	1499
18000	—	TMT08013	TMT08014	55	1397	68	1727

Standard lead time is 2 to 3 weeks.

Ordering Information

See page 11-90

Tank Immersion Heaters

Metal Single-Tube Style Heater

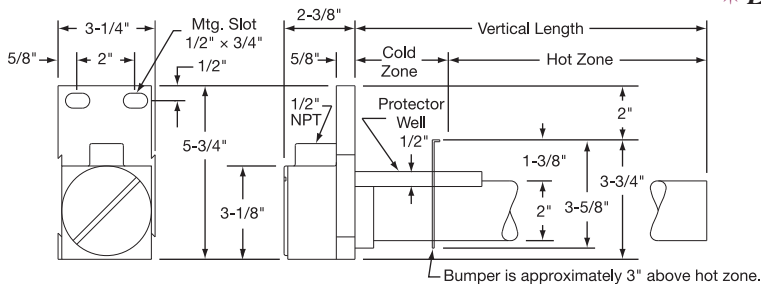
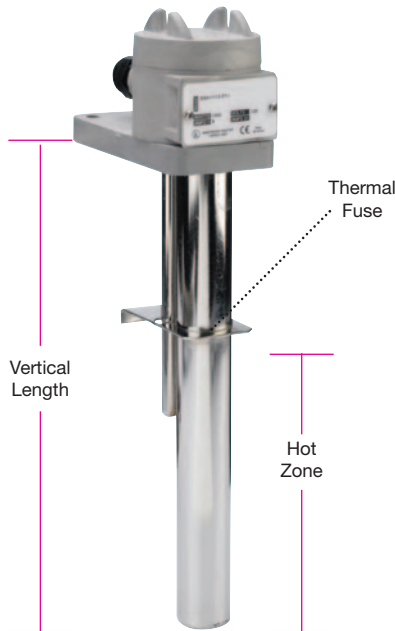

Typical Applications

For plating tanks, rinse tanks and other acidic aqueous solutions. Check compatibility guide on pages 11-88 and 11-89 and with chemical supplier for proper sheath material selection.

Design Features

- * 18 and 35 watts/in² (2.8 and 5.5 watts/cm²) for long service life
- * Heavy duty, long lasting construction
- * T1 thermal fuse protection standard; T2 bi-metal switch optional
- * Grounded for safety
- * UL listed except plain steel; for US and Canada
- * Vapor-tight polypropylene terminal enclosure with universal mounting bracket
- * Standard 3-ft. flexible PVC liquid-tight conduit
- * Single-Phase standard; three-phase available as an option
- * 120, 240, 480 volts standard as listed — other voltages available
- * Longer lengths available; consult Tempco

Standard Watts vs. Length and Hot Zone

Watts		Hot Zone		Length	
High	Low	in	mm	in	mm
1000	500	6	152	11	254
2000	1000	10	254	17	432
3000	1500	16	406	23	584
4000	2000	20	508	29	737
5000	2500	25	635	35	889
6000	3000	30	762	40	1016
8000	4000	37	940	47	1194
9000	4500	44	1118	54	1372
10000	5000	49	1245	59	1499
12000	6000	58	1473	68	1727

Standard lead time is 2 to 3 weeks.

Ordering Code: T M M 1

Type: TMM1

Length (in.)

Hot Zone (in.)

Watts ÷ 100

Phase: 1 or 3

Material
A – Steel
B – 304 SS
C – 316 SS
T – Titanium

Voltage
1 – 120
2 – 240
4 – 480

Thermal Over-Temperature Protection

Thermal Fuse

1L – Solutions up to 180°F
1M – Solutions from 180°F to 220°F
1H – Solutions from 220°F to 300°F

Bi-Metal Switch

2L – Solutions up to 180°F
2M – Solutions from 180°F to 220°F
2H – Solutions from 220°F to 300°F

Conduit Length (in.)
36" standard

Ordering Information

TMM1 heaters are offered with the options listed in this worksheet. Create an ordering code by filling in the blanks with the appropriate number and/or letter designation for your requirements, and a part number will be assigned.

WARNING: Cancer and Reproductive Harm - www.P65Warnings.ca.gov.

Metal Triple-Tube Style Heater

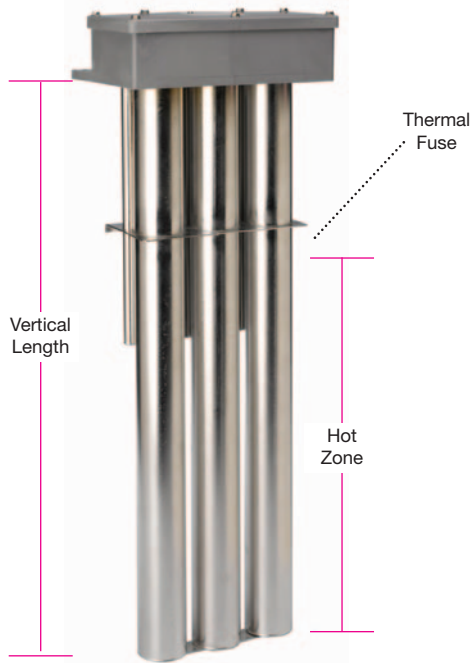

Typical Applications

For plating tanks, phosphatizing and concentrated aqueous solutions. Check compatibility guide on pages 11-88 and 11-89 and with chemical supplier for proper sheath material selection.

Design Features

- * 18 and 35 watts/in² (2.8 and 5.5 watts/cm²) for long service life
- * Low watt density for extended service
- * Heavy duty, long lasting construction
- * T1 thermal fuse protection standard; T2 bi-metal switch optional
- * Grounded for safety
- * UL listed except plain steel; for US and Canada
- * Vapor-tight polypropylene terminal enclosure with universal mounting bracket
- * Standard 3-ft. flexible PVC liquid-tight conduit
- * Standard design includes a common wiring terminal enclosure with a single conduit hub for external connections; power wiring from the three tubes can be configured single- or three-phase.
- * 120, 240, 480 volts standard as listed — other voltages available
- * Longer lengths available; consult Tempco

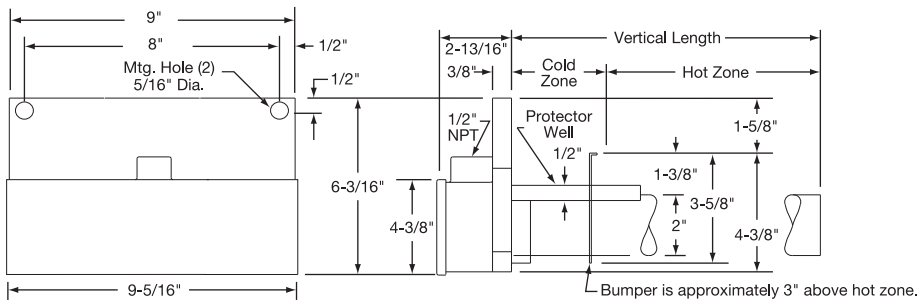

Standard Watts vs. Length and Hot Zone

Watts		Hot Zone		Length	
High	Low	in	mm	in	mm
3000	1500	6	152	11	254
6000	3000	10	254	17	432
9000	4500	16	406	23	584
12000	6000	20	508	29	737
15000	7500	25	635	35	889
18000	9000	30	762	40	1016
24000	12000	37	940	47	1194
27000	13500	44	1118	54	1372
30000	15000	49	1245	59	1499
36000	18000	58	1473	68	1727

Standard lead time is 2 to 3 weeks.

Ordering Code: T M M 2

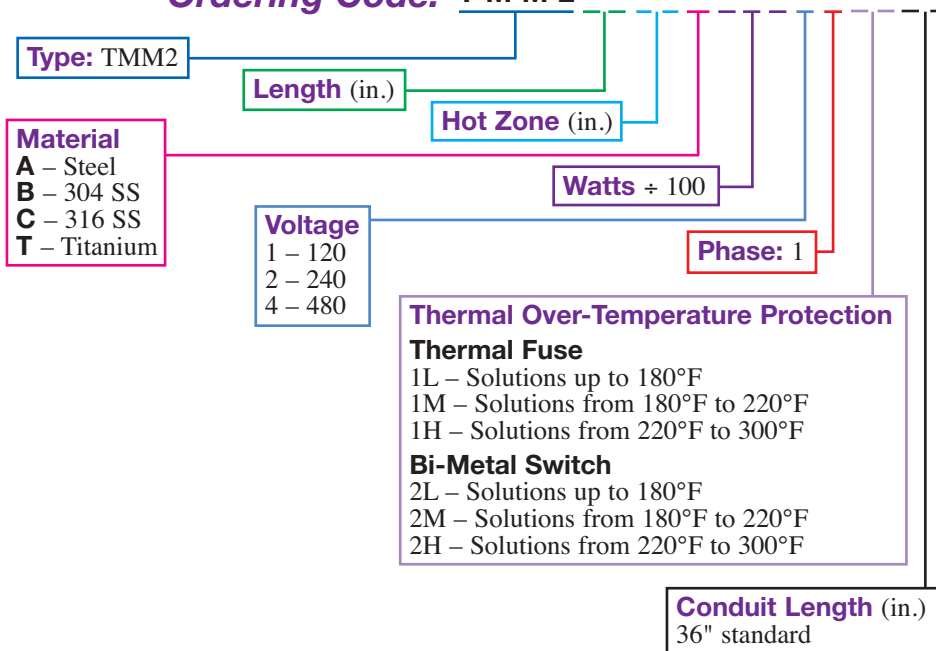

Ordering Information

TMM2 heaters are offered with the options listed in this worksheet. Create an ordering code by filling in the blanks with the appropriate number and/or letter designation for your requirements, and a part number will be assigned.

WARNING: Cancer and Reproductive Harm - www.P65Warnings.ca.gov

Metal Single-Tube L-Shaped Heater

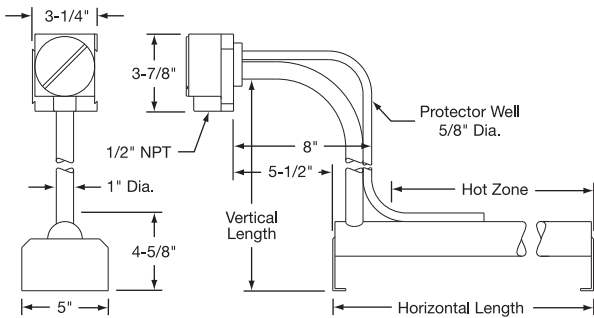
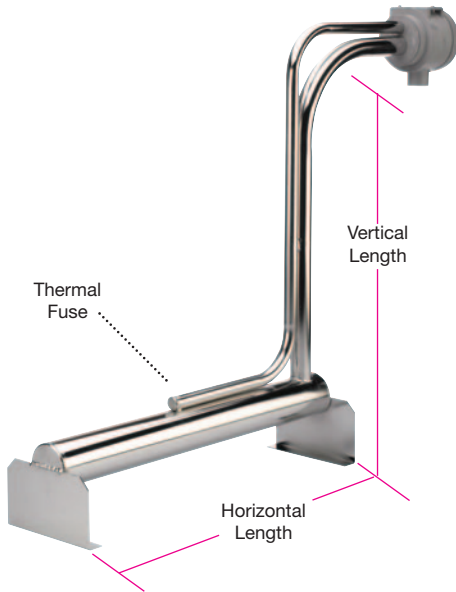

Typical Applications

For plating tanks, rinse tanks and other non-sludging aqueous solutions. Check compatibility guide on pages 11-88 and 11-89 and with chemical supplier for proper sheath material selection.

Design Features

- * 35 watts/in² (5.5 watts/cm²) for long service life
- * Bottom mount design for even heating and varying solution levels
- * Standard 2" sludge legs (longer available)
- * Heavy duty, long lasting construction
- * T1 thermal fuse protection standard; T2 bi-metal switch optional
- * Grounded for safety
- * UL listed except Plain Steel; for US and Canada
- * Vapor-tight polypropylene terminal enclosure
- * Standard 3-ft. flexible PVC liquid-tight conduit
- * Single-Phase standard; three-phase available as an option
- * 120, 240, 480 volts standard as listed — other voltages available
- * Longer and shorter vertical lengths available; consult Tempco

Standard Watts vs. Length

Watts	H. Length		V. Length	
	in	mm	in	mm
1000	13	330	15	381
2000	17	432	19	483
3000	22	559	25	635
4000	26	660	25	635
5000	31	787	37	940
6000	36	914	50	1270
8000	44	1118	50	1270
9000	50	1270	50	1270
10000	55	1397	50	1270
12000	64	1626	50	1270

Standard lead time is 2 to 3 weeks.

Ordering Code: T M M 3

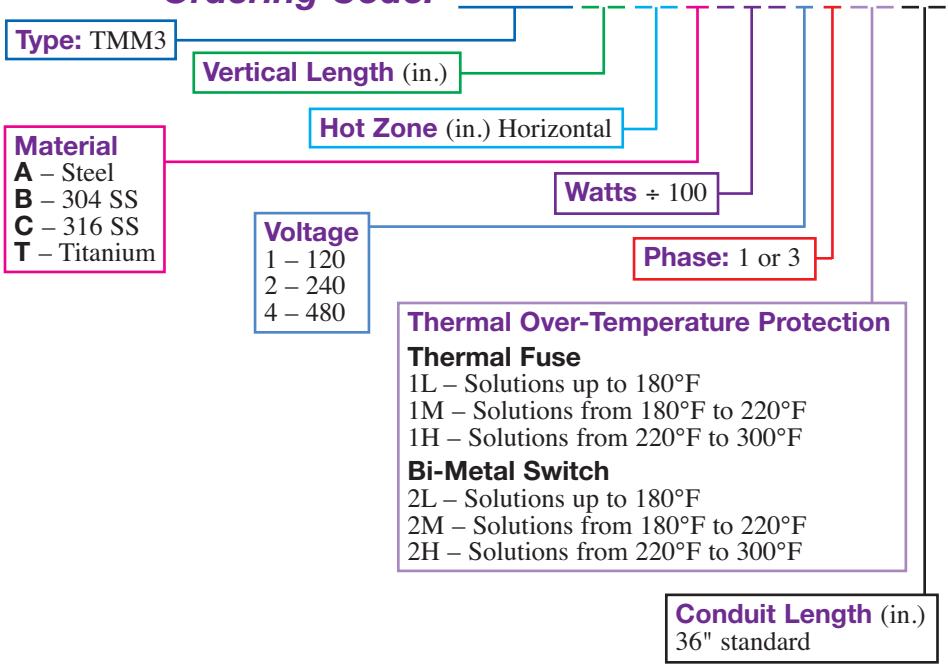

Ordering Information

TMM3 heaters are offered with the options listed in this worksheet. Create an ordering code by filling in the blanks with the appropriate number and/or letter designation for your requirements, and a part number will be assigned.

WARNING: Cancer and Reproductive Harm - www.P65Warnings.ca.gov.



Metal Triple-Tube L-Shaped Heater

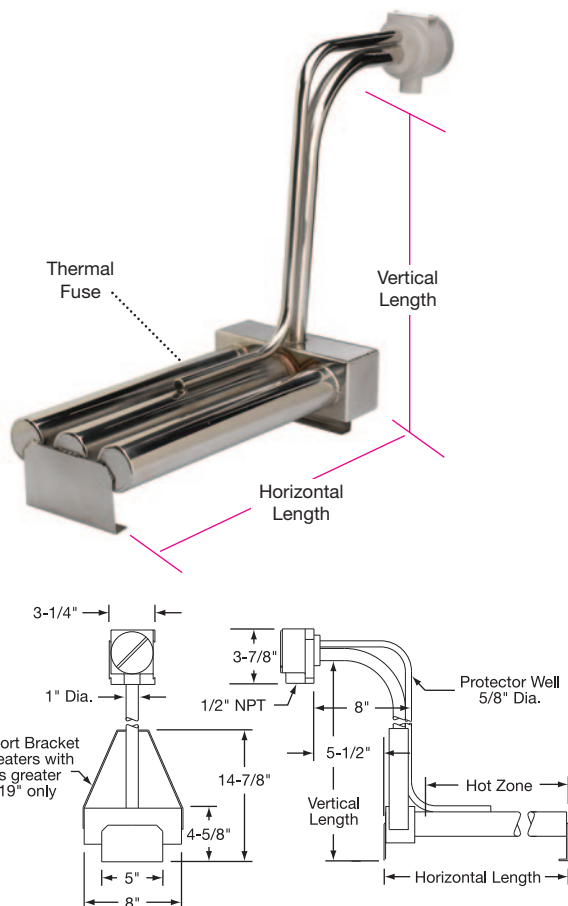

Typical Applications

For plating tanks, rinse tanks and other non-sludging aqueous solutions. Check compatibility guide on pages 11-88 and 11-89 and with chemical supplier for proper sheath material selection.

Design Features

- * 35 watts/in² (5.5 watts/cm²) for long service life
- * Bottom mount design for even heating and varying solution levels
- * Standard 2" sludge legs (longer available)
- * Heavy duty, long lasting construction
- * T1 thermal fuse protection standard; T2 bi-metal switch optional
- * Grounded for safety
- * UL listed except Plain Steel; for US and Canada
- * Vapor-tight polypropylene terminal enclosure
- * Standard 3-ft. flexible PVC liquid-tight conduit
- * Three-phase standard; single-phase available as option
- * 240, 480 volts standard as listed — other voltages available
- * Longer and shorter vertical lengths available; consult Tempco

Standard Watts vs. Length

Watts	H. Length		V. Length	
	in	mm	in	mm
3000	13	330	15	381
6000	17	432	37	940
9000	22	559	37	940
12000	26	660	37	940
15000	31	787	37	940
18000	36	914	50	1270
24000	44	1118	50	1270
27000	50	1270	50	1270
30000	55	1397	50	1270
36000	64	1626	50	1270

Standard lead time is 2 to 3 weeks.

Ordering Code: T M M 4

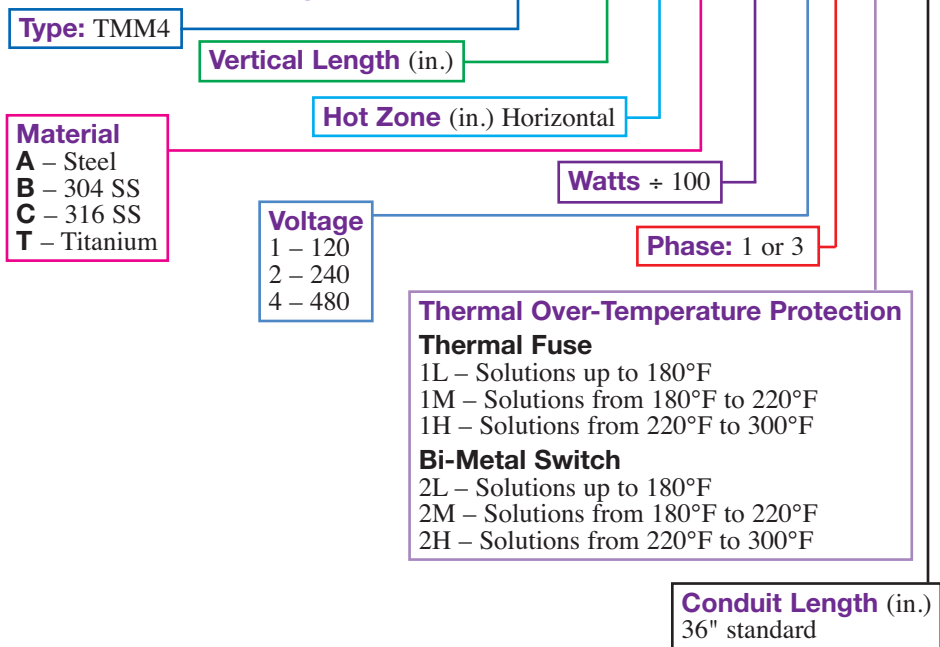

Ordering Information

TMM4 heaters are offered with the options listed in this worksheet. Create an ordering code by filling in the blanks with the appropriate number and/or letter designation for your requirements, and a part number will be assigned.

WARNING: Cancer and Reproductive Harm - www.P65Warnings.ca.gov.

Triple-Tube Vertical Stack L-Shape Heater

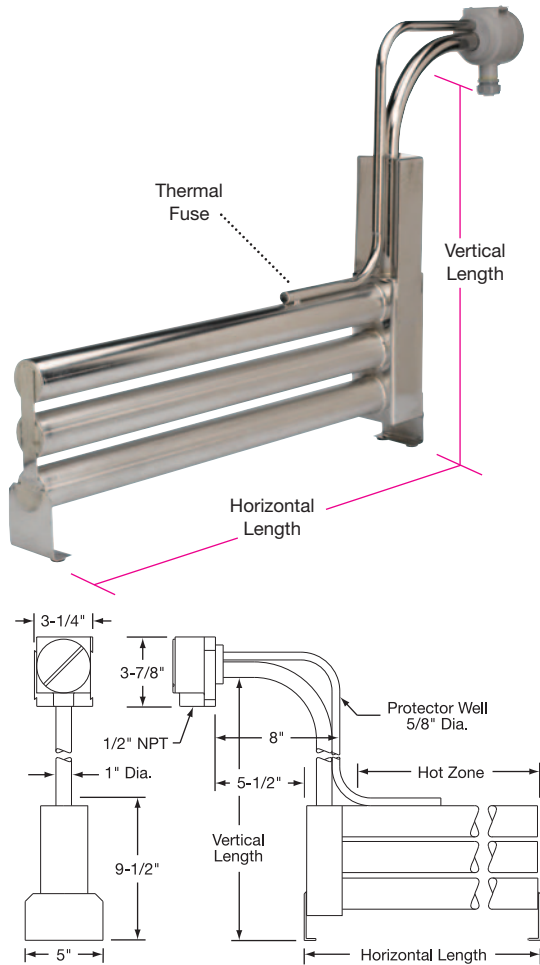

Typical Applications

For plating tanks, rinse tanks and other non-sludging aqueous solutions. Check compatibility guide on pages 11-88 and 11-89 and with chemical supplier for proper sheath material selection.

Design Features

- * 35 watts/in² (5.5 watts/cm²) for long service life
- * Space-saving vertical configuration
- * Bottom mount design for even heating and varying solution levels
- * Standard 2" sludge legs (longer available)
- * Heavy duty, long lasting construction
- * T1 thermal fuse protection standard; T2 bi-metal switch optional
- * Grounded for safety
- * UL listed except Plain Steel; for US and Canada
- * Vapor-tight polypropylene terminal enclosure
- * Standard 3-ft. flexible PVC liquid-tight conduit
- * Three-Phase standard; single-phase available as option
- * 240, 480 volts standard as listed — other voltages available
- * Longer and shorter vertical lengths available; consult Tempco

Standard Watts vs. Length

Watts	Hot Zone		V. Length	
	in	mm	in	mm
3000	13	330	19	483
6000	17	432	37	940
9000	22	559	37	940
12000	26	660	37	940
15000	31	787	37	940
18000	36	914	50	1270
24000	44	1118	50	1270
27000	50	1270	50	1270
30000	55	1397	50	1270
36000	64	1626	50	1270

Standard lead time is 2 to 3 weeks.

Ordering Code: T M M 5

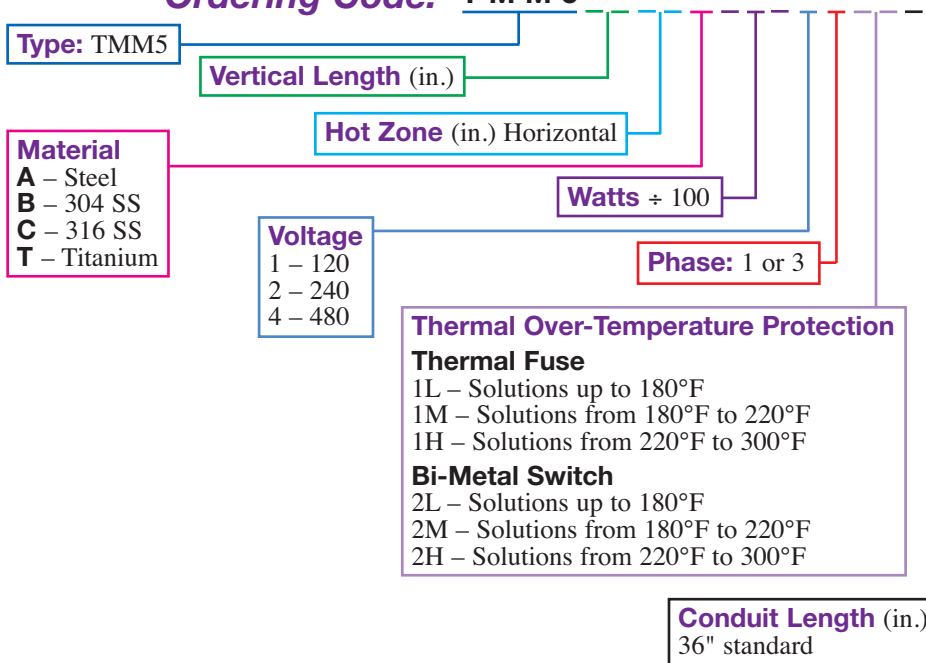

Type: TMM5

Vertical Length (in.)

Hot Zone (in.) Horizontal

Watts ÷ 100

Phase: 1 or 3

Voltage

1 - 120
2 - 240
4 - 480

Thermal Over-Temperature Protection

Thermal Fuse

1L - Solutions up to 180°F
1M - Solutions from 180°F to 220°F
1H - Solutions from 220°F to 300°F

Bi-Metal Switch

2L - Solutions up to 180°F
2M - Solutions from 180°F to 220°F
2H - Solutions from 220°F to 300°F

Conduit Length (in.)

36" standard

Ordering Information

TMM5 heaters are offered with the options listed in this worksheet. Create an ordering code by filling in the blanks with the appropriate number and/or letter designation for your requirements, and a part number will be assigned.

WARNING: Cancer and Reproductive Harm - www.P65Warnings.ca.gov.

Quartz Single and Triple-Tube Style Heaters

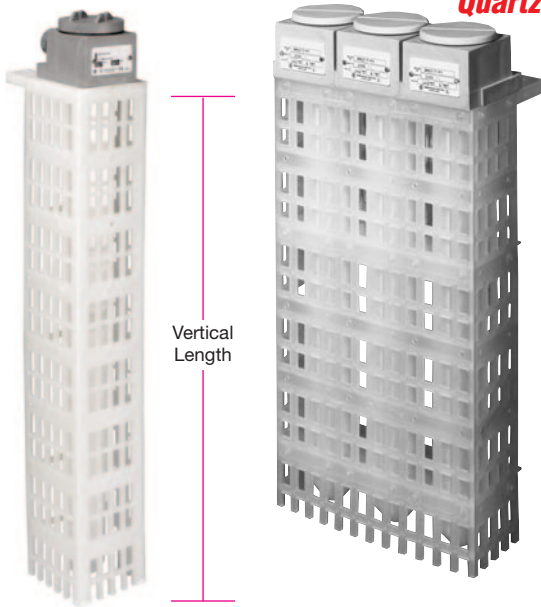

Design Features

- * 26 watts/in² (4.0 watts/cm²) for long service life
- * Heavy duty, long lasting construction
- * T1 thermal fuse protection standard; T2 bi-metal switch optional
- * Replaceable element and quartz tube
- * Grounded for safety
- * UL listed up to 4 KW/assembly for US and Canada
- * Vapor-tight polypropylene terminal enclosure with universal mounting bracket
- * Standard 3-ft. flexible PVC liquid-tight conduit
- * Standard guards are made of polypropylene. Fluoropolymer (PTFE) guards are available for chromic acid and temperatures above 180°F (82°C).
- * KMH1 Single-Phase standard; three-phase available as an option
- * KMH3 consists of three individual single-phase heaters, which can be wired delta in the field to achieve a three-phase balanced operating system; individual elements are field replaceable
- * 120, 240, 480 volts standard as listed—other voltages available
- * Longer lengths available; consult Tempco

Typical Applications

For plating tanks, pickling and other acidic aqueous solutions. Check compatibility guide on pages 11-88 and 11-89 and with chemical supplier for proper sheath material selection.



Not for use in hydrofluoric acid or alkaline solutions.

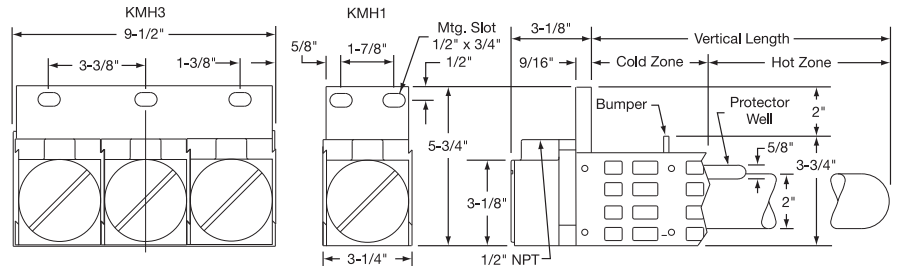

Ordering Code: K M H

Type: KMH1 or KMH3

Length (in.) _____

Hot Zone (in.) _____

Voltage
1 – 120
2 – 240
4 – 480

Watts ÷ 100 _____

Phase: 1 or 3

Thermal Over-Temperature Protection

Thermal Fuse	Bi-Metal Switch
1L – Solutions up to 180°F	2L – Solutions up to 180°F
1M – Solutions from 180°F to 220°F	2M – Solutions from 180°F to 220°F

Conduit Length (in.)
36" standard

Style
C – Complete Assembly
H – Less Guard
E – Element Only
J – Tube Only

Standard Watts vs. Length and Hot Zone

KMH1 Watts	KMH3 Watts	Hot Zone in	Hot Zone mm	Length in	Length mm
500	1500	6	152	10	254
1000	3000	7	178	11	279
1000	3000	7	178	17	432
2000	6000	12	305	17	432
2000	6000	12	305	23	584
3000	9000	18	457	23	584
3000	9000	18	457	29	737
3500	11500	21	533	29	737
4000	12000	28	711	35	889
4000	12000	28	711	41	1041
5000	15000	33	838	41	1041
5000	15000	33	838	47	1194
6000	18000	39	991	47	1194
6000	18000	39	991	52	1321
8000	24000	49	1245	59	1499
10000	30000	62	1575	71	1803

Standard lead time is 2 to 3 weeks.

Ordering Information

KMH1 and KMH1 heaters are offered with the options listed in this worksheet. Create an ordering code by filling in the blanks with the appropriate number and/or letter designation for your requirements, and a part number will be assigned.

WARNING: Cancer and Reproductive Harm - www.P65Warnings.ca.gov.

Custom Process Tubular DUCT Forced Air Heaters

Process air duct heaters are used for tempering forced air in many industrial processes. Heater wattage is dependent on air outlet temperature (up to 1200°F [650°C]) and air velocity. Smaller duct heaters can be tandem mounted in place of one large unit to meet space limitations and simplify installation.

Heavy wall Incoloy® tubular heating elements (field replaceable) provide protection against corrosive air environments and resistance to vibration when compared to open coil elements.

Air duct heaters can be designed specifically for high pressure and/or hazardous locations. Turnkey systems including the duct heater, power and temperature control panel, and the temperature and over-temperature sensors can also be provided.

Our creative team of professionals can design and manufacture your next process forced air duct heating system.

Consult us with Your Requirements.

Typical Applications

- ↪ Air Drying/Curing Operations
- ↪ Annealing
- ↪ Autoclaves
- ↪ Booster Air Heater
- ↪ Braking Resistor
- ↪ Core Drying
- ↪ Dehumidification
- ↪ Forced Air Comfort Heating
- ↪ Heat Treating
- ↪ Make-Up Air Heating
- ↪ Re-Heating
- ↪ Resistor Load Banks



Electrical Housings: NEMA 4 (moisture resistant), NEMA 7 (explosion resistant) and NEMA 12 (dust resistant) are available.

High Temperature Application:
The electrical housing is separated from the heater flange to lower the ambient temperature of the electrical wiring.



Finned Duct Heaters
See Page 11-113A



Element Configuration: Elements can be U-bends, W-bends and foldback design depending on the requirements of the application.

Selection and Sizing
See Page 11-107

Installation and Wiring
See Page 11-111

Standard Designs
See Page 11-113

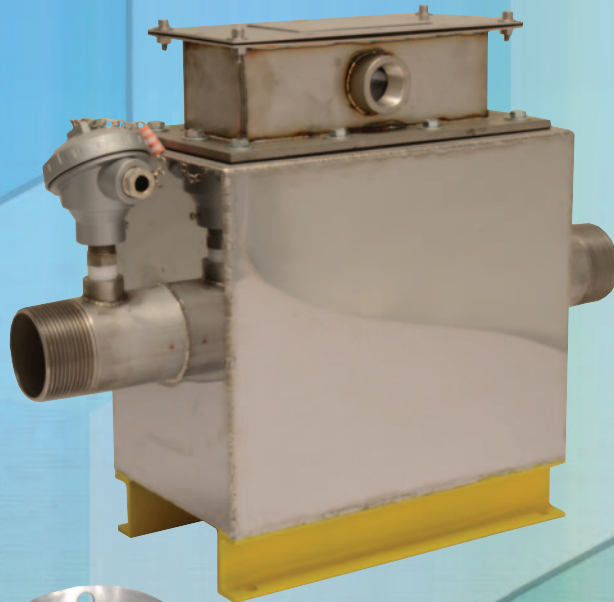

Custom Designs

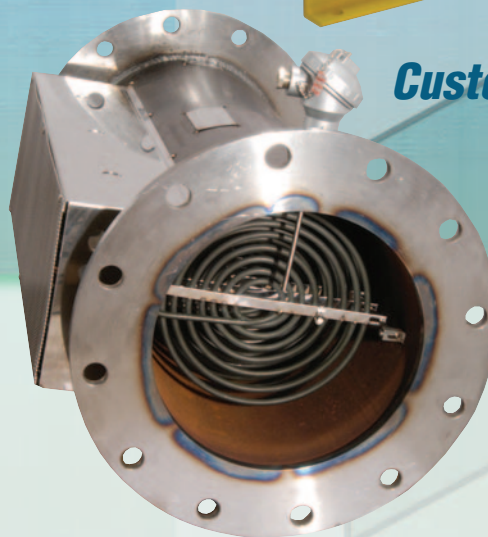

Duct Heater System: Tempco can supply the heater and blower assembled, ready for connection to the application duct work. The pictured 48KW, 480V unit produces 1500 CFM of heated air to dry metal parts after being coated with a rust inhibitor.

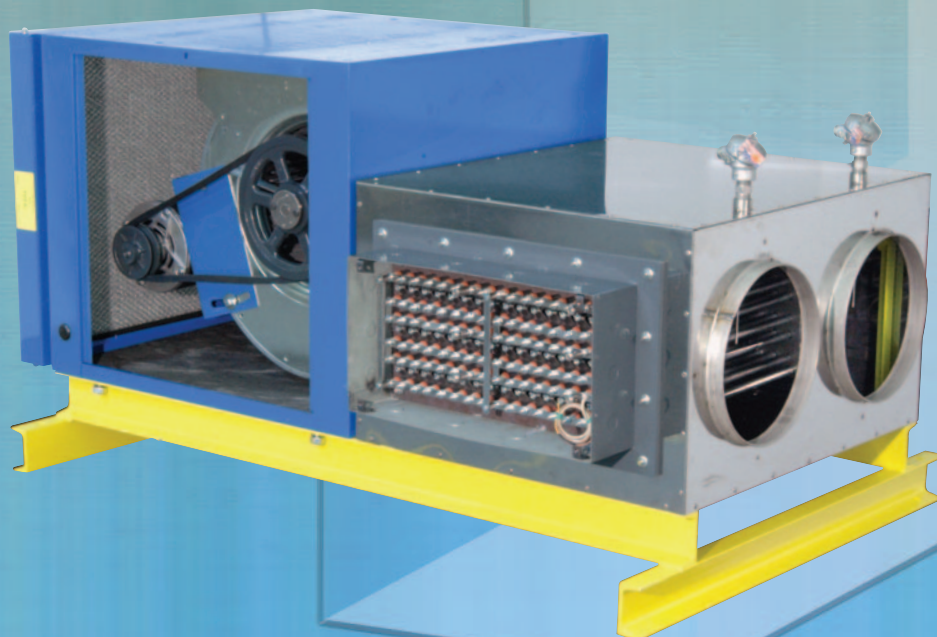

Complete Your Thermal Loop System with a Tempco Power/Temperature Control Panel.
See pages 13-56 through 13-63.

(800) 323-6859 • Email: sales@tempco.com

Duct Heaters

Forced Air Tubular and Finned Tubular Duct Heaters

A NEMA 1 terminal box enclosure with vented cover to help keep wiring cooler. Optional enclosures: NEMA 4 (moisture resistant), NEMA 7 (explosion resistant) and NEMA 12 (dust resistant).

B 3-1/2 inches (89 mm) of mineral insulation in a stainless steel enclosure below the mounting flange, minimizes heat losses while keeping the electrical wiring cooler.

C The heavy duty frame is composed of a 1/4 inch (6 mm) thick steel mounting flange, stainless steel support plate and corner posts to securely hold the heating elements rigid in any mounting position.

Standard Features

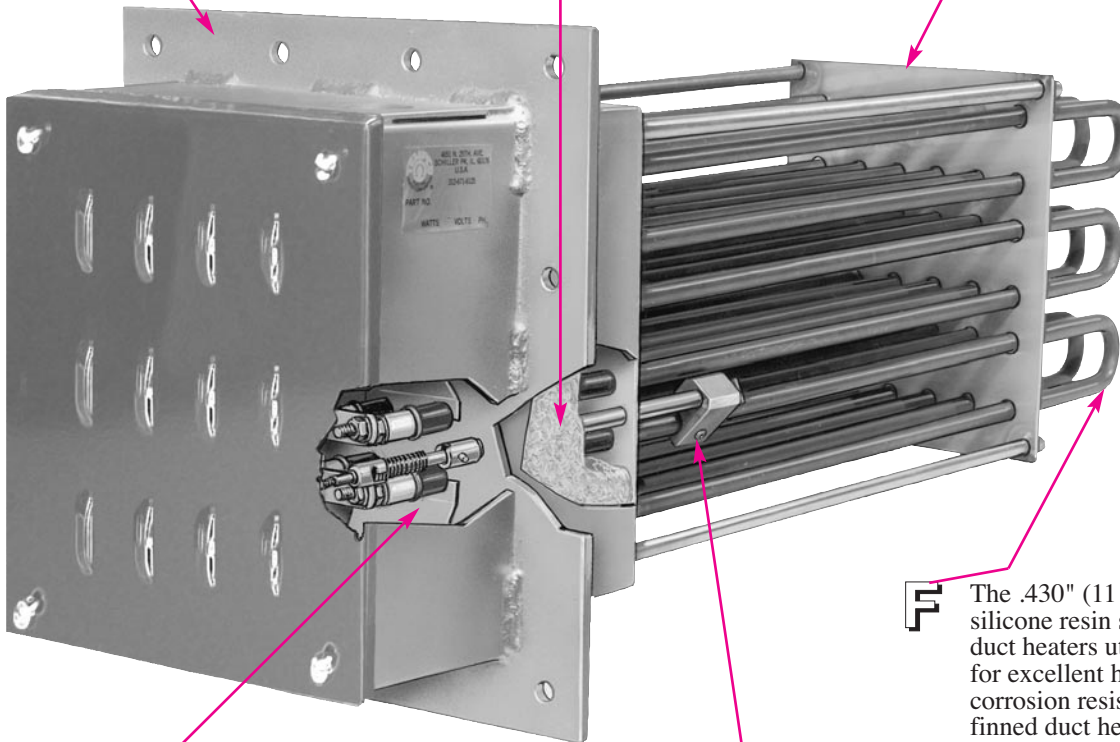

Finned Duct Heater

D Standard field replaceable elements are held in place with single-screw quick-release "V" clamps. Pressure resistant designs utilizing welded elements, bulkhead fittings, or compression fittings to attach elements to the flange are available to limit leakage of ducted air or gases into the terminal enclosure. Welded elements are used for gas tight applications.

E A 9/32" (7 mm) inside diameter thermowell accessed through a 1/8" NPT tapped hole in the flange allows installation of an optional Type J or K thermocouple for sensing temperature within the element bundle. It can be clamped directly to an element for use as a high limit providing a faster response. An excellent safeguard for your system.

F The .430" (11 mm) diameter elements are silicone resin sealed. High temperature tubular duct heaters utilize Incoloy® sheath material for excellent high temperature scaling and corrosion resistance. The medium temperature finned duct heaters have stainless steel fins on a corrosion resistant stainless steel sheath. High temperature Incoloy® elements have all bends repressed in special dies to recompact the MgO refractory to eliminate any electrical insulation voids and hot spots.

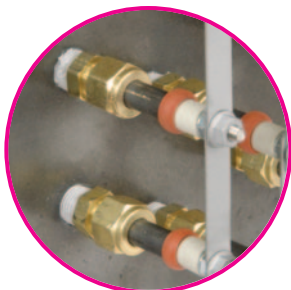

Compression Fittings

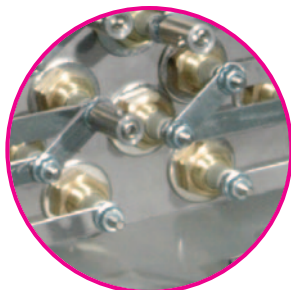

Bulkhead Fittings



Duct Heaters have been certified as Recognized Components by Underwriters Laboratories (File Number E90771) to meet UL standard 1030, and CSA certified to meet Canadian Standard C22.2, No 72 and 88 (File Number 043099).

These files specify end use limitations and conditions of acceptability for the use of this type of heater. For additional information consult Tempco.

If you require UL, CSA, or other NRTL Agency Approvals, please specify when ordering.

Checklist — Selecting a High Temperature Tubular Duct Heater

✓ Sizing the Duct Heater

To properly match a duct heater to an application, the wattage, air velocity and element watt density must be determined.

Formulas and graphs on the following pages that will aid you in your design include:

- Wattage calculation formulas and table
- Element Watt Density vs. Sheath Temperature and Air Velocity Graph
- Pressure Drop vs. Air Velocity Graph

In most applications the following design limitations should be adhered to:

- Maximum watt density of 40 watts/in² (6.2 watts/cm²)
- Maximum element sheath temperature of 1400°F (760°C)
- Minimum air velocity of 200 feet per minute (61 meters per minute)
- Maximum voltage for UL certified heaters is 480V.
- Maximum voltage for CSA certified heaters is 600V.

✓ Calculating Minimum Wattage Requirement

Calculating Minimum Wattage Requirement

Table is for quick-estimation purposes and is based on air under standard conditions (70°F inlet air temperature at 14.7 PSIA).



Note: If air flow is given in CFM at operating temperature and pressure it can be converted to SCFM (Standard Cubic Feet per Minute) with the following formula (use the equations to the right for compressed air):

$$SCFM = CFM \times \frac{P}{14.7} \times \frac{530}{T + 460}$$

P = operating pressure (gauge pressure + 14.7)

T = operating temperature

Remember when calculating wattage to use the maximum anticipated air flow and to compensate for any heat losses.

For free air use equations:

$$KW = \frac{SCFM \times \text{Temperature rise } (^\circ F)}{3000}$$

or

$$KW = \frac{SCMM \times \text{Temperature rise } (^\circ C)}{47}$$

For compressed air use equations:

$$KW = \frac{CFM^* \times \text{Density}^* (\text{lbs/cu. ft.}) \times \text{Temperature rise } (^\circ F)}{228}$$

or

$$KW = \frac{CMM^* \times \text{Density}^* (\text{kgs/cu. m}) \times \text{Temperature rise } (^\circ C)}{57.5}$$

*At heater inlet temperature and pressure

Note: The free air equations include a 6% safety factor.

KWH to Heat Air at Selected Flow Rates

Amt. of Air CFM	Temperature Rise (°F)											
	50	100	150	200	250	300	350	400	450	500	600	
100	1.7	3.3	5	6.7	8.3	10	11.7	13.3	15	16.7	20	
200	3.3	6.7	10	13.3	16.7	20	23.3	26.7	30	33.3	40	
300	5.0	10.0	15	20.0	25.0	30	35.0	40.0	45	50.0	60	
400	6.7	13.3	20	26.7	33.3	40	46.7	53.3	60	66.7	80	
500	8.3	16.7	25	33.3	41.7	50	58.3	66.7	75	83.3	100	
600	10.0	20.0	30	40.0	50.0	60	70.0	80.0	90	100.0	120	
700	11.7	23.3	35	46.7	58.3	70	81.7	93.3	105	116.7	140	
800	13.3	26.7	40	53.3	66.7	80	93.3	106.7	120	133.3	160	
900	15.0	30.0	45	60.0	75.0	90	105.0	120.0	135	150.0	180	
1000	16.7	33.3	50	66.7	83.3	100	116.7	133.3	150	166.7	200	
1100	18.3	36.7	55	73.3	91.7	110	128.3	146.7	165	183.3	220	
1200	20.0	40.0	60	80.0	100.0	120	140.0	160.0	180	200.0	240	



Note: For additional information or help with your application please consult TEMPCO.

Checklist – Selecting the Proper Duct Heater, *continued*

Element Watt Density vs. Air Temperature and Air Velocity

Use graph (English or Metric) to plot

Outlet Air Temperature vs. Outlet Air Velocity to determine Element Watt Density

The recommended watt density is based on a maximum element sheath temperature of 1400°F (760°C). Air and other gases that are poor conductors of heat require watt densities matched to the velocity of the gas flow to prevent element overheating. Selecting a lower watt density for the heating elements will extend heater life expectancy.

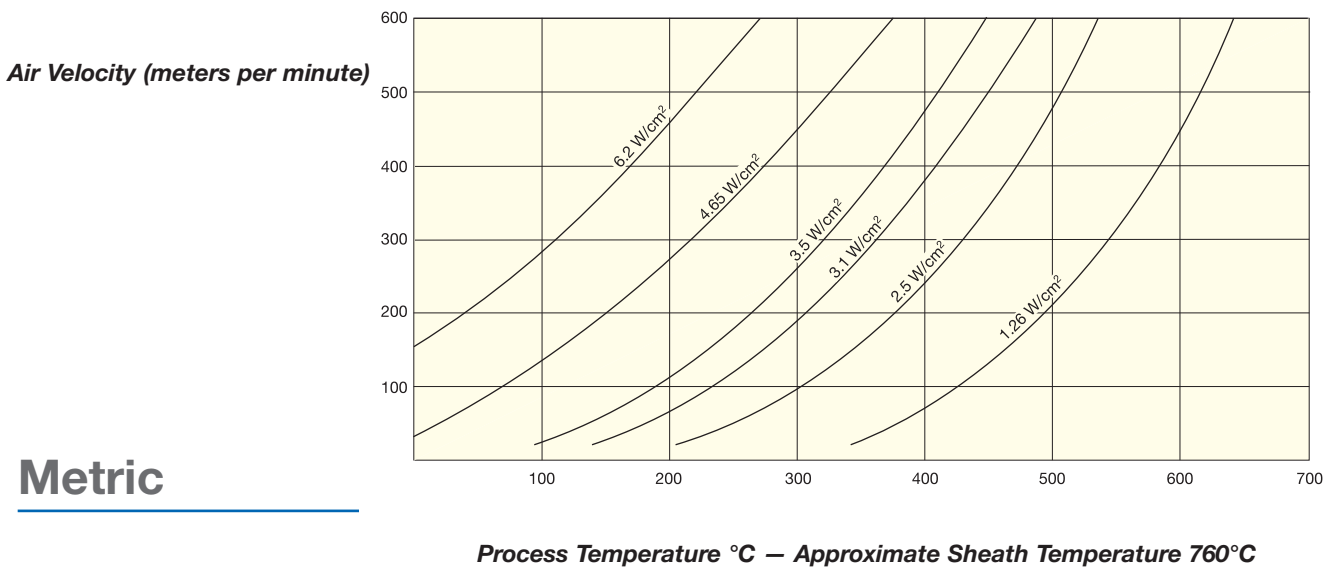
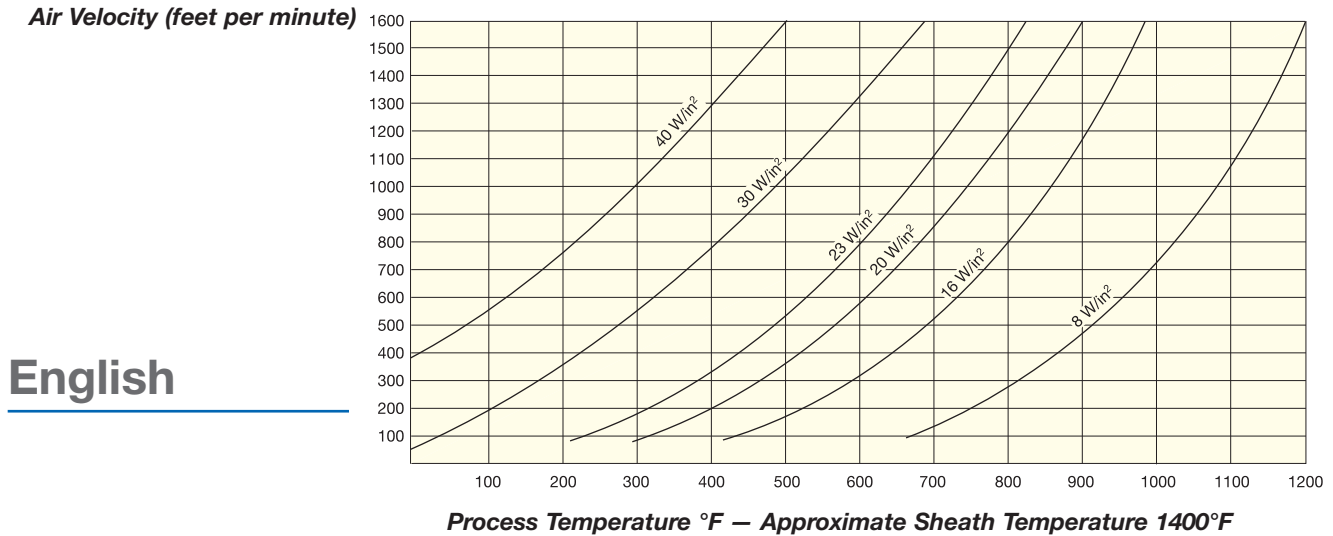

Element Watt Density is the wattage dissipated per square inch of the element sheath surface and is calculated with the following formula.

$$\text{Watt Density} = \frac{\text{element wattage}}{\pi \times \text{element dia.} \times \text{element heated length}}$$

Checklist — Selecting the Proper Duct Heater, *continued*

Element Watt Density vs. Sheath Temperature and Air Velocity

Use graph (English or Metric) to plot

Watt Density vs. Air Velocity to determine Sheath Temperature

or

Watt Density vs. Sheath Temperature to determine the required Air Velocity

English

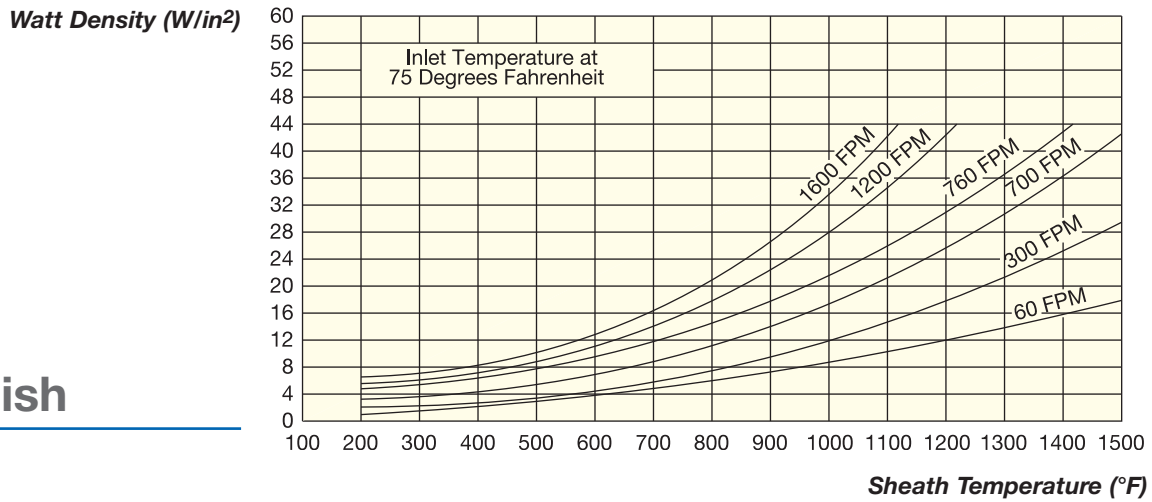

Metric

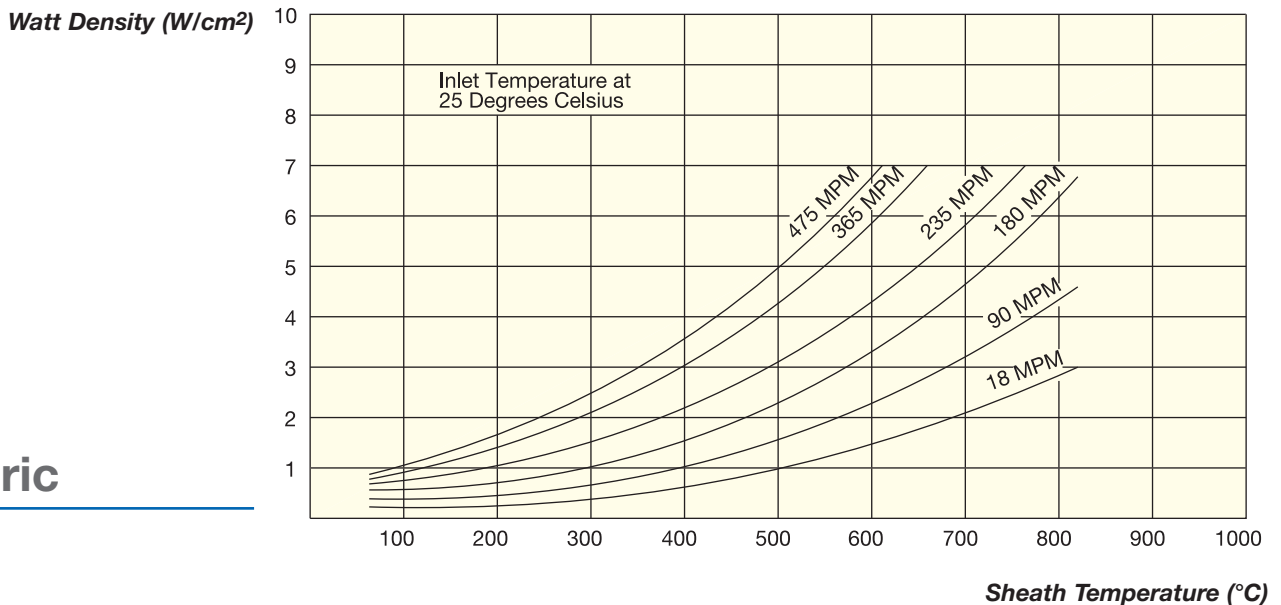

Checklist — Selecting the Proper Duct Heater, *continued*

Pressure Drop vs. Air Velocity

Use graph (English or Metric) to plot

Pressure Drop vs. Air Velocity for standard duct heaters sizes used to properly Size Blowers

Air Velocity (feet per minute)

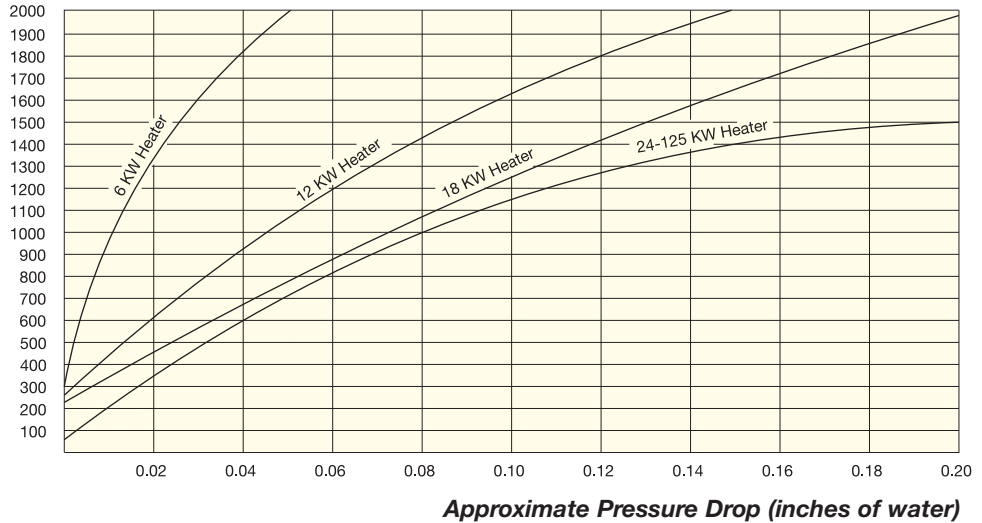

English

Calculating Air Velocity

$$\text{Velocity (feet/minute)} = \frac{\text{SCFM (CFM measured at standard conditions)}}{\text{Duct cross sectional area at heater in square feet}}$$

Air Velocity (meters per minute)

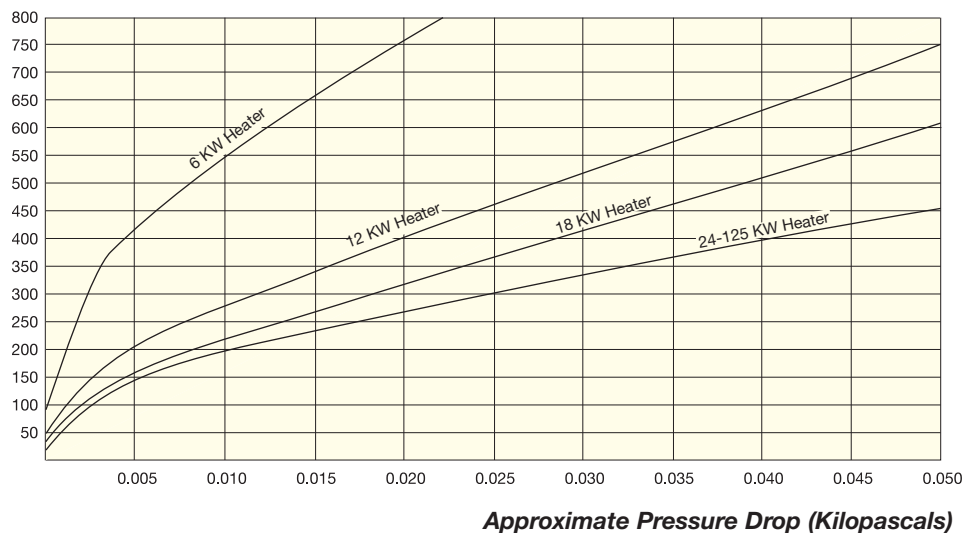

Metric

Duct Heater Installation Recommendations

Installation Recommendations

1. Tempco Duct Heaters may be bolted to the ductwork through the side, bottom or top. Bottom and side mounting are preferred to minimize wiring/terminal enclosure temperatures.
2. Before mounting, consideration should be given to the strength of the ductwork required to support the weight of the heater. Add additional hangers or supports as required.
3. The inlet side of the unit should be at least 48 inches downstream from any change in duct size or duct direction.
4. To minimize pressure drop, mount the duct with the narrow width of the heater perpendicular to the air flow.
5. Duct heaters may be mounted in tandem to increase the KW that can be installed.
6. Process temperature sensing should be located downstream from the duct heater.
7. Air flows must never be interrupted. Such events will cause overheating and/or premature heater burnout. Your installation should include high limit temperature controls. All standard duct heaters have a thermowell attached to one element for installing a thermocouple to sense element temperature. Additional protection for the heater from low air flow can be achieved by installing an air flow switch or pressure switch on the inlet side.
8. Select the terminal housing that provides the best terminal protection from the environment surrounding the application.



Wiring

1. Power supply conductors must have a minimum ampacity of 125% of the maximum heater load and be rated for the ambient temperature of the heater enclosure.
2. The air handler should run on a time delay after the heater is de-energized. This allows the elements to cool without overheating adjacent areas.
3. Duct heaters drawing more than 48 Amps are divided into smaller branch circuits, each drawing 48 Amps or less. Please note that the number of circuits, can be changed to accommodate any wiring requirements you may have.



Note: Before you proceed to make any changes on factory prewired heaters, check the heater wiring schematic or consult Tempco.

All electrical wiring must be done in accordance with national and local electrical codes.



Maintenance Recommendations

1. Never perform any type of service on duct heaters prior to disconnecting all power supply lines.
2. After long periods of idle use, clean elements prior to start-up.
3. Periodically clean the elements even during regular use so as not to allow dirt to build up on the elements.
4. Periodically check that mounting screws or bolts have not become loose from blower vibration.
5. Periodically check that electrical connections are clean and tight.
6. Failed elements are field replaceable, minimizing downtime and saving the cost of a complete new heater.

Standard Duct Heater Features

Design Features

- * NEMA 1 General Purpose Ventilated Enclosure
- * Painted Steel Mounting Flange
- * Single- and Three-Phase Wiring
- * 3-1/2" (89 mm) Insulation
- * Field Replaceable Incoloy® 840 Elements
- * Element Bends Re-pressed
- * 1/4" (6 mm) Inside Diameter Thermowell
- * Stainless Steel Support Plate and Corner Posts

Typical Installation

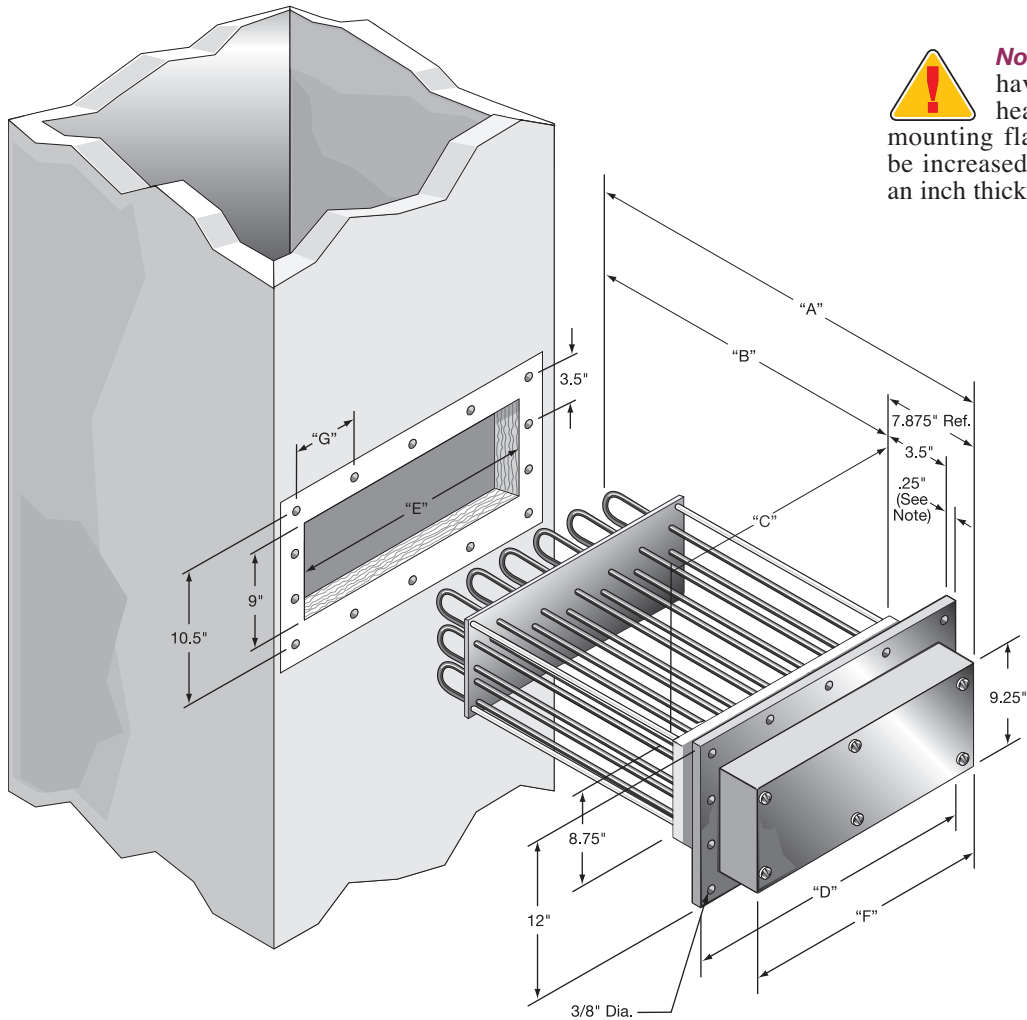

Standard (Non-Stock) Duct Heater Construction Specifications

Dimensions Reference Number	"A"		"B"		"C"		"D"		"E"		"F"		"G"		Number of Elements	Approximate Net Weight	
	in	mm	in	mm	in	mm	in	mm	in	mm	in	mm	in	mm		lbs	kgs
1	27 ⁷ / ₈	708	20	508	2 ³ / ₄	70	6 ¹ / ₂	165	3	76	3 ³ / ₈	92	2 ¹ / ₂	64	6	22	10
2	27 ⁷ / ₈	708	20	508	4 ³ / ₄	121	8 ¹ / ₂	216	5	127	5 ⁵ / ₈	143	3 ¹ / ₂	89	12	31	14
3	27 ⁷ / ₈	708	20	508	6 ³ / ₄	171	10 ¹ / ₂	267	7	178	7 ⁷ / ₈	194	3	76	18	41	19
4	27 ⁷ / ₈	708	20	508	8 ³ / ₄	222	12 ¹ / ₂	318	9	229	9 ⁵ / ₈	244	2 ³ / ₄	70	24	51	23
5	27 ⁷ / ₈	708	20	508	10 ³ / ₄	273	14 ¹ / ₂	368	11	279	11 ¹ / ₈	295	3 ¹ / ₄	83	30	62	28
6	27 ⁷ / ₈	708	20	508	12 ³ / ₄	324	16 ¹ / ₂	419	13	330	13 ³ / ₈	346	3 ³ / ₄	95	36	73	33
7	27 ⁷ / ₈	708	20	508	14 ³ / ₄	375	18 ¹ / ₂	470	15	381	15 ⁵ / ₈	397	4 ¹ / ₄	108	42	84	38
8	27 ⁷ / ₈	708	20	508	16 ³ / ₄	425	20 ¹ / ₂	521	17	432	17 ⁵ / ₈	448	4 ³ / ₄	121	48	95	43
9	27 ⁷ / ₈	708	20	508	18 ³ / ₄	476	22 ¹ / ₂	572	19	483	19 ⁵ / ₈	498	5 ¹ / ₄	133	54	106	48
10	27 ⁷ / ₈	708	20	508	20 ³ / ₄	527	24 ¹ / ₂	622	21	533	21 ³ / ₈	549	5 ³ / ₄	146	60	117	53
11	32 ⁷ / ₈	835	25	635	20 ³ / ₄	527	24 ¹ / ₂	622	21	533	21 ⁵ / ₈	549	5 ³ / ₄	146	60	130	59
12	40 ³ / ₈	1026	32 ¹ / ₂	826	20 ³ / ₄	527	24 ¹ / ₂	622	21	533	21 ⁵ / ₈	549	5 ³ / ₄	146	60	155	70
13	49 ⁷ / ₈	1254	41 ¹ / ₂	1054	20 ³ / ₄	527	24 ¹ / ₂	622	21	533	21 ⁵ / ₈	549	5 ³ / ₄	146	60	180	82

Finned Duct Heaters

Design Features

- * NEMA 1 General Purpose Ventilated Enclosure
- * Stainless Steel Mounting Flange and Terminal Box
- * Single- and Three-Phase Wiring
- * 1" (25 mm) Insulation
- * Field Replaceable .430 Diameter Stainless Steel Elements
- * 9/32" (7 mm) ID Sensor Thermowell
- * Stainless Steel Support Plate and Corner Posts
- * Stainless Steel Insulation Housing

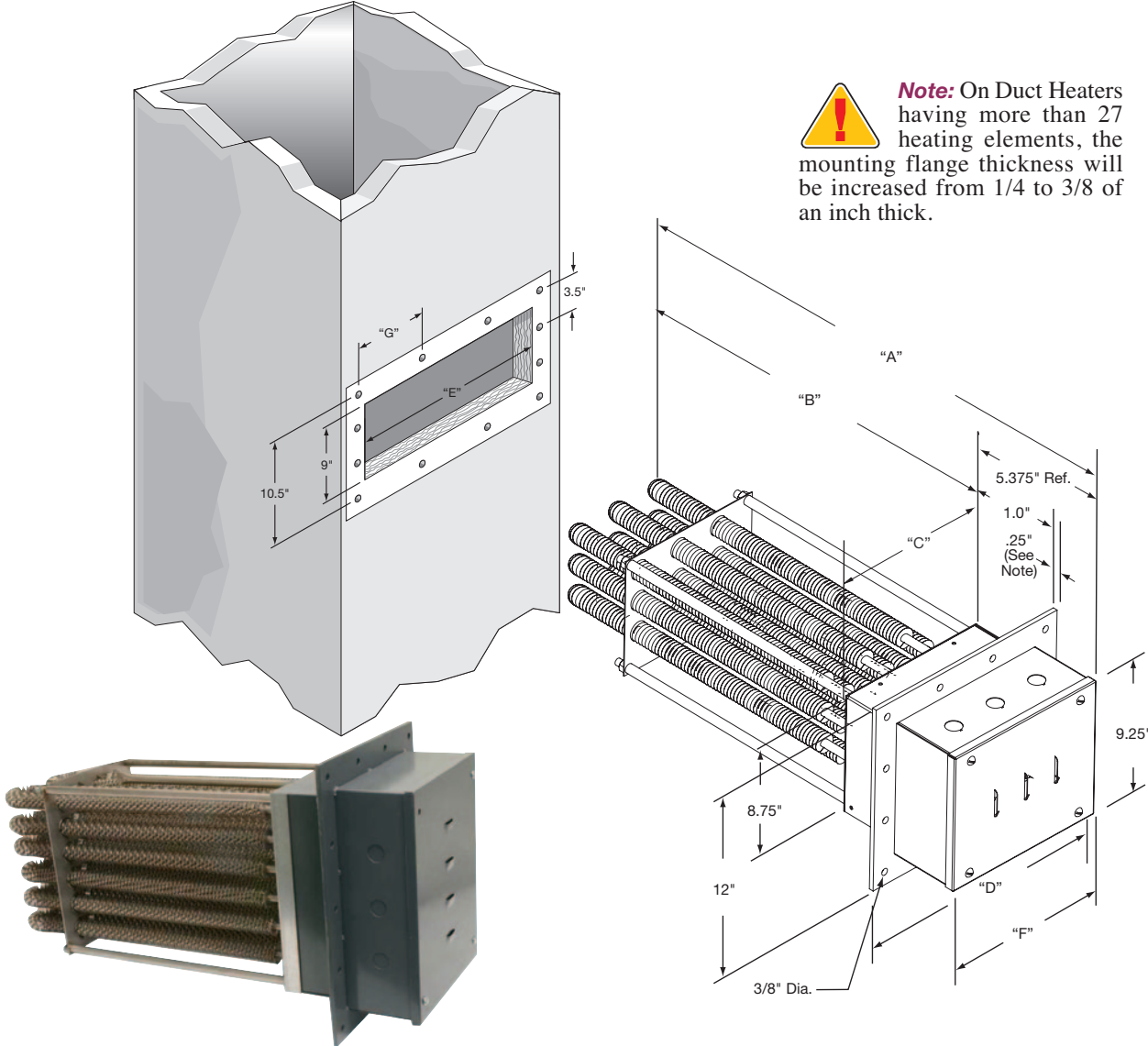

Standard (Non-Stock) Duct Heater Construction Specifications

Dimensions Reference Number	"A"		"B"		"C"		"D"		"E"		"F"		"G"		Number of Elements	Approximate Net Weight	
	in	mm	in	mm	in	mm	in	mm	in	mm	in	mm	in	mm		lbs	kgs
1	25 ³ / ₈	645	20	508	3 ¹ / ₄	95	7	177.8	4	102	4 ¹ / ₄	108	2 ³ / ₄	70	3	22	10
2	25 ³ / ₈	645	20	508	6 ¹ / ₄	159	9 ¹ / ₂	241	6.5	165	6 ³ / ₄	171	4	102	6	31	14
3	25 ³ / ₈	645	20	508	8 ³ / ₄	222	12	305	9	229	9 ¹ / ₄	235	3 ¹ / ₂	89	9	41	19
4	25 ³ / ₈	645	20	508	11 ³ / ₄	298	14 ¹ / ₂	368	12	305	11 ³ / ₄	298	3 ¹ / ₄	83	12	51	23
5	25 ³ / ₈	645	20	508	13 ³ / ₄	349	17	432	14	356	14 ¹ / ₄	362	3 ³ / ₈	98	15	62	28
6	25 ³ / ₈	645	20	508	16 ¹ / ₄	413	19 ¹ / ₂	495	16.5	419	16 ³ / ₄	425	4 ¹ / ₂	114	18	73	33
7	25 ³ / ₈	645	20	508	18 ³ / ₄	476	22	559	19	483	19 ¹ / ₄	489	4 ³ / ₈	105	21	84	38
8	25 ³ / ₈	645	20	508	21 ³ / ₄	552	24 ¹ / ₂	622	22	559	21 ³ / ₄	552	4 ⁷ / ₈	117	24	95	43
9	25 ³ / ₈	645	20	508	23 ³ / ₄	603	27	686	24	610	24 ¹ / ₄	616	5 ¹ / ₈	130	27	106	48
10	25 ³ / ₈	645	20	508	26 ¹ / ₄	679	29 ¹ / ₂	749	27	686	26 ³ / ₄	679	5 ³ / ₈	143	30	117	53
11	30 ¹ / ₄	768	24 ⁷ / ₈	632	26 ³ / ₄	679	29 ¹ / ₂	749	27	686	26 ³ / ₄	679	5 ³ / ₈	143	30	130	59
12	37 ¹ / ₄	946	31 ⁷ / ₈	810	26 ³ / ₄	679	29 ¹ / ₂	749	27	686	26 ³ / ₄	679	5 ³ / ₈	143	30	155	70
13	45	1143	39 ³ / ₈	1006	26 ³ / ₄	679	29 ¹ / ₂	749	27	686	26 ³ / ₄	679	5 ³ / ₈	143	30	180	82



Standard (Non-Stock) Finned Tubular Duct Heaters

Watt Density		Dimensions Reference Number	Part Number			Part Number			
W/in ²	W/cm ²		240V-1Ph (C*)	240V-3Ph (C*)	Replacements Elements	480V-1 Ph (C*)	480V-3 Ph (C*)	Replacements Elements	
42	6.5	6	1	FDH01002 (1)	FDH01003 (1)	THF00706	FDH01004 (1)	FDH01005 (1)	THF00707
		12	2	FDH01006 (1)	FDH01007 (1)	THF00706	FDH01008 (1)	FDH01009 (1)	THF00707
		18	3	FDH01010 (2)	FDH01011 (1)	THF00706	FDH01012 (1)	FDH01013 (1)	THF00707
		24	4	FDH01014 (2)	FDH01015 (2)	THF00706	FDH01016 (1)	FDH01017 (1)	THF00707
		30	5	—	FDH01018 (2)	THF00706	FDH01019 (2)	FDH01020 (1)	THF00707
		36	6	—	FDH01021 (2)	THF00706	FDH01022 (2)	FDH01023 (1)	THF00707
		42	7	—	FDH01024 (2)	THF00706	FDH01025 (2)	FDH01026 (1)	THF00707
		48	8	—	FDH01027 (4)	THF00706	FDH01028 (2)	FDH01029 (2)	THF00707
		54	9	—	FDH01030 (3)	THF00706	FDH01031 (3)	FDH01032 (2)	THF00707
		60	10	—	FDH01033 (4)	THF00706	FDH01034 (4)	FDH01035 (2)	THF00707
		75	11	—	FDH01036 (4)	THF00710	FDH01037 (4)	FDH01038 (2)	THF00711
		100	12	—	—	—	—	FDH01039 (4)	THF00714
		125	13	—	—	—	—	FDH01040 (4)	THF00716
62	9.6	9	1	FDH01041 (1)	FDH01042 (1)	THF00708	FDH01043 (1)	FDH01044 (1)	THF00709
		18	2	FDH01045 (2)	FDH01046 (1)	THF00708	FDH01047 (1)	FDH01048 (1)	THF00709
		27	3	FDH01049 (3)	FDH01050 (2)	THF00708	FDH01051 (2)	FDH01052 (1)	THF00709
		36	4	—	FDH01053 (2)	THF00708	FDH01054 (2)	FDH01055 (1)	THF00709
		45	5	—	FDH01056 (5)	THF00708	FDH01057 (2)	FDH01058 (2)	THF00709
		54	6	—	FDH01059 (3)	THF00708	FDH01060 (3)	FDH01061 (2)	THF00709
		63	7	—	FDH01062 (7)	THF00708	FDH01063 (3)	FDH01064 (2)	THF00709
		72	8	—	FDH01065 (4)	THF00708	FDH01066 (4)	FDH01067 (2)	THF00709
		81	9	—	FDH01068 (6)	THF00708	FDH01069 (6)	FDH01070 (3)	THF00709
		90	10	—	FDH01071 (5)	THF00708	FDH01072 (4)	FDH01073 (4)	THF00709
		115	11	—	FDH01074 (10)	THF00712	FDH01075 (5)	FDH01076 (4)	THF00713
		150	12	—	—	—	—	FDH01077 (4)	THF00715
		190	13	—	—	—	—	FDH01078 (5)	THF00717

(C*) = Number of Branch Circuits per heater (48 amps each branch max). For different circuit wiring configurations consult Tempco.

The 42 watt/sq.in. heaters are rated for outlet air temperatures up to 475°F at a minimum 1000 SFPM inlet air velocity.

The 62 watt/sq.in. heaters are rated for outlet air temperatures up to 500°F at a minimum 1750 SFPM air velocity.

Heaters are designed for ambient air heating at a nominal inlet temperature range of 60°- 100°F.

Inlet air temperature should not exceed 300°F.

Maximum recommended sheath operating temperature is 1000°F. If a higher temperature is needed, an unfinned alloy sheath TDH unit should be used.

Ordering Information

Catalog Heaters

Order by catalog number for catalog heaters.

Standard lead time is 3 to 4 weeks.

Note that Replacement Element Part Numbers for each heater are also listed.

Custom Engineered/Manufactured Heaters

For sizes and ratings not listed, **TEMPCO** will design and manufacture a Duct Heater to meet your requirements. Specify if UL or CSA approval required.

Please Specify the following:

- | | | |
|---|--|---|
| <input type="checkbox"/> Duct size | <input type="checkbox"/> Element watt density | <input type="checkbox"/> Over-temperature thermocouple, if required |
| <input type="checkbox"/> Air flow velocity | <input type="checkbox"/> Element sheath material | <input type="checkbox"/> UL or CSA approval |
| <input type="checkbox"/> Inlet and outlet temperature | <input type="checkbox"/> Mounting flange material | <input type="checkbox"/> Any other modifications |
| <input type="checkbox"/> Wattage, voltage and phase | <input type="checkbox"/> Insulation thickness | |
| <input type="checkbox"/> Number of circuits | <input type="checkbox"/> Electrical enclosure type | |

⚠ WARNING: Cancer and Reproductive Harm - www.P65Warnings.ca.gov.



Standard (Non-Stock) Duct Heaters

Watt Density W/in ² W/cm ²	KW	Dimensions Reference Number	Part Number			Part Number		
			240V-1Ph (C*)	240V-3Ph (C*)	Replacement Elements	480V-1 Ph (C*)	480V-3 Ph (C*)	Replacement Elements
20 3.1	6	1	TDH01002 (1)	TDH01003 (1)	THE03405	TDH01004 (1)	TDH01005 (1)	THE03819
	12	2	TDH01006 (1)	TDH01007 (1)	THE03405	TDH01008 (1)	TDH01009 (1)	THE03819
	18	3	TDH01010 (2)	TDH01011 (1)	THE03405	TDH01012 (1)	TDH01013 (1)	THE03819
	24	4	TDH01014 (2)	TDH01015 (2)	THE03405	TDH01016 (1)	TDH01017 (1)	THE03819
	30	5	—	TDH01018 (2)	THE03405	TDH01019 (2)	TDH01020 (1)	THE03819
	36	6	—	TDH01021 (2)	THE03405	TDH01022 (2)	TDH01023 (1)	THE03819
	42	7	—	TDH01024 (2)	THE03405	TDH01025 (2)	TDH01026 (1)	THE03819
	48	8	—	TDH01027 (4)	THE03405	TDH01028 (2)	TDH01029 (2)	THE03819
	54	9	—	TDH01030 (3)	THE03405	TDH01031 (3)	TDH01032 (2)	THE03819
	60	10	—	TDH01033 (4)	THE03405	TDH01034 (4)	TDH01035 (2)	THE03819
	75	11	—	TDH01036 (4)	THE03845	TDH01037 (4)	TDH01038 (2)	THE03846
	100	12	—	—	—	—	TDH01039 (4)	THE03847
	125	13	—	—	—	—	TDH01040 (4)	THE03848
30 4.7	9	1	TDH01072 (1)	TDH01073 (1)	THE03849	TDH01074 (1)	TDH01075 (1)	THE03851
	18	2	TDH01076 (2)	TDH01077 (1)	THE03849	TDH01078 (1)	TDH01079 (1)	THE03851
	27	3	TDH01080 (3)	TDH01081 (2)	THE03849	TDH01082 (2)	TDH01083 (1)	THE03851
	36	4	—	TDH01084 (2)	THE03849	TDH01085 (2)	TDH01086 (1)	THE03851
	45	5	—	TDH01087 (5)	THE03849	TDH01088 (2)	TDH01089 (2)	THE03851
	54	6	—	TDH01090 (3)	THE03849	TDH01091 (3)	TDH01092 (2)	THE03851
	63	7	—	TDH01093 (7)	THE03849	TDH01094 (3)	TDH01095 (2)	THE03851
	72	8	—	TDH01096 (4)	THE03849	TDH01097 (4)	TDH01098 (2)	THE03851
	81	9	—	TDH01099 (6)	THE03849	TDH01100 (6)	TDH01101 (3)	THE03851
	90	10	—	TDH01102 (5)	THE03849	TDH01103 (4)	TDH01104 (4)	THE03851
	115	11	—	TDH01105 (10)	THE03850	TDH01106 (5)	TDH01107 (4)	THE03852
	150	12	—	—	—	—	TDH01108 (4)	THE03853
	190	13	—	—	—	—	TDH01109 (5)	THE03854

(C*) = Number of Branch Circuits per heater (48 amps each branch max). For different circuit wiring configurations consult Tempco.

Ordering Information

Catalog Heaters

Order by catalog number for catalog heaters.

Standard lead time is 3 to 4 weeks.

Note that Replacement Element Part Numbers for each heater are also listed.

Custom Engineered/Manufactured Heaters

For sizes and ratings not listed, **TEMPCO** will design and manufacture a Duct Heater to meet your requirements. Specify if UL or CSA approval required.

Please Specify the following:

- | | | |
|---|--|---|
| <input type="checkbox"/> Duct size | <input type="checkbox"/> Element watt density | <input type="checkbox"/> Over-temperature thermocouple, if required |
| <input type="checkbox"/> Air flow velocity | <input type="checkbox"/> Element sheath material | <input type="checkbox"/> UL or CSA approval |
| <input type="checkbox"/> Inlet and outlet temperature | <input type="checkbox"/> Mounting flange material | <input type="checkbox"/> Any other modifications |
| <input type="checkbox"/> Wattage, voltage and phase | <input type="checkbox"/> Insulation thickness | |
| <input type="checkbox"/> Number of circuits | <input type="checkbox"/> Electrical enclosure type | |

WARNING: Cancer and Reproductive Harm - www.P65Warnings.ca.gov.

Power Control Panels for Process Heaters



Note: Power Control Panels featuring mechanical or solid state controls with all other necessary components can be provided by TEMPCO for any size duct heater. Refer to Section 13, pages 13-56 through 13-63 for complete details.



Enclosure Heaters

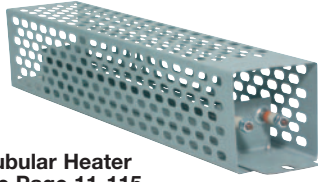

Tubular Heater
See Page 11-115



Silicone Rubber Heater
See Page 9-18

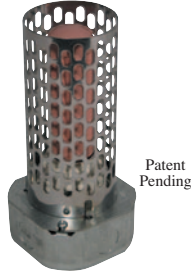

Ceramic Heater
See Page 7-41



Finned Strip Heater
See Page 8-15

Cabinet Enclosure Heaters

Tempco enclosure heaters are the answer to all your enclosure heater needs. Our heaters are designed to help electric, electronic, pneumatic, hydraulic and mechanical equipment perform at top capacity by protecting them against low temperatures, condensation and corrosion. Tempco offers many different styles of heaters that can be used in enclosure heating applications. Our most popular styles are displayed on the next few pages.

Typical Applications

- ✦ Traffic Signal Control Boxes
- ✦ Automatic Teller Machines
- ✦ Outdoor Electrical Power Enclosures
- ✦ Control Panels
- ✦ Control Valve Housings
- ✦ Switch Gear
- ✦ Clothing Lockers

Determining the Minimum Wattage for Your Application

1. Determine the lowest temperature to which the enclosure is expected to be exposed.
2. Determine the operating temperature to which you want the enclosure heated.
3. Subtract the ambient temperature from the enclosure temperature to get the temperature change required.
4. Calculate the surface area of the enclosure. For a rectangular enclosure use the formula:
 $2 [(Length \times Width) + (Length \times Height) + (Width \times Height)]$
5. Select the correct table below depending upon whether your box is insulated or non-insulated. Read from the table the wattage required depending upon your calculated temperature change and surface area.
6. Add an additional 50% of the determined wattage if the enclosure is to be located in windy conditions.

Selecting the Right Heater for Your Application

1. Determine the wattage of heater(s) that you need. See the instructions on this page to determine your wattage requirements.
2. Determine the type of heater that you need. Depending upon conditions, one heater type might be better than others. Items to take into consideration are space constraints inside the enclosure and wattages required.
3. Determine the number of heaters you need. You can combine multiple heaters to achieve your wattage requirements.
4. Determine how you will control the heaters. Will you use built-in thermostats to monitor the temperature? Or will you use a single temperature control to monitor and control the heaters? Tempco manufactures a wide range of temperature control devices and when multiple heaters are required, Tempco can supply you with the temperature controls that will meet your needs.

Insulated Enclosure Wattage Selection Table

Δ Temperature	TOTAL SURFACE AREA ft ² (m ²)														
	2 (0.19)	3 (0.28)	4 (0.37)	5 (0.47)	6 (0.56)	7.5 (0.70)	9 (0.84)	10 (0.93)	15 (1.40)	20 (1.86)	25 (2.33)	30 (2.79)	40 (3.72)	50 (4.65)	
20 (11)	10	10	15	20	20	25	30	35	50	65	80	100	130	160	
40 (22)	15	20	30	35	40	50	60	65	100	130	160	195	260	320	
60 (33)	20	30	45	50	60	75	90	100	145	195	240	290	385	480	
80 (44)	30	40	55	65	80	100	115	130	195	260	320	320	515	640	
100 (56)	35	50	65	80	100	125	145	160	240	320	400	400	640	800	
120 (67)	40	60	80	100	115	150	175	195	290	385	480	480	770	960	
140 (78)	45	70	90	115	135	175	205	225	340	450	560	560	900	1120	

Uninsulated Enclosure Wattage Selection Table

Δ Temperature	TOTAL SURFACE AREA ft ² (m ²)														
	2 (0.19)	3 (0.28)	4 (0.37)	5 (0.47)	6 (0.56)	7.5 (0.70)	9 (0.84)	10 (0.93)	15 (1.40)	20 (1.86)	25 (2.33)	30 (2.79)	40 (3.72)	50 (4.65)	
20 (11)	30	40	55	70	80	100	120	135	205	270	335	405	540	670	
40 (22)	55	80	110	135	160	200	245	270	405	540	670	805	1075	1340	
60 (33)	90	120	160	205	245	300	365	405	605	805	1005	1210	1610	2010	
80 (44)	110	160	215	270	325	400	485	540	805	1075	1340	1610	2145	2680	
100 (56)	135	200	270	335	405	500	605	670	1005	1340	1675	2010	2680	3350	
120 (67)	165	240	320	405	485	600	725	805	1210	1610	2010	2415	3220	4020	
140 (78)	190	280	375	470	565	700	845	940	1410	1880	2345	2815	3775	4690	

EHT Tubular Enclosure Heaters — Type 1 Box Style

Stock Heaters

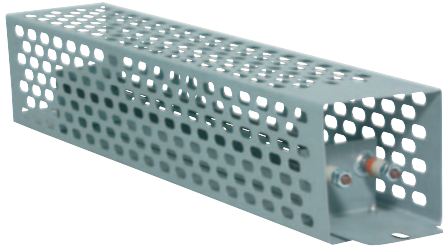

Wattage	3-1/2" Square by 8" Long Enclosure		3" Square by 15" Long Enclosure	
	120V	240V	120V	240V
100	EHT00006	—	EHT00017	—
250	EHT00008	EHT00009	EHT00019	EHT00020
350	EHT00010	EHT00011	EHT00021	EHT00022
375	EHT00012	EHT00013	EHT00023	EHT00024
400	EHT00054	EHT00055	EHT00056	EHT00057

Design Features

- * Incoloy tubular heating element
- * Up to 15 w/in²
- * 10-32 terminals standard

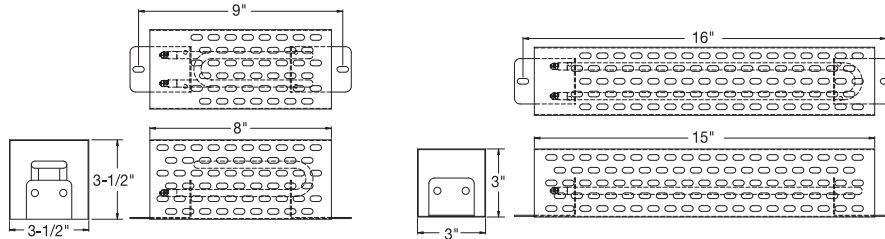

EHT Tubular Enclosure Heaters — Type 2 Open Style

Stock Heaters

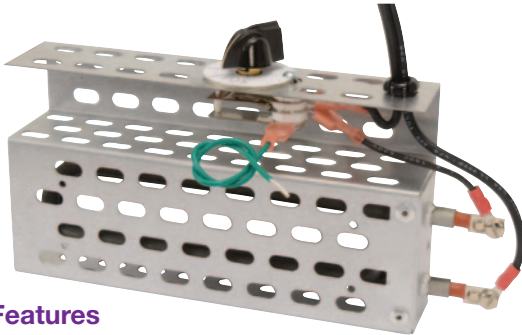

Wattage	Enclosure Heater			
	No Thermostat		With 30-150°F Thermostat	
	120V	240V	120V	240V
100	EHT00029	—	EHT00030	—
150	EHT00031	—	EHT00032	—
250	EHT00033	EHT00046	EHT00034	EHT00047
350	EHT00035	EHT00048	EHT00036	EHT00049
400	EHT00052	EHT00050	EHT00053	EHT00051

Thermostat models include 36" HPN line cord

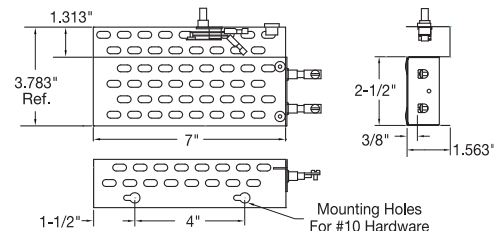

Design Features

- * Incoloy[®] tubular heating element
- * Available with 30-150°F thermostat prewired with 36" HPN line cord



Ordering Information

Catalog Heaters

Select a **Tubular Enclosure Heater** from the Standard Sizes and Ratings list above.

Custom Engineered/Manufactured Heaters

Standard lead time is 3 weeks. Please Specify the following:

- Size:** Provide the length and width of the perforated box desired.
- Wattage:** Tubular heater wattages up to 15 w/in²
- Termination:** Various terminations are available. Consult Tempco.
- Voltage:** All standard

⚠ WARNING: Cancer and Reproductive Harm - www.P65Warnings.ca.gov.

EHA — Remote Thermostats for Enclosure Heaters

Stock EHA Remote Thermostats



See Page 9-18 for details

Opens °F	Closes °F	Part Number
60±5	40±7	EHA00001
140±5	110±10	EHA00002
180±5	150±10	EHA00003

Electrically Heated Hose Assemblies



Design Features

- * Base Hose has a smooth bore Teflon® core with Stainless Steel overbraid.
- * Self-vulcanizing Silicone TGL bedding tape at 50% overlap.
- * Kapton® insulation wrapped stranded nichrome alloy heater element.
- * 2 layers of 1/8" Nomex® felt insulation.
- * Layer of 2" wide black tape for final wrap.
- * Heavy duty abrasive resistant outer covering, polyester braid; optional water resistant jacket is available upon request.
- * Heat shrink tube end caps.
- * Male NPT or 37° JIC female swivel fittings are standard; options include Tri-Clamp or Tubing/Pipe for compression fittings. Choice of Stainless Steel or plated carbon steel.
- * Temperature range to 450°F/232°C.
- * Overall length up to 600 inches.
- * Temperature sensors such as thermocouples or RTDs can be built-in to the assembly.
- * Snap action thermostats can be built in to the assembly to limit the maximum temperature.
- * 6 ft. power leads standard; length can vary upon request.
- * Hose assemblies available in 120 and 240 Vac.
- * Ground connection to the Stainless Steel overbraid.



Tempco's Control Consoles

Ideal for controlling process temperatures on heated hose assemblies. Complete information can be found on page 13-52.

Tempco's Electrically Heated Hose Assemblies are designed for optimum transfer of non-explosive liquids or gases. Tempco's HEH Transfer Hoses are Teflon® lined stainless steel braid heated flexible assemblies. Style R (regular pressure) or Style H (high pressure) transfer hoses are used in a wide range of applications such as water (freeze protection), steam, wax, plastics and many others. Heated transfer hoses improve fluid transfer for many applications.



Typical Applications

- ↔ Hot Melt Systems
- ↔ Petroleum Products
- ↔ Food Products
- ↔ Hot Oil Lines
- ↔ Chemical Transfer
- ↔ Gas Analyzer Systems
- ↔ Steam Transfer
- ↔ Water & Waste Disposal
- ↔ Bulk Transfer
- ↔ Paint Systems
- ↔ Tar & Asphalt
- ↔ Waxes – Candle Making
- ↔ Adhesives

Construction Characteristics

Tempco's Heated Transfer Hoses are built to the most stringent standards. Each hose is hand assembled to exact physical and electrical specifications. The heated hose assembly starts with the highest quality Teflon® smooth bore core with Stainless Steel overbraid style hose. Over this is wrapped a layer of self-vulcanizing silicone TGL bedding tape at 50% overlap as a base for the resistance wire. The stranded resistance wire is pre-wrapped with Kapton® insulation before winding around the growing assembly in the precise pattern required for uniform heating. Next is wound two layers of Nomex® felt insulation, to maintain consistent heat and a safe cool-to-the-touch design, followed by a layer of 2" wide black tape. The standard hose outer cover is an abrasion resistant polyester braid for normally dry environments. An optional outer cover can be provided for water resistant protection.

The hose assembly is then finished with heat shrink end caps, specified hydraulic fittings and electrical connectors. Hoses are also manufactured with optional built-in sensors including RTDs or thermocouples.

HEH Heated Hose Assembly Length Definition

1. For Heated Hose Assemblies with 37° JIC Female Swivel fittings, the specified Length is defined as fitting seat to seat.
2. For Heated Hose Assemblies with other permanently attached fittings, such as Tri-Clamps, Rigid NPT or Tubing, regardless of fitting type or gender, the specified Length is measured from the outside edge to the outside edge of the fittings.
3. Fitting adapters such as male JIC to male NPT, are not included in the Length specification.
4. Length Tolerances are stated as follows:

17.99" or less: ±0.5"	10 feet to 20 feet: ±1.5"
18" to 36": ±0.75"	20 feet to 50 feet: ±2.5"
3 feet to 10 feet: ±1.0"	



Specifications for Heated Hose Assemblies

Hose Size	Style R – Regular Pressure		Style H – High Pressure		Max. Rec. Watt Density (w/ft.)		Max. Working Pressure (PSI)		Minimum Bend Radius in. / mm	Male NPT Fitting Size SS	JIC Fitting Size, SS
	Core ID in. / mm	Hose Assembly OD in. / mm	Core ID in. / mm	Hose Assembly OD in. / mm	R Style		H Style				
					R Style	H Style	R Style	H Style			
#4	.187 / 4.75	1.40 / 35.6	.222 / 5.64	1.40 / 35.6	23	30	2250	4000	4 / 102	1/4-18	7/16-20
#6	.312 / 7.92	1.50 / 38.1	.308 / 7.82	1.50 / 38.1	25	40	1875	4000	8 / 203	3/8-18	9/16-18
#8	.406 / 10.31	1.59 / 40.4	.401 / 10.19	1.59 / 40.4	30	50	1500	4000	10 / 254	1/2-14	3/4-16
#10	.500 / 12.70	1.69 / 42.9	.495 / 12.57	1.69 / 42.9	35	55	1312	4000	13 / 330	1/2-14	7/8-14
#12	.625 / 15.87	1.79 / 45.5	.617 / 15.67	1.79 / 45.5	40	65	1125	4000	15 / 381	3/4-14	1 1/16-12
#16	.875 / 22.22	2.10 / 53.3	.867 / 22.02	2.30 / 58.4	50	85	750	4000	18 / 457	1-11 1/2	1 5/16-12
#20	1.12 / 28.57	2.60 / 66.0	1.118 / 28.40	2.70 / 68.6	65	95	500	4000	24 / 610	1 1/4-11 1/2	1 5/8-12



Notes: Operating pressures are for non-impulsive applications only.
#20 and High Pressure can only be done for special applications, consult Tempco.

Ordering Code:

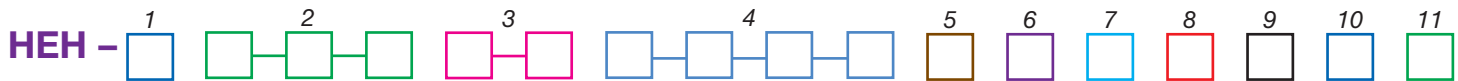

Hose Style BOX 1

R = Regular Pressure, Teflon®
H = High Pressure, Teflon®
X = Other

Length BOX 2

In 6" increments
From **006** to **600** inches

Trade Size BOX 3

04, 06, 08, 10, 12, 16, 20
XX = Other

Wattage BOX 4

Insert Required Wattage
Example: **0120** = 120 Watts



Note: Larger wattages are limited to 240V due to overall amperage requirements.

Voltage BOX 5

1 = 120 Vac
2 = 240 Vac
3 = 208 Vac
4 = 277 Vac
X = Other

Electrical Connectors BOX 6

A = Hubbell® #4720C, 15A, 120 Vac, locking plug (NEMA L5-15P)
B = Hubbell® #4570C, 15A, 240 Vac, locking plug (NEMA L6-15P)
C = Industry common, 9-pin Amp® connector
D = No connector, flying leads
E = Standard straight blade, 15A, 120 Vac, (NEMA 5-15P)
F = Standard straight blade, 15A, 240 Vac, (NEMA 6-15P)
X = Other

Temperature Sensor BOX 7

N = None
A = RTD, 100 ohms, platinum, 2-wire, leads only
B = Thermocouple, Type J, leads only
C = Thermocouple, Type K, leads only
D = RTD, 100 ohms, platinum, 3-wire, leads only
E = RTD, 100 ohms, platinum, 2-wire, Std. Plug
F = Thermocouple, Type J, Std. Plug
G = Thermocouple, Type K, Std. Plug
H = RTD, 100 ohms, platinum, 3-wire, Std. Plug
L = RTD, 100 ohms, platinum, 2-wire, Mini-Plug
M = Thermocouple, Type J, Mini-Plug
P = Thermocouple, Type K, Mini-Plug
Q = RTD, 100 ohms, platinum, 3-wire, Mini-Plug
X = Other



Note: It is strongly recommended that a sensor and separate temperature control or a thermostat be used to control the temperature of Tempco's Heated Hose Assemblies. It is very difficult to limit the overall temperature by using a lower wattage and have a reasonable rise time.

Hydraulic Fitting – Near Electrical Connection BOX 8

J = JIC 37° Female Swivel
N = JIC 37° Female Swivel and Male NPT adapter
Optional
T = Tri-Clamp
P = Tubing / Pipe (for compression fitting)
X = Other

Hydraulic Fitting – Opposite End BOX 9

J = JIC 37° Female Swivel
N = JIC 37° Female Swivel and Male NPT adapter
Optional
T = Tri-Clamp
P = Tubing / Pipe (for compression fitting)
X = Other

Hydraulic Fitting Material BOX 10

S = Stainless Steel
X = Other

External Covering BOX 11

P = Heavy duty polyester braid
Optional
N = Water resistant jacket (Available for limited sizes; consult Tempco)
X = Other

Ordering Information

Heated Hose Assemblies are offered with the features listed above. Create an ordering code by filling in the boxes with the appropriate number and/or letter designation for your requirements and a part number will be assigned.

Consult Tempco with your requirements.

Standard lead time is 2 to 3 weeks.

Accessory Item (Optional)

9-pin mating connectors, includes 12" of pre-attached leads to crimp sockets and cable clamp/strain relief.

Part Number	Mounting	Heated Hose Sensor Type
EHDR-1115	Cable	Type J thermocouple
EHDR-1207	Cable	Type K thermocouple
EHDR-1208	Cable	2 or 3 wire RTD temperature sensor
EHDR-1116	Panel	Type J thermocouple
EHDR-1209	Panel	Type K thermocouple
EHDR-1210	Panel	2 or 3 wire RTD temperature sensor

HET — Electrically Heated Tubing Assemblies

Tempco's electrically heat-traced tubing assemblies are designed for optimum transfer of non-explosive liquids or gases. Tempco's high purity PTFE Teflon® provides maximum flexibility for low pressure applications. Choose copper, aluminum or stainless steel tubing for high pressure applications.

We offer machine-wrapped heat tracing from 1/4" O.D. to 1-3/4" O.D., as well as hand-wrapped tracing of unusually small or large outer diameter tubing to meet a wide range of applications.

The key to Tempco's flexible, energy efficient, heat-traced tubing is the powerful low-profile heat tape spirally wrapped around your choice of tubing. The heat tape is manufactured with a top reflective layer to direct heat into the tube. This reflective layer, combined with the heat tape applied directly to the surface of the tube, results in a highly efficient thermal transfer. The simplicity of the heater design allows for the heated assembly to be extremely lightweight and flexible for use in portable and stationary applications. Each tube is then insulated with one or two layers of Nomex felt, depending on the temperature to be maintained.

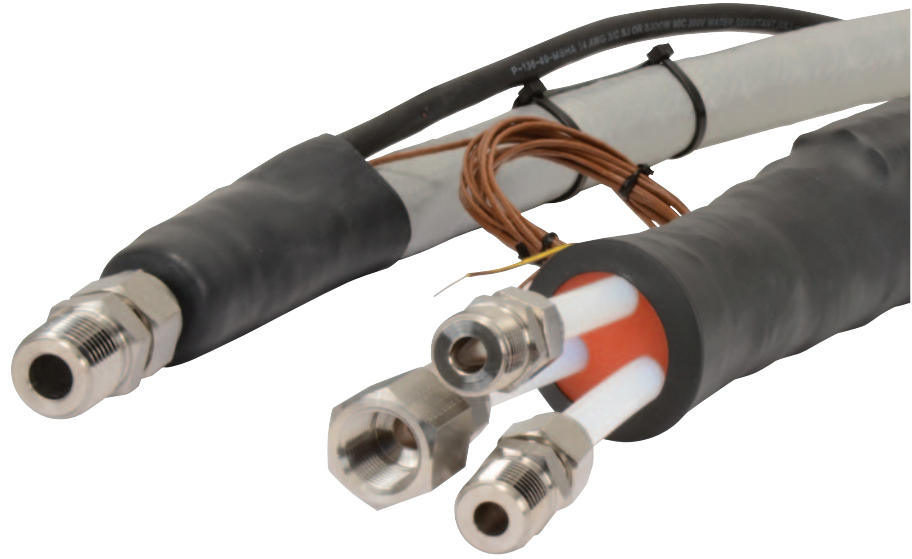

Typical Applications

- ✦ **Aerospace** * * * * *Satellites, Vacuum Chambers, Testing, Laboratory*
- ✦ **Automotive** * * * * *Fuel Cell Development, Cold Chamber Testing*
- ✦ **Composites** * * * * *Adhesives, Epoxy Transfer, 2-Part Spray*
- ✦ **Environmental** * * * * *EPA-Required Testing, Diesel Emissions*
- ✦ **Food Industry** * * * * *Viscosity Control, Production Technology*
- ✦ **Gas Samples** * * * * *Stack Samples, Analyzer Components*
- ✦ **Government** * * * * *Meteorological Analysis*
- ✦ **Industrial** * * * * *Machinery, Systems Engineering, Semiconductors*
- ✦ **Laboratory** * * * * *Thermal Testing, Instrumentation*
- ✦ **Medical** * * * * *Flow Control, Instrumentation, Scientific Research*
- ✦ **Pharmaceutical** * * * * *Production Machinery, R&D, Testing*
- ✦ **Transportation** * * * * *Aviation Freeze Protection, Heated Lines*
- ✦ **Universities** * * * * *Mechanical, Chemical, Electrical Engineering*

Design Features

- * *Base tubing can be Teflon®, Nylon®, Stainless Steel, Copper or Aluminum*
- * *Machine-wrapped low-profile flexible heat-tape with multiple heat conductors provides efficient thermal transfer, resulting in even heating from end to end.*
- * *Spirally wrapped Nomex® felt insulation bound in place with nylon braid.*
- * *Outer layer from simple heat shrink to moisture/contaminant resistant durable outer silicone sleeve.*
- * *Temperature range to 400°F / 200°C.*
- * *Heated Length to 100 ft. available in 1ft. increments. 1ft. unheated section at each end, shipped bare or with fittings.*
- * *Assembly can be designed with a replaceable inner tubing.*
- * *Temperature sensors include Type J, K or T thermocouples and RTDs.*
- * *Thermostats can be built in, eliminating the need for separate control.*
- * *Standard power leads include flying leads, 6 ft. cordset with standard plug or industrial Hubbell Twist-Lock® plug.*
- * *Up to 5 total Heated / Unheated tubes in the same bundle.*
- * *Built-in indicator lamps for Power On, Heat On or Over Temperature.*
- * *Voltage from 12VDC - 240 VAC.*



HET — Electrically Heated Tubing Assemblies

Ordering Information

Heated Tubing Assemblies are very application specific; Tempco will design and manufacture a Heated Tubing Assembly to meet your process requirements.

To receive a quote send a completed copy of the following Quote Request Form to Tempco.



⚠ WARNING: Cancer and Reproductive Harm - www.P65Warnings.ca.gov.

Electrically Heated Tubing Assembly Quote Request

Application Information

Desired Operating Temperature _____
Ambient Condition (indoor, outdoor?) _____
Worst Case Ambient Temperature _____
Expected Pressure _____
Material in the Tubing _____
Comments _____

Lead Information

Style: ___ Teflon® ___ Industrial Cordage
___ 120VAC cordset w/ standard 5-15 plug
___ 240VAC cordset w/ standard 6-15 plug
___ High Temp Fiberglass
Length _____ Optional Plug _____
Comments _____

Tubing Information

Tubing Material _____
(PTFE Teflon®, Copper, 304 SS, Aluminum)
Outside Diameter _____
Wall Thickness if Known _____
Heated Length _____
Overall Length _____
of tubes _____
 How many heated _____
 How many unheated _____
If replaceable inner tube required: ___ Yes ___ No
 Replaceable inner tube OD _____
Comments _____

Sensor & Control Information

Built-in Temperature Sensor: ___ Yes ___ No
Thermocouple Type (J, K, T) _____
RTD (PT100) ___ Yes ___ No
Lead Length _____
Lead Type _____
Built-In Thermostat ___ Yes ___ No
 Setpoint _____ (Choices limited to (°F): 40°, 77°, 86°, 98°, 104°, 120°, 140°, 176°, 212°, 248°, 302°, 356°)
Indicator Lamps: ___ Green, type _____
 ___ Red, type _____
Comments _____

Fitting Hardware Information

Bare ___ Compression + NPT: Male ___ Female ___
Comments _____

Electrical Information

Watts (total if Multi-Tube) _____
Volts _____ Phase: ___ Single ___ Three
If Multi-Tube: Watts per Tube _____
Comments _____

External Covering Information

___ Bare Heat Trace Only ___ Heat Shrink
___ Insulated Polyester Braid
___ Insulated Industrial Scuff Coat
Comments _____



Silicone Rubber Drum and Pail Heaters



Built tough

Resistant to chemicals

Ratings for Metal and Plastic Drums and Pails

Easy to clean

Stock to 2 week lead time

UL and CSA Approval
See page 9-2 for details

Design Features

- * Maximum operating temperature of 425°F (218°C).
- * Power cord is 6-foot long, SJO Type 16/3 complete with three-prong plug for 120 VAC models. Plugs are not included on 240 VAC models but are available (see page 15-15).
- * Surface grounded electrically with internal ground screen.
- * 1250 volts dielectric tested.
- * Vulcanized silicone rubber construction resistant to moisture, ozone, fungus, and radiation.
- * Adjustable thermostat, see page 9-16 for specifications.

Tempco flexible drum heaters can save time by heating stored viscous fluid to a pourable temperature.

The heater is built to be tough, long lasting, and resistant to chemicals. Because few materials stick to its silicone rubber with fiberglass reinforced construction, it is easy to clean. The heater comes with a 6-foot cord and plug (120V only). When not in use, it rolls for convenient storage.

The total wattage (number of heaters) and the material being heated inside of the drum must be considered when determining the actual temperature to which that specific material can be heated.

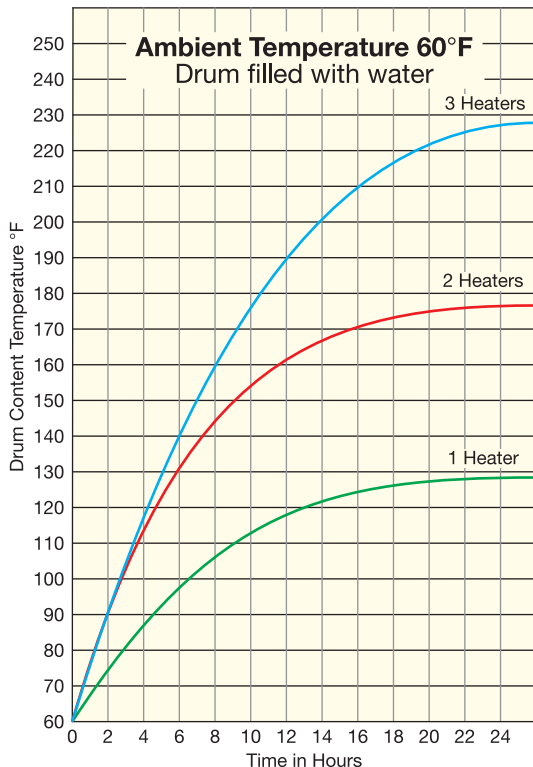

Standard (Non-Stock) and Stock Drum Heaters for Metal Drums

Stock Items Are Shown In **RED**

Drum Size	Drum Dia.	Heater Width	Heater Length	Watts	Part Number		Thermostat
					120V	240V	
5 Gal.	11.5	3"	31"	300	DHR00150	DHR01010	50-425°F
15 Gal.	13.5	3"	38"	500	DHR00110	DHR00130	50-425°F
30 Gal.	18	3"	52"	750	DHR00070	DHR00090	50-425°F
55 Gal.	22.5	3"	64"	1000	DHR00020	DHR00040	50-425°F
5 Gal.	11.5	3"	31"	300	DHR00140	DHR01041	No
15 Gal.	13.5	3"	38"	500	DHR00100	DHR00120	No
30 Gal.	18	3"	52"	750	DHR00060	DHR00080	No
55 Gal.	22.5	3"	64"	1000	DHR00010	DHR00030	No
5 Gal.	11.5	4"	31"	550	DHR01014	DHR01018	50-425°F
15 Gal.	13.5	4"	38"	700	DHR01013	DHR01017	50-425°F
30 Gal.	18	4"	52"	1000	DHR01012	DHR01016	50-425°F
55 Gal.	22.5	4"	64"	1500	DHR00050	DHR00055	50-425°F
5 Gal.	11.5	9.5"	31"	1000	DHR01023	DHR01047	70-190°F
15 Gal.	13.5	9.5"	38"	1000	DHR01024	DHR01046	70-190°F
55 Gal.	22.5	9.5"	64"	1500	DHR01025	DHR01045	70-190°F

Standard (Non-Stock) and Stock Drum Heaters for Plastic Pails

Stock Items Are Shown In **RED**

Drum Size	Drum Dia.	Heater Width	Heater Length	Watts	Part Number		Thermostat
					120V	240V	
5 Gal.	11.5	4"	31"	150	DHR01034	DHR01044	50-160°F
15 Gal.	13.5	4"	38"	200	DHR01035	DHR01036	50-160°F
30 Gal.	18	4"	52"	250	DHR01037	DHR01038	50-160°F
55 Gal.	22.5	4"	64"	300	DHR01033	DHR01039	50-160°F
5 Gal.	11.5	9.5"	31"	300	DHR01027	DHR01043	70-140°F
55 Gal.	22.5	9.5"	64"	750	DHR01026	DHR01042	70-140°F

Standard lead time is Stock to 2 weeks.

[View Product Inventory @ www.tempco.com](http://www.tempco.com)



Hazardous Area Rated Silicone Rubber Drum Heaters



Design Features

- * Dual setpoint NEMA 7 temperature controller connected to a high temperature limit indicator light
- * Extra wide 8" coverage area
- * Exceptional durability and flexibility
- * Grounded heating element meets NEC 427.23
- * Designed for metal drums



Hazardous Area Rated

Class I Division 2:
Groups A, B, C and D

Class II Division 2:
Groups F and G

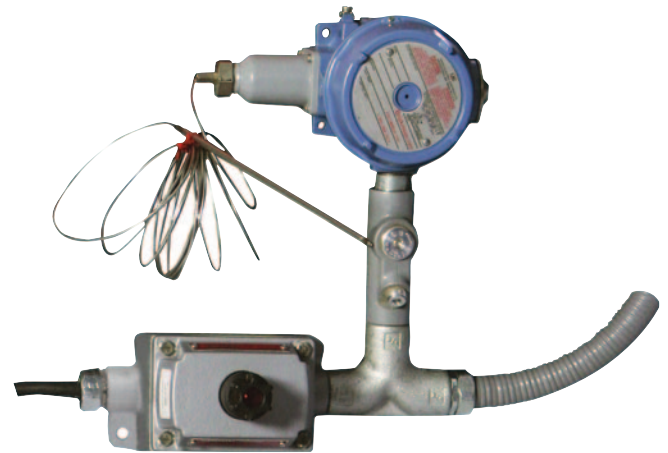

NEMA 7 Thermostat Control Assembly with High Limit Indicator Lamp

Specifications

Physical Description

Heating element is laminated between two layers of 23 mil and two layers of 25 mil fiberglass reinforced silicone rubber.

Power Density: 2.5W/sq.in.

Nominal Silicone Rubber Density: 26 oz/sq.yd.

Electrical Ratings

Wiring from Drum Heater to Controller: 6 ft. liquid-tight conduit

Line Cord from Controller Assembly: 6 ft. industrial power cord

Line Cord Termination: 120V – Hazardous area rated 5-15P plug
240V – No plug, flying leads

Thermostat

High Limit Thermostat:

- designed to keep blanket below NEC article 500-T rating:

T Rating	NEC Temperature	Actual High Limit
T3	392°F (200°C)	292°F (145°C)
T4A	248°F (120°C)	158°F (70°C)

- High limit red indicator lamp
- Attached adjustable dual setpoint thermostat NEMA 7 temperature controller. Moisture and chemical resistant.

Thermostat Range: 25°-325°F/-4°-163°C, dual scale limited by the "T Rating"

Ordering Information

Select the part number of the hazardous area silicone rubber drum heater that matches your requirements.

Standard lead time is 4 weeks.

Standard Hazardous Area Rated Drum Heaters

Drum Size Gallons	Drum Dia. in	Heater Width in	Heater Length in	Wattage	Part Number		T-Rating
					120VAC	240VAC	
30	18.6	8	58.5	1000	DHX00101	DHX00201	T-3
55	22.3	8	70.0	1300	DHX00102	DHX00202	T-3
30	18.6	8	58.5	1000	DHX00103	DHX00203	T-4A
55	22.3	8	70.0	1300	DHX00104	DHX00204	T-4A

⚠ WARNING: Cancer and Reproductive Harm - www.P65Warnings.ca.gov.

Metal Jacketed Drum Heaters

Speed Flow of Solid and Semi-Solid Viscous Materials with Tempco Electric Drum and Pail Heaters

Typical Drum Heater with Infinite/Variable Control



Optional Drip Guard
Prevents contamination of the heater from drum materials. Available for 55 gallon drums only.
Part Number: DHM00070

Design Features

- * Rapid heat-up of drum
- * Easy installation and removal
- * Durable metal design
- * Infinite switch or thermostat
- * 3-heat control
- * Indicator lamps: green for power, red for heater
- * 6 ft. power cord
- * Variety of diameters (all 5" wide) and ratings
- * Stock to 2 week lead time!
- * UL listed and CSA certified

Standard (Non-Stock) and Stock Sizes Stock Items Are Shown In RED

Drum Size	Temp Control	Watts	Volts	Part Number
55 GAL. 22.5" Diameter	Infinite/Variable Heat Control	1750	120	DHM00010
	60°-250°F Thermostat	1920		DHM00020 †
	200°-400°F Thermostat	1920		DHM00030†
30 GAL. 18.5" Diameter	Infinite/Variable Heat Control	3000	240	DHM00040††
	60°-250°F Thermostat			DHM00050 ††
	200°-400°F Thermostat			DHM00060 ††
16 GAL. 14.5" Diameter	Infinite/Variable Heat Control	1750	120	DHM00080
	60°-250°F Thermostat	1920		DHM00090†
	200°-400°F Thermostat	1920		DHM00100†
5 GAL. 11.25" Diameter	Infinite/Variable Heat Control	1500	120	DHM00110
	60°-250°F Thermostat			DHM00120
	200°-400°F Thermostat			DHM00130
5 GAL. 11.25" Diameter	Infinite/Variable Heat Control	1500	120	DHM00140
	60°-250°F Thermostat			DHM00150
	200°-400°F Thermostat			DHM00160

Thermostat Control models sense temperature in an area remote from the heating element and will automatically cycle heater to maintain set temperature. Three-heat switch allows three wattage ratings per thermostat setting and voltage rating.

Infinite/Variable Control models cycle the current ON and OFF. The ratio of ON time will increase as the control is advanced. Three-heat switch allows the operator to control the heater output within a given 3 settings of high, medium, or low.

Standard lead time is Stock to 2 weeks.

† The 1920 Watt/120V model is equipped with a special high amperage plug. If required the matching receptacle is: Part Number EHD-103-108 (Hubbell® #5361, 20A, 125V)

†† The 3000 Watt/240V is equipped with a standard 15A/240V straight blade type plug.

Typical Applications

Industries	Applications	Industries	Applications
Mining & Oil Companies	Heat diesel fuel, grease, etc. in cold weather	Farm Supply Distributors	Heat tallow to 140°F to mix with feed ration
Candle Makers	Heat wax to make candles	Beekeepers	Reliquefy honey after crystallizing
Food Processors	Heat food additives	Roofers	Heat roofing material during cold weather
Aircraft Mechanics	Heat aircraft grease during cold weather	Chemical Manufacturers	Heat chemical components
Auto Mechanics/ Undercoaters	Accelerate flow of undercoating material	Chemical Users	During the manufacturing process
		Furniture Manufacturers	Heat adhesives

Stock Heated Drum Dolly for Metal Drums



Holds up to 900 lbs.

Chain Link Reinforced Power Cord

Infinite Variable Heat Control

Heat your 55 gallon drum while keeping it portable. Just place the drum on the dolly's 3/4" thick x 15-1/4" square heated platen.

The overall diameter is 28-1/2" with an inside diameter of 24". The dolly comes equipped with 3" diameter phenolic casters and a 6 foot long cord and plug.

Part Number: **DHM01001** 1750 Watts, 120VAC

Part Number: **DHM01002** 1920 Watts, 240VAC

Drum Immersion Heaters

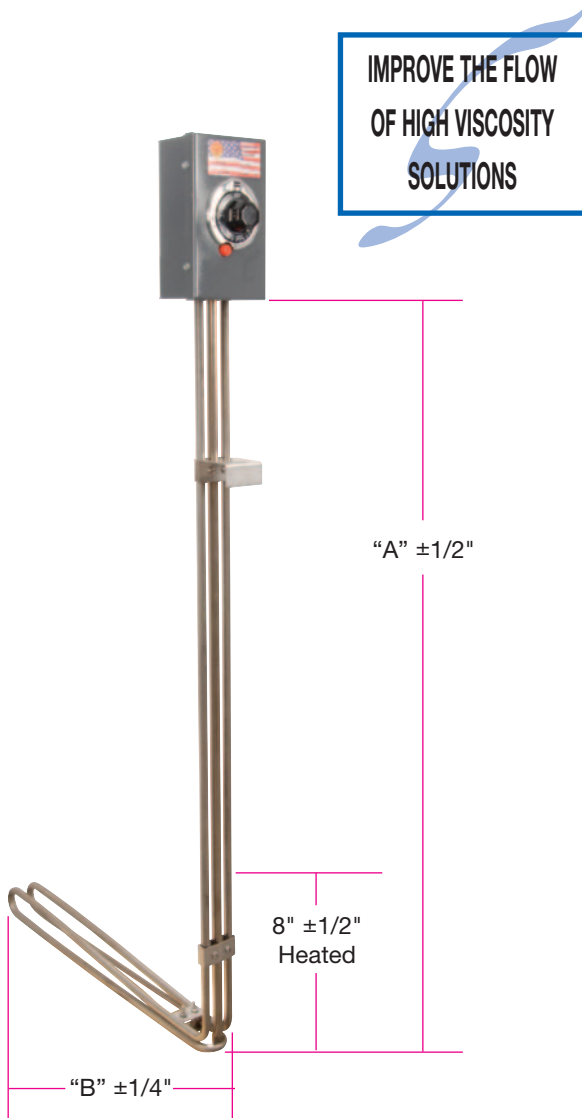

Design Features

- * Fits through the standard 2" bung opening in 55 gallon drums
- * Ideal for improving the flow of lard, tar, oils and other high viscosity solutions
- * Double Pole 60-250°F thermostat with over-temperature cutout and pilot lamp to indicate heater on/off status
- * Only 8" of vertical riser is heated, allowing liquid level to fluctuate without damaging the heater
- * Adjustable stainless steel mounting bracket

Optional Features

- * Passivation, electropolished, or bright annealed surface treatments available for Stainless Steel or Incoloy sheath designs.
- * NEMA 4 (moisture resistant) and/or NEMA 7 (explosion resistant) terminal enclosures
- * External Power wiring options include flexible cord/plug, armored cable, wire braided or plain lead wire.
- * Process or Hi-Limit thermocouple in thermowell in place of the thermostat

Installation, Operation & Maintenance Instructions

1. Ensure the vertical heated portion, which extends 8" up riser from bottom of element, is always fully immersed.
2. Use in metal drums, containers or heat resistant tanks only.
3. All wiring should be in accordance with NEC/NFPA and local codes.
4. Use techniques safe for the heater and surrounding environment.
5. Use mounting brackets to position heater away from tank wall and above sludge buildup at bottom of tank.
6. Periodically remove the heater to clean residues and inspect for damage.

Standard (Non-Stock) and Stock Sizes

Stock Items Are Shown In **RED**

Sheath	Watt Density w/in ²	Watt Density w/cm ²	Watts	Volts	"A" Dim. in	"B" Dim. in	Part Number
Copper	8	1.2	1000	120	36	19	TAT30003
	32	5.0	4000	240	36	19	TAT30004
Stainless Steel	8	1.2	1000	120	36	19	TAT30002
	32	5.0	4000	240	36	19	TAT30001
Steel	8	1.2	1000	120	36	19	TAT30005
	32	5.0	4000	240	36	19	TAT30006



Hazard of electric shock. Heater installation must be grounded. Heater must be disconnected from power input before servicing or removal.



Note: This style heater can be manufactured with "A" and "B" dimensions suitable for other applications. Consult Tempco with your requirements.

Ordering Information

Catalog Heaters

Order by Part Number for catalog heaters listed.

Custom Engineered/Manufactured Heaters

An electric heater can be very application specific; for ratings not listed, **TEMPCO** will design and manufacture an Immersion Heater to meet your requirements. **Standard lead time is 3 weeks.**

Please Specify the following:

- | | |
|--|---|
| <input type="checkbox"/> Application | <input type="checkbox"/> "A" and "B" Dimensions |
| <input type="checkbox"/> Wattage, Voltage | <input type="checkbox"/> Unheated Section |
| <input type="checkbox"/> Element Sheath Material | <input type="checkbox"/> Optional Features |
| <input type="checkbox"/> Element Watt Density | <input type="checkbox"/> Quantity |

WARNING: Cancer and Reproductive Harm - www.P65Warnings.ca.gov.

Full Coverage Drum Blanket Heaters

Tempco's Full Coverage Drum Blanket Heaters are designed to wrap around a drum and heat the contents while insulating to keep the heat exactly where it needs to be.

Full Coverage drum heaters combine the convenience of quick heat-up time and the precision of a digital controller to provide you with the practical, efficient means of freeze protection, viscosity control, and maintenance of materials at elevated temperatures.



Design Features

* **Digital On-Off Controller Range:**

For Metal Drums: 50° to 450°F (10° to 232°C)

For Poly Drums: 50° to 160°F (10° to 71°C)

* **Facing and Liner Material: Silicone impregnated cloth**

* **Insulation: 1" thick Fiberglass**

* **Heated Area: Lower 67% (2/3)**

* **Unheated Area: Upper 33% (1/3)**

* **Maximum Exposure - Heating Surface: 500°F (260°C)**

* **Closure: Hook and Loop (similar to Velcro®)**

* **Grounded Heating Element**

* **Dielectric Strength: Over 2000VAC**

* **Power Cord: 120V: 6 ft. with standard NEMA 5-15 plug
240V: 6 ft. with standard NEMA 6-15 plug***

**(240VAC Celcius models have crimped wire ferrule terminated leads)*

* **Designed for Indoor Use only**

Typical Applications

- ↪ Viscosity Control
- ↪ Freeze Protection
- ↪ Melting of Solids
- ↪ Heat up drum contents to a desired temperature
- ↪ Thermal Mixing



55 Gallon Single Zone Full Coverage



55 Gallon Dual Zone Full Coverage

Dual Zone Drum Blanket Heaters include two independently controlled and wired heater sections for better uniformity, control and higher wattage.

Full Coverage Drum Blanket Heaters

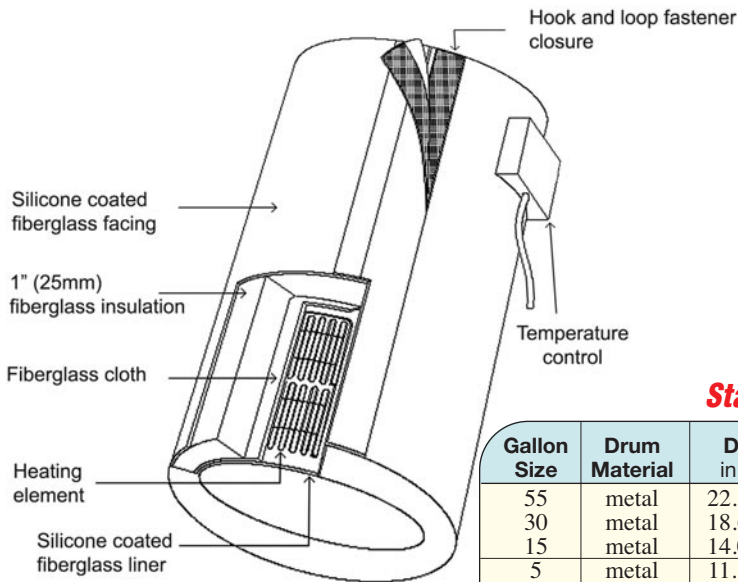

Ordering Information
Drum Blanket Heaters are ordered by Part Number.
 Available set up for °C. Consult Tempco.
 Standard lead time is 3 weeks.

Standard Full Coverage Blanket Heaters

Gallon Size	Drum Material	Diameter		Height		Number of Zones	Total Wattage	Part Number	
		in	mm	in	mm			120 VAC	240 VAC
55	metal	22.3	565	36.4	924	1	1600	DHB00101	DHB00201
30	metal	18.6	473	29.5	749	1	1160	DHB00102	DHB00202
15	metal	14.0	355	26.7	678	1	870	DHB00103	DHB00203
5	metal	11.1	282	13.5	343	1	550	DHB00104	DHB00204
55	poly	22.3	565	36.4	924	1	770	DHB10101	DHB10201
55	metal	22.3	565	36.4	924	2	3200	—	DHB20201

Full Coverage Drum Insulation Blanket & Accessories



55 Gallon Drum Full Coverage Insulation Blanket

Design Features

- * Compatible with any 55 gallon drum heater
- * Reduces heat loss
- * Improves uniformity
- * Similar construction as the Full Coverage Drum Blanket Heater
- * Designed for indoor use



Insulation Cover with openings for bung hole and vent

Part Number	Description
DHB00055	55 gallon, 22.3"/565 mm diameter Unheated Drum Insulation Assembly
DHB00001	Insulation Cover for 55 gallon drum
DHB00002	6" (152 mm) wide extension strip for 55 gal. drums to fit up to 24.2" (615mm) diameter. Required for 55 gal. drums with removable lids.

Ordering Information
Drum Blankets are ordered by Part Number.
 Standard lead time is 2 to 3 weeks.

⚠ WARNING: Cancer and Reproductive Harm - www.P65Warnings.ca.gov.

WCT - Tote Tank/IBC Heater Systems



The contents in Tote Tanks and Intermediate Bulk Containers (IBCs), such as honey, molasses, or lube oil, can be slow moving and uncooperative when the material is needed most, especially during winter. Heat allows the contents to flow at a manageable rate.

Design Features

- * *Two Styles: WCT1 Wraparound Full Coverage Blanket Heater
WCT2 Heating Pad that is placed underneath the Tank/Bladder*
- * *Does not contaminate or scorch your product*
- * *Durable and Long Lasting*
- * *Variety of Standard Sizes and Made-to-Order*

Typical Applications

- ↪ *Viscosity Control*
- ↪ *Freeze Protection*
- ↪ *Temperature maintenance*
- ↪ *Melting of Solids*
- ↪ *Heat-Up Tote Tank / IBC contents to a required temperature*
- ↪ *Thermal Mixing*



WCT1 Wraparound Full Coverage Blanket

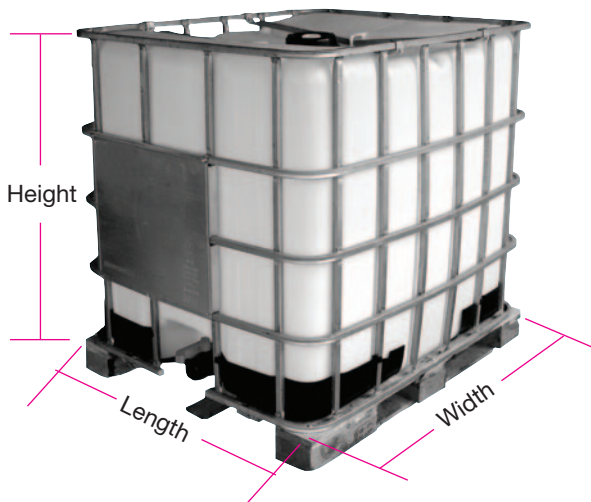

How to measure your Tote Tank / IBC

1. Measure the height of the Tote Tank/IBC, not including the pallet or support.
2. Measure the length and width of the tank. This determines the tank perimeter.

$$\frac{\text{length}}{\text{(length)}} \times 2 + \frac{\text{width}}{\text{(width)}} \times 2 = \frac{\text{perimeter}}{\text{(perimeter)}}$$

Note: If the tank perimeter measurement is below 160" (4064 mm) or above 192" (4877 mm), contact Tempco for a Made-To-Order recommendation.

WCT1 Wraparound Full Coverage Blanket Heater

- Designed for caged, plastic, or metal tote tanks / IBCs
- Wraparound blanket design allows you to heat a tote tank / IBC from the outside to avoid contamination inside
- Does not contaminate or scorch your product
- Two separate heat zones allow you to adjust heater output when content levels decrease



Control each zone with dual thermostats. Protect contents with manual reset high limit safety thermostats.



Fits several Tote Tank sizes with adjustable nylon straps and buckles



Design Features

- * Full coverage plug-and-play system
- * Fits any tote tank from 40" x 40" (1016 mm x 1016 mm) to 48" x 48" (1219 mm x 1219 mm)
- * Three standard height sizes: 36" (914 mm), 42" (1067 mm) and 48" (1220 mm)
- * Two separate heat zones (top and bottom)
- * Adjustable thermostat: 50-160°F (10-71°C)
- * Built-in manual reset high-limit safety thermostat set at 195°F (91°C) for each heat zone
- * Attachment method: adjustable nylon straps with buckles (Two across the top and three around the tank)
- * Silicone impregnated cloth facing and liner
- * 1/4" (6 mm) fiberglass insulation
- * "Mouse hole" designed for spigot
- * Grounded for your safety
- * 120 or 240VAC
- * Total wattage: 120VAC = 1440 watts
240VAC = 2880 watts
- * Power cord 6 ft. (1.8M) long with standard 3-prong power plug: 120VAC (NEMA 5-15), 240VAC (NEMA 6-15)
- * Optional insulated top cover (reduces heat loss and accelerates heat-up)

Standard WCT1 Wraparound Full Coverage Blanket

Height	Tank Perimeter		Tank Perimeter		Weight		Wattage	Voltage	Part Number
	Minimum	Maximum	Minimum	Maximum	lb	kg			
36	160	192	4064	4877	34	15	1440	120	WCT10101
36	160	192	4064	4877	34	15	2880	240	WCT10201
42	160	192	4064	4877	40	18	1440	120	WCT10102
42	160	192	4064	4877	40	18	2880	240	WCT10202
48	160	192	4064	4877	46	21	1440	120	WCT10103
48	160	192	4064	4877	46	21	2880	240	WCT10203

Ordering Information

Select the part number of the full coverage blanket heater that matches your requirements.

Standard lead time is 3 weeks.

Available set up for °C. Consult Tempco.

Insulated Tote Tank / IBC Top Cover Part Number WCT90001

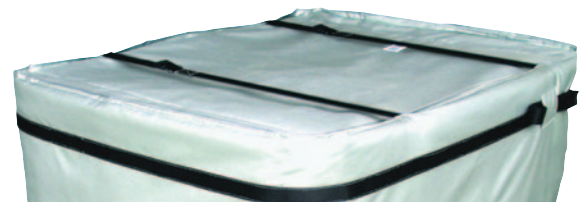

⚠ WARNING: Cancer and Reproductive Harm - www.P65Warnings.ca.gov.

Series WCT2 Silicone Rubber Heater Pad and Control — Used under Tote Tanks and IBCs



- Ideal for a wide range of outdoor and indoor caged tote tank / IBC heating applications.
- Quick heat-up time due to direct surface contact underneath plastic bladder.
- Non-invasive heat: Does not contaminate or scorch your product.
- Your choice of either Tempco's PCT-2000 Non-Indicating Temperature Control or PCT-3000 Digital TEC-220 based PID Temperature Control.

PCT-2000 Series



PCT-3000 Series



Design Features

- * Includes either Tempco's PCT-2000 Non-Indicating Dual °F/°C Scale Temperature Control (indoor use) or PCT-3000 Digital TEC-220 based PID Temperature Control (indoor/outdoor use). Easy plug-and-play connections
- * Wire-wound heating element is uniformly placed to maximize heat distribution
- * Heating element is laminated between two extra-thick layers of 20 mil fiberglass reinforced silicone rubber
- * Type K thermocouple built in to IBC heating pad
- * Moisture and chemical resistant silicone rubber heating pad
- * Weight-absorbent 1/2" (13 mm) thick foam pad
- * 180°F (82°C) maximum exposure temperature
- * Heater pad leads 6 ft. (1.8m) long with power and thermocouple plug
- * Temperature control input power cord is 5-foot (1.5m) long with standard three-prong plug 120VAC (NEMA 5-15), 240VAC (NEMA 6-15)

Installs Underneath the Bladder for Rapid Heat-Up



Standard WCT2 Tote Tank / IBC Heater Pads and Controls

Heater Size	Wattage	Volts	Setpoint Range	System Part Number	Replacement Controller Part Number	Replacement Heater Assembly Part Number
32" x 36"	1600	120	0 - 175°F	WCT20101	PCT30005	SHS02858
32" x 36"	3200	240	0 - 175°F	WCT20201	PCT30006	SHS02859
32" x 36"	1600	120	0 - 175°F	WCT20102	PCT20006	SHS02858
32" x 36"	3200	240	0 - 175°F	WCT20202	PCT20007	SHS02859



Table Of Contents

Pictorial Index	A-30	Infrared Non-contact Temperature Measurement for Process Applications	12-34
Chart Recorders:		Temperature Transmitters— Miniature and Rail Mount	12-44
PPS Videographic Data Recorders	12-2	Multiple Input Thermocouple Monitors	12-52
RCR-600 100mm Chart Recorder	12-10	Bimetal Dial Thermometers	12-54
Rotating Multi-Pin Electrical Connectors	12-12	Wire Mounted Current Indicators and Relays	12-58
Melt Pressure Transducers	12-18	Electronic Test Instruments	12-58
Melt Pressure Gauges	12-24	Digital Handheld Thermocouple Thermometers	12-60
Melt Pressure Electronic Indicators & Accessories	12-26		
Extruder Rupture Discs	12-29		
Infrared Non-contact Thermometers—Portable	12-30		

Temperature Controllers can be found in Section 13

Instrumentation

12

section

PPS Series Videographic Data Recorders

Now with Touch Screen Technology!



PPS-1000

PPS-2000

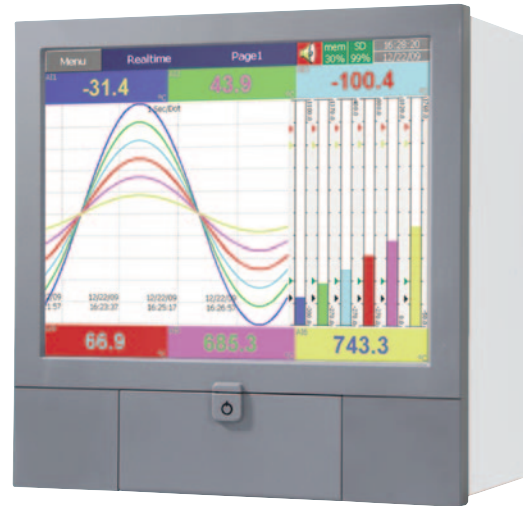

PPS-3000

Product Overview

- * The PPS Series is a major advance in the market for Paperless Videographic Data Recorders incorporating Touch Screen Technology for set-up and programming.
- * *The PPS Series encompasses three models:*
 - The PPS-1000 for basic 3 or 6 channel recording on a 4.3" screen
 - The PPS-2000 for up to 24 channels on a 5.6" screen
 - The PPS-3000 expandable to 48 channels on a 12.1" screen
- * The PPS Series displays data in real time on the touch screen.
- * The PPS saves data to internal memory that can be exported to SD memory cards or USB ports as well as over a LAN using the optional Data Acquisition Software.
- * Data logging supports notes being written directly on the Touch Screen that may be saved with the data files. The data files may be started and stopped as a batch operation with additional batch lot information.
- * *The Basic PC software package included at No Charge provides:*
 - Historical Viewer/Configuration capability to view, print, export and archive PPS Series data files imported via SD card or USB drive
 - Create and edit PPS configurations to be downloaded back to the recorder
- * Data Acquisition Studio software combined with the Basic package provides real time access from one or more PPS units via LAN, serial or Modbus with datalogging functions at the PC.
- * Optional firmware packages include the Panel Studio development software to design custom displays including digital and analog tags and values with animation.



Design Features

- * *Touch Screen Technology*
- * *TFT high resolution color LCD*
- * *100 millisecond sample rate and data logging*
- * *High accuracy 24 bit A-D analog inputs*
- * *16 bit A-D analog outputs*
- * *Digital count inputs, maximum frequency 100 Hz*
- * *Plug & Play I/O card/modules:*
 - Analog Input - 3 or 6 per card
 - Analog Output - 6 per card
 - Digital Input - 6 per card
 - Digital/Relay Output - 6 per card
 - Combo Card - 3 Digital Inputs + 3 Relay Outputs
- * *SD Slot for internal memory expansion*
- * *(2) USB host ports for downloading data or printer connection*
- * *6.73"/171mm short panel depth*
- * *Ethernet standard with optional RS-232 or RS422/485*
- * *NEMA 4X / IP65 water resistant housing*



PPS Series Videographic Data Recorders



PPS-2000 Front View

Front Panel Features

- * **High resolution TFT LCD Color Touch Screen**
 - PPS-1000: 4.3", 480 × 272 resolution
 - PPS-2000: 5.6", 640 × 480 resolution
 - PPS-3000: 12.1", 1024 × 768 resolution
- * **SD slot for external memory: 16G or 32G**
- * **1st USB slot, for memory, auxillary or printer**
- * **Reset - To Reset and Restore factory settings**
- * **Start/Stop - To Start or Stop channel recording, or to turn the screen on or off**
- * **Front Door - Key locked for security**

Back Panel Features

- * **Multiple slots for Input/Output modules**
 - PPS-1000 4 slots, 6 analog channels maximum
 - PPS-2000 4 slots, 24 analog channels maximum
 - PPS-3000 16 slots, 48 analog channels maximum
- * **Optional RS-232/422/485 Serial communications**
- * **Ethernet port, standard for Internet/Intranet coms**
- * **2nd USB slot for memory, auxillary or printer**
- * **Power Switch**
 - Optional for panel style mounting
 - Standard for portable style mounting
- * **Power Terminals, for input power connections**



PPS-2000 Rear View

Input / Output Modules

* **Input/Output modules can be added or removed to the rear of the unit easily. The modules are locked in with screws.**

* **Input/Output module types are:**

- 6 - channel Analog Inputs
- 3 - channel Analog Inputs
- 6 - Relay Outputs, 5A 240V, NO and NC
- 6 - Digital Inputs
- 3 - Relay Outputs and 3 - Digital Inputs
- 6 - Analog Outputs



I/O Modules for Simple Expansion

PPS Series Videographic Data Recorders

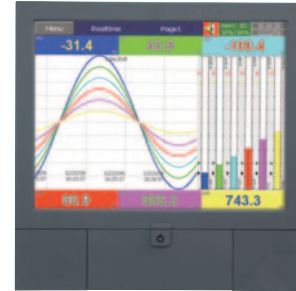
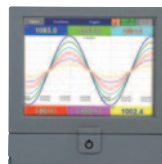

PPS-1000

PPS-2000

PPS-3000

Analog Input Channels	3 or 6	3, 6, 12, 18, or 24	6, 12, 18, 24, 30, 36, 42 or 48
Universal Analog Inputs	Thermocouples: J, K, T, E, B, R, S, N, L, U, P, W5, W3, LR, A1, A2, A3, M; Linear: mA, mV, V RTD: Pt50, Pt100, Pt200, Pt500, Pt1000 ($\alpha=0.00385$) Pt50, Pt100 ($\alpha=0.00391$) JPt50, JPt100, JPt200, JPt500, JPt1000 ($\alpha=0.003916$) Cu10, ($\alpha=0.00427$), Cu50, Cu100 ($\alpha=0.00426, 0.00428$) Ni100, Ni200, Ni500, Ni1000 ($\alpha=0.00617$)		
Sampling Rate	100mS, 24 bit Analog to Digital Converter		
Math, External Channels, FDA 21 CFR part 11	Available in optional Plus versions of the firmware.		
Display, Touch Screen	4.3" TFT Color LCD	5.6" TFT Color LCD	12.1" TFT Color LCD
Resolution	480 x 272	640 x 480	1024 x 768
Email, Screen Saver	Yes	Yes	Yes
CPU	ARM Cortex-A8, 1 GHz	ARM Cortex-A8, 1 GHz	ARM Cortex-A8, 1 GHz
Internal Flash Memory	256 MB	256 MB	256 MB
Internal RAM	256 MB	256 MB	256 MB
Ethernet	Modbus TCP/IP	Modbus TCP/IP	Modbus TCP/IP
RS-232/422/485	Optional RS-232 or RS-422/485 Modbus RTU in the rear		
SD card slot, USB	Standard SD and one USB in the front, one USB in the rear		
Pulse Input	Optional Digital Input Card for either logic or high frequency counter		
START/STOP switch	Start/Stop channel recording, and manually turn off the display		
Calibration	On site calibration or channel correction using Offset and Gain		
Multilingual	Programmable in Brazil Portuguese, Chinese (simplified and traditional), Czech, Danish, Dutch, English, French, German, Greek, Italian, Japanese, Korean, Polish, Portugese, Russian, Spanish, Thai and Turkish		
PC Software	Configuration and Historical Viewer - Standard; Real Time monitoring and Data Acquisition Studio - Optional		
Power Supply	90-250 VAC or 11 - 36 VDC		
Outer Dimensions (WxHxL)	5.67" x 5.67" x 7.44" (144 x 144 x 189mm)	5.67" x 5.67" x 7.44" (144 x 144 x 189mm)	11.34" x 11.34" x 7.44" (288 x 288 x 189mm)
Panel Mounting Depth	6.73" (171mm)	6.73" (171mm)	6.73" (171mm)
Panel Cutout	5.39" x 5.39" (137 x 137mm)	5.39" x 5.39" (137 x 137mm)	11.06" x 11.06" (281 x 281mm)
Protection Rating	NEMA 4X / IP65 front; IP20 rear		
Operating Temperature	32° to 122°F (0° to 50°C)		
Storage Temperature	-22° to 158°F (-30° to 70°C)		
Safety Standards	cURus, RoHS		

Firmware Features

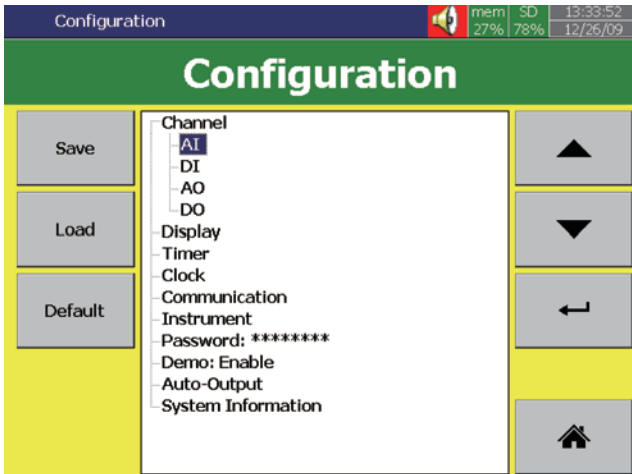

Configuration in Indented Layout for easy operation

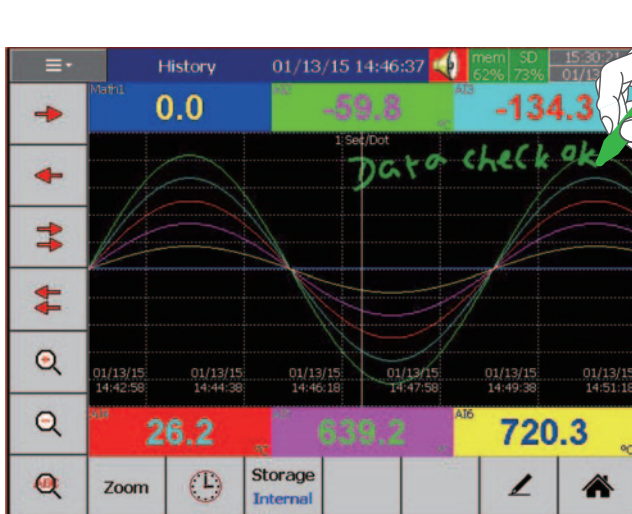

Free hand note taking, directly on the screen

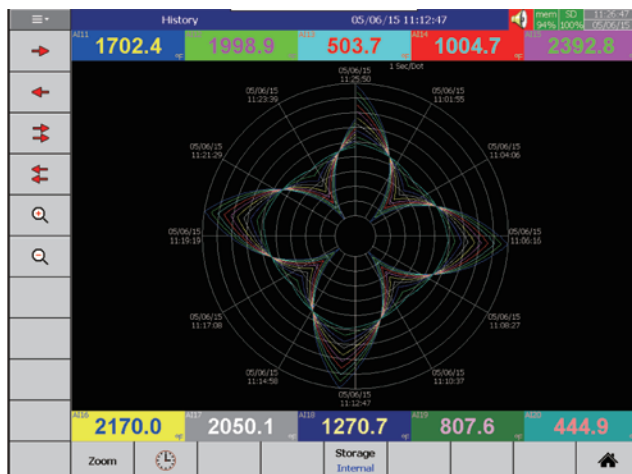

Display simulates Circular Chart Recorder (PPS-3000 only)

Standard Firmware Package

- **AI:** Analog Input is offered in various logging speeds of 100mS, 1, 2, 5, 10, 20, 30 Sec., 1, 2 minutes
- **DI:** Digital Input can be configured for Normal Logic or High Frequency Pulse
- **AO:** Analog Outputs can be configured in mA or Volts and it's function defined.
- **DO:** Digital/Relay Outputs can be enabled for process functions
- **Display:** Various display speeds can be set in 100mS, 1, 2, 5, 10, 20, 30, Sec., 1, 2, 10, 30 min./page, 1, 2, 4, 8, 12 hrs./page, 1 day/page
- **Timer:** Timer configured in Countdown, Repeat Countdown, Daily, Weekly, of Monthly base and various jobs can be defined
- **Clock:** Date Style of MM/dd/yy or dd/MM/yy, Time Synchronize via Internet, and Daylight Savings Time can be defined
- **Communications:** Web Server and E-mail functions
- **Instrument:** Brightness adjustment & Screen Saver
- **Password:** If Normal Security is chosen, then one password is offered. If the high security of CFR-21 is chosen, then 9 levels of passwords can be defined
- **Demo:** Built-in Demonstration of the instrument's features can be activated

Optional Firmware Plus 1 Package

- Math, Counters and Totalizer functions within derived channels
- Derived Channels by Model Number:
PPS-1000: 15 derived channels
PPS-2000: 40 derived channels
PPS-3000: 60 derived channels
- High frequency pulse inputs can be configured from digital inputs
- With the CFR 21 security feature enabled, the PPS Series meets the requirements for electronic data for FDA 21 CFR part 11
- External Channel Input: The PPS Series is configurable as a Master or Slave device with the number of external channels varying by Model. The External Channels require Modbus RTU protocol over either the TCP/IP Ethernet port or the optional serial RS232/485
- Data log Batch start/stop allows batch data file name, file duration, lot number and up to 3 comments to be stored as part of the file



Firmware Features

Continued from previous page...

Optional Firmware Plus 2 Package

- Panel Studio development software allows the user to custom design display views that provide a graphical representation of the application including animation as well as digital and analog tags and values.
- The user can use Panel Studio to edit specific displays on the PC first and then download it onto the recorders.
- The custom edited displays will be added to the standard pages.

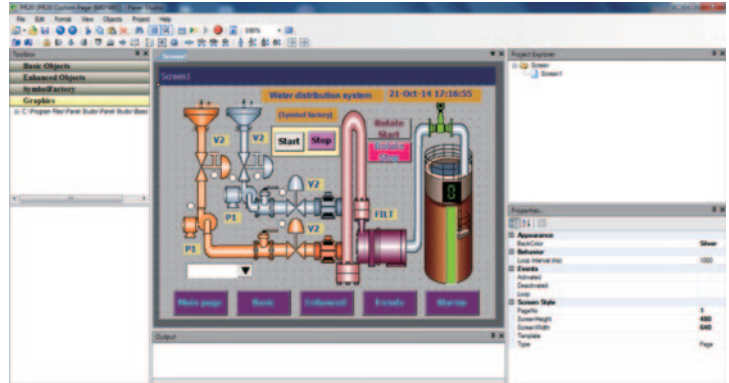

Create and edit the display on the PC

Optional Firmware Plus 3 Package

- This package is a combination of the Plus 1 and Plus 2 firmware features.
- It features Extended Math Functions, FDA 21 CFR part 11 compliance and Panel Studio development software.

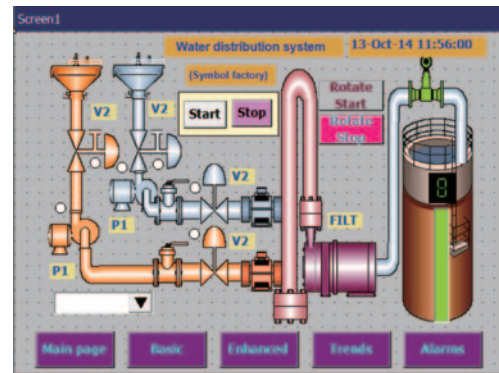

Download it into the Recorder

Software Features

Standard Basic Software

- Configuration:** Create and edit recorder configurations including projects, analog channels, external and math channels, Events, Inputs, and Outputs, Power, etc. and download the configuration back to the recorder via LAN, SD or USB cards.
- Historical Viewer:** Provides the capability to view, print, export (csv.) and archive PPS Series data files imported via LAN, SD or USB cards.

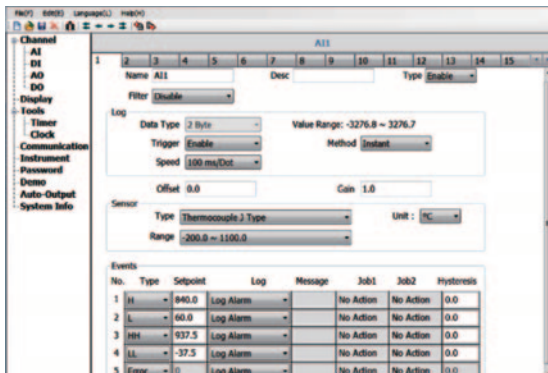

Configuring an Analog Input Channel

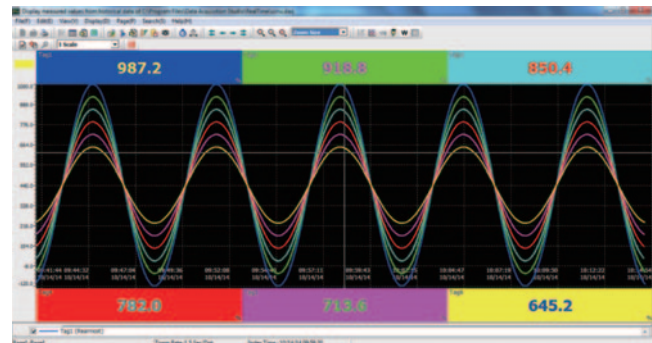

Historical view of multiple channels

Software Features (continued)

Optional Extensive Software Package

- In addition to the standard Historical Viewer Configuration software, the Extensive Software Package, includes the Data Acquisition Studio to provide Real Time Access from one to multiple PPS units (2,048 tags) via LAN or serial Modbus.
- Provides data logging functions within the software in the PC.
- The software allows real time viewing of standard screen views from specific PPS recorders, to download data log files and download/upload configuration files to the recorder via the LAN or serial Modbus.
- The PPS Data Acquisition Studio is fee based and requires a hardware dongle to be inserted into one of the PC's USB drives to fully function. Without the hardware dongle, the software may be installed and run for 1-hour and then it will stop functioning.

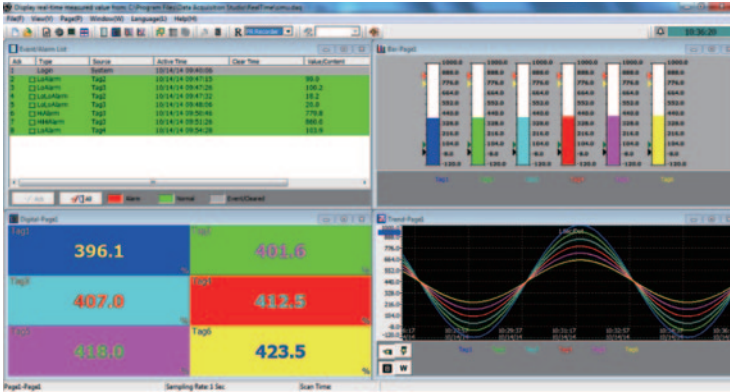

Real Time Viewer on the PC

Rear Panel Layout



PPS-1000

4 slots, up to 6 Analog inputs



PPS-2000

4 slots, up to 24 Analog inputs



PPS-3000

16 slots, up to 48 Analog inputs

Portables

The portable version of the PPS Series is supplied with a handle, 120VAC cordset, and rear mounted Power Switch.



PPS-1000

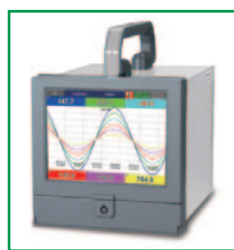

PPS-2000

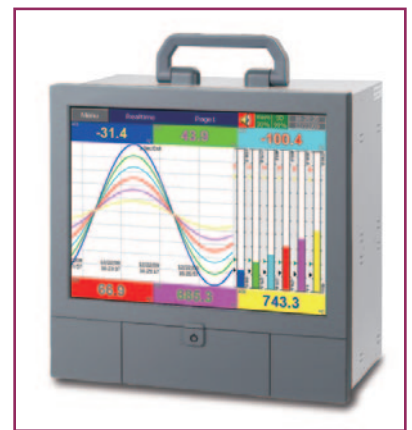

PPS-3000

Dimensional Specifications: mm (in)

PPS-1000

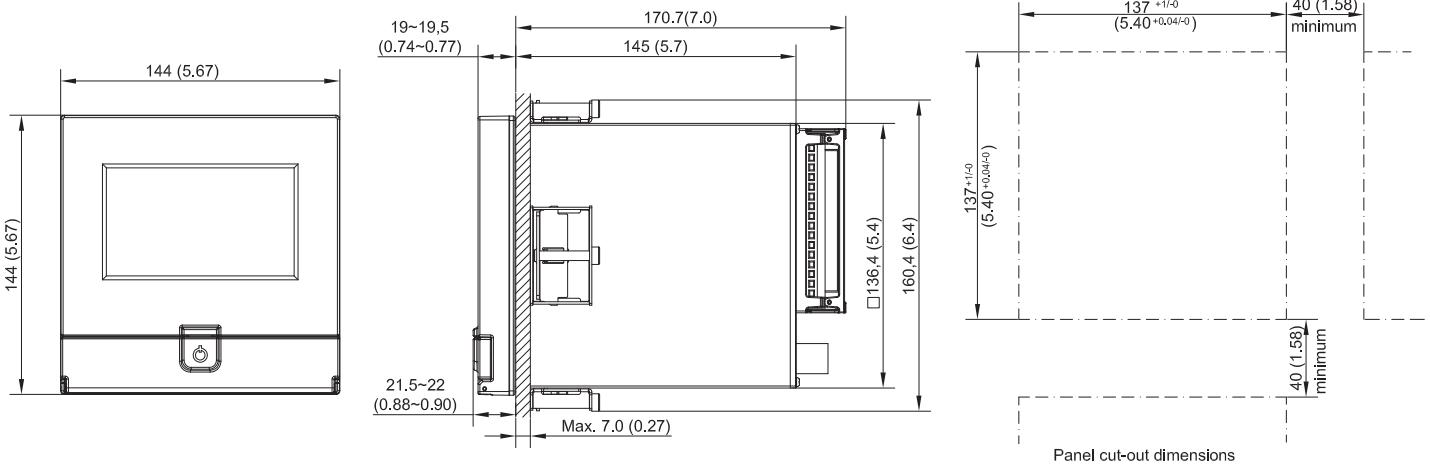

PPS-2000

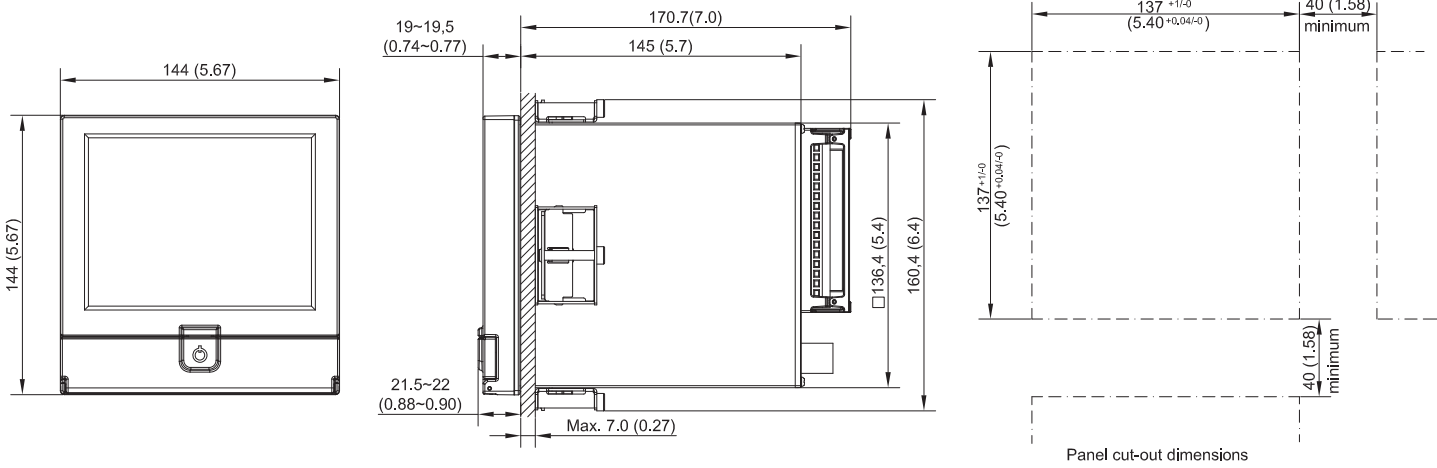

PPS-3000

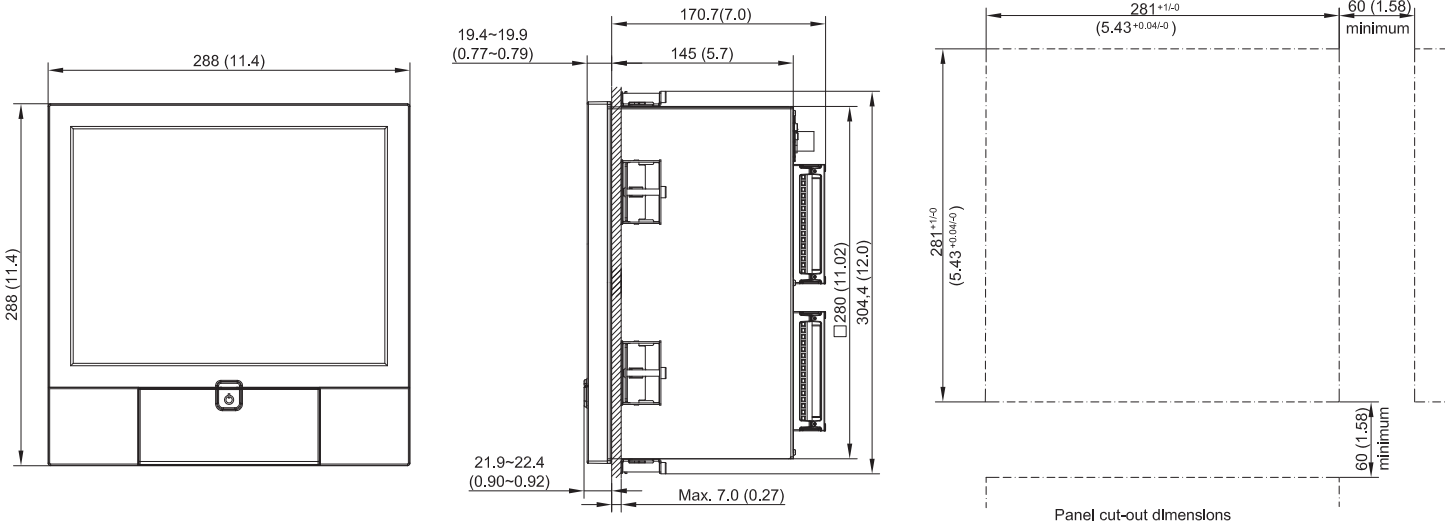

PPS-2000 Ordering Information

Ordering Code: **PPS-2000** -

Analog Inputs BOX 1
03 = 3 Analog Input Channels

I/O Options BOX 2
0 = None
6 = 3 Relay Outputs and 3 Digital Inputs
C = 3 Relay Outputs and 3 Digital Inputs and 6 Analog Outputs

Analog Inputs BOX 1
06 = 6 Analog input Channels

I/O Options BOX 2
0 = None
1 = 6 Relay Outputs
3 = 6 Digital Inputs
5 = 6 Analog Outputs
6 = 3 Relay Outputs and 3 Digital Inputs
7 = 6 Relay Outputs and 6 Digital Inputs
A = 6 Relay Outputs and 6 Analog Output
B = 6 Digital Inputs and 6 Analog Outputs
C = 3 Relay Outputs and 3 Digital Inputs and 6 Analog Outputs
D = 6 Relay Outputs and 6 Digital Inputs and 6 Analog Outputs

Analog Inputs BOX 1
12 = 12 Analog input Channels

I/O Options BOX 2
0 = None
1 = 6 Relay Outputs
2 = 12 Relay Outputs
3 = 6 Digital Inputs
4 = 12 Digital Outputs
5 = 6 Analog Outputs
6 = 3 Relay Outputs and 3 Digital Inputs
7 = 6 Relay Outputs and 6 Digital Inputs
8 = 9 Relay Outputs and 3 Digital Inputs
9 = 3 Relay Outputs and 9 Digital Inputs
A = 6 Relay Outputs and 6 Analog Outputs
B = 6 Digital Inputs and 6 Analog Outputs
C = 3 Relay Outputs and 3 Digital Inputs and 6 Analog Outputs

Analog Inputs BOX 1
18 = 18 Analog input Channels

I/O Options BOX 2
0 = None
1 = 6 Relay Outputs
3 = 6 Digital Inputs
5 = 6 Analog Outputs
6 = 3 Relay Outputs and 3 Digital Inputs

Analog Inputs BOX 1
24 = 24 Analog input Channels

I/O Options BOX 2
0 = None

Power BOX 3
A = 90 - 250 VAC, 50 - 60 Hz
D = 11 - 36 VDC

Data Communications BOX 4
0 = Standard Ethernet
1 = Ethernet and RS-232
2 = Ethernet RS-422/485

Firmware BOX 5
0 = Standard version
1 = Plus version 1 with extra math, external channels, batch and FDA 21 CFR part 11
2 = Plus version 2 with custom edited display and editing software Panel Studio
3 = Plus version 3 includes Plus versions 1 and 2

PC Software BOX 6
1 = Basic software includes Historical Viewer and Configuration
2 = Extensive software Data Acquisition Studio includes RealTime Viewer & Historical Viewer and Configuration

Mounting Types, Power Cord & Switch BOX 7
0 = Panel Mount, no power switch, no power cord
1 = Panel Mount, with power switch, no power cord
2 = Portable style, with UL/CSA power cord and switch
3 = Portable style, with VDE power cord and switch
4 = Portable style, with SAA power cord and switch
5 = Portable style, with BS power cord and switch

Removable Memory BOX 8
00 = None
S1 = 16G SD Card
S2 = 32G SD Card

Ordering Information

Videographic Data Recorders are offered with the options listed in the worksheet. Create an ordering code by filling in the boxes with the appropriate number and/or letter designation for your requirements and a part number will be assigned, or choose one of the basic systems.

Standard lead time is stock to 3 weeks.

WARNING: Cancer and Reproductive Harm - www.P65Warnings.ca.gov.

Basic Systems (Part Number & Description)

PPS20003 12 Analog Input Channels, no input/output, 90-250VAC Power Input, Standard Ethernet, Standard Firmware, Basic Software, Panel Mount, 16GB SD card

PPS20004 18 Analog Input Channels, no input/output, 90-250VAC Power Input, Standard Ethernet, Standard Firmware, Basic Software, Panel Mount, 16GB SD card

PPS20005 12 Analog Input Channels, 6 Digital Input and 6 Relay Outputs, 90-250VAC Power Input, Standard Ethernet, Standard Firmware, Basic Software, Panel Mount, 16GB SD card

PPS20006 18 Analog Input Channels, 3 Digital Input and 3 Relay Outputs, 90-250VAC Power Input, Standard Ethernet, Standard Firmware, Basic Software, Panel Mount, 16GB SD card



PPS-3000 Ordering Information

Ordering Code: **PPS-3000** - ¹ ² ³ ⁴ ⁵ ⁶ ⁷ ⁸ ⁹ ¹⁰

Analog Inputs BOX 1

- 06** = 6 Analog Input Channels
- 12** = 12 Analog Input Channels
- 18** = 18 Analog Input Channels
- 24** = 24 Analog Input Channels
- 30** = 30 Analog Input Channels
- 36** = 36 Analog Input Channels
- 42** = 42 Analog Input Channels
- 48** = 48 Analog Input Channels

Analog Outputs BOX 4

- 0** = None
- 1** = 6 Analog Outputs
- 2** = 12 Analog Outputs

PC Software BOX 8

- 1** = Basic software includes Historical Viewer and Configuration
- 2** = Extensive software Data Acquisition Studio includes RealTime Viewer & Historical Viewer and Configuration

Relay Outputs BOX 2

- 0** = None
- 1** = 6 Output Relays
- 2** = 12 Output Relays
- 3** = 18 Output Relays
- 4** = 24 Output Relays

Power BOX 5

- A** = 90 - 250 VAC, 50 - 60 Hz
- D** = 11 - 36 VDC

Mounting Types, Power Cord & Switch BOX 9

- 0** = Panel Mount, no power switch, no power cord
- 1** = Panel Mount, with power switch, no power cord
- 2** = Portable style, with UL/CSA power cord and switch
- 3** = Portable style, with VDE power cord and switch
- 4** = Portable style, with SAA power cord and switch
- 5** = Portable style, with BS power cord and switch

Data Communications BOX 6

- 0** = Standard Ethernet
- 1** = Ethernet and RS-232
- 2** = Ethernet RS-422/485

Digital Inputs BOX 3

- 0** = None
- 1** = 6 Digital Inputs
- 2** = 12 Digital Inputs
- 3** = 18 Digital Inputs

Firmware BOX 7

- 0** = Standard version
- 1** = Plus version 1 with extra math, external channels, batch and FDA 21 CFR part 11
- 2** = Plus version 2 with custom edited display and editing software Panel Studio
- 3** = Plus version 3 includes Plus versions 1 and 2

Removable Memory BOX 10

- 00** = None
- S1** = 16G SD Card
- S2** = 32G SD Card

Ordering Information

Videographic Data Recorders are offered with the options listed in the worksheet. Create an ordering code by filling in the boxes with the appropriate number and/or letter designation for your requirements and a part number will be assigned, or choose one of the basic systems.

Standard lead time is stock to 3 weeks.

⚠ WARNING: Cancer and Reproductive Harm - www.P65Warnings.ca.gov.

Basic Systems (Part Number & Description)

PPS30001 24 Analog Input Channels, no input/output, 90-250VAC Power Input, Standard Ethernet, Standard Firmware, Basic Software, Panel Mount, 16GB SD card

PPS30002 36 Analog Input Channels, no input/output, 90-250VAC Power Input, Standard Ethernet, Standard Firmware, Basic Software, Panel Mount, 16GB SD card

PPS30003 24 Analog Input Channels, 6 Digital Input and 6 Relay Outputs, 90-250VAC Power Input, Standard Ethernet, Standard Firmware, Basic Software, Panel Mount, 16GB SD card

PPS30004 36 Analog Input Channels, 6 Digital Input and 6 Relay Outputs, 90-250VAC Power Input, Standard Ethernet, Standard Firmware, Basic Software, Panel Mount, 16GB SD card



PPS-1000 Ordering Information

Ordering Code: **PPS-1000** - ¹ ⁸

Analog Inputs BOX 1
03 = 3 Analog Input Channels

I/O Options BOX 2
0 = None
6 = 3 Relay Outputs and 3 Digital Inputs

Analog Inputs BOX 1
06 = 6 Analog input Channels

I/O Options BOX 2
0 = None
1 = 6 Relay Outputs
3 = 6 Digital Inputs
6 = 3 Relay Outputs and 3 Digital Inputs
7 = 6 Relay Outputs and 6 Digital Inputs

PC Software BOX 6

- 1** = Basic software includes Historical Viewer and Configuration
- 2** = Extensive software Data Acquisition Studio includes RealTime Viewer & Historical Viewer and Configuration

Power BOX 3
A = 90 - 250 VAC, 50 - 60 Hz
D = 11 - 36 VDC

Firmware BOX 5
0 = Standard version
1 = Plus version 1 with extra math, external channels, batch and FDA 21 CFR part 11
2 = Plus version 2 with custom edited display and editing software Panel Studio
3 = Plus version 3 includes Plus versions 1 and 2

Mounting Types, Power Cord & Switch BOX 7

- 0** = Panel Mount, no power switch, no power cord
- 1** = Panel Mount, with power switch, no power cord
- 2** = Portable style, with UL/CSA power cord and switch
- 3** = Portable style, with VDE power cord and switch
- 4** = Portable style, with SAA power cord and switch
- 5** = Portable style, with BS power cord and switch

Data Communications BOX 4
0 = Standard Ethernet
1 = Ethernet and RS-232
2 = Ethernet RS-422/485

Removable Memory BOX 8
00 = None
S1 = 16G SD Card
S2 = 32G SD Card

Ordering Information

Videographic Data Recorders are offered with the options listed in the worksheet. Create an ordering code by filling in the boxes with the appropriate number and/or letter designation for your requirements and a part number will be assigned, or choose one of the basic systems.

Standard lead time is stock to 3 weeks.

⚠ WARNING: Cancer and Reproductive Harm - www.P65Warnings.ca.gov.

Basic Systems (Part Number & Description)

PPS10001 3 Analog Input Channels, no input/output, 90-250VAC Power Input, Standard Ethernet, Standard Firmware, Basic Software, Panel Mount, 16GB SD card

PPS10003 3 Analog Input Channels, 3 Digital Input and 3 Relay Outputs, 90-250VAC Power Input, Standard Ethernet, Standard Firmware, Basic Software, Panel Mount, 16GB SD card

PPS10002 6 Analog Input Channels, no input/output, 90-250VAC Power Input, Standard Ethernet, Standard Firmware, Basic Software, Panel Mount, 16GB SD card

PPS10004 6 Analog Input Channels, 3 Digital Input and 3 Relay Outputs, 90-250VAC Power Input, Standard Ethernet, Standard Firmware, Basic Software, Panel Mount, 16GB SD card

Auxillary I/O Cards/Modules and Accessories (Part Number & Description)

PPS90001 6 Analog Input Channels

PPS90004 6 Digital Inputs

PPS90002 3 Analog Input Channels

PPS90005 3 Relay Outputs and 3 Digital Inputs

PPS90003 6 Relay Outputs



PPS90006 6 Analog Outputs

PPS90050 Spare Door Key

RCR-600 6-Point 100 mm Chart Recorder



Design Features

- * 6-Channel dotting recorder
- * 100 mm chart paper size
- * 144 × 144 mm metal housing
- * Weighs only 3.3 lb. (1.5 Kg)
- * NEMA 4 / IP65 Dustproof water resistant housing
- * Universal settable input and range
- * Optional 6 alarm-relay outputs
- * Optional 3 digital inputs
- * Optional communication interface for RS-232
- * Agency approvals:  

Standard Functions

Function	Description	Function	Description
Analog Recording	Makes analog recording with 6 colored dots.	Open Input Indication	Sets indicator at over 100% or 0% for an input.
Digital Display	Indicates channel number, process variable, date, chart speed and alarm setpoint.	Tag Number	Sets a tag number by 7 figures every channel.
Logging Print	Prints date, time, scaling, chart speed, process variable, and engineering unit at a programmed interval.	Copy Function	Copies a channel setup.
List Print	Prints chart speed, sensor type, measurement range, engineering unit, alarm setting value comment, printing description, logging print and on/off zone.	Setting Input Offset	Setting input offset is possible for every channel.
Affix Print	Prints channel number by the analog recording.	Zone Recording	Specifies a recording area for every channel to separate into tracks.
Dot Print Skip	Skips recording of an unused channel.	Alarm Print	Prints occurrence time, occurrence channel, setting number, and alarm type in purple at occurrence of alarm.
Programming	Programs chart speed, alarm setting value, logging, dot point skip, date and time.	Alarm Recovery Print	Prints recovery time, recovery channel, setting number, and alarm type in purple at recovering of an alarm.
Memory	A built-in lithium battery protects the clock function backup.	Alarm Hysteresis	Sets an alarm hysteresis width 0% full scale or 0.5% full scale.
Alarm	Sets 2 types—high and low—per channel for a total of 4 levels.		
Clock	Indicates year, month, day, hour and minute.		
Self Diagnostics	Indicates “Error” and code when there is a fault.		

Specifications & Features – RCR-600 Chart Recorder

DESIGN SPECIFICATIONS

Input Signal

Thermocouple: J, K, T, E, B, S, R, C, N, U, L, Au-Fe

RTD: PT100, JPT100

DC Voltage: ±10mV, 0-20mV, 0-50mV, ±1V, 1-5V

Current: 4-20 mA dc, with external 250W shunt resistor

Performance

Recording Width: 100 mm calibrated

Recording Accuracy: ±0.2%; ±1 digit maximum for display / printing

Input Impedance: mV/tc input - 10MΩ

Vdc input - 1MΩ, mA input - 100Ω

Common Mode Rejection Ratio (CMRR): 140 db

Normal Mode Rejection Ratio (NMRR): 60 db

Dielectric Strength: Power input/ground - 1500 Vac

Input/ground - 500 Vac

Vibration Resistance: 1 m/s² maximum 10 - 60 Hz

Shock Resistance: 2 m/s² maximum

Chart Feed Accuracy: ±0.1% maximum

Clock Precision: ±50 ppm

Power Source

Power Input: 85 to 264 Vac

Frequency: 45 to 65 Hz

Power Consumption: 30 VA

Recording and Printing

Recording: Raster-scan printing

Printing: Dotting with 6-color ribbon

Dot Print Interval: 10.0 second / 6 channel maximum

Chart Paper: Length - 52.5 ft. (16m)

Chart Speed: 28 speeds, user selectable, from 10-1500 mm/hr

Printing Colors: Purple, red, green, blue, brown, black

Alarm – Input/Output

Outputs: 1 relay drive per setting, up to 6 relays
250 Vac 3A/ 30Vdc 3A/ 125Vdc 0.5A

Quantity per Channel: 4

Digital Inputs: Maximum of 3

Normal Operating Conditions

Ambient Temperature: 32° to 122°F (0° to 50°C)

Relative Humidity: 35 to 85%, non-condensing

Communications

Standard: RS-232C

Optional: RS-485 (Modbus RTU)

Structure

Dimensions: 144 × 144 × 175 mm (5.7" × 5.7" × 6.9")

Mounting: Panel mount, allowable inclination – 30°

Panel Cutout: 138 × 138 mm (5.43" × 5.43")

Ordering Code: **RCR-600** -

Digital input / output BOX 1

0 = None

1 = 6 Relay output

2 = 3 Digital inputs

3 = 3 Digital inputs + 6 relay outputs

Data Communications BOX 3

0 = RS - 232C Interface

1 = RS - 485 Interface

Out of Paper Sensor BOX 2

0 = None

1 = Yes

Ordering Information

The **RCR-600** is offered with the options listed in the worksheet. Create an ordering code by filling in the boxes with the appropriate number and/or letter designation for your requirements and a part number will be assigned, or choose one of the basic systems.

Standard lead time is stock to 4 weeks.

⚠ WARNING: Cancer and Reproductive Harm - www.P65Warnings.ca.gov.

Basic Systems

Part Number	Description
RCR40001	6-point dotting, 6 relay/digital outputs, no out of paper sensor, with RS-232C data interface
RCR40002	6-point dotting, no relay/digital outputs, no out of paper sensor, with RS-232C data interface
RCR40003	6-point dotting, 6 relay/digital outputs & 3 digital inputs, no out of paper sensor, with RS-232C data interface
RCR40005	6-point dotting, 6 relay outputs, has out of paper sensor, with RS-232C data interface

Accessories – RCR-600

Part Number	Description
RCA40901	Chart paper – Z fold style, 52.5 ft. (16 m)
RCA40902	Replacement Multi-Color Ribbon
RCA40903	Precision Shunt Resistor, 250W

Rotating Multi-Pin Electrical Connectors

Do you want a superior connection or an ordinary slip ring assembly?

Choose TEMPCO's Rotating Electrical Connectors for Higher Operating Efficiencies . . .

Design Features

- * Superior to conventional slip rings
- * Extremely low electrical noise
- * Less than 1 milliohm resistance
- * Sealed, ball bearing construction
- * Increased reliability, no maintenance
- * Durable, compact, low cost

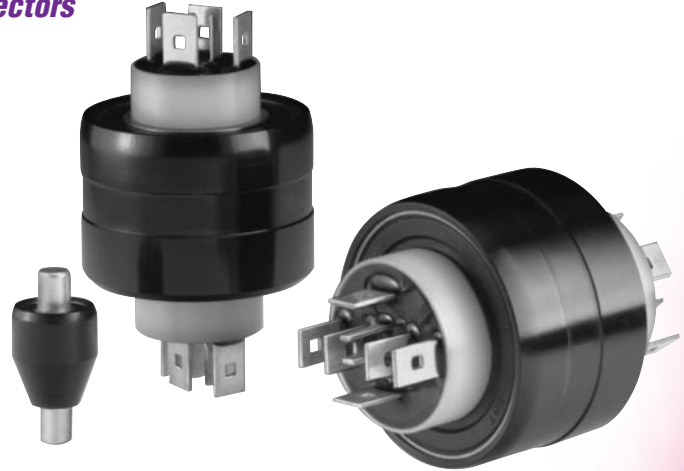

Multi-Pin Rotating Connectors Offer Superior Performance

Slip rings require maintenance and lose signal quality over time due to wear and debris on the brushes and commutator. **Tempco's Rotating Electrical Connectors** are maintenance free. They last much longer than slip ring assemblies, and the signal does not degrade over time.

Slip rings introduce electrical noise into the signal being transmitted, as shown on the oscilloscope below. **Tempco's Rotating Electrical Connectors** transmit with near zero electrical noise, so the same connector style can be used for power and signal transmission, saving money.

Slip rings typically last for a few million revolutions. **Tempco's Rotating Electrical Connectors** typically last hundreds of millions of revolutions. In many applications they can last over a billion revolutions.

The superior performance of **Tempco's Rotating Electrical Connectors** is attributable to the unique design of the connector. The electrical conduction path is a liquid metal that is molecularly bonded to the contacts. This creates a connection that is constant and unchanged for the life of the connector.

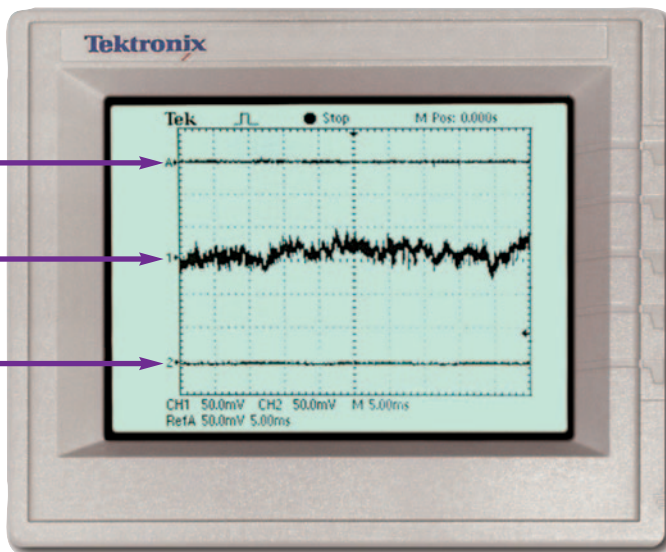

Typical Applications

- ➔ Heating Elements
- ➔ Lamps
- ➔ Thermocouples
- ➔ Signs
- ➔ Rotating Antennas
- ➔ Displays
- ➔ Turntables
- ➔ Packaging Equipment
- ➔ Cable Reels
- ➔ Robotics
- ➔ Instrumentation
- ➔ Strain Gauges
- ➔ Testing and Control Devices
- ➔ Heated Rollers

Ordering Information

Order by the part number of the rotating connector and accessories that match your requirements.

Standard lead time is stock to 4 weeks.

⚠ WARNING: Cancer and Reproductive Harm - www.P65Warnings.ca.gov.

SINGLE CONDUCTOR

1 Conductor, 10 Amp

Model 110

Part No.	Conductors	Description	VOLTAGE AC/DC	AMP RATING AT 240 VAC	MAX FREQ. MHz	CONTACT RESISTANCE	MAX OP. RPM	TEMPERATURE Max.F(C) / Min.F(C)	ROTATION Torque (gm-cm)	CIRCUIT SEPARATION
MER00110	1	Standard Model	N/A	10	200	<1mΩ	3600	140(60)/-20(-29)	35	N/A
MER00112	1	Stainless Steel Bearing	N/A	10	200	<1mΩ	3600	140(60)/-20(-29)	35	N/A
MER00113	1	Low Torque	N/A	10	200	<1mΩ	1200	140(60)/-20(-29)	10	N/A

ACCESSORIES



MER90002 one-contact receptacle



MER90003 one-contact receptacle w/ 6" wire



MER90004 ring terminal (12-10 AWG)

MER90001 one-contact cap w/solder lug

Receptacle used for mounting to rotating device.
Accessories required for wire connections. Order separately.

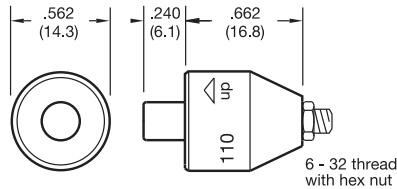

Inch (mm)



1 Conductor, 10 Amp

Model 110-T

Part No.	Conductors	Description	VOLTAGE AC/DC	AMP RATING AT 240 VAC	MAX FREQ. MHz	CONTACT RESISTANCE	MAX OP. RPM	TEMPERATURE Max.F(C) / Min.F(C)	ROTATION Torque (gm-cm)	CIRCUIT SEPARATION
MER00111	1	Standard Model	N/A	10	200	<1mΩ	3600	140(60)/-20(-29)	35	N/A
MER00115	1	Stainless Steel Bearing	N/A	10	200	<1mΩ	3600	140(60)/-20(-29)	35	N/A
MER00114	1	Low Torque	N/A	10	200	<1mΩ	1200	140(60)/-20(-29)	10	N/A

ACCESSORIES



MER90002 one-contact receptacle



MER90003 one-contact receptacle w/ 6" wire

MER90001 one-contact cap w/ solder lug

Receptacle used for mounting to rotating device.
Accessories required for wire connections. Order separately.

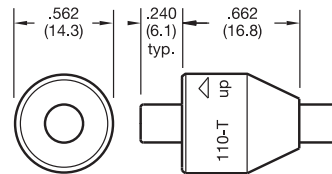

Inch (mm)



1 Conductor, 250 Amp

Model 1250

Part No.	Conductors	Description	VOLTAGE AC/DC	AMP RATING AT 240 VAC	MAX FREQ. MHz	CONTACT RESISTANCE	MAX OP. RPM	TEMPERATURE Max.F(C) / Min.F(C)	ROTATION Torque (gm-cm)	CIRCUIT SEPARATION
MER01250	1	Standard Model	N/A	250	200	<1mΩ	1200	140(60)/-20(-29)	250	N/A
MER01251	1	Stainless Steel Bearing	N/A	250	200	<1mΩ	1200	140(60)/-20(-29)	250	N/A
MER01252	1	Metric Thread (10x1.5)	N/A	250	200	<1mΩ	1200	140(60)/-20(-29)	250	N/A
MER01253	1	Metric Thread & Stainless Steel Bearing	N/A	250	200	<1mΩ	1200	140(60)/-20(-29)	250	N/A
MER01254	1	Stainless Steel Body & Bearing	N/A	250	200	<1mΩ	1200	140(60)/-20(-29)	250	N/A
MER01255	1	Metric Thd., Stainless Steel Body & Bearing	N/A	250	200	<1mΩ	1200	140(60)/-20(-29)	250	N/A

ACCESSORIES



MER90106
Boot Kit
For dust and splash protection
IP51

Inch (mm)

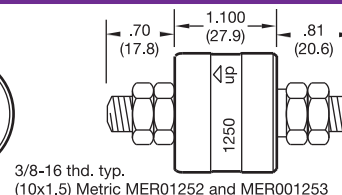
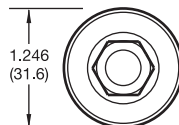

Rotating Electrical Connectors

2 & 3 CONDUCTORS

2 Conductors, 4 Amp

Model 205

Part No.	Conductors	Description	VOLTAGE AC/DC	AMP RATING AT 240 VAC	MAX FREQ. MHz	CONTACT RESISTANCE	MAX OP. RPM	TEMPERATURE Max.F(C) / Min.F(C)	ROTATION Torque (gm-cm)	CIRCUIT SEPARATION
MER00205	2	Standard Model	0-250	4	200	<1mΩ	2000	140(60)/45(7)	75	>25MΩ
MER00208	2	Stainless Steel Bearing	0-250	4	200	<1mΩ	2000	140(60)/45(7)	75	>25MΩ
MER00207	2	Low Torque/Low Temp.	0-250	4	200	<1mΩ	1200	140(60)/-20(-29)	20	>25MΩ
MER00210	2	Low Temp. Stainless Steel Bearing	0-250	4	200	<1mΩ	1200	140(60)/-20(-29)	75	>25MΩ
MER00206	2	High RPM	0-250	4	200	<1mΩ	3600	140(60)/45(7)	35	>25MΩ
MER00209	2	High RPM Stainless Steel Bearing	0-250	4	200	<1mΩ	3600	140(60)/45(7)	35	>25MΩ

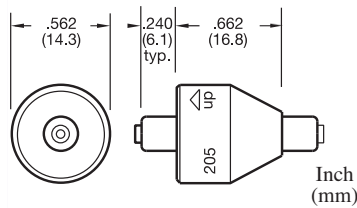

ACCESSORIES

MER90015 two-contact receptacle w/ one 6" wire

MER90005 two-contact receptacle w/ two 6" wires

MER90007 two-contact cap w/ solder lugs

MER90006 two-contact receptacle w/ two solder holes

Receptacle used for mounting to rotating device.
Accessories required for wire connections. Order separately.

2 Conductors, 30 Amp

Model 230

Part No.	Conductors	Description	VOLTAGE AC/DC	AMP RATING AT 240 VAC	MAX FREQ. MHz	CONTACT RESISTANCE	MAX OP. RPM	TEMPERATURE Max.F(C) / Min.F(C)	ROTATION Torque (gm-cm)	CIRCUIT SEPARATION
MER00230	2	Standard Model	0-250	30	200	<1mΩ	1800	140(60)/-20(-29)	200	>25MΩ
MER00231	2	Stainless Steel Bearing	0-250	30	200	<1mΩ	1800	140(60)/-20(-29)	200	>25MΩ

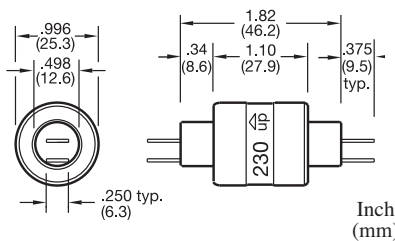

Includes (2) MER90009 and (2) MER90010

ACCESSORIES

MER90010 Terminal 16-14 AWG

MER90101 Boot Kit

For dust and splash protection IP51

MER90009 Terminal 16-14 AWG

Terminals for other wire gauges available.

3 Conductors, 4 Amp

Model 305

Part No.	Conductors	Description	VOLTAGE AC/DC	AMP RATING AT 240 VAC	MAX FREQ. MHz	CONTACT RESISTANCE	MAX OP. RPM	TEMPERATURE Max.F(C) / Min.F(C)	ROTATION Torque (gm-cm)	CIRCUIT SEPARATION
MER00305	3	Stainless Steel Bearing Standard	0-250	4	200	<1mΩ	1800	140(60)/45(7)	100	>25MΩ
MER00316	3	Low Temperature	0-250	4	200	<1mΩ	1000	140(60)/-20(-29)	100	>25MΩ

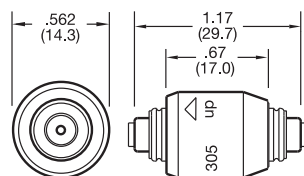

Inch (mm)

ACCESSORIES

MER90014 three-contact receptacle w/ three 6" wires

MER90013 three-contact cap w/ solder lugs

Receptacle used for mounting to rotating device.
Accessories required for wire connections. Order separately.

3 & 4 CONDUCTORS

3 Conductors, Combination 4 Amp & 30 Amp

Model 331

Part No.	Conductors	Description	VOLTAGE AC/DC	AMP RATING AT 240 VAC	MAX FREQ. MHz	CONTACT RESISTANCE	MAX OP. RPM	TEMPERATURE Max.F(C) / Min.F(C)	ROTATION Torque (gm-cm)	CIRCUIT SEPARATION
MER00331	3	Standard Model	0-250	2@4/1@30	100	<1mΩ	1800	140(60)/-20(-29)	200	>25MΩ
MER00333	3	Stainless Steel Bearing	0-250	2@4/1@30	100	<1mΩ	1800	140(60)/-20(-29)	200	>25MΩ

ACCESSORIES



MER90010
Terminal
16-14 AWG



MER90009 Terminal
16-14 AWG



MER90101
Boot Kit
For dust and splash protection
IP51



MER90008 Terminal
22-18 AWG

Terminals for other wire gauges available.

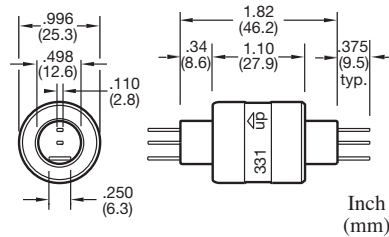

Includes (1) MER90010,
(1) MER90009 and (4) MER90008



3 Conductors, 30 Amp

Model 330

Part No.	Conductors	Description	VOLTAGE AC/DC	AMP RATING AT 240 VAC	MAX FREQ. MHz	CONTACT RESISTANCE	MAX OP. RPM	TEMPERATURE Max.F(C) / Min.F(C)	ROTATION Torque (gm-cm)	CIRCUIT SEPARATION
MER00330	3	Standard Model	0-250	30	100	<1mΩ	1200	140(60)/-20(-29)	300	>25MΩ
MER00332	3	Stainless Steel Bearing	0-250	30	100	<1mΩ	1200	140(60)/-20(-29)	300	>25MΩ

ACCESSORIES



MER90010
Terminal
16-14 AWG



MER90021
Shrink Tube



MER90102
Boot Kit
For dust and splash protection
IP51



MER90019
Terminal 16-14 AWG

Terminals for other wire gauges available.

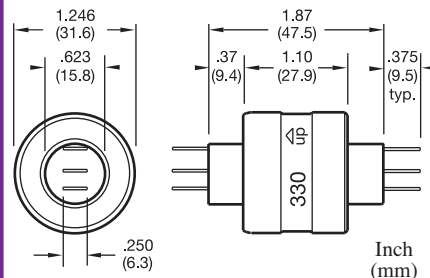

Includes (3) MER90010,
(3) MER90019 and (3) MER90021



4 Conductors, Combination 4 Amp & 30 Amp

Model 430

Part No.	Conductors	Description	VOLTAGE AC/DC	AMP RATING AT 240 VAC	MAX FREQ. MHz	CONTACT RESISTANCE	MAX OP. RPM	TEMPERATURE Max.F(C) / Min.F(C)	ROTATION Torque (gm-cm)	CIRCUIT SEPARATION
MER00430	4	Standard Model	0-250	2@4/2@30	100	<1mΩ	1200	140(60)/-20(-29)	400	>25MΩ
MER00431	4	Stainless Steel Bearing	0-250	2@4/2@30	100	<1mΩ	1200	140(60)/-20(-29)	400	>25MΩ

ACCESSORIES



MER90022 Plug Assembly
12-in. wires, 14 AWG & 18 AWG
SUITABLE FOR UP TO 20 AMPS



MER90010
16-14 AWG



MER90009, 16-14 AWG



MER90102
Boot Kit
For dust and splash protection
IP51



MER90008, 22-18 AWG

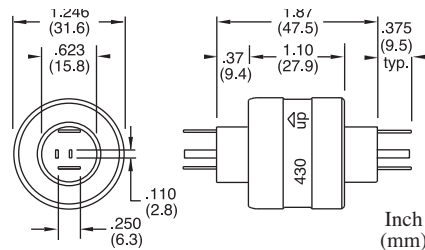

Includes (2) MER90009,
(2) MER90010 and (4) MER90008



4, 6 & 8 CONDUCTORS

4 Conductors, 30 Amp, High Voltage

Model 435

Part No.	Conductors	Description	VOLTAGE AC/DC	AMP RATING AT 500 VAC	MAX FREQ. MHz	CONTACT RESISTANCE	MAX OP. RPM	TEMPERATURE Max.F(C) / Min.F(C)	ROTATION Torque (gm-cm)	CIRCUIT SEPARATION
MER00435	4	High Voltage Model	0-500	30	100	<1mΩ	300	140(60)/-20(-29)	850	>50MΩ
MER00436	4	High Voltage Stainless Steel Bearing	0-500	30	100	<1mΩ	300	140(60)/-20(-29)	850	>50MΩ

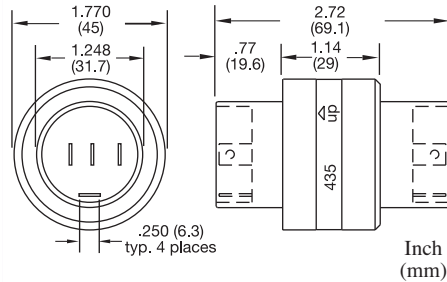

Includes (4) MER90009 and (4) MER90010

ACCESSORIES



MER90009
Terminal 16-14 AWG



MER90010
Terminal 16-14 AWG



MER90103
Boot Kit
For dust and splash protection
IP51

Terminals for other wire gauges available.

6 Conductors, Combination 4 Amp & 30 Amp

Model 630

Part No.	Conductors	Description	VOLTAGE AC/DC	AMP RATING AT 240 VAC	MAX FREQ. MHz	CONTACT RESISTANCE	MAX OP. RPM	TEMPERATURE Max.F(C) / Min.F(C)	ROTATION Torque (gm-cm)	CIRCUIT SEPARATION
MER00630	6	Standard Model	0-250	2@4/4@30	100	<1mΩ	300	140(60)/-20(-29)	700	>25MΩ
MER00631	6	Stainless Steel Bearing	0-250	2@4/4@30	100	<1mΩ	300	140(60)/-20(-29)	700	>25MΩ

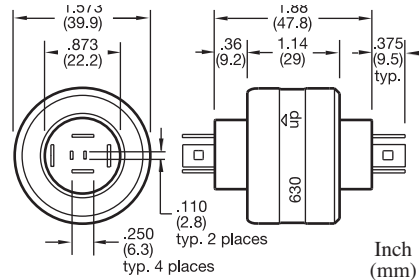

Includes (4) MER90008, (4) MER90010, (4) MER90019 and (4) MER90021

ACCESSORIES



MER90008
Terminal 22-18 AWG



MER90021
Shrink Tube



MER90019
Terminal 16-14 AWG



MER90010
Terminal 16-14 AWG



MER90104
Boot Kit
For dust and splash protection
IP51

Terminals for other wire gauges available.

8 Conductors, Combination 4 Amp & 30 Amp

Model 830

Part No.	Conductors	Description	VOLTAGE AC/DC	AMP RATING AT 240 VAC	MAX FREQ. MHz	CONTACT RESISTANCE	MAX OP. RPM	TEMPERATURE Max.F(C) / Min.F(C)	ROTATION Torque (gm-cm)	CIRCUIT SEPARATION
MER00830	8	Standard Model	0-250	2@4/6@30	100	<1mΩ	200	140(60)/-20(-29)	1000	>25MΩ
MER00831	8	Stainless Steel Bearing	0-250	2@4/6@30	100	<1mΩ	200	140(60)/-20(-29)	1000	>25MΩ

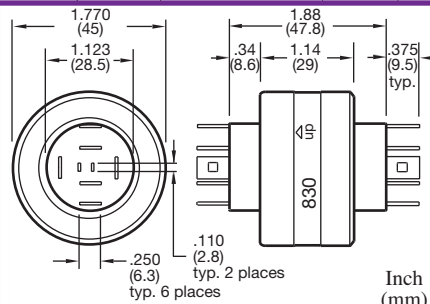

Includes (4) MER90008, (6) MER90010, (6) MER90019 and (6) MER90021

ACCESSORIES



MER90008
Terminal 22-18 AWG



MER90021
Shrink Tube



MER90019
Terminal 16-14 AWG



MER90010
Terminal 16-14 AWG



MER90105
Boot Kit
For dust and splash protection
IP51

Terminals for other wire gauges available.

TECHNICAL INFORMATION

MOUNTING

- Rotating connectors may be used in any position between vertical and 90° horizontal. The UP arrow should not point below horizontal.
- Model 110, 110-T, 205 and 305 connectors use the knurled receptacle inserted into the rotating member for mounting. This receptacle holds the rotating connector.
- Larger rotating connectors use either the body or the plastic collar for mounting to the rotating member.
- In horizontal applications, mount the connector with the body rotating to reduce mechanical loads on the bearing.
- Limit mounting eccentricity to a maximum of .005" TIR.
- Rotating connectors are not designed to carry mechanical loads. One end should be allowed to float, attached only by the connecting wires.

CONNECTION

- Use stranded wires of ample length and flexibility for the connection in order to avoid mechanical loads.
- Terminal accessories are push-on quick disconnects which crimp onto the connecting wires and push onto the connector tabs.
- Do not solder wires to the connector or bend tabs, as such misuse will cause connector failure and void the warranty.
- Provide overload protection to the electrical circuit containing the rotating electrical connector.
- If wire wrapping occurs from too much connector torque, it is suggested to use a torque arm positioned to float against a fixed stop.

TEMPERATURE

- Provide thermal insulation where necessary to prevent the connector temperature from exceeding 140°F (60°C). Rotating electrical connectors contain plastic materials that are sensitive to heat.
- Overheating will cause connector failure and voids the warranty.

VIBRATION/SHOCK

- Vibration or mechanical shock will reduce connector life or cause failure.
- If vibration or shock is present, we suggest a flexible isolating mounting.

FOOD APPLICATIONS

- Rotating electrical connectors are factory sealed but do contain mercury and other fluids.
- As a precaution, a protective housing is suggested to isolate the rotating connector from the food product.

BOOT KIT

- The boot kit is not watertight or intended for waterproofing but is designed to give protection to the wire terminals from splashing water or dust. The protection rating is IP51.

RECYCLING

Rotating electrical connectors contain mercury and should not be disposed of in the trash but only through mercury recycling programs. Tempco offers a mercury recycling service for this purpose. Ship spent connectors to our facility by UPS ground enclosed in a plastic bag. Include paperwork stating "for recycling" with your company name, phone and fax numbers. Do not send through the U.S. Mail.

Suggested Mounting Methods

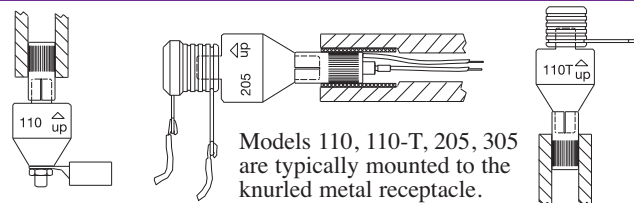

Models 110, 110-T, 205, 305 are typically mounted to the knurled metal receptacle.

Receptacle Mount Hole Dimensions

MODEL	HOLE DIAMETER Ø	DEPTH
591, 592, 5920, 594	.283" (7.19)	.35" (8.89)
593	.408 (10.36)	.35" (8.89)

Inch (mm) Tolerances Ø $+0.01" (+0.25)$
 $-0.00" (-0.00)$

Typical Body Mount

Body Mount Hole Dimensions

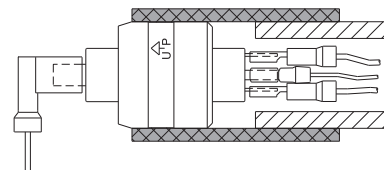

MODEL	HOLE DIAMETER Ø	DEPTH*
230, 331	.998" (25.35)	.80" (20)
330, 430, 1250	1.248" (31.70)	.80" (20)
630	1.575" (40.00)	.80" (20)
435, 830	1.772" (45.00)	.80" (20)

Inch (mm) Tolerances Ø $+0.01" (+0.25)$
 $-0.00" (-0.00)$

*Minimum additional depth for disconnect clearance is 1.4" (35.5).

Typical Collar Mount

Collar Mount Hole Dimensions

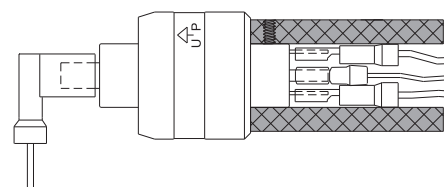

MODEL	HOLE DIAMETER Ø	DEPTH*
230, 331	.500" (12.70)	.40" (10)
330, 430	.625" (15.88)	.40" (10)
430 w/ plug	.625" (15.88)	1.40" (36)
630	.875" (22.23)	.40" (10)
830	1.125" (28.58)	.40" (10)
435	1.250" (31.75)	.80" (20)
1250 Stud	3/8"-16 UNC	.81" (20.5)
1250-metric Stud	10 x 1.5 metric	.81" (20.5)

Inch (mm) Tolerances Ø $+0.01" (+0.25)$
 $-0.00" (-0.00)$

*Minimum additional depth for disconnect clearance is 1.4" (35.5).

Insulating Collar Mount

Mounting with an insulating collar may be required to insulate connector from conducted heat. Soft-mounting with rubber type material is needed if unit will be subjected to vibration.

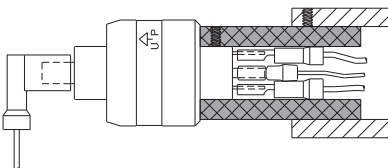

INTRODUCTION TO

Melt Pressure Transducers

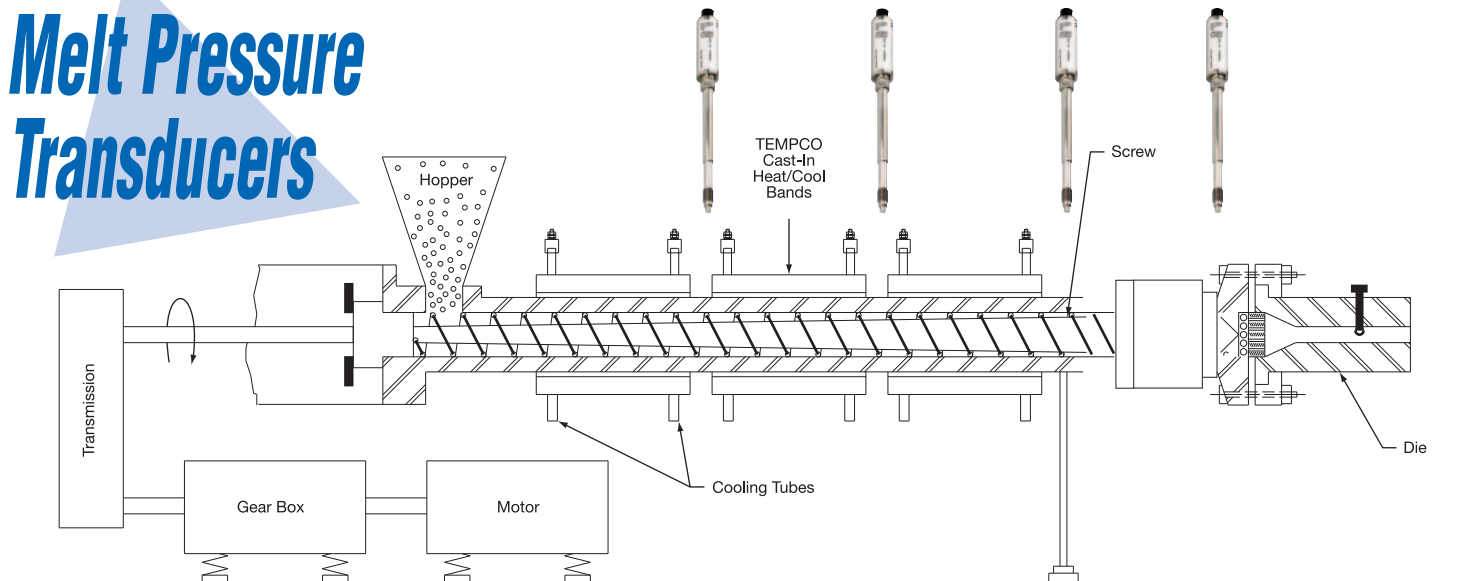

Designed for Maximum Operating Efficiency

Tempco Melt Pressure Transducers are used to sense the pressure associated with the extrusion processing of plastic materials. They range in pressure from 0-500 PSI to 0-20,000 PSI with temperatures in the range of 70-750°F. Typical transducer outputs are 3.3 mV/V, 4-20 mA, 0-5 V, or 0-10 V (at full scale output).

APPLICATION

Plastic materials are formed to shape by a process defined as extrusion. This is accomplished by first softening the material with heat. Through the use of a drive screw, which is rotated by a motor, the material is forced toward and then through an opening, called a die, used to shape the plastic melt.

Various compounds, colorants and additives can be mixed with the plastic materials as they move along the screw path. The heated materials are shaped by the die and/or other post-extrusion equipment and then cooled to retain their shape.

WHERE AND WHY TRANSDUCERS ARE USED

Melt pressure transducers can be effectively used along many points of the extrusion process for a variety of reasons:

1. From a **quality control viewpoint**, a transducer should be located in the die. The measurement of the melt pressure at this point is used as an indication of flow rate.
2. To indicate when a **screen is in need of changing** and also to insure the safety of personnel and equipment alike, a transducer will be located somewhere ahead of the screen changer. This is most likely located either in the adapter or along the screw path within the barrel. An even more accurate determination of screen plugging can be made by reading the differential pressure between transducers located on either side of the screen, one being in the adapter, the other located in the barrel ahead of the screw tip.
3. For **research and development** purposes, Tempco transducers should be located at various points along the barrel in order to accurately monitor the pressure and mixing characteristics of the melt.
4. Transducers are also used for **pressure sensing on post-extrusion equipment** such as blow-molding heads, extrusion pumps and spinnerettes.
5. Locating transducers anywhere along the apparatus also serves to **improve the safety** of the extruder.

END PRODUCTS OF EXTRUSION PROCESS

The end results of the extrusion process can be found in various products. Some examples include:

1. The feedstock for other plastic packaging systems used for compounding and mixing.
2. Plastic film used to create bags and packaging materials.
3. Plastic tubing, hose, and pipe to contain water, gases or chemicals.
4. Insulated cable and wire housing.
5. Filaments used to create textiles, brushes, rope and twine.

Melt Pressure Transducer Data

Transducer and Gauge Standard Material Diaphragm and Options

The standard Tempco transducer diaphragm is machined out of a single piece of type 15-5 PH stainless steel (.0045") and then heat treated and finally Armoloy coated. This material gives Tempco transducers the transverse strength and toughness needed for most standard applications.

There are, however, certain extrusion processes that require different types of diaphragm materials and/or coatings. Tempco is able to supply customers with diaphragms and coatings specifically suited to their needs and applications.

HASTELLOY® TIP AND DIAPHRAGM

This option gives the transducer a Hastelloy® C-276 tip. This Hastelloy® tip extends along the stem and includes the 45° cone and threads. The diaphragm (.0045") is also manufactured of Hastelloy®. Hastelloy® should be used when the following chemicals are present in the process:

HCl	Hydrochloric Acid
HF	Hydrofluoric Acid
HBr	Hydrogen Bromide
HI	Hydrogen Iodide

For example, HCL is present when processing PVC and HF is present when processing Teflon®. If Hastelloy® is not used during these processes, the transducer diaphragm will fail prematurely due to stress cracks as a result of stress corrosion.

Recommended Use: Applications that are extremely corrosive.

SPECIAL DIAPHRAGM

Special 0.006" thick Inconel® diaphragm with a proprietary coating of Titanium Aluminum Nitride.

This special diaphragm is designed to be used in extremely abrasive environments. Superior to all other diaphragm materials for corrosion and abrasion resistance, examples of applications requiring this diaphragm option are ceramics or glass-filled nylon.

Recommended Use: Applications that are extremely abrasive.

INTERNAL RESISTANCE CALIBRATION TRACKING

An internal compensation circuit insures that the shunt calibration output will track any changes in pressure sensitivity (output) due to changes in temperature of the strain gauge housing. The simulated output, therefore, is 80%, ±0.25% of the full scale pressure output over the entire operating temperature range.

CHROMIUM NITRIDE COATED DIAPHRAGM

The chromium nitride diaphragm option gives the transducer an advantage in abusive environments. The chromium nitride offers abrasion resistance and corrosion resistance. This is due to a phenomenon called reduced skin friction. This material will also cut down on diaphragm failures due to adhesion of melt to diaphragm during the process.

There are two different versions of this diaphragm option available. The first is a standard thickness (0.0045") diaphragm made of 15-5 PH stainless steel and then coated with a 0.0002" chromium nitride coating. This version is applicable for use in any pressure range plastic extruder. The second version is a 0.0080" thick diaphragm made of 15-5 PH stainless steel coated with a 0.0002" chromium nitride coating. This version is applicable for use in plastic extruders with pressure ranges of 7,500 PSI and up.

TITANIUM NITRIDE DIAPHRAGM

The titanium nitride diaphragm is offered for its excellent abrasion resistance. Its abrasion resistance is superior to the chromium nitride coated diaphragm and like the latter diaphragm the titanium nitride diaphragm comes in two different versions. The first is a standard thickness (0.0045") diaphragm made of 15-5 PH stainless steel and then coated with a 0.0002" titanium nitride coating. This version is applicable for use in any pressure range plastic extruder. The second version is a 0.0080" thick diaphragm made of 15-5 PH stainless steel coated with a 0.0002" titanium nitride coating. This version is applicable for use in plastic extruders with pressure ranges of 7,500 PSI and up.

INTERNAL RESISTANCE CALIBRATION

Tempco strain gauge sensors rely on the small change in resistance of each strain gauge to generate an analog signal that is proportional to the applied physical input. This resistance change is generated by straining a structural element to which the gauges are attached. The same output can be accomplished by electrically offsetting the resistance of one of the strain gauges through a simple shunt resistor network. This offsetting resistance network is built into each Tempco transducer.

During manufacturing, each Tempco transducer is pressure calibrated using highly accurate pressure sources and instrumentation. The signal output versus pressure input characteristic is thereby precisely known. The internal resistance network is adjusted so that the output generated by the shunt resistor simulation method matches precisely the calibrated output of the transducer at a selected point on its calibration curve. The standard simulation value is 80% of the full range rating of each transducer but other values may be chosen.

Applications of Melt Pressure Transducers

Pressure monitoring is a fundamental quality control technique used in modern extrusion processing. Typical applications include:

Film Adaptable for either blown process or slit casting, pressure monitoring can help produce thinner, more uniform film at faster process speeds. The pressure transducer also provides primary process information helpful for maximizing productivity and minimizing start-up scrap.

Synthetic Fibers Accurate, reliable pressure monitoring helps deliver greater consistency with less waste by reducing high speed variations, even with high performance fibers.

Wire Coating Pressure monitoring right in the crosshead die where the wire is coated with plastic insulation improves throughput, quality, and profits. This process parameter has become even more important as wire take-up systems go to higher and higher speeds.

Pipe, Tubing, and Profile A basic process parameter, pressure monitoring allows tighter tolerances, improves product quality and significantly improves cost effectiveness even for complex and multi-hollow extrusion.

Melt Pressure Transducers

3 Styles of Melt Pressure Transducers for Extrusion Processing

Melt pressure transducers are specifically designed for accuracy, stability, and repeatability. They can be specified with a 0.5% or 0.25% combined error accuracy, a performance that equals or exceeds any other strain gauge melt pressure transducer on the market.

Design Features

- * *Stainless Steel Construction*
- * *Fully Interchangeable with all Existing Strain Gauge Melt Pressure Transducers*
- * *Fluid Filled System for Temperature Stability*
- * *80% Output Signal for Easy Calibration*
- * *Resistance Calibration Tracking*
- * *All Stainless Steel Construction*
- * *Armoloy-Coated Diaphragm*
- * *Compatible with all Strain Gauge Signal Conditioning & Readout Instrumentation*
- * *6- or 8-Pin Bendix Style Connectors available*
- * *CE Approved*



Rigid Stem Transducer

This model converts applied pressure at the point of measurement to a proportional voltage output signal using well established bonded strain gauge design principles. The small capillary tube, filled with a special medium, isolates sensitive strain gauges and electronics from potential thermal damage. The rigid stem makes installation fast and easy.

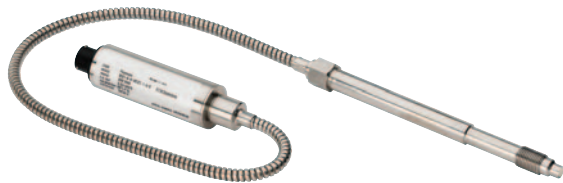
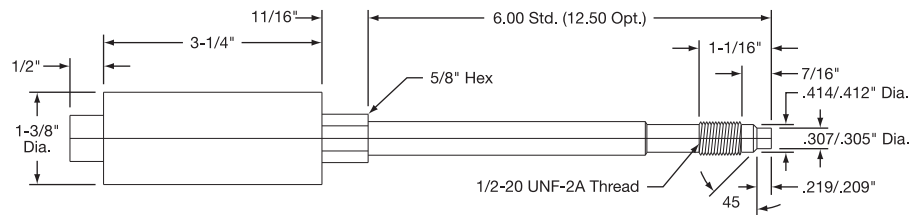

Flexible Armor Tubing Transducer

This model offers all the advantages of the rigid stem transducer, but incorporates an 18-inch flexible capillary tubing with a stainless steel armored jacket between the strain gauge housing and the stem.

This transducer is designed for applications requiring further thermal isolation or where installation would be otherwise difficult or impractical.

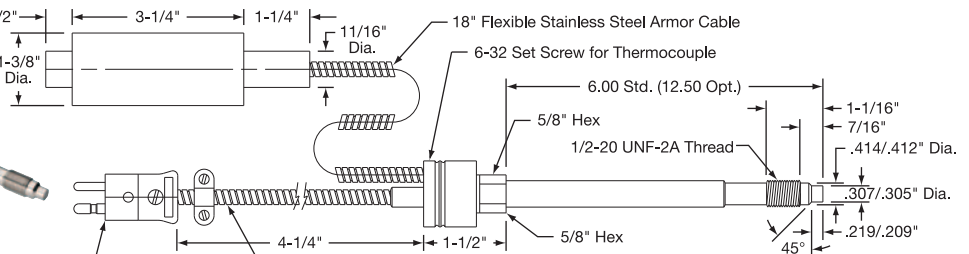
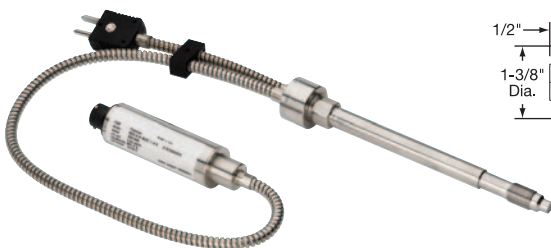
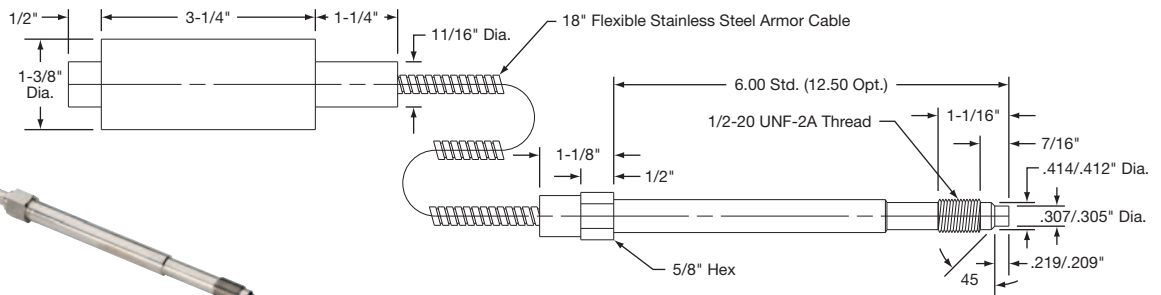

Pressure and Temperature Transducer

This model provides simultaneous measurement of pressure and temperature at a single point. Only one transducer mount is required for installation.

The temperature probe is protected from process hazards and can be replaced without interrupting the pressure signal. Pressure performance is identical to other models.

Melt Pressure Transducers for Extrusion Processing

DESIGN SPECIFICATIONS

Mechanical

Ranges

PSIG	BAR	PSIG	BAR	PSIG	BAR
0-500	0-35	0-3000	0-200	0-10000	0-700
0-750	0-50	0-5000	0-350	0-15000	0-1000
0-1000	0-70	0-7500	0-500	0-20000	0-1400
0-1500	0-100				

Combined Error/Error Band ±0.5% or ±0.25% of full-scale

Repeatability ±0.1% of full-scale

Hysteresis 0.1% of full-scale

Overload Capability Up to 20,000 PSIG: 2 × full-scale
Above 20,000 PSIG: 1.5 × full-scale

Mounting Torque 500 inch-pounds maximum

Diaphragm Material 15-5PH stn. stl. (Armoly plating)

Electrical

Measuring Element Strain gauge Wheatstone bridge

Element Resistance 350 ohm ±10%

Supply Voltage for 3.33 mV/V output, 6-12VDC (10VDC rec.)
for 4-20mA output, 12-30VDC (24VDC rec.)
for VDC output, 15-30VDC (24VDC rec.)

Zero Balance ±5.0% full-scale output

Internal Resistance Cali. (Factory Adjusted) Produces precise electrical signal which is 80% of full-scale within ±0.25%

Temperature on Strain Gauge Housing

Maximum Temperature 160°F or 70°C

Zero Drift 1.0%/100°F or 2.0%/100°C

Sensitivity Drift 1.0%/100°F or 2.0%/100°C

Temperature on Diaphragm

Max. Temp. (medium) 750°F or 400°C

Zero Shift 25 PSI/100°F or 45 PSI/100°C

Thermocouple (if ordered)

Thermocouple Type Type J

Connector Standard Size Male



Note: All temperature specifications relate to full-scale output or full pressure range output.

Standard Drill Pattern Specifications

D1	D2		D3		D4		A		B		C	
	in	mm	in	mm	in	mm	in	mm	in	mm	in	mm
1/2 - 20 UNF	.313 ± .001	7.95 ± .025	.454 ± .004	11.5 ± .10	.515 min	13 min	.225 min	5.7 min	.17 max	4.3 max	.75	19
M14 x 1.5	.319 ± .001	8.1 ± .025	.478 ± .004	12.1 ± .10	.630 min	16 min	.24 min	6.1 min	.16 max	4 max	.75	19
M18 x 1.5	.398 ± .01	10.1 ± .25	.634 ± .04	16.1 ± 1.0	.79 min	20 min	.24 min	6.1 min	.16 max	4 max	.99	25

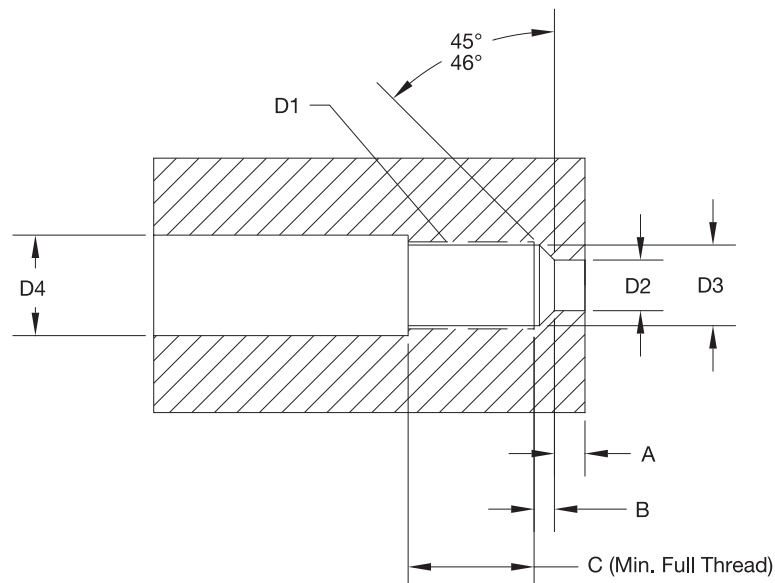

Melt Pressure Transducers

Melt Pressure Transducers Standard Sizes and Ranges

Style	Combined Error	Connector	Pressure Range	Output	Stem Length	Flex Length	Part Number
Rigid Stem	0.5% CE	6 Pin	0-5000	3.33 mV/V	6"	None	PDD00101
Rigid Stem	0.5% CE	6 Pin	0-7500	3.33 mV/V	6"	None	PDD00102
Rigid Stem	0.5% CE	6 Pin	0-10000	3.33 mV/V	6"	None	PDD00103
Rigid Stem	0.5% CE	6 Pin	0-15000	3.33 mV/V	6"	None	PDD00104
Rigid/Flex Armor	0.5% CE	6 Pin	0-5000	3.33 mV/V	6"	18"	PDD00105
Rigid/Flex Armor	0.5% CE	6 Pin	0-7500	3.33 mV/V	6"	18"	PDD00106
Rigid/Flex Armor	0.5% CE	6 Pin	0-10000	3.33 mV/V	6"	18"	PDD00107
Rigid/Flex Armor	0.5% CE	6 Pin	0-15000	3.33 mV/V	6"	18"	PDD00108
Rigid/Flex Armor with T/C	0.5% CE	6 Pin	0-5000	3.33 mV/V	6"	18"	PDD00109
Rigid/Flex Armor with T/C	0.5% CE	6 Pin	0-7500	3.33 mV/V	6"	18"	PDD00110
Rigid/Flex Armor with T/C	0.5% CE	6 Pin	0-10000	3.33 mV/V	6"	18"	PDD00111
Rigid/Flex Armor with T/C	0.5% CE	6 Pin	0-15000	3.33 mV/V	6"	18"	PDD00112

Ordering Code: **PDD** - 1 2 3 4 5 6 7 8 9 10

Style BOX 1

- A** = Rigid Stem
- B** = Flexible Armor Tubing
- C** = Transducer with Type J Thermocouple

Error Tolerance BOX 2

- 1** = 0.5% Combined Error (CE) (*Most Common*)
- 2** = 0.25% CE

Connector BOX 3

- S** = Six-Pin (*Most Common*)
- E** = Eight-Pin
- X** = Special

Pressure Range BOX 4

- A** = 0-500 PSI (0.5% CE only)
- B** = 0-750 PSI (0.5% CE only)
- C** = 0-1000 PSI (0.5% CE only)
- D** = 0-1500 PSI
- E** = 0-3000 PSI
- F** = 0-5000 PSI
- G** = 0-7500 PSI
- H** = 0-10000 PSI
- J** = 0-15000 PSI
- K** = 0-20000 PSI
- L** = 0-35 BAR (0.5% CE only)
- M** = 0-50 BAR (0.5% CE only)
- N** = 0-70 BAR (0.5% CE only)
- P** = 0-100 BAR
- Q** = 0-200 BAR
- R** = 0-350 BAR
- S** = 0-500 BAR
- T** = 0-700 BAR
- U** = 0-1000 BAR
- V** = 0-1400 BAR

Stem Length BOX 5

- 1** = 6 inches (*Most Common*)
- 2** = 12.5 inches
- 3** = 3 inches
- 0** = Other

Flex Length BOX 6

- 00** = None (Style A)
- 18** = 18 Inches* (Styles B & C)
- 24** = 24 Inches* (Styles B & C)
- 30** = 30 Inches* (Styles B & C)

*Other sizes can be made on special request.

Diaphragms BOX 7

- A** = Stainless Steel, 0.0045" (Standard) with GTP+ Coating 750°F/400°C
- B** = 0.0045" Hastelloy® 570°F/300°C
- C** = 0.0045" Chromium Nitride
- D** = 0.008" Chromium Nitride (7500 PSI & up only) 570°F/300°C
- E** = 0.006" Inconel with Titanium Aluminum Nitride 1000°F/538°C
- F** = 0.0045" Titanium Nitride
- G** = 0.008" Titanium Nitride (7500 PSI & up only) 1000°F/538°C
- X** = Other

Output BOX 8

- 0** = Custom
- 1** = 3.33 mV/V (Standard)
- 2** = 4 to 20 ma
- 3** = 0 to 5 Vdc
- 4** = 0 to 10 Vdc
- 5** = 0.5 to 9.5 Vdc

Capillary Fill Material BOX 9

- A** = Mercury (Standard) 750°F/400°C
- B** = Oil-FDA approved 600°F/315°C
- C** = NaK (Sodium Potassium) 1000°F/528°C

Thread BOX 10

- 1** = 1/2-20 (Standard)
- 2** = M18 x 1.5
- X** = Other

ADDITIONAL OPTIONS AVAILABLE...

Exposed Capillary Transducer: for applications requiring a transducer capable of fitting into extremely tight places.

Connectors (*consult Tempco if you require one of these options*)

Gentran GT-76 compatible wiring: strain gauge connector is wired for compatibility with Gentran GT-76 connector.

Barber Coleman TD10 compatible wiring: strain gauge connector is wired for compatibility with Barber Coleman TD10 connector.

Ordering Information

Melt Pressure Transducers are offered with the options listed in the worksheet above. Create an ordering code by filling in the boxes with the appropriate number and/or letter designation for your requirements and a part number will be assigned.

Part Numbers for commonly used Melt Pressure Transducers can be found in table above.

Standard lead time is stock to 3 weeks.

⚠ WARNING: Cancer and Reproductive Harm - www.P65Warnings.ca.gov.

View Product Inventory @ www.tempco.com

Industry ~~CROSS~~ Reference Part Numbers

When using this cross reference please note that the box(□) in the Part Number is for the code for the pressure range. Since the pressure range differs from manufacturer to manufacturer, enter the code letter for the pressure range that best fits your application from **Pressure Range Box 4 on page 12-22**.

Also, though some equipment listed in this cross reference may differ in appearance, the fit and function of the products is equivalent.

NOTE: All transducers listed include 3.3mV/V output, mercury fill and 1/2-20 thread

Description	TEMPCO	Dynisco	ISI	Gefran	Gentran
Basic Melt Pressure Transducer with 0.5% Error, Armoloy Coated Tip and 6-Pin Connector					
6" Rigid stem	PDD-A1S□100A1A1	PT460E□-6	ISI 0100-□T-6	M30-6-M-□-1-4-0	GT-76/6D6□zb
6" Rigid stem with 18" flexible armor tubing	PDD-B1S□118A1A1	PT462E□-6/18	ISI 0101-□T-6/18	M31-6-M-□-1-4-D	GT-76/6D6Z1□
Above transducer with Type J thermocouple	PDD-C1S□118A1A1	TPT463E□-6/18	ISI 0102-□T-6/18	M32-6-M-□-1-4-D	GT-76/6JD6Z1□
Melt Pressure Transducer with 0.5% Error, Armoloy Coated Tip and 8-Pin Connector					
6" Rigid stem	PDD-A1E□100A1A1	n/a	ISI 0160-□T-6	M30-8-M-□-1-4-0	GT-76/6D8□
6" Rigid stem with 18" flexible armor tubing	PDD-B1E□118A1A1	n/a	ISI 0161-□T-6/18	M31-8-M-□-1-4-D	GT-76/6D8Z1□
Above transducer with Type J thermocouple	PDD-C1E□118A1A1	n/a	ISI 0162-□T-6/18	M32-8-M-□-1-4-D	GT-76/6JD8Z1□
Low Error Melt Pressure Transducer with 0.25% Error, Armoloy Coated Tip and 6-Pin Connector					
6" Rigid stem	PDD-A2S□100A1A1	PT420A-□-6	ISI 0110-□T-6	M30-6-H-□-1-4-0	GT-72/6D6□
6" Rigid stem with 18" flexible armor tubing	PDD-B2S□118A1A1	PT422A-□-6/18	ISI 0111-□T-6/18	M31-6-H-□-1-4-D	GT-72/6D6Z1□
Above transducer with Type J thermocouple	PDD-C2S□118A1A1	TPT432A-□-6/18	ISI 0112-□T-6/18	M32-6-H-□-1-4-D	GT-72/6JD6Z1□
Low Error Melt Pressure Transducer with 0.25% Error, Armoloy Coated Tip and 8-Pin Connector					
6" Rigid stem	PDD-A2E□100A1A1	n/a	ISI 0120-□T-6	M30-8-H-□-1-4-0	GT-72/6D8□
6" Rigid stem with 18" flexible armor tubing	PDD-B2E□118A1A1	n/a	ISI 0121-□T-6/18	M31-8-H-□-1-4-D	GT-72/6D8Z1□
Above transducer with Type J thermocouple	PDD-C2E□118A1A1	n/a	ISI 0122-□T-6/18	M32-8-H-□-1-4-D	GT-72/6JD8Z1□
Mechanical Melt Pressure Gauge					
6" Rigid stem	PDG-A1□100A1A1	PG441R-□-6	ISI 0150-□T-6	M50-0-L-□-1-4-0	GT-90/6D□
6" Rigid stem with 18" flexible armor tubing	PDG-A2□130A1A1	PG442R-□-6/30	ISI 0151-□T-6/30	M51-0-L-□-1-4-F	GT-95/6Z3□
Above gauge with Type J thermocouple	PDG-A3□130A1A1	TPG443R-□-6/30	ISI 0152-□T-6/30	M52-0-L-□-1-4-F	GT-95/6JZ3□
Digital Melt Pressure Gauge					
6" Rigid stem	PDG-B1□100A1A1	PG541-□-6	n/a	M60-0-L-□-1-4-0	n/a
6" Rigid stem with 18" flexible armor tubing	PDG-B2□130A1A1	PG552-□-6/30	n/a	M61-0-L-□-1-4-F	n/a
Above gauge with Type J thermocouple	PDG-B3□130A1A1	TPG553-□-6/30	n/a	M62-0-L-□-1-4-F	n/a

Melt Pressure Gauges

Melt Pressure Gauge Styles for Extrusion Processing

Tempco's Melt Pressure Gauges provide highly reliable, maintenance free, local pressure indications for extrusion and other plastics processes. The sensing diaphragm is designed for minimum deflection, maximum durability, and maximum overload capability.

Two models are available with three styles each:

- Mechanical Gauge Model
- Digital Gauge Model with alarm and retransmission

Style 1 A 6" rigid stem unit for standard installations

Style 2 A 30" flexible capillary with stainless steel armored jacket between the gauge housing and the stem to allow greater installation flexibility in tight places or for easier viewing and durability.

Style 3 The third style provides all the features of the 30" flexible capillary model with the addition of a thermocouple (J-type) output for temperature. (Not displayed directly on digital models.)

All models are rugged, totally self contained and allow extrusion processors to benefit from the significantly improved efficiency that goes with pressure monitoring—at about half the cost of strain gauge melt pressure transducers for the mechanical gauge.

Optional diaphragm materials are available for applications that require extra abrasion and/or corrosion resistance. Refer to page 12-19 for available material options.

Mechanical Melt Pressure Gauge



Design Features

- * No Power (or Wiring) Required
- * No Maintenance, No Grease
- * Electron Beam Welded
- * 150% Overload Capability without Damage
- * Greater than 180° Movement for Optimum Readability
- * Stainless Steel Construction
- * 5.44"/138.2mm Diameter Face
- * An Economical Alternative for Many Applications

Specifications

Linearity, Repeatability, Hysteresis: $L \pm 1.0\%$ FSO

Measurement Range: 0-5000 PSI / 0-350 bar to 0-10000 PSI / 0-700 bar

Maximum overpressure: $1.5 \times$ FSO

Measurement principle: Bourdon tube

Maximum housing temperature: . . . 185°F / 85°C

Maximum diaphragm temperature: . 750°F / 400°C

Standard diaphragm material: 15-5 PH Stainless Steel with Armoloy coating

Standard style 3 thermocouple: . . . Type J (isolated junction)

Digital Melt Pressure Gauge



Design Features

- * Better than $\pm 0.50\%$ Accuracy
- * Economically Priced vs. Separate Transducer and Display
- * Electron Beam Welded
- * 200% Overload Capability without Damage
- * 15-5 Stainless Steel Diaphragm with Armoloy coating standard
- * Alarm Provides no/nc, 5A 115/240Vac High Pressure Only Relay
- * 115 VAC standard, 230 VAC Optional
- * 5.44"/138.2mm Diameter Face
- * An Economical Alternative for many Applications
- * Standard 4-20 mA Retransmission

Specifications

Linearity, Repeatability, Hysteresis: $M \pm 0.50\%$ FSO

Measurement Range: See ordering chart

Maximum overpressure: $2 \times$ FSO

Measurement principle: Strain gauge / bridge circuit

Power supply: 115 or 220 VAC (factory set)

Pressure retransmission: 4-20 ma (650Ω max. load)

Maximum housing temperature: . . . 130°F / 55°C

Maximum diaphragm temperature: 750°F / 400°C

Standard diaphragm material: 15-5 PH Stainless Steel with Armoloy coating

below 1000 PSI/70 bar: 17-7 PH SS Ti Ni coated

Standard style 3 thermocouple: . . . Type J (isolated junction)

Alarm: High only, no/nc, 5A 115/240Vac

Melt Pressure Gauges Standard Sizes and Ranges

Mechanical Gauges

Part Number	Style	Pressure Range
PDG00104	6" Rigid Stem	0-5000
PDG00105	6" Rigid Stem	0-10000
PDG00102	6" Rigid/30" Armor Cable	0-5000
PDG00103	6" Rigid/30" Armor Cable	0-10000
PDG00106	6" Rigid/30" Armor Cable with J tc	0-5000
PDG00107	6" Rigid/30" Armor Cable with J tc	0-10000

Digital Readout Gauges

Part Number	Style	Pressure Range
PDG00501	6" Rigid Stem	0-5000
PDG00502	6" Rigid Stem	0-10000
PDG00503	6" Rigid/30" Armor Cable	0-5000
PDG00504	6" Rigid/30" Armor Cable	0-10000
PDG00505	6" Rigid/30" Armor Cable with J tc	0-5000
PDG00506	6" Rigid/30" Armor Cable with J tc	0-10000



Note: All standard flexible armor cable over the pressure sense capillary include a 6" rigid stem and 30" of flexible armor. If a type J thermocouple is specified, a standard size type J plug is provided, similar to the Melt Pressure Transducer shown on page 12-20.

Gauges have standard 1/2-20 UNF drill pattern; see page 12-21.

Ordering Code: **PDG** - ¹ ² ³ ⁴ ⁵

Model and Style BOX 1

- A1** = Mechanical, Rigid Stem
- A2** = Mechanical, Rigid + Flexible Armor Tubing
- A3** = Mechanical gauge with Type J Thermocouple
- B1** = Digital, Rigid Stem
- B2** = Digital, Rigid + Flexible Armor Tubing
- B3** = Digital Gauge with Type J Thermocouple

Stem Length BOX 3

- 1** = 6 inches (*Most Common*)
- 2** = 12.5 inches

Flex Length BOX 4

- 00** = None (*Styles A1 & B1*)
- 30** = 30 Inches*
- *Other sizes can be made on special request.

Pressure Range BOX 2

Mechanical

- | | |
|--------------------|------------------|
| PSI | Bar |
| A = 0-5000 | C = 0-350 |
| B = 0-10000 | D = 0-700 |

Digital - PSI

- | | |
|--------------------|-------------------|
| A = 0-500 | L = 0-35 |
| B = 0-750 | M = 0-50 |
| C = 0-1000 | N = 0-70 |
| D = 0-1500 | P = 0-100 |
| E = 0-3000 | Q = 0-200 |
| F = 0-5000 | R = 0-350 |
| G = 0-7500 | S = 0-500 |
| H = 0-10000 | T = 0-700 |
| J = 0-15000 | U = 0-1000 |

Diaphragms BOX 5

Standard Diaphragm Construction

A = Stainless Steel (.0045") with Armoloy coating (*Most Common*)

Optional Materials and Coatings

- | | |
|------------------------------------|---|
| B = 0.0045" Hastelloy® | E = 0.006" Inconel® with Titanium Aluminum Nitride |
| C = 0.008" Chromium Nickel | F = 0.0045" Titanium Nitride |
| D = 0.0045" Chromium Nickel | G = 0.008" Titanium Nitride |



Note: All digital gauges have one alarm and pressure retransmission.

Ordering Information

Melt Pressure Gauges are offered with the options listed in the worksheet above. Create an ordering code by filling in the boxes with the appropriate number and/or letter designation for your requirements and a part number will be assigned.

Part Numbers for commonly used Melt Pressure gauges can be found in table above.

Standard lead time is stock to 3 weeks.

WARNING: Cancer and Reproductive Harm - www.P65Warnings.ca.gov.

Melt Pressure Display and Alarm Indicators For Extrusion



Design Features

- * 1/8 DIN Size Front Panel
- * 2 Alarms, Programmable Relay Outputs
- * ISO 9001 Certified, CE Approved
- * Economically Priced
- * 4-Digit LED Display for Pressure
- * 3 Keys for Programming
- * Touch-Type Keypad
- * Easy to Calibrate with Sensitivity Auto Ranging
- * Built-In Strain Gauge Bridge Excitation – 10Vdc
- * Filter for Digit Stabilization
- * Coded Access for User Lockout

Model Number: PDA05010

Series **772** Melt Pressure Indicator



Design Features

- * 1/4 DIN Size Front Panel
- * NEMA 4X - IP65 Front Panel Protection
- * 10-point Red LED Bar Graph
- * ISO 9001 Certified, CE Approved
- * 2 Alarms, Programmable Relay Outputs
- * Calibration Output
- * Retransmission – Programmable for 0 - Vdc, 0 - 20 or 4 - 20mA
- * Multiple Programming Levels with Coded Access
- * Peak Value Memory
- * 4-Key Touch-Type Keypad
- * Built-In Strain Gauge Bridge Excitation – 10Vdc
- * Filter for Digit Stabilization
- * RS-232 & RS-485 Communication Available; Consult Factory for More Information

Model Number: PDA05020

Series **882** Melt Pressure Indicator



Design Features

- * 1/4 DIN Size Front Panel
- * Displays Pressure & Temperature Simultaneously on two 4-Digit LED Displays
- * ISO 9001 Certified, CE Approved
- * NEMA 4X - IP65 Front Panel Protection
- * 2 Alarms with Adjustable Setpoint for Temperature or Pressure
- * Calibration Output
- * Retransmission – Programmable for 0 - Vdc, 0 - 20 or 4 - 20mA
- * 10-point Red LED Bar Graph
- * Multiple Programming Levels with Coded Access
- * 4-key Touch-Type Keypad
- * Built-In Strain Gauge Bridge Excitation – 10 Vdc
- * Filter for Digit Stabilization
- * RS-232 & RS-485 Communication Available; Consult Factory for More Information

Model Number: PDA05030

Series **992** Melt Pressure and Temperature Indicator



Melt Pressure Display and Alarm Indicators For Extrusion

SPECIFICATIONS			
Part Number:	772 Series – 1/8 DIN PDA05010	882 Series – 1/4 DIN PDA05020	992 Series – 1/4 DIN PDA05030
Electrical			
Power:	120 Vac \pm 10% or 230 Vac \pm 10% (50/60 Hz) Optional: 11-27 Vac/Vdc for PDA05010 and 20-27 Vac/Vdc for PDA05020/PDA05030		
Operating Temp.:	+32°F to +130°F (0° to 55°C)		
Noise Immunity:	VDE 0843 & IEC 801		
Fascia Seal Rating:	N/A	NEMA 4X – IP65	
Termination:	Screw clamp terminals		
Signal Input			
Type:	350 Ω strain gauge bridge		
Input Sensitivity:	3.3 mV/V	1.5 to 7.5 mV/V	
Accuracy:	\pm 0.2% of full scale \pm 1 digit		
Sensor Excitation:	10 Vdc @ 120 mA		
Calibration:	Will accept transducers with internal shunt calibration values from 40%–100% or external calibration resistors		
Housing	1/8 DIN (48 x 96 x 160 mm)	1/4 DIN (96 x 96 x 160 mm)	
Panel Cutout	1.75 x 3.62 in. (44.5 x 92 mm)	3.62 x 3.62 in. (92 x 92 mm)	
Display			
Type:	4-digit LED display	Two 4-digit LED displays Red: Pressure Green: Temperature	
Ranges:	User programmable for pressure and temperature: –999 to +9999		Pressure: –999 to +9999 Temperature: Standard T/C limits
Units:	PSI, kg/cm ² , BAR, kPa, Pa, MPa	PSI, kg/cm ² , BAR, °F, °C	
Decimal:	Selectable from keyboard		
Setup Prompts:	Displays program steps and error conditions		
Alarms			
Type:	2 SPDT: In the event of a power failure relays go into alarm condition		
Mode:	Absolute, relative with direct or inverse functions can be set via front panel keyboard		
Set Point Range:	0-100% full scale		
Hysteresis:	Configurable per output		
Contact Rating:	5A @ 250 Vac for each alarm output		
Auxiliary Output			
Retransmission:	N/A	0-10 Vdc or 0/4-20mA	
Resolution:	N/A	4000 steps	
Isolation:	N/A	1500V	

Ordering Information:

Order by the part number of the display that meets your requirements.

Standard lead time is stock to 3 weeks.

⚠ **WARNING:** Cancer and Reproductive Harm - www.P65Warnings.ca.gov.

(800) 323-6859 • Email: sales@tempco.com

Melt Pressure Transducer Kits

Melt Pressure Transducer Packages

Melt Pressure Transducer Packages

Special Melt Pressure Transducer Packages have been prepared by Tempco for sale at a discounted price. These packages contain all the components necessary for monitoring your extruder melt pressures.

The package contains:

- One [1] .5% combined error 6" rigid stem MELT PRESSURE TRANSDUCER and a standard Armoloy diaphragm tip in a variety of pressure ranges (see table below)

OR

- One [1] 18" flexible armor cable MELT PRESSURE TRANSDUCER with a 6-pin connector, 6" stem length, and a standard Armoloy diaphragm tip in a variety of pressure ranges (see table below)
- One [1] model 772 MELT PRESSURE INDICATOR
- One [1] 25-foot-long TRANSDUCER CABLE assembly for a 6-pin connector



DISCOUNT PACKAGE		
Part Number		
Transducer Style	Pressure Range (psi)	
Rigid/Flex	Rigid Only	
PDA05101	PDA05201	0-500
PDA05102	PDA05202	0-750
PDA05103	PDA05203	0-1000
PDA05104	PDA05204	0-1500
PDA05105	PDA05205	0-3000
PDA05106	PDA05206	0-5000
PDA05107	PDA05207	0-7500
PDA05108	PDA05208	0-10000
PDA05109	PDA05209	0-15000
PDA05110	PDA05210	0-20000

Ordering Information

Order by the part number of the product that meets your requirements. **Standard lead time is stock to 3 weeks.**

ACCESSORIES – Connectors and Cable Assemblies

6-and 8-Pin Transducer Cables

These connectors and cable assemblies are designed to be compatible with the 6-pin and 8-pin connectors used on Tempco's line of melt pressure transducers.

The cable assemblies come with a female connector on one end to connect to the transducer, and the other end has 6 or 8 braided wire leads to connect to input and output sources, displays or controllers.

The transducer mating connector offered is the female mating connector with no cable or wiring attached.

Thermocouple Cables

The cable assemblies and connector are designed to be compatible with the connectors used on Tempco's line of melt pressure transducers with Type J thermocouples.

The cable assemblies come with a Type J female connector on one end to mate with the Transducer/Thermocouple assembly and leads on the other end.

The mating connector offered is a Type J two-pin female connector designed to mate with the male thermocouple connector on the Transducer/Thermocouple assembly.

TRANSDUCER MATING CONNECTORS (hardware only)	
6-Pin Part Number	8-Pin Part Number
PDA00215	PDA00213

THERMOCOUPLE MATING CONNECTOR Standard Size, Female Type J
Part Number
TCA-102-101

THERMOCOUPLE CABLE ASSEMBLIES	
Size	Part Number
25 feet	ECA00057
50 feet	ECA00058
75 feet	ECA00059
100 feet	ECA00060

TRANSDUCER CABLE ASSEMBLIES		
Size	6-Pin Part Number	8-Pin Part Number
10 feet	PDA00216	—
25 feet	PDA00201	PDA00205
50 feet	PDA00202	PDA00206
75 feet	PDA00203	PDA00207
100 feet	PDA00204	PDA00208

GENERAL ACCESSORIES	
Description	Part Number
3-Piece Cleaning Tool Kit (1/2-20 thread)	PDA00251
Transducer Mount Drill Kit	PDA00253
Transducer Pressure Simulator—6-Pin	PDA00254
Transducer Pressure Simulator—8-Pin	PDA00255
Mounting Bracket	PDA00256

Rupture Disks for Plastic Extrusion Protection

Custom Pressure Relief Solutions for your Extrusion Equipment

Construction Characteristics

Tempco's Extruder Rupture Disks are pressure relief devices designed for overpressure protection of plastic extruders. A rupture disk is soldered or welded to the end of a threaded hollow bolt to fit flush in the extruder barrel. This prevents plastic buildup and hardening that might render the rupture disk ineffective. Tempco carries a number of sizes to fit standard thermocouple wells to serve as replacements for expended units.

Design Features

- * 303 Stainless Steel Body, Inconel® Rupture Disk
- * 3/16" Burst Diameter
- * Rupture Pressure Tolerance $\pm 5\%$
- * NPT Fittings for Discharge Available
- * Designed to Fit Common Thermocouple or Transducer Drill Pattern
- * Select a Pressure Rating Exceeding your Normal Operating Pressure by 1.4 Times without Exceeding the Manufacturer's High Pressure Specifications

1-13/16" Long 1/2-20 UNF Threaded with a Screwdriver Slot at 300°F (149°C) to 750°F (399°C)



Pressure (PSI)	Part Number
3500	ERD01001
5000	ERD01002
5500	ERD01003
6000	ERD01004
6500	ERD01005
7000	ERD01006

Pressure (PSI)	Part Number
7500	ERD01007
8000	ERD01008
8500	ERD01009
9000	ERD01010
9500	ERD01011
10000	ERD01012

6" Overall Length 1/2-20 UNF Threaded at 300°F (149°C) to 750°F (399°C)



With Wrench Flat



With Hex Head Adapter



With Hex Head and
1/4-18 NPT Male Fitting

Pressure (PSI)	Part Number		
	Wrench Flat	Hex Head	1/4 NPT
2500	ERD02001	ERD03001	ERD04001
3000	ERD02002	ERD03002	ERD04002
3500	ERD02003	ERD03003	ERD04003
4000	ERD02004	ERD03004	ERD04004
5000	ERD02005	ERD03005	ERD04005
5500	ERD02006	ERD03006	ERD04006
7000	ERD02007	ERD03007	ERD04007
7500	ERD02008	ERD03008	ERD04008
8000	ERD02009	ERD03009	ERD04009
8500	ERD02010	ERD03010	ERD04010
9000	ERD02011	ERD03011	ERD04011
9500	ERD02012	ERD03012	ERD04012
10000	ERD02013	ERD03013	ERD04013

Installation Data

Rupture Disk Critical Mounting Dimensions

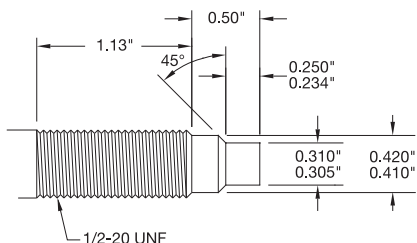

Standard Drill Pattern

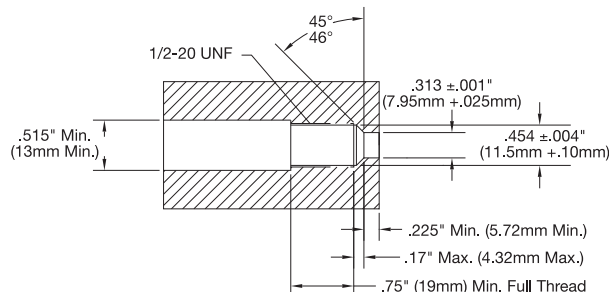

Ordering Information

Select the Rupture Disk style, pressure and temperature rating that matches your application requirements. Alternate pressure, temperature and physical configurations are possible; consult TEMPCO with your requirements. **Standard lead time is stock to 4 weeks.**

⚠ WARNING: Cancer and Reproductive Harm - www.P65Warnings.ca.gov.

(800) 323-6859 • Email: sales@tempco.com

Beam-A-Temp™ Wide Range Mini-Infrared Thermometer

Measures non-contact surface temperature up to 1200°F/650°C



Temperature range from
-58 to 1200°F (-50 to 650°C)

Design Features

- * 12:1 distance to target ratio.
- * Compact thermometer measures temperature from -58 to 1200°F (-50 to 650°C) with 0.1° resolution up to 999.9°.
- * Adjustable High/Low setpoints with audible alarm alerts user when temperature exceeds the programmed setpoints.
- * Adjustable emissivity for better accuracy on different surfaces.
- * Built-in laser pointing identifies target area.
- * Backlighting illuminates display for taking readings in low light areas.
- * Data Hold and Min/Max.
- * Over-range indicator.
- * Complete with 9V battery and pouch case.

Specifications

Temperature Range: -58 to 1200°F (-50 to 650°C)
Basic Accuracy: ±(1% of reading + 2°F/1°C)
Maximum Resolution: 0.1°F/°C; 1°F/°C
Emissivity: 0.10 to 1.00 adjustable
Repeatability: ±0.5% or ±1.8°F/°C
Field of View: 12:1
Dimensions: 3.2 × 1.6 × 6.3" (82 × 42 × 160 mm)
Weight: 6.4 oz. (180g)

Agency Approval: 

Applications

- ➔ Measure the surface temperature of objects difficult to reach or unsafe to touch.
- ➔ Scan for hot spots on motors, electrical panels, electrical circuits and other equipment.
- ➔ Used extensively in processes where glass, iron and steel, non-ferrous materials, and minerals must be monitored.

Ordering Information

Part Number **REB30012** Wide Range Mini-IR Thermometer
Part Number **REB32012** Wide Range Mini-IR Thermometer
with NIST Certificate

Standard lead time is stock to 3 weeks.

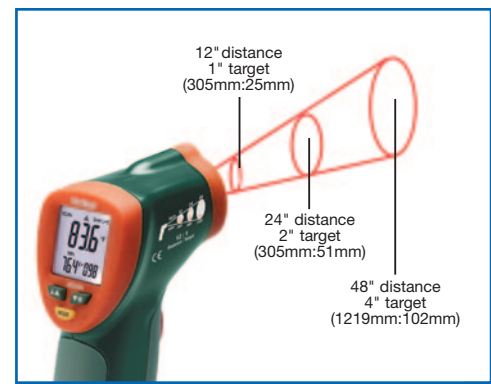

12:1 distance to target ratio

 **WARNING:** Cancer and Reproductive Harm - www.P65Warnings.ca.gov.

Beam-A-Temp™ Wide Range Infrared Thermometer with Type K input

Measures both non-contact and contact temperature with type K thermocouple input



Memory stores up to 20 readings!

REB30020 with Type K temperature probe (included range -4 to 482°F/-20 to 250°C) for contact temperature measurements. Compatible with other Type K thermometers with sub-miniature connector for higher temperature measurements up to 2498°F (1370°C).

Design Features

- * Wide temperature range for IR temperature and type K thermocouple instruments.
- * Automatic emissivity adjustment (for temperatures 212°F or higher).
- * Memory stores up to 20 readings.
- * Large LCD display with bright backlight for easy-to-read measurements and programming parameters.
- * Laser pointer provides better aim and accuracy.
- * Auto-hold activates when the measurement trigger is released.
- * Adjustable high/low alarm alerts user visually and audibly when temperature exceeds programmed limits.
- * MAX/MIN/AVG/DIF features display highest, lowest, average, and MAX minus MIN values.
- * Data Hold, Auto Power Off, and low battery indication.
- * Switches built into handle allow for °C/°F display selection, auto power off defeat, and alarm on/off control.
- * Complete with 9V battery, type K thermocouple sensor (-4 to 482°F / -20 to 250°C), and carrying case.
- * 1-year warranty.

Specifications

Display Counts: . . 4000 count backlit display
Range: Infrared: -58 to 1472°F (-50 to 800°C)
 Type K: -58 to 2498°F (-50 to 1370°C)
Basic Accuracy: . . Infrared: ±2% of reading or ±4°F/2°C
 Type K: (±1.5% of reading +2°F/1°C)

Maximum Resolution: 0.1°F/°C
Emissivity: Adjustable 0.10 to 1.00
Field of View: 13:1 distance to target ratio
Dimensions: 3.2 × 1.6 × 6.3" (82 × 42 × 160 mm)
Weight: 6.4 oz. (180g)

Agency Approval:

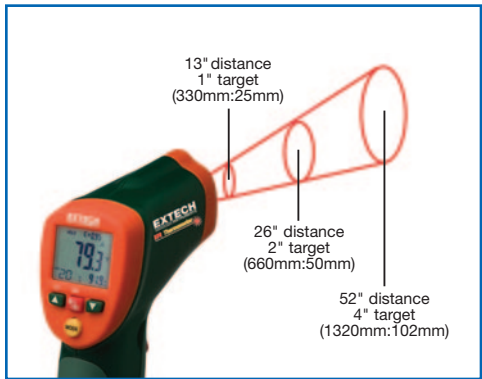

13:1 distance to target ratio

WARNING: Cancer and Reproductive Harm - www.P65Warnings.ca.gov.

Ordering Information

Part Number **REB30020** Wide Range IR Thermometer + Type K
 Part Number **REB32020** Wide Range IR Thermometer with NIST Certificate

Standard lead time is stock to 3 weeks.

Beam-A-Temp™ High Temperature Infrared Thermometer

Measures surface temperature up to 1400°F/760°C

Temperature range from
-58 to 1400°F (-50 to 760°C)!



Design Features

- * Wide temperature range from -58 to 1400°F (-50 to 760°C).
- * High 16:1 distance to target ratio measures smaller surface areas at greater distances.
- * Adjustable emissivity from 0.1 to 1.00 increases measurement accuracy for different surfaces.
- * Adjustable High/Low setpoints alarm with audible alarm alerts user when temperature exceeds the programmed setpoints.
- * Data Hold, MAX/MIN/AVG plus differential between MAX - MIN.
- * Built-in laser identifies target area.
- * Backlit LCD display.
- * High resolution of 0.1° up to 199.9°.
- * Auto power off.
- * Complete with 9V battery and hard carrying case.
- * 3-year warranty.

Specifications

Range: -58 to 1400°F (-50 to 760°C)
Basic Accuracy: ±2% of reading or 4°F/2°C <932°F (500°C); ±(2.5% of reading +5°) >932°F (500°C)
Maximum Resolution: 0.1°F/°C
Emissivity: 0.1 to 1.00 Adjustable
Field of View (Distance to Target): . . 16:1
Dimensions: 3.9 × 2.2 × 9" (100 × 56 × 230 mm)
Weight: 10.2 oz. (290g)

Agency Approval: 

Applications

- Measure the surface temperature of objects difficult to reach or unsafe to touch.
- Scan for hot spots on motors, electrical panels, electrical circuits and other equipment.
- Used extensively in processes where glass, iron and steel, non-ferrous materials, and minerals must be monitored.

Ordering Information

Part Number **REB30030** High Temperature IR Thermometer
Part Number **REB32030** High Temperature IR Thermometer with NIST Certificate

Standard lead time is stock to 3 weeks.

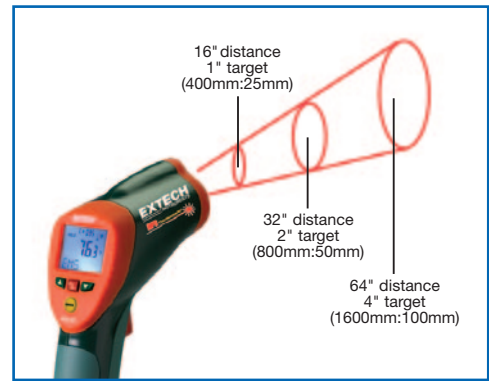

16:1 distance to target ratio

 **WARNING:** Cancer and Reproductive Harm - www.P65Warnings.ca.gov.

Beam-A-Temp™ Portable Infrared Thermometer

Measures up to 1832°F/1000°C with 50:1 distance to target ratio

*Temperature range from
-58 to 1832°F (-50 to 1000°C)!*



Design Features

- * Built-in laser identifies target area.
- * High and low alarms.
- * Adjustable emissivity increases measurement accuracy for different surfaces.
- * Adjustable High/Low setpoints alarm with audible alarm alerts user when temperature exceeds the programmed setpoints.
- * MAX/MIN/AVG plus differential between MAX – MIN.
- * Backlighting illuminates display for taking measurements at night or in areas with low background light levels.
- * High resolution of 0.1° up to 199.9°.
- * Automatic Data Hold when trigger released.
- * Auto power off.
- * Wide temperature range from -58 to 1832°F (-50 to 1000°C).
- * High 50:1 distance to target ratio measures smaller surface areas at greater distances.
- * Complete with 9V battery and carrying case.
- * 3-year warranty.

Specifications

Range:	-58 to 1832°F (-50 to 1000°C)
Basic Accuracy:	±2% of reading or +4°F/2°C
Maximum Resolution:	0.1°F/°C
Emissivity:	Adjustable
Field of View (Distance to Target):	..	50:1
Dimensions:	3.9 × 2.2 × 9" (100 × 56 × 230 mm)
Weight:	10.2 oz. (290g)

Agency Approval:

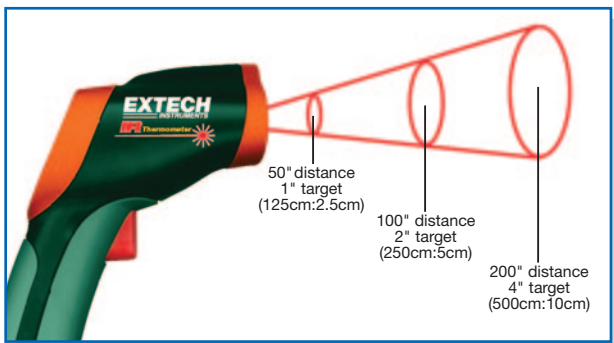

50:1 distance to target ratio

Ordering Information

Part Number **REB30040** Portable IR Thermometer
Part Number **REB32040** Portable IR Thermometer
with NIST Certificate

Standard lead time is stock to 3 weeks.

WARNING: Cancer and Reproductive Harm - www.P65Warnings.ca.gov.

(800) 323-6859 • Email: sales@tempco.com

Non-contact Infrared Temperature Measurement System — NCIT-LC Plus Series

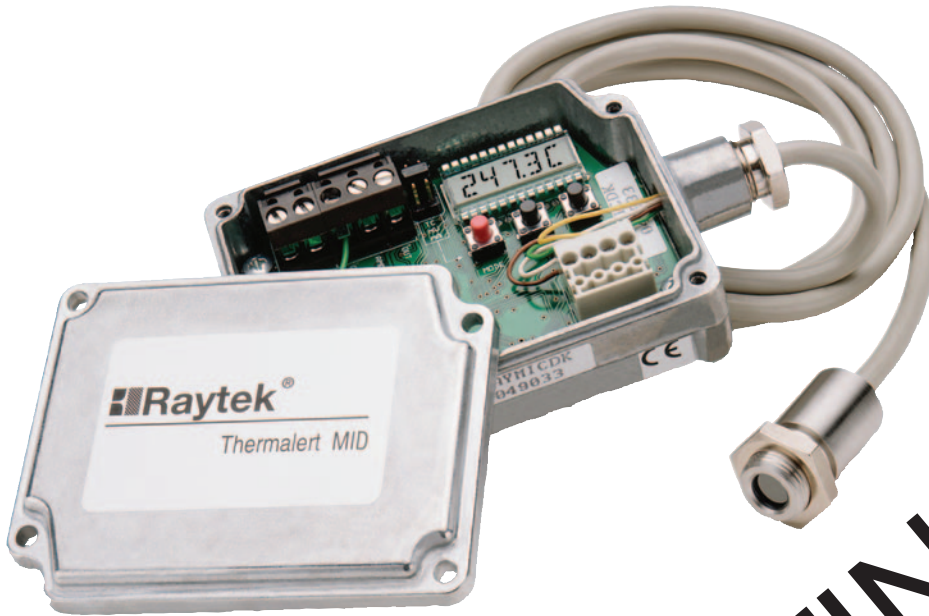

Proven Technology

PRECISION INFRARED TEMPERATURE MEASUREMENT has been around for years to increase productivity, reduce costs and improve product quality. Microfabrication techniques have allowed us to reduce the size and cost of our sensors, bringing the benefits of this technology to a new group of users.

Many of the NCIT-LC Plus's features are typically only available on larger and more expensive units and offer more flexibility through remote monitoring and control of all sensor variables.

World's Smallest IR Sensor

The NCIT-LC Plus is a versatile two-piece system with a miniature sensing head and separate electronics. The sensor is small enough to be installed just about anywhere, yet it performs as well as much larger systems. The sensor is housed in rugged stainless steel to ensure long-term performance, even in harsh environments with ambient temperatures up to 85°C (185°F). And the NCIT-LC Plus's response time is as fast or faster than many high-end systems.

Rugged, Reliable, Practical Features

The NCIT-LC Plus's electronics include: Emissivity and selectable Peak Hold, Valley Hold, and Averaging, all of which (including output type) are programmable on the 5-digit/3-button LCD user interface.

Accessories, including an air purge jacket, air cooling jacket, and mounting adapters, ensure accuracy in applications ranging from plastics manufacturing to food processing.

Design Features

- * -40°F to 1132°F (-40° to 600°C)
- * Compact and Rugged
- * 5-digit backlit LCD User Interface
- * Designed for Online Monitoring and Control
- * Ultra-Fast Response Time - 150 ms
- * Stainless Steel Sensing Head
- * 10:1 and 22:1 Optics
- * 0/4 - 20 mA or 0 - 5Vdc, J or K thermocouple outputs
- * Choice of 3 ft. or 10 ft. cable
- * Mounting Hardware Included
- * 12-24VDC Powered

Common Industrial Applications

- Plastics
 - Paper and Pulp Converting
 - Chemicals
 - Food Processing
 - Pharmaceutical
 - Electronics
 - Construction
 - Industrial Maintenance

Optional Communications for PC Interfacing

Even more features are available with optional RS-232 or RS-485 communications and the new DataTemp® Multidrop Software. These features include remote control and monitoring of all sensor variables, a 5V alarm signal triggered by a target temperature or head ambient temperature. Also included is an 8-position "recipe" table that can be easily interfaced to an external control system, an external reset signal input for signal processing, and even external inputs for analog emissivity adjustment or reflected energy compensation.

Lower cost sensors are available with fixed emissivity; consult Tempco for further details.

Non-contact Infrared Temperature Measurement System — NCIT-LC Plus Series

Measurement Specifications

Temperature Range:	-40 to 1112°F (-40 to 600°C)
Spectral Response:	8 to 14 μm
Optical Resolution:	10:1
System Accuracy:	±1% or ±1°C, whichever is greater
Repeatability:	±0.5% or ±0.5°C, whichever is greater
Response Time:	150 ms, 95% of final reading
Emissivity:	Digitally adjustable, 0.1 to 1.10 by increments of 0.001 steps
Signal Processing:	Peak hold, Valley hold, Variable averaging filter, adjustable up to 998 sec.



Note:
The basic system includes the sensing head and nut, die cast housing with pre-mounted electronic board, 3m (10 ft.) cable, and operator manual.

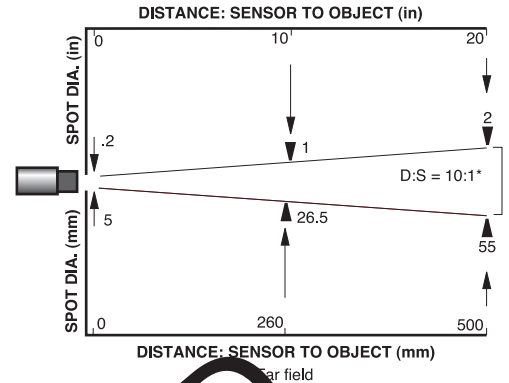

Electrical Specifications

Programmable Outputs: 0/4 - 20 mA, 0 - 5 Vdc (scalable)
J or K thermocouple
10 mV / °C head ambient signal

Power (user to supply unit): 12 - 24 Vdc @ 100 mA
Max. Loop Impedance: 500Ω with 24 Vdc power supply

Sensor Specifications

Environmental Rating: NEMA 4 (IP65)
Max. Ambient Temperature: Sensing head: 32° to 185°F (0 to 85°C)
With air cooling up to 392°F (200°C)
Elect. housing: 32° to 149°F (0 to 65°C)
Relative Humidity: 10 to 95%, non-condensing
Weight: Sensing head: 50g w/cable, stainless steel
Electronics housing: 270g, Zinc, die-cast

Model Numbers

Part Number	Optical Resolution	Cable Length	Range Type
REN00150	10 : 1	10 ft. / 3 m	LT - low temp
REN00155	10 : 1	3 ft. / 1 m	LT - low temp
REN00170	22 : 1	10 ft. / 3 m	LT - low temp
REN00175	22 : 1	3 ft. / 1 m	LT - low temp
with RS485 data interface			
REN00151	10 : 1	10 ft. / 3 m	LT - low temp
REN00156	10 : 1	3 ft. / 1 m	LT - low temp
REN00171	22 : 1	10 ft. / 3 m	LT - low temp
REN00176	22 : 1	3 ft. / 1 m	LT - low temp

Communication Accessory Connection Kits are required for setup and monitoring of extended multi-drop features. One kit can service multiple sensors. These kits contain DataTemp® Multi-Drop software and connectors to provide for simple setup of analog/digital inputs and outputs of the optional RS232 or RS485 interface via a PC.

- REN00306** — RS485 2-wire connection kit provides for setup and monitoring via DataTemp® Multi-Drop software and a RS485/RS232 converter provided with 110Vac power supply
- REN00307** — RS232 connection kit provides for setup and monitoring via DataTemp® Multi-Drop software and a 3-wire RS232 connection
- REN00209** — Power supply: 12 Vdc at 200 mA, 120 Vac input

Sensor Head

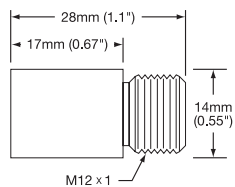

Electronics Enclosure

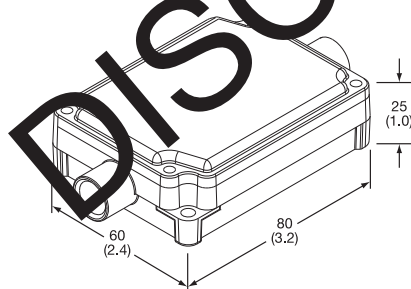

Optional: Electronics enclosure with view port window in cover
Part Number: REN00308

$$\text{Dim.} = \frac{\text{mm}}{(\text{in})}$$

Adjustable Mounting Bracket — REN00303

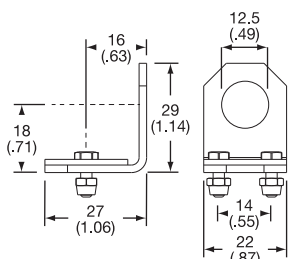

Optical Lens Air Purging Jacket — REN00302

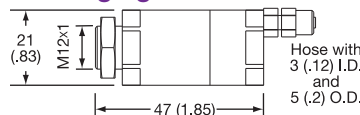

Air Cooling System — REN00301

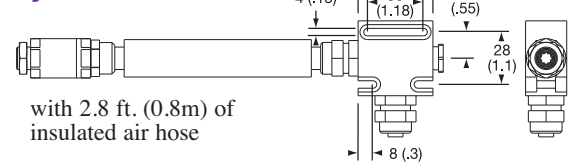

Ordering Information

Choose the **NCIT-LC Plus**, accessories, and/or options desired, and order by the associated part number.

Standard lead time is stock to 3 weeks.

Non-contact Infrared Temperature Measurement System — NCIT-LC Advanced



Design Features

- * Rugged IP65 rated sensing heads survive ambient temperatures to 248°F (120°C) without cooling
- * Precision high resolution optics, up to 22:1
- * Fast response times of < 20 ms
- * Miniature sensing head fits where other sensors can't
- * Intuitive user interface with high resolution LCD display
- * Automatic sensing head detection — plug and play
- * User configurable analog outputs (0/4-20mA, 0-5/10V, type J, K, R or S t/c)
- * Isolated solid state alarm relay output
- * Adjustable Emissivity, Peak Hold, Valley Hold and Averaging functions
- * Standard USB 2.0 digital interface for remote setup

The NCIT-LC Advanced is a powerful **two-piece** infrared temperature measurement system with miniature sensing head and separate communications electronics. The sensor is small enough to be installed just about anywhere, yet it outperforms much larger systems.

Available in a rugged cast metal electronics enclosure, the **LC-Advanced** offers a host of advanced signal processing features you won't normally find in sensors costing much more.

Designed for an **endless range of applications**, the **LC-Advanced** features a variety of sensing head options. Low temperature sensors with a measurement range of -40°F to 1832°F (-40°C to 1000°C), fast response (<20 mSec) sensors, and 5 μm spectral response sensors, provide an impressive array of solutions for your process needs.

The **rugged stainless steel sensing head** ensures reliable long term performance in the harshest industrial environments. Although the LC-Advanced sensor is small in size, it has all the performance you need with 1% accuracy, and a **choice of high resolution optics up to 22:1**.

Standard features include adjustable Emissivity, Peak Hold, Valley Hold, and Averaging functions. All sensor parameters are easily adjustable on the built-in user interface keypad, or remotely with the Windows® 7 compatible DataTemp software via the **built-in USB interface**.

Advanced features further extend the power of the **LC-Advanced** and include user configurable alarm output, digital "recipe" table inputs that can be easily interfaced to an external control system, an external reset input for signal processing, and external inputs for analog emissivity adjustment or reflected energy compensation.

Optional RS485, Modbus® or Profibus® network interfaces simplify integration with a factory or machine control system.

The **NCIT-LC Advanced** — a new level of innovation and performance in non-contact temperature measurement!

Specifications

Spectral Response:LT (Low Temp.)— 8 to 14 microns
.....G5 (glass)— 5 microns

Optical Resolution: LTS — 2:1, 10:1, 22:1
LTF — 10:1
G5 — 22:1

Temperature Range:
LTS (2:1, 10:1) -40° to 1112°F (-40° to 600°C)
LTF (LTS 22:1) 32° to 1832°F (0° to 1000°C)
G5S 482° to 3002°F (250° to 1650°C)

System Accuracy: ±1% of reading or ±1°C, whichever is greater

Thermocouple Output Accuracy: <1°F (0.5°C)
±1% of reading or ±2.5°C, whichever is greater

System Repeatability: ±0.5% of reading or ±0.5°C (1°F), whichever is greater

Temperature Resolution: LT 0.1°C or 0.2°F

System Response Time: LTS 130ms (90%)
LTF 20ms (90%)
G5 55ms (90%)

Emissivity: 0.100 to 1.100 digitally adjustable increments of .001

Transmission: 0.1 to 1.000 digitally adjustable increments of .001

Signal Processing: Peak hold, valley hold, variable averaging filter, adjustable up to 998 seconds

Non-contact Infrared Temperature Measurement System — NCIT-LC Advanced

Sensor Head Specifications

Environmental Rating: NEMA 4 (IP65)

Head Ambient Temperature Range: 14° to 248°F (-10° to 120°C)

With air cooling up to 392°F (200°C)

Cable Length: 3.3 ft (1m) standard, optional: 9.9 ft (3m), 26 ft (8m), 50 ft. (15m)

Storage Temperature: -4° to 185°F (20° to 85°C)

Relative Humidity: 10 to 90%, non-condensing

Construction: Stainless Steel

Weight with 1 m cable: 1.75 oz. (50g)

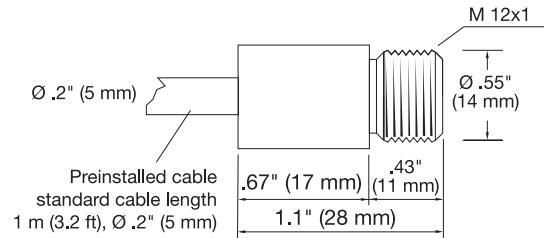

Available Sensor Heads

Part Number	Optics	Sensing Temperature Range	Response Time	Maximum Ambient Temperature	Type	Cable Length	Comments
REN30001	2:1	-40° to 1112°F (-40° to 600°C)	130ms	248°F/120°C	LTS	3.3 ft./1m	General Purpose
REN30002	10:1	-40° to 1112°F (-40° to 600°C)	130ms	248°F/120°C	LTS	3.3 ft./1m	General Purpose
REN30003	22:1	32° to 1832°F (0° to 1000°C)	130ms	248°F/120°C	LTS	3.3 ft./1m	General Purpose
REN30004	10:1	32° to 1832°F (0° to 1000°C)	20ms	248°F/120°C	LTF	3.3 ft./1m	Fast Response
REN30005	10:1	482° to 3002°F (250° to 1650°C)	130ms	248°F/120°C	G5	3.3 ft./1m	5μm sensing for glass applications

The NCIT-LC Advanced Infrared sensor heads can be supplied with the following optional cable lengths:

- 10 ft. / 3m cable
- 26 ft. / 8m cable
- 49 ft. / 15m cable
- 98 ft. / 30m cable

Calibration Certificate with NIST/DKD traceability can be provided. Specify when ordering.

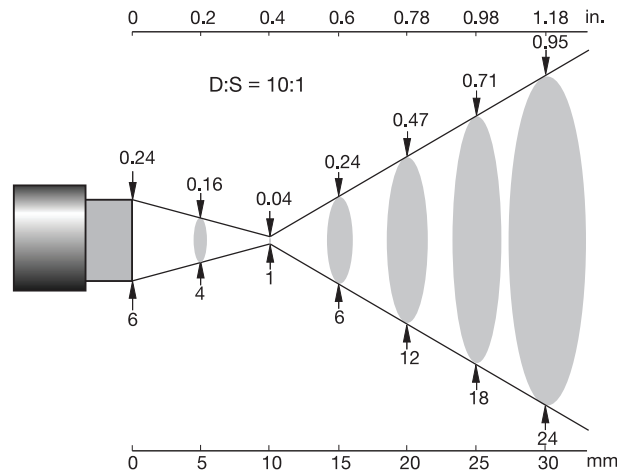

10:1 optics with close focus accessory

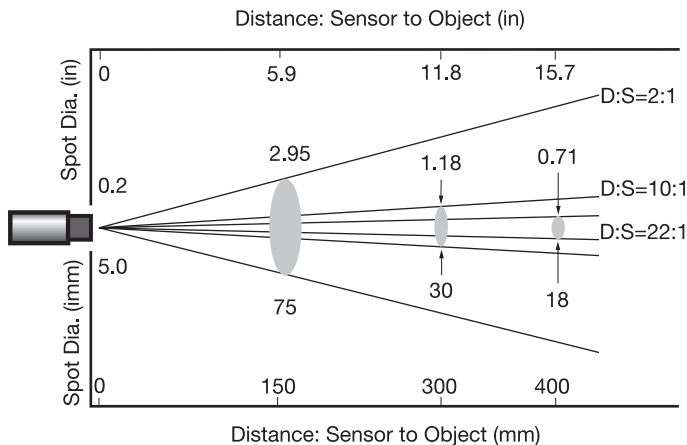

2:1, 10:1 and 22:1 optics

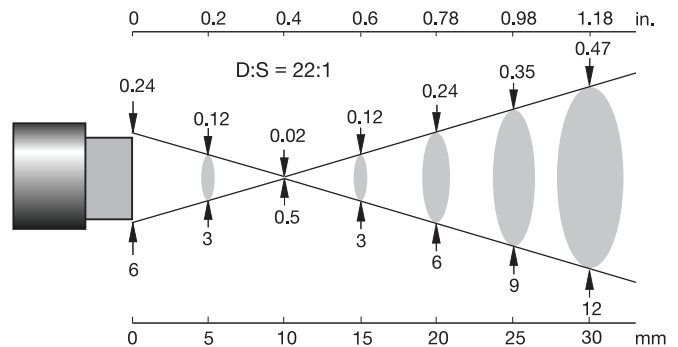

22:1 optics with close focus accessory

CONTINUED 

Non-contact Temperature Measurement

Non-contact Infrared Temperature Measurement System — NCIT-LC Advanced

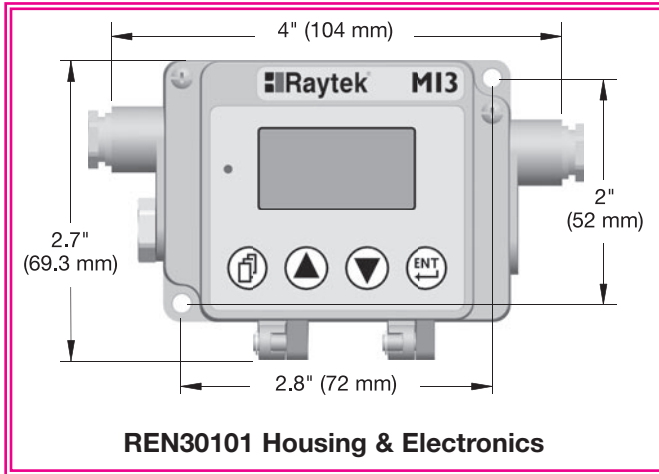

REN30101 NCIT-LC Advanced Electronics and Enclosure Specifications

- Digital Interface:** USB 2.0
(RS485, Modbus® or Profibus® optional)
- Outputs:** Scalable 4-20mA, 0-20mA,
0-10V, 0-5V, J, K, R or S thermocouple
- Inputs:** Digital inputs for emissivity control, ambient background temperature compensation, trigger/hold input
- Alarm Relay:** 48 VAC, 300 mA optically isolated solid state relay
- Output Impedance (TC output):** 20 ohms
- Minimum Load Impedance:** (mV output): 10K ohms
- Maximum Loop Impedance:** (mV output): 500 ohms
- Power Draw:** 4W max
- Power Supply:** 8-32VDC
- Housing Construction:** Zinc, die cast
- Environmental Rating:** NEMA 4 (IP65)
- Electronics Housing, Max. Temp.:** 14° to 150°F (-10° to 65°C)
- Storage Temperature:** -4° to 185°F (-20 to 85°C)
- Relative Humidity:** 10 to 95%, non-condensing
- Electronics Weight:** 9.5 oz. (270g)

The **REN30101** NCIT-LC Advanced Electronics and Enclosure can also be ordered with the infrared sensor head pre-installed.

Specify which Sensor Head meets your requirements when ordering.

Ordering Information

Select the part numbers of the NCIT-LC Advanced Sensor Head, Electronics/Enclosure and Accessories that meet your requirements.

Standard lead time is stock to 4 weeks.

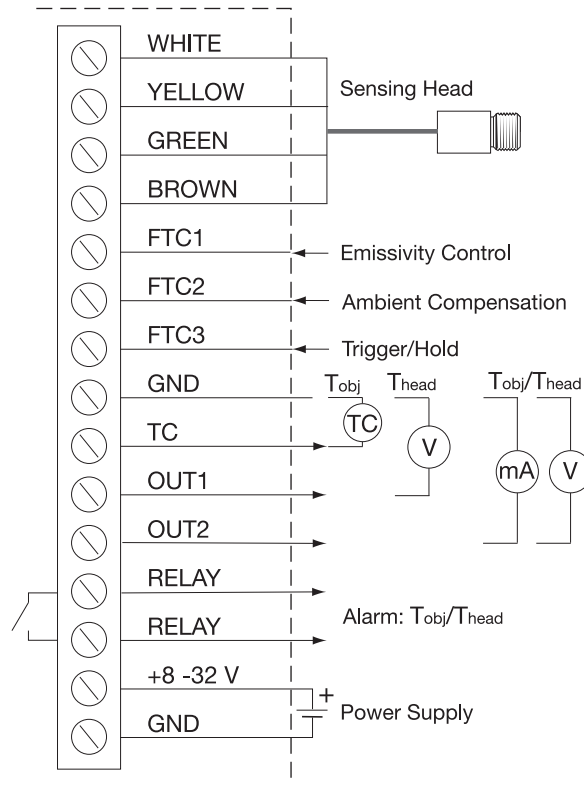

REN30101 NCIT-LC Advanced Electronics Enclosure Terminal Wiring

Accessories

Part Number	Description
REN00309	Close focus lens accessory. 10 mm focus distance.
REN00209	Power supply: 12 Vdc at 200 mA, 120 Vac input
REN00301	Air cooling and purging system with 2.8 ft./8m of hose Maximum ambient temperature: 392°F/200°C
REN00302	Air purge jacket, no cooling
REN00303	Sensing head, adjustable mounting bracket
REN00305	Sensing head, fixed mounting bracket

⚠ WARNING: Cancer and Reproductive Harm - www.P65Warnings.ca.gov.

Non-contact Infrared Temperature Measurement System — NCIT-LLC Series



The NCIT - LLC model provides the advantages of infrared temperature measurement in a compact, low cost, integrated sensor. Designed for easy integration with a standard 4-wire system, the CI sensor can easily replace traditional contact probes with a type J or K thermocouple output, or with a 0-5 volt dc output if your application is susceptible to noise or requires a longer cable run.

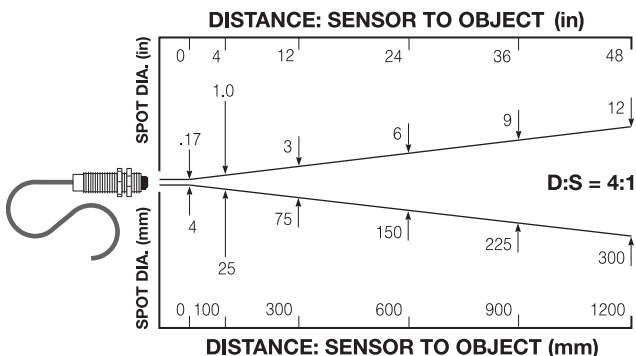
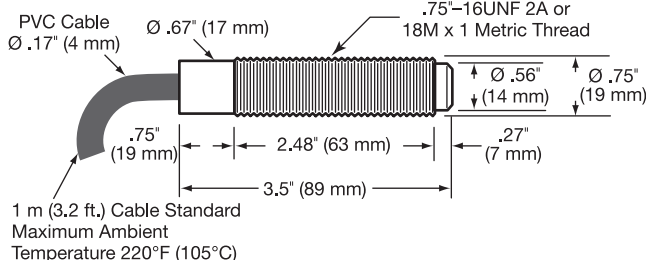

Ordering Code:

REN2 - 1 2 3 4 & 5

Basic assembly includes: sensor with 3/4-16 UNF thread, preinstalled 3.3 ft./1 m cable and two mounting nuts.

Overall Range BOX 1

1 = 32° to 662°F (0° to 350°C)
2 = 86° to 932°F (30° to 500°C)

Output BOX 2

J = Type J thermocouple
K = Type K thermocouple
V = 10mV/°C

Cable Length and Type BOX 3

A = 3.3 ft./1m cable - 220°F/105°C
B = 10 ft./3m cable - 220°F/105°C
C = 50 ft./15m cable - 220°F/105°C
Specify D, E or F if ordering coolable housing
D = 3.3 ft./1m cable - 500°F/260°C
E = 10 ft./3m cable - 500°F/260°C
F = 50 ft./15m cable - 500°F/260°C

Options (Select 2) BOX 4 & 5

C = Coolable housing with air purge
M = 18M x 1 metric thread instead of 3/4-16 UNF
N = None

Ordering Information

Create an ordering code by filling in the boxes per your requirements and a part number will be assigned.

Standard lead time is stock to 4 weeks.

WARNING: Cancer and Reproductive Harm - www.P65Warnings.ca.gov.

Design Features

- * Type J or K thermocouple, or 0-5 VDC output
- * Two models cover temperature ranges from 32° to 932°F (0° to 932°F)
- * NEMA 4 (IP 65) stainless steel housing
- * 4:1 optics at 90% energy
- * 350 ms response time to 90% energy
- * Powered by 12-24 VDC at 20 mA
- * Accessories for cooling and air purging

Measurement Specifications

Overall Temperature Range: 32° to 662°F (0° to 350°C)

Accuracy: 32° - 240°F (0° - 115°C): ±6°F (±3°C)

241° - 440°F (116° - 225°C): ±5%

441° - 662°F (116° - 225°C): >±5%

Overall Temperature Range: 86° to 932°F (30° to 500°C)

Accuracy: 86° - 211°F (30° - 99°C): ±10°F (±6°C)

212° - 932°F (100° - 500°C): ±2% or ±6°F (3°C)

Spectral Response: 7 to 18 microns

Repeatability: 1% of reading or ±2°F (1°C)

Temperature Resolution: <1°F (0.5°C)

Response Time (95%): 350 ms

Emissivity: Fixed at 0.95

Electrical Specifications

Outputs: Select Type J or K thermocouple or 10 mV / °C

Output Impedance: 50 ohms

Min. Load Impedance: 50K ohms

Power Supply: 12 - 24 Vdc @ 20 mA

Standard Cable Length: 3.2 ft. (1 m)

Sensor Specifications

Environmental Rating: NEMA 4 (IP65)

Ambient Temperature Range: 32° to 160°F (0 to 70°C)

With air cooling 32° to 200°F (0 to 90°C)

With water cooling 32° to 500°F (0 to 260°C)

Thread: 3/4-16 UNF, optional 18M x 1

Storage Temperature: -22° to 185°F (-30 to 85°C)

Relative Humidity: 10 to 90%, non-condensing

Weight: 4.5 oz. (130g)

Accessories

Part Number	Description
REN25001	Fixed Mounting Bracket
REN25002	Adjustable Mounting Bracket
REN25003	Lens Air Purge Collar
REN25004	Right Angle Mirror

Non-contact Infrared Temperature Measurement System — NCIT Plus Series



If temperature is a factor in your quality and manufacturing yield, then put this technology to work for you.

Design Features

- * 0° to 1000°F (-18 to 538°C)
- * Compact 1/8 DIN digital monitor with large 4-digit display
- * User-defined thermocouple or 4-20 mA output
- * Universal 110-220 VAC power input
- * Adjustable emissivity at ambient parameters
- * Adjustable dual setpoints and deadband alarm outputs
- * Choice of sensing head to match application
- * Standard and close focus optics available
- * Accessories for cooling and air purging
- * Field interchangeable sensing heads

Common Industrial Applications

- ➔ Plastics
- ➔ Paper & Pulp Converting
- ➔ Chemicals
- ➔ Food Processing
- ➔ Pharmaceutical
- ➔ Electronics
- ➔ Construction
- ➔ Industrial Maintenance

Non-contact Temperature Measurement for Industrial Processes

The NCIT Plus Series is a versatile, two-piece temperature monitoring system that combines a compact, value-priced monitor with an infrared sensing head. The heart of the system is the 1/8 DIN NCIT Plus Monitor which provides advanced infrared processing capabilities including peak and valley hold, averaging, and user-adjustable offset.

Advances in optical and electronic design, originally developed for high-end infrared systems, have been adapted to this low-cost line without compromise in performance when compared to infrared sensors that cost twice as much just a few years ago.

The **NCIT Plus** models can't scratch, tear, smear or contaminate because they don't make contact with your product. They are easier and safer to install and maintain because they can be positioned away from hot and hazardous processes and moving products.

They remain accurate over a longer period of time because they're not subjected to the abuse that a contact device receives. And they deliver much faster response time than contact thermocouples, while rivaling their accuracy and repeatability.

In the long run, non-contact temperature measurement can help you improve quality, speed production, and save money.

1/8 DIN NCIT Plus Monitor

Along with its large 4-digit LED display, the monitor provides a user-defined 4-20mA or thermocouple output. Two adjustable setpoints/deadbands control 5V alarm outputs or optional 3A mechanical relays. The **NCIT Plus Monitor** accepts universal 110-220 Vac power input and provides a 24 Vdc / 50 mA excitation voltage for loop power to external sensors. All monitor functions are configured via the front panel, including °C/°F switching.

The **NCIT Plus Monitor** provides adjustable emissivity and ambient compensation when used with the **NCIT Plus Standard** infrared sensing heads.

Standard Sensing Heads

These high performance, 8-14 micron sensors combine current loop driven signals with high resolution optics.

The **NCIT Plus Standard w/ Laser** sensing head comes equipped with laser sighting for alignment in hard to reach locations, or to small or distant targets. The 50:1 distance to spot (D:S) ratio provides the capability of measuring a spot size of 1.2" at a distance of 5 ft.

The **NCIT Plus Standard** sensing head's D:S ratio of 35:1 allows a spot size of 1.7" at a distance of 5 ft.

Proven Technology

Non-contact infrared temperature sensors have proven advantageous and reliable in many industries for over 25 years. Tempco brings this technology to you at a price competitive with thermocouples.

Non-contact Infrared Temperature Measurement System — NCIT Plus Series

Measurement Specifications

Temperature Range (All Sensor Heads):	0 to 1000°F (-18 to 538°C)
Spectral Response:	Standard & Laser: 8 to 14 μm
Optical Resolution:	Laser: 50:1, close focus 45:1 Standard: 35:1, close focus 30:1
System Accuracy:	$\pm 1\%$ or $\pm 2^\circ\text{F}$ ($\pm 1^\circ\text{C}$), whichever is greater
System Repeatability:	$\pm 0.5\%$ or $\pm 2^\circ\text{F}$ ($\pm 1^\circ\text{C}$), whichever is greater
Response Time – (95% of final reading):	Standard & Laser: 500 ms
Emissivity:	Digitally adjustable, 0.1 to 1.09 by increments of 0.01 steps
Signal Processing:	Peak and valley hold (up to 998 sec, 999 = infinite hold with external reset), Variable averaging filter (up to 60 sec), T-ambient: fixed background ambient temperature compensation

Electrical Specifications

Power Supply:	110 /220 VAC, $\pm 20\%$, 50-60 Hz
Inputs:	User configurable inputs for Laser or Standard sensing heads, any 5-0 Vdc or 4-20 mA sensor, or thermocouple (J, K, E, N, R, S, T) External reset input to reset peak/valley hold
Outputs-Signal:	4-digit, LED display, $^\circ\text{F}/^\circ\text{C}$ selectable. User configurable 4-20 mA current or thermocouple output (J, K, E, N, R, S, T)
Alarm Output:	Two adjustable setpoints with deadbands controlling +5 Vdc alarm outputs or optional 3A mechanical relays
DC Supply Output:	24 Vdc / 50 mA excitation voltage for powering external sensors

Sensor Specifications

Environmental Rating:	Monitor Front Panel: NEMA 12 (IP54) Laser/Standard Head: NEMA 12 (IP65)
Ambient Temperature:	32° to 120°F (0 to 50°C)
Monitor	32° to 150°F (0 to 65°C)
Laser/Standard Head	laser shuts off automatically at 120°F (50°C)
With water cooling	32° to 350°F (0 to 177°C)
With air cooling	32° to 250°F (0 to 120°C)
Relative Humidity:	10 to 95%, non-condensing
Monitor Dimensions:	1/8 DIN, 96 × 48 × 120 mm 1.9" × 3.78" × 4.75"
Cutout Dimensions:	1.75" × 3.63" (92 × 44 mm)
Weight:	Monitor: 320g (0.7 lb.)

Distance to Spot Ratio—Standard

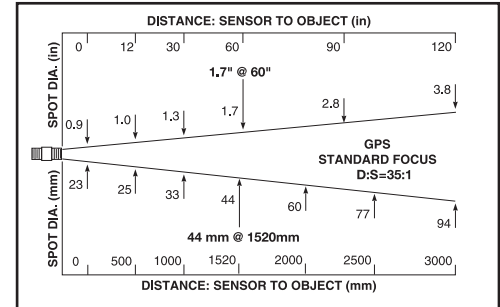

Distance to Spot Ratio—Standard Close Focus

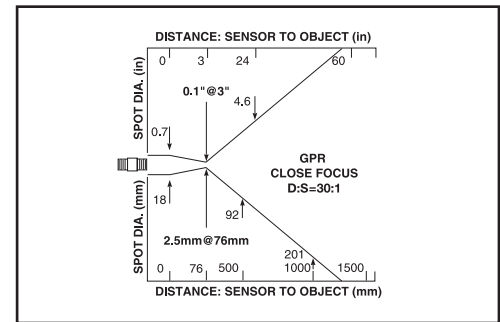

Distance to Spot Ratio—Laser

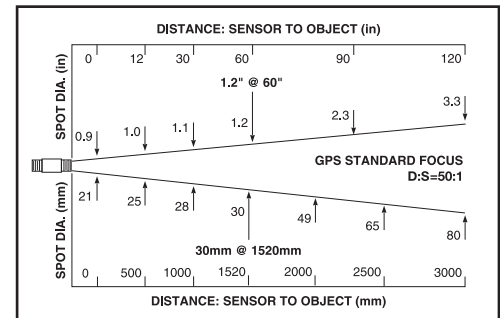

Distance to Spot Ratio—Laser Close Focus

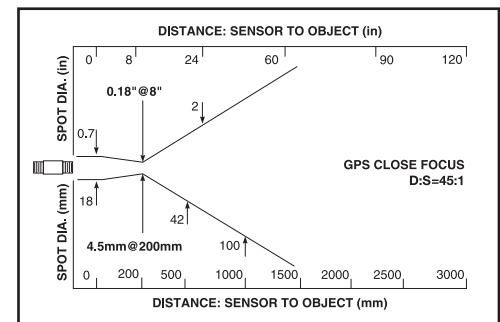

Infrared Temperature Measurement — NCIT Plus Series

NCIT Plus Monitor

- REN01001** 1/8 DIN Panel Meter 110/220VAC
w/ 5 Vdc alarm outputs
- REN01003** 1/8 DIN Panel Meter 110/220VAC
with optional 3A relays for alarm outputs
- REN01002** Light duty aluminum mounting bracket to allow
for sub-panel mounting

NCIT Plus Standard Sensing Heads (includes mounting bracket and nut)

- REN01101** Standard focus infrared sensing head, 35:1 optics
- REN01102** Standard – close focus infrared sensing head,
30:1 optics
- REN01120** NIST/DKD calibration certificate (also for
water cooled) **Must be ordered with unit.**

With Water Cooled Housing and Lens Air Purge Collar

- REN01110** Standard focus infrared sensing head
- REN01111** Standard – close focus infrared sensing head

NCIT Plus Standard with Laser Sight Sensing Heads

(includes an adjustable mounting bracket and nut,
13 ft. (4m) cable for between the sensor and the
laser switch box, and 26 ft. (8m) cable to connect
the laser switch box to the NCIT Plus Monitor)

- REN01103** Standard focus infrared sensing head, 50:1 optics
- REN01104** Standard – close focus infrared sensing head,
45:1 optics
- REN01121** NIST/DKD calibration certificate (also for
water cooled) **Must be ordered with unit.**

With Water Cooled Housing and Lens Air Purge Collar

- REN01112** Standard focus infrared sensing head
- REN01113** Standard – close focus infrared sensing head

Air/Water Cooled Sensing Head

The Air/Water-Cooled Housing option allows the laser or standard sensor to be used in ambient temperatures **up to 250°F (121°C) with air cooling**, or **350°F (177°C) with water cooling**. It is supplied with two 1/8" NPT brass fittings.

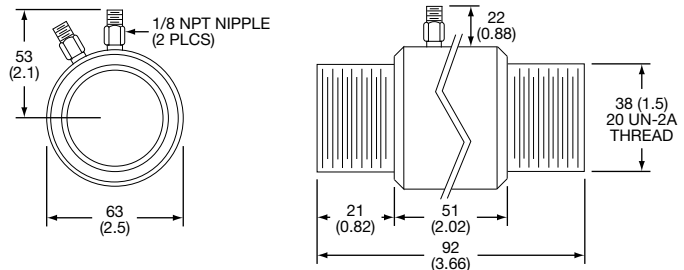

Air flow at 77°F (25°C) should be **3 to 5 cfm** (1.4 to 2.4 liters/sec) with a pressure drop across the housing of 2 to 5 PSIG (0.14 to 0.35 kg/cm²). Water flow should be approximately **0.5 gallons (2 liters) per minute**; water temperature should be 50 to 80°F (10 to 27°C) for efficient cooling.

All units ordered with the Air/Water-Cooled Housing include the Air Purge Collar to avoid condensation and lens damage.



Note: The laser-equipped standard sensing head is 125 mm (4.92") long. The laser shuts off automatically at 120°F (50°C).

Standard / Laser Sensing Heads

All Standard sensors are supplied with a fixed bracket and a mounting nut. Alternatively, the sensor may be mounted through a hole, on a customer-supplied bracket, with the pipe adapter, or with other accessories. Avoid installing the sensor cable in noisy electrical environments. In this environment, it is recommended to install the cable in conduit. A conduit adapter accessory is available for this purpose.



Note: The laser-equipped standard sensing head is 125 mm (4.92") long.

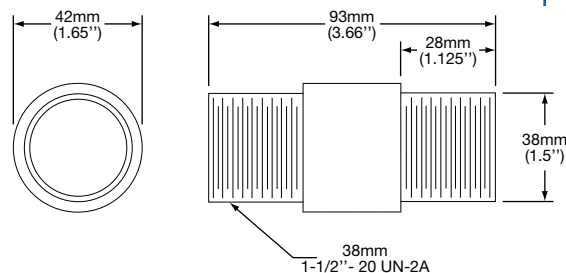

Infrared Temperature Measurement — NCIT Plus Series Accessories

Pipe Adapter:

The Pipe Adapter is used to connect the Standard or Laser Head to a 1.5 inch NPT pipe thread.

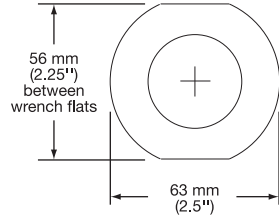

REN00206

Conduit Adapter

The Pipe Adapter is used to connect the Standard or Laser Head to a 1/2-inch NPT conduit fitting.

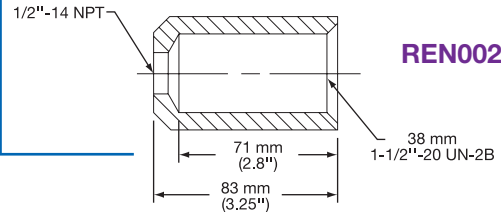

REN00205

Lens Air Purge Collar:

The Air Purge Collar accessory is used to keep dust, moisture, airborne particles and vapors away from the lens. It may be installed before or after the bracket. Air flow should be a maximum of 1-3 cfm (0.5-1.5 liters/sec). Clean or "instrument" air is recommended to avoid contaminants from settling on the lens.

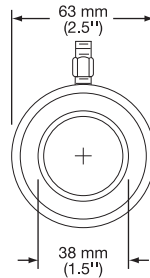

REN00204

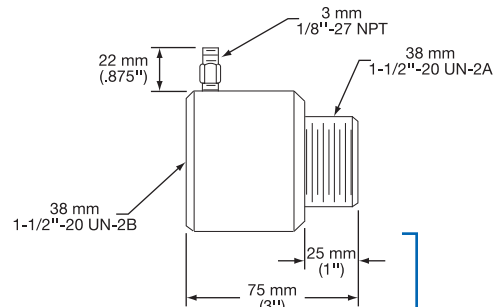

NCIT Plus Standard Sensing Head Cables

5 conductor cables for connecting the standard sensing head to the panel meter.

REN01201	13 ft. (4m) – Regular temperature
REN01202	13 ft. (4m) – High temperature for Air/Water cooled Sensing Head
REN01203	26 ft. (8m) – Regular temperature
REN01204	26 ft. (8m) – High temperature for Air/Water cooled Sensing Head

Additional Accessories

REN00208	Fixed mounting bracket for the regular sensing head
REN00213	Adjustable mounting bracket for the regular sensing head
REN00207	Mounting nut

Used in conjunction with the Standard or Laser Sensing Head.

Ordering Information

Choose the **NCIT Plus, accessories, and/or options** desired, and order by the associated part number.

Standard lead time is stock to 3 weeks.

⚠ WARNING: Cancer and Reproductive Harm - www.P65Warnings.ca.gov.

Temperature Transmitters

2-Wire Miniature Universal Temperature/Process Transmitters



ETM1



ETM2



ETM3

PROGRAMMABLE
in the field with your PC and easy to use software.
Can be ordered pre-programmed from Tempco.

Temperature transmitters are used for a variety of reasons. The use of temperature transmitters can eliminate the need for long costly runs of thermocouple wire with less expensive copper signal wire. When the environment is electrically noisy, sending a 4-20 mA signal to the control panel reduces the chance of error.

Design Features:

- * Three levels of accuracy: *ETM1*— $\pm 0.15\%$ of span
ETM2— $\pm 0.10\%$ of span
ETM3— $\pm 0.05\%$ of span
- * Accepts 11 thermocouple types and 3- or 4-wire RTD sensors
- * Field programmable with easy to use Windows®-based configuration software and a PC
- * Sensor break monitoring, programmable for upscale or downscale
- * Full access to all features while in operation
- * Temperature linear output
- * NAMUR-compliant
- * Configuration, editing & reading without external power
- * Easy wiring through the large center hole

The **Tempco ETM Series** of 2-wire transmitters are offered in isolated, non-isolated and high precision isolated versions. They are designed to fit in a standard aluminum, iron or plastic industrial connection head, DIN size B or larger.

Additional Design Features for the Isolated Versions

- * Fully universal, linearized and isolated 3/4 wire RTD, T/C, mV and Ohm
- * Sensor and system error correction
- * Low sensor isolation detection
- * Simplified loop check up with calibration output

The **ETM Transmitters** are built using surface mount components and employ digital technology with non-volatile memory to retain the configuration after programming and the cable is removed.

Ordering Code: ETM 1 2 3 4 5 6

Isolation BOX 1

- 1** = Non-Isolated
- 2** = Isolated
- 3** = Isolated, High Precision

Input Signal BOX 2

- R** = RTD-Pt100
- S** = RTD-D100
- H** = RTD-Pt100
- T** = Thermocouple
- M** = mV (ETM2 & ETM3 only)
- P** = Potentiometer (ETM2 & ETM3 only)

BOX 3

If **thermocouple input**, enter thermocouple **Type Code**: (if not enter **0**)

- J** = J thermocouple
- K** = K thermocouple
- E** = E thermocouple
- B** = B thermocouple
- C** = C thermocouple
- L** = L thermocouple
- N** = N thermocouple
- R** = R thermocouple
- S** = S thermocouple
- T** = T thermocouple
- U** = U thermocouple

Minimum Range BOX 4

In degrees (t/c and RTD)
mV & ohms (isolated only)
Backfill unused boxes with 0's
Example: 10° = 0010

Maximum Range BOX 5

In degrees (t/c and RTD)
mV & ohms (isolated only)
Backfill unused boxes with 0's
Example: 950° = 0950

Units: BOX 6

- F** = °F
- C** = °C
- M** = mV Ohms (isolated only)
- R** = Ohms (isolated only)

⚠ WARNING: Cancer and Reproductive Harm - www.P65Warnings.ca.gov.

2-Wire Miniature Universal Temperature/Process Transmitters

ETM Specifications

Parameter	ETM1 Non-Isolation	ETM2 Isolation	ETM3 High Precision Isolation
Typical Accuracy:	±0.15% of span	±0.10% of span	±0.05% of span
Galvanic Isolation:	No	1500 Vac, 1 min.	3750 Vac, 1 min.
Thermocouple Types:	J, K, E, B, C, L, N, R, S, T, U		
RTD Types, 3 & 4 wire:	PT100 IEC $\alpha=0.00385$, PT1000 IEC $\alpha=0.00385$ and others; Consult Tempco		
Input mV:	N/A	-10 to +500 mV	-10 to +500 mV
Potentiometer / Resistance:	N/A	3/4 wire, 0-2000 Ω	3/4 wire, 0-2000 Ω
Maximum T/C Wire Resistance:	500 Ω	500 Ω	500 Ω
Power Supply:	6.5 to 36 Vdc	6.5 to 36 Vdc	6.5 to 36 Vdc
Output	4 to 20mA, 20-4mA	4 to 20mA, 20-4mA	4 to 20mA, 20-4mA
Linearity Thermocouple:	±0.2%	±0.2%	±0.1%
Linearity RTD:	±0.1%	±0.1%	±0.05%
Sensor Break Monitoring:	Upscale or Downscale, Programmable		
Minimum Span Calibration			
T/C:	2 mV	2 mV	2 mV
RTD:	18°F/10°C	18°F/10°C	18°F/10°C
Potentiometer:	N/A	10 Ω	10 Ω
Temperature Operation & Storage:	-40° to +185°F/-40° to +85°C		
Relative Humidity:	0 to 95%, non-condensing		
Mounting:	DIN B connection head or larger		
Protection: Housing/Terminals:	IP 65/IP 00	IP 50/IP 10	IP 50/IP 10

Common Pre-Programmed Miniature Temperature Transmitters

Part Number	Version/ Isolation	Input	Range		Unit
			Zero	Span	
ETM20103	ETM1/no	K tc	0	200	°F
ETM20104	ETM1/no	J tc	0	200	°F
ETM20105	ETM2/yes	RTD	0	200	°F
ETM20106	ETM1/no	K tc	0	500	°F
ETM20107	ETM1/no	J tc	0	500	°F
ETM20108	ETM2/yes	RTD	0	400	°F
ETM20109	ETM1/no	K tc	0	200	°C
ETM20110	ETM1/no	J tc	0	200	°C
ETM20111	ETM1/no	K tc	0	400	°C
ETM20112	ETM1/no	J tc	0	400	°C
ETM30003	ETM3/yes	K tc	0	500	°F
ETM30004	ETM3/yes	J tc	0	500	°F
ETM30005	ETM3/yes	RTD	0	400	°F
ETM30006	ETM3/yes	K tc	0	200	°C
ETM30007	ETM3/yes	J tc	0	200	°C
ETM30008	ETM3/yes	RTD	0	200	°C



Note: For dimensions and wiring information, see page 12-48.

All Items Available from Stock

Un-Programmed Miniature Transmitters

ETM20001 For Non-Isolated Version
ETM20002 For Isolated Version
ETM30002 For High Precision Isolated Version

Universal Field Programming Kit

For programming ETM30002 miniature head mounted Isolated High Precision transmitters and all other Tempco transmitters for sensor type and range. Includes USB Interface and, all required cables and software. Includes hard carrying case. Connects to a USB port on the PC. Compatible with 32 or 64 bit Windows XP (SP2+), Vista, Windows 7, 8, 8.1, or 10.

Part Number: **ETM90006**

Lite Field Programming Kit

For programming ETM20001, ETM20002, miniature head mounted non-isolated and isolated transmitters for sensor type and range. Includes USB Interface and all required cables and software. Includes storage bag. Connects to a USB port on the PC. Compatible with 32 or 64 bit Windows XP (SP2+), Vista, Windows 7, 8, 8.1, or 10.

Part Number: **ETM90007**

Ordering Information

Order a common unit by part number from the table or create an ordering code by filling in the boxes with the appropriate number and/or letter designation for your requirements and a part number will be assigned, or choose a pre-assigned configuration.

WARNING: Cancer and Reproductive Harm - www.P65Warnings.ca.gov.

Temperature Transmitters

2-Wire Panel Rail Mount Universal Temperature/Process Transmitters

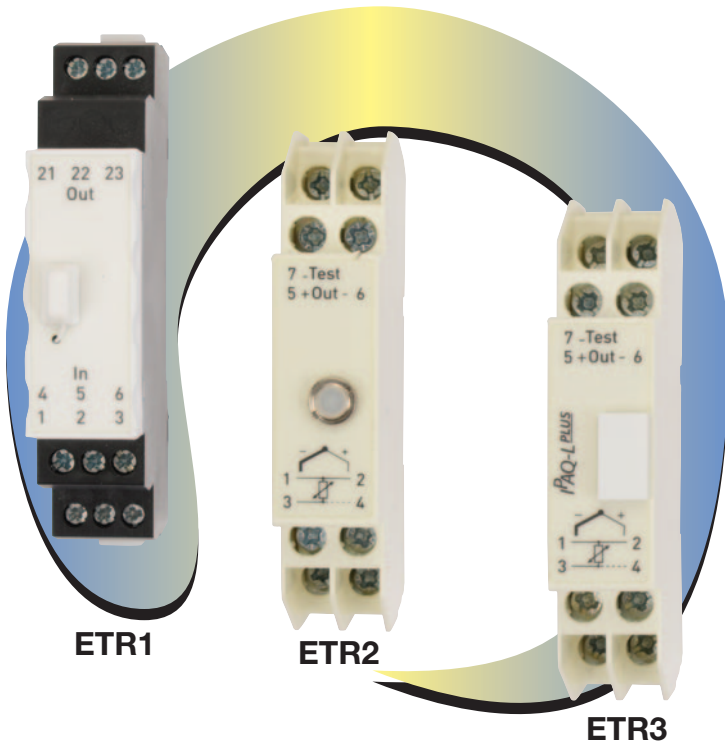

PROGRAMMABLE
in the field with your PC and easy to use software.
Can be ordered pre-programmed from Tempco.

Design Features:

- * Three levels of accuracy: *ETR1* — $\pm 0.15\%$ of span
ETR2 — $\pm 0.10\%$ of span
ETR3 — $\pm 0.05\%$ of span
- * Accepts 11 thermocouple types and 3- or 4-wire RTD sensors
- * Field programmable with easy to use Windows®-based configuration software and a PC
- * Sensor break monitoring, programmable for upscale or downscale
- * Full access to all features while in operation
- * Temperature linear output
- * NAMUR-compliant
- * Configuration, editing & reading without external power
- * Easy wiring with captive clamp style wire connections

Additional Design Features for the Isolated Versions

- * Fully universal, linearized and isolated 3/4 wire RTD, T/C, mV and Ohm
- * Sensor and system error correction
- * Low sensor isolation detection
- * Simplified loop check up with calibration output

The **ETR Transmitters** are built using surface mount components and employ digital technology with non-volatile memory to retain the configuration after programming and the cable is removed.

Temperature transmitters are used for a variety of reasons. The use of temperature transmitters can eliminate the need for long costly runs of thermocouple wire with less expensive copper signal wire. When the environment is electrically noisy, sending a 4-20 mA signal to the control panel reduces the chance of error.

The **Tempco ETR Series** of 2-wire transmitters is offered in isolated, non-isolated and high precision isolated versions. They are designed to fit directly on a standard 35 mm DIN rail.

Ordering Code: ETR 1 2 3 4 5 6

Isolation BOX 1
1 = Non-Isolated
2 = Isolated
3 = Isolated, High Precision

Input Signal BOX 2
R = RTD-Pt100
S = RTD-D100
H = RTD-Pt100
T = Thermocouple
M = mV (ETM2 & ETM3 only)
P = Potentiometer (ETR2 & ETR3 only)

BOX 3
 If **thermocouple input**, enter thermocouple **Type Code**: (if not enter 0)
J = J thermocouple
K = K thermocouple
E = E thermocouple
B = B thermocouple
C = C thermocouple
L = L thermocouple
N = N thermocouple
R = R thermocouple
S = S thermocouple
T = T thermocouple
U = U thermocouple

Minimum Range BOX 4
 In degrees (t/c and RTD)
 mV & ohms (isolated only)
Backfill unused boxes with 0's
 Example: 10° = 0010

Maximum Range BOX 5
 In degrees (t/c and RTD)
 mV & ohms (isolated only)
Backfill unused boxes with 0's
 Example: 950° = 0950

Units: BOX 6
F = °F
C = °C
M = mV Ohms (isolated only)
R = Ohms (isolated only)

⚠ WARNING: Cancer and Reproductive Harm - www.P65Warnings.ca.gov.



2-Wire Panel Rail Mount Universal Temperature/Process Transmitters

ETR Specifications

Parameter	ETR1 Non-Isolation	ETR2 Isolation	ETR3 High Precision Isolation
Typical Accuracy:	±0.15% of span	±0.10% of span	±0.05% of span
Galvanic Isolation:	No	1500 Vac, 1 min.	3750 Vac, 1 min.
Thermocouple Types:	J, K, E, B, C, L, N, R, S, T, U		
RTD Types, 3 & 4 wire:	PT100 IEC α=0.00385, PT1000 IEC α=0.00385 and others; Consult Tempco		
Input mV:	N/A	-10 to +500 mV	-10 to +500 mV
Potentiometer / Resistance:	N/A	3/4 wire, 0-2000 Ω	3/4 wire, 0-2000 Ω
Maximum T/C Wire Resistance:	500 Ω	500 Ω	500 Ω
Power Supply:	8 to 32 Vdc	8 to 30 Vdc	7.5 to 36 Vdc
Output	4 to 20mA, 20-4mA	4 to 20mA, 20-4mA	4 to 20mA, 20-4mA
Linearity Thermocouple:	±0.2%	±0.2%	±0.1%
Linearity RTD:	±0.1%	±0.1%	±0.05%
Sensor Break Monitoring:	Upscale or Downscale, Programmable		
Minimum Span Calibration			
T/C:	2 mV	2 mV	2 mV
RTD:	18°F/10°C	18°F/10°C	18°F/10°C
Potentiometer:	N/A	10 Ω	10 Ω
Temperature Operation & Storage:	-4° to +158°F/-20° to +70°C		
Relative Humidity:	0 to 95%, non-condensing		
Mounting:	DIN, 35 mm (for DIN rail see page 13-95)		
Protection: Housing/Terminals:	IP 20	IP 20	IP 20

Common Pre-Programmed Rail Mount Temperature Transmitters

Part Number	Version/ Isolation	Input	Range		Unit
			Zero	Span	
ETR20101	ETR1/no	K tc	0	200	°F
ETR20102	ETR1/no	J tc	0	200	°F
ETR20103	ETR2/yes	RTD	0	200	°F
ETR20104	ETR1/no	K tc	0	500	°F
ETR20105	ETR1/no	J tc	0	500	°F
ETR20106	ETR2/yes	RTD	0	400	°F
ETR20107	ETR1/no	K tc	0	200	°C
ETR20108	ETR1/no	J tc	0	200	°C
ETR20109	ETR1/no	K tc	0	400	°C
ETR20110	ETR1/no	J tc	0	400	°C
ETR30002	ETR3/yes	K tc	0	500	°F
ETR30003	ETR3/yes	J tc	0	500	°F
ETR30004	ETR3/yes	RTD	0	400	°F
ETR30005	ETR3/yes	K tc	0	200	°C
ETR30006	ETR3/yes	J tc	0	200	°C
ETR30007	ETR3/yes	RTD	0	200	°C



Note: For dimensions and wiring information, see page 12-49.

Un-Programmed Rail Mount Transmitters

ETR20001 For Non-Isolated version
ETR20002 For Isolated version
ETR30001 For Isolated High Precision version

Universal Field Programming Kit

For programming ETR30001 DIN rail mount Isolated High Precision transmitters and all other Tempco transmitters for sensor type and range. Includes USB Interface and, all required cables and software. Includes hard carrying case. Connects to a USB port on the PC. Compatible with 32 or 64 bit Windows XP (SP2+), Vista, Windows 7, 8, 8.1, or 10.

Part Number: **ETM90006**

Lite Field Programming Kit

For programming ETR20001, ETR20002, DIN rail mount non-isolated and isolated transmitters for sensor type and range. Includes USB Interface and all required cables and software. Includes storage bag. Connects to a USB port on the PC. Compatible with 32 or 64 bit Windows XP (SP2+), Vista, Windows 7, 8, 8.1, or 10.

Part Number: **ETM90007**

All Items Available from Stock

Ordering Information

Order a common unit by part number from the table or create an ordering code by filling in the boxes with the appropriate number and/or letter designation for your requirements and a part number will be assigned, or choose a pre-assigned configuration.

WARNING: Cancer and Reproductive Harm - www.P65Warnings.ca.gov.

Wiring Diagrams for 2-Wire Miniature Head Temperature/Process Transmitters

ETM1 Non-Isolated

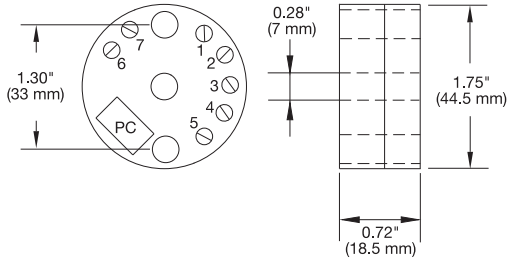

ETM2 Isolated and ETM3 Isolated High Precision

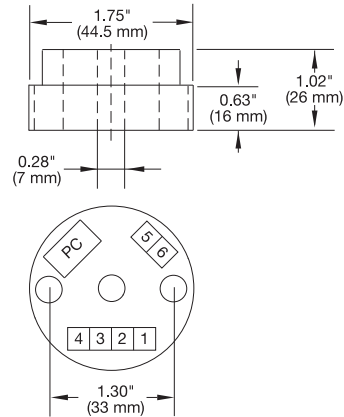

Input Connections for ETM1, ETM2 and ETM3

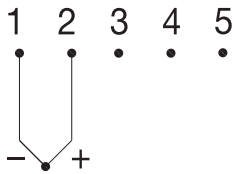

Thermocouple

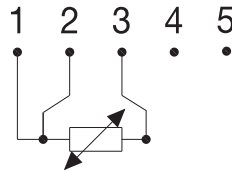

RTD- PT100, PT1000
3-wire

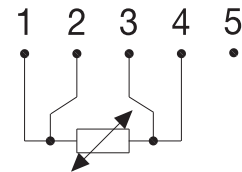

RTD- PT100, PT1000
4-wire

Additional Input Connections for Isolated ETM2 and ETM3

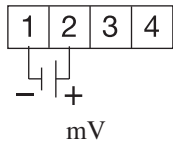

mV

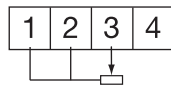

Potentiometer 3-wire

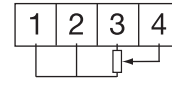

Potentiometer 4-wire

Output Connections for ETM1, ETM2 and ETM3

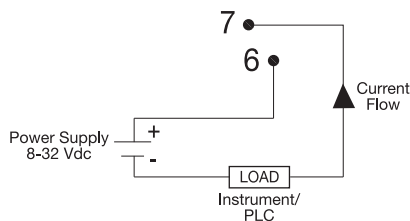

ETM1

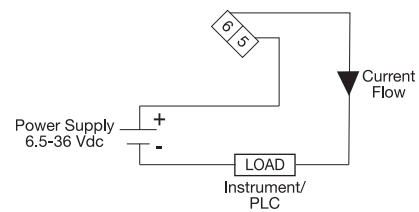

ETM2 & ETM3

Wiring Diagrams for 2-Wire DIN Rail Mount Temperature/Process Transmitters

ETR1 Non-Isolated

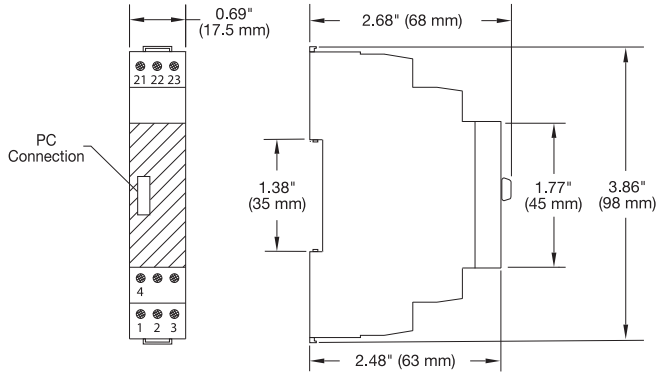

ETR2 Isolated and ETR3 Isolated High Precision

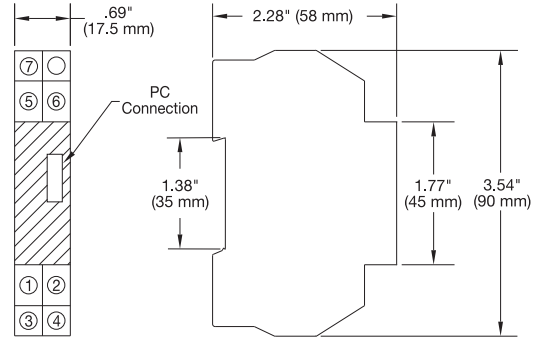

Input Connections for ETR1, ETR2 and ETR3

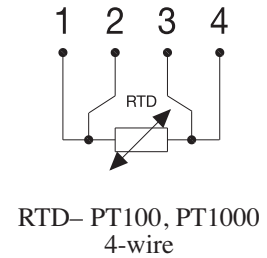
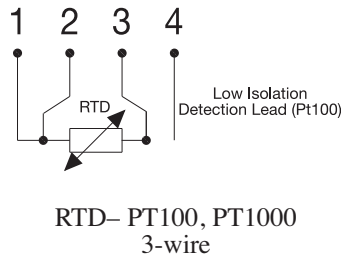
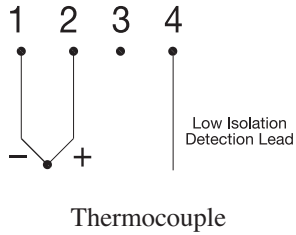

Additional Input Connections for Isolated ETR2 and ETR3

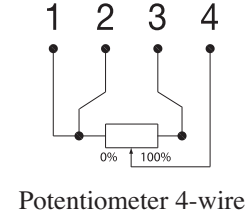
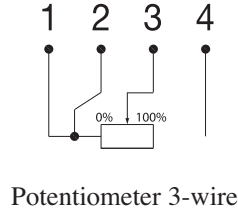
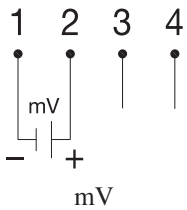

Output Connections for ETR1, ETR2 and ETR3

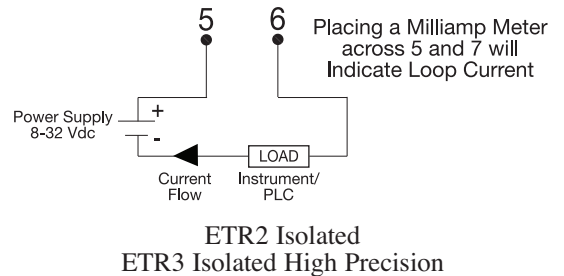
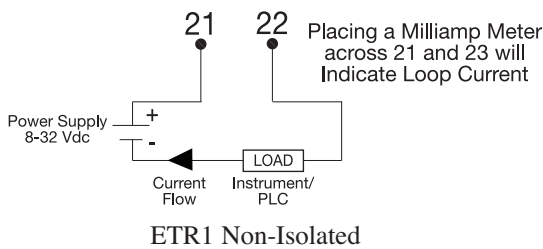

Temperature Displays

Loop Powered (4-20mA) LCD Temperature/Process Indicator in Standard and Heavy Duty Connection Heads

The EMT1 & EMT2 are digital indicators for installation directly in a 4-20mA signal loop without the requirement of external power.

It is provided in a sensor connection head, ready for attachment to a thermowell or industrial sensor assembly.

The indicator is equipped with high contrast easy-to-read LCD digits.

Scaling the display is easily accomplished, without a reference signal, by three push buttons for any values between -9999 and 9999.



Shown with TC Assembly
(not included)

EMT10001



EMT20001

Design Features:

- * Installation directly in a 4-20mA signal loop without the need for an external power supply.
- * Works in conjunction with an ETM In-Head transmitter, sold separately
- * Minimal voltage drop
- * High contrast, 4-digit LCD display
- * Simple push-button scaling without a reference signal
- * Any range between -9999 and 9999 for the 4-20mA input
- * Labels for different engineering units are included
- * Typical accuracy of $\pm 0.1\%$ allows for high precision readouts.
- * HART transparent
- * NEMA 4X / IP65 / IP66 protection for display housings

Specifications

	ETM1	ETM2
Input current	4 - 20 mA	
Operating range	3.8 - 22 mA	3.5 - 30 mA
Voltage drop	2.5 Vdc	1.5 Vdc
Indication	Black LCD with 4 digits include minus sign	
Display	Black LCD with 4 digits include minus sign	
Digit height	12 mm	12.7 mm
Decimals	Selectable, 0 to 3	
Engineering units	Set of labels included	
Response time	Approx. 0.5 sec.	0.25 to 2 sec.
Scale setting	3 push buttons	
Operating Temperature	ETM1: -4 to +158°F / -20 to +70°C ETM2: -13 to +158°F / -25 to +70°C	
Typical Accuracy	$\pm 0.1\%$	0.05%
Protection	NEMA 4X / IP 65	NEMA 4X / IP 66 FM/CSA Class 1, Div 1 & 2
Wire Connection	16 ga. or smaller	
Mounting	Process: 1/2"-14 NPT Conduit: 3/4"-14 NPT	3/4"-14 NPT x 3

Ordering Information

Order by the Part Number EMT10001 or EMT20001.

Standard lead time is stock to 2 weeks.



Note:

The in-head temperature transmitters are sold separately; see page 12-44.

WARNING: Cancer and Reproductive Harm - www.P65Warnings.ca.gov.

EMT10001

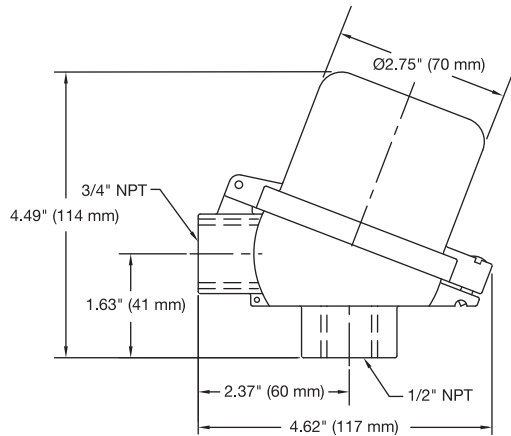

EMT20001

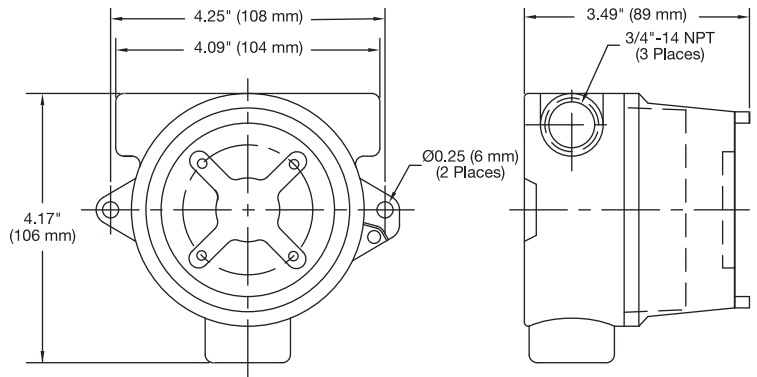

EMT10001 & EMT20001 Wiring with Internal Transmitter

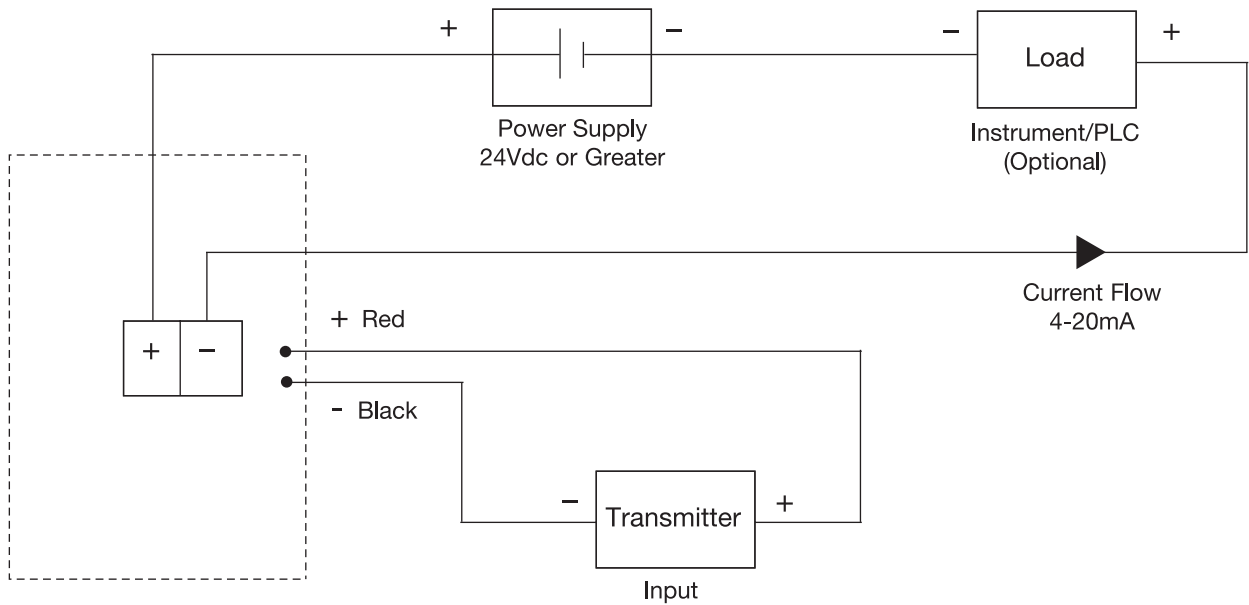

EMT10001 & EMT20001 Wiring with External Transmitter

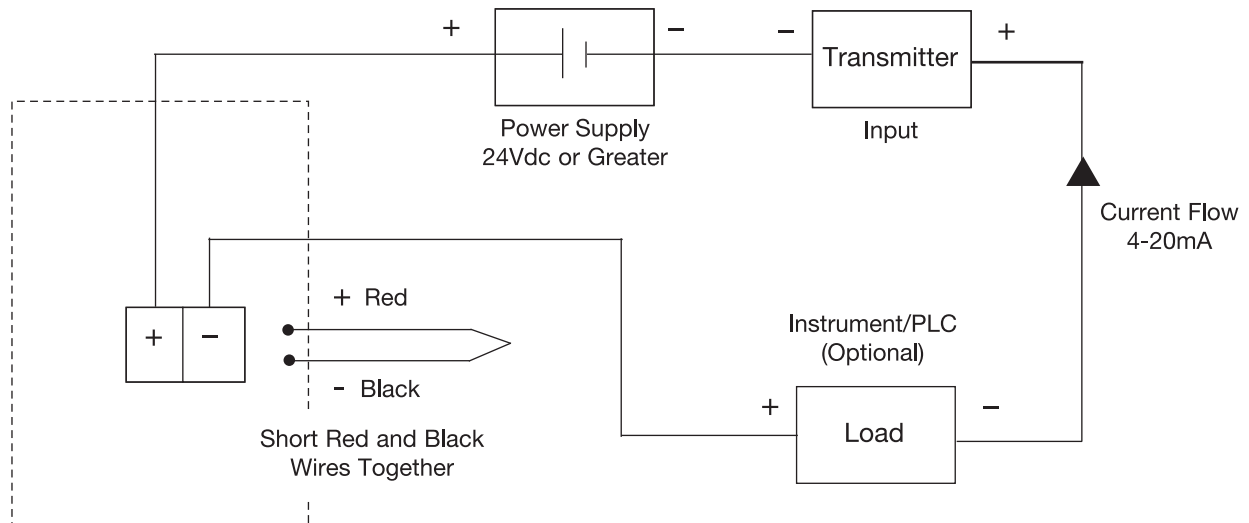

Portable 6-Station Temperature Monitor



Design Features

- * Thermocouple calibrations available are K, or J linearized in four sections for good accuracy.
- * RTD Cold Junction compensates accurately for ambient temperature changes as fast as 2°/min.
- * High Impedance Circuit allows use of probes with up to 1000 ft. of 24 ga. wire; several transformer-isolated monitors can connect to the same probe.
- * 1/2" High LCD Display is sunlight readable.
- * Powered by 9V alkaline "transistor" battery.
- * Durable Rotary Selector for displaying 6 thermocouple inputs.
- * Large Pointer Selector Knob clearly indicates the monitored location.
- * Polymer-Coated Circuit will perform indefinitely even in high humidity environments.
- * Made in the United States and warranted against material or workmanship defects for 1 year.

Multi-Station Portable Thermocouple Monitor

These thermocouple monitors were designed to assist field technicians with testing or calibrating HVAC/refrigeration systems, baking/curing ovens, motors, engines, and much more. Instant response circuits allow a technician to compare up to 6 temperature probes quickly.

These circuits have been optimized to deliver accuracy and stability over a wide environmental range. The durable carrying case is compact and features a compartment for storing wire and probes.

Specifications

Display Range:	-199 to 1999 °F or °C
Measuring Accuracy:	±1/2% of reading ±1°
Ambient Oper. Temp.:	-5° to 140°F (-21° to 60°C)
Relative Humidity:	90% max., non-condensing
Cold Junction Offset:	1° max. for 32° to 110°F (0° to 43°C)
Display Updates:	3 times per second
LCD Height:	0.5" (12.7 mm) high
Construction:	High-density polyethylene case, aluminum panel with meter and miniature thermocouple jacks
Dimensions:	12" x 8" x 3"
Power Requirement:	9 Vdc (9V "transistor" alkaline battery)
Weight:	2.0 lb. (0.9 kg.)

DISPLAY RANGE

Thermocouple Type	°F		°C	
	Min.	Max.	Min.	Max.
J-Fe/Constantan	-60	1400	-50	750
K-Chromel™/Alumel™	-60	1999	-50	1100

TEMPERATURE MONITORS

No. of Inputs	Scale	Thermocouple	
		J	K
6	°F	DTM30010	DTM30015
6	°C	DTM30020	DTM30025

Ordering Information

Choose the Part Number of the **Temperature Monitor** that best fits the needs of your application.

A **120 Vac model** (with optional LED display) is available; please consult Tempco for order information.

Standard lead time is stock to 3 weeks.

12-Station Temperature Monitor

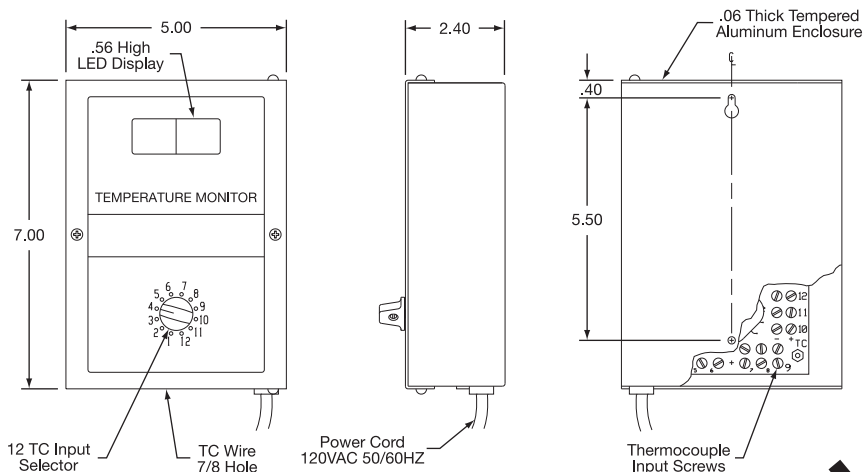

Design Features

- * Thermocouple calibrations available are T, K, J, or E linearized over sections for good accuracy.
- * RTD Cold Junction compensates accurately for ambient temperature changes as fast as 2°/min.
- * 1/2" high Red LED Display provides excellent readability.
- * Large Pointer Selector Knob clearly indicates the monitored location of 12 locations.
- * Polymer-Coated Circuit will perform indefinitely even in high humidity environments.
- * Made in the United States and warranted against material or workmanship defects for 1 year.

12-Station Temperature Monitor

DISPLAY RANGE

Thermocouple Type	Min. °F	Max. °F	Min. °C	Max. °C
J-Fe/Constantan	-60	1400	-50	750
K-Chromel [®] /Alumel [®]	-50	1975	-50	1100

These thermocouple monitors were designed for industrial or commercial applications that require monitoring of up to 12 locations economically. The circuits have been optimized to deliver accuracy and stability over a wide environmental range. Typical applications include monitoring HVAC systems, baking/curing ovens, food or medical freezers, solar installations, refrigeration equipment, motor bearings, engines, etc.

Specifications

Display Range:	-199 to 1999 °F or °C
Measuring Accuracy:	±1/2% of reading ±1°
Ambient Oper. Temp.:	-15° to 130°F (-26° to 54°C)
Relative Humidity:	90% max., non-condensing
Cold Junction Offset:	1° max. for 32° to 110°F (0° to 43°C)
Display Updates:	3 times per second
LED Height:	0.56" (14 mm) high
Construction:	Aluminum enclosure, surface mounting with swing-out front panel
Power Requirement:	120 or 230 Vac, 50/60 Hz.
Power Cord Length:	5 ft.
Weight:	1.7 lb. (0.8 kg.)

TEMPERATURE MONITORS			
Volts AC	Scale	Thermocouple J K	
120	°F	DTM20010	DTM20015
120	°C	DTM20020	DTM20025
230	°F	DTM20030	DTM20035
230	°C	DTM20040	DTM20045



Note: 230V units have internal terminal connections for AC power input.

Typical Applications

- ♦ Monitoring HVAC Systems
- ♦ Baking/Curing Ovens
- ♦ Food or Medical Freezers
- ♦ Molding Machines
- ♦ Industrial Process Equipment
- ♦ Refrigeration Equipment
- ♦ Motor Bearings
- ♦ Engines

Ordering Information

Choose the Part Number of the **Temperature Monitor** that best fits the needs of your application. If calibrations of type E or T are required, consult Tempco for part number.

Standard lead time is stock to 3 weeks.

Bimetal Dial Thermometers

Bimetal Dial Thermometers for Industrial Applications

Typical Applications

- ➔ Oil, Gas & Petrochemical
 - ➔ Waste Water
 - ➔ Pharmaceutical
 - ➔ Compost
- ➔ Food & Beverage
 - ➔ Military
 - ➔ Paper and Pulp
 - ➔ Dairy
 - ➔ Mining
- ➔ Power Generation
 - ➔ Utilities
 - ➔ Refrigeration
 - ➔ Marine
 - and Many More !!!

Bimetal Dial Thermometers are ideal for when you need a simple, "local" temperature display.

Tempco offers 2 styles: Backmounted and Adjustable Angle, each available with either 3" or 5" dials.

Backmounted Bimetal Dial Thermometers

Design Features

- * All Stainless Steel Construction
- * Hermetically Sealed (ASME B40.3)
- * Accurate to 1% of Full Scale
- * Standard External Reset
- * Silicone Fillable for Vibration Resistance
- * 1/2" NPT Connection Standard
- * Selected 3" and 5" Dial Thermometers Available from Stock

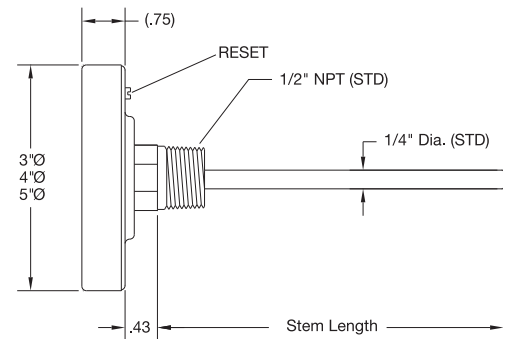

Backmounted Bimetal Dial Thermometers Standard Sizes and Ranges 1/2" NPT Connection Standard

Dial Dia. (in)	Stem Length (in)	Part Number by Temperature Range					
		-40 to 160°F	0 to 100°F	0 to 200°F	0 to 250°F	50 to 300°F	50 to 550°F
3	2.5	BMT10001	BMT10004	BMT10007	BMT10010	BMT10013	BMT10016
	4	BMT10002	BMT10005	BMT10008	BMT10011	BMT10014	BMT10017
	6	BMT10003	BMT10006	BMT10009	BMT10012	BMT10015	BMT10018
5	2.5	BMT10019	BMT10022	BMT10025	BMT10028	BMT10031	BMT10034
	4	BMT10020	BMT10023	BMT10026	BMT10029	BMT10032	BMT10035
	6	BMT10021	BMT10024	BMT10027	BMT10030	BMT10033	BMT10036

Stock Items Are Shown In RED

Adjustable Angle Bimetal Dial Thermometers

Design Features

- * Complete 180° Adjustability
- * 360° Case Rotation
- * All Stainless Steel Construction
- * Hermetically Sealed (ASME B40.3)
- * Accurate to 1% of Full Scale
- * Standard External Reset
- * Silicone Fillable for Vibration Resistance
- * 1/2" NPT Connection Standard
- * Selected 3" and 5" Dial Thermometers Available from Stock

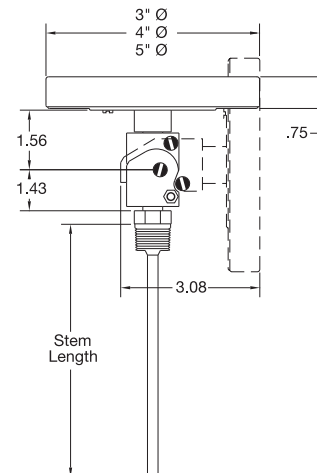

CONTINUED



Bimetal Dial Thermometers for Industrial Applications

Continued from previous page...

Adjustable Angle Bimetal Dial Thermometers Standard Sizes and Ranges 1/2" NPT Connection Standard

Dial Dia. (in)	Stem Length (in)	Part Number by Temperature Range					
		-40 to 160°F	0 to 100°F	0 to 200°F	0 to 250°F	50 to 300°F	50 to 550°F
3	2.5	BMT20001	BMT20004	BMT20007	BMT20010	BMT20013	BMT20016
	4	BMT20002	BMT20005	BMT20008	BMT20011	BMT20014	BMT20017
	6	BMT20003	BMT20006	BMT20009	BMT20012	BMT20015	BMT20018
5	2.5	BMT20019	BMT20022	BMT20025	BMT20028	BMT20031	BMT20034
	4	BMT20020	BMT20023	BMT20026	BMT20029	BMT20032	BMT20035
	6	*BMT20021	BMT20024	BMT20027	BMT20030	BMT20033	BMT20036

Stock Items Are Shown In **RED**

Ordering Code **BMT** -

Dial Diameter BOX 1

Standard: **3** = 3"
5 = 5"
Special: **4** = 4"
9 = Other (Specify)

Temperature Scale BOX 5

Standard: **F** = Fahrenheit
Special: **C** = Celsius
D = Dual

Dial Mounting Style BOX 2

A = Adjustable Angle
B = Back Mounted

Stem Length BOX 3

Whole inches + tenths
Standard Stem Lengths are:
025 = 2.5" **040** = 4" **060** = 6"
090 = 9" **120** = 12"

Note: For special order, lengths from 2.5" (025) to 80" (800) are available;
Consult Tempco with your requirements.

Mounting/Fitting BOX 4

Standard: **1** = 1/2" NPT
Special: **5** = 3/4" NPT adapter
U = 1/2" NPT union (female conversion)
C = 1-1/2" Sanitary Tri-Clamp
L = 2" Sanitary Tri-Clamp
M = 3/4" Sanitary Tri-Clamp

Others available; consult TEMPCO with your requirements.

Temperature Ranges BOX 6

Code	Fahrenheit	Celsius	Dual (°F & °C)
Standard:			
23	-40/160°F		
35	0/100°F		
43	0/200°F		
47	0/250°F		
63	50/300°F		
67	50/500°F		
Special:			
23		-40/70°C	-40/160°F & -40/70°C
55	25/125°F	0/50°C	25/125°F & -5/50°C
43		0/100°C	0/200°F & -10/90°C
47		-20/120°C	0/250°F & -20/120°C
63		10/150°C	50/300°F & 10/150°C
67		10/250°C	50/500°F & 10/250°C
69	50/550°F	10/300°C	50/550°F & 10/300°C
81	150/750°F	50/400°C	150/750°F & 70/400°C
85	200/1000°F	100/500°C	200/1000°F & 100/500°C

Others ranges available; consult Tempco with your requirements.

Special Options BOX 7

PS = Pointed Stem **PC** = Acrylic Window
SF = Silicone Fill **PY** = Polycarbonate Window
SS = 316 SS Stem **TG** = Tempered Glass Window
F3 = 3/8" Stem Diameter **MM** = Min/Max Pointer
Consult Tempco with your requirements.

Ordering Information

Bimetal Thermometers are offered with the options listed in the worksheet above. Create an ordering code by filling in the boxes with the appropriate number and/or letter designation for your requirements and a part number will be assigned. Part Numbers for commonly used Bimetal Thermometers can be found in table above.

Standard lead time is stock to 3 weeks.

⚠ WARNING: Cancer and Reproductive Harm - www.P65Warnings.ca.gov.

(800) 323-6859 • Email: sales@tempco.com

Current Indicators

Current Indicators

Wire-Mounted Current Indicators

Tempco's wire-mounted electrical current indicators provide an effective method of monitoring electrical current. The indicator is attached directly to a current-carrying wire. When the current exceeds the turn-on point, the LED will illuminate to indicate the presence of current.

Red LED Indicator

Part Number: CTT00001

Green LED Indicator

Part Number: CTT00002

Panel Mounting Bracket

Part Number: CTT00003

Wire Passes	Turn-On Point (Amps AC)		Max. Wire Dia. (in.)
	Red LED	Green LED	
1	2	2.5	.29
2	1	1.25	.14
3	.66	.83	.13
N	$2 \div N$	$2.5 \div 2$	-

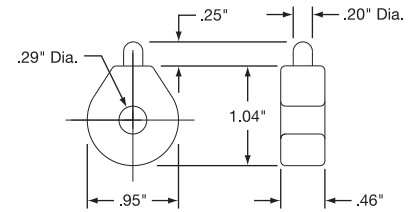
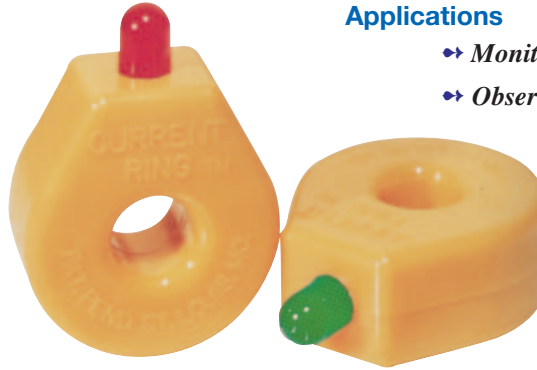

Design Features

- * Self Powered
- * Easy to Install
- * Supplied with Plastic Tie
- * Indicates Current from 2 to 100 Amps AC (1 Wire Pass)

Applications

- ➔ Monitor Heater Element Status
- ➔ Observe Remote Loads

Remote Current Indicators

The Tempco remote current sensing transformer is installed around the current-carrying wire and is connected directly to the LED panel indicator. When the current exceeds the turn-on point of the sensing transformer, the LED illuminates to indicate the presence of current. Two sizes of remote current sensing transformers are available for use with either of two types of LED indicators listed below at right.

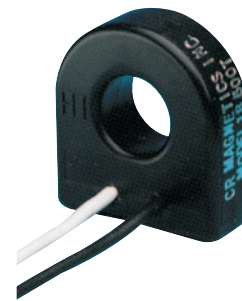

Specifications

Max. Wire Dia.: .29 inches
 Indicating Range: 2 to 100 Amps AC
 Max. Transient Current: 150A for 5 sec.
 Working Class: 600 Volts, 50-60 Hz
 Lead Wire Length: 12"
 Max. Operating Temperature: 140°F/60°C
 Part Number: CTT00004

Specifications

Max. Wire Dia.: .55 inches
 Indicating Range: 2.5 to 100 Amps AC
 Max. Transient Current: 150A for 5 sec.
 Working Class: 600 Volts, 50-60 Hz
 Lead Wire Length: 24"
 Max. Operating Temperature: 140°F/60°C
 Part Number: CTT00005

Typical Applications

- ➔ Indicate Open Heater Elements
- ➔ Observe Remote Loads
- ➔ Indicate Phase Loss
- ➔ Monitor Motor Operation

Surface Mounting Bracket

For use on model CTT00005 only

Dimensions: 1.37" x 1.25"
 Mounting Dims.: (2) #6 screws .87" apart
 Part Number: CTT00006

All Items Available from Stock

Panel LED Indicators for Remote Current Transformers

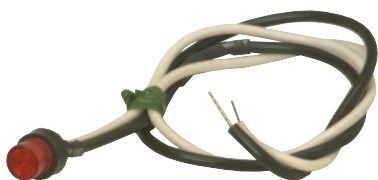

Press-In Panel LED Indicator with 12" leads



Splash-Proof Panel LED Indicator with 12" leads

Press-In LED Panel Indicator

LED Type: T-1-3/4", Red Bipolar
 Mounting Hole: .250"
 Part Number: CTL00001

Splash-Proof LED Indicator

Supplied with rubber sealing washer LED Type: T-1-1/4", Red Bipolar
 Mounting Hole: .312"
 Part Number: CTL00002

Current Sensing Relay for Heater Monitoring

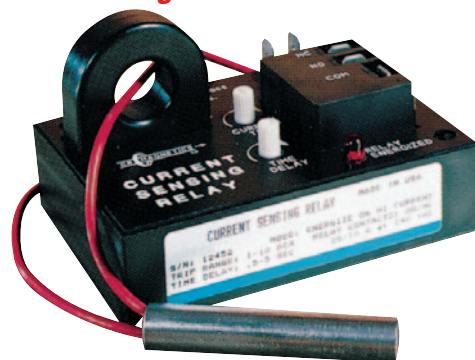
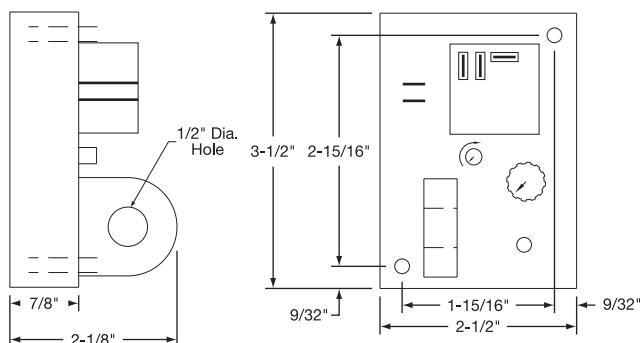

Specifications

Mounting: 2-3/16" dia. clearance holes on 1-15/16" by 2-15/16" centers

Environmental:

Operating Temperature: -30°C to +60°C

Storage Temperature: -55°C to +125°C

Power-On Delay: 100 ms max.

Hysteresis: 5% max.

Input Power Supply: 120 or 240Vac, 24 Vdc (Tolerance ±10%)

Input Terminals: 2-1/4" Male Quick Connect

Operating Class: 600 V

Sensed Current:

Max. Continuous: 200% Full Scale

Frequency: 60-400 Hz

Output Relay:

Arrangement: 1 Form C (SPDT)

Terminals: 3-1/4" Male Quick Connect

Contact Rating: NO-120/240 Vac: 20A, NC-120/240 Vac: 10A

Common Configurations

(with Calibrated Dial & Standard Relay)

Part Number	Trip Status	Supply Voltage	Trip Range (Amps)	Delay (sec)
CTR00201	LC	120	1 to 10	2 to 25
CTR00202	LC-Latch	120	1 to 10	2 to 25
CTR00203	LC	240	3 to 30	2 to 25
CTR00204	LC-Latch	240	3 to 30	2 to 25
CTR00205	LC	240	10 to 100	2 to 25
CTR00206	LC-Latch	240	10 to 100	2 to 25

The TEMPCO series of **Current Sensing Relays** provides an effective and highly stable method for monitoring electrical current. The current-carrying wire is routed through the opening extending from the top of the case. When current reaches the level set by the trip point adjustment, the electromechanical relay is energized. An adjustable timer is provided to delay activation of the relay. A precision voltage reference circuit ensures a highly repeatable trip point. Design of the power-on delay circuitry allows the supply power to be repeatedly cycled on and off without affecting the stability of the current sensing operation.

Design Features

- * Variable Trip Point and Time Delay
- * Monitors Currents from 10 mA to 100 AC Amps
- * Output Relay Rated Up to 20 Amps
- * LED Relay Status Indicator
- * Dead Band Prevents Relay Chatter
- * Calibrated Dial
- * Electrical Isolation Between Circuits

Typical Applications

- Monitor Electrical Heater Elements
- Sense Motor Over/Under Loads
- Detect Lamp Burnout
- Indicate Phase Loss

Ordering Code: CTR - 1 2 3 4 5 6

Relay Trip Status BOX 1

- 1** = Relay Energized on High Current (above trip point)
- 2** = Relay Energized on Low Current (below trip point)
- 3** = Latch on High Current
- 4** = Latch on Low Current

NOTE: For 3 and 4 relay remains latched until supply power is removed

Supply Voltage BOX 2

- 1** = 120 Vac
- 2** = 240 Vac
- 3** = 24 Vdc

Trip Ranges BOX 3

- 3** = 1.0 to 10 AC Amps
- 4** = 3.0 to 30 AC Amps
- 5** = 6.0 to 60 AC Amps
- 6** = 10 to 100 AC Amps

Time-On Delay BOX 4

- A** = .5 to 6 Sec.
- B** = 2 to 25 Sec.
- C** = .1 to 1 Sec.
- X** = None

Trip Point Dial BOX 5

- CD** = Calibrated Dial
- FP** = Fixed Setpoint (specify required value)

Output Options BOX 6

- R** = Standard Relay
- N** = Isolated NPN Transistor
- T** = Isolated Triac

Ordering Information

Current Relays are offered with the options listed in the worksheet above. Create an ordering code by filling in the boxes with the appropriate number and/or letter designation for your requirements and a part number will be assigned, or choose a common configuration. **Standard lead time is stock to 3 weeks.**

⚠ WARNING: Cancer and Reproductive Harm - www.P65Warnings.ca.gov.

Digital Multimeter — For Volts, Amps, Ohms and Temperature



Design Features

- * True RMS Autoranging DMM
- * Type K thermocouple built in for air or water temperature measurements
- * Input fuse protection and misconnection warnings
- * Data Hold for AC/DC voltage and current
- * Relative function for establishing a baseline reference
- * Advanced measurements include Capacitance, Frequency and Duty Cycle
- * Low current capability — measure down to 0.1μA
- * CE, UL, CAT III – 600V
- * 3-year warranty

Specifications

Display: 4000 counts, backlit	Resistance: 0.1 to 40MΩ
Basic Accuracy: ±0.3%	Capacitance: 0.01nF to 100μF
DC Voltage: 0.1mV to 1000V	Frequency: 0.001Hz to 10MHz
AC Voltage: 0.1mV to 750V	Temperature Type K: -4° to 1382°F (-20 to 750°C)
DC Current: 0.1μV to 20A	Duty Cycle: 0.1 to 99.9%
AC Current: 0.1μV to 20A	Diode/Continuity: Yes

Part Number: EMV00018

Complete with CAT III test leads, multi-position tilt stand and velcro strip for hanging, protective holster with test lead holder, bead wire temperature probe and 9 Vdc battery.

All Items Available from Stock

400 Amp Clamp-On Multimeter with Temperature and Non-Contact Voltage Detector



Design Features

- * Built-in Non-Contact Voltage Detector with LED alert
- * 4000 count, backlit LCD display
- * 1.2" jaw size for conductors up to 350MCM
- * Relative Mode for Capacitance Zero and Offset Adjustment
- * Data Hold
- * Auto Power Off
- * Complete with test leads, general purpose Type K bead wire temperature probe, two AAA batteries, and carrying case

Specifications	Range	Maximum Resolution	Basic Accuracy
Display Counts:	4000		
AC Current:	40.00A, 400.0A	0.01A	±(2.5%+8d)
AC Voltage:	4.00V, 40.00V, 400.0V, 600V, 400.0mV, 4.000V, 40.00V, 400.0V	0.001V	±(1.8%+8d)
DC Voltage:	600V	0.1mV	±(0.8% +2d)
Resistance:	400.0Ω, 4.000kΩ, 40.00kΩ, 400.0kΩ, 4.000MΩ, 40.00MΩ	0.1Ω	±(0.8% +2d)
Frequency:	10Hz to 10kHz	0.01Hz	±(1.5%+2d)
Capacitance:	40.00nF, 400.0nF, 40.00uF, 100.0uF	0.01nF	±(3.0%+5d)
Temperature:	Type K tc, -4° to 1400°F (-20° to 760°C)	0.1°	±(3.0%+9°F or 5°C)
Duty Cycle:	0.5 to 99.0%	0.1%	±(1.2%+2d)
Diode Test:	Yes		
Continuity Test:	Yes		
Dimensions:	7.9" × 2.6" × 1.5" (200 × 66 × 37 mm)		
Weight:	7.2oz. (205g)		

Part Number: EMV00060

The EMV00060 is the perfect meter for plant maintenance or HVAC repair. Besides the standard voltage current and resistance, the additional functions of temperature, capacitance, frequency and duty cycle make this the perfect all-in-one service tool.

Megohmmeter/ Insulation Tester

Design Features:

- * Three test ranges:
200M Ω /1000VDC
200M Ω /500VDC
200M Ω /250VDC
- * Power lock for 3-minute test
- * Auto power off and Data Hold
- * No voltage drop at low resistance
- * Full function indication and Overload Protection
- * Measures resistance to 200 Ω and Volts to 750VAC
- * 1mA test current ensures 1000V/500V/250V rating
- * Complete with 6 AA batteries, test leads and case with neck strap

Part Number: EMM00010

Specifications	Range
Insulation Voltage:	250/500/1000
Insulation Resistance (accuracy):	200/2000M Ω (3% + 5 digits)
Output short circuit current:	\leq 2.5mA
Resistance (accuracy):	200 Ω (1% reading)
Overload Protection:	2200 V (<1 min)
Dimensions:	3.8" \times 6.3" \times 2.3" (97 \times 160 \times 58mm)



All Items Available from Stock

Digital Thermometers

Handheld Digital Thermometers — Heavy Duty, Accurate

Type J or K Thermometers with single or dual input, with direct or differential measurements to 0.1°

Design Features:

- * Rugged design for field use — includes rubber holster.
- * Displays Maximum reading and Data Hold at the touch of a button.
- * Single or dual input models available.
- * Dual input model provides differential readings.
- * Accurate to 0.3%, °F/°C switchable on the front panel.
- * Includes: 9V battery, holster with stand, wrist strap and bead-style temperature probe.

All Items Available from Stock



DTM11010



DTM11020



DTM11030

Specifications

	DTM11010	DTM11020	DTM11030
Thermocouple:	Single Type K	Dual Type K	Dual Type J or K
Temperature Range:	-58° to 2000°F (-50° to 1300°C)		J -328° to 1922°F (-200° to 1050°C) K -328° to 2498°F (-200° to 1370°C)
Basic Accuracy:	± 0.3% of reading		± 0.05% of reading
Display Counts:	2000		20,000
Resolution:	0.1° / 1°		0.2°F / 0.1°C
Dimensions:	6.5" × 3" × 1.7" (165 × 76 × 43mm)		7.6" × 3.6" × 2.1" (192 × 91 × 53mm)
Weight:	14.2 oz (403g)		13 oz (365g)

Temperature Probes – Thermocouple Type K

All probes shown come with 39" of cable and a mini-type plug.

DTA11015

- * Surface Probe
- * Straight Shaft
- * 6" (152 mm) long Ceramic Tip
- * Maximum Temperature: 932°F / 500°C



DTA11025

- * Blunt-end Probe
- * 4" (102 mm) long, 0.130" dia. rounded tip
- * Type K T/C
- * Maximum Temperature: 1292°F / 700°C



DTA11035

- * Piercing-end Probe
- * 4" (102 mm) long, 0.130" dia. rounded tip
- * Type K T/C
- * Maximum Temperature: 1472°F / 800°C





Table Of Contents

Pictorial Index	A-32	Infinite Heat Switch	13-51
DIN Controllers with LCD Display	13-1A	Power Control Consoles & Panels	13-52
1/32 DIN Digital Temperature Controls	13-4	PCT Series Thermostat & Temp. Controls	13-54
1/16 DIN Digital Temperature Controls	13-8	PCM-1000 Series Power Control Boxes	13-55
High Limit Temp. Controls	13-16	Power Control Panels	13-56
Ramp & Soak Temp. Controls	13-18	MX Hot Runner Temp. Controls	13-64
1/16 DIN Display Only	13-20	Solid State Variable Power Controllers	13-67
1/16 DIN Single Display Control with Pushwheel Setpoint	13-20	Electronic Contract Manufacturing	13-68
1/16 DIN Analog Temp. Controls	13-22	SCR Power Controllers	13-71
1/8 DIN Digital Temp. Controls	13-24	Thermostats:	
1/8 DIN Analog Temp. Control	13-28	Bulb and Capillary	13-76
3/16 DIN Digital Temp. Control	13-30	Conduction Type Surface Mount	13-81
3/16 DIN Analog Temp. Control	13-32	1/2" Snap Action & High Limit	13-82
1/4 DIN Digital Temp. Controls	13-34	Thermal Cutoffs / Fuses	13-84
1/4 DIN Analog Temp. Controls	13-38	Thermostats – Cartridge Type	13-85
TBC Board PID Control	13-42	Solid State Relays & Heatsinks	13-88
Digital Control Features	13-46	Mercury Relays	13-92
Control Accessory Items	13-47	Mechanical Relays – DIN Rail Mount	13-95
Encapsulated Temp. Control	13-50	Enclosed IEC Style Contactors	13-96

13
section

3/16 DIN Digital Control



TEC-7400

- * LCD Display
 - * 2 Programmable Outputs
 - * 1 Alarm
 - * Ramp & Soak
 - * Heater Break Alarm
- See Page 13-3G



1/4 DIN Digital Control

TEC-4400

- * LCD Display
 - * 2 Programmable Outputs
 - * 3 Alarms
 - * Ramp & Soak
 - * Heater Break Alarm
- See Page 13-3I

DIN Rail Mount Digital Control



TEC-6400

- * LCD Display
 - * 3 Programmable Outputs
 - * Ramp & Soak
 - * Heater Break Alarm
- See Page 13-3K

Learn about our

Competitive Pricing!

Contact us today.

Pictorial Index of DIN Controllers

1/32 DIN Digital Controls



TEC-220

- * NEMA 4X Front
- * 3 Programmable Outputs
- See Page 13-4



TEC-2500

- * NEMA 4X Front
- * 4 Programmable Outputs
- * Heater Break Alarm
- See Page 13-6

1/16 DIN Digital Controls



TEC-920

- * Low Cost
- * Single Display
- * 2 Programmable Outputs
- See Page 13-8



TEC-9100

- * 4 Programmable Outputs
- * Dual Display
- * Cutting Edge Technology
- See Page 13-10



TEC-9090

- * 2 Programmable Outputs
- * Dual Display
- See Page 13-12



TEC-9300

- * 4 Programmable Outputs
- * Heater Break Alarm
- * NEMA 4X Front
- See Page 13-14

3/16 DIN Digital Controls



TEC-7100

- * 4 Programmable Outputs
- * Compact Size
- See Page 13-30



TEC-704

- * Process Digital Display
- * Potentiometer Setpoint
- See Page 13-32

1/8 DIN Digital Controls



TEC-8100

- * 4 Programmable Outputs
- * NEMA 4X Front Optional
- * Cutting Edge Technology
- See Page 13-24



TEC-8300

- * 5 Programmable Outputs
- * Heater Break Alarm
- * Differential Control
- * Loop Break Alarm
- * Analog Input
- * Event Input
- * Retransmission Output
- See Page 13-26

1/4 DIN Digital Controls



TEC-4100

- * 4 Programmable Outputs
- * NEMA 4X Front Optional
- * Retransmission Output
- See Page 13-34



TEC-4300

- * 5 Programmable Outputs
- * Heater Break Alarm
- * Differential Control
- * Loop Break Alarm
- * Analog Input
- * Event Input
- * Retransmission Output
- See Page 13-36

Ramp & Soak Controls



TEC-4500 1/4 DIN

TEC-9500 1/16 DIN

- * 9 Recipes
- * 16, 32 or 64 Segments per Recipe
- See Page 13-18

1/16 DIN Analog Controls



TEC-901
 * Non-Indicating
 * Potentiometer Setpoint
 See Page 13-22



TEC-902
 * With High /Low LEDs
 * Potentiometer Setpoint
 See Page 13-22



TEC-905
 * Pushwheel Setpoint
 * Process Digital Display
 See Page 13-20

1/8 DIN Analog Control



TEC-805
 * Primary Output
 * Deviation Alarm Optional
 * Multiple Ranges Available
 * Process Digital Display
 * Pushwheel Setpoint
 See Page 13-28

1/16 DIN Display Only



TEC-900
 * Display Only
 * T/C or RTD Inputs
 * High or Low Voltage Operation
 See Page 13-20

1/4 DIN Analog Controls



TEC-401
 * Non-Indicating
 * Potentiometer Setpoint
 * Low Cost
 See Page 13-40



TEC-402
 * Process Deviation Meter
 * Potentiometer Setpoint
 * Low Cost
 See Page 13-40



TEC-404
 * Potentiometer Setpoint
 * Process Digital Display
 * Deviation Alarm Optional
 See Page 13-38



TEC-405
 * Pushwheel Setpoint
 * Process Digital Display
 * Deviation Alarm Optional
 See Page 13-38

FM High Limit Controls



TEC-410 1/4 DIN
TEC-910 1/16 DIN
 * High Limit Control
 * External Reset Standard
 * Retransmission Optional
 * Latching Relay
 See Page 13-16

Temperature Controllers



Model TEC-2400 1/32 DIN

Model TEC-2400 1/32 DIN Temperature Controller



Design Features

- * 1/32 DIN size – 24 mm × 48 mm
- * Fuzzy Logic PID Autotune heat and cool control
- * Universal input, field configurable (Type J T/C default, PT100, mA, V) with high accuracy 18-bit D-A
- * Countdown display
- * RS - 485 and Analog Retransmission Available
- * Micro USB Programming Port
- * Fast sampling rate (200 msec)
- * Manual control & auto-tune function
- * Wide range of alarm mode selection
- * Lockout protection
- * Bumpless transfer during failure mode
- * Soft-start ramp & dwell timer
- * Bright LCD display using NFPA/IEC standard colors
- * High performance with low cost

Agency Approvals:



RoHS, REACH, WEEE

Hardware Code: TEC-2400 - 1 2 3 4 5

A Part Number based on the hardware code and any software pre-programming will be issued at time of order.

Standard lead time is stock to 2 weeks.

Power Input BOX 1

- 4** = 90-250 VAC
- 5** = 11-40 VDC / 20-28 VAC

Output 1 — BOX 2

- 1** = Relay: 2A / 240 VAC
- 2** = Pulse DC for SSR drive: 5 VDC (30 mA max)
- 3** = Isolated, 4-20 mA (default), 0-20 mA
- 5** = Isolated VDC, 0-10 scalable
- C** = Pulse DC for SSR drive: 14 VDC (40mA max)

Output 2 / Alarm 1 BOX 3

- 0** = None
- 1** = Relay: 2A / 240 VAC
- 2** = Pulse DC for SSR drive: 5 VDC (30 mA max)
- 3** = Isolated, 4-20 mA (default), 0-20 mA
- 5** = Isolated, VDC, 0-10 scalable
- C** = Pulse DC for SSR drive: 14 VDC (40mA max)

Option 1 BOX 4

- 0** = None
- 1** = RS-485 Interface
- 2** = 1 Event Input
- 3** = 1 CT Input

Option 2 BOX 5

- 0** = None
- 1** = Retransmit: 4-20mA / 0-20mA
- 2** = Retransmit: 0-10VDC
- 3** = Alarm 2 Relay: 2A / 240 VAC



Note: Detailed information on features common to digital microprocessor-based TEC temperature controls and the complete Table of Input Range and Accuracy can be found on page 13-46.

Transformer for Heater Break Alarm

(0-50 Amp current)

Part Number: TEC99998

Specifications on page 13-47



Power Input

Standard: 90-250 VAC, 47-63 Hz, 8VA, 4W maximum
Optional: 11-40 VDC / 20-28 VAC, 47-63 Hz, 8VA, 4W maximum

Signal Input

Resolution: 18 Bits
Sampling Rate: 5 Times / Second (200msec)
Maximum Rating: -2VDC minimum, 12VDC maximum
Sensor Break Detection: Sensor open for Thermocouple and RTD inputs, sensor short for RTD input, below 1mA for 4-20mA input, below 0.25V for 1 - 5V input, not available for other inputs
Sensor break responding time: Within 4 seconds for thermocouple and RTD inputs, 0.1 second for 4-20mA and 1-5V inputs

Event Input

Number of Event Inputs: 1
Logic Low: -10V minimum, 0.8V maximum
Logic High: 2V minimum, 10V maximum

CT Input

CT type: TEC99998
Accuracy: $\pm 2\%$ of full scale reading, ± 1 digit maximum
Input Impedance: 294 Ω
Measurement Range: 0-50A AC
Output of CT: 0-5V DC
CT Mounting: Wall (Screw) mount
Sampling Rate: 1 time/second

Output 1 / Output 2

Type: Relay, pulsed voltage, linear voltage and linear current
Relay Rating: 2A, 240V AC, 200000 life cycles for resistive load
Pulsed Voltage: Source voltage 5V, Current limiting resistance 66 Ω
Linear Output Resolution: 15 Bits
Isolation Breakdown Voltage: 1000 V AC
Load Capacity of Linear Output: Linear current: 500 Ω maximum, Linear voltage: 10K Ω minimum

Alarm

Relay Type: Form A
Maximum Rating: 2A, 240VAC, 200000 life cycles for resistive load
Alarm Functions: Dwell Timer, Deviation Low, Deviation High, Deviation Band Low, Deviation Band High, Process High, Process Low
Alarm Mode: Latching, Hold, Normal, Latching/Hold
Dwell Timer: 0.1-4553.6 minutes

Data Communications

Interface: RS-485
Address: 1-247
Parity Bit: None, Even or Odd
Data Length: 7 or 8 Bits
Protocol: Modbus RTU
Baud Rate: 2.8 - 115.2 Kbits/sec
Stop Bit: 1 or 2 Bits
Communication Buffer: 160 bytes

Analog Retransmission

Output Signal: 4-20 mA, 0-20 mA, 0-10V
Resolution: 15 Bits
Accuracy: $\pm 0.05\%$ of span $\pm 0.0025\%$ / $^{\circ}\text{C}$
Load Resistance: 0-500 Ω for current output, 10K Ω minimum for voltage output
Isolation Breakdown: 1000VAC minimum
Integral Linearity Error: $\pm 0.005\%$ of span
Linear Output Ranges: 0-22.2mA (0-20mA / 4-20mA), 0-5.55V (0-5V, 1-5V), 0-11.1V (0-10V)

User Interface

Keypad: 4 Keys
Display Type: 4 digit LCD display
No. of Display: 2
Upper Display Size: 0.4" (10mm)
Lower Display Size: 0.19" (4.8mm)

Programming Port

Interface: Micro USB
PC Communication Function: Automatic Setup, Calibration and Firmware Upgrade

Control Mode

Output 1: Reverse (Heating) or Direct (Cooling) Action
Output 2: PID cooling control, Cooling P band 50~300% of PB, Dead band -36.0 ~ 36.0 % of PB
ON-OFF: 0.1-90.0 ($^{\circ}\text{F}$) hysteresis control (P band = 0)
P or PD: 0-100.0 % offset adjustment
PID: Fuzzy logic modified Proportional band 0.1 ~ 900.0 $^{\circ}\text{F}$, Integral time 0~3600 seconds, Derivative time 0-360.0 seconds
Cycle Time: 0.1-90.0 seconds
Manual Control: Heat (MV1) and Cool (MV2)
Failure Mode: Auto transfer to manual mode while sensor break or A-D Converter damage
Ramping control: 0 to 900.0 $^{\circ}\text{F}$ / Minute or 0 to 900.0 $^{\circ}\text{F}$ / Hour Ramp Rate

Environmental and Physical Specifications

Operating Temperature: -10 $^{\circ}\text{C}$ to 50 $^{\circ}\text{C}$
Storage Temperature: -40 $^{\circ}\text{C}$ to 60 $^{\circ}\text{C}$
Humidity: 0 to 90 % RH (Non-Condensing)
Insulation Resistance: 20M Ω minimum (@500V DC)
Dielectric Strength: 2000V AC, 50/60 Hz for 1 Minute
Vibration Resistance: 10 to 55 Hz, 10m/s² for 2 Hours
Shock Resistance: 200 m / s² (20g)
Moldings: Flame retardant polycarbonate
Mounting: Panel
Dimensions W x H x D: 15/16 x 1-7/8 x 3-13/16" (48 x 24 x 92 mm)
Depth Behind Panel: 3-15/16" (84 mm)
Cut Out Dimensions: 7/8 x 1-25/32" (22 x 45 mm)
Weight: .26 lbs (160 g)

Rear Terminal Connections

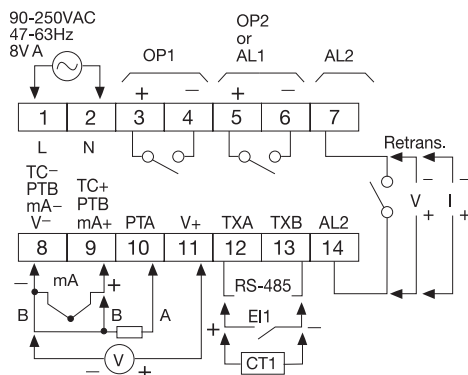

Stock and Common Part Numbers

(Default Type "J" Thermocouple Input)

Part Number	Output 1	Out 2/ Alm 1	Option 1
TEC04001	Relay	None	None
TEC04002	Relay	Relay	None
TEC04003	Relay	Relay	Event Input
TEC04004	Pulse DC	None	None
TEC04005	Pulse DC	Relay	None
TEC04006	Pulse DC	Relay	Event Input
TEC04007	4-20mA	None	None
TEC04008	4-20mA	Relay	Event Input

Model TEC-9400 1/16 DIN Temperature Controller



Design Features

- * 1/16 DIN size – 48 mm × 48 mm
- * Fuzzy Logic PID Autotune heat and cool control
- * Universal input, field configurable (Type J T/C default, PT100, mA, V) with high accuracy 18-bit D-A
- * Countdown display
- * RS - 485 and Analog Retransmission Available
- * Micro USB Programming Port
- * Fast sampling rate (200 msec)
- * Manual control & auto-tune function
- * Wide range of alarm mode selection
- * Lockout protection
- * Bumpless transfer during failure mode
- * Soft-start ramp & dwell timer
- * Bright LCD display using NFPA/IEC standard colors
- * High performance with low cost

Agency Approvals:



RoHS, REACH, WEEE

Hardware Code: TEC-9400 -

A Part Number based on the hardware code and any software pre-programming will be issued at time of order.

Standard lead time is stock to 2 weeks.

Power Input BOX 1

- 4 = 90-250 VAC
- 5 = 11-40 VDC / 20-28 VAC

Output 1 BOX 2

- 1 = Relay: 2A / 240 VAC
- 2 = Pulse DC for SSR drive: 5 VDC (30 mA max)
- 3 = Isolated, 4-20 mA (default), 0-20 mA
- 5 = Isolated VDC, 0-10 scalable
- C = Pulse DC for SSR drive: 14 VDC (40 mA max)

Output 2 / Alarm 1 BOX 3

- 0 = None
- 1 = Relay: 2A / 240 VAC
- 2 = Pulse DC for SSR drive: 5 VDC (30 mA max)
- 3 = Isolated, 4-20 mA (default), 0-20 mA
- 5 = Isolated, VDC, 0-10 scalable
- C = Pulse DC for SSR drive: 14 VDC (40 mA max)

Alarm 2 BOX 4

- 0 = None
- 1 = Relay: 2A / 240 VAC

Option 1 BOX 5

- 0 = None
- 1 = RS-485 Interface

Option 2 BOX 6

- 0 = None
- 1 = 2 Event Inputs
- 2 = 1 Event Input and 1 CT Input
- 3 = 2 CT Inputs

Option 3 BOX 7

- 0 = None
- 1 = Retransmit: 4-20 mA / 0-20 mA
- 2 = Retransmit: 0-10 VDC
- 3 = Relay: 2A / 240 VAC

Option 4 BOX 8

- 0 = None
- 1 = Terminal Cover



Note: Detailed information on features common to digital microprocessor-based TEC temperature controls and the complete Table of Input Range and Accuracy can be found on page 13-46.

Transformer for Heater Break Alarm

(0-50 Amp current)

Part Number: TEC99998

Specifications on page 13-47



Power Input

Standard: 90-250 VAC, 47-63 Hz; 10 VA, 5W max.
Optional: 11-40 VDC / 20 to 28 VAC, 47-63 Hz; 10 VA, 5W max.

Signal Input

Resolution: 18 bits
Sampling Rate: 5 Times / Second (200msec)
Maximum Rating: -2VDC minimum, 12VDC maximum
Sensor Break Detection: Sensor open for Thermocouple and RTD inputs, sensor short for RTD input, below 1mA for 4-20mA input, below 0.25V for 1-5V input, not available for other inputs
Sensor Break Response Time: Within 4 seconds for Thermocouple and RTD inputs, 0.1 second for 4-20mA and 1-5V inputs

Event Input

Number of Event Inputs: 2
Logic Low: -10V minimum, 0.8V maximum
Logic High: 2V minimum, 10V maximum

CT Input

CT Type: TEC99998
Accuracy: ±2% of Full Scale Reading, ± 1 digit maximum
Input Impedance: 294Ω
Measurement Range: 0-50A AC
Output of CT: 0-5V DC
CT Mounting: Wall (Screw) Mount
Sampling Rate: 1 Time/Second

Output 1 / Output 2

Relay Rating: 2A, 240V AC, 200000 Life Cycles for Resistive Load
Pulsed Voltage: Source Voltage 5V, Current Limiting Resistance 66Ω
Linear Output Resolution: 15 Bits
Isolation Breakdown Voltage: 1000 V AC
Load Capacity of Linear Output: Linear Current: 500Ω maximum, Linear Voltage: 10KΩ minimum

Alarm

Maximum Rating: 2A, 240VAC, 200000 Life cycles for resistive load
Alarm Functions: Dwell Timer, Deviation Low, Deviation High, Deviation Band Low, Deviation Band High, Process High, Process Low
Alarm Mode: Latching, Hold, Normal, Latching/Hold
Dwell Timer: 0.1 to 4553.6 Minutes

Data Communications

Interface: RS-485
Address: 1-247
Parity Bit: None, Even or Odd
Data Length: 7 or 8 Bits
Protocol: Modbus RTU
Baud Rate: 2.8 - 115.2 Kbits/sec
Stop Bit: 1 or 2 Bits
Communication Buffer: 160 bytes

Analog Retransmission

Output Signal: 4-20 mA, 0-20 mA, 0-10V
Resolution: 15 Bits
Accuracy: ±0.05% of span ± 0.0025% / °C
Load Resistance: 0-500Ω for current output, 10KΩ minimum for voltage output
Isolation Breakdown: 1000VAC minimum
Integral Linearity Error: ±0.005% of span
Linear Output Ranges: 0-22.2mA (0-20mA / 4-20mA), 0-5.55V (0-5V, 1-5V), 0-11.1V (0-10V)

User Interface

Keypad: 4 Keys
Display Type: 4 digit LCD display
No. of Display: 2
Upper Display Size: 0.58" (15mm)
Lower Display Size: 0.3" (7.8mm)

Programming Port

Interface: Micro USB
PC Communication Function: Automatic Setup, Calibration and Firmware Upgrade

Control Mode

Output 1: Reverse (Heating) or Direct (Cooling) Action
Output 2: PID cooling control, Cooling P band 50~300% of PB, Dead band -36.0 ~ 36.0 % of PB
ON-OFF: 0.1-90.0 (°F) hysteresis control (P band = 0)
P or PD: 0-100.0 % offset adjustment
PID: Fuzzy logic modified Proportional band 0.1 ~ 900.0°F, Integral time 0~3600 seconds, Derivative time 0-360.0 seconds
Cycle Time: 0.1-90.0 seconds
Manual Control: Heat (MV1) and Cool (MV2)
Failure Mode: Auto transfer to manual mode while sensor break or A-D Converter damage
Ramping Control: 0 to 900.0°F / Minute or 0 to 900.0°F / Hour Ramp Rate

Environmental and Physical Specifications

Operating Temperature: -10°C to 50°C
Storage Temperature: -40°C to 60°C
Humidity: 0 to 90 % RH (Non-Condensing)
Insulation Resistance: 20MΩ minimum (@500V DC)
Dielectric Strength: 2000V AC, 50/60 Hz for 1 Minute
Vibration Resistance: 10 to 55 Hz, 10m/s² for 2 Hours
Shock Resistance: 200 m / s² (20g)
Moldings: Flame retardant polycarbonate
Mounting: Panel
Dimensions H x W x D: 1-7/8 x 1-7/8 x 2-3/8" (48 x 48 x 59 mm)
Depth Behind Panel: 2" (50 mm)
Cut Out Dimensions: 1-25/32 x 1-25/32" (45 x 45 mm)
Weight: .35 lbs. (160 g)

Stock and Common Part Numbers

(All Stock Part Numbers Include Terminal Covers)
 (Default Type "J" Thermocouple Input)

Part Number	Output 1	Out 2/ Alm 1	Option 1
TEC19001	Relay	None	None
TEC19002	Relay	Relay	None
TEC19003	Relay	Relay	Relay
TEC19004	Pulse DC	None	None
TEC19005	Pulse DC	Relay	None
TEC19006	Pulse DC	Relay	Relay
TEC19007	4-20mA	None	None
TEC19008	4-20mA	Relay	Relay

Rear Terminal Connections

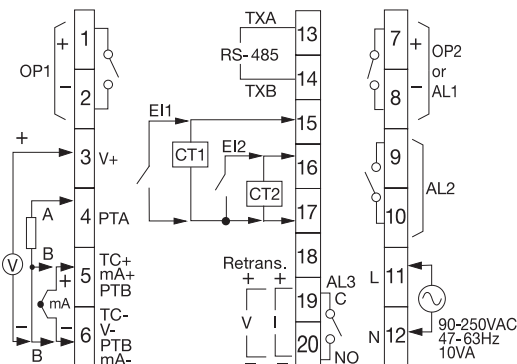

Temperature Controllers

Model TEC-8400 & -8450 1/8 DIN



Model TEC-8400 & Model TEC-8450 1/8 DIN Temperature Controllers

Agency Approvals:



RoHS, REACH, WEEE



Design Features

- * 1/8 DIN size – 48 mm × 96 mm, horizontal: 96 mm × 48 mm
- * Fuzzy Logic PID Autotune heat and cool control
- * Universal input, field configurable (Type J T/C default, PT100, mA, V) with high accuracy 18-bit D-A
- * Countdown display
- * RS - 485 and Analog Retransmission Available
- * Micro USB Programming Port
- * Fast sampling rate (200 msec)
- * Manual control & auto-tune function
- * Wide range of alarm mode selection
- * Lockout protection
- * Bumpless transfer during failure mode
- * Soft-start ramp & dwell timer
- * Bright LCD display using NFPA/IEC standard colors
- * High performance with low cost

Hardware Code:



A Part Number based on the hardware code and any software pre-programming will be issued at time of order.

Standard lead time is stock to 2 weeks.

Power Input BOX 1

- 4 = 90-250 VAC
- 5 = 11-40 VDC / 20-28 VAC

Output 1 BOX 2

- 1 = Relay: 2A / 240 VAC
- 2 = Pulse DC for SSR drive: 5 VDC (30 mA max)
- 3 = Isolated, 4-20 mA (default), 0-20 mA
- 5 = Isolated VDC, 0-10 scalable
- C = Pulse DC for SSR drive: 14 VDC (40 mA max)

Output 2 / Alarm 1 BOX 3

- 0 = None
- 1 = Relay: 2A / 240 VAC
- 2 = Pulse DC for SSR drive: 5 VDC (30 mA max)
- 3 = Isolated, 4-20 mA (default), 0-20 mA
- 5 = Isolated, VDC, 0-10 scalable
- C = Pulse DC for SSR drive: 14 VDC (40 mA max)

Alarm 2 and 3 BOX 4

- 0 = None
- 1 = Alarm 2: Relay: 2A / 240 VAC
- 2 = Alarm 2 & 3: Relays: 2A / 240 VAC

Event Inputs BOX 5

- 0 = None
- 1 = 6 Event Inputs



Note: Detailed information on features common to digital microprocessor-based TEC temperature controls and the complete Table of Input Range and Accuracy can be found on page 13-46.

Option 1 BOX 6

- 0 = None
- 1 = RS-485 Interface & Remote Setpoint

Option 2 BOX 7

- 0 = None
- 1 = 1 CT Input & Remote Setpoint
- 2 = 2 CT Inputs & Remote Setpoint

Option 3 BOX 8

- 0 = None
- 1 = Retransmit: 4-20 mA / 0-20 mA & Remote Setpoint
- 2 = Retransmit: 0-10 VDC & Remote Setpoint
- 3 = Alarm 4 Relay: 2A / 240 VAC & Remote Setpoint
- 4 = Alarm 4 Relay: 2A / 240 VAC, Retransmit: 4-20 mA / 0-20 mA & Remote Setpoint
- 5 = Alarm 4 Relay: 2A / 240 VAC, Retransmit: 0-10 VDC & Remote Setpoint

Option 4 BOX 9

- 0 = None
- 1 = Terminal Covers
- 2 = 2 Programs each with 8 Segments of Ramp & Soak
- 3 = Terminal Covers and Ramp & Soak Firmware

Transformer for Heater Break Alarm

(0-50 Amp current)

Part Number: TEC99998

Specifications on page 13-47

TEC-8400 Rear Terminal Connections

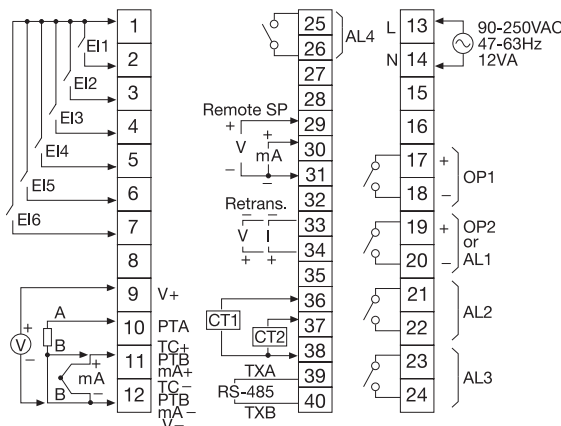

TEC-8450 Rear Terminal Connections

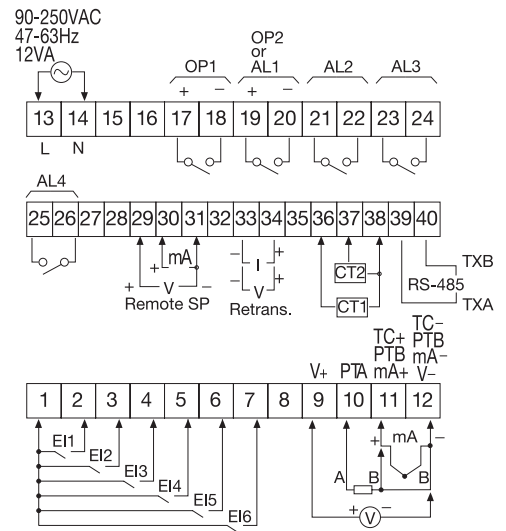



Power Input

Standard: 90-250 VAC, 47-63 Hz, 8VA, 4W maximum
Optional: 11-40 VDC / 20-8 VAC, 47-63 Hz, 10VA, 5W maximum
 or 12VA, 6W maximum

Signal Input

Resolution: 18 Bits **Sampling Rate:** 5 Times/Sec. (200msec)
Maximum Rating: -2VDC minimum, 12VDC maximum
Normal Mode Rejection Ratio (NMRR): 55dB
Sensor Break Detection: Sensor open for thermocouple and RTD inputs, sensor short for RTD input, below 1mA for 4-20mA input, below 0.25V for 1-5V input, not available for other inputs
Sensor Break Responding Time: Within 4 seconds for thermocouple and RTD inputs, 0.1 second for 4-20mA and 1-5V inputs

Remote Set Point Input

Type: Linear current, Linear voltage **Range:** -3-27mA, -1.3-11.5V
Accuracy: ±0.05 % **Input Impedance:** Current: 2.5Ω, Voltage: 1.5MΩ
Resolution: 18 bits **Sampling Rate:** 1.66 times/second
Maximum Rating: 280mA maximum for current input, 12VDC maximum for voltage input
Temperature Effect: ±1.5μV / °C for voltage input, ±3.0μV / °C for current input
Sensor Break Detection: Below 1mA for 4-20mA input, below 0.25V for 1-5V input, not available for other inputs

Event Input

No. of Event Inputs: 6 **Logic Low:** -10Vmin., 0.8V max.
Logic High: 2V min., 10V max.

CT Input

CT Type: TEC99998
Accuracy: ±2% of full scale reading, ± 1 digit max.
Input Impedance: 294Ω **Measurement Range:** 0-50A AC
Output of CT: 0-5V DC **CT Mount:** Wall (Screw) mount
Sampling Rate: 1 time/second

Output 1 / Output 2

Type: Relay, pulsed voltage, linear voltage and linear current
Relay Rating: 2A, 240V AC, 200000 life cycles for resistive load
Pulsed Voltage: Source voltage 5V, Current limiting resistance 66Ω
Linear Output Resolution: 15 Bits
Isolation Breakdown Voltage: 1000 VAC
Load Capacity of Linear Output: Linear current: 500Ω maximum, Linear voltage: 10KΩ minimum

Alarm

Relay Type: Form A
Maximum Rating: 2A, 240VAC, 200000 life cycles for resistive load
Alarm Functions: Dwell timer, Deviation low, Deviation high, Deviation band low, Deviation band high, Process high, Process low
Alarm Mode: Latching, Hold, Normal, Latching/Hold
Dwell Timer: 0.1-4553.6 minutes

Data Communication

Interface: RS-485 **Protocol:** Modbus RTU
Address: 1-247 **Baudrate:** 2.8-115.2 KBPS
Parity Bit: None, Even or Odd **Stop Bit:** 1 or 2 bits
Data Length: 7 or 8 bits **Communication Buffer:** 160 bytes

Stock and Common Part Numbers (8400)

(Default Type "J" Thermocouple Input)

Part Number	Output 1	Out 2/ Alm 1	Alarm 2 & 3
TEC36001	Relay	None	None
TEC36002	Relay	Relay	None
TEC36003	Relay	Relay	(2) Relays
TEC36004	Pulse DC	None	None
TEC36005	Pulse DC	Relay	None
TEC36006	Pulse DC	Relay	(2) Relays
TEC36007	4-20mA	None	None
TEC36008	4-20mA	Relay	(2) Relays



Note: All Stock Part Numbers Include Terminal Covers

Analog Retransmission

Output signal: 4-20 mA, 0-20 mA, 0-10V
Resolution: 15 bits **Accuracy:** ±0.05% of span ± 0.0025%/°C
Load Resistance: 0-500Ω for current output, 10KΩ minimum for voltage output
Isolation Breakdown: 1000VAC minimum
Integral Linearity Error: ±0.005% of span
Linear Output Ranges: 0-2.2mA (0-20mA/4-20mA), 0-5.55V (0-5V, 1-5V), 0-1.1V (0-10V)

User Interface

Keypad: 4 Keys **Display Type:** 4 digit LCD display
No. of Display: 3 **Upper Display Size:** 0.7" (17.7mm)
Lower Display Size: 0.4" (11.2mm)

Programming Port

Interface: Micro USB **PC Communication Function:** Automatic Setup, Calibration and Firmware Upgrade

Control Mode

Output 1: Reverse (Heating) or Direct (Cooling) Action
Output 2: PID cooling control, Cooling P band 50~300% of PB, Dead band -36.0 ~ 36.0 % of PB
ON-OFF: 0.1-90.0 (°F) hysteresis control (P band = 0)
P or PD: 0-100.0 % offset adjustment
PID: Fuzzy logic modified Proportional band 0.1 ~ 900.0°F, Integral time 0-3600 seconds, derivative time 0-360.0 seconds
Cycle Time: 0.1-90.0 Seconds
Manual Control: Heat (MV1) and cool (MV2)
Failure Mode: Auto transfer to manual mode while sensor break or A-D Converter damage
Ramping Control: 0-900.0°F/Minute or 0-900.0°F/Hour Ramp Rate

Profiler

Availability: Option **No. of Segments/ Program:** 4 / 8 / 16

Environmental and Physical Specifications

Operating Temp.: -10°C to 50°C **Storage Temp:** -40°C to 60°C
Humidity: 0 to 90 % RH (Non-condensing)
Insulation Resistance: 20MΩ minimum (@500V DC)
Dielectric Strength: 2000V AC, 50/60 Hz for 1 minute
Vibration Resistance: 10-55 Hz, 10m/s² for 2 hours
Shock Resistance: 200 m/s² (20g)
Moldings: Flame retardant polycarbonate
Mounting: Panel

	TEC-8400	TEC-8450
Dimensions H x W x D:	3-3/4 x 1-7/8 x 2-3/8" (96 x 48 x 59 mm)	1-7/8 x 3-3/4 x 2-3/8" (48 x 96 x 59 mm)
Depth Behind Panel:	2" (50 mm)	2" (50 mm)
Panel Cutout:	1-25/32 x 3-5/8" (45 x 92 mm)	3-5/8 x 1-25/32" (92 x 45 mm)
Weight:	.48 lbs. (220 g)	.48 lbs. (220 g)

Stock and Common Part Numbers (8450)

(Default Type "J" Thermocouple Input)

Part Number	Output 1	Out 2/ Alm 1	Option 1
TEC37001	Relay	None	None
TEC37002	Relay	Relay	None
TEC37003	Relay	Relay	(2) Relays
TEC37004	Pulse DC	None	None
TEC37005	Pulse DC	Relay	None
TEC37006	Pulse DC	Relay	(2) Relays
TEC37007	4-20mA	None	None
TEC37008	4-20mA	Relay	(2) Relays

Temperature Controllers



Model TEC-7400 3/16 DIN

Model TEC-7400 3/16 DIN Temperature Controller



Design Features

- * 3/16 DIN size – 72 mm × 72 mm
- * Fuzzy Logic PID Autotune heat and cool control
- * Universal input, field configurable (Type J T/C default, PT100, mA, V) with high accuracy 18-bit D-A
- * Countdown display
- * RS - 485 and Analog Retransmission Available
- * Micro USB Programming Port
- * Fast sampling rate (200 msec)
- * Manual control & auto-tune function
- * Wide range of alarm mode selection
- * Lockout protection
- * Bumpless transfer during failure mode
- * Soft-start ramp & dwell timer
- * Bright LCD display using NFPA/IEC standard colors
- * High performance with low cost

Agency Approvals:



RoHS, REACH, WEEE

Hardware Code: TEC-7400 - 1 2 3 4 5 6 7 8 9

A Part Number based on the hardware code and any software pre-programming will be issued at time of order.

Standard lead time is stock to 2 weeks.

Power Input BOX 1

- 4 = 90-250 VAC
- 5 = 11-40 VDC / 20-28 VAC

Output 1 BOX 2

- 1 = Relay: 2A / 240 VAC
- 2 = Pulse DC for SSR drive: 5 VDC (30 mA max)
- 3 = Isolated, 4-20 mA (default), 0-20 mA
- 5 = Isolated VDC, 0-10 scalable
- C = Pulse DC for SSR drive: 14 VDC (40 mA max)

Output 2 / Alarm 1 BOX 3

- 0 = None
- 1 = Relay: 2A / 240 VAC
- 2 = Pulse DC for SSR drive: 5 VDC (30 mA max)
- 3 = Isolated, 4-20 mA (default), 0-20 mA
- 5 = Isolated, VDC, 0-10 scalable
- C = Pulse DC for SSR drive: 14 VDC (40 mA max)

Alarm 2 and 3 BOX 4

- 0 = None
- 1 = Alarm 2: Relay: 2A / 240 VAC
- 2 = Alarm 2 and 3: Relays: 2A / 240 VAC

Event Inputs BOX 5

- 0 = None
- 1 = 6 Event Inputs

Option 1 BOX 6

- 0 = None
- 1 = RS-485 Interface & Remote Setpoint

Option 2 BOX 7

- 0 = None
- 1 = 1 CT Input and Remote Setpoint
- 2 = 2 CT Inputs and Remote Setpoint

Option 3 BOX 8

- 0 = None
- 1 = Retransmit: 4-20 mA / 0-20 mA and Remote Setpoint
- 2 = Retransmit: 0-10 VDC and Remote Setpoint
- 3 = Alarm 4 Relay: 2A / 240 VAC and Remote Setpoint

Option 4 BOX 9

- 0 = None
- 1 = Terminal Covers
- 2 = Ramp and Soak Firmware
- 3 = Terminal Covers and Ramp and Soak Firmware



Note: Detailed information on features common to digital microprocessor-based TEC temperature controls and the complete Table of Input Range and Accuracy can be found on page 13-46.

**Transformer for
Heater Break Alarm**
(0-50 Amp current)
Part Number: TEC99998
Specifications on page 13-47

Stock and Common Part Numbers

(All Stock Part Numbers Include Terminal Covers)
(Default Type "J" Thermocouple Input)

Part Number	Output 1	Out 2/ Alm 1	Option 1
TEC45001	Relay	None	None
TEC45002	Relay	Relay	None
TEC45003	Relay	Relay	(2) Relays
TEC45004	Pulse DC	None	None
TEC45005	Pulse DC	Relay	None
TEC45006	Pulse DC	Relay	(2) Relays
TEC45007	4-20mA	None	None
TEC45008	4-20mA	Relay	(2) Relays

Temperature Controllers



Model TEC-4400 1/4 DIN

Model TEC-4400 1/4 DIN Temperature Controller



Design Features

- * 1/4 DIN size – 96 mm × 96 mm
- * Fuzzy Logic PID Autotune heat and cool control
- * Universal input, field configurable (Type J T/C default, PT100, mA, V) with high accuracy 18-bit D-A
- * Countdown display
- * RS - 485 and Analog Retransmission Available
- * Micro USB Programming Port
- * Fast sampling rate (200 msec)
- * Manual control & auto-tune function
- * Wide range of alarm mode selection
- * Lockout protection
- * Bumpless transfer during failure mode
- * Soft-start ramp & dwell timer
- * Bright LCD display using NFPA/IEC standard colors
- * High performance with low cost

Agency Approvals:



RoHS, REACH, WEEE

Hardware Code: TEC-4400 - 1 2 3 4 5 6 7 8 9

A Part Number based on the hardware code and any software pre-programming will be issued at time of order.

Standard lead time is stock to 2 weeks.

Power Input BOX 1

- 4 = 90-250 VAC
- 5 = 11-40 VDC / 20-28 VAC

Output 1 BOX 2

- 1 = Relay: 2A / 240 VAC
- 2 = Pulse DC for SSR drive: 5 VDC (30 mA max)
- 3 = Isolated, 4-20 mA (default), 0-20 mA
- 5 = Isolated VDC, 0-10 scalable
- C = Pulse DC for SSR drive: 14 VDC (40 mA max)

Output 2 / Alarm 1 BOX 3

- 0 = None
- 1 = Relay: 2A / 240 VAC
- 2 = Pulse DC for SSR drive: 5 VDC (30 mA max)
- 3 = Isolated, 4-20 mA (default), 0
- 5 = Isolated, VDC, 0-10 scalable
- C = Pulse DC for SSR drive: 14 VDC (40 mA max)

Alarm 2 and 3 BOX 4

- 0 = None
- 1 = Alarm 2: Relay: 2A / 240 VAC
- 2 = Alarm 2 and 3: Relays: 2A / 240 VAC

Event Inputs BOX 5

- 0 = None
- 1 = 6 Event Inputs

Option 1 BOX 6

- 0 = None
- 1 = RS-485 Interface and Remote Setpoint

Option 2 BOX 7

- 0 = None
- 1 = 1 CT Input and Remote Setpoint
- 2 = 2 CT Inputs and Remote Setpoint

Option 3 BOX 8

- 0 = None
- 1 = Retransmit: 4-20 mA / 0-20 mA and Remote Setpoint
- 2 = Retransmit: 0-10 VDC and Remote Setpoint
- 3 = Alarm 4 Relay: 2A / 240 VAC and Remote Setpoint
- 4 = Alarm 4 Relay: 2A / 240 VAC, Retransmit: 4-20 mA / 0-20 mA and Remote Setpoint
- 5 = Alarm 4 Relay: 2A / 240 VAC, Retransmit: 0-10 VDC and Remote Setpoint

Option 4 BOX 9

- 0 = None
- 1 = Terminal Covers
- 2 = Ramp and Soak Firmware
- 3 = Terminal Covers and Ramp and Soak Firmware



Note: Detailed information on features common to digital microprocessor-based TEC temperature controls and the complete Table of Input Range and Accuracy can be found on page 13-46.

**Transformer for
Heater Break Alarm**
(0-50 Amp current)
Part Number: TEC99998
Specifications on page 13-47

Stock and Common Part Numbers

(All Stock Part Numbers Include Terminal Covers)
(Default Type "J" Thermocouple Input)

Part Number	Output 1	Out 2/ Alm 1	Alarm 2 & 3
TEC44001	Relay	None	None
TEC44002	Relay	Relay	None
TEC44003	Relay	Relay	(2) Relays
TEC44004	Pulse DC	None	None
TEC44005	Pulse DC	Relay	None
TEC44006	Pulse DC	Relay	(2) Relays
TEC44007	4-20mA	None	None
TEC44008	4-20mA	Relay	(2) Relays



Power Input

Standard: 90 to 250 VAC, 47–63 Hz, 12VA, 6W maximum
Optional: 11 to 40 VDC / 20 to 28 VAC, 47–63 Hz, 12VA, 6W maximum

Signal Input

Resolution: 18 Bits
Sampling Rate: 5 Times / Second (200msec)
Maximum Rating: -2VDC minimum, 12VDC maximum
Sensor Break Detection: Sensor open for Thermocouple and RTD inputs, sensor short for RTD input, below 1mA for 4-20mA input, below 0.25V for 1 - 5V input, not available for other inputs
Sensor break responding time: Within 4 seconds for Thermocouple and RTD inputs, 0.1 second for 4-20mA and 1 - 5V inputs

Remote Set Point Input

Type: Linear current, Linear voltage
Range: -3-27mA, -1.3-11.5V **Accuracy:** ±0.05 %
Input Impedance: Current: 2.5Ω, Voltage: 1.5MΩ
Resolution: 18 bits **Sampling Rate:** 1.66 times/second
Maximum Rating: 280mA maximum for Current Input, 12VDC maximum for Voltage Input
Sensor Break Detection: Below 1mA for 4-20mA input, below 0.25V for 1 - 5V input, not available for other inputs

Event Input

Number of Event Inputs: 6
Logic Low: -10V minimum, 0.8V maximum
Logic High: 2V minimum, 10V maximum

CT Input

CT type: TEC99998
Accuracy: ±2% of full scale reading, ± 1 digit maximum
Input Impedance: 294Ω
Measurement Range: 0-50A AC
Output of CT: 0-5V DC
CT Mounting: Wall (Screw) mount
Sampling Rate: 1 time/second

Output 1 /Output 2

Type: Relay, pulsed voltage, linear voltage and linear current
Relay Rating: 2A, 240V AC, 200000 life cycles for resistive load
Pulsed Voltage: Source voltage 5V, Current limiting resistance 66Ω
Linear Output Resolution: 15 Bits
Isolation Breakdown Voltage: 1000 V AC
Load Capacity of Linear Output: Linear current: 500Ω maximum, Linear voltage: 10KΩ minimum

Alarm

Relay Type: Form A
Maximum Rating: 2A, 240VAC, 200000 life cycles for resistive load
Alarm Functions: Dwell Timer, Deviation Low, Deviation High, Deviation Band Low, Deviation Band High, Process High, Process Low
Alarm Mode: Latching, Hold, Normal, Latching/Hold
Dwell Timer: 0.1-4553.6 minutes

Data Communications

Interface: RS-485 **Protocol:** Modbus RTU
Address: 1-247 **Baud Rate:** 2.8 - 115.2 Kbits/sec
Parity Bit: None, Even or Odd **Stop Bit:** 1 or 2 Bits
Data Length: 7 or 8 Bits **Communication Buffer:** 160 bytes

Analog Retransmission

Output Signal: 4-20 mA, 0-20 mA, 0-10V
Resolution: 15 Bits **Accuracy:** ±0.05% of span ± 0.0025% / °C
Load Resistance: 0-500Ω for current output, 10KΩ minimum for voltage output
Isolation Breakdown: 1000VAC minimum
Linear Output Ranges: 0-22.2mA (0-20mA / 4-20mA), 0-5.55V (0-5V, 1-5V), 0-11.1V (0-10V)

User Interface

Keypad: 4 Keys **Display Type:** 4 digit LCD display
No. of Display: 3
Upper Display Size: 0.98" (25mm)
Lower Display Size: 0.55" (14mm)

Programming Port

Interface: Micro USB
PC Communication Function: Automatic Setup, Calibration and Firmware Upgrade

Control Mode

Output 1: Reverse (Heating) or Direct (Cooling) Action
Output 2: PID cooling control, Cooling P band 50~300% of PB, Dead band -36.0 ~ 36.0 % of PB
ON-OFF: 0.1-90.0 (°F) hysteresis control (P band = 0)
P or PD: 0-100.0 % offset adjustment
PID: Fuzzy logic modified Proportional band 0.1 ~ 900.0°F, Integral time 0~3600 seconds, Derivative time 0-360.0 seconds
Cycle Time: 0.1-90.0 seconds
Manual Control: Heat (MV1) and Cool (MV2)
Failure Mode: Auto transfer to manual mode while sensor break or A-D Converter damage
Ramping Control: 0 to 900.0°F / Minute or 0 to 900.0°F / Hour Ramp Rate

Environmental and Physical Specifications

Operating Temperature: -10°C to 50°C
Storage Temperature: -40°C to 60°C
Humidity: 0 to 90 % RH (Non-Condensing)
Insulation Resistance: 20MΩ minimum (@500V DC)
Dielectric Strength: 2000V AC, 50/60 Hz for 1 Minute
Vibration Resistance: 10 to 55 Hz, 10m/s² for 2 Hours
Shock Resistance: 200 m / s² (20g)
Moldings: Flame retardant polycarbonate
Mounting: Panel
Dimensions W × H × D: 3-3/4 × 3-3/4 × 2-3/8" (96 × 96 × 59 mm)
Depth Behind Panel: 2" (50 mm)
Cut Out Dimensions: 3-5/8 × 3-5/8" (92 × 92 mm)
Weight: .64 lbs. (290 g)

Rear Terminal Connections

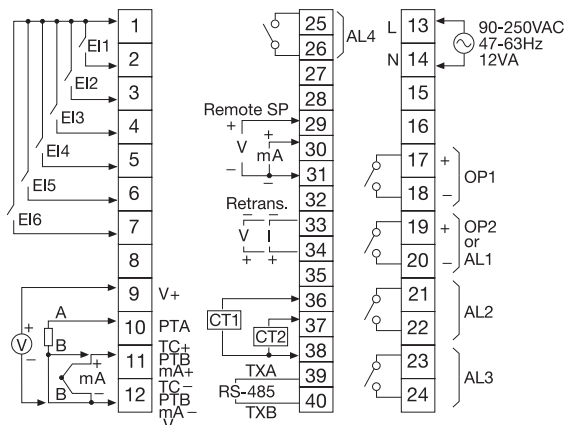

Model TEC-6400 DIN Rail Mount Temperature Controller



Design Features

- * DIN Rail Mount, 35 mm
- * Fuzzy Logic PID Autotune heat and cool control
- * Universal input, field configurable (Type J T/C default, PT100, mA, V) with high accuracy 18-bit D-A
- * Countdown display
- * RS - 485 and Analog Retransmission Available
- * Micro USB Programming Port
- * Fast sampling rate (200 msec)
- * Manual control & auto-tune function
- * Wide range of alarm mode selection
- * Lockout protection
- * Bumpless transfer during failure mode
- * Soft-start ramp & dwell timer
- * Bright LCD display using NFPA/IEC standard colors
- * High performance with low cost

Agency Approvals:



RoHS, REACH, WEEE

Hardware Code: TEC-6400 - 1 2 3 4 5

A Part Number based on the hardware code and any software pre-programming will be issued at time of order.

Standard lead time is stock to 2 weeks.

Power Input BOX 1

- 4 = 90-250 VAC
- 5 = 11-40 VDC / 20-28 VAC

Output 1 BOX 2

- 1 = Relay: 2A / 240 VAC
- 2 = Pulse DC for SSR drive: 5 VD (30 mA max)
- 3 = Isolated, 4-20 mA (default), 0-20 mA
- 5 = Isolated VDC, 0-10 scalable
- C = Pulse DC for SSR drive: 14 VDC (40mA max)

Output 2 / Alarm 1 BOX 3

- 0 = None
- 1 = Relay: 2A / 240 VAC
- 2 = Pulse DC for SSR drive: 5 VDC (30 mA max)
- 3 = Isolated, 4-20 mA (default), 0-20 mA
- 5 = Isolated, VDC, 0-10 scalable
- C = Pulse DC for SSR drive: 14 VDC (40mA max)

Option 1 BOX 4

- 0 = None
- 1 = RS-485 Interface
- 2 = 1 Event Input EI 1
- 3 = 1 CT Input (CT 1)

Option 2 BOX 5

- 0 = None
- 1 = Retransmit: 4-20mA / 0-20mA
- 2 = Retransmit: 0-10 VDC
- 3 = Alarm 2 Relay: 2A / 240 VAC
- 4 = 1 Event Input EI 2
- 5 = 1 CT Input (CT 2)



Note: Detailed information on features common to digital microprocessor-based TEC temperature controls and the complete Table of Input Range and Accuracy can be found on page 13-46.

Transformer for Heater Break Alarm

(0-50 Amp current)

Part Number: TEC99998

Specifications on page 13-47



Power Input

Standard: 90-250 VAC, 47-63 Hz, 8VA, 4W maximum
Optional: 11-40 VDC / 20-8 VAC, 47-63 Hz, 8VA, 4W maximum

Signal Input

Resolution: 18 Bits
Sampling Rate: 5 Times / Second (200msec)
Maximum Rating: -2VDC minimum, 12VDC maximum
Sensor Break Detection: Sensor open for thermocouple and RTD inputs, sensor short for RTD input, below 1mA for 4-20mA input, below 0.25V for 1-5V input, not available for other inputs
Sensor break responding time: Within 4 seconds for thermocouple and RTD inputs, 0.1 second for 4-20mA and 1-5V inputs

Event Input

Number of Event Inputs: 1
Logic Low: -10V minimum, 0.8V maximum
Logic High: 2V minimum, 10V maximum

CT Input

CT type: TEC99998
Accuracy: $\pm 2\%$ of full scale reading, ± 1 digit maximum
Input Impedance: 294 Ω
Measurement Range: 0-50A AC
Output of CT: 0-5V DC
CT Mounting: Wall (Screw) mount
Sampling Rate: 1 time/second

Output 1 /Output 2

Type: Relay, pulsed voltage, linear voltage and linear current
Relay Rating: 2A, 240V AC, 200000 life cycles for resistive load
Pulsed Voltage: Source voltage 5V, Current limiting resistance 66 Ω
Linear Output Resolution: 15 Bits
Isolation Breakdown Voltage: 1000 V AC
Load Capacity of Linear Output: Linear current: 500 Ω maximum, Linear voltage: 10K Ω minimum

Alarm

Relay Type: Form A
Maximum Rating: 2A, 240VAC, 200000 life cycles for resistive load
Alarm Functions: Dwell timer, Deviation low, Deviation high, Deviation band low, Deviation band high, Process high, Process low
Alarm Mode: Latching, Hold, Normal, Latching/Hold
Dwell Timer: 0.1-4553.6 minutes

Data Communications

Interface: RS-485
Address: 1-247
Parity Bit: None, Even or Odd
Data Length: 7 or 8 Bits
Protocol: Modbus RTU
Baud Rate: 2.8 - 115.2 Kbits/sec
Stop Bit: 1 or 2 Bits
Communication Buffer: 160 bytes

Analog Retransmission

Output Signal: 4-20 mA, 0-20 mA, 0-10V
Resolution: 15 Bits
Accuracy: $\pm 0.05\%$ of span $\pm 0.0025\%$ / $^{\circ}\text{C}$
Load Resistance: 0-500 Ω for current output, 10K Ω minimum for voltage output
Isolation Breakdown: 1000VAC minimum
Linear Output Ranges: 0-22.2mA (0-20mA / 4-20mA), 0-5.55V (0-5V, 1-5V), 0-11.1V (0-10V)

User Interface

Keypad: 4 Keys
Display Type: 4 digit LCD display
No. of Display: 2
Upper Display Size: 0.31" (8mm)
Lower Display Size: 0.25" (6.5mm)

Programming Port

Interface: Micro USB
PC Communication Function: Automatic Setup, Calibration and Firmware Upgrade

Control Mode

Output 1: Reverse (Heating) or Direct (Cooling) Action
Output 2: PID cooling control, Cooling P band 50~300% of PB, Dead band -36.0 ~ 36.0 % of PB
ON-OFF: 0.1-90.0 ($^{\circ}\text{F}$) hysteresis control (P band = 0)
P or PD: 0-100.0 % offset adjustment
PID: Fuzzy logic modified Proportional band 0.1 ~ 900.0 $^{\circ}\text{F}$, Integral time 0-3600 seconds, Derivative time 0-360.0 seconds
Cycle Time: 0.1-90.0 seconds
Manual Control: Heat (MV1) and Cool (MV2)
Failure Mode: Auto transfer to manual mode while sensor break or A-D Converter damage
Ramping Control: 0 to 900.0 $^{\circ}\text{F}$ / Minute or 0 to 900.0 $^{\circ}\text{F}$ / Hour Ramp Rate

Environmental and Physical Specifications

Operating Temperature: -10 $^{\circ}\text{C}$ to 50 $^{\circ}\text{C}$
Storage Temperature: -40 $^{\circ}\text{C}$ to 60 $^{\circ}\text{C}$
Humidity: 0 to 90 % RH (Non-Condensing)
Insulation Resistance: 20M Ω minimum (@500V DC)
Dielectric Strength: 2000V AC, 50/60 Hz for 1 Minute
Vibration Resistance: 10 to 55 Hz, 10m/s² for 2 Hours
Shock Resistance: 200 m / s² (20g)
Moldings: Flame retardant polycarbonate
Mounting: DIN Rail, 35 mm
Dimensions W x H x D: 3-3/4 x 7/8 x 3-11/16" (96 x 22.5 x 83 mm)
Depth Behind Panel (mm): n/a
Cut Out Dimensions (mm): n/a
Weight: .35 lbs. (160 g)

Rear Terminal Connections

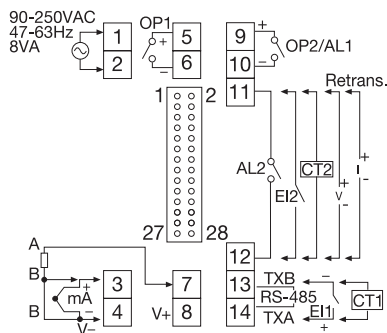

Stock and Common Part Numbers

(Default Type "J" Thermocouple Input)

Part Number	Output 1	Out 2/ Alm 1	Option 2
TEC80001	Relay	None	None
TEC80002	Relay	Relay	None
TEC80003	Relay	Relay	Relay
TEC80004	Pulse DC	None	None
TEC80005	Pulse DC	Relay	None
TEC80006	Pulse DC	Relay	Relay
TEC80007	4-20mA	None	None
TEC80008	4-20mA	Relay	Relay

Model TEC-220 1/32 DIN Temperature Controller



Configurable for 3 Programmable Outputs!

Agency Approvals:



Design Features

- * 1/32 DIN size – 24 mm × 48 mm
- * Fuzzy Logic PID Autotune heat and cool control
- * Short panel depth – only 3-7/8" (98 mm) required
- * Universal input, field configurable (Type J T/C default, PT100, mA, V) with high accuracy 18-bit D-A
- * Highly versatile – 6 types of inputs available
- * Output 2 can be programmed as output or alarm
- * NEMA 4X / IP65 gasketed front panel
- * Universal input power, 90-250 VAC or 11-26 VAC/VDC
- * Highly accurate universal input with 18 bit analog to digital converter
- * Bumpless transfer to manual mode during sensor failure
- * Wide variety of alarm mode selections
- * RS-485 and RS-232 data communications interface optional
- * Bright 0.40" (10 mm) LED display
- * High performance at a very low price

Hardware Code: TEC-220- 1 2 3 4 5 6

A Part Number based on the hardware code and any software pre-programming will be issued at time of order.

Standard lead time is stock to 2 weeks.

Power Input BOX 1

- 4** = 90-250 VAC
- 5** = 11-26 VAC / VDC
- 9** = Other

Signal Input – Universal, can be programmed BOX 2 in the field for item 5 or 6

- 5** = Thermocouple: *J, K, T, E, B, R, S, N, L
0-60mV
- 6** = RTD: *PT100 DIN, PT100 JIS
- 7** = 0-1 VDC
- 8** = *0-5, 1-5 VDC
- A** = 0-10 VDC
- B** = *4-20, 0-20 mA
- 9** = Other * indicates default value

Output 1 BOX 3

- 1** = Relay: 2A / 240 VAC
- 2** = Pulse DC for SSR drive: 5 VDC (30 mA max)
- 3** = Isolated, 4-20 mA (default), 0-20 mA
- 4** = Isolated, VDC, 1-5 (default), 0-5, 0-1
- 5** = Isolated, VDC, 0-10
- 6** = Triac-SSR output 1A/240 VAC
- C** = Pulse DC for SSR drive: 14 VDC (40 mA max)
- 9** = Other

Output 2 / Alarm 1 BOX 4

- 0** = None
- 1** = Relay: 2A / 240 VAC
- 2** = Pulse DC for SSR drive: 5 VDC (30 mA max)
- 3** = Isolated, 4-20 mA (default), 0-20 mA
- 4** = Isolated VDC, 1-5 (default), 0-5, 0-1
- 5** = Isolated VDC, 0-10
- 6** = Triac-SSR output 1A / 240 VAC
- 8** = Isolated 20V @ 25 mA DC, Output Power Supply
- A** = Isolated 12V @ 40 mA DC, Output Power Supply
- 9** = Isolated 5V @ 80 mA DC, Output Power Supply
- C** = Pulse DC for SSR drive: 14 VDC (40 mA max)
- B** = Other

Communications BOX 5

- 0** = None
- 1** = RS-485 interface
- 2** = RS-232 interface
- 3** = Retransmission 4-20 mA (default), 0-20 mA
- 4** = Retransmission 1-5 VDC (default), 0-5 VDC
- 5** = Retransmission 0-10 VDC
- 9** = Other

Units – °F or °C BOX 6

- 1** = °F on faceplate
- 2** = °C on faceplate
- 3** = None (process units)



Note: Detailed information on features common to digital microprocessor-based TEC temperature controls and the complete Table of Input Range and Accuracy can be found on page 13-46.

Power Input

Standard: 90-250 VAC, 47-63 Hz, 10 VA, 5W maximum
Optional: 11-26 VAC / VDC, 10 VA, 5W maximum

Signal Input

Resolution: 18 bits
Sampling Rate: 5 samples / second
Accuracy: $\pm 0.24\%$ of span typical
Maximum Rating: -2 VDC minimum, 12 VDC maximum (1 minute for mA input)
Temperature Effect: $\pm 1.5 \mu V / ^\circ C$ for all inputs except mA input $\pm 3.0 \mu V / ^\circ C$ for mA input

Sensor Lead Resistance Effect: T/C: $0.2 \mu V / \text{ohm}$
 3-wire RTD: $2.6^\circ C / \text{ohm}$ of resistance difference of two leads

Burn-out Current: 200nA

Common Mode Rejection Ratio (CMRR): 120 dB

Normal Mode Rejection Ratio (NMRR): 55 dB

Sensor Break Detection: Sensor open for TC, RTD and mV inputs; sensor short for RTD input; below 1 mA for 4-20 mA input; below 0.25V for 1-5V input; unavailable for other inputs

Sensor Break Response Time: Within 4 seconds for TC, RTD and mV inputs; 0.1 second for 4-20 mA and 1-5 V inputs

Output 1 / Output 2

Relay Rating: 240 VAC, 2 Amp

Pulsed Voltage: Source voltage 5V, Current limiting resistance 66 Ω

Linear Output — Characteristics

Type	Zero	Span	Load
Tolerance	Tolerance	Capacity	
4-20 mA	3.6-4.0 mA	20-21 mA	500 Ω max
0-20 mA	0 mA	20-21 mA	500 Ω max
0-5 VDC	0 VDC	5-5.25 VDC	10 K Ω min
1-5 VDC	0.9-1.0 VDC	5-5.25 VDC	10 K Ω min
0-10 VDC	0 VDC	10-10.5 VDC	10 K Ω min

Resolution: 15 bit analog to digital converter

Output Regulation: 0.02% for full load change

Output Settling Time: 0.1 sec. (stable to 99.9%)

Isolation Breakdown Voltage: 1000 VAC

Temperature Effect: $\pm 0.01\%$ of span/ $^\circ C$

Solid State Relay (Triac) Output

Rating: 1A / 240 VAC

Inrush Current: 20A for 1 cycle

Min. Load Current: 50 mA rms

Max. Off-state Leakage: 3 mA rms

Max. On-state Voltage: 1.5 VAC rms

Insulation Resistance: 1000 Megohms minimum at 500 VDC

Dielectric Strength: 2500 VAC for 1 minute

Rear Terminal Connections

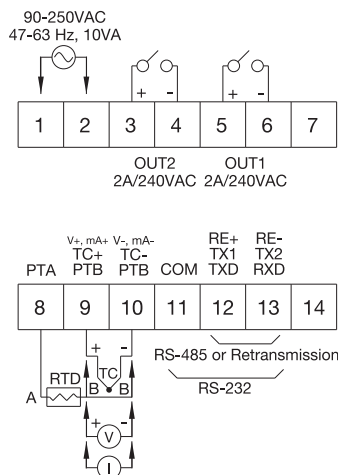

Output 2 / Alarm 1 — Programmable

Alarm 1 Relay: Form A, (NO)

Maximum rating: 240 VAC, 2 Amp

Alarm Functions: Dwell timer

Deviation High / Low Alarm

Deviation Band High / Low Alarm

Process High / Low Alarm

Sensor Break Alarm

Alarm Mode: Normal, Latching, Hold, Latching / Hold

Dwell Timer: 0 - 4553.6 minutes

Data Communications

Interface: RS-232 (1 unit), RS-485 (up to 247 units)

Protocol: Modbus Protocol – RTU mode

Address: 1-247

Baud Rate: 0.3 - 38.4 Kbits/sec

Data Bits: 7 or 8 bits

Parity Bit: None, Even or Odd

Stop Bit: 1 or 2 bits

Communication Buffer: 160 bytes

User Interface

Single 4-digit LED Display: 0.4" / 10 mm **Keypad:** 3 keys

Programming Port: For automatic setup, calibration and testing

Control Mode

Output 1: Reverse (heating) or direct (cooling) action

Output 2: PID cooling control, cooling P band 50-300% of PB, dead band -36.0 to 36.0% of PB

On-Off: 0.1 - 90.0 $^\circ F$ hysteresis control (P band = 0)

P or PD: 0 - 100.0% offset adjustment

PID: Fuzzy logic modified

Proportional band: 0.1 - 900 $^\circ F$

Integral time: 0 - 1000 seconds

Derivative time: 0 - 360 seconds

Cycle Time: 0.1 - 90 seconds

Manual Control: Heat (MV1) and Cool (MV2)

Auto-tuning: Cold start and warm start

Failure Mode: Auto-transfer to manual mode with sensor break or A-D converter damage

Ramping Control: 0 - 900 $^\circ F$ /min or 0 - 900 $^\circ F$ /hr ramp rate

Environmental and Physical

Operating Temperature: 14 to 122 $^\circ F$ (-10 to 50 $^\circ C$)

Storage Temperature: -40 to 140 $^\circ F$ (-40 to 60 $^\circ C$)

Humidity: 0 to 90% RH, non-condensing

Dielectric Strength: 2000 VAC, 50/60 Hz for 1 minute

Dimensions: 1-3/64 \times 2 \times 4-3/8" (26.5 \times 50 \times 110.5 mm) H \times W \times D
 Depth behind panel: 3-7/8" (98 mm)

Panel Cutout: 7/8 \times 1-25/32" (22 \times 45 mm) H \times W

Weight: 0.26 lb. (120 grams)

Approval Standards

Safety: UL61010C-1, CSA C22.2 No. 24-93

EN61010-1 (IEC1010-1)

Protective Class: Front Panel: NEMA 4X / IP65

Housing and Terminals: IP 20

EMC: EN61326

Stock and Common Part Numbers (Power Input: 90-250 VAC, no data com)

Part Number	Signal Input	Out 1	Out 2 / Alarm 1	$^\circ F / ^\circ C$
TEC03001	tc	relay	none	$^\circ F$
TEC03002	tc	relay	relay	$^\circ F$
TEC03003	tc	4-20 mA	none	$^\circ F$
TEC03004	tc	DC pulse	none	$^\circ F$
TEC03005	RTD	relay	none	$^\circ F$
TEC03006	RTD	DC pulse	none	$^\circ F$
TEC03007	tc	relay	none	$^\circ C$
TEC03008	tc	4-20 mA	none	$^\circ C$
TEC03009	RTD	relay	none	$^\circ C$

Model TEC-2500 1/32 DIN Temperature Controller



Configurable for 4 Programmable Outputs!

Agency Approvals: RoHS



Design Features

- * 1/32 DIN size – 24 mm × 48 mm
- * Fuzzy Logic PID Autotune heat & cool control
- * Short panel depth – only 3-7/8" (98 mm) required
- * Universal input, field configurable (Type J T/C default, PT100, mA, V) with high accuracy 18-bit D-A
- * Heater Break Alarm using 0-50 Amp current transformer
- * Output 2 can be programmed as output or alarm
- * NEMA 4X / IP65 gasketed front panel
- * Alarm 1 – programmable 5 VDC logic output
- * Universal input power, 90-264 VAC or 11-26 VAC/VDC
- * Bumpless transfer to manual mode during sensor failure
- * Power limiter output
- * Wide variety of alarm mode selections
- * RS-485 and RS-232 data communications interface
- * Bright 0.40" (10 mm) LED display
- * Fast input sample rate (5 samples/second)
- * Automatic programming
- * Differential control
- * "Soft-Start" ramp and dwell timer
- * Analog input for remote setpoint and current transformer
- * Event input for changing functions and setpoint
- * Hardware lockout plus remote lockout protection
- * Loop break alarm
- * Analog retransmission
- * DC power supply outputs
- * High performance at a low price

Hardware Code: TEC-2500-

1	2	3	4	5	6	7
---	---	---	---	---	---	---

A Part Number based on the hardware code and any software pre-programming will be issued at time of order.

Standard lead time is stock to 2 weeks.

Power Input BOX 1

- 4 = 90-264 VAC
- 5 = 11-26 VAC / VDC
- 9 = Other

Signal Input – Universal, can be programmed in the field BOX 2

- 1 = Input 1 – Universal input (factory default = tc type J)
Thermocouple: J, K, T, E, B, R, S, N, L
RTD: PT100 DIN, PT100 JIS
Current: 4-20 mA, 0-20 mA
Voltage: VDC, 0-1, 0-5, 1-5, 0-10
- Input 2 – not available if RS-232 is specified
CT: 0 - 50A AC current Transformer (factory default)
Voltage Input: 0-1V, 0-5V, 1-5V, 0-10V
Event Input
- 9 = Other

Output 1 BOX 3

- 1 = Relay: 2A / 240 VAC
- 2 = Pulse DC for SSR drive: 5 VDC (30 mA max)
- 3 = Isolated, 4-20 mA (default), 0-20 mA
- 4 = Isolated, VDC, 1-5 (default), 0-5, 0-1
- 5 = Isolated, VDC, 0-10
- 6 = Triac-SSR output 1A / 240 VAC
- C = Pulse DC for SSR drive: 14 VDC (40 mA max)
- 9 = Other

Output 2 / Alarm 2 BOX 4

- 0 = None
- 1 = Relay: 2A / 240 VAC
- 2 = Pulse DC for SSR drive: 5 VDC (30 mA max)
- 3 = Isolated, 4-20 mA (default), 0-20 mA
- 4 = Isolated VDC, 1-5 (default), 0-5, 0-1
- 5 = Isolated VDC, 0-10
- 6 = Triac-SSR output 1A / 240 VAC
- 7 = Isolated 20V @ 25 mA DC, Output Power Supply
- 8 = Isolated 12V @ 40 mA DC, Output Power Supply
- 9 = Isolated 5V @ 80 mA DC, Output Power Supply
- C = Pulse DC for SSR drive: 14 VDC (40 mA max)
- A = Other

Alarm 1 BOX 5

- 1 = 5 VDC Logic Output
- 9 = Other

Communications BOX 6

- 0 = None
- 1 = RS-485 Interface
- 2 = RS-232 Interface
- 3 = Retransmission 4-20 mA (default), 0-20 mA
- 4 = Retransmission 1-5 VDC (default), 0-5 VDC
- 5 = Retransmission 0-10 VDC
- 9 = Other

Units – °F or °C BOX 7

- 1 = °F on faceplate
- 2 = °C on faceplate
- 3 = None (process units)



Note: Detailed information on features common to digital microprocessor-based TEC temperature controls and the complete Table of Input Range and Accuracy can be found on page 13-46.

Transformer for Heater Break Alarm

(0-50 Amp current)

Part Number: TEC99999

Specifications on page 13-47



Power Input

Standard: 90-264 VAC, 47-63 Hz, 15 VA, 7W maximum
Optional: 11-26 VAC / VDC, 15 VA, 7W maximum

Signal Input

Input 1

Resolution: 18 bits **Sampling Rate:** 5 samples / second
Accuracy: ±.24% of span typical
Maximum Rating: -2 VDC minimum, 12 VDC maximum (1 minute for mA input)

Temperature Effect: ±1.5 $\mu\text{V} / ^\circ\text{C}$ for all inputs except mA input
 ±3.0 $\mu\text{V} / ^\circ\text{C}$ for mA input

Sensor Lead Resistance Effect: T/C: 0.2 $\mu\text{V}/\text{ohm}$
 3-wire RTD: 2.6 $^\circ\text{C}/\text{ohm}$ of resistance difference of two leads

Burn-out Current: 200nA

Common Mode Rejection Ratio (CMRR): 120 dB

Normal Mode Rejection Ratio (NMRR): 55 dB

Sensor Break Detection: Sensor open for TC, RTD and mV inputs;
 sensor short for RTD input; below 1 mA for 4-20 mA input;
 below 0.25V for 1-5V input; unavailable for other inputs

Sensor Break Response Time: Within 4 seconds for TC, RTD and mV inputs;
 0.1 second for 4-20 mA and 1-5 V inputs

Input 2

Resolution: 18 bits

Sampling Rate: 1.66 times per second

Sensor Break Response Time: 0.5 second

Types: **Current Transducer:** 0 to 50 Amp
mA: -3 to 27 mA **V:** -1.3 to 11.5 VDC

Event Input Functions: Select 2nd setpoint and/or PID, disable output 1 and/or output 2, remote lockout, reset alarm 1 and/or alarm 2

Output 1 or Output 2 / Alarm 2

Relay Rating: 240 VAC, 2 Amp

Pulsed Voltage: Source voltage 5V,
 Current limiting resistance 66 Ω

Linear Output — Characteristics

Type	Zero Tolerance	Span Capacity	Load
4-20 mA	3.6-4.0 mA	20-21 mA	500 Ω max
0-20 mA	0 mA	20-21 mA	500 Ω max
0-5 VDC	0 VDC	5-5.25 VDC	10 K Ω min
1-5 VDC	0.9-1.0 VDC	5-5.25 VDC	10 K Ω min
0-10 VDC	0 VDC	10-10.5 VDC	10 K Ω min

Resolution: 15 bit analog to digital converter

Isolation Breakdown Voltage: 1000 VAC

Solid State Relay (Triac) Output

Rating: 1A / 240 VAC **Inrush Current:** 20A for 1 cycle

Min. Load Current: 50 mA rms

Max. Off-state Leakage: 3 mA rms

Max. On-state Voltage: 1.5 VAC rms

Insulation Resistance: 1000 Megohms minimum at 500 VDC

Dielectric Strength: 2500 VAC for 1 minute

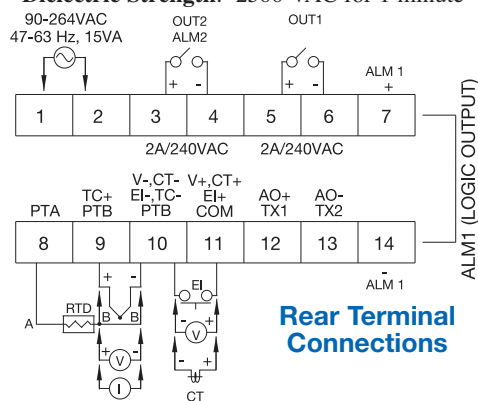

Rear Terminal Connections

Alarm 1 / Alarm 2

Alarm 1: 5 VDC logic output

Alarm 2 Relay: Form A, (NO) **Maximum rating:** 240 VAC, 2 Amp

Alarm Functions:

Dwell timer PV1-PV2 High / Low Alarm
 Deviation Band High / Low Alarm Loop Break Alarm
 PV2 High / Low Alarm Sensor Break Alarm

Alarm Mode: Normal, Latching, Hold, Latching / Hold

Dwell Timer: 0 - 6553.5 minutes

Data Communications

Interface: RS-232 (1 unit), RS-485 (up to 247 units)

Protocol: Modbus Protocol – RTU mode

User Interface

Single 4-digit LED Displays: 0.4" / 10 mm Keypad: 3 keys

Programming Port: For automatic setup, calibration and testing

Control Mode

Output 1: Reverse (heating) or direct (cooling) action

Output 2: PID cooling control, cooling P band 1-255% of PB

On-Off: 0.1 - 100.0 $^\circ\text{F}$ hysteresis control (P band = 0)

P or PD: 0 - 100.0% offset adjustment

PID: Fuzzy logic modified

Proportional band: 0.1 - 900 $^\circ\text{F}$ (500 $^\circ\text{C}$)

Integral: 0 - 1000 seconds **Derivative:** 0 - 360 seconds

Cycle Time: 0.1 - 100 seconds

Manual Control: Heat (MV1) and Cool (MV2)

Auto-tuning: Cold start and warm start

Failure Mode: Auto-transfer to manual mode with sensor break or A-D converter damage

Ramping Control: 0 - 900 $^\circ\text{F}/\text{min}$ or 0 - 900 $^\circ\text{F}/\text{hr}$ ramp rate

Power Limit: 0 - 100% for output 1 and output 2

Remote Setpoint: Programmable range for voltage or current input

Digital Filter: Time constant: settable from 0.2 to 60 seconds

Analog Retransmission

Analog Retransmission Functions: PV1, PV2, PV1-PV2, PV2-PV1, setpoint, MV1, MV2, PV-SV deviation value

Output Signal: 4-20 / 0-20 mA, 0-1, 0-5, 1-5, 0-10 VDC

Accuracy: ±0.05 % of span, ±0.0025 %/ $^\circ\text{C}$

Environmental and Physical

Operating Temperature: 14 to 122 $^\circ\text{F}$ (-10 to 50 $^\circ\text{C}$)

Storage Temperature: -40 to 140 $^\circ\text{F}$ (-40 to 60 $^\circ\text{C}$)

Humidity: 0 to 90% RH, non-condensing

Dielectric Strength: 2000 VAC, 50/60 Hz for 1 minute

Dimensions: 1-3/64 × 2 × 4-3/8" (26.5 × 50 × 110.5 mm) H×W×D
 Depth behind panel: 3-7/8" (98 mm)

Panel Cutout: 7/8 × 1-25/32" (22 × 45 mm) H×W

Weight: 0.26 lb. (120 grams)

Approval Standards

Safety Standard: UL 3121-1, CSA C22.2 No. 24-93
 EN61010-1 (IEC1010-1)

EMC: EN61325

Protective Class: Front Panel: NEMA 4X / IP65
 Housing and Terminals: IP 20

Stock and Common Part Numbers
(Power Input: 90-264 VAC, w/ alarm 1, no data com)

Part Number	Signal Input	Out 1	Out 2 / Alarm 2	$^\circ\text{F}/^\circ\text{C}$
TEC02001	tc	relay	none	$^\circ\text{F}$
TEC02002	tc	relay	relay	$^\circ\text{F}$
TEC02003	tc	4-20 mA	none	$^\circ\text{F}$
TEC02004	tc	4-20 mA	relay	$^\circ\text{F}$
TEC02005	tc	DC pulse	none	$^\circ\text{F}$
TEC02006	tc	relay	none	$^\circ\text{C}$
TEC02007	tc	4-20 mA	none	$^\circ\text{C}$
TEC02008	tc	DC pulse	none	$^\circ\text{C}$

Model TEC-920 1/16 DIN Temperature Controller



Single Display, Configurable for 2 Programmable Outputs!

Agency Approvals:



Design Features

- * 1/16 DIN size – 48 mm × 48 mm
- * Fuzzy Logic PID Autotune heat & cool control
- * Short panel depth – only 3-3/8" (86 mm) required
- * Universal input, field configurable (Type J T/C default, PT100, mA, V) with high accuracy 18-bit D-A
- * Highly versatile – 6 types of inputs available
- * Output 2 can be programmed as output or alarm
- * Universal input power – 90-250 VAC or 11-26 VAC/VDC
- * Highly accurate universal input with 18 bit analog to digital converter
- * Bumpless transfer to manual mode during sensor failure
- * Wide variety of alarm mode selections
- * Optional RS-485 communications interface
- * Bright 0.40" (10 mm) LED display
- * High performance at a very low price

Hardware Code: TEC-920- 1 2 3 4

A Part Number based on the hardware code and any software pre-programming will be issued at time of order.

Standard lead time is stock to 2 weeks.

Power Input BOX 1

- 4** = 90-250 VAC
- 5** = 11-26 VAC / VDC
- 9** = Other

Signal Input— Universal, can be programmed BOX 2 in the field for item 5 or 6

- 5** = Thermocouple: *J, K, T, E, B, R, S, N, L
0-60mV
- 6** = RTD: *PT100 DIN, PT100 JIS
- 7** = 0-1 VDC
- 8** = *0-5, 1-5 VDC
- A** = 0-10 VDC
- B** = *4-20, 0-20 mA
- 9** = Other * indicates default value

Output 1 BOX 3

- 1** = Relay: 2A / 240 VAC
- 2** = Pulse DC for SSR drive: 5 VDC (30 mA max)
- 3** = Isolated, 4-20 mA (default), 0-20 mA
- 4** = Isolated, VDC, 1-5 (default), 0-5, 0-1
- 5** = Isolated, VDC, 0-10
- 6** = Triac-SSR output 1A / 240 VAC
- C** = Pulse DC for SSR drive: 14 VDC (40 mA max)
- 9** = Other

Output 2 / Alarm 1 BOX 4

- 0** = None
- 1** = Relay: 2A / 240 VAC
- 2** = Pulse DC for SSR drive: 5 VDC (30 mA max)
- 3** = Isolated, 4-20 mA (default), 0-20 mA
- 4** = Isolated VDC, 1-5 (default), 0-5, 0-1
- 5** = Isolated VDC, 0-10
- 6** = Triac-SSR output 1A / 240 VAC
- 7** = RS-485 Data Interface
- 8** = Isolated 20V @ 25 mA DC, Output Power Supply
- A** = Isolated 12V @ 40 mA DC, Output Power Supply
- 9** = Isolated 5V @ 80 mA DC, Output Power Supply
- C** = Pulse DC for SSR drive: 14 VDC (40 mA max)
- B** = Other



Note: Detailed information on features common to digital microprocessor-based TEC temperature controls and the complete Table of Input Range and Accuracy can be found on page 13-46.

Power Input

Standard: 90-250 VAC, 47-63 Hz, 10 VA, 5W maximum
Optional: 11-26 VAC / VDC, 10 VA, 5W maximum

Signal Input

Resolution: 18 bits **Sampling Rate:** 5 samples / second
Accuracy: $\pm 0.24\%$ of span typical
Maximum Rating: -2 VDC minimum, 12 VDC maximum (1 minute for mA input)
Temperature Effect: $\pm 1.5 \mu\text{V} / ^\circ\text{C}$ for all inputs except mA input
 $\pm 3.0 \mu\text{V} / ^\circ\text{C}$ for mA input
Sensor Lead Resistance Effect: T/C: $0.2 \mu\text{V}/\text{ohm}$
 3-wire RTD: $2.6^\circ\text{C}/\text{ohm}$ of resistance difference of two leads
Burn-out Current: 200nA
Common Mode Rejection Ratio (CMRR): 120 dB
Normal Mode Rejection Ratio (NMRR): 55 dB
Sensor Break Detection: Sensor open for TC, RTD and mV inputs; sensor short for RTD input; below 1 mA for 4-20 mA input; below 0.25V for 1-5V input; unavailable for other inputs
Sensor Break Response Time: Within 4 seconds for TC, RTD and mV inputs; 0.1 second for 4-20 mA and 1-5 V inputs

Output 1 / Output 2

Relay Rating: 240 VAC, 2 Amp
Pulsed Voltage: Source voltage 5V, Current limiting resistance 66 Ω

Linear Output — Characteristics

Type	Zero	Span	Load
Tolerance	Tolerance	Capacity	
4-20 mA	3.6-4.0 mA	20-21 mA	500 Ω max
0-20 mA	0 mA	20-21 mA	500 Ω max
0-5 VDC	0 VDC	5-5.25 VDC	10 K Ω min
1-5 VDC	0.9-1.0 VDC	5-5.25 VDC	10 K Ω min
0-10 VDC	0 VDC	10-10.5 VDC	10 K Ω min

Resolution: 15 bit analog to digital converter
Output Regulation: 0.02% for full load change
Output Settling Time: 0.1 sec. (stable to 99.9%)
Isolation Breakdown Voltage: 1000 VAC
Temperature Effect: $\pm 0.01\%$ of span/ $^\circ\text{C}$

Solid State Relay (Triac) Output

Rating: 1A / 240 VAC
Inrush Current: 20A for 1 cycle
Min. Load Current: 50 mA rms
Max. Off-state Leakage: 3 mA rms
Max. On-state Voltage: 1.5 VAC rms
Insulation Resistance: 1000 Megohms minimum at 500 VDC
Dielectric Strength: 2500 VAC for 1 minute

Output 2 / Alarm 1 — Programmable

Alarm 1 Relay: Form A, (NO)
 Maximum rating: 240 VAC, 2 Amp

Alarm Functions: Dwell timer
 Deviation High / Low Alarm
 Deviation Band High / Low Alarm
 Process High / Low Alarm
 Sensor Break Alarm

Alarm Mode: Normal, Latching, Hold, Latching / Hold

Dwell Timer: 0 - 4553.6 minutes

Interface: RS-485 (up to 247 units)

Protocol: Modbus Protocol – RTU mode

Address: 1-247 **Baud Rate:** 0.3 - 38.4 Kbits/sec
Data Bits: 7 or 8 bits **Parity Bit:** None, Even or Odd
Stop Bit: 1 or 2 bits **Communication Buffer:** 160 bytes

User Interface

Single 4-digit LED Displays: 0.4" / 10 mm **Keypad:** 4 keys

Programming Port: For automatic setup, calibration and testing

Control Mode

Output 1: Reverse (heating) or direct (cooling) action

Output 2: PID cooling control, cooling P band 50-300% of PB, dead band -36.0 to 36.0% of PB

On-Off: 0.1 - 90.0 $^\circ\text{F}$ hysteresis control (P band = 0)

P or PD: 0 - 100.0% offset adjustment

PID: Fuzzy logic modified

Proportional band: 0.1 - 900 $^\circ\text{F}$

Integral time: 0 - 1000 seconds

Derivative time: 0 - 360 seconds

Cycle Time: 0.1 - 90 seconds

Manual Control: Heat (MV1) and Cool (MV2)

Auto-tuning: Cold start and warm start

Failure Mode: Auto-transfer to manual mode with sensor break or A-D converter damage

Ramping Control: 0 - 900 $^\circ\text{F}/\text{min}$ or 0 - 900 $^\circ\text{F}/\text{hr}$ ramp rate

Environmental and Physical

Operating Temperature: 14 to 122 $^\circ\text{F}$ (-10 to 50 $^\circ\text{C}$)

Storage Temperature: -40 to 140 $^\circ\text{F}$ (-40 to 60 $^\circ\text{C}$)

Humidity: 0 to 90% RH, non-condensing

Dielectric Strength: 2000 VAC, 50/60 Hz for 1 minute

Dimensions: 1-7/8 \times 1-7/8 \times 3-3/4" (48 \times 48 \times 94 mm) H \times W \times D
 Depth behind panel: 3-3/8" (86 mm)

Panel Cutout: 1-25/32 \times 1-25/32" (45 \times 45 mm) H \times W

Weight: 0.31 lb. (140 grams)

Approval Standards

Safety: UL61010C-1, CSA C22.2 No. 24-93
 EN61010-1 (IEC1010-1)

EMC: EN61326

Protective Class: Front Panel: IP30
 Housing and Terminals: IP 20

Rear Terminal Connections

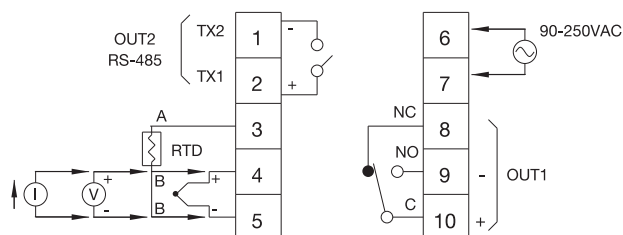

Stock and Common Part Numbers

(Power Input: 90-250 VAC)

Part Number	Signal Input	Out 1	Out 2 / Alarm1
TEC15001	tc	relay	none
TEC15002	tc	relay	relay
TEC15003	tc	4-20 mA	none
TEC15004	tc	DC pulse	none
TEC15005	RTD	relay	none
TEC15006	RTD	DC pulse	none
TEC15007	RTD	DC pulse	relay

Model TEC-9100 1/16 DIN Temperature Controller



Configurable for 4 Programmable Outputs and optional NEMA 4X/IP65 Front Panel!

Agency Approvals: RoHS



Design Features

- * 1/16 DIN size – 48 mm × 48 mm
- * Fuzzy Logic PID Autotune heat & cool control
- * Short panel depth – only 4-1/8" (105 mm) required
- * Universal input, field configurable (Type J T/C default, PT100, mA, V) with high accuracy 18-bit D-A
- * Highly versatile – 6 types of output available
- * Output 2 can be programmed as output or alarm
- * Universal input power – 90-250 VAC or 11-26 VAC/VDC
- * Highly accurate universal input
- * Optional NEMA 4X/IP65 front panel
- * Bumpless transfer to manual mode during sensor failure
- * Wide variety of alarm mode selections
- * Optional RS-232 or RS-485 communications interface
- * Bright 0.40" (10 mm) red LED process display 0.31" (8 mm) green LED setpoint display
- * High performance at a very low price

Power Input BOX 1

- 4 = 90-264 VAC
- 5 = 11-26 VAC / VDC
- 9 = Other

Hardware Code: TEC-9100-

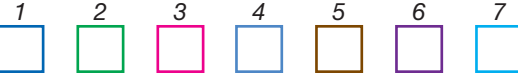

A Part Number based on the hardware code and any software pre-programming will be issued at time of order.

Standard lead time is stock to 2 weeks.

Signal Input – Universal, can be programmed in the field for item 5 or 6 BOX 2

- 5 = Thermocouple: *J, K, T, E, B, R, S, N, L 0-60mV
- 6 = RTD: *PT100 DIN, PT100 JIS
- 7 = 0-1 VDC
- 8 = *0-5, 1-5 VDC
- A = 0-10 VDC
- B = *4-20, 0-20 mA
- 9 = Other * indicates default value

Alarm BOX 5

- 0 = None
- 1 = Relay: 2A / 240 VAC, SPDT
- 9 = Other

Communication BOX 6

- 0 = None
- 1 = RS-485 Interface
- 2 = RS-232 Interface
- 3 = Retransmission 4-20 mA (default), 0-20 mA
- 4 = Retransmission 1-5 VDC (default), 0-5 VDC
- 5 = Retransmission 0-10 VDC
- 9 = Other

Case Options BOX 7

- 0 = Panel mount standard
- 1 = Panel mount with NEMA 4X/IP65 front panel
- 2 = DIN rail mount adapter

Output 1 BOX 3

- 1 = Relay: 2A / 240 VAC
- 2 = Pulse dc for SSR drive: 5 VDC (30 mA max)
- 3 = Isolated, 4-20 mA (default), 0-20 mA
- 4 = Isolated, VDC, 1-5 (default), 0-5, 0-1
- 5 = Isolated, VDC, 0-10
- 6 = Triac-SSR output 1A / 240 VAC
- C = Pulse DC for SSR drive: 14 VDC (40 mA max)
- 9 = Other

Output 2 BOX 4

- 0 = None
- 1 = Relay: 2A / 240 VAC
- 2 = Pulse DC for SSR drive: 5 VDC (30 mA max)
- 3 = Isolated, 4-20 mA (default), 0-20 mA
- 4 = Isolated VDC, 1-5 (default), 0-5, 0-1
- 5 = Isolated VDC, 0-10
- 6 = Triac-SSR output 1A / 240 VAC
- 7 = Isolated 20V @ 25 mA DC, Output Power Supply
- 8 = Isolated 12V @ 40 mA DC, Output Power Supply
- 9 = Isolated 5V @ 80 mA DC, Output Power Supply
- C = Pulse DC for SSR drive: 14 VDC (40 mA max)
- A = Other



Note: Detailed information on features common to digital microprocessor-based TEC temperature controls and the complete Table of Input Range and Accuracy can be found on page 13-46.

Power Input

Standard: 90-250 VAC, 47-63 Hz, 10 VA, 5W maximum
Optional: 11-26 VAC / VDC, 10 VA, 5W maximum

Signal Input

Resolution: 18 bits **Sampling Rate:** 5 samples / second
Accuracy: $\pm 0.24\%$ of span typical
Maximum Rating: -2 VDC minimum, 12 VDC maximum (1 minute for mA input)
Temperature Effect: $\pm 1.5 \mu\text{V} / ^\circ\text{C}$ for all inputs except mA input
 $\pm 3.0 \mu\text{V} / ^\circ\text{C}$ for mA input
Sensor Lead Resistance Effect: T/C: $0.2 \mu\text{V}/\text{ohm}$
 3-wire RTD: $2.6^\circ\text{C}/\text{ohm}$ of resistance difference of two leads
Burn-out Current: 200nA
Common Mode Rejection Ratio (CMRR): 120 dB
Normal Mode Rejection Ratio (NMRR): 55 dB
Sensor Break Detection: Sensor open for TC, RTD and mV inputs; sensor short for RTD input; below 1 mA for 4-20 mA input; below 0.25V for 1-5V input; unavailable for other inputs
Sensor Break Response Time: Within 4 seconds for TC, RTD and mV inputs; 0.1 second for 4-20 mA and 1-5 V inputs

Output 1 / Output 2

Relay Rating: 240 VAC, 2 Amp
Pulsed Voltage: Source voltage 5V, Current limiting resistance 66 Ω

Linear Output — Characteristics

Type	Zero	Span	Load
Tolerance	Tolerance	Capacity	
4-20 mA	3.6-4.0 mA	20-21 mA	500 Ω max
0-20 mA	0 mA	20-21 mA	500 Ω max
0-5 VDC	0 VDC	5-5.25 VDC	10 K Ω min
1-5 VDC	0.9-1.0 VDC	5-5.25 VDC	10 K Ω min
0-10 VDC	0 VDC	10-10.5 VDC	10 K Ω min

Resolution: 15 bit analog to digital converter
Output Regulation: 0.02% for full load change
Output Settling Time: 0.1 sec. (stable to 99.9%)
Isolation Breakdown Voltage: 1000 VAC
Temperature Effect: $\pm 0.01\%$ of span/ $^\circ\text{C}$
Solid State Relay (Triac) Output
Rating: 1A / 240 VAC
Inrush Current: 20A for 1 cycle
Min. Load Current: 50 mA rms
Max. Off-state Leakage: 3 mA rms
Max. On-state Voltage: 1.5 VAC rms
Insulation Resistance: 1000 Megohms minimum at 500 VDC
Dielectric Strength: 2500 VAC for 1 minute

Rear Terminal Connections

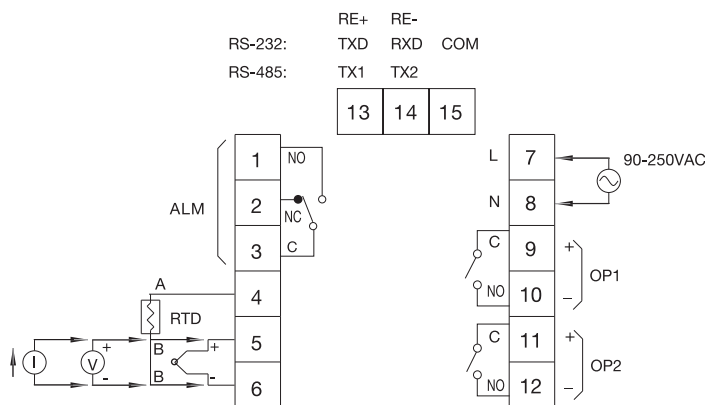

Output 2 / Alarm 1 — Programmable

Alarm 1 Relay: Form A, (NO)
 Maximum rating: 240 VAC, 2 Amp
Alarm Functions: Dwell timer
 Deviation High / Low Alarm
 Deviation Band High / Low Alarm
 Process High / Low Alarm
 Sensor Break Alarm
Alarm Mode: Normal, Latching, Hold, Latching / Hold
Dwell Timer: 0 - 4553.6 minutes

Data Communications

Interface: RS-232 (1 unit), RS-485 (up to 247 units)
Protocol: Modbus Protocol – RTU mode
Address: 1-247 **Baud Rate:** 0.3 - 38.4 Kbits/sec
Data Bits: 7 or 8 bits **Parity Bit:** None, Even or Odd
Stop Bit: 1 or 2 bits **Communication Buffer:** 160 bytes

User Interface

Dual 4-digit LED Display: 0.40" (10 mm) Red Process Display
 0.31" (8 mm) Green Setpoint Display

Keypad: 4 keys

Programming Port: For automatic setup, calibration and testing

Control Mode

Output 1: Reverse (heating) or direct (cooling) action
Output 2: PID cooling control, cooling P band 50-300% of PB, dead band -36.0 to 36.0% of PB
On-Off: 0.1 - 90.0 $^\circ\text{F}$ hysteresis control (P band = 0)
P or PD: 0 - 100.0% offset adjustment
PID: Fuzzy logic modified
Proportional band: 0.1 - 900 $^\circ\text{F}$
Integral time: 0 - 1000 seconds
Derivative time: 0 - 360 seconds
Cycle Time: 0.1 - 90 seconds
Manual Control: Heat (MV1) and Cool (MV2)
Auto-tuning: Cold start and warm start
Failure Mode: Auto-transfer to manual mode with sensor break or A-D converter damage
Ramping Control: 0 - 900 $^\circ\text{F}/\text{min}$ or 0 - 900 $^\circ\text{F}/\text{hr}$ ramp rate

Environmental and Physical

Operating Temperature: 14 to 122 $^\circ\text{F}$ (-10 to 50 $^\circ\text{C}$)
Humidity: 0 to 90% RH, non-condensing
Dielectric Strength: 2000 VAC, 50/60 Hz for 1 minute
Dimensions: 1-7/8 \times 1-7/8 \times 4-9/16" (48 \times 48 \times 116 mm) H \times W \times D
 Depth behind panel: 4-1/8" (105 mm)
Panel Cutout: 1-25/32 \times 1-25/32" (45 \times 45 mm) H \times W
Weight: 0.33 lb. (150 grams)

Approval Standards

Safety: UL61010C-1, CSA C22.2 No. 24-93
 EN61010-1 (IEC1010-1)
EMC: EN61326
Protective Class: Front Panel: IP50, optional NEMA 4X/IP65
 Housing and Terminals: IP 20

Stock and Common Part Numbers

(Power Input: 90-250 VAC, no data com, no NEMA 4X)

Part Number	Signal Input	Output 1	Output 2	Alarm
TEC14001	tc	relay	relay	none
TEC14002	tc	relay	none	none
TEC14003	tc	relay	none	relay
TEC14004	tc	4-20 mA	none	none
TEC14005	RTD	relay	none	none
TEC14006	RTD	relay	none	relay
TEC14007	RTD	DC pulse	none	none
TEC14008	RTD	DC pulse	none	relay

Model TEC-9090 1/16 DIN Temperature Controller



Dual Display, Configurable for 2 Programmable Outputs!

Design Features

- * 1/16 DIN size – 48 mm × 48 mm
- * Fuzzy Logic PID Autotune heat & cool control
- * Short panel depth – only 3-7/8" (86 mm) required
- * Universal input, field configurable (Type J T/C default, PT100, mA, V) with high accuracy 18-bit D-A
- * Highly versatile – 6 types of inputs available
- * Optional relay alarm output
- * Universal input power 90-264 VAC, 20-32 VAC/VDC or 10-18 VDC
- * Wide variety of alarm mode selections
- * Bright 0.40" (10 mm) red LED process display
0.31" (8 mm) green LED setpoint display
- * High performance at a low price

Agency Approvals



Hardware Code: TEC-9090- 1 2 3 4 5 0 7 0 9

A Part Number based on the hardware code and any software pre-programming will be issued at time of order.

Standard lead time is stock to 2 weeks.

Power Input BOX 1

- 4 = 90-264 VAC
- 5 = 20-32 VAC/VDC
- 6 = 10-18 VDC
- 9 = Other

Signal Input – (hardware jumper change between TC & RTD) BOX 2

- 5 = Thermocouple: Universal Configurable:
J, K, T, E, B, R, S, N (default: Type J)
- 6 = RTD: Universal Configurable: DIN or JIS
(default: alpha 0.00385/DIN)
- 9 = Other

Range code BOX 3

- 1 = Field configurable (default – max per input type)
- 9 = Other

Control Mode BOX 4

- 3 = Field Configurable
(default: PID reverse acting, °F)
- 9 = Other

Output 1 BOX 5

- 1 = Relay: 3A / 240 VAC
- 2 = Pulse DC for SSR drive: 20 VDC (20 mA max)
- 3 = 4-20 mA, linear (max load 500Ω)
- 4 = 0-20 mA, linear (max load 500Ω)
- 5 = 0-10 VDC, linear (min. impedance 10 KΩ)
- 6 = Triac-SSR output 1A / 240 VAC
- 9 = Other

Output 2 BOX 6

- 0 = None

Alarm BOX 7

- 0 = None
- 1 = Relay: 2A / 240 VAC, Field Configurable
- 9 = Other

Data Communications BOX 8

- 0 = None

Units – °F or °C BOX 9

- 1 = °F on faceplate
- 2 = °C on faceplate



Note: Detailed information on features common to digital microprocessor-based TEC temperature controls and the complete Table of Input Range and Accuracy can be found on page 13-46.



Power Input

Standard: 90-264 VAC, 47-63 Hz, 5VA, 5W maximum
Optional: 20-32 VAC/VDC, 5VA, 5W maximum or 10-18 VDC, 5W maximum

Signal Input

Accuracy: ±.24% of span typical
Cold Junction Compensation: 0.1°C /°C ambient typical
Sensor Break Detection: Protection mode configurable
External Resistance: 100 ohms maximum
Normal Mode Rejection: 60 dB
Common Mode Rejection: 120 dB
Sampling Rate: 5 samples / second

Output 1

Relay Rating: 240 VAC, 3 Amp
Pulsed Voltage: Source voltage 20V (20 mA max)
Current: 4 - 20 mA, at 500Ω max
Current: 0 - 20 mA, at 500Ω min
Voltage: 0 - 10 VDC, at 10 KΩ min
Solid State Relay (Triac) Output
Rating: 1A / 240 VAC
Inrush Current: 20A for 1 cycle
Min. Load Current: 50 mA rms
Dielectric Strength: 2500 VAC for 1 minute

Approval Standards

Safety: UL873, CSA22.2/142-87, IEC1010-1
EMC Emission: EN50081-1
EMC Immunity: EN50082-1
Protective Class: Front Panel: IP30
 Housing and Terminals: IP 20

Alarm – Programmable

Alarm Relay: Form A, (NO)
Maximum rating: 240 VAC, 3 Amp
Alarm Functions: Dwell timer
 Deviation High or Low Alarm
 Deviation Band High or Low Alarm
 Process High Alarm
 Sensor Break Alarm
Dwell Timer: 0 - 6553.5 minutes

User Interface

Dual 4-digit LED Display: 0.40" (10 mm) Red Process Display
 0.31" (8 mm) Green Setpoint Display
Keypad: 4 keys

Control Mode

Output 1: Reverse (heating) or direct (cooling) action
On-Off: 0 - 20% of span hysteresis control (P band = 0)
P or PD: 0 - 100.0% offset adjustment
PID: Fuzzy logic modified
Proportional band: 0.1 - 360°F (0 - 200°C)
Integral time: 0 - 3600 seconds
Derivative time: 0 - 1000 seconds
Cycle Time: 0 - 120 seconds
Auto-tuning: Cold start and warm start
Ramping Control: 0 - 360°F/min (200°C/min)

Environmental and Physical

Operating Temperature: 14 to 122°F (-10 to 50°C)
Humidity: 0 to 90% RH, non-condensing
Dielectric Strength: 2000 VAC, 50/60 Hz for 1 minute
Dimensions: 1-7/8 × 1-7/8 × 3-3/4" (48 × 48 × 94 mm) H×W×D
 Depth behind panel: 3-3/8" (86 mm)
Panel Cutout: 1-25/32 × 1-25/32" (45 × 45 mm) H×W
Weight: 0.37 lb. (170 grams)

Stock and Common Part Numbers (Power Input: 90-264 VAC)

Part Number	Signal Input	Out 1	Alarm
TEC11002	TC	relay	relay
TEC11001	TC	relay	none
TEC11007	TC	4-20 mA	none
TEC11003	TC	DC pulse	none
TEC11009	RTD	relay	none
TEC11010	RTD	DC pulse	none

Rear Terminal Connections

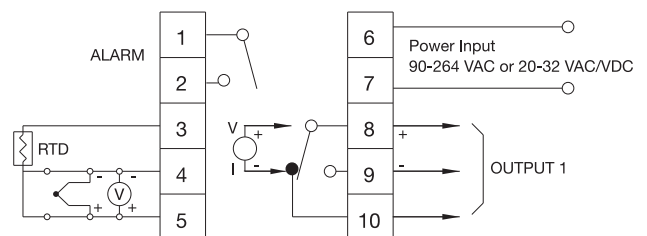

Model TEC-9300 1/16 DIN Temperature Controller



Configurable with 4 Programmable Outputs and Standard NEMA 4X/IP65 Front Panel!

Design Features

- * 1/16 DIN size – 48 mm × 48 mm
- * Fuzzy Logic PID Autotune heat and cool control
- * Short panel depth – only 3" (75 mm) required
- * Universal input, field configurable (Type J T/C default, PT100, mA, V) with high accuracy 18-bit D-A
- * Heater Break Alarm using 0-50 Amp current transformer
- * Output 2 can be programmed as output or alarm
- * NEMA 4X / IP65 gasketed front panel
- * Alarm 1 – programmable NO or NC relay
- * Universal input power, 90-264 VAC or 11-26 VAC/VDC
- * Bumpless transfer to manual mode during sensor failure
- * Power limiter output
- * Wide variety of alarm mode selections
- * RS-485 and RS-232 data communications interface
- * Bright 0.40" (10 mm) red LED process display, 0.31" (8 mm) green LED setpoint display
- * Fast input sample rate (5 samples/second)
- * Automatic programming
- * Differential control
- * "Soft-Start" ramp and dwell timer
- * Analog input for remote setpoint and current transformer
- * Event input for changing functions and setpoint
- * Hardware lockout plus remote lockout protection
- * Loop break alarm
- * Analog retransmission
- * DC power supply outputs
- * Tempco's most highly featured 1/16 DIN control



Hardware Code: TEC-9300- 1 2 3 4 5 6

A Part Number based on the hardware code and any software pre-programming will be issued at time of order.

Standard lead time is stock to 2 weeks.

Power Input BOX 1

- 4 = 90-264 VAC
- 5 = 11-26 VAC / VDC
- 9 = Other

Signal Input – Universal, can be programmed in the field BOX 2

- 1 = Input 1 – Universal input (factory default = tc type J) Thermocouple: J, K, T, E, B, R, S, N, L
RTD: PT100 DIN, PT100 JIS
Current: 4-20 mA, 0-20 mA
Voltage: VDC, 0-1, 0-5, 1-5, 0-10
- Input 2 – CT: 0 - 50A AC current Transformer (factory default)
Linear Input: 0-1V, 0-5V, 1-5V, 0-10V, 0-20mA, 4-20mA
- Input 3 – Event Input, not available if RS-232 is specified
- 9 = Other

Output 1 BOX 3

- 1 = Relay: 2A / 240 VAC
- 2 = Pulse DC for SSR drive: 5 VDC (30 mA max)
- 3 = Isolated, 4-20 mA (default), 0-20 mA
- 4 = Isolated, VDC, 1-5 (default), 0-5, 0-1
- 5 = Isolated, VDC, 0-10
- 6 = Triac-SSR output 1A / 240 VAC
- C = Pulse DC for SSR drive: 14 VDC (40 mA max)
- 9 = Other

Output 2 / Alarm 2 BOX 4

- 0 = None
- 1 = Relay: 2A / 240 VAC
- 2 = Pulse DC for SSR drive: 5 VDC (30 mA max)
- 3 = Isolated, 4-20 mA (default), 0-20 mA
- 4 = Isolated VDC, 1-5 (default), 0-5, 0-1
- 5 = Isolated VDC, 0-10
- 6 = Triac-SSR output 1A / 240 VAC
- 7 = Isolated 20V @ 25 mA DC, Output Power Supply
- 8 = Isolated 12V @ 40 mA DC, Output Power Supply
- 9 = Isolated 5V @ 80 mA DC, Output Power Supply
- C = Pulse DC for SSR drive: 14 VDC (40 mA max)
- A = Other

Alarm 1 BOX 5

- 0 = None
- 1 = Relay: 2A / 240 VAC (NO)
- 2 = Relay: 2A / 240 VAC (NC)
- 9 = Other

Communications BOX 6

- 0 = None
- 1 = RS-485 Interface
- 2 = RS-232 Interface
- 3 = Retransmission 4-20 mA (default), 0-20 mA
- 4 = Retransmission 1-5 VDC (default), 0-5 VDC
- 5 = Retransmission 0-10 VDC
- 9 = Other

Transformer for Heater Break Alarm

(0-50 Amp current)

Part Number: TEC99999

Specifications on page 13-47



Note: Detailed information on features common to digital microprocessor-based TEC temperature controls and the complete Table of Input Range and Accuracy can be found on page 13-46.



Power Input

Standard: 90-264 VAC, 47-63 Hz, 15 VA, 7W maximum
Optional: 11-26 VAC / VDC, 15 VA, 7W maximum

Signal Input

Input 1

Resolution: 18 bits **Sampling Rate:** 5 samples / second
Accuracy: ±.24% of span typical
Maximum Rating: -2 VDC minimum, 12 VDC maximum (1 minute for mA input)

Temperature Effect: ±1.5 μV / °C for all inputs except mA input
 ±3.0 μV / °C for mA input

Sensor Lead Resistance Effect: T/C: 0.2μV/ohm
 3-wire RTD: 2.6°C/ohm of resistance difference of two leads

Burn-out Current: 200nA

Common Mode Rejection Ratio (CMRR): 120 dB

Normal Mode Rejection Ratio (NMRR): 55 dB

Sensor Break Detection: Sensor open for TC, RTD and mV inputs; sensor short for RTD input; below 1 mA for 4-20 mA input; below 0.25V for 1-5V input; unavailable for other inputs

Sensor Break Response Time: Within 4 seconds for TC, RTD and mV inputs; 0.1 second for 4-20 mA and 1-5 V inputs

Input 2

Resolution: 18 bits **Sampling Rate:** 1.66 times per second

Sensor Break Response Time: 0.5 second

Types: **Current Transducer:** 0 to 50 Amp
 mA: -3 to 27 mA V: -1.3 to 11.5 VDC

Input 3

Event Input Functions: Select 2nd setpoint and/or PID, disable output 1 and/or output 2, remote lockout reset alarm 1 and/or alarm 2

Logic Low: -10V min., 0.8V max.

Logic High: 2V min., 10V max.

External Pull-Down Resistance: 400KΩ max

External Pull-Up Resistance: 1.5MΩ min

Output 1 or Output 2 / Alarm 2

Relay Rating: 240 VAC, 2 Amp

Pulsed Voltage: Source voltage 5V, Current limiting resistance 66Ω

Linear Output — Characteristics

Type	Tolerance	Zero Tolerance	Span Capacity	Load
4-20 mA		3.6-4.0 mA	20-21 mA	500Ω max
0-20 mA		0 mA	20-21 mA	500Ω max
0-5 VDC		0 VDC	5-5.25 VDC	10 KΩ min
1-5 VDC		0.9-1.0 VDC	5-5.25 VDC	10 KΩ min
0-10 VDC		0 VDC	10-10.5 VDC	10 KΩ min

Resolution: 15 bit analog to digital converter

Isolation Breakdown Voltage: 1000 VAC

Solid State Relay (Triac) Output

Rating: 1A / 240 VAC **Inrush Current:** 20A for 1 cycle

Min. Load Current: 50 mA rms

Max. Off-state Leakage: 3 mA rms

Max. On-state Voltage: 1.5 VAC rms

Insulation Resistance: 1000 Megohms minimum at 500 VDC

Dielectric Strength: 2500 VAC for 1 minute

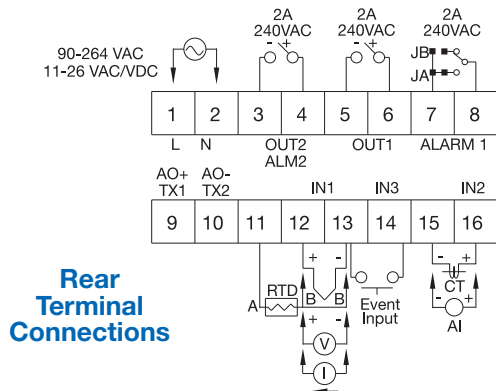

Rear Terminal Connections

Alarm 1 / Alarm 2

Alarm 1 Relay: Form A, (NO) Maximum rating: 240 VAC, 2 Amp

Alarm 1 Relay: Form A, (NC) Maximum rating: 240 VAC, 2 Amp

Alarm Functions:

Dwell timer PV1-PV2 High / Low Alarm
 Deviation Band High / Low Alarm Loop Break Alarm
 PV2 High / Low Alarm Sensor Break Alarm

Alarm Mode: Normal, Latching, Hold, Latching / Hold

Dwell Timer: 0 - 6553.5 minutes

Data Communications

Interface: RS-232 (1 unit), RS-485 (up to 247 units)

Protocol: Modbus Protocol – RTU mode

User Interface

Dual 4-digit LED Display: 0.40" (10 mm) Red Process Display

Keypad: 3 keys 0.31" (8 mm) Green Setpoint Display

Programming Port: For automatic setup, calibration and testing

Control Mode

Output 1: Reverse (heating) or direct (cooling) action

Output 2: PID cooling control, cooling P band 1-255% of PB

On-Off: 0.1 - 100.0°F hysteresis control (P band = 0)

P or PD: 0 - 100.0% offset adjustment

PID: Fuzzy logic modified

Proportional band: 0.1 - 900°F (500°C)

Integral: 0 - 1000 seconds **Derivative:** 0 - 360 seconds

Cycle Time: 0.1 - 100 seconds

Manual Control: Heat (MV1) and Cool (MV2)

Auto-tuning: Cold start and warm start

Failure Mode: Auto-transfer to manual mode with sensor break or A-D converter damage

Ramping Control: 0 - 900°F/min or 0 - 900°F/hr ramp rate

Power Limit: 0 - 100% for output 1 and output 2

Remote Setpoint: Programmable range for voltage or current input

Digital Filter: Time constant: settable from 0.2 to 60 seconds

Analog Retransmission

Analog Retransmission Functions: PV1, PV2, PV1-PV2, PV2-PV1, Setpoint, MV1, MV2, PV-SV deviation value

Output Signal: 4-20 / 0-20 mA, 0-1, 0-5, 1-5, 0-10 VDC

Accuracy: ±0.05 % of span, ±0.0025 %/°C

Environmental and Physical

Operating Temperature: 14 to 122°F (-10 to 50°C)

Storage Temperature: -40 to 140°F (-40 to 60°C)

Humidity: 0 to 90% RH, non-condensing

Dielectric Strength: 2000 VAC, 50/60 Hz for 1 minute

Dimensions: 2 × 2 × 3-1/2" (51 × 51 × 89 mm) H×W×D
 Depth behind panel: 3" (75 mm)

Panel Cutout: 1-25/32 × 1-25/32" (45 × 45 mm) H×W

Weight: 0.33 lb. (150 grams)

Approval Standards

Safety Standard: UL3121-1 and CSA: C22.2 No. 24-93
 EN61010-1 (IEC1010-1)

Protective Class: **Front panel:** NEMA 4X / IP65
Housing and Terminals: IP 20

EMC: EN61325

Stock and Common Part Numbers

(Power Input: 90-264 VAC, no data com)

Part Number	Signal Input	Out 1	Out 2/ Alarm 2	Alarm 1
TEC13001	tc-J	relay	none	none
TEC13002	tc-J	relay	relay	none
TEC13003	tc-J	4-20 mA	none	none
TEC13004	tc-J	4-20 mA	relay	none
TEC13005	tc-J	DC pulse	none	none
TEC13006	tc-J	DC pulse	relay	none

Temperature Controllers



Models TEC-410 & TEC-910

Model TEC-410 1/4 DIN & Model TEC-910 1/16 DIN High Limit Temperature Controls



*FM Approved
High Limit Control
with External Reset!*



Agency Approvals 910



Common Design Features

- * High Limit Control protects personnel, equipment and materials from over-temperature process conditions
- * Universal programmable thermocouple sensor input
- * Versatile – 2 types of outputs available
- * Highly accurate universal input with 18 bit analog to digital converter
- * FM approved for electric & gas heat systems
- * Bright 0.40" (10 mm) red LED process display
- * Short panel depth required
- * Output 2 can be programmed as output or input

TEC-410 Design Features

- * Universal input power – 90-250 VAC or 11-26 VAC/VDC
- * Event input for remote reset
- * Two programmable outputs
- * Optional RS-485 or RS-232 communications interface
- * Optional retransmission
- * Optional NEMA 4X/IP65 front face

TEC-910 Design Features

- * Universal input power – 90-264 VAC or 11-26 VAC/VDC
- * Optional event input for remote reset
- * Optional RS-485 communications interface
- * Output 2 can be programmed as output or input

Hardware Code: TEC-410-

A Part Number based on the hardware code and any software pre-programming will be issued at time of order.

Standard lead time is stock to 2 weeks.

Note: The use of solid state relays/contactors are highly discouraged for high limit safety circuits as solid state devices can fail in the closed position.

Hardware Code: TEC-910-

A Part Number based on the hardware code and any software pre-programming will be issued at time of order.

Standard lead time is stock to 2 weeks.

Power Input BOX 1

- 4** = 90-250 VAC (TEC-410)
90-264 VAC (TEC-910)
- 5** = 11-26 VAC / VDC

Signal Input – Universal, can be programmed in the field BOX 2

- 1** = Input 1 – Universal input (factory default = TC type J)
Thermocouple: J, K, T, E, B, R, S, N, L, C, P
mV: 0 to 60
- 9** = Other

Output 1 BOX 3

- 1** = Relay: 2A / 240 VAC, Form C
- 6** = Triac-SSR output 1A / 240 VAC
- 9** = Other

Output 2 BOX 4

For TEC-410

- 0** = None
- 1** = Relay: 2A / 240VAC, Form C
- 6** = Triac-SSR output 1A / 240VAC
- 7** = Isolated 20V @ 25mA DC, Output Power Supply
- 8** = Isolated 12V @ 40mA DC, Output Power Supply
- 9** = Isolated 5V @ 80mA DC, Output Power Supply

For TEC-910

- 0** = None
- 1** = Form A Relay: 2A / 240 VAC
- 6** = Triac Output 1A / 240VAC, SSR
- 7** = Isolated 20V @ 25mA DC Output Power Supply
- 8** = Isolated 12V @ 40mA DC Output Power Supply
- 9** = Isolated 5V @ 80mA DC Output Power Supply
- A** = RS-485
- B** = Event Input
- D** = Retransmit 4-20mA/0-20mA
- E** = Retransmit 1-5V/0-5V
- F** = Retransmit 0-10V
- H** = Special order

Communications BOX 5 (TEC-410 only)

- 0** = None
- 1** = RS-485 Interface
- 2** = RS-232 Interface
- 3** = Retransmission 4-20 mA, 0-20 mA
- 4** = Retransmission 1-5 VDC, 0-5 VDC
- 5** = Retransmission 0-10 VDC
- 9** = Other

Mounting Option BOX 6 (TEC-410 only)

- 0** = Standard Mounting, IP50
- 1** = NEMA 4X/IP65



Note: Detailed information on features common to digital microprocessor-based TEC temperature controls and the complete Table of Input Range and Accuracy can be found on page 13-46.

Power Input

Standard: (TEC-410) 90-250 VAC, 47-63 Hz, 10 VA, 5W maximum
(TEC-910) 90-264 VAC, 47-63 Hz, 10 VA, 5W maximum

Optional: 11-26 VAC / VDC, 10 VA, 5W maximum

Signal Input

Resolution: 18 bits **Sampling Rate:** 5 samples / second

Accuracy: $\pm 0.24\%$ of span typical

Maximum Rating: -2 VDC minimum, 12 VDC maximum (1 minute for mA input)

Temperature Effect: $\pm 1.5 \mu\text{V} / ^\circ\text{C}$ for all inputs except mA input
 $\pm 3.0 \mu\text{V} / ^\circ\text{C}$ for mA input

Sensor Lead Resistance Effect: T/C: $0.2 \mu\text{V}/\text{ohm}$

Burn-out Current: 200nA

Common Mode Rejection Ratio (CMRR): 120 dB

Normal Mode Rejection Ratio (NMRR): 55 dB

Sensor Break Detection: Sensor open for TC inputs

Sensor Break Response Time: Within 4 seconds for TC and mV inputs; 0.1 second for 4-20 mA and 1-5 V inputs

Output 1 / Output 2

Relay Rating: 240 VAC, 2 Amp

Solid State Relay (Triac) Output

Rating: 1A / 240 VAC **Inrush Current:** 20A for 1 cycle

Min. Load Current: 50 mA rms

Max. Off-state Leakage: 3 mA rms

Max. On-state Voltage: 1.5 VAC rms

Insulation Resistance: 1000 Megohms minimum at 500 VDC

Dielectric Strength: 2500 VAC for 1 minute

VDC Voltage Supply (Output 2 only)

20 VDC, $\pm 0.5\text{V}$, at 25 mA

12 VDC, $\pm 0.3\text{V}$, at 40 mA

5 VDC, $\pm 0.15\text{V}$, at 80 mA

Event Input (standard TEC-410, optional TEC-910)

Resolution: 18 bits

Logic Low: -10 VDC minimum, 0.8 VDC maximum

Logic High: 2 VDC minimum, 10 VDC maximum

Functions: Remote reset, remote lockout

Limit Control

Modes available: High Limit, Low Limit and High/Low Limit

Data Communications

Interface: RS-485 (up to 247 units), RS-232, *TEC-410 only*

Protocol: Modbus Protocol – RTU mode

Address: 1-247

Baud Rate: 0.3 - 38.4 Kbits/sec

Data Bits: 8 bits

Parity Bit: None, Even or Odd

Stop Bit: 1 or 2 bits

Communication Buffer: 50 bytes

User Interface

Single 4-digit LED Displays: 0.4" / 10 mm

Keypad: 4 keys

Programming Port: For automatic setup, calibration and testing

Environmental and Physical

Operating Temperature: 14 to 122°F (-10 to 50°C)

Humidity: 0 to 90% RH, non-condensing

Dielectric Strength: 2000 VAC, 50/60 Hz for 1 minute

Dimensions:

TEC-410: 3-3/4 × 3-3/4 × 2-9/16" (96 × 96 × 65 mm) H×W×D

Depth behind panel: 2" (53 mm)

Panel Cutout: 3-21/32" × 3-21/32" (93 × 93 mm) H×W

Weight: 0.55 lb. (250 grams)

TEC-910: 1-7/8 × 1-7/8 × 3-3/4" (48 × 48 × 94 mm) H×W×D

Depth behind panel: 3-3/8" (86 mm)

Panel Cutout: 1-25/32" × 1-25/32" (45 × 45 mm) H×W

Weight: 0.33 lb. (150 grams)

Approval Standards

Safety: FM Class 3545 (OCT. 1998)

CSA: C22.2 No. 24-93

EN61010-1 (IEC1010-1)

TEC-410: UL61010C-1

TEC-910: UL873

Protective Class: IP30 front panel, indoor use,
IP20 housing and terminals (with protective cover)

EMC: EN61326

TEC-410 Stock and Common Part Numbers (Power Input: 90-250 VAC)

Part Number	Signal Input	Out 1	Out 2
TEC51001	tc	relay	none
TEC51002	tc	relay	relay
TEC51005	tc	SSR-1A	none
TEC51006	tc	SSR-1A	relay

TEC-910 Stock and Common Part Numbers (Power Input: 90-264 VAC)

Part Number	Signal Input	Out 1	Prog. I/O
TEC16001	tc	relay	event input
TEC16003	tc	SSR-1A	event input
TEC16004	tc	relay	none
TEC16006	tc	SSR-1A	none

NOTE: See page 13-46 for features common to TEC digital microprocessor-based temperature controls and the complete Table of Input Range and Accuracy.

(800) 323-6859 • Email: sales@tempco.com

TEC-410 1/4 DIN Rear Terminal Connections

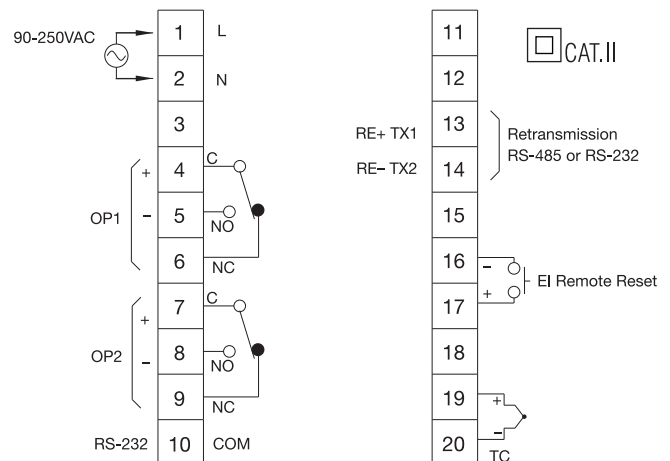

TEC-910 1/16 DIN Rear Terminal Connections

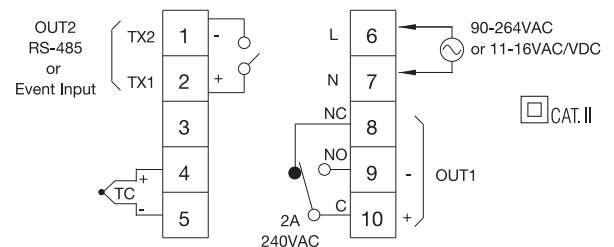

Temperature Controllers



Models TEC-4500 & TEC-9500

Model TEC-4500 1/4 DIN & Model TEC-9500 1/16 DIN Ramp & Soak Temperature Controls



Configurable for 5 Programmable Outputs

Configurable for 4 Programmable Outputs

Design Features

- * Ramp & Soak Programmable Control
- * Nine recipes (profiles) available using 64 segments maximum per recipe
- * Event Input – one of 8 functions can be chosen: start run mode, hold mode, abort recipe, manual mode, failure transfer, turn off, segment advance, select 2nd set of PID parameters
- * Event Output – 3 relays are available. Can be programmed to any segment or end of recipe
- * Analog Retransmission – optional mA or VDC transfer of PV or SV values
- * Highly accurate universal input with 18 bit analog to digital converter
- * Bright 0.40" (10mm) red LED process display
- * Fast sample rate – 200ms
- * Fuzzy Logic PID Autotune heat and cool control – 2 sets of values can be used
- * Optional RS-485 or RS-232 communications interface
- * Programming port available for PC connection allowing quick set-up
- * Lockout protection guards against unauthorized setting changes
- * Bumpless transfer allows continued temperature control if sensor fails
- * Universal input, field configurable (Type J T/C default, PT100, mA, V) with high accuracy 18-bit D-A
- * Short panel depth required



Note: Detailed information on features common to digital microprocessor-based TEC temperature controls and the complete Table of Input Range and Accuracy can be found on page 13-46.

Hardware Code: TEC-4500-

1	2	3	4	5	6	7	8
---	---	---	---	---	---	---	---

Hardware Code: TEC-9500-

1	2	3	4	5	0	7	8
---	---	---	---	---	---	---	---

Power Input BOX 1

- 4 = 90-250 VAC, 50-60 Hz
- 5 = 11-26 VAC / VDC

Signal Input – Universal, can be programmed in the field BOX 2

- 1 = Universal input (factory default = TC type J)
Thermocouple: J, K, T, E, B, R, S, N, L, C, P
RTD: PT100 DIN, PT100 JIS (0 to 60mV)
- 5 = Voltage: 0-10V, 0-5V, 1-5V, 0-1V
- 6 = DC Current: 0-20 mA (default), 4-20 mA
- 9 = Other

Output 1 BOX 3

- 1 = Relay: 2A / 240 VAC
- 2 = Pulse DC for SSR drive: 5 VDC (30 mA max)
- 3 = Isolated 4-20mA / 0-20 mA
- 4 = Isolated 1-5V / 0-5V/0-10VDC
- 6 = Triac-SSR output 1A / 240 VAC
- C = Pulse DC for SSR drive: 14 VDC (40 mA max)
- 9 = Other

Output 2 BOX 4

- 0 = None
- 1 = Relay: 2A / 240 VAC
- 2 = Pulse DC for SSR drive – 5 VDC (30 mA max)
- 3 = Isolated 4-20mA / 0-20 mA
- 4 = Isolated 1-5V / 0-5V/0-10V
- 6 = Triac-SSR output 1A / 240 VAC
- 7 = Isolated 20V @ 25 mA DC, Output Power Supply
- 8 = Isolated 12V @ 40 mA DC, Output Power Supply
- A = Isolated 5V @ 80 mA DC, Output Power Supply
- C = Pulsed voltage to drive SSR, 14V/40mA
- 9 = Other

Output 3 BOX 5

- 0 = None
- 1 = Relay: 2A / 240 VAC
- 2 = Pulse DC for SSR drive – 5 VDC (30 mA max)
- 6 = Triac-SSR output 1A / 240 VAC
- 7 = Isolated 20V @ 25 mA DC, Output Power Supply
- 8 = Isolated 12V @ 40 mA DC, Output Power Supply
- A = Isolated 5V @ 80 mA DC, Output Power Supply
- C = Pulsed voltage to drive SSR, 14V/40mA
- 9 = Other

Output 4 BOX 6 (TEC-4500 only)

- 0 = None
- 1 = Relay: 2A / 240 VAC
- 2 = Pulse DC for SSR drive – 5 VDC (30 mA max)
- 3 = Retransmission 4-20mA (default), 0-20 mA
- 4 = Retransmission 1-5 VDC (default)/ 0-5VDC, 0-10 VDC
- 6 = Triac-SSR output 1A / 240 VAC
- 7 = Isolated 20V @ 25 mA DC, Output Power Supply
- 8 = Isolated 12V @ 40 mA DC, Output Power Supply
- A = Isolated 5V @ 80 mA DC, Output Power Supply
- C = Pulsed voltage to drive SSR, 14V/40mA
- 9 = Other

A Part Number based on the hardware code and any software pre-programming will be issued at time of order.

Standard lead time is stock to 2 weeks.

CONTINUED

Temperature Controllers



Models TEC-905 & TEC-900 1/16 DIN

Model TEC-905 1/16 DIN Controller & Model TEC-900 1/16 DIN Indicator Only



Simple Setpoint and Display!



Display only!

Design Features

- * 1/16 DIN size – 48 mm × 48 mm
- * Short panel depth – only 3-3/8" (86 mm) required
- * Laser trimmed ASIC components
- * On-off or time proportional selections
- * Wide selection of output options
- * Universal power input, 90-264 VAC
- * Sensor break protection
- * Good performance at a very low price
- * Model TEC-905 control with pushwheel setpoint
- * Model TEC-900 indicator only

Agency Approvals



Temperature Controller
Hardware Code: TEC-905-

A Part Number based on the hardware code and any software pre-programming will be issued at time of order.

Standard lead time is stock to 2 weeks.

Temperature Indicator
Hardware Code: TEC-900-

A Part Number based on the hardware code and any software pre-programming will be issued at time of order.

Standard lead time is stock to 2 weeks.

Power Input BOX 1

4 = 90-264 VAC 50/60 Hz

Signal Input BOX 2

- 1** = Thermocouple: Type J
- 2** = Thermocouple: Type K
- 3** = RTD: 100 ohm PT, DIN 0.00385
- 4** = RTD: 100 ohm PT, JIS 0.00392
- 9** = Other

Control Mode BOX 4

(TEC-905 only)

- 1** = On - Off (used for valves & solenoids)
- 2** = Proportional (common for electric heaters)

Range code (TEC-905 only) BOX 3

- X** = 0 to 499°F **C** = 0 to 299°C
- V** = 0 to 999°F **E** = 0 to 499°C
- W** = 0 to 1999°F **H** = 0 to 999°C

Other ranges are available for large volume orders. Consult Tempco for more information.

Range code (TEC-900 only) BOX 3

- Thermocouple**
- A** = 0 to 1200°F – Type J
- B** = 0 to 600°C – Type J
- C** = 0 to 2000°F – Type K
- D** = 0 to 1100°C – Type K
- RTD**
- E** = -32 to 752°F
- F** = 0 to 400°C

Output 1 (TEC-905 only) BOX 5

- 1** = Relay: 5A / 240 VAC
- 2** = Pulse DC for SSR drive: 20 VDC (20 mA max)
- 3** = 4-20 mA, linear (max load 500 ohms)
- 4** = 0-20 mA, linear (max load 500 ohms)
- 5** = 0-10 VDC, linear (min. impedance 500K ohms)
- 9** = Other

Output 2 BOX 6

Alarm BOX 7

Communication BOX 8

0 = Not Available

Power Input

Standard: 90-264 VAC, 50/60 Hz, 5VA

Signal Input

Accuracy: $\pm 1.0\%$ of full scale at 77°F/25°C

Thermocouple: Type J or K

RTD: 3-wire Pt100 DIN or JIS

Sampling Rate: 3 samples / second

Cold Junction Compensation: $\pm 0.1^\circ\text{C} / 1^\circ\text{C}$

Common Mode Rejection Ratio (CMRR): 120 dB

Normal Mode Rejection Ratio (NMRR): 60 dB

Sensor Break Protection: Upscale

Output 1 (for TEC-905 only)

Relay Rating: 240 VAC, 5 Amp

SSR drive: Pulsed DC, 20 V at 20 mA maximum

Current: 4 - 20 mA, 0 - 20 mA, maximum load: 500Ω

Voltage: 0 - 10 VDC, minimum load 500KΩ

Control (for TEC-905 only)

Proportional Band: 2.2% of span

ON-OFF Hysteresis: 1% of span

Cycle time: 20 seconds for relay output, 1 second for pulsed voltage output, 0.02 second for linear current or voltage output

Control Action: Reverse Action

Approval Standards

Safety Standard: UL3121-1

Protective Class: Front panel: IP 30

Housing and Terminals: IP 20

EMC: EN61326

Adjustment (for TEC-905 only)

Setpoint: 3-digit or 4-digit pushwheel switch

Manual Reset: Adjustable up to 2.6% of span

Setpoint Resolution: ± 1 Least Significant Digit

Accuracy of Setpoint: $\pm 1\%$ of span

Repeatability of Setpoint: ± 1 Least Significant Digit

Display

Process Indicator: 3-1/2 digit, 0.4" / 10 mm red LED display

Output Status Indicator: Red LED lamp (for TEC-905 only)

Environmental and Physical

Operating Temperature: 32 to 122°F (0 to 50°C)

Humidity: 0 to 90% RH, non-condensing

Dielectric Strength: 2000 VAC, 50/60 Hz for 1 minute

Vibration: 10 - 55 Hz, amplitude 1mm

Shock: 200 m/s² (20g)

Dimensions: 1-7/8 × 1-7/8 × 3-3/4" (48 × 48 × 94 mm) H×W×D
Depth behind panel: 3-3/8" (86 mm)

Panel Cutout: 1-25/32" × 1-25/32" (45 × 45 mm) H×W

Weight: 0.42 lb. (190 grams)

Rear Terminal Connections

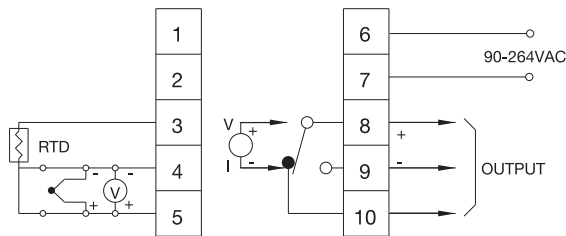

NOTE: Terminals 8, 9 and 10 are not used for Model TEC-900.

TEC-905 Stock and Common Part Numbers (Power Input: 90-264 VAC, Proportional Mode)

Part Number	Signal Input	Range	Output
TEC17511	J tc	0-999°F	relay
TEC17512	J tc	0-499°F	relay
TEC17513	K tc	0-1999°F	relay
TEC17514	K tc	0-999°F	relay
TEC17515	J tc	0-499°C	relay
TEC17516	J tc	0-299°C	relay
TEC17517	K tc	0-999°C	relay
TEC17518	K tc	0-499°C	relay
TEC17519	RTD	0-999°F	relay
TEC17520	RTD	0-499°C	relay

TEC-900 Stock and Common Part Numbers (Power Input: 90-264 VAC, Indicator Only)

Part Number	Signal Input	Range
TEC17021	J tc	0-1200°F
TEC17022	K tc	0-2000°F
TEC17023	J tc	0-600°C
TEC17024	K tc	0-1100°C
TEC17025	RTD	32-752°F
TEC17026	RTD	0-400°C

Temperature Controllers



Models TEC-901 & TEC-902 1/16 DIN

Models TEC-901 & TEC-902 (with Hi-Low LED Indicators) 1/16 DIN Temperature Controllers



Non-Indicating Control!



Shows Process Temperature Deviation with Hi/Low LEDs!

Design Features

- * 1/16 DIN size – 48 mm × 48 mm
- * Short panel depth – only 3-3/8" (86 mm) required
- * Laser trimmed ASIC components
- * On-off or time proportional selections
- * Wide selection of output options
- * Dial/Potentiometer setpoint
- * Sensor break protection
- * Good performance at a very low price
- * Model TEC-901 temperature control
- * Model TEC-902 temperature control with process temperature Hi-Low LED indicators

Agency Approvals



Hardware Code: TEC-901- 1 2 3 4 5 0 0 0

A Part Number based on the hardware code and any software pre-programming will be issued at time of order.

Standard lead time is stock to 2 weeks.

With Hi-Low LEDs

Hardware Code: TEC-902- 1 2 3 4 5 0 0 0

A Part Number based on the hardware code and any software pre-programming will be issued at time of order.

Standard lead time is stock to 2 weeks.

Power Input BOX 1

- 1** = 100-130 VAC, 50/60 Hz
- 2** = 200-240 VAC, 50/60 Hz

Signal Input BOX 2

- 1** = Thermocouple: Type J
- 2** = Thermocouple: Type K
- 3** = RTD: 100 ohm PT, DIN 0.00385
- 4** = RTD: 100 ohm PT, JIS 0.00392
- 9** = Other

Standard Range Code BOX 3

- 4** = 0 to 300°C **C** = 50 to 550°F
- 6** = 0 to 600°C **E** = 50 to 850°F

Below available for large volume orders. Consult Tempco for more information.

- 2** = 0 to 100°C **A** = 50 to 200°F
- 3** = 0 to 200°C **B** = 50 to 400°F
- 5** = 0 to 400°C **D** = 50 to 750°F
- 7** = 0 to 800°C **F** = 50 to 1100°F
- 8** = 0 to 1200°C **G** = 50 to 1400°F
- 9** = Other **H** = 0 to 2200°F

Control Mode BOX 4

- 1** = On - Off (used for valves & solenoids)
- 2** = Proportional (common for electric heaters)

Output 1 BOX 5

- 1** = Relay: 5A / 240 VAC
- 2** = Pulse DC for SSR drive: 20 VDC (20 mA max)
- 3** = 4-20 mA, linear (max load 500 ohms)
- 4** = 0-20 mA, linear (max load 500 ohms)
- 5** = 0-10 VDC, linear (min. impedance 500K ohms)
- 9** = Other

Output 2 BOX 6

Alarm BOX 7

Communication BOX 8

- 0** = Not Available

Power Input

100 - 130 VAC, 50/60 Hz, 5VA
 200 - 240 VAC, 50/60 Hz, 5VA

Signal Input

Accuracy: $\pm 2.0\%$ of full scale at 77°F/25°C
 Thermocouple: Type J or K
 RTD: 3-wire Pt100 DIN or JIS
 Sampling Rate: 3 samples / second
 Cold Junction Compensation: $\pm 0.1^\circ\text{C} / 1^\circ\text{C}$
 Common Mode Rejection Ratio (CMRR): 120 dB
 Normal Mode Rejection Ratio (NMRR): 60 dB
 Sensor Break Protection: Upscale

Output 1

Relay Rating: 240 VAC, 5 Amp
 SSR drive: Pulsed DC, 20 V at 20 mA maximum
 Current Loop: 4 - 20 mA, 0 - 20 mA, maximum load: 500Ω
 Voltage: 0 - 10 VDC, minimum load 500KΩ

Control

Proportional Band: 2.2% of span
 ON-OFF Hysteresis: 1% of span
 Cycle time: 20 seconds for relay output, 1 second for pulsed voltage output, 0.02 second for linear current or voltage output
 Control Action: Reverse Action

Approval Standards

Safety Standard: UL3121-1
 Protective Class: Front panel: IP 30
 Housing and Terminals: IP 20
 EMC: EN61326

Adjustment

Setpoint: Single turn wirewound potentiometer
 Setpoint Resolution: 0.2% of span
 Accuracy of Setpoint: $\pm 2\%$ of span
 Repeatability of Setpoint: $\pm 0.1\%$ of span

Display

Process Indicator: TEC-902: Hi/Lo LED indicators
 TEC-901: None

Status Indicator: ON (red) LED lamp, OFF (green) LED lamp

Environmental and Physical

Operating Temperature: 32 to 122°F (0 to 50°C)
 Humidity: 0 to 90% RH, non-condensing
 Dielectric Strength: 2000 VAC, 50/60 Hz for 1 minute
 Vibration: 10 - 55 Hz, amplitude 1 mm
 Shock: 200 m/s² (20g)
 Dimensions: 1-7/8 × 1-7/8 × 3-3/4" (48 × 48 × 94 mm) H×W×D
 Depth behind panel: 3-3/8" (86 mm)
 Panel Cutout: 1-25/32" × 1-25/32" (45 × 45 mm) H×W
 Weight: 0.42 lb. (190 grams)

Rear Terminal Connections

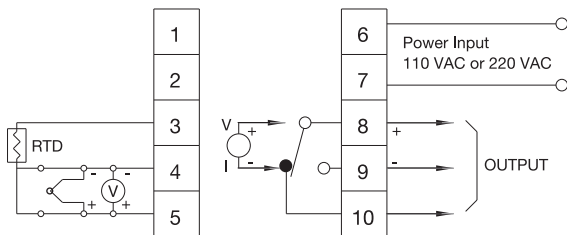

Non-Indicating TEC-901 Stock and Common Part Numbers (Power Input: 200-240 VAC, Proportional mode)

Part Number	Signal Input	Range	Output
TEC17101	J tc	50-850°F	relay
TEC17102	J tc	50-550°F	relay
TEC17103	K tc	50-850°F	relay
TEC17104	K tc	50-550°F	relay
TEC17105	RTD	50-550°F	relay
TEC17106	J tc	0-300°C	relay
TEC17107	J tc	0-600°C	relay
TEC17108	K tc	0-300°C	relay
TEC17109	K tc	0-600°C	relay

With Hi/Low LEDs TEC-902 Stock and Common Part Numbers (Power Input: 200-240 VAC, Proportional mode)

Part Number	Signal Input	Range	Output
TEC17201	J tc	50-850°F	relay
TEC17202	J tc	50-550°F	relay
TEC17203	K tc	50-850°F	relay
TEC17204	K tc	50-550°F	relay
TEC17205	RTD	50-550°F	relay
TEC17206	J tc	0-300°C	relay
TEC17207	J tc	0-600°C	relay
TEC17208	K tc	0-600°C	relay
TEC17209	RTD	0-300°C	relay

Model TEC-8100 1/8 DIN Temperature Controller



**Configurable for
4 Programmable
Outputs and optional
NEMA 4X/IP65
Front Panel!**

Agency Approvals



Design Features

- * 1/8 DIN size – 96 mm × 48 mm
- * Fuzzy Logic PID Autotune heat and cool control
- * Short panel depth – only 2-9/16" (65 mm) required
- * Universal input, field configurable (Type J T/C default, PT100, mA, V) with high accuracy 18-bit D-A
- * Highly versatile – 6 types of inputs available
- * Output 2 can be used for cooling function
- * Universal input power – 90-250 VAC or 11-26 VAC/VDC
- * Optional NEMA 4X/IP65 front panel
- * Bumpless transfer to manual mode during sensor failure
- * Wide variety of alarm mode selections
- * Optional RS-232 or RS-485 communications interface
- * Bright 0.40" (10 mm) red LED process display, 0.31" (8 mm) green LED setpoint display
- * High performance at a very low price

Power Input BOX 1

- 4 = 90-250 VAC
- 5 = 11-26 VAC / VDC
- 9 = Other

Hardware Code: TEC-8100-



A Part Number based on the hardware code and any software pre-programming will be issued at time of order.

Standard lead time is stock to 2 weeks.

Signal Input – Universal, can be programmed in the field for item 5 or 6 BOX 2

- 5 = Thermocouple: *J, K, T, E, B, R, S, N, L
0-60 mV
 - 6 = RTD: *PT100 DIN, PT100 JIS
 - 7 = 0-1 VDC
 - 8 = *0-5, 1-5 VDC
 - A = 0-10 VDC
 - B = *4-20, 0-20 mA
 - 9 = Other
- * indicates default value

Alarm BOX 5

- 0 = None
- 1 = Relay: 2A / 240 VAC, SPDT
- 9 = Other

Output 1 BOX 3

- 1 = Relay: 2A / 240 VAC
- 2 = Pulse DC for SSR drive: 5 VDC (30 mA max)
- 3 = Isolated, 4-20 mA (default), 0-20 mA
- 4 = Isolated, VDC, 1-5 (default), 0-5, 0-1
- 5 = Isolated, VDC, 0-10
- 6 = Triac-SSR output 1A / 240 VAC
- C = Pulse DC for SSR drive: 14 VDC (40 mA max)
- 9 = Other

Communication BOX 6

- 0 = None
- 1 = RS-485 Interface
- 2 = RS-232 Interface
- 3 = Retransmission 4-20 mA (default), 0-20 mA
- 4 = Retransmission 1-5 VDC (default), 0-5 VDC
- 5 = Retransmission 0-10 VDC
- 9 = Other

Output 2 BOX 4

- 0 = None
- 1 = Relay: 2A / 240 VAC
- 2 = Pulse DC for SSR drive: 5 VDC (30 mA max)
- 3 = Isolated, 4-20 mA (default), 0-20 mA
- 4 = Isolated VDC, 1-5 (default), 0-5, 0-1
- 5 = Isolated VDC, 0-10
- 6 = Triac-SSR output 1A / 240 VAC
- 7 = Isolated 20V @ 25 mA DC, Output Power Supply
- 8 = Isolated 12V @ 40 mA DC, Output Power Supply
- 9 = Isolated 5V @ 80 mA DC, Output Power Supply
- C = Pulse DC for SSR drive: 14 VDC (40 mA max)
- A = Other

NEMA 4X / IP65 BOX 7

- 0 = No
- 1 = Yes



Note: Detailed information on features common to digital microprocessor-based TEC temperature controls and the complete Table of Input Range and Accuracy can be found on page 13-46.



Power Input

Standard: 90-250 VAC, 47-63 Hz, 12 VA, 5W maximum
Optional: 11-26 VAC / VDC, 12 VA, 5W maximum

Signal Input

Resolution: 18 bits **Sampling Rate:** 5 samples / second
Accuracy: ±.24% of span typical
Maximum Rating: -2 VDC minimum, 12 VDC maximum (1 minute for mA input)
Temperature Effect: ±1.5 μV / °C for all inputs except mA input ±3.0 μV / °C for mA input

Sensor Lead Resistance Effect: T/C: 0.2μV/ohm
 3-wire RTD: 2.6°C/ohm of resistance difference of two leads

Burn-out Current: 200nA

Common Mode Rejection Ratio (CMRR): 120 dB

Normal Mode Rejection Ratio (NMRR): 55 dB

Sensor Break Detection: Sensor open for TC, RTD and mV inputs; sensor short for RTD input; below 1 mA for 4-20 mA input; below 0.25V for 1-5V input; unavailable for other inputs

Sensor Break Response Time: Within 4 seconds for TC, RTD and mV inputs; 0.1 second for 4-20 mA and 1-5 V inputs

Output 1 / Output 2

Relay Rating: 240 VAC, 2 Amp

Pulsed Voltage: Source voltage 5V, Current limiting resistance 66Ω

Linear Output — Characteristics

Type	Tolerance	Zero Tolerance	Span Capacity	Load
4-20 mA		3.6-4.0 mA	20-21 mA	500Ω max
0-20 mA		0 mA	20-21 mA	500Ω max
0-5 VDC		0 VDC	5-5.25 VDC	10 KΩ min
1-5 VDC		0.9-1.0 VDC	5-5.25 VDC	10 KΩ min
0-10 VDC		0 VDC	10-10.5 VDC	10 KΩ min

Resolution: 15 bit analog to digital converter

Output Regulation: 0.0% for full load change

Output Settling Time: 0.1 sec. (stable to 99.9%)

Isolation Breakdown Voltage: 1000 VAC

Temperature Effect: ±0.01 % of span/°C

Solid State Relay (Triac) Output

Rating: 1A / 240 VAC

Inrush Current: 20A for 1 cycle

Min. Load Current: 50 mA rms

Max. Off-state Leakage: 3 mA rms

Max. On-state Voltage: 1.5 VAC rms

Insulation Resistance: 1000 Megohms minimum at 500 VDC

Dielectric Strength: 2500 VAC for 1 minute

Alarm 1 — Programmable

Alarm 1 Relay: Form A, (NO)

Maximum rating: 240 VAC, 2 Amp

Alarm Functions: Dwell timer

Deviation High / Low Alarm
 Deviation Band High / Low Alarm
 Process High / Low Alarm
 Sensor Break Alarm

Alarm Mode: Normal, Latching, Hold, Latching / Hold

Dwell Timer: 0 - 4553.6 minutes

Data Communications

Interface: RS-232 (1 unit), RS-485 (up to 247 units)

Protocol: Modbus Protocol – RTU mode

Address: 1-247

Baud Rate: 0.3 - 38.4 Kbits/sec

Data Bits: 7 or 8 bits

Parity Bit: None, Even or Odd

Stop Bit: 1 or 2 bits

Communication Buffer: 160 bytes

User Interface

Dual 4-digit LED Display: 0.40" (10 mm) Red Process Display
 0.31" (8 mm) Green Setpoint Display

Keypad: 4 keys

Programming Port: For automatic setup, calibration and testing

Control Mode

Output 1: Reverse (heating) or direct (cooling) action

Output 2: PID cooling control, cooling P band 50-300% of PB

On-Off: 0.1 - 90°F hysteresis control (P band = 0)

P or PD: 0 - 100.0% offset adjustment

PID: Fuzzy logic modified

Proportional band: 0.1 - 900°F

Integral time: 0 - 1000 seconds

Derivative time: 0 - 360 seconds

Cycle Time: 0.1 - 90 seconds

Manual Control: Heat (MV1) and Cool (MV2)

Auto-tuning: Cold start and warm start

Failure Mode: Auto-transfer to manual mode with sensor break or A-D converter damage

Ramping Control: 0 - 900°F/min or 0 - 900°F/hr ramp rate

Environmental and Physical

Operating Temperature: 14 to 122°F (-10 to 50°C)

Storage Temperature: -40 to 140°F (-40 to 60°C)

Humidity: 0 to 90% RH, non-condensing

Dielectric Strength: 2000 VAC, 50/60 Hz for 1 minute

Dimensions: 3-3/4 × 1-7/8 × 3-1/8" (96 × 48 × 80 mm) H×W×D
 Depth behind panel: 2-9/16" (65 mm)

Panel Cutout: 3-5/8" × 1-25/32" (92 × 45 mm) H×W

Weight: 0.46 lb. (210 grams)

Approval Standards

Safety Standard: UL61010C-1 and CSA C22.2 No. 24-93
 EN61010-1 (IEC1010-1)

Protective Class: **Front panel:** IP 50, optional NEMA 4X/IP65
Housing and Terminals: IP 20

EMC: EN61326

Stock and Common Part Numbers

(Power Input: 90-250 VAC, no data com, no NEMA 4X)

Part Number	Signal Input	Out 1	Out 2	Alarm
TEC34001	tc	relay	none	none
TEC34002	tc	relay	relay	relay
TEC34003	tc	4-20 mA	none	none
TEC34004	tc	DC pulse	none	none
TEC34005	RTD	relay	none	none
TEC34006	RTD	DC pulse	none	none
TEC34007	RTD	DC pulse	relay	none
TEC34008	RTD	DC pulse	relay	relay

Rear Terminal Connections

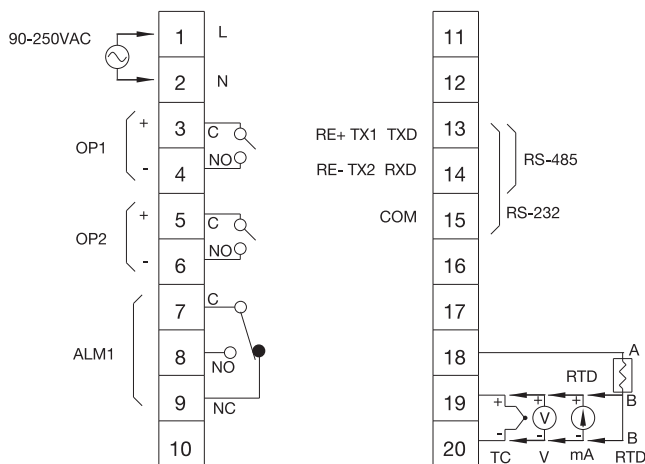

Temperature Controllers



Model TEC-8300 1/8 DIN

Model TEC-8300 1/8 DIN Temperature Controller



Configurable for
5 Programmable
Outputs!

Agency Approvals



Design Features

- * 1/8 DIN size – 48 mm × 96 mm
- * Fuzzy Logic PID Autotune heat and cool control
- * Short panel depth – only 2-9/16" (65 mm) required
- * Universal input, field configurable (Type J T/C default, PT100, mA, V) with high accuracy 18-bit D-A
- * Heater Break Alarm using 0-50 Amp current transformer
- * Output 2 can be programmed as cooling output only
- * 2 optional alarms – programmable NO or NC relay
- * Wide variety of alarm mode selections
- * Bumpless transfer to manual mode during sensor failure
- * Universal input power, 90-264 VAC
- * Power limiter output
- * RS-485 and RS-232 data communications interface
- * Bright 0.40" (10 mm) red LED process display, 0.31" (8 mm) green LED setpoint display stabilized with a digital filter if required
- * Fast input sample rate (5 samples/second)
- * Automatic programming
- * Differential control
- * "Soft-Start" ramp and dwell timer
- * Analog input for remote setpoint and current transformer
- * Event input for changing functions and setpoint
- * Hardware lockout plus remote lockout protection
- * Loop break alarm
- * Analog retransmission
- * DC power supply outputs
- * Tempco's most highly featured 1/8 DIN control

Power Input BOX 1

- 4 = 90-264 VAC
- 5 = 11-26 VAC / VDC
- 9 = Other

Signal Input – Universal, can be programmed in the field BOX 2

- 1 = Input 1 – Universal input (factory default = tc type J)
Thermocouple: J, K, T, E, B, R, S, N, L
RTD: PT100 DIN, PT100 JIS
Current: 4-20 mA, 0-20 mA
Voltage: VDC, 0-1, 0-5, 1-5, 0-10
- Input 2 – CT: 0 - 50A AC current Transformer (factory default)
Linear Input: 0-1V, 0-5V, 1-5V, 0-10V, 0-20mA, 4-20mA
- Input 3 – Event Input
- 9 = Other

Output 1 BOX 3

- 1 = Relay: 2A / 240 VAC
- 2 = Pulse DC for SSR drive: 5 VDC (30 mA max)
- 3 = Isolated, 4-20 mA (default), 0-20 mA
- 4 = Isolated, VDC, 1-5 (default), 0-5, 0-1
- 5 = Isolated, VDC, 0-10
- 6 = Triac-SSR output 1A / 240 VAC
- C = Pulse DC for SSR drive: 14 VDC (40 mA max)
- 9 = Other

Output 2 BOX 4

- 0 = None
- 1 = Relay: 2A / 240 VAC
- 2 = Pulse DC for SSR drive: 5 VDC (30 mA max)
- 3 = Isolated, 4-20 mA (default), 0-20 mA
- 4 = Isolated VDC, 1-5 (default), 0-5, 0-1
- 5 = Isolated VDC, 0-10
- 6 = Triac-SSR output 1A / 240 VAC
- 7 = Isolated 20V @ 25 mA DC, Output Power Supply
- 8 = Isolated 12V @ 40 mA DC, Output Power Supply
- 9 = Isolated 5V @ 80 mA DC, Output Power Supply
- C = Pulse DC for SSR drive: 14 VDC (40 mA max)
- A = Other

Hardware Code: TEC-8300-



A Part Number based on the hardware code and any software pre-programming will be issued at time of order.

Standard lead time is stock to 2 weeks.

Alarm 1 BOX 5

- 0 = None
- 1 = Relay: 2A/240 VAC, SPDT
- 9 = Other

Alarm 2 BOX 6

- 0 = None
- 1 = Relay: 2A/240 VAC, SPST
- 9 = Other

Communications BOX 7

- 0 = None
- 1 = RS-485 Interface
- 2 = RS-232 Interface
- 3 = Retransmission 4-20 mA (default), 0-20 mA
- 4 = Retransmission 1-5 VDC (default), 0-5 VDC
- 5 = Retransmission 0-10 VDC
- 9 = Other

**Transformer for
Heater Break Alarm**

(0-50 Amp current)

Part Number: TEC99999

Specifications on page 13-47



Note: Detailed information on features common to digital microprocessor-based TEC temperature controls and the complete Table of Input Range and Accuracy can be found on page 13-46.

View Product Inventory @ www.tempco.com

Power Input

Standard: 90-264 VAC, 47-63 Hz, 15 VA, 7W maximum
Optional: 11-26 VAC / VDC, 15 VA, 7W maximum

Signal Input

Input 1

Resolution: 18 bits **Sampling Rate:** 5 samples / second
Accuracy: ±.24% of span typical
Maximum Rating: -2 VDC minimum, 12 VDC maximum (1 minute for mA input)

Temperature Effect: ±1.5 μV / °C for all inputs except mA input
 ±3.0 μV / °C for mA input

Sensor Lead Resistance Effect: T/C: 0.2μV/ohm
 3-wire RTD: 2.6°C/ohm of resistance difference of two leads
Burn-out Current: 200nA

Common Mode Rejection Ratio (CMRR): 120 dB

Normal Mode Rejection Ratio (NMRR): 55 dB

Sensor Break Detection: Sensor open for TC, RTD and mV inputs; sensor short for RTD input; below 1 mA for 4-20 mA input; below 0.25V for 1-5V input; unavailable for other inputs

Sensor Break Response Time: Within 4 seconds for TC, RTD and mV inputs; 0.1 second for 4-20 mA and 1-5 V inputs

Input 2

Resolution: 18 bits **Sampling Rate:** 1.66 times per second

Sensor Break Response Time: 0.5 second

Types: **Current Transducer:** 0 to 50 Amp
 mA: -3 to 27 mA **V:** -1.3 to 11.5 VDC

Input 3

Event Input Functions: Select 2nd setpoint, and/or PID, disable output 1 and/or output 2, remote lockout, reset alarm 1 and/or alarm 2

Output 1 or Output 2

Relay Rating: 240 VAC, 2 Amp

Pulsed Voltage: Source voltage 5V, Current limiting resistance 66Ω

Linear Output — Characteristics

Type	Tolerance	Zero Tolerance	Span Capacity	Load
4-20 mA		3.6-4.0 mA	20-21 mA	500Ω max
0-20 mA		0 mA	20-21 mA	500Ω max
0-5 VDC		0 VDC	5-5.25 VDC	10 KΩ min
1-5 VDC		0.9-1.0 VDC	5-5.25 VDC	10 KΩ min
0-10 VDC		0 VDC	10-10.5 VDC	10 KΩ min

Resolution: 15 bit analog to digital converter

Isolation Breakdown Voltage: 1000 VAC

Solid State Relay (Triac) Output

Rating: 1A / 240 VAC **Inrush Current:** 20A for 1 cycle

Min. Load Current: 50 mA rms

Max. Off-state Leakage: 3 mA rms

Max. On-state Voltage: 1.5 VAC rms

Insulation Resistance: 1000 Megohms minimum at 500 VDC

Dielectric Strength: 2500 VAC for 1 minute

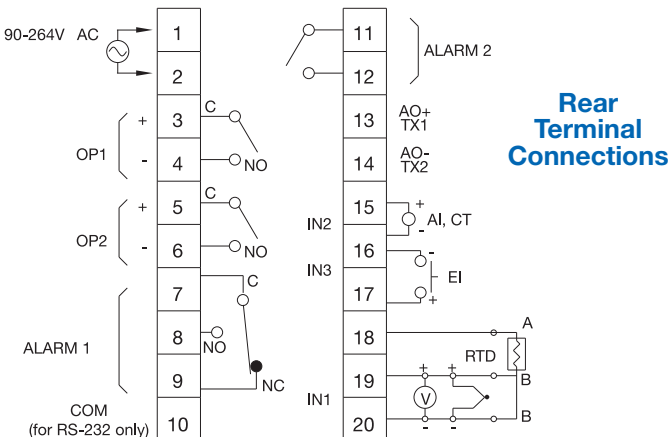

Alarm 1 / Alarm 2

Relay: 2 Amp, 240 VAC **Alarm 1:** SPDT **Alarm 2:** SPST (NO)

Alarm Functions:

Dwell timer PV1-PV2 High / Low Alarm
 Deviation Band High / Low Alarm Loop Break Alarm
 PV2 High / Low Alarm Sensor Break Alarm

Alarm Mode: Normal, Latching, Hold, Latching / Hold

Dwell Timer: 0 - 6553.5 minutes

Data Communications

Interface: RS-232 (1 unit), RS-485 (up to 247 units)

Protocol: Modbus Protocol – RTU mode

User Interface

Dual 4-digit LED Display: 0.40" (10 mm) Red Process Display

Keypad: 3 keys 0.31" (8 mm) Green Setpoint Display

Programming Port: For automatic setup, calibration and testing

Control Mode

Output 1: Reverse (heating) or direct (cooling) action

Output 2: PID cooling control, cooling P band 1 - 255% of PB

On-Off: 0.1 - 100.0°F hysteresis control (P band = 0)

P or PD: 0 - 100.0% offset adjustment

PID: Fuzzy logic modified

Proportional band: 0.1 - 900°F (500°C)

Integral: 0 - 1000 seconds **Derivative:** 0 - 360 seconds

Cycle Time: 0.1 - 100 seconds

Manual Control: Heat (MV1) and Cool (MV2)

Auto-tuning: Cold start and warm start

Failure Mode: Auto-transfer to manual mode with sensor break or A-D converter damage

Ramping Control: 0 - 900°F/min or 0 - 900°F/hr ramp rate

Power Limit: 0 - 100% for output 1 and output 2

Remote Setpoint: Programmable range for voltage or current input

Digital Filter: Time constant: settable from 0.2 to 60 seconds

Analog Retransmission

Analog Retransmission Functions: PV1, PV2, PV1-PV2, PV2-PV1, Setpoint, MV1, MV2, PV-SV deviation value

Output Signal: 4-20 / 0-20 mA, 0-1, 0-5, 1-5, 0-10 VDC

Accuracy: ±0.05 % of span, ±0.0025 %/°C

Environmental and Physical

Operating Temperature: 14 to 122°F (-10 to 50°C)

Storage Temperature: -40 to 140°F (-40 to 60°C)

Humidity: 0 to 90% RH, non-condensing

Dielectric Strength: 2000 VAC, 50/60 Hz for 1 minute

Dimensions: 3-3/4 × 1-7/8 × 3-1/8" (96 × 48 × 80 mm) H×W×D
 Depth behind panel: 2-9/16" (65 mm)

Panel Cutout: 3-5/8" × 1-25/32" (92 × 45 mm) H×W

Weight: 0.49 lb. (220 grams)

Approval Standards

Safety: UL873, CSA C22.2 No. 24-93

EN61010-1 (IEC1010-1)

Protective Class: IP 20 housing & terminals with protective covers

EMC: EN61326

Stock and Common Part Numbers

(Power Input: 90-264 VAC, no Alarm 2, no data com)

Part Number	Signal Input	Out 1	Out 2	Alarm 1
TEC33001	tc	relay	none	relay
TEC33002	tc	relay	relay	none
TEC33003	tc	relay	relay	relay
TEC33004	tc	4-20 mA	none	none
TEC33005	tc	4-20 mA	none	relay
TEC33006	tc	DC pulse	none	none
TEC33007	tc	DC pulse	none	relay

Model TEC-805 1/8 DIN Temperature Controller



Simple Setpoint and Display!

Agency Approvals



Design Features

- * 1/8 DIN size – 48 mm × 96 mm
- * Short panel depth – only 2-9/16" (65 mm) required
- * Laser trimmed ASIC components
- * On-off or time proportional selection
- * Digital input by pushwheel switch
- * Digital display on 0.4" (10 mm)
- * Wide selection of output options
- * Universal power input, 90-264 VAC
- * Sensor break protection
- * Good performance at a very low price

Hardware Code: TEC-805- 1 2 3 4 5 0 7 8 0

A Part Number based on the hardware code and any software pre-programming will be issued at time of order.

Standard lead time is stock to 2 weeks.

Power Input BOX 1

4 = 90-264 VAC 50/60 Hz

Signal Input BOX 2

- 1** = Thermocouple: Type J
- 2** = Thermocouple: Type K
- 3** = RTD: 100 ohm PT, DIN 0.00385
- 4** = RTD: 100 ohm PT, JIS 0.00392
- 9** = Other

Range code BOX 3

- X** = 0 to 499°F **C** = 0 to 299°C
- V** = 0 to 999°F **E** = 0 to 499°C
- W** = 0 to 1999°F **H** = 0 to 999°C

Other ranges are available for large volume orders. Consult Tempco for more information.

Control Mode BOX 4

- 1** = On - Off (used for valves & solenoids)
- 2** = Proportional (common for electric heaters)

Output 1 BOX 5

- 1** = Relay: 5A / 240 VAC
- 2** = Pulse DC for SSR drive: 20 VDC (20 mA max)
- 3** = 4-20 mA, linear (max load 500 ohms)
- 4** = 0-20 mA, linear (max load 500 ohms)
- 5** = 0-10 VDC, linear (min. impedance 500K ohms)
- 9** = Other

Output 2 BOX 6

0 = Not Available

Alarm BOX 7

- 0** = None
- 1** = Relay: 2A / 240 VAC Deviation alarm

Communication BOX 8

0 = Not Available

Power Input

Standard: 90 - 264 VAC, 50/60 Hz, 5VA

Signal Input

Accuracy: $\pm 1.0\%$ of full scale at 77°F/25°C

Thermocouple: Type J or K

RTD: 3-wire Pt100 DIN or JIS

Sampling Rate: 3 samples per second

Cold Junction Compensation: $\pm 0.1^\circ\text{C} / 1^\circ\text{C}$

Common Mode Rejection Ratio (CMRR): 120 dB

Normal Mode Rejection Ratio (NMRR): 60 dB

Sensor Break Protection: Upscale

Output

Relay Rating: 240 VAC, 5 Amp

SSR drive: Pulsed DC, 20 V at 20 mA maximum

Current: 4 - 20 mA, 0 - 20 mA, maximum load: 500Ω

Voltage: 0 - 10 VDC, minimum load 500KΩ

Control

Proportional Band: 2.2% of span

ON-OFF Hysteresis: 1% of span

Cycle time: 20 seconds for relay output, 1 second for pulsed voltage output, 0.02 second for linear current or voltage output

Control Action: Reverse Action

Approval Standards

Safety Standard: UL3121-1

Protective Class: Front panel: IP 30

Housing and Terminals: IP 20

EMC: EN61326

Adjustment

Setpoint: 3-digit or 4-digit pushwheel switch

Manual Reset: Adjustable up to 2.6% of span

Setpoint Resolution: ± 1 Least Significant Digit

Accuracy of Setpoint: $\pm 1\%$ of span

Repeatability of Setpoint: ± 1 Least Significant Digit

Alarm

Type: Deviation $\pm 10\%$ of span **Relay:** 2A / 240 VAC

Display

Process Indicator: 3-1/2 digit, 0.4" / 10 mm red LED display

Output Status Indicator: Red LED lamp

Alarm Status Indicator: Red LED lamp

Environmental and Physical

Operating Temperature: 32 to 122°F (0 to 50°C)

Humidity: 0 to 90% RH, non-condensing

Dielectric Strength: 2000 VAC, 50/60 Hz for 1 minute

Vibration: 10 - 55 Hz, amplitude 1 mm

Shock: 200 m/s² (20g)

Dimensions: 3-3/4 × 1-7/8 × 3-1/8" (96 × 48 × 80 mm) H×W×D
Depth behind panel: 2-9/16" (65 mm)

Panel Cutout: 3-5/8" × 1-25/32" (92 × 45 mm) H×W

Weight: 0.42 lb. (190 grams)

Rear Terminal Connections

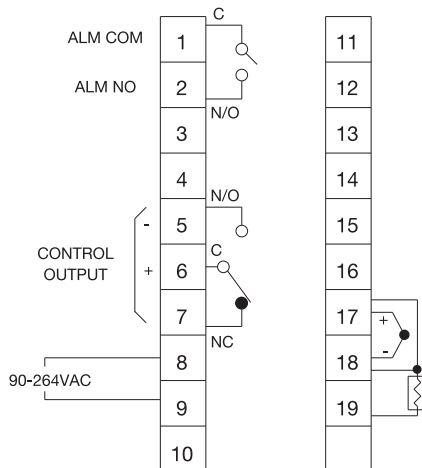

Stock and Common Part Numbers (Power Input: 90-264 VAC, Proportional Mode)

Part Number	Signal Input	Range	Output	Alarm
TEC35521	J tc	0-999°F	relay	none
TEC35522	J tc	0-499°F	relay	none
TEC35523	K tc	0-1999°F	relay	none
TEC35524	K tc	0-999°F	relay	none
TEC35525	J tc	0-499°C	relay	none
TEC35526	J tc	0-299°C	relay	none
TEC35527	K tc	0-999°C	relay	none
TEC35528	K tc	0-499°C	relay	none
TEC35529	RTD	0-999°F	relay	none
TEC35530	RTD	0-499°C	relay	none

Model TEC-7100 3/16 DIN Temperature Controller



Configurable for 4 Programmable Outputs and optional NEMA 4X/IP65 Front Panel!

Agency Approvals



Design Features

- * 3/16 DIN size – 72 mm × 72 mm
- * Fuzzy Logic PID Autotune heat and cool control
- * Short panel depth – only 2-9/16" (65 mm) required
- * Universal input, field configurable (Type J T/C default, PT100, mA, V) with high accuracy 18-bit D-A
- * Highly versatile – 6 types of inputs available
- * Output 2 can be used for cooling function
- * Universal input power – 90-250 VAC or 11-26 VAC/VDC
- * Optional NEMA 4X/IP65 front panel
- * Bumpless transfer to manual mode during sensor failure
- * Wide variety of alarm mode selections
- * Optional RS-485 communications interface
- * Bright 0.40" (10 mm) red LED process display
0.31" (8 mm) green LED setpoint display
- * High performance at a low price

Power Input BOX 1

- 4 = 90-250 VAC
- 5 = 11-26 VAC / VDC
- 9 = Other

Hardware Code: TEC-7100-



A Part Number based on the hardware code and any software pre-programming will be issued at time of order.

Standard lead time is stock to 2 weeks.

Signal Input— Universal, can be programmed in the field for item 5 or 6 BOX 2

- 5 = Thermocouple: *J, K, T, E, B, R, S, N, L
0-60mV
 - 6 = RTD: *PT100 DIN, PT100 JIS
 - 7 = 0-1 VDC
 - 8 = *0-5, 1-5 VDC
 - A = 0-10 VDC
 - B = *4-20, 0-20 mA
 - 9 = Other
- * indicates default value

Alarm BOX 5

- 0 = None
- 1 = Relay: 2A / 240 VAC, SPDT
- 9 = Other

Output 1 BOX 3

- 1 = Relay: 2A / 240 VAC
- 2 = Pulse DC for SSR drive: 5 VDC (30 mA max)
- 3 = Isolated, 4-20 mA (default), 0-20 mA
- 4 = Isolated, VDC, 1-5 (default), 0-5, 0-1
- 5 = Isolated, VDC, 0-10
- 6 = Triac-SSR output 1A / 240 VAC
- C = Pulse DC for SSR drive: 14 VDC (40 mA max)
- 9 = Other

Communication BOX 6

- 0 = None
- 1 = RS-485 Interface
- 3 = Retransmission 4-20 mA (default), 0-20 mA
- 4 = Retransmission 1-5 VDC (default), 0-5 VDC
- 5 = Retransmission 0-10 VDC
- 9 = Other

NEMA 4X / IP65 BOX 7

- 0 = No
- 1 = Yes

Output 2 BOX 4

- 0 = None
- 1 = Relay: 2A / 240 VAC
- 2 = Pulse DC for SSR drive: 5 VDC (30 mA max)
- 3 = Isolated, 4-20 mA (default), 0-20 mA
- 4 = Isolated VDC, 1-5 (default), 0-5, 0-1
- 5 = Isolated VDC, 0-10
- 6 = Triac-SSR output 1A / 240 VAC
- 7 = Isolated 20V @ 25 mA DC, Output Power Supply
- 8 = Isolated 12V @ 40 mA DC, Output Power Supply
- 9 = Isolated 5V @ 80 mA DC, Output Power Supply
- C = Pulse DC for SSR drive: 14 VDC (40 mA max)
- A = Other



Note: Detailed information on features common to digital microprocessor-based TEC temperature controls and the complete Table of Input Range and Accuracy can be found on page 13-46.

Power Input

Standard: 90-250 VAC, 47-63 Hz, 10 VA, 5W maximum
Optional: 11-26 VAC / VDC, 10 VA, 5W maximum

Signal Input

Resolution: 18 bits **Sampling Rate:** 5 samples / second
Accuracy: ±.24% of span typical
Maximum Rating: -2 VDC minimum, 12 VDC maximum (1 minute for mA input)

Temperature Effect: ±1.5 μV / °C for all inputs except mA input
 input ±3.0 μV / °C for mA input

Sensor Lead Resistance Effect: T/C: 0.2μV/ohm
 3-wire RTD: 2.6°C/ohm of resistance difference of two leads

Burn-out Current: 200nA

Common Mode Rejection Ratio (CMRR): 120 dB

Normal Mode Rejection Ratio (NMRR): 55 dB

Sensor Break Detection: Sensor open for TC, RTD and mV inputs; sensor short for RTD input; below 1 mA for 4-20 mA input; below 0.25V for 1-5V input; unavailable for other inputs

Sensor Break Response Time: Within 4 seconds for TC, RTD and mV inputs; 0.1 second for 4-20 mA and 1-5 V inputs

Output 1 / Output 2

Relay Rating: 240 VAC, 2 Amp

Pulsed Voltage: Source voltage 5V, Current limiting resistance 66Ω

Linear Output — Characteristics

Type	Tolerance	Zero Tolerance	Span Capacity	Load
4-20 mA		3.6-4.0 mA	20-21 mA	500Ω max
0-20 mA		0 mA	20-21 mA	500Ω max
0-5 VDC		0 VDC	5-5.25 VDC	10 KΩ min
1-5 VDC		0.9-1.0 VDC	5-5.25 VDC	10 KΩ min
0-10 VDC		0 VDC	10-10.5 VDC	10 KΩ min

Resolution: 15 bit analog to digital converter

Output Regulation: 0.02% for full load change

Output Settling Time: 0.1 sec. (stable to 99.9%)

Isolation Breakdown Voltage: 1000 VAC

Temperature Effect: ±0.01% of span/°C

Solid State Relay (Triac) Output

Rating: 1A / 240 VAC

Inrush Current: 20A for 1 cycle

Min. Load Current: 50 mA rms

Max. Off-state Leakage: 3 mA rms

Max. On-state Voltage: 1.5 VAC rms

Insulation Resistance: 1000 Megohms minimum at 500 VDC

Dielectric Strength: 2500 VAC for 1 minute

Approval Standards

Safety Standard: UL61010C-1
 CSA C22.2 No. 24-93
 EN61010-1 (IEC1010-1)

Protective Class: IP65 front panel with additional option
 IP 50 front panel without additional option, all indoor use
 IP 20 housing and terminals with protective cover

EMC: EN61326

Stock and Common Part Numbers

(Power Input: 90-250 VAC, no data com, no NEMA 4X)

Part Number	Signal Input	Out 1	Out 2	Alarm
TEC42001	tc	relay	none	none
TEC42002	tc	relay	relay	relay
TEC42003	tc	4-20 mA	none	none
TEC42004	tc	DC pulse	none	none
TEC42005	RTD	relay	none	none
TEC42006	RTD	DC pulse	none	none
TEC42007	RTD	DC pulse	relay	none
TEC42008	RTD	DC pulse	relay	relay

Alarm 1 — Programmable

Alarm 1 Relay: Form A, (NO)

Alarm 1 Relay: Form A, (NC), Maximum rating: 240 VAC, 2 Amp

Alarm Functions: Dwell timer
 Deviation High / Low Alarm
 Deviation Band High / Low Alarm
 Process High / Low Alarm
 Sensor Break Alarm

Alarm Mode: Normal, Latching, Hold, Latching / Hold

Dwell Timer: 0 - 4553.6 minutes

Data Communications

Interface: RS-485 (up to 247 units)

Protocol: Modbus Protocol – RTU mode

Address: 1-247 **Baud Rate:** 0.3 - 38.4 Kbits/sec

Data Bits: 7 or 8 bits **Parity Bit:** None, Even or Odd

Stop Bit: 1 or 2 bits **Communication Buffer:** 160 bytes

User Interface

Dual 4-digit LED Display: 0.40" (10 mm) Red Process Display
 0.31" (8 mm) Green Setpoint Display

Keypad: 4 keys

Programming Port: For automatic setup, calibration and testing

Control Mode

Output 1: Reverse (heating) or direct (cooling) action

Output 2: PID cooling control, cooling P band 50-300% of PB

On-Off: 0.1 - 100.0°F hysteresis control (P band = 0)

P or PD: 0 - 90.0% offset adjustment

PID: Fuzzy logic modified

Proportional band: 0.1 - 900°F

Integral time: 0 - 1000 seconds

Derivative time: 0 - 360 seconds

Cycle Time: 0.1 - 90 seconds

Manual Control: Heat (MV1) and Cool (MV2)

Auto-tuning: Cold start and warm start

Failure Mode: Auto-transfer to manual mode with sensor break or A-D converter damage

Ramping Control: 0 - 900°F/min or 0 - 900°F/hr ramp rate

Environmental and Physical

Operating Temperature: 14 to 122°F (-10 to 50°C)

Storage Temperature: -40 to 140°F (-40 to 60°C)

Humidity: 0 to 90% RH, non-condensing

Dielectric Strength: 2000 VAC, 50/60 Hz for 1 minute

Dimensions: 2-27/32 × 2-27/32 × 3" (72 × 72 × 78 mm) H×W×D
 Depth behind panel: 2-9/16" (65 mm)

Panel Cutout: 2-11/16" × 2-11/16" (68 × 68 mm) H×W

Weight: 0.44 lb. (200 grams)

Rear Terminal Connections

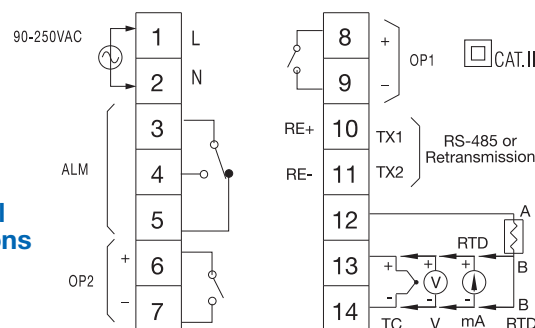

Model TEC-704 3/16 DIN Temperature Controller



Simple Setpoint and Display!

Design Features

- * 3/16 DIN size – 72 mm × 72 mm
- * Laser trimmed ASIC components
- * Short panel depth – only 2-9/16" (65 mm) required
- * On-off or time proportional selection
- * Digital display, 0.4" (10 mm) red LEDs
- * Wide selection of output options
- * High precision wire wound dial/potentiometer setpoint
- * Sensor break protection
- * Good performance at a very low price

Agency Approvals



Hardware Code: TEC-704- 1 2 3 4 5 0 7 0

A Part Number based on the hardware code and any software pre-programming will be issued at time of order.

Standard lead time is stock to 2 weeks.

Power Input BOX 1

4 = 90-264 VAC 50/60 Hz

Signal Input BOX 2

1 = Thermocouple: Type J
2 = Thermocouple: Type K
3 = RTD: 100 ohm PT, DIN 0.00385
4 = RTD: 100 ohm PT, JIS 0.00392
9 = Other

Standard Range Code BOX 3

4 = 0 to 300°C **C** = 50 to 550°F
6 = 0 to 600°C **E** = 50 to 850°F
F = 50 to 1100°F

Below available for large volume orders. Consult Tempco for more information.

2 = 0 to 100°C **A** = 50 to 200°F
3 = 0 to 200°C **B** = 50 to 400°F
5 = 0 to 400°C **D** = 50 to 750°F
7 = 0 to 800°C **G** = 50 to 1400°F
8 = 0 to 1200°C **H** = 0 to 2200°F
9 = Other

Control Mode BOX 4

1 = On - Off
2 = Proportional

Output 1 BOX 5

1 = Relay: 5A / 240 VAC
2 = Pulse DC for SSR drive: 20 VDC (20 mA max)
3 = 4-20 mA, linear (max load 500 ohms)
4 = 0-20 mA, linear (max load 500 ohms)
5 = 0-10 VDC, linear (min. impedance 500K ohms)
9 = Other

Output 2 BOX 6

0 = Not Available

Alarm BOX 7

0 = None
1 = Relay: 2A / 240 VAC Deviation alarm

Communication BOX 8

0 = Not Available

Power Input

Standard: 90 - 264 VAC, 50/60 Hz, 5VA

Signal Input

Accuracy: $\pm 1.0\%$ of full scale at 77°F/25°C

Thermocouple: Type J or K

RTD: 3-wire Pt100 DIN or JIS

Sampling Rate: 3 samples per second

Cold Junction Compensation: $\pm 0.1^\circ\text{C} / 1^\circ\text{C}$

Common Mode Rejection Ratio (CMRR): 120 dB

Normal Mode Rejection Ratio (NMRR): 60 dB

Sensor Break Protection: Upscale

Output

Relay Rating: 240 VAC, 5 Amp

SSR drive: Pulsed DC, 20 V at 20 mA maximum

Current: 4 - 20 mA, 0 - 20 mA, maximum load: 500Ω

Voltage: 0 - 10 VDC, minimum load: 500KΩ

Control

Proportional Band: 2.2% of span

ON-OFF Hysteresis: 1% of span

Cycle Time: 20 seconds for relay output, 1 second for pulsed voltage output, 0.02 second for linear current or voltage output

Control Action: Reverse Action

Approval Standards

Safety Standards: EN61326

Protective Class: Front panel: IP 30

Housing and Terminals: IP 20

Adjustment

Setpoint: Single turn wirewound potentiometer

Manual Reset: Adjustable up to 2.6% of span

Setpoint Resolution: 0.2% of span

Accuracy of Setpoint: $\pm 2\%$ of span

Repeatability of Setpoint: $\pm 0.1\%$ of span

Alarm

Type: Deviation $\pm 10\%$ of span Relay: 2A / 240 VAC

Display

Process Indicator: 3-1/2 digit, 0.4" / 10 mm red LED display

Output Status Indicator: Red LED lamp

Alarm Status Indicator: Red LED lamp

Environmental and Physical

Operating Temperature: 32 to 122°F (0 to 50°C)

Humidity: 0 to 90% RH, non-condensing

Dielectric Strength: 2000 VAC, 50/60 Hz for 1 minute

Vibration: 10 - 55 Hz, amplitude 1mm

Shock: 200 m/s² (20g)

Dimensions: 2-27/32 × 2-27/32 × 3" (72 × 72 × 78 mm) H×W×D
Depth behind panel: 2-9/16" (65 mm)

Panel Cutout: 2-11/16" × 2-11/16" (68 × 68 mm) H×W

Weight: 0.53 lb. (240 grams)

Rear Terminal Connections

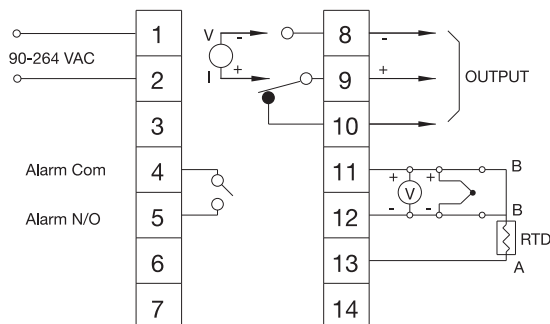

Stock and Common Part Numbers

(Power Input: 90-264 VAC, Proportional mode)

Part Number	Signal Input	Range	Output	Alarm
TEC43401	J tc	50-850°F	relay	none
TEC43402	J tc	50-550°F	relay	none
TEC43403	K tc	50-850°F	relay	none
TEC43404	K tc	50-550°F	relay	none
TEC43405	J tc	50-850°F	relay	relay
TEC43406	K tc	50-850°F	relay	relay
TEC43407	RTD	50-550°F	relay	none
TEC43408	RTD	50-550°F	relay	relay
TEC43409	J tc	0-300°C	relay	none
TEC43410	J tc	0-600°C	relay	none
TEC43411	J tc	0-300°C	relay	relay
TEC43412	K tc	0-300°C	relay	none
TEC43413	K tc	0-600°C	relay	relay
TEC43414	RTD	0-300°C	relay	none
TEC43415	RTD	0-600°C	relay	relay

Model TEC-4100 1/4 DIN Temperature Controller



Design Features

- * 1/4 DIN size – 96 mm × 96 mm
- * Fuzzy Logic PID Autotune heat and cool control
- * Short panel depth – only 2" (53 mm) required
- * Universal input, field configurable (Type J T/C default, PT100, mA, V) with high accuracy 18-bit D-A
- * Highly versatile – 6 types of inputs available
- * Output 2 can be used for cooling function
- * Universal input power – 90-250 VAC or 11-26 VAC/VDC
- * Optional NEMA 4X/IP65 front panel
- * Bumpless transfer to manual mode during sensor failure
- * Wide variety of alarm mode selections
- * Optional RS-232 or RS-485 communications interface
- * Bright 0.55" (14 mm) red LED process display and 0.40" (10 mm) green LED setpoint display
- * High performance at a low price

Configurable for 4 Programmable Outputs and NEMA 4X/IP65 Front Panel!

Agency Approvals



Power Input BOX 1

- 4 = 90-250 VAC
- 5 = 11-26 VAC / VDC
- 9 = Other

Hardware Code: TEC-4100-



A Part Number based on the hardware code and any software pre-programming will be issued at time of order.

Standard lead time is stock to 2 weeks.

Signal Input – Universal, can be programmed in the field for item 5 or 6 BOX 2

- 5 = Thermocouple: *J, K, T, E, B, R, S, N, L
0-60mV
- 6 = RTD: *PT100 DIN, PT100 JIS
- 7 = 0-1 VDC
- 8 = *0-5, 1-5 VDC
- A = 0-10 VDC
- B = *4-20, 0-20 mA
- 9 = Other * indicates default value

Alarm BOX 5

- 0 = None
- 1 = Relay: 2A / 240 VAC, SPDT
- 9 = Other

Output 1 BOX 3

- 1 = Relay: 2A / 240 VAC
- 2 = Pulse DC for SSR drive: 5 VDC (30 mA max)
- 3 = Isolated, 4-20 mA (default), 0-20 mA
- 4 = Isolated, VDC, 1-5 (default), 0-5, 0-1
- 5 = Isolated, VDC, 0-10
- 6 = Triac-SSR output 1A / 240 VAC
- C = Pulse DC for SSR drive: 14 VDC (40 mA max)
- 9 = Other

Communication BOX 6

- 0 = None
- 1 = RS-485 Interface
- 2 = RS-232 Interface
- 3 = Retransmission 4-20 mA (default), 0-20 mA
- 4 = Retransmission 1-5 VDC (default), 0-5 VDC
- 5 = Retransmission 0-10 VDC
- 9 = Other

Output 2 BOX 4

- 0 = None
- 1 = Relay: 2A / 240 VAC
- 2 = Pulse DC for SSR drive: 5 VDC (30 mA max)
- 3 = Isolated, 4-20 mA (default), 0-20 mA
- 4 = Isolated VDC, 1-5 (default), 0-5, 0-1
- 5 = Isolated VDC, 0-10
- 6 = Triac-SSR output 1A / 240 VAC
- 7 = Isolated 20V @ 25 mA DC, Output Power Supply
- 8 = Isolated 12V @ 40 mA DC, Output Power Supply
- 9 = Isolated 5V @ 80 mA DC, Output Power Supply
- C = Pulse DC for SSR drive: 14 VDC (40 mA max)
- A = Other

NEMA 4X / IP65 BOX 7

- 0 = No
- 1 = Yes



Note: Detailed information on features common to digital microprocessor-based TEC temperature controls and the complete Table of Input Range and Accuracy can be found on page 13-46.



Power Input

Standard: 90 - 250 VAC, 47-63 Hz, 10 VA, 5W maximum
Optional: 11 - 26 VAC / VDC, 10 VA, 5W maximum

Signal Input

Resolution: 18 bits **Sampling Rate:** 5 samples / second
Accuracy: $\pm 0.24\%$ of span typical
Maximum Rating: -2 VDC minimum, 12 VDC maximum (1 minute for mA input)
Temperature Effect: $\pm 1.5 \mu\text{V} / ^\circ\text{C}$ for all inputs except mA input $\pm 3.0 \mu\text{V} / ^\circ\text{C}$ for mA input

Sensor Lead Resistance Effect: T/C: $0.2 \mu\text{V}/\text{ohm}$
 3-wire RTD: $2.6^\circ\text{C}/\text{ohm}$ of resistance difference of two leads

Burn-out Current: 200nA

Common Mode Rejection Ratio (CMRR): 120 dB

Normal Mode Rejection Ratio (NMRR): 55 dB

Sensor Break Detection: Sensor open for TC, RTD and mV inputs; sensor short for RTD input; below 1 mA for 4-20 mA input; below 0.25V for 1-5V input; unavailable for other inputs

Sensor Break Response Time: Within 4 seconds for TC, RTD and mV inputs; 0.1 second for 4-20 mA and 1-5 V inputs

Output 1 / Output 2

Relay Rating: 240 VAC, 2 Amp

Pulsed Voltage: Source voltage 5V, Current limiting resistance 66 Ω

Linear Output — Characteristics

Type	Tolerance	Zero Tolerance	Span Capacity	Load
4-20 mA		3.6-4.0 mA	20-21 mA	500 Ω max
0-20 mA		0 mA	20-21 mA	500 Ω max
0-5 VDC		0 VDC	5-5.25 VDC	10 K Ω min
1-5 VDC		0.9-1.0 VDC	5-5.25 VDC	10 K Ω min
0-10 VDC		0 VDC	10-10.5 VDC	10 K Ω min

Resolution: 15 bit analog to digital converter

Output Regulation: 0.02% for full load change

Output Settling Time: 0.1 sec. (stable to 99.9%)

Isolation Breakdown Voltage: 1000 VAC

Temperature Effect: $\pm 0.01\%$ of span/ $^\circ\text{C}$

Solid State Relay (Triac) Output

Rating: 1A / 240 VAC

Inrush Current: 20A for 1 cycle

Min. Load Current: 50 mA rms

Max. Off-state Leakage: 3 mA rms

Max. On-state Voltage: 1.5 VAC rms

Insulation Resistance: 1000 Megohms minimum at 500 VDC

Dielectric Strength: 2500 VAC for 1 minute

Alarm 1 — Programmable

Alarm 1 Relay: Form A, (NO)

Maximum rating: 240 VAC, 2 Amp

Alarm Functions: Dwell timer

Deviation High / Low Alarm

Deviation Band High / Low Alarm

Process High / Low Alarm

Sensor Break Alarm

Alarm Mode: Normal, Latching, Hold, Latching / Hold

Dwell Timer: 0 - 4553.6 minutes

Data Communications

Interface: RS-232 (1 unit), RS-485 (up to 247 units)

Protocol: Modbus Protocol – RTU mode

Address: 1-247

Baud Rate: 0.3 - 38.4 Kbits/sec

Data Bits: 7 or 8 bits

Parity Bit: None, Even or Odd

Stop Bit: 1 or 2 bits

Communication Buffer: 160 bytes

User Interface

Dual 4-digit LED Display: 0.55" (14 mm) Red Process
 0.40" (10 mm) Green Setpoint

Keypad: 4 keys

Programming Port: For automatic setup, calibration and testing

Control Mode

Output 1: Reverse (heating) or direct (cooling) action

Output 2: PID cooling control, cooling P band 50-300% of PB

On-Off: 0.1 - 90.0 $^\circ\text{F}$ hysteresis control (P band = 0)

P or PD: 0 - 100.0% offset adjustment

PID: Fuzzy logic modified

Proportional band: 0.1 - 900 $^\circ\text{F}$

Integral time: 0 - 1000 seconds

Derivative time: 0 - 360 seconds

Cycle Time: 0.1 - 90 seconds

Manual Control: Heat (MV1) and Cool (MV2)

Auto-tuning: Cold start and warm start

Failure Mode: Auto-transfer to manual mode with sensor break or A-D converter damage

Ramping Control: 0 - 900 $^\circ\text{F}/\text{min}$ or 0 - 900 $^\circ\text{F}/\text{hr}$ ramp rate

Environmental and Physical

Operating Temperature: 14 to 122 $^\circ\text{F}$ (-10 to 50 $^\circ\text{C}$)

Storage Temperature: -40 to 140 $^\circ\text{F}$ (-40 to 60 $^\circ\text{C}$)

Humidity: 0 to 90% RH, non-condensing

Dielectric Strength: 2000 VAC, 50/60 Hz for 1 minute

Dimensions: 3-3/4 x 3-3/4 x 2-9/16" (96 x 96 x 65 mm) HxWxD
 Depth behind panel: 2" (53 mm)

Panel Cutout: 3-5/8" x 3-5/8" (92 x 92 mm) HxW

Weight: 0.55 lb. (250 grams)

Approval Standards

Safety Standard: UL61010C-1

CSA C22.2 No. 24-93

EN61010-1 (IEC1010-1)

Protective Class: IP 50 front panel standard, all indoor use.

NEMA 4X/IP65 front panel if specified.

IP 20 housing and terminals with protective cover.

EMC: EN61326

Stock and Common Part Numbers

(Power Input: 90-250 VAC, no data com, no NEMA 4X)

Part Number	Input	Out 1	Out 2	Alarm
TEC56001	tc	relay	none	relay
TEC56002	tc	relay	none	none
TEC56003	tc	4-20 mA	none	none
TEC56004	tc	dc pulse	none	none
TEC56005	RTD	relay	none	none
TEC56006	RTD	DC pulse	none	none
TEC56007	RTD	DC pulse	relay	none
TEC56008	RTD	DC pulse	none	relay

Rear Terminal Connections

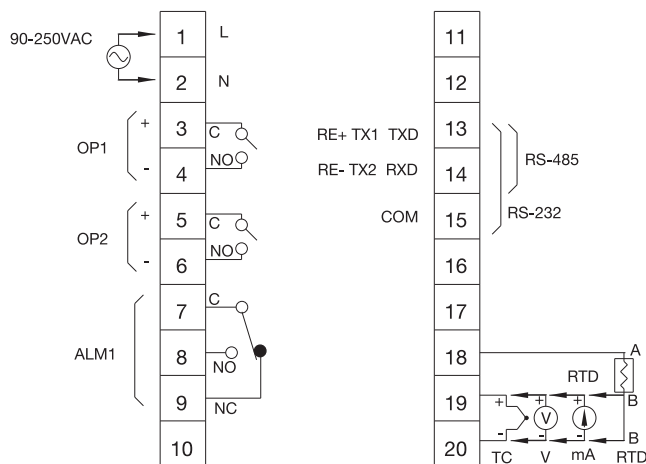

Model TEC-4300 1/4 DIN



Configurable for 5 Programmable Outputs!

Agency Approvals



Model TEC-4300 1/4 DIN Temperature Controller

Design Features

- * 1/4 DIN size – 96 mm × 96 mm
- * Fuzzy Logic PID Autotune heat and cool control
- * Short panel depth – only 2" (53 mm) required
- * Universal input, field configurable (Type J T/C default, PT100, mA, V) with high accuracy 18-bit D-A
- * Heater Break Alarm using 0-50 Amp current transformer
- * Output 2 can be programmed as cooling output only
- * 2 optional alarms – programmable NO or NC relay
- * Wide variety of alarm mode selections
- * Bumpless transfer to manual mode during sensor failure
- * Universal input power, 90-264 VAC or 11-26 VAC/VDC
- * Power limiter output
- * RS-485 and RS-232 data communications interface
- * Bright 0.55" (14 mm) red LED process display 0.40" (10 mm) and green LED setpoint display stabilized with a digital filter if required
- * Fast input sample rate (5 samples/second)
- * Differential control
- * "Soft-Start" ramp and dwell timer
- * Analog input for remote setpoint and current transformer
- * Event input for changing functions and setpoint
- * Hardware lockout plus remote lockout protection
- * Loop break alarm
- * Analog retransmission
- * DC power supply outputs
- * Tempco's most highly featured 1/4 DIN control

Power Input BOX 1

- 4 = 90-264 VAC
- 5 = 11-26 VAC / VDC
- 9 = Other

Signal Input – Universal, can be programmed in the field BOX 2

- 1 = Input 1 - Universal input (factory default = tc type J)
Thermocouple: J, K, T, E, B, R, S, N, L
RTD: PT100 DIN, PT100 JIS
Current: 4-20 mA, 0-20 mA
Voltage: VDC, 0-1, 0-5, 1-5, 0-10
- Input 2 - CT: 0 - 50A AC current Transformer (factory default)
Linear Input: 0-1V, 0-5V, 1-5V, 0-10V, 0-20mA, 4-20mA
- Input 3 - Event Input
- 9 = Other

Output 1 BOX 3

- 1 = Relay: 2A / 240 VAC
- 2 = Pulse DC for SSR drive: 5 VDC (30 mA max)
- 3 = Isolated, 4-20 mA (default), 0-20 mA
- 4 = Isolated, VDC, 1-5 (default), 0-5, 0-1
- 5 = Isolated, VDC, 0-10
- 6 = Triac-SSR output 1A / 240 VAC
- C = Pulse DC for SSR drive: 14 VDC (40 mA max)
- 9 = Other

Output 2 BOX 4

- 0 = None
- 1 = Relay: 2A / 240 VAC
- 2 = Pulse DC for SSR drive: 5 VDC (30 mA max)
- 3 = Isolated, 4-20 mA (default), 0-20 mA
- 4 = Isolated VDC, 1-5 (default), 0-5, 0-1
- 5 = Isolated VDC, 0-10
- 6 = Triac-SSR output 1A / 240 VAC
- 7 = Isolated 20V @ 25 mA DC, Output Power Supply
- 8 = Isolated 12V @ 40 mA DC, Output Power Supply
- 9 = Isolated 5V @ 80 mA DC, Output Power Supply
- C = Pulse DC for SSR drive: 14 VDC (40 mA max)
- A = Other

Hardware Code: TEC-4300-

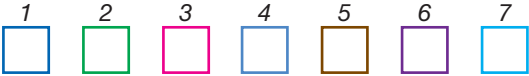

A Part Number based on the hardware code and any software pre-programming will be issued at time of order.

Standard lead time is stock to 2 weeks.

Alarm 1 BOX 5

- 0 = None
- 1 = Relay: 2A/240 VAC, SPDT
- 9 = Other

Alarm 2 BOX 6

- 0 = None
- 1 = Relay: 2A/240 VAC, SPST
- 9 = Other

Communications BOX 7

- 0 = None
- 1 = RS-485 Interface
- 2 = RS-232 Interface
- 3 = Retransmission 4-20 mA (default), 0-20 mA
- 4 = Retransmission 1-5 VDC (default), 0-5 VDC
- 5 = Retransmission 0-10 VDC
- 9 = Other

Transformer for Heater Break Alarm

(0-50 Amp current)

Part Number: TEC99999

Specifications on page 13-47



Note: Detailed information on features common to digital microprocessor-based TEC temperature controls and the complete Table of Input Range and Accuracy can be found on page 13-46.

View Product Inventory @ www.tempco.com

Power Input

Standard: 90 - 264 VAC, 47-63 Hz, 15 VA, 7W maximum
Optional: 11 - 26 VAC / VDC, 15 VA, 7W maximum

Signal Input

Input 1

Resolution: 18 bits **Sampling Rate:** 5 samples / second
Accuracy: $\pm 0.24\%$ of span typical
Maximum Rating: -2 VDC minimum, 12 VDC maximum (1 minute for mA input)

Temperature Effect: $\pm 1.5 \mu\text{V} / ^\circ\text{C}$ for all inputs except mA input
 $\pm 3.0 \mu\text{V} / ^\circ\text{C}$ for mA input

Sensor Lead Resistance Effect: T/C: $0.2 \mu\text{V}/\text{ohm}$
 3-wire RTD: $2.6^\circ\text{C}/\text{ohm}$ of resistance difference of two leads

Burn-out Current: 200nA

Common Mode Rejection Ratio (CMRR): 120 dB

Normal Mode Rejection Ratio (NMRR): 55 dB

Sensor Break Detection: Sensor open for TC, RTD and mV inputs; sensor short for RTD input; below 1 mA for 4-20 mA input; below 0.25V for 1-5V input; unavailable for other inputs

Sensor Break Response Time: Within 4 seconds for TC, RTD and mV inputs; 0.1 second for 4-20 mA and 1-5 V inputs

Input 2

Resolution: 18 bits **Sampling Rate:** 1.66 times per second

Sensor Break Response Time: 0.5 second

Types: **Current Transducer:** 0 to 50 Amp
 mA: -3 to 27 mA V: -1.3 to 11.5 VDC

Input 3

Event Input Functions: Select 2nd setpoint, and/or PID, disable output 1 and/or output 2, remote lockout

Output 1 or Output 2

Relay Rating: 240 VAC, 2 Amp

Pulsed Voltage: Source voltage 5V, Current limiting resistance 66 Ω

Linear Output — Characteristics

Type	Tolerance	Zero	Tolerance	Span	Capacity	Load
4-20 mA		3.6-4.0 mA		20-21 mA		500 Ω max
0-20 mA		0 mA		20-21 mA		500 Ω max
0-5 VDC		0 VDC		5-5.25 VDC		10 K Ω min
1-5 VDC		0.9-1.0 VDC		5-5.25 VDC		10 K Ω min
0-10 VDC		0 VDC		10-10.5 VDC		10 K Ω min

Resolution: 15 bit analog to digital converter

Isolation Breakdown Voltage: 1000 VAC

Solid State Relay (Triac) Output

Rating: 1A / 240 VAC **Inrush Current:** 20A for 1 cycle

Min. Load Current: 50 mA rms

Max. Off-state Leakage: 3 mA rms

Max. On-state Voltage: 1.5 VAC rms

Insulation Resistance: 1000 Megohms minimum at 500 VDC

Dielectric Strength: 2500 VAC for 1 minute

Rear Terminal Connections

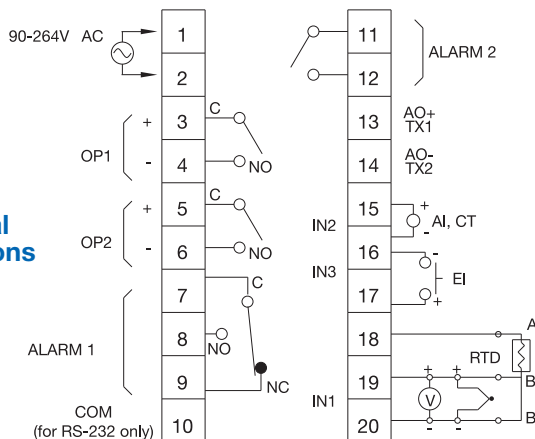

Alarm 1 / Alarm 2

Relay: 2 Amp, 240 VAC **Alarm 1:** SPDT **Alarm 2:** SPST (NO)

Alarm Functions:

Dwell timer PV1-PV2 High / Low Alarm
 Deviation Band High / Low Alarm Loop Break Alarm
 PV2 High / Low Alarm Sensor Break Alarm

Alarm Mode: Normal, Latching, Hold, Latching / Hold

Dwell Timer: 0 - 6553.5 minutes

Data Communications

Interface: RS-232 (1 unit), RS-485 (up to 247 units)

Protocol: Modbus Protocol – RTU mode

User Interface

Dual 4-digit LED Display: 0.55" (14 mm) Red Process Display

Keypad: 3 keys 0.40" (10 mm) Green Setpoint Display

Programming Port: For automatic setup, calibration and testing

Control Mode

Output 1: Reverse (heating) or direct (cooling) action

Output 2: PID cooling control, cooling P band 255% of PB

On-Off: 0.1 - 100.0°F hysteresis control (P band = 0)

P or PD: 0 - 100.0% offset adjustment

PID: Fuzzy logic modified

Proportional band: 0.1 - 932°F (500°C)

Integral: 0 - 1000 seconds **Derivative:** 0 - 360 seconds

Cycle Time: 0.1 - 100 seconds

Manual Control: Heat (MV1) and Cool (MV2)

Auto-tuning: Cold start and warm start

Failure Mode: Auto-transfer to manual mode with sensor break or A-D converter damage

Ramping Control: 0 - 900°F/min or 0 - 900°F/hr ramp rate

Power Limit: 0 - 100% for output 1 and output 2

Remote Setpoint: Programmable range for voltage or current input

Digital Filter: Time constant: settable from 0.2 to 60 seconds

Analog Retransmission

Analog Retransmission Functions: PV1, PV2, PV1-PV2, PV2-PV1, Setpoint, MV1, MV2, PV-SV deviation value

Output Signal: 4-20 / 0-20 mA, 0-1, 0-5, 1-5, 0-10 VDC

Accuracy: $\pm 0.05\%$ of span, $\pm 0.0025\%$ /°C

Environmental and Physical

Operating Temperature: 14 to 122°F (-10 to 50°C)

Humidity: 0 to 90% RH, non-condensing

Dielectric Strength: 2000 VAC, 50/60 Hz for 1 minute

Dimensions: 3-3/4 x 3-3/4 x 2-9/16" (96 x 96 x 65 mm) HxWxD
 Depth behind panel: 2" (53 mm)

Panel Cutout: 3-5/8" x 3-5/8" (92 x 92 mm) HxW

Weight: 0.56 lb. (255 grams)

Approval Standards

Safety: UL873, CSA C22.2 No. 24-93
 EN61010-1 (IEC1010-1)

Protective Class: IP 20 housing & terminals with protective covers

EMC: EN61326

Stock and Common Part Numbers

(Power Input: 90-264 VAC, no alarm 2, no data com)

Part Number	Signal Input	Out 1	Out 2	Alarm 1
TEC55001	tc-J	relay	none	relay
TEC55002	tc-J	relay	relay	none
TEC55003	tc-J	relay	relay	relay
TEC55004	tc-J	4-20 mA	none	none
TEC55005	tc-J	4-20 mA	none	relay
TEC55006	tc-J	DC pulse	none	none
TEC55007	tc-J	DC pulse	none	relay

Temperature Controllers



Models TEC-404 & TEC-405 1/4 DIN

Models TEC-404 & TEC-405 1/4 DIN Temperature Controllers



With Dial or Pushwheel Setpoint and Display!

Design Features

- * 1/4 DIN size – 96 mm × 96 mm
- * Model TEC-404 Temperature Control with dial/potentiometer setpoint
- * Model TEC-405 Temperature Control with pushwheel setpoint
- * Laser trimmed ASIC components
- * On-off or time proportional selection
- * Short panel depth – only 2.0" (51 mm) required
- * Digital display, 0.56" (14 mm) red LED
- * Wide selection of output options
- * Universal power input, 90-264 VAC or 20-32 VAC/VDC
- * Sensor break protection
- * Good performance at a very low price

Potentiometer Setpoint

Hardware Code: TEC-404-

1	2	3	4	5	6	7	8
<input type="text"/>	<input type="text"/>	<input type="text"/>	<input type="text"/>	<input type="text"/>	<input type="text"/>	<input type="text"/>	<input type="text"/>

A Part Number based on the hardware code and any software pre-programming will be issued at time of order.

Standard lead time is stock to 2 weeks.

Pushwheel Setpoint

Hardware Code: TEC-405-

1	2	3	4	5	6	7	8
<input type="text"/>	<input type="text"/>	<input type="text"/>	<input type="text"/>	<input type="text"/>	<input type="text"/>	<input type="text"/>	<input type="text"/>

A Part Number based on the hardware code and any software pre-programming will be issued at time of order.

Standard lead time is stock to 2 weeks.

Agency Approvals



Power Input BOX 1

- 4 = 90-264 VAC 50/60 Hz
- 5 = 20-32 VAC 50/60 Hz, 20 - 32 VDC

Signal Input BOX 2

- 1 = Thermocouple: Type J
- 2 = Thermocouple: Type K
- 3 = RTD: 100 ohm PT, DIN 0.00385
- 4 = RTD: 100 ohm PT, JIS 0.00392
- 9 = Other

Standard Range Code

- (TEC-404 only) BOX 3
- 4 = 0 to 300°C C = 50 to 550°F
 - 6 = 0 to 600°C E = 50 to 850°F

Below available for large volume orders. Consult Tempco for more information.

- 2 = 0 to 100°C A = 50 to 200°F
- 3 = 0 to 200°C B = 50 to 400°F
- 5 = 0 to 400°C D = 50 to 750°F
- 7 = 0 to 800°C F = 50 to 1100°F
- 8 = 0 to 1200°C G = 50 to 1400°F
- 9 = Other H = 0 to 2200°F

Range code (TEC-405 only) BOX 3

- X = 0 to 499°F C = 0 to 299°C
- V = 0 to 999°F E = 0 to 499°C
- W = 0 to 1999°F H = 0 to 999°C

Other ranges are available for large volume orders. Consult Tempco for more information.

Control Mode BOX 4

- 1 = On - Off (used for valves & solenoids)
- 2 = Proportional (common for electric heaters)

Output 1 BOX 5

- 1 = Relay: 5A / 240 VAC
- 2 = Pulse DC for SSR drive: 20 VDC (20 mA max)
- 3 = 4-20 mA, linear (max load 500 ohms)
- 4 = 0-20 mA, linear (max load 500 ohms)
- 5 = 0-10 VDC, linear (min. impedance 500K ohms)
- 9 = Other

Output 2 BOX 6

- 0 = Not Available

Alarm BOX 7

- 0 = None
- 1 = Relay: 3A / 240 VAC Deviation alarm

Communication BOX 8

- 0 = Not Available

Power Input

Standard: 90 - 264 VAC, 50/60 Hz, 5VA
Optional: 20 - 32 VAC 50/60 Hz, 20 - 32 VDC, 5VA

Signal Input

Accuracy: $\pm 1.0\%$ of full scale at 77°F/25°C
Thermocouple: Type J or K
RTD: 3-wire Pt100 DIN or JIS
Sampling Rate: 3 samples per second
Cold Junction Compensation: $\pm 0.1^\circ\text{C} / 1^\circ\text{C}$
Common Mode Rejection Ratio (CMRR): 120 dB
Normal Mode Rejection Ratio (NMRR): 60 dB
Sensor Break Protection: Upscale

Output 1

Relay Rating: 5 Amp, 240 VAC
SSR drive: Pulsed DC, 20 V at 20 mA maximum
Current Loop: 4 - 20 mA, 0 - 20 mA, maximum load: 500Ω
Voltage: 0 - 10 VDC, minimum load 500 KΩ

Control

Proportional Band: 2.2% of span
ON-OFF Hysteresis: 1% of span
Cycle time: 20 seconds for relay output, 1 second for pulsed voltage output, 0.02 second for linear current or voltage output
Control Action: Reverse Action

Approval Standards

Safety Standard: UL3121-1
 EN61326
Protective Class: Front panel: IP 30
 Housing and Terminals: IP 20

Adjustment

Setpoint: Single turn wirewound potentiometer (TEC-404)
Setpoint Resolution: 0.2% of span
Accuracy of Setpoint: $\pm 2\%$ of span
Repeatability of Setpoint: $\pm 0.1\%$ of span
Setpoint: 3-digit or 4-digit pushwheel switch (TEC-405)
Manual Reset: Adjustable up to 2.6% of span
Setpoint Resolution: ± 1 Least Significant Digit
Accuracy of Setpoint: $\pm 1\%$ of span
Repeatability of Setpoint: ± 1 Least Significant Digit

Display

Single 4-digit LED Display: 0.56" (14 mm) Red

Environmental and Physical

Operating Temperature: 32 to 122°F (0 to 50°C)
Humidity: 0 to 90% RH, non-condensing
Dielectric Strength: 2000 VAC, 50/60 Hz for 1 minute
Vibration: 10 - 55 Hz, amplitude 1 mm
Shock: 200 m/s² (20g)
Dimensions: 3-3/4 × 3-3/4 × 2-9/16" (96 × 96 × 65 mm) H×W×D
 Depth behind panel: 2" (53 mm)
Panel Cutout: 3-5/8" × 3-5/8" (92 × 92 mm) H×W
Weight: 0.55 lb. (250 grams)

Rear Terminal Connections

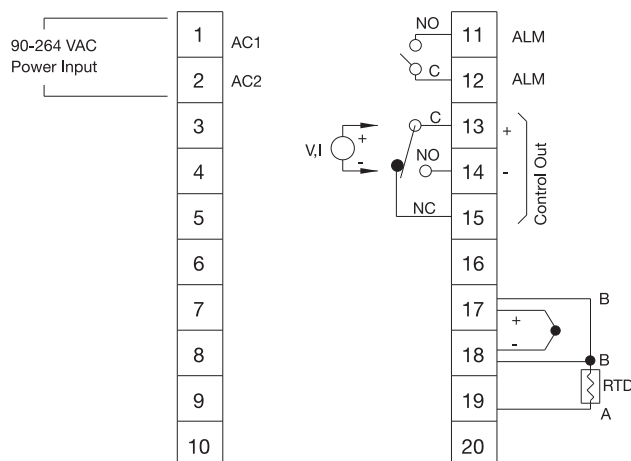

Potentiometer Setpoint TEC-404 Stock and Common Part Numbers (Power Input: 90-264 VAC, Proportional Mode)

Part Number	Signal Input	Range	Output	Alarm
TEC57401	J tc	50-850°F	relay	none
TEC57402	J tc	50-550°F	relay	none
TEC57403	K tc	50-850°F	relay	none
TEC57404	K tc	50-550°F	relay	relay
TEC57405	RTD	50-550°F	relay	none
TEC57406	J tc	0-300°C	relay	none
TEC57407	J tc	0-600°C	relay	none
TEC57408	K tc	0-300°C	relay	none
TEC57409	K tc	0-600°C	relay	none

Pushwheel Setpoint TEC-405 Stock and Common Part Numbers (Power Input: 90-264 VAC, Proportional Mode)

Part Number	Signal Input	Range	Output	Alarm
TEC57511	J tc	0-999°F	relay	none
TEC57512	J tc	0-499°F	relay	none
TEC57513	K tc	0-1999°F	relay	none
TEC57514	K tc	0-999°F	relay	none
TEC57515	J tc	0-499°C	relay	none
TEC57516	J tc	0-299°C	relay	none
TEC57517	K tc	0-999°C	relay	none
TEC57518	K tc	0-499°C	relay	none
TEC57519	RTD	0-999°F	relay	none
TEC57520	RTD	0-499°C	relay	none

Temperature Controllers



Models TEC-402 & TEC-401 1/4 DIN

Models TEC-402 & TEC-401 1/4 DIN Temperature Controllers



With Process Temperature Deviation Meter!



Low Cost Non-Indicating Control!

Design Features

- * 1/4 DIN size – 96 mm × 96 mm
- * Model TEC-402 temperature control with deviation meter
- * Model TEC-401 non-indicating temperature control
- * Laser trimmed ASIC components
- * Short panel depth – only 2.0" (51 mm) required
- * On-off or time proportional selection
- * Wide selection of output options
- * Potentiometer setpoint
- * Sensor break protection
- * Good performance at a very low price

Agency Approval:

With Deviation Meter

Hardware Code: TEC-402-

A Part Number based on the hardware code and any software pre-programming will be issued at time of order.

Standard lead time is stock to 2 weeks.

Non-Indicating

Hardware Code: TEC-401-

A Part Number based on the hardware code and any software pre-programming will be issued at time of order.

Standard lead time is stock to 2 weeks.

Power Input BOX 1

- 3 = 100-130 VAC, 50/60 Hz or 200-240 VAC, 50/60 Hz

Control Mode BOX 4

- 1 = On - Off (used for valves & solenoids)
- 2 = Proportional (common for electric heaters)

Communication BOX 8

- 0 = Not Available

Signal Input BOX 2

- 1 = Thermocouple: Type J
- 2 = Thermocouple: Type K
- 3 = RTD: 100 ohm PT, DIN 0.00385
- 4 = RTD: 100 ohm PT, JIS 0.00392
- 9 = Other

Output 1 BOX 5

- 1 = Relay: 5A / 240 VAC
- 2 = Pulse DC for SSR drive: 20 VDC (20 mA max)
- 3 = 4-20 mA, linear (max load 500 ohms)
- 4 = 0-20 mA, linear (max load 500 ohms)
- 5 = 0-10 VDC, linear (min. impedance 500K ohms)
- 9 = Other

Standard Range Code BOX 3

- 4 = 0 to 300°C C = 50 to 550°F
- 6 = 0 to 600°C E = 50 to 850°F

Below available for large volume orders. Consult Tempco for more information.

- 2 = 0 to 100°C A = 50 to 200°F
- 3 = 0 to 200°C B = 50 to 400°F
- 5 = 0 to 400°C D = 50 to 750°F
- 7 = 0 to 800°C F = 50 to 1100°F
- 8 = 0 to 1200°C G = 50 to 1400°F
- 9 = Other H = 0 to 2200°F

Output 2 BOX 6

- 0 = Not Available

Alarm (TEC-402) only BOX 7

- 0 = None
- 1 = Relay: 3A / 240 VAC deviation alarm

Power Input

100 - 130 VAC, 50/60 Hz, 5VA
200 - 240 VAC, 50/60 Hz, 5VA

Signal Input

Thermocouple: Type J or K
RTD: 3-wire Pt100 DIN or JIS
Sampling Rate: 3 samples per second
Accuracy: $\pm 2\%$ of span
Cold Junction Compensation: $\pm 0.1^\circ\text{C} / 1^\circ\text{C}$
Common Mode Rejection Ratio (CMRR): 120 dB
Normal Mode Rejection Ratio (NMRR): 60 dB
Sensor Break Protection: Upscale

Output 1

Relay Rating: 5 Amp, 240 VAC
SSR drive: Pulsed DC, 20 V at 20 mA maximum
Current Loop: 4 - 20 mA, 0 - 20 mA, maximum load: 500 Ω
Voltage: 0 - 10 VDC, minimum load 500 K Ω

Control

Proportional Band: 2.2% of span
ON-OFF Hysteresis: 1% of span
Cycle time: 20 seconds for relay output, 1 second for pulsed voltage output, 0.02 second for linear current or voltage output
Control Action: Reverse Action

Approval Standards

Safety Standard: EN61326
Protective Class: Front panel: IP 30
Housing and Terminals: IP 20

Adjustment

Setpoint: Single turn wirewound potentiometer
Setpoint Resolution: 0.2% of span
Accuracy of Setpoint: $\pm 2\%$ of span
Repeatability of Setpoint: $\pm 0.1\%$ of span

Display

Deviation meter: $\pm 10\%$ of scale (TEC-402)
Non-Indicating (TEC-401)

Environmental and Physical

Operating Temperature: 32 to 122 $^\circ\text{F}$ (0 to 50 $^\circ\text{C}$)
Humidity: 0 to 90% RH, non-condensing
Dielectric Strength: 2000 VAC, 50/60 Hz for 1 minute
Vibration: 10 - 55 Hz, amplitude 1 mm
Shock: 200 m/s² (20g)
Dimensions: 3-3/4 \times 3-3/4 \times 2-9/16" (96 \times 96 \times 65 mm) H \times W \times D
Depth behind panel: 2" (53 mm)
Panel Cutout: 3-5/8" \times 3-5/8" (92 \times 92 mm) H \times W
Weight: 0.79 lb. (360 grams)

Rear Terminal Connections

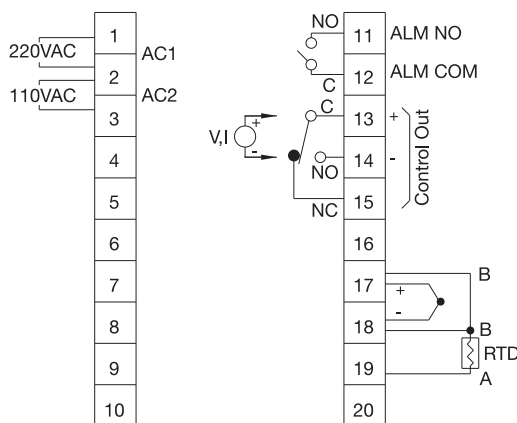

(For TEC-401 Pins 11 and 12 are not used)

With Deviation Meter TEC-402 Stock and Common Part Numbers (Proportional mode)

Part Number	Signal Input	Range	Output	Alarm
TEC57201	J tc	50-850 $^\circ\text{F}$	relay	none
TEC57202	J tc	50-550 $^\circ\text{F}$	relay	none
TEC57203	K tc	50-850 $^\circ\text{F}$	relay	none
TEC57204	K tc	50-550 $^\circ\text{F}$	relay	relay
TEC57205	RTD	50-550 $^\circ\text{F}$	relay	none
TEC57206	J tc	0-300 $^\circ\text{C}$	relay	none
TEC57207	J tc	0-600 $^\circ\text{C}$	relay	none
TEC57208	K tc	0-300 $^\circ\text{C}$	relay	none
TEC57209	K tc	0-600 $^\circ\text{C}$	relay	none

Non-Indicating TEC-401 Stock and Common Part Numbers (Proportional mode)

Part Number	Signal Input	Range	Output
TEC57101	J tc	50-850 $^\circ\text{F}$	relay
TEC57102	J tc	50-550 $^\circ\text{F}$	relay
TEC57103	K tc	50-850 $^\circ\text{F}$	relay
TEC57104	K tc	50-550 $^\circ\text{F}$	relay
TEC57105	RTD	50-550 $^\circ\text{F}$	relay
TEC57106	J tc	0-300 $^\circ\text{C}$	relay
TEC57107	J tc	0-600 $^\circ\text{C}$	relay
TEC57108	K tc	0-300 $^\circ\text{C}$	relay
TEC57109	K tc	0-600 $^\circ\text{C}$	relay

Model TBC-41 Board PID Temperature Control

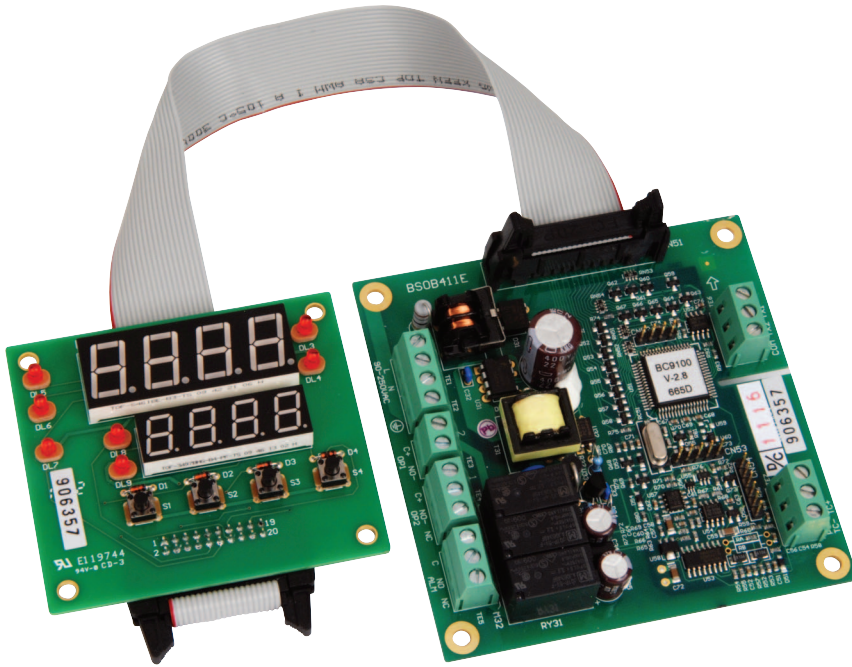

*Board Control Fuzzy Logic PID,
Configurable for 4 Programmable Outputs!*

Design Features

- * Easy to use high performance at a low price
- * Fuzzy Logic PID Autotune heat and cool control
- * Fast A-D sampling rate (5 samples/second)
- * Universal input, field configurable (Type J T/C default, PT100, mA, V) with high accuracy 18-bit D-A
- * Analog output (linear current or voltage) uses high accuracy 15-bit D-A Converter
- * Optional RS-232 or RS-485 communications interface
- * Universal input power— 90-250 VAC 50/60HZ or 11-26 VAC/VDC
- * Programming port provided on board
- * Supports manual control & auto-tune functions
- * Wide variety of alarm mode selections
- * Lockout Protection
- * Bumpless transfer
- * Soft-start ramp and dwell timer
- * Bright 0.55" (14 mm) red LED process display
- * Available from Stock
- * Agency Approvals:



Ordering Code:

TBC-41 - 1 2 3 4 5 6 7

Power Input BOX 1

- 4 = 90-250 VAC, 50-60 Hz
- 5 = 11-26 VAC / VDC

Signal Input — BOX 2

- 1 = Thermocouple: J (default), K, T, E, B, R, S, N, L, RTD PT100 DIN
- 2 = 0-60mV
- 3 = 0-1 VDC
- 4 = 0-5 VDC
- 5 = 1-5 VDC
- 6 = 4-20 mA
- 7 = 0-20 mA
- 8 = 0-10 VDC
- 9 = Other

Output 1 BOX 3

- 1 = Relay: 2A / 240 VAC
- 2 = Pulse DC for SSR drive: 5 VDC (30 mA max)
- 3 = Isolated 4-20 mA (default), 0-20 mA
- 4 = Isolated VDC, 1-5 (default), 0-5
- 5 = Isolated VDC, 0-10
- 6 = Triac-SSR output 1A / 240 VAC
- C = Pulse DC for SSR drive: 14 VDC (40 mA max)

Output 2 BOX 4

- 0 = None
- 1 = Relay: 2A / 240 VAC Form A
- 2 = Pulse DC for SSR drive: 5 VDC (30 mA max)
- 3 = Isolated 4-20 mA (default), 0-20 mA
- 4 = Isolated VDC, 1-5 (default), 0-5
- 5 = Isolated VDC, 0-10
- 6 = Triac-SSR output 1A / 240 VAC
- 7 = Isolated 24V @ 25 mA DC, Output Power Supply
- 8 = Isolated 12V @ 40 mA DC, Output Power Supply
- 9 = Isolated 5V @ 80 mA DC, Output Power Supply
- C = Pulse DC for SSR drive: 14 VDC (40 mA max)

Alarm BOX 5

- 0 = None
- 1 = Relay: 2A / 240 VAC, Form C

Communication BOX 6

- 0 = None
- 1 = RS-485 Interface
- 2 = RS-232 Interface
- 3 = Retransmission 4-20 mA (default), 0-20 mA
- 4 = Retransmission 1-5 VDC (default), 0-5 VDC
- 5 = Retransmission 0-10 VDC

Display Board and Cable BOX 7

- 0 = None
 - 3 = With Display Board and 12" (300 mm) Cable (default)
- Consult Tempco for other cable lengths.

⚠ WARNING: Cancer and Reproductive Harm - www.P65Warnings.ca.gov.

View Product Inventory @ www.tempco.com

The new Tempco TBC-41 PID board temperature controller has been designed to be built into equipment by OEMs. This highly accurate electronic controller can easily be installed behind an overlay or control panel to allow for a very smooth and built-in look. Its many features can easily control electric or gas heating & cooling devices.

The fuzzy logic plus PID microprocessor-based controller series incorporates two bright, easy to read 4-digit LED displays, indicating process value and setpoint value. The fuzzy logic technology enables a process to reach a predetermined setpoint in the shortest time with the minimum of overshoot during power-up or external load disturbance.

The unit is powered by 11-26 or 90-250 VDC /VAC supply.

The second output can be used as cooling control or an alarm. Both outputs can select relay, triac, 5V logic output, linear current or linear voltage to drive an external device. There are six types of alarms, plus a dwell timer, that can be configured for the third output. The units are fully programmable for PT100 and thermocouple types J, K, T, E, B, R, S, N and L. The input signal is digitized by using an 18-bit A to D converter. Its fast sampling rate allows the unit to control fast processes.

Optional digital communications via RS-485 or RS-232 are available. These options allow the units to be integrated with supervisory control systems and software.

A programming port is available for automatic configuration, calibration and testing without the need to access the keys on the front panel.

By using proprietary fuzzy logic modified PID technology, this control will minimize the overshoot and undershoot in the shortest time.

High Accuracy

The TBC series controls are manufactured with custom designed ASIC (Application Specific Integrated Circuit) technology which contains an 18-bit A to D converter for high resolution measurement (true 0.1°F resolution for thermocouple and PT100) and a 15-bit D to A converter for linear current or voltage control output. The ASIC technology provides improved operating performance, low cost, enhanced reliability and higher density.

Fast Sampling Rate

The sampling rate of the input A to D converter is 5 samples/second. The fast sampling rate allows this series to control fast processes.

Fuzzy Control

The function of fuzzy logic control is to continually vary the PID parameters in a slight manner to allow for a more precise control of your process, over time. Also, this allows your process to reach the setpoint in the shortest amount of time with minimal overshoot during initial heat-up or setpoint and load changes.

Digital Communication

Optional RS-232 or RS-485 interface modules allow for Modbus RTU digital communications. The RS-485 interface allows for a maximum of 247 controllers to be connected to a host computer.

Programming Port

A programming port is used to connect the unit to a PC for quick configuration.

Auto-tune

The auto-tune function allows the user to simplify initial setup for a new system. A clever algorithm is provided to obtain an optimal set of control parameters for the process, it can be applied either as the process is warming up (cold start) or if the process has been in steady state (warm start).

Lockout Protection

According to the actual security requirement, one of four lock-out levels can be selected to prevent the unit from being changed by unauthorized persons.

Bumpless Transfer

Bumpless transfer allows the controller to continue to control by using its previous value if the sensor breaks. Hence, the process can be well controlled temporarily.

Soft-start Ramp

The ramping function can be performed during power-up as well as any time the setpoint is changed. The ramp function works during heat-up and cool-down.

Digital Filter

A first order low pass filter with a programmable time constant is used to improve the stability of process value. This is particularly useful in certain applications where the process value is too unstable to read.

SEL Function

The units have the flexibility for the user to move as many as 8 parameters, which are the most significant, from the set-up menu and place them in the front of the display sequence in the user menu.

Stock and Common Part Numbers

Part Number	Signal Input	Output 1	Output 2	Alarm
TBC10001	tc	relay	none	none
TBC10002	tc	relay	relay	none
TBC10003	tc	relay	relay	relay
TBC10010	tc	5VDC Pulse	none	none



TBC-41 Board PID Control

Continued from previous page...

Power

90-250 VAC, 47-63 Hz, 12VA, 5W max.
11-26 VAC / VDC, SELV, Limited Energy, 12VA, 5W max.

Input

Resolution: 18 bits
Sampling Rate: 5 samples/second
Max. Rating: -2 VDC min, 12 VDC max.
(1 minute for mA input)
Temperature Effect: $\pm 1.5\text{uV}/^\circ\text{C}$ for all inputs except mA
 $\pm 3.0\text{uV}/^\circ\text{C}$ for mA input
Sensor Lead Resistance Effect:
T/C: 0.2uV/ohm
3-wire RTD: 2.6°C/ohm of resistance difference of two leads
2-wire RTD: 2.6°C/ohm of resistance sum of two leads

Burn-out Current: 200 mA

Common Mode Rejection Ratio (CMRR): 120dB

Normal Mode Rejection Ratio (NMRR): 55dB

Sensor Break Detection:

Sensor open for TC, RTD and mV inputs
Sensor short for RTD input
Below 1 mA for 4-20 mA input
Below 0.25V for 1-5 V input
Unavailable for other inputs

Sensor Break Responding Time:

Within 4 seconds for TC, RTD and mV inputs
0.1 second for 4-20 mA and 1-5 V inputs

Output 1 / Output 2

Relay Rating: 2A/240 VAC, life cycles 200,000 for resistive load

Pulsed Voltage: Source Voltage 5V
current limiting resistance 66Ω

Linear Output

Resolution: 15 bits
Output Regulation: 0.02% for full load change
Output Settling Time: 0.1 sec. (stable to 99.9%)
Isolation Breakdown Voltage: 1000 VAC
Temperature Effect: $\pm 0.01\%$ of SPAN / °C

Triac (SSR) Output

Rating: 1A / 240 VAC
Inrush Current: 20A for 1 cycle
Min. Load Current: 50 mA rms
Max. Off-state Leakage: 3 mA rms
Max. On-state Voltage: 1.5 V rms
Insulation Resistance: 1000 Mohms min. at 500 VDC
Dielectric Strength: 2500 VAC for 1 minute

Alarm

Alarm Relay: Form C Rating
2A/240VAC, life cycles 200,000 for resistive load
Alarm Functions: Dwell timer, Deviation High / Low Alarm
Deviation Band High / Low Alarm
PV High / Low Alarm
Alarm Mode: Normal, Latching, Hold, Latching / Hold
Dwell Timer: 0.1-4553.6 minutes

Data Communication

Interface: RS-232 (1 unit), RS-485 (up to 247 units)
Protocol: Modbus Protocol RTU mode
Address: 1-247
Baud Rate: 2.4~38.4 Kbits/sec
Data Bits: 7 or 8 bits
Parity Bit: None, Even or Odd
Stop Bit: 1 or 2 bits
Communication Buffer: 160 bytes

Analog Retransmission

Output Signal: 4-20 mA, 0-20 mA, 0-5V
1 - 5V, 0 - 10V
Resolution: 15 bits
Accuracy: $\pm 0.05\%$ of span $\pm 0.0025\%$ / °C
Load Resistance:
0 - 500 ohms (for current output)
10 K ohms minimum (for voltage output)
Output Regulation: 0.01% for full load change
Output Settling Time: 0.1 sec. (stable to 99.9%)
Isolation Breakdown Voltage: 1000 VAC min.
Integral Linearity Error: $\pm 0.005\%$ of span
Temperature Effect: $\pm 0.0025\%$ of span / °C
Saturation Low: 0 mA (or 0V)
Saturation High: 22.2 mA (or 5.55V, 11.1V min.)
Linear Output Range: 0-22.2mA (0-20mA or 4-20mA)
0-5.55V (0-5V, 1-5V)
0-11.1 V (0-10V)

User Interface

Dual 4-digit LED Displays
Keypad: 4 keys
Programming Port: For automatic setup, calibration and testing
Communication Port: Connection to PC for supervisory control

Control Mode

Output 1: Reverse (heating) or direct (cooling) action
Output 2: PID cooling control, cooling P band 50~300%
of PB, dead band -36.0~36.0% of PB
ON-OFF: 0.1-90.0 (°F) hysteresis control (P band = 0)
P or PD: 0-100.0% offset adjustment
PID: Fuzzy Logic modified
Proportional band 0.1~900.0°F
Integral time 0-3600 seconds
Derivative time 0-360.0 seconds
Cycle Time: 0.1-90.0 seconds
Manual Control: Heat (MV1) and Cool (MV2)
Auto-tuning: Cold start and warm start
Failure Mode: Auto-transfer to manual mode while
sensor break or A-D converter damage
Ramping Control: 0-900.0°F/minute or
0-900.0°F/hour ramp rate

Digital Filter

Function: First order
Time Constant: 0, 0.2, 0.5, 1, 2, 5, 10, 20, 30, 60
seconds programmable

Environmental & Physical

Operating Temperature: -10°C to 50°C

Storage Temperature: -40°C to 60°C

Humidity: 0 to 90% RH (non-condensing)

Altitude: 2000m maximum

Pollution: Degree 2

Insulation Resistance: 20 Mohms min. (at 500 VDC)

Dielectric Strength: 2000 VAC, 50/60 Hz for 1 minute

Vibration Resistance: 10-55 Hz, 10 m/s² for 2 hours

Shock Resistance: 200 m/s² (20 g)

Approval Standard

EMC: EN61326

Control Board Overlay Dimensions (mm)

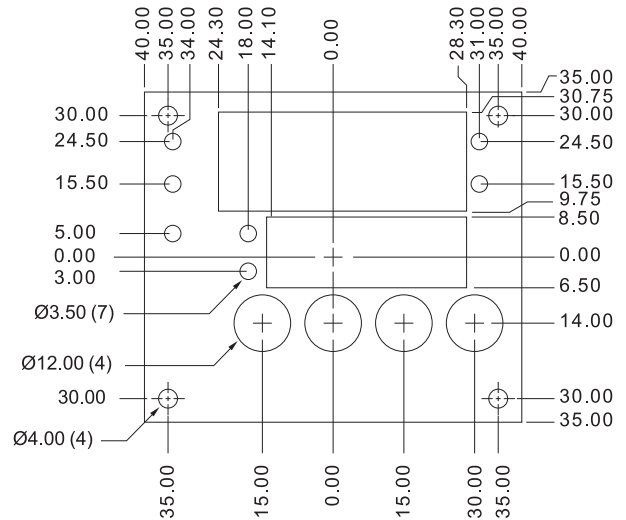

Control PC Board Dimensions (mm)

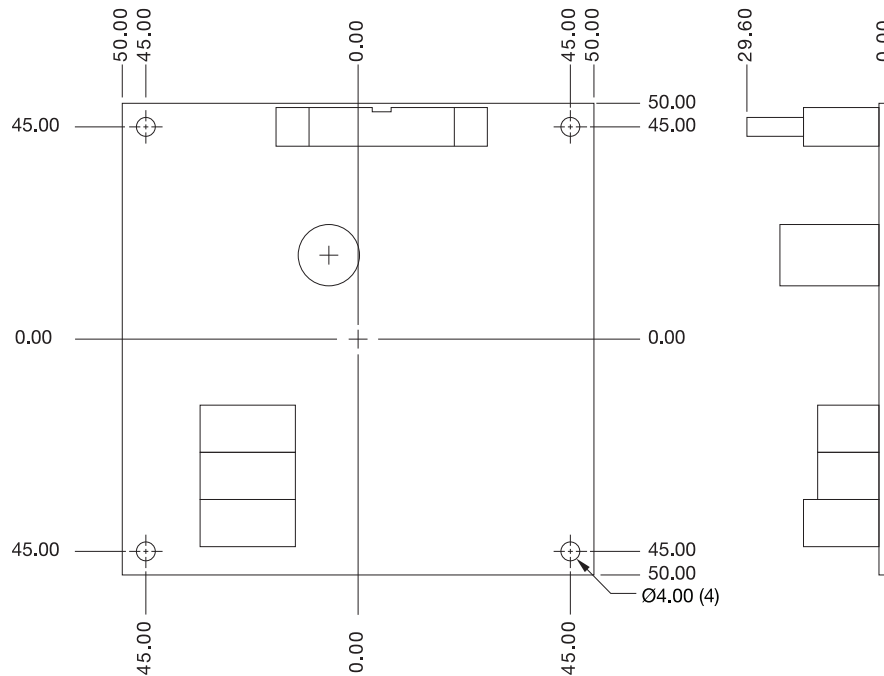

TEC Family of Controllers — Common Design Features for the Models Listed

1/32 DIN: TEC-220, TEC-2400, TEC-2500

1/16 DIN: TEC-920, TEC-9100, TEC-9090, TEC-9300, TEC-9400

1/8 DIN: TEC-8100, TEC-8300, TEC-8400, TEC-8450

3/16 DIN: TEC-7100, TEC-7400

1/4 DIN: TEC-4100, TEC-4300, TEC-4400

DIN Rail Mount: TEC-6400

High Accuracy

The TEC Series is manufactured with custom-designed ASIC (Application Specific Integrated Circuit) technology, which contains an 18-bit Analog to Digital converter for high resolution measurement (true 0.1°F resolution for thermocouple and PT100 RTDs) and a 15-bit D to A converter for linear current or voltage control outputs. The ASIC technology provides improved operating performance, low cost, enhanced reliability and higher component density.

Auto-Tune

The auto-tune function allows the user to simplify initial setup for a new system by automatically determining the optimum set of PID settings for the thermodynamic system. A unique algorithm is programmed into the microprocessor to obtain an optimal set of control parameters for the process, and it can be applied either as the process is warming up (cold start) or if the process has been in a steady state (warm start).

Fuzzy Logic Control

The function of Fuzzy Logic Control is to adjust the PID parameters from time to time in order to make the modulated output value more flexible and adaptive to various processes. The result is to enable a process to reach a predetermined setpoint in the shortest time, with the minimum of overshoot and undershoot during power-up or external load disturbances.

Digital Filter

A first-order low-pass digital filter with a programmable time constant is a standard function of the software developed for the TEC controllers. It is used to improve the stability of the process value, especially in electrically noisy environments.

Lockout Protection

According to the actual security requirements, one of four lockout levels can be selected to prevent the unit from being changed erroneously.

None: No parameter is locked.

Set: User data is accessible, but setup data is locked.

User: All user and setup parameters are locked, except setpoint.

All: All user and setup parameters are locked, including setpoint.

Bumpless Transfer

Bumpless transfer allows the controller to continue to control the process by using the last known good output percentage value if the temperature sensor should fail. Hence, the process transfers from feedback closed loop control to open loop control and the process can be kept running until the sensor can be replaced.

Soft Start Ramp

The ramping function is performed during power up as well as any time the setpoint is changed. It can be ramping up or ramping down. The process value will reach the setpoint with a predetermined constant rate of rise or fall.

Digital Communications

The units can be equipped with a RS-485 or RS-232 interface card to provide digital communications. By using only twisted pair wires, up to 247 controllers can be connected together via the RS-485 interface to a host computer.

Table of Input Range and Sensor Accuracy

Type	Range	Accuracy @ 25°C	Input Impedance
J	-184 to 1832°F -120 to 1000°C	±3.6°F ±2.0°C	2.2MΩ
K	-328 to 2498°F -200 to 1370°C	±3.6°F ±2.0°C	2.2MΩ
T	-418 to 752°F -250 to 400°C	±3.6°F ±2.0°C	2.2MΩ
E	-148 to 1652°F -100 to 900°C	±3.6°F ±2.0°C	2.2MΩ
B	32 to 3272°F 0 to 1800°C	±3.6°F ±2.0°C	2.2MΩ

Type	Range	Accuracy @ 25°C	Input Impedance
R	32 to 3214°F 0 to 1767°C	±3.6°F ±2.0°C	2.2MΩ
S	32 to 3214°F 0 to 1767°C	±3.6°F ±2.0°C	2.2MΩ
N	-418 to 2372°F -250 to 1300°C	±3.6°F ±2.0°C	2.2MΩ
L	-328 to 1652°F -200 to 900°C	±3.6°F ±2.0°C	2.2MΩ
PT100 (DIN)	-346 to 1292°F -210 to 700°C	±0.7°F ±0.4°C	1.3KΩ
PT100 (JIS)	-328 to 1112°F -200 to 600°C	±0.7°F ±0.4°C	1.3KΩ
mV	-8 to 70mV	±0.05%	2.2MΩ
mA	-3 to 27mA	±0.05%	70.5Ω
VDC	-1.3 to 11.5Vdc	±0.05%	650KΩ

DIN Rail/Surface Mount Adapter for 1/16 DIN Controls

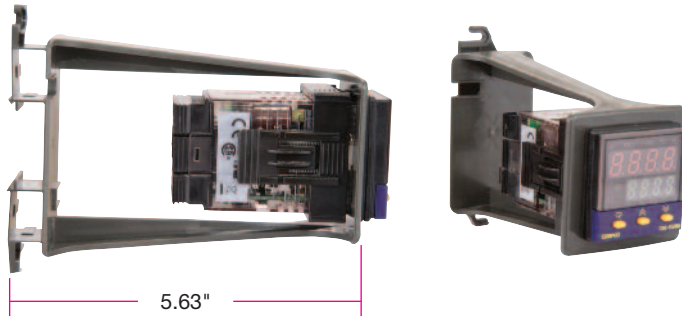

Cutout for Control – 45 mm/1.772" square
Maximum DIN Control Depth – 120 mm/4.72"
Material – Fire Retardant Polycarbonate GE Lexan® 940
Part Number: TEC99920

Polycarbonate Touchsafe Terminal Covers



Part Number: TEC99921 (sold per piece)
1/8 and 1/4 DIN – Fits Controller Models:
 TEC-8100, TEC-8300, TEC-805, TEC-4100,
 TEC-4300, TEC-401, TEC-402, TEC-404,
 TEC-405, TEC-4500

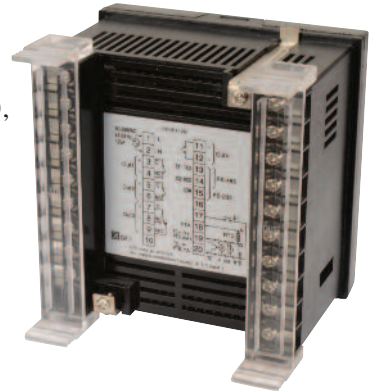

Part Number: TEC99922 (sold per piece)
1/16 DIN – Fits Controller Models:
 TEC-9090, TEC-910, TEC-920,
 TEC-901, TEC-902, TEC-905

Adapter Plates



18 gauge Stainless Steel Adapter Plates
 with (4) #8 self-tapping sheet metal
 screws for mounting

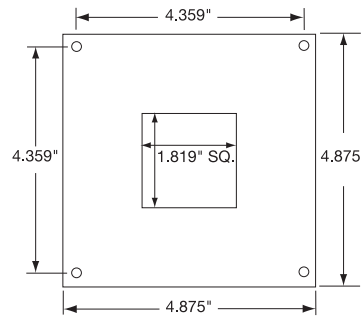

TEC99901
 Adapts a 1/4 DIN cut-out
 to a 1/16 DIN cut-out.

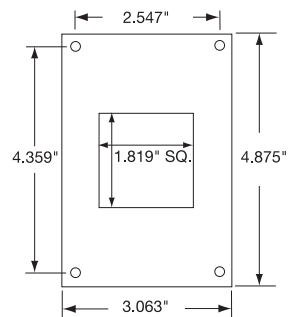

TEC99902
 Adapts a 1/8 DIN cut-out
 to a 1/16 DIN cut-out.

Model TEC 99999 Current Transformer/Transducer for use with Heater Break Alarm

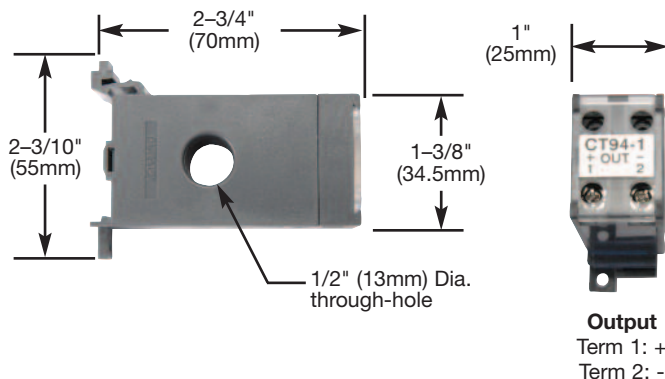

Design Features

- * High Accuracy: $\pm 2\%$ of Reading $\pm 0.2A$
- * Wide Measuring Range: 0 – 50 Amps AC
- * DC Voltage Output: 0 – 5 VDC
- * 35 mm DIN Rail Mount or Surface Mount
- * 7/16" (12.5mm) diameter maximum cable size



Note:
 1 required for 1 Phase – 50A Max.
 3 required for 3 Phase – 100A Nominal Max.

TEC Accessories

Data Communication Accessories

TEC99001 — Smart Network Adapter for third party SCADA software which converts 255 channels of RS-485 or RS-422 to RS-232 Network.

TEC99003 — Smart Network Adapter for connecting the TEC controller's programming port to the RS-232 PC serial port. Allows downloading and reading of configuration information directly from a personal computer. Can be used with TEC-220, TEC-410, TEC-910, TEC-920, TEC-2500, TEC-4100, TEC-4300, TEC-4500, TEC-7100, TEC-8100, TEC-8300, TEC-9100, TEC-9300, TEC-9500 and TBC-41.

TEC99030 — "Tempco Config Set" PC software for use with TEC99003 Smart Network Adapter

Minimum System Requirements:
Microsoft Windows XP, 2000, NT, 98, 95
Pentium 200 MHz or faster
32 MB RAM (64 MB recommended)
Hard disk space: 2 MB

Note: Can be downloaded at no charge from www.tempco.com

Programming Port Cables

TEC99011 — Used for models TEC-220, TEC-4100, TEC-7100, TEC-8100 and TEC-9100.

TEC99012 — Used for model TEC-920 only.

TEC99013 — Used for models TEC-2500, TEC-4300, TEC-8300 and TEC-9300.

TEC99014 — RS-232 interface cable for models TEC-220, TEC-410, TEC-2500, TEC-4100, TEC-4300, TEC-4500, TEC-8100, TEC-8300, TEC-9100, TEC-9300, TEC-9500 and TBC-41.

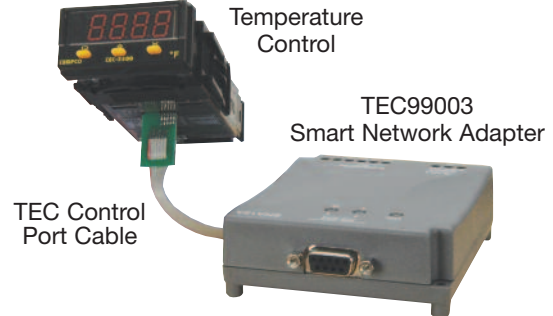

Part Number TEC99927 — Converter Connects RS232/RS422/RS485 Devices To PC Via USB Port

Part Number TEC99928 — Converter Connects RS422/RS485 Devices To PC Via USB Port



Part Number TEC99927

Design Features

- * Ideal for interfacing with TEC controllers, PPR chart recorders, PLCs, and general protocol conversion to a USB port
- * Full-Speed USB operation at up to 12 Mbps
- * Additional I/O or IRQ not required
- * Serial transmission speed up to 921.6 Kbps
- * 64-byte FIFO and built-in hardware and software flow control
- * Built-in 15 KV ESD protection
- * Support for RS-232, RS-422, 2-wire RS-485, and 4-wire RS-485
- * Terminal block adapter



Part Number TEC99928

Specifications TEC99927

USB

Version: 900/1800 MHz, dual band
Connector: USB type B
Speed: 12 Mbps

Serial Interface

Number of Ports: 1
RS-232: Tx/D, Rx/D, RTS, CTS, DTR, DSR, DCD, GND
RS-422: TxD+(B), TxD-(A), RxD+(B), RxD-(A), GND
RS-485: 4-wire: TxD+(B), TxD-(A), RxD+(B), RxD-(A), GND
2-wire: Data+(B), Data-(A), GND
Connector: Male DB9
FIFO: 64 bytes
Serial Line Protection: 15 KV ESD for all signals

Serial Communications Parameters

Parity: None, Even, Odd, Space, Mark
Data Bits: 5, 6, 7, 8
Stop Bits: 1, 1.5, 2
Flow Control: RTS/CTS, XON/XOFF
Speed: 50 bps to 921.6 Kbps

Power Requirements

Power Consumption: 30 mA@5 VDC

Mechanical

Dimensions: 37.5 × 20.5 × 60 mm (L × W × H)

Specifications TEC99928

Chipset: Silicon Laboratories CP2102
Compliant: USB 1.0, 1.1, 2.0
Connector: USB type A
Baud Rates: Full Speed 12 Mbps

RS232/485 To Ethernet Converter

Tempco Ethernet converter / Gateway is capable of linking any serial (RS-232 or RS485) devices to your computer network via Ethernet for remote access, control, and/or monitoring purposes. Works with Tempco electronics (controllers, data loggers, etc.) using our Data Acquisition Software (Part Number TEC99923).
Part Number TEC99930

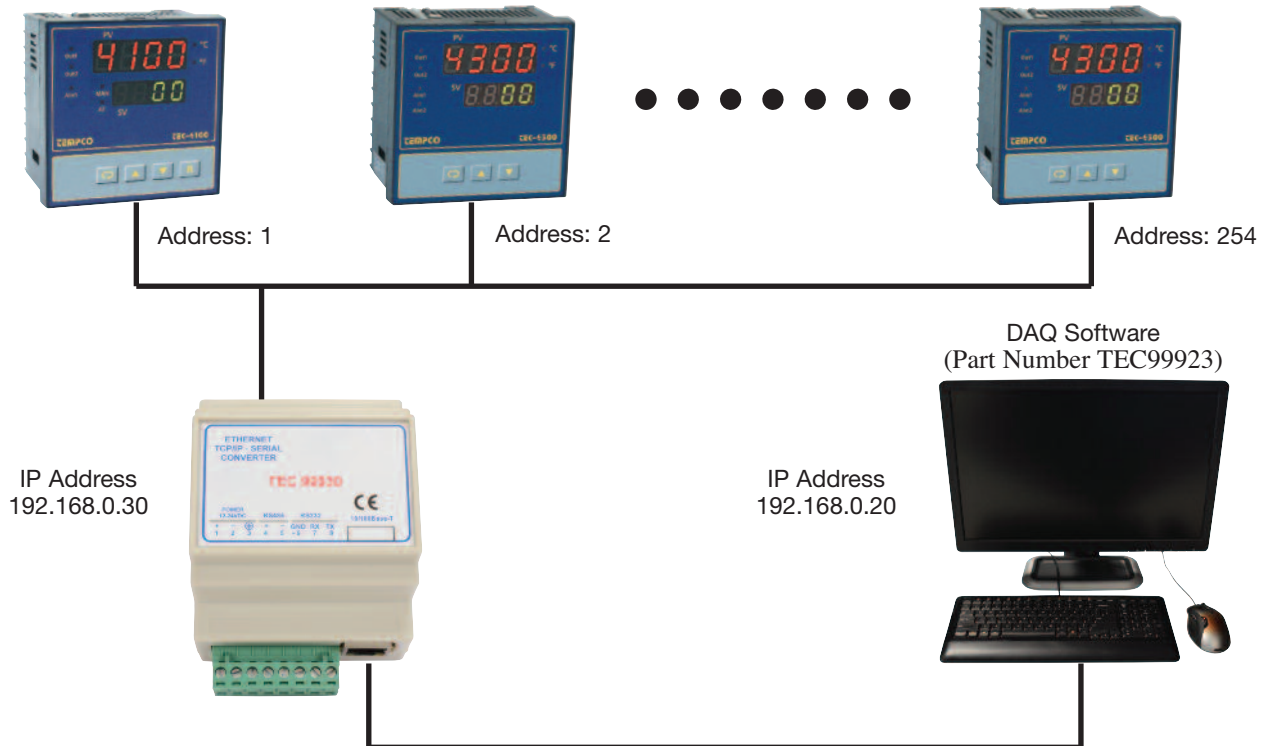

Design Features

- * *Serial to Ethernet communication*
- * *DIN Rail/Panel Mount*
- * *COM1: RS232/RS485, RJ45 for Ethernet connectivity*
- * *Application: Connects IO modules, controllers, and HMIs to an Ethernet Network*
- * *Function: Transparent data link or Gateway to convert Modbus RTU to Modbus TCP messages*
- * *Supports Multiple sockets and enables up to 4 Masters to communicate with slaves connected to PC-E converter*
- * *Web server for Configuration*

Specifications

- Power Supply:** 90mA @ 10VDC / 40mA @ 26VDC
- Ethernet:** 10/100 Mbits, Connector RJ45
- Maximum Ambient Temperature:** 257°F/ 125°C
- Serial:** RS232, 3 Wire, TX, RX & GND
 RS485, 2 Wire Multi drop twisted pair
 Baud Rate 2400, 4800, 9600, 19200, 38400, 57600, 115200
 Communication Settings Data Bits: 5, 6, 7, 8
 Parity None, Even, Odd
 Stop Bits 1, 2
- Operating Temperature:** -10°C to + 50°C
- Storage Temperature:** -40°C to + 85°C
- Connectors:** Power and Communication: 8 way screw connector
- Protection Class:** IP20
- Humidity:** Up to 95% non-condensing

Temperature Controllers



Encapsulated Temperature Controller

Series TKZ Encapsulated Temperature Controller

Shown with
Optional Dial & Knob
with 24" Cord Length

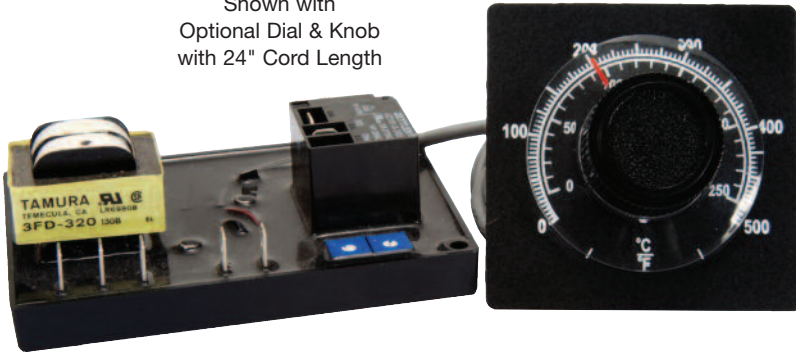

Typical Applications

- Appliances
- Commercial Cooling
- Cooking Equipment
- Environmental Chambers
- Gas Analyzers
- Hot Stamping Machines
- Laboratory Baths
- Packaging Machines
- Refrigerators and Freezers
- Water Heaters

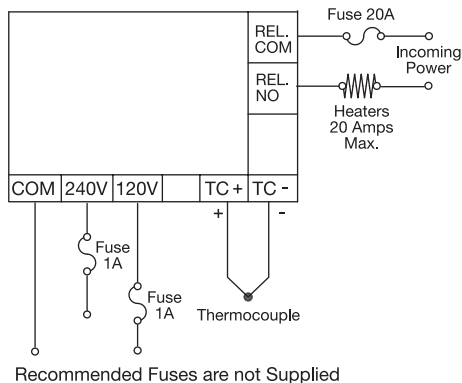
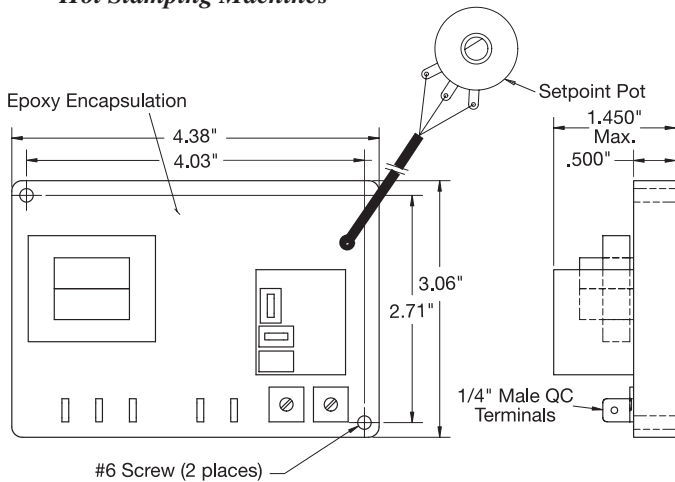

Tempco's Series TKZ temperature controllers' small size and low cost make them ideal for OEM applications or thermostat replacement requiring the accuracy, reliability and versatility only available in an electronic control. The control incorporates highly reliable state-of-the-art analog electronic circuitry in a very economical open board, potted design.

Design Features

- * *The Encapsulated Design allows for use in areas of high humidity and components are less likely to be damaged in handling*
- * *1/4" Quick Disconnect terminals make installation a snap*
- * *Heavy duty 30 Amp (UL rated 20 Amp) relay output*
- * *Compact footprint can easily fit into most commercial or industrial equipment: 3.625" x 2.625" (92 x 67 mm)*
- * *120/240VAC Field Selectable*
- * *Local, remote or fixed setpoint*

Specifications

- Power Input:** 120/240 VAC $\pm 10\%$, 50/60 Hz
- Control Output:** 30 Amp SPST Relay, UL rated 20 Amp, rated for 100,000 cycles
- Control Mode:** On-Off with 4° hysteresis typical; contact factory for other hysteresis values
- Cold Junction Compensation:** Automatic
- Sensor Fault Protection:** Output de-energizes (contacts open) on thermocouple break
- Ambient Operating Temperature:** 0 to 70°C
- Field Wiring Terminals:** .250" male quick connects
- Agency Approvals:** UL and C-UL Recognized

Stock Controllers

All controls listed below have 120/240 input voltage, remote setpoint with 24" leads and a 30 Amp (UL rated 20 Amp) relay output.

Part Number	Signal Input	Dual Range
TKZ10001	J tc	32 to 500°F/0-260°C
TKZ10002	J tc	32 to 1000°F/0-550°C
TKZ10003	K tc	32 to 500°F/0-260°C
TKZ10004	K tc	32 to 1000°F/0-550°C
TKZ10205	K tc	32 to 175°F/0-80°C

Stock Dials and Knobs (Dual Range °C/°F)

Part Number	Dual Range
TKZ99001	32 to 500°F/0-260°C
TKZ99002	32 to 1000°F/0-550°C

Ordering Information

Choose a Part Number from the stock list. Tempco also welcomes large volume OEM inquiries for TKZ controls built to your specific requirements (50 pc. minimum).

WARNING: Cancer and Reproductive Harm - www.P65Warnings.ca.gov.

View Product Inventory @ www.tempco.com

"Infinite" Heat Switch for Open Loop Temperature Control

The Infinite Heat Switch is a unique control designed to modulate power to the resistive load without feedback, open loop style. Rotating the dial clockwise increases the modulated/cycle power delivered to the load.

The control contains a heat sensitive bimetal switch which regulates the running cycles. The bimetal blade has a resistance wire heater wrapped around it which is connected in parallel with the heater load being controlled and is cycled in unison with the heater load. A second bimetal is used as an ambient temperature compensator to neutralize the effect of the surrounding temperature.

Rotate the dial to an ON position and the contacts close for the load and resistance wire. The resistance wire heats up, causing the bimetal blade to flex, opening the contacts. The bimetal blade cools off, the contacts close and the cycle repeats.

The dial position determines the on to off cycle rate.

An optional pilot lamp terminal is connected in parallel to the heater load circuit to indicate when power is connected to the heater load.

The controls are position sensitive. The top is clearly marked on the back of the housing.

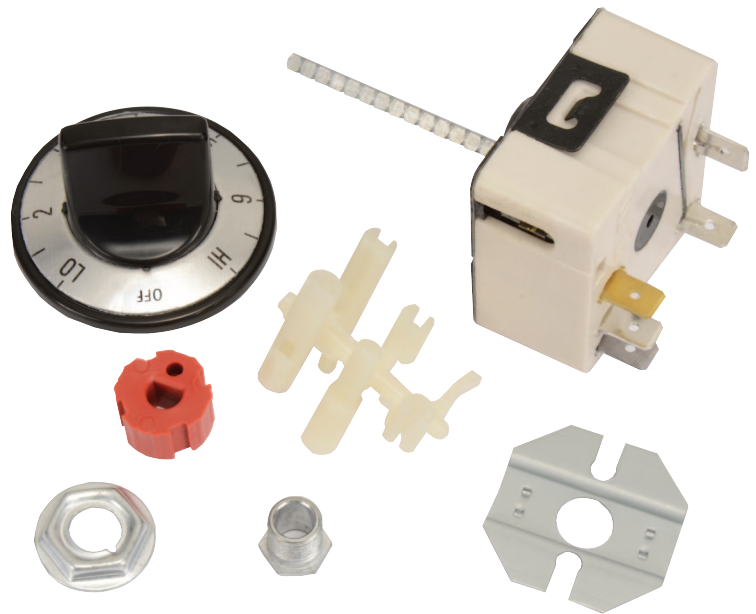

Typical Applications

- ➔ *Cooking Appliances*
- ➔ *Hot Plates/Platens*
- ➔ *Space Heaters*
- ➔ *Glue Pots*
- ➔ *Simple Ovens*
- ➔ *Electric Grills*

Specifications

Electrical Rating: 15 Amps, Resistive

Voltage: 120 or 240 VAC, ±10%

Maximum Ambient Temperature: 257°F/ 125°C

Three Indexing Positions: Off

Low: 5%
High: 100%

Duty Cycle: Nominal 15-20 seconds

Shaft: 1.812 long, square with break off grooves

Rotation: Clock, full 360°

Mounting: Hardware included for screw or bushing mount

Knob: Black with white markings: HI-OFF-LOW, 2-6
Kit includes adapters for use with other knobs

Terminals: 1/4" male spade quick disconnects (5)

Dimensions: 1.75" x 1.75" x 1.45" thick + shaft length

Agency Approval: UL

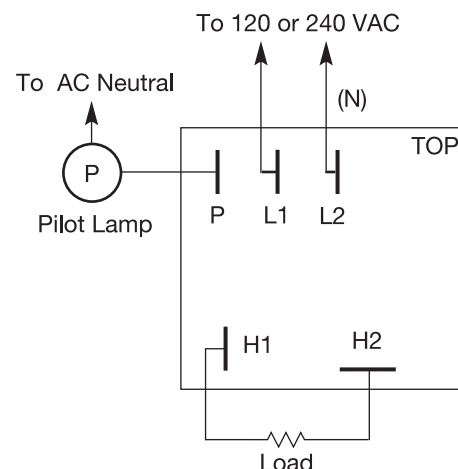

Optional Pilot Lamp Wiring (not included):

- For 120V application with 120V lamp, connect to P and L2.
- For 240V application with 120V lamp, connect to P and ground.
- For 240V application with 240V lamp, connect to P and L2.

Part Number: 120V HSC10001
240V HSC10002

Includes: control unit, knob, break off shaft, mounting and knob hardware.

Benchtop Point-of-Use Temperature Control Consoles

CONSOLE TYPES

2

Type 1—Self-Powered “Plug & Play” Output

Heater power is drawn from console input power.
Maximum current available for heaters: 12 Amps/console
Optional models available to 16 Amps

Construction Characteristics

Tempco TPC Portable Temperature Control Consoles are quality built self-contained systems for monitoring and controlling process temperatures in a wide range of fixed or portable applications.

These 1- to 4- zone units use our reliable next generation TEC-9400 1/16 DIN auto-tuning fuzzy logic PID temperature controllers with user-friendly programming and bright LCD displays using NFPA/IEC standard colors.



Model TPC-1000
1-Zone Control Console
4-7/8" H x 9" D x 5" W



Model TPC-3000
3-Zone Control Console
4-7/8" H x 9" D x 11-1/4" W



Model TPC-2000
2-Zone Control Console
4-7/8" H x 9" D x 8-1/4" W



Model TPC-4000
4-Zone Control Console
4-7/8" H x 10" D x 14-13/16" W

Typical Applications

- ↪ Dryers
- ↪ Platen Heating
- ↪ Ovens and Furnaces
- ↪ Heating of Tanks
- ↪ R & D Laboratory
- ↪ Educational Facilities
- ↪ Packaging Sealing Equipment
- ↪ Semiconductor Processing Equipment

Type 2—Switched Plug Output

Heater power is independent of console input power.
Maximum current available for heaters: 12 Amps/zone

Design Features

- * Front-mounted rocker panel switch
- * Retractable legs for easy benchtop viewing
- * Carrying handle
- * 60-inch-long power cord with standard U.S. straight-blade plug configuration for 120V or 240V. Other country standards available.
- * Miniature jack and plug for temperature sensor input (one per zone)
- * Power output plug (one per zone)
- * Can customize with high limits, alarms, etc.
- * Fast cycling solid state relay

Console Advantages

- * Cost Effective
- * Compact Size
- * Easy to Use
- * Safe to Operate
- * Portable
- * Three Year Warranty



Typical Rear View



NEW DESIGN

Extra Rugged 20 Amp Unit with Mechanical Relay and 12 Gauge 3-Wire Cord

Design Features

- * 2000W/120V, 4000W/240V Maximum load capacity
- * Ideal for Race Teams and Construction Site Heaters
- * Hooded overhang front and rear for protection
- * Plug & Play



Zones	Voltage Input	Controlled Amps	Watts Max.	Part Number Type J Input	Part Number Type K Input
1	120	16	1920	PCM10084	PCM10085
1	240	16	3840	PCM10086	PCM10087

NEW DESIGN

Benchtop Point-of-Use Temperature Control Consoles

TYPE

1

Self-Powered Output (True Plug & Play Operation)

Heater power is drawn directly through the console's 15 amp line cord. Our standard TPC is also fused at 15 amps (12 amps useable). Units fused at 20 amps (16 amps useable) are also available. For these consoles the customer must have access to receptacles rated at 20 amps. For 120 volt operation these are NEMA 5-20, for 240 volt operation these are NEMA 6-20.

True Plug & Play Operation: The heater is simply wired to the supplied plug and plugged in to the rear mounted receptacle.

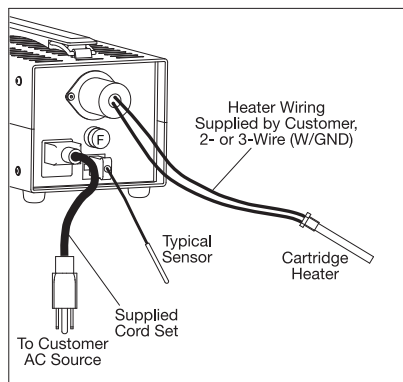

Self-Powered Output Consoles

Heater Power is Drawn from Console Input Power

Zones	Console Voltage Input	Controlled Voltage per Zone	Output per Zone Amps (max)	Watts per Zone (max)	Part Number and Sensor Input		
					Type J Input	Type K Input	RTD Input
1	120	120	12	1440	TPC10062	TPC10063	TPC10064
1	240	240	12	2880	TPC10065	TPC10066	TPC10067
2	120	120	6	720	TPC20051	TPC20052	TPC20053
2	240	240	6	1440	TPC20054	TPC20055	TPC20056
3	120	120	4	480	TPC30024	TPC30025	TPC30026
3	240	240	4	960	TPC30027	TPC30028	TPC30029
4	120	120	3	360	TPC40031	TPC40032	TPC40033
4	240	240	3	720	TPC40034	TPC40035	TPC40036

Stock Items Are Shown In **RED**

TYPE

2

Switched Plug Output Only

The heater power is independent of the console controller input power. A Solid State Relay closure is provided per zone for external control switching. Each zone is fused at 15 Amps. External 120, 208 or 240 VAC must be provided to the heater power circuit.



You must install a switch into the heater circuit to disconnect power to the heater output when the console is not in use. The internal solid-state relay should not be relied on to disconnect heater power.

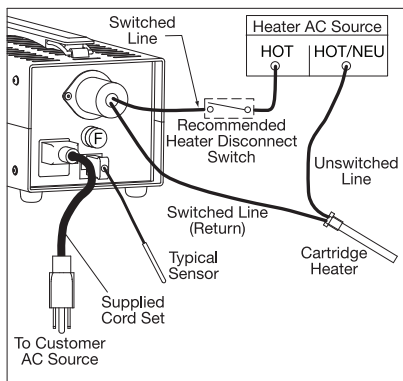

Switched Plug Output Consoles

Heater Power is Independent of Console Input Power

Zones	Console Voltage Input	Controlled Voltage per Zone (max)	Output per Zone Amps (max)	Watts per Zone (max)	Part Number and Sensor Input		
					Type J Input	Type K Input	RTD Input
2	120	240	12	2880	TPC20057	TPC20058	TPC20059
2	240	240	12	2880	TPC20060	TPC20061	TPC20062
3	120	240	12	2880	TPC30030	TPC30031	TPC30032
3	240	240	12	2880	TPC30033	TPC30034	TPC30035
4	120	240	12	2880	TPC40037	TPC40038	TPC40039
4	240	240	12	2880	TPC40040	TPC40041	TPC40042

Specifications

- Output Power Switching:** Solid State Relay with heat sink
- Optional Sensor Inputs:** Consult Tempco
- Power Input:** Rear panel mounted fused power inlet, cord supplied
- Control Options:** FM High Limit Controller, 2nd Output, Alarm, Data Communications or other special requirements; consult Tempco.

Ordering Information

- Standard Consoles** – Order by specifying part number. Standard lead time is Stock to 2 weeks.
- Custom Made Consoles.** Custom consoles can be manufactured with electrical components to meet your specific requirements. **Consult Tempco.**

⚠ WARNING: Cancer and Reproductive Harm - www.P65Warnings.ca.gov.

(800) 323-6859 • Email: sales@tempco.com

PCT Series Thermostat and Temperature Controls

PCT-1000 Series (120 VAC) Bulb & Capillary Type Single-Pole Thermostat



- * 5-foot, 3-conductor line cord
- * 15 Amp straight-blade heater receptacle with ground
- * 3/8" x 4" bulb with 48" long capillary
- * Positive Off detent
- * Heater On pilot light

- * 15 Amp heater fuse
- * Black powder coat metal housing for indoor use
- * Dimensions: 7"H x 3-1/2"W x 3"D (120V units)
9-1/2"H x 3-1/2"W x 3"D (240V units)
- * Wall mounting slots: 6-1/2" centers (120V units)
9-1/2" centers (240V units)

Part Number PCT10001

- * Voltage: 120 VAC (1 Phase)
- * Maximum Wattage: 1440W
- * Temperature Range: 60-250°F

Part Number PCT10003

- * Voltage: 240 VAC (1 Phase)
- * Maximum Wattage: 2880 W
- * Temperature Range: 60-250°F

Part Number PCT10002

- * Voltage: 120 VAC (1 Phase)
- * Maximum Wattage: 1440W
- * Temperature Range: 150-550°F

Part Number PCT10004

- * Voltage: 240 VAC (1 Phase)
- * Maximum Wattage: 2880 W
- * Temperature Range: 150-550°F

PCT-2000 Series — TKZ Encapsulated Electronic Temperature Control



- * Temperature Range: 32-1000°F (0-550°C)
- * 5-foot, 3-conductor line cord
- * 15 Amp straight-blade heater receptacle with ground
- * Heater On pilot light
- * 15 Amp heater fuse

- * Thermocouple mini-jack
- * Black powder coat metal housing for indoor use
- * Dimensions: 7-1/4"H x 3-1/2"W x 3-3/4"D
- * Wall mounting slots: 6-3/4" centers
- * Off switch supplied by customer

Part Number PCT20001

- * Voltage: 120 VAC (1 Phase)
- * Maximum Wattage: 1440W
- * Type J thermocouple jack

Part Number PCT20003

- * Voltage: 240 VAC (1 Phase)
- * Maximum Wattage: 2880 W
- * Type J thermocouple jack

Part Number PCT20002

- * Voltage: 120 VAC (1 Phase)
- * Maximum Wattage: 1440W
- * Type K thermocouple jack

Part Number PCT20004

- * Voltage: 240 VAC (1 Phase)
- * Maximum Wattage: 2880 W
- * Type K thermocouple jack

PCT-3000 Series TEC-2400 Programmable PID Temperature Control



- * 5-foot, 3-conductor line cord
- * 15 Amp heater receptacle with ground
- * 15 Amp heater fuse
- * 1 Amp controller power fuse
- * Heavy duty relay output
- * Thermocouple mini-jack

- * TEC-2400 control with bright LCD Display using NFPA/IEC standard colors
- * Grey polycarbonate housing for use with wall mounting kit
- * Audible alarm
- * Dimensions: 5" square

Part Number PCT30017

- * Voltage: 120 VAC (1 Phase)
- * Maximum Wattage: 1440W
- * Temperature Range: 0-1200°F
- * Type J thermocouple jack

Part Number PCT30019

- * Voltage: 120 VAC (1 Phase)
- * Maximum Wattage: 1440W
- * Temperature Range: 0-2400°F
- * Type K thermocouple jack

Part Number PCT30018

- * Voltage: 240 VAC (1 Phase)
- * Maximum Wattage: 2880 W
- * Temperature Range: 0-1200°F
- * Type J thermocouple jack

Part Number PCT30020

- * Voltage: 240 VAC (1 Phase)
- * Maximum Wattage: 2880 W
- * Temperature Range: 0-2400°F
- * Type K thermocouple jack



PCM-1000 Series Pre-Wired Power Control Boxes (NEMA 12 Indoor Use)



16 Amp Rating

- * TEC-9400 PID temperature control with bright LCD Display using NFPA/IEC standard colors
- * Standard size thermocouple jack
- * 5-foot, 3-conductor line cord
- * 20A straight-blade heater receptacle with ground
- * Fused at 20A
- * 25A mechanical relay
- * Enclosure Dimensions: 6"H x 6"W x 6"D
- * Wall mounting slots: 4" centers side to side, 6-3/4" centers top to bottom
- * Agency Approval: 

Part Number PCM10076

- * Voltage: 120 VAC (1 Phase)
- * Maximum Wattage: 1920 W
- * Temperature Range: 0-1200°F
- * Type J thermocouple jack

Part Number PCM10077

- * Voltage: 240 VAC (1 Phase)
- * Maximum Wattage: 3840 W
- * Temperature Range: 0-1200°F
- * Type J thermocouple jack

Part Number PCM10078

- * Voltage: 120 VAC (1 Phase)
- * Maximum Wattage: 1920 W
- * Temperature Range: 0-2400°F
- * Type K thermocouple jack

Part Number PCM10079

- * Voltage: 240 VAC (1 Phase)
- * Maximum Wattage: 3840 W
- * Temperature Range: 0-2400°F
- * Type K thermocouple jack

24 Amp Rating



- * Temperature Range: 0-2400°F
- * TEC-9400 PID temperature control with bright LCD Display using NFPA/IEC standard colors
- * NO-NC alarm contacts
- * Terminal blocks for incoming power, heater power and universal sensor

- * 32A magnetic contactor
- * BX connectors for sensor, incoming & heater leads
- * Disconnect & 30A heater fusing to be supplied by customer
- * Agency Approval: 

Part Number PCM10080

- * Voltage: 240 VAC (1 or 3 Phase)
- * Maximum Wattage: 5760 or 9970 W
- * Enclosure Dimensions: 10"H x 10"W x 6"D
- * Wall mounting slots: 8" centers side to side, 10-3/4" centers top to bottom

Part Number PCM10081

- * Voltage: 480 VAC (1 or 3 Phase)
- * Maximum Wattage: 11,520 or 19,930 W
- * Enclosure Dimensions: 14"H x 12"W x 6"D
- * Wall mounting slots: 10" centers side to side, 14-3/4" centers top to bottom

48 Amp Rating



- * Temperature Range: 0-2400°F
- * TEC-9400 PID temperature control with bright LCD Display using NFPA/IEC standard colors
- * NO-NC alarm contacts
- * Terminal blocks for incoming power, heater power and universal sensor

- * 65A magnetic contactor
- * BX connectors for sensor, incoming & heater leads
- * Disconnect & 60A heater fusing to be supplied by customer
- * Agency Approval: 

Part Number PCM10082

- * Voltage: 240 VAC (1 or 3 Phase)
- * Maximum Wattage: 11,520 or 19,930 W
- * Enclosure Dimensions: 14"H x 12"W x 6"D
- * Wall mounting slots: 10" centers side to side, 14-3/4" centers top to bottom

Part Number PCM10083

- * Voltage: 480 VAC (1 or 3 Phase)
- * Maximum Wattage: 23,000 or 39,900 W
- * Enclosure Dimensions: 14"H x 12"W x 6"D
- * Wall mounting slots: 10" centers side to side, 14-3/4" centers top to bottom

IMPORTANT: BEFORE TURNING ON POWER, CHECK TIGHTNESS OF ALL ELECTRICAL CONNECTIONS (SOME MAY LOOSEN DURING SHIPPING).

Custom Engineered Process Control Panels



5
Control Panels
Managing
5
Circulation
Heating Systems

Application: Cleaning and applying chromate coating to aircraft parts

Tempco's process controllers provide integrated solutions to manage your thermal loop system.

Why spend your valuable time engineering, designing, sourcing components and building Industrial Power Control Panels? Our UL 508A Certified Panel Shop can meet all your requirements for a multitude of processing control applications, from the simplest single zone panel to the most complex thermal loop system.

We offer general purpose or custom engineered power control panels backed by over 35 years of experience in the process heating industry. We apply our vast knowledge and expertise to every system we design and manufacture.

**Consult us with your requirements.
We welcome your inquiries.**



Custom Designed Portable Heat Treat System

Ramp/Soak Temperature Controllers and other electronics are mounted in a custom sized portable stainless steel cabinet to power silicone rubber electric heating elements.



Panel with Air Conditioner Cooling

This 304 Stainless Steel, NEMA 4X control panel features a thermostat-controlled, side mounted air conditioner that maintains safe interior temperatures for the electrical components while operating in high outdoor ambient temperatures.

Control Panels
are Engineered &
Manufactured in our 508A
Certified Panel Shop.

YOUR SATISFACTION IS GUARANTEED!

Most Items





Application: Outdoor Control Panel for a 1,000 gallon water holding tank with internal temperature control, NEMA 4 construction and enclosure heater



Application: paint curing for decorative landscaping rocks and stone.

Common Designs
See Page 13-58

Custom Designs:
See Page 13-60

Enclosure Types:
See Page 13-63

Obtaining the leading edge process control panel that you need is one thing.

Acquiring it at the cost and time you have in mind is quite another.

**Achieve your goals with TEMPCO.
One Company, One Solution.**



TEMPCO 90KW Skid Mounted Fuel Circulation Heating System

Application: Hot air heating for waste reduction management.
Features: NEMA 4 Control Panel, Purge & Pressurization Enclosure Protection System, TEC-4100 PID Temperature Controller, TEC-410 FM High Limit Control, PPR-1800 Videographic Data Logger, Intrinsically Safe Sensor Barriers

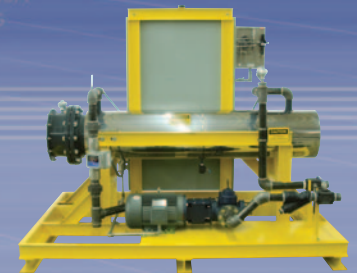

Tempco Power Control Systems:
A Convenient Package For Virtually Any Thermal Loop Application

Temperature Control Panels — Designed for Industrial Process Applications



Design Features

- * NEMA 12 enclosure
- * Model TEC-4400 1/4 DIN or TEC-9400 1/16 DIN temperature control, dual display with auto-tuning and bright LCD displays using NFPA/IEC standard colors
- * Model TEC-410 1/4 DIN or TEC-910 1/16 DIN high limit control with FM approval and manual reset pushbutton switch
- * Main Power: 240 or 480 VAC, single or three phase
- * High limit safety contactor
- * Fused turn handle disconnect
- * Class CC & J fusing offers best-in-class current limitation offering reliable interruption of all overcurrents with protection up to 200kA

Heater Power Output

- SCR output device and fused sub-circuits
- Solid state relays with individual relays per fused sub-circuit
- Mechanical Contactors or optional Mercury relays

These general purpose control panels range in capacity from 4.8KW through 332KW.

They are set up to run process heating systems using circulation heaters, duct heaters or any other resistive load.

All control panels are shipped factory pre-wired according to the National Electrical Code, eliminating the need to design your own control system, purchase separate components and construct your own working temperature control system.

These general purpose temperature control systems are based on SCR power controls, solid state relays or mechanical contactor and are supplied with the standard features listed.

- * Power On pilot lamp
- * Control transformer, fused primary and secondary
- * Power output connections hardwired to fuse holders
- * Sensor input connections hardwired to labeled terminal blocks
- * High quality Hoffman enclosures & components
- * Ventilation fan and filter standard for SCR & SSR systems
- * Tagging of door-mounted parts with 2-color, laser-etched, aluminum labels
- * 1 set of wiring schematics and control manuals
- * Agency Approvals:



Silicon Controlled Rectifier (SCR) Power Controls are solid state devices that provide infinitely variable power to accurately maintain setpoint temperature and extend heater life by maintaining a stable process temperature.

- Single-phase systems use single-phase zero cross SCRs.
- Three-phase systems use 2-leg zero cross or 3-leg phase-angle SCRs dependant on load type.

Solid State Relays offer many of the benefits of SCRs often at a lower cost, but are limited to an 80 Amp load.

Mercury Relays offer a low-cost alternative to SCRs and SSRs for process heating applications and provide longer life than a mechanical contactor due to their self-renewing mercury contacts.

See page 13-61 for some of the more common control panel options.

See page 13-60 for Custom Control Panels



Temperature Control Panels For Industrial Process Applications

Total per Phase Amps	Volts	Phase	Total KW	Number of Fused Sub-Circuits	Part Number with SCR	Panel Size H×W×D (in)	Part Number with SS Relays	Panel Size H×W×D (in)	Part Number with Mechanical Contactors	Panel Size H×W×D (in)
20	240	1	4.8	1	—	—	PCE20001	20×20×8	PCM20001	20×20×8
	480	1	9.6	1	—	—	PCE20002	20×20×8	PCM20002	20×20×8
	240	3	8.3	1	—	—	PCE20003	24×20×8	PCM20003	20×20×8
	480	3	16.6	1	—	—	PCE20004	24×20×8	PCM20004	24×20×8
30	240	1	7.2	1	—	—	PCE20005	24×20×8	PCM20005	24×20×8
	480	1	14.4	1	—	—	PCE20006	24×20×8	PCM20006	24×20×8
	240	3	12.4	1	—	—	PCE20007	24×20×8	PCM20007	24×20×8
	480	3	24.9	1	—	—	PCE20008	24×20×8	PCM20008	24×20×8
60	240	1	14.4	1	PCS20009	24×24×12	PCE20009	30×24×8	PCM20009	24×24×8
	240	1	14.4	2	PCS20010	36×24×12	PCE20010	30×24×8	PCM20010	36×24×8
	480	1	28.8	1	PCS20011	24×24×12	PCE20011	30×24×8	PCM20011	36×24×8
	480	1	28.8	2	PCS20012	36×24×12	PCE20012	30×24×8	PCM20012	24×24×8
	240	3	24.9	1	PCS20013	36×24×12	PCE20013	36×24×8	PCM20013	36×24×8
	240	3	24.9	2	PCS20014	36×24×12	PCE20014	36×24×8	PCM20014	36×24×8
	480	3	49.8	1	PCS20015	36×24×12	PCE20015	36×24×8	PCM20015	24×24×8
	480	3	49.8	2	PCS20016	36×24×12	PCE20016	36×24×8	PCM20016	24×24×8
100	240	3	41.5	1	PCS20017	36×36×12	—	—	PCM20017	36×30×10
	240	3	41.5	2	PCS20018	36×36×12	—	—	PCM20018	36×30×10
	240	3	41.5	3	PCS20019	36×36×12	—	—	PCM20019	42×30×10
	480	3	83.0	1	PCS20020	36×36×12	—	—	PCM20020	42×30×10
	480	3	83.0	2	PCS20021	36×36×12	—	—	PCM20021	42×30×10
	480	3	83.0	3	PCS20022	36×36×12	—	—	PCM20022	42×30×10
150	240	3	62.2	2	PCS20023	42×36×12	—	—	PCM20023	42×30×10
	240	3	62.2	3	PCS20024	42×36×12	—	—	PCM20024	42×30×10
	240	3	62.2	4	PCS20025	42×36×12	—	—	PCM20025	42×30×10
	480	3	124.5	2	PCS20026	42×36×12	—	—	PCM20026	42×30×10
	480	3	124.5	3	PCS20027	42×36×12	—	—	PCM20027	42×30×10
	480	3	124.5	4	PCS20028	42×36×12	—	—	PCM20028	42×30×10
200	240	3	83	2	PCS20029	42×36×12	—	—	PCM20029	42×36×10
	240	3	83	3	PCS20030	42×36×12	—	—	PCM20030	42×36×10
	240	3	83	4	PCS20031	42×36×12	—	—	PCM20031	42×36×10
	240	3	83	5	PCS20032	42×36×12	—	—	PCM20032	42×36×10
	480	3	166	2	PCS20033	42×36×12	—	—	PCM20033	42×36×10
	480	3	166	3	PCS20034	42×36×12	—	—	PCM20034	42×36×10
	480	3	166	4	PCS20035	42×36×12	—	—	PCM20035	42×36×10
	480	3	166	5	PCS20036	42×36×12	—	—	PCM20036	42×36×10
300	480	3	249	4	PCS20037	60×49 ³ / ₄ ×12	—	—	PCM20037	48×36×10
	480	3	249	5	PCS20038	60×37 ⁷ / ₈ ×12	—	—	PCM20038	48×36×10
	480	3	249	6	PCS20039	60×37 ⁷ / ₈ ×12	—	—	PCM20039	48×36×10
	480	3	249	7	PCS20040	60×37 ⁷ / ₈ ×12	—	—	PCM20040	48×36×10
400	480	3	332	5	PCS20041	60×53×12	—	—	PCM20041	42×54 ¹ / ₂ ×10
	480	3	332	6	PCS20042	60×53×12	—	—	PCM20042	42×54 ¹ / ₂ ×10
	480	3	332	7	PCS20043	60×53×12	—	—	PCM20043	42×54 ¹ / ₂ ×10
	480	3	332	8	PCS20044	60×53×12	—	—	PCM20044	42×54 ¹ / ₂ ×10
	480	3	332	9	PCS20045	60×53×12	—	—	PCM20045	60×48×16

Enclosure dimensions are for reference only.



Notes: Control panels that utilize cooling fans require a minimum of 6" clearance on both sides to allow for proper air flow.

Panels designed using Mercury Relays are available on request.

Please specify your 3rd party approval requirements.

Temperature Control Panels **Custom Designed/Manufactured for any Industrial Process Applications**



Typical Design Features

- * *NEMA enclosure*
- * *Choice of temperature controller*
- * *Circuit breaker or fused disconnect*
- * *Main Power: Up to 600 VAC three-phase*
- * *Heater Power: Up to 600 VAC three-phase*
- * *Paperless data logger*
- * *PLC based control with touch panel display*
- * *Fan, heat-tube, air conditioning or other cooling methods*
- * *Anti-condensation enclosure heater*
- * *Twist-lock or jack panel connections available for external connection*
- * *Audible/Visual alarms*
- * *Hazardous Locations*

Tempco's made-to-order control panels are engineered to solve practically every process heating application including zoned infrared arrays for thermoforming and drying ovens. Output power devices can be contactors, SCR, solid state relays or mercury relays. It is recommended that for infrared arrays, only SCRs or solid state relays be used for the most stable element temperature. For halogen (tungsten) elements, phase angle fired SCRs with soft start capability should be used.

All control panels are shipped factory pre-wired in accordance with the National Electrical Code, NFPA79, UL508A and any special local electrical codes required by the customer. UL508A certification available only when requested.

Ordering Information

To request a quote see page 13-62

Custom Temperature Control Panels — Typical Options

- 1. Pre-wired outlets for heater power** Female twist lock style panel mount connectors and male plugs can be added to the exterior of the enclosure for circuits of 480 VAC and 30 Amp and under.
- 2. Pre-wired panel jacks for temperature sensors** Female panel mount jack connectors and plugs can be added to the exterior of the enclosure.
- 3. Other standard voltages** such as 208, 380, 415, 575 or 600 VAC — Special single or three-phase systems can be manufactured to customer requirements.
- 4. Current meter, single phase** A current transformer and a door-mounted analog or digital meter reads the average load current.
- 5. Current meter, three phase** A set of three current transformers, a door-mounted analog or digital meter and a four-position switch allows the customer to read the average load current on all three phases.
- 6. Voltage meter, single phase** A door-mounted analog or digital meter reads the voltage applied to the main input of the control panel.
- 7. Voltage meter, three phase** A door-mounted analog or digital meter and a four-position switch allows the customer to read the voltage applied to the main input on all three phases.
- 8. Optional controls** The standard 1/16th DIN control can be replaced by 1/8 or 1/4 DIN size controls.
- 9. Base—Load—Controller** When used with a zero-fired SCR Power Controller, a base-load-controller can help eliminate light flicker normally associated with large zero-fired loads. High harmonics and low power factor caused by large phase-fired loads can also be improved using a base-load-controller.
- 10. Heater power lamp** Door-mounted pilot lamp gives an indication of applied heater power.
- 11. Circuit breaker instead of main fused disconnect** Replaces the standard fused disconnect with a circuit breaker to provide automatic overcurrent protection.
- 12. Individual sub-circuit circuit breakers instead of fusing** Replaces the standard sub-circuit fusing with internally mounted circuit breakers.
- 13. Annunciation, audible horn** Provides for an audible horn to sound based on the temperature control's alarm condition. An acknowledge pushbutton switch is included. The horn would be mounted on the exterior of the enclosure.
- 14. Annunciation, flashing beacon** Provides for a flashing light to turn on based on the temperature control's alarm condition. An acknowledge pushbutton switch is included. The beacon would be mounted on the exterior of the enclosure.
- 15. Enclosure heater for outdoor use** A silicone rubber heater with thermostat or ceramic bulb enclosure heater to prevent freeze and condensation protection is mounted inside the enclosure. It would be properly sized for the enclosure used.

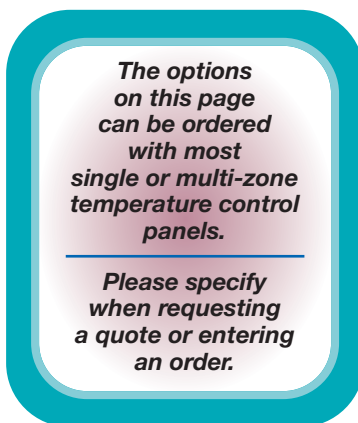

- 16. Mechanical cooling** For control systems that are used in hot environments or require complete enclosure sealing, active or passive cooling can be incorporated into the control panel. This includes cooling fans, air conditioners or vortex cooling.
- 17. Integral liquid level controls** Basic one-level liquid level controls can be incorporated into the safety contactor circuit to turn off the heater if the tank reaches a dangerously low level. Multi-level liquid level switch systems can be incorporated to provide pump or valve controls to maintain required levels.
- 18. Chart recorder** A PPR type data logger recorder (see page 12-2) can be mounted in the door to provide historical data records of the process being controlled.
- 19. Special paint** The enclosure can be custom painted to provide environmental protection or a unique color.
- 20. Tagging internal parts** Engraved phenolic tags can be added to the subpanel to identify components as depicted on the drawings provided. The tags will be attached to the subpanel near the identified part.
- 21. Utility outlet** 120 VAC for maintenance instruments, powered externally or internally. If powered internally, limited to 2 Amps.
- 22. Internal lighting package** A useful option for routine maintenance or troubleshooting.
- 23. Floor stand kit** This option provides a 12" stand kit for any wall-mounted enclosure, making it a free-standing floor model.
- 24. Enclosure mechanical options** Miscellaneous options such as a drip or solar shield can be added to the enclosure.

- 25. Approval drawings** This option is for when the customer requires approval drawings prior to release for manufacturing. (Standard documents are normally shipped with each control panel). With this option, Tempco will provide a copy of the proposed general layout drawing and electrical schematic for customer approval. The production process would not begin until after the *approval drawings* are signed and returned to Tempco.
- 26. HMI Operator Interface** Operator Interface touch screens are available and come pre-programmed by our engineers. A detailed description must be provided by the customer if a custom layout of the HMI is required. Otherwise, general controls and indicators will be included. Works well with or without a PLC option. Available in 4 full color sizes: 4.3", 7", 10" & 15". Built-in paperless data logger included.
- 27. PLC Automation/Process Control** If complex automation is needed, a PLC may be necessary. The PLC will be pre-programmed in-house by our engineering staff. As with the HMI option, a detailed description is required of the customer as to the specifics of the PLC program. Interfaces very well with our HMI option.

Please Consult Tempco if the Option You Require is Not Listed.



Control Panel Quote Request

Temperature Control Panel Quote Request Worksheet

1. General Information: Customer: _____ Date: _____
Contact Person: _____ Phone _____ E-mail: _____
Quote Number: _____ Quote Required By: _____ Salesperson: _____

2. Operating Environment:

Description of Application: _____
Heated Medium (liquid, solid, vapor) & Name _____ Process temperature _____
Installation Environment: indoor, wet, dry _____ NEMA rating _____
Hazardous Location Rating (if required) Class, Division, Group, Zone _____
Minimum & Maximum Ambient Temperatures _____

3. Control Panel Requirements:

Tempco Catalog Number (if applicable) _____ Quantity _____ Drawing Available _____
Any Enclosure Size Limitations _____ Wall Mounted Floor Mounted
Fused Disconnect or Main Circuit Breaker Required Yes No
Number of Controlled Zones _____ Heater Catalog Number _____
Heater Specifications: Watts _____ Volts _____ Phase _____ Amps _____ Number of Circuits _____ Quantity _____
Output Control Device: Magnetic Contactor SCR SSR Mercury Displacement Relay
Temperature Controller Model Number _____ Temperature Controller Sensor Type _____
Maximum Available Short Circuit Current Rating (SCCR) at Panel _____ KA (SCCR requirement)
FM High Limit Required (K t/c standard input) _____ Agency Approval(s) Required _____

4. Other Special Features Required: _____

Ordering Information

**Custom Engineered/Manufactured
Power Control Panels
Available From Tempco.
We Welcome Your Inquiries!**

1. For **Standard Process Control Panels** with the standard list of features, match your heater requirements to the control panels listed on page 13-59. Verify that the number of circuits match between the process heater and control panel and the watts and volts are sufficient.
2. If you require a **Standard Control Panel with Optional Features**, fill out a copy of the Quote Request Worksheet and E-mail it to Tempco. We will review your requirements and return to you a quote for a temperature control system matched to your needs.
3. If you require a **Custom Control Panel**, fill out a copy of the Quote Request Worksheet and fax it to Tempco. Include as much information as you can regarding the heater and application requirements. We will review your requirements and return to you a quote for a temperature control system matched to your needs.

WARNING: Cancer and Reproductive Harm - www.P65Warnings.ca.gov.

Temperature Control Panels — Enclosure Options

Tempco's **Control Panels** are built using NEMA 12 manufactured enclosures. Tempco can also design and manufacture panels to other standard NEMA ratings as described below.

The **Standard NEMA Enclosure Definitions** are listed for your convenience. Also included are comparison charts for indoor and outdoor enclosures.

Include the **NEMA Enclosure Rating** required on your Request for Quote.

Standard NEMA (National Electrical Manufacturers' Association) Enclosure Ratings

Type 1 General Purpose

Enclosures are intended for indoor use primarily to provide a degree of protection against contact with the enclosed equipment in locations where unusual service conditions do not exist.

Type 3 Weather Resistant & Windblown Dust Resistant

Enclosures are intended for outdoor use primarily to provide a degree of protection against windblown dust, rain, and sleet; and to be undamaged by the formation of ice on the enclosure.

Type 3R Weather Resistant

Enclosures are intended for outdoor use primarily to provide a degree of protection against falling rain and sleet, and to be undamaged by the formation of ice on the enclosure.

Type 4 Moisture & Windblown Dust Resistant

Enclosures are intended for indoor or outdoor use primarily to provide a degree of protection against windblown dust and rain, splashing water, and hose-directed water; and to be undamaged by the formation of ice on the enclosure.

Type 4X Moisture & Corrosion Resistant

Enclosures are intended for indoor or outdoor use primarily to provide a degree of protection against corrosion, windblown dust and rain, splashing water, and hose-directed water; and to be undamaged by the formation of ice on the enclosure.

Type 7 Explosion Resistant

Enclosures are capable of withstanding the pressures resulting from an internal explosion of specified gas, and containing such an explosion sufficiently that an explosive gas-air mixture existing in the atmosphere surrounding the enclosure will not be ignited.

Type 12 Resistant to Dirt & Dripping Non-Corrosive Liquids

Enclosures are intended for indoor use primarily to provide a degree of protection against dust, falling dirt, and dripping non-corrosive liquids.

Standard Supplied Enclosure: Type 12

Comparison of Outdoor Rated Enclosures

Provides a degree of protection against the following conditions:	Type of Enclosure			
	3	3R	4	4X
Incidental contact with enclosed equipment	X	X	X	X
Rain, snow and sleet	X	X	X	X
Windblown dust	X		X	X
Hosedown (hose-directed water)			X	X
Corrosive agents				X

Comparison of Indoor Rated Enclosures

Provides a degree of protection against the following conditions:	Type of Enclosure				
	1	4	4X	7	12
Incidental contact with enclosed equipment	X	X	X	X	X
Falling dirt	X	X	X	X	X
Falling liquids and light splashing		X	X	X	X
Dust, lint, and fibers		X	X	X	X
Hosedown (hose directed water)		X	X		
Oil and coolant seepage				X	X
Corrosive agents			X	X	
Potentially explosive gas-air mixture				X	
Windblown dust				X	X

Five-stage heater control panel with PC controlled SCR for Class 8 truck wind tunnel testing.



MX Hot Runner Controls



MX HOT RUNNER

Injection Molding Temperature Control Systems

Improve your injection molding output...switch to Tempco's MX Hot Runner Temperature Control System

The MX System includes:

- ▶ Mainframes
- ▶ 2 types of Temperature Control Modules
- ▶ Cables—Heater Power and Thermocouple
- ▶ Wiring Junction Boxes
- ▶ Input Connectors
- ▶ Floor Stands
- ▶ Accessories

Temperature Control Modules



Tempco's **IMP Series Module** provides one of the most technically advanced temperature controls available today. IMP modules use state-of-the-art microprocessor-based circuitry to perform all required PID functions. Units have built-in diagnostics and are fully self-tuning. Setpoint temperatures are maintained without the need to manually preset or adjust the control temperature. Merely set the desired temperature and turn the power on. The module will automatically sense the heat-up rate and control any setpoint temperature deviation.

Design Features

- * *PID Control*
- * *CompuStep® Soft Start*
- * *CompuCycle®*
- * *Manual Control*

Part Number: TKA20001

Specifications

Temperature Range: Ambient to 999°F (535°C)

Sensor Input: Type J thermocouple

Control Accuracy: ±1.0°F (±0.5°C), dependent on total thermal system

Calibration Accuracy: Better than 0.2% of full scale

Voltage: 240 VAC standard, 120 VAC available

Power Output: 15A @ 240 or 120 VAC 50/60 Hz

Output Switch: Internal zero cross triac

Fusing: High speed fuses on both sides of line

Setpoint Control: Precision 3-digit pushbutton

Manual Power Control: Single turn potentiometer

Mode Control:

3 Positions: Top—Manual mode; Middle—Auto mode; Bottom—Auto mode with soft start

Tempco's **RMB Temperature Control Module** represents the state of the art in Hot Runner temperature control technology. Virtually every feature a moldmaker could want is contained in the module. The RMB's flexible microprocessor-based programming allows the user to modify 17 parameters via the front panel. Once entered, the non-volatile memory automatically saves the parameter modifications.

Design Features

- * *CompuStep®*
- * *CompuCycle® Soft Start*
- * *Easy Start-Up Procedure*
- * *High and Low Deviation Alarms*
- * *Open Thermocouple Error Programming*
- * *Dual Digital Display*
- * *Advanced Diagnostics*
- * *Current Monitor*

Part Number: TKA20005

Specifications

Temperature Range: 32 to 999°F (0 to 535°C)

Sensor Input: Type J or K thermocouple, switch selectable

Control Accuracy: ±0.1°F (±0.1°C) dependent on total thermal system

Calibration Accuracy: Better than 0.2% of full scale

Voltage: 115 to 230 VAC, ±10%

Power Output: 15A @ 240 or 120 VAC 50/60 Hz

Output Switch: Internal zero cross triac

Fusing: High speed fuses on both sides of line

Setpoint Control: two buttons—up and down

Manual Power Control: two buttons—up and down

Mode Control:

3 LEDs: Top/Manual mode

Middle—Auto mode

Bottom—Auto mode with soft start



Improve your injection molding output...switch to Tempco's MX Hot Runner Temperature Control System



Mainframes

The configurations illustrated below provide a wide selection of zone capacities to suit almost any control application. The 5, 8 and 12 zone frames use individual frame sections. The 16 through 48 zone frames use 2, 3 or 4 frame sections rigidly fastened together into one prewired integral unit which requires only one main AC power input connection.



Ordering Information

The following mainframes are set up for 15 Amp per zone IMP or RMB control modules, 240 VAC 3-phase 60 Hz power input. Other power configurations are available; consult Tempco for more information.

Standard lead time is 3 to 4 weeks.

Description	Standard
5-Zone	TKA21005
8-Zone	TKA21008
12-Zone	TKA21012
16-Zone	TKA21016
20-Zone	TKA21020
24-Zone	TKA21024
28-Zone	TKA21028
32-Zone	TKA21032
36-Zone	TKA21036
40-Zone	TKA21040
44-Zone	TKA21044
48-Zone	TKA21048



Note: To order a complete Hot Runner Control System the following must be ordered separately:

- Control Modules
- Mainframe
- Power Mold Cable
- Thermocouple Mold Cable
- Mold Wiring Junction Box (if required)

Mainframe Zone Configurations

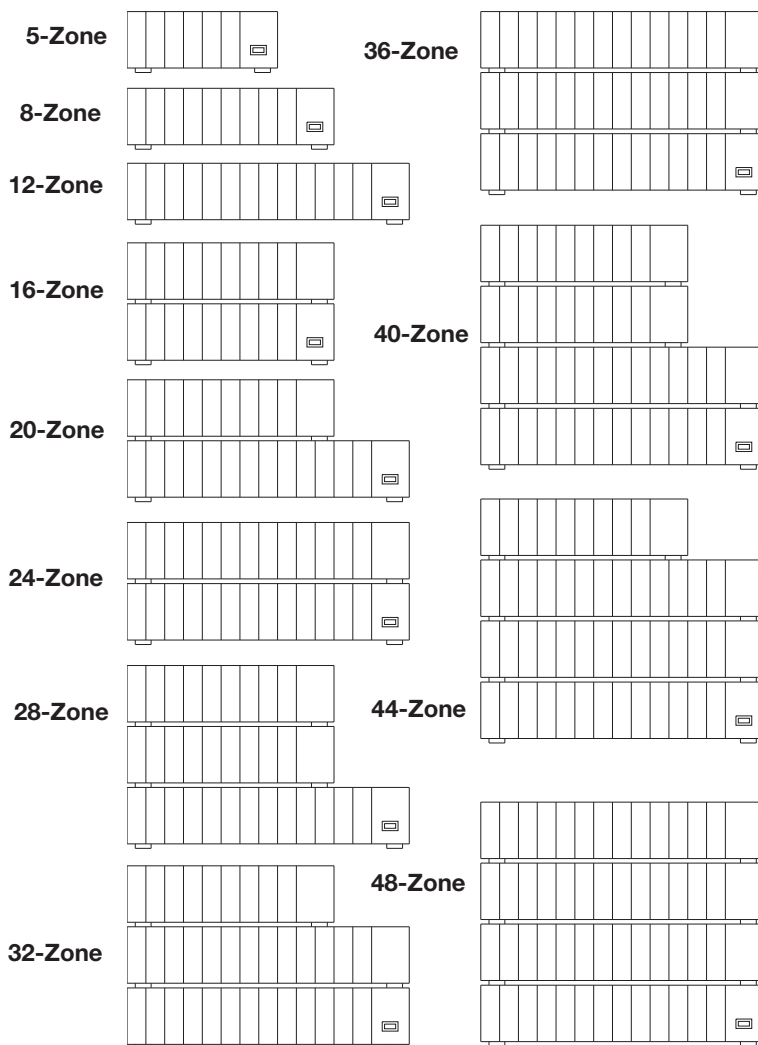

⚠ WARNING: Cancer and Reproductive Harm - www.P65Warnings.ca.gov.



Mold Cables

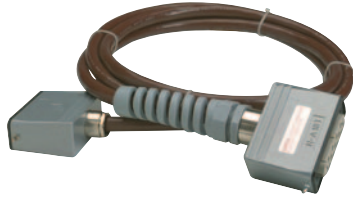

Power Cables

Used to connect the mainframe to the hot runner injection mold for heater power.

Number of control zones	10 ft.	20 ft.
5-Zone	TKA22105	TKA22205
8-Zone	TKA22108	TKA22208
12-Zone	TKA22112	TKA22212



Thermocouple Cables

Used to connect the mainframe to the hot runner injection mold for thermocouple signal.

Number of control zones	10 ft.	20 ft.
5-Zone	TKA23105	TKA23205
8-Zone	TKA23108	TKA23208
12-Zone	TKA23112	TKA23212

Mold Connectors



Power Connector

Used to connect the heater wiring to the power mold cable. Mounts directly on the mold or a wiring junction box.

Part Number	
5-Zone	TKA24005
8-Zone	TKA24008
12-Zone	TKA24012



Thermocouple Connector

Used to connect the thermocouples to the thermocouple mold cable. Mounts directly on the mold or a wiring junction box.

Part Number	
5-Zone	TKA24105
8-Zone	TKA24108
12-Zone	TKA24112

Mold Wiring Junction Boxes

Mold Wiring Junction Boxes are mounted directly on the injection mold. The heaters and thermocouples are wired to the connectors and are ordered separately.

Mold Wiring Junction Box for Power Input Connectors

(for 5-, 8- or 12-zone connectors)

Part Number	"X"	"Y"
TKA25001	4.250"	4.875"

Mold Wiring Junction Box for Thermocouple Input Connectors

Zones	Part Number	"X"	"Y"
5	TKA25005	4.250"	4.875"
8	TKA25008	4.990"	5.614"
12	TKA25012	6.052"	6.676"

Combination Mold Wiring Junction Box for Thermocouple and Power Input Connectors

Zones	Part Number	"X"	"Y"
5	TKA25105	8.031"	8.655"
8	TKA25108	8.843"	9.467"
12	TKA25112	9.906"	10.530"

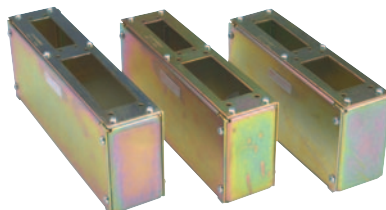
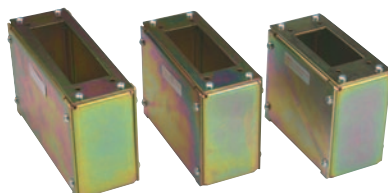
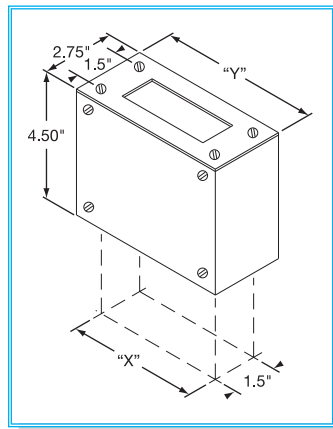
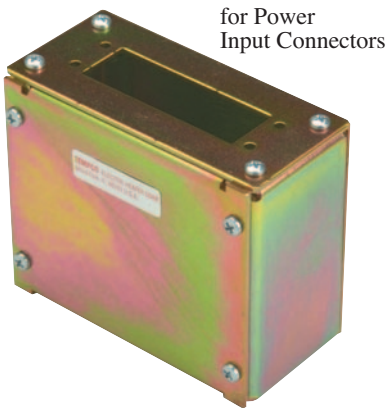

Solid State Variable Power Controllers

Tempco's Solid State Variable Power Controllers are an excellent value for your power controlling needs. Used in an open loop, non-feedback control system, these power controllers regulate input versus output voltage for controlling any of a number of processes where a fixed applied voltage is desired. The solid state technology allows these controllers to be smaller and lighter than ever, and useful in areas where variable voltage transformers are not a viable choice.

Surface Panel Mount 10 Amp Unit

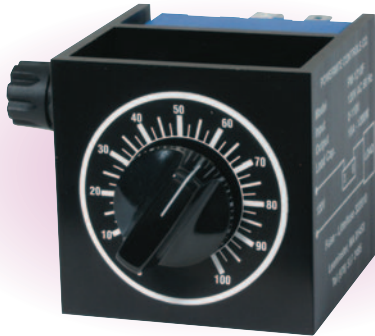

Design Features

- * 2400 Watts @ 240 Volts
- * Compact 2" Cube Size
- * Two-Wire Termination
- * Environmentally Protected
- * 1200 Watts @ 120 Volts
- * One-Hole Mounting
- * High Thermal Efficiency
- * Built-In Fuse for Protection

Part Number 120V: **SRS00010** (Discontinued)

Part Number 240V: **SRS00020**

Specifications

- Input Voltage:** 120V and 240V AC, single phase, 50/60 Hz
- Current Rating:** 10 Amps @ 75°C
- Maximum Load:** 120V-1200 Watts / 240V-2400 Watts
- Output Voltage:** 120V=0 to 118V / 240V=0 to 238V
- Operating Temp. Range:** -40 to 80°C
- Dielectric Insulation:** 1600 Volts RMS @ 80°C for 1 min.
- Control Mode:** Phase Angle

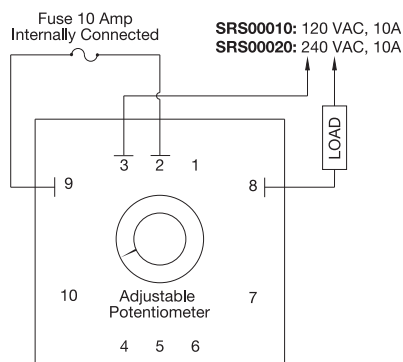

Typical Applications

- ◆ Heaters – Injection and Blow Molding
- ◆ Hot-Runner Mold Cartridge
- ◆ Machine Nozzle
- ◆ Platen Heaters
- ◆ Other Resistive Loads

Recess Mount with Remote Knob 25 Amp Unit

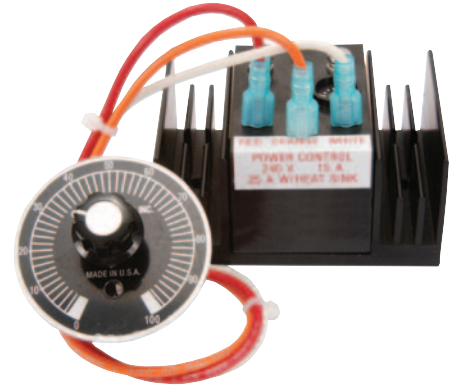

Design Features

- * Solid State Circuit
- * Modified Transient Suppression
- * Remote Mounting Capabilities
- * Knob and Dial Plate
- * Aluminum Heat Sink

Power Controller Part Number: **SRS00030**

Optional Heat Sink Part Number: **SRS00035**

Heat Sink Dimensions: 3" x 5-1/4" x 2-3/8"H (76 x 133 x 60 mm)

Specifications

- Input Voltage:** 120V and 240V AC, single phase, 50/60 Hz
- Current Rating:** 15 Amps, 25 Amps with optional heat sink
- Power Consumption:** 50 Watts (maximum)
- Output Voltage:** Adjustable from 17 to 99% of applied voltage
- Maximum Temperature:** 167°F (75°C) at base plate center
- Dimensions:** 3-1/2" x 2-1/2" x 2-1/8"H (89 x 63 x 54 mm)
- Mounting Centers:** 2-5/8" (137.5 mm)

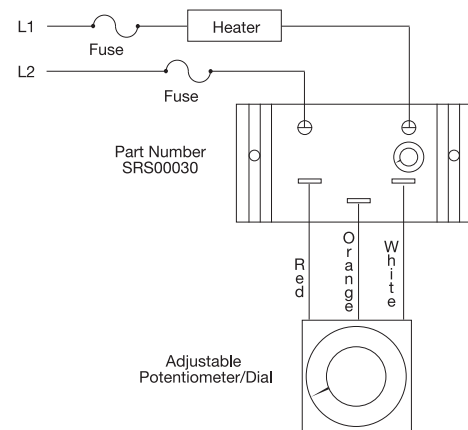

Contract Manufacturing Through Tempco for Electronic OEM Control Systems

*Is your company an OEM that utilizes Electronic Control Systems for the manufacturing of your products?
Are you interested in reducing your costs without compromising quality? Let Tempco help you achieve your goals!*

We can provide you with Electronic Control Systems from Printed Circuit Board Assemblies to Full Blown Sub-Assemblies, including Metal Brackets, Injection Molded Parts, Wire Harnesses and Connectors, through our overseas affiliated manufacturing partners. Taking advantage of the labor rates available globally, Tempco offers extremely competitive prices without compromising quality.

Tempco has had components manufactured internationally for years and has developed a network of qualified affiliated manufacturing partners. Let Tempco assume all of the responsibilities associated with doing business overseas, such as overcoming language barriers, controlling quality, and eliminating problems with payment, importing and shipping.

OEM Advantages of working with Tempco:

- * *Tempco will inventory the product locally*
- * *Contracted delivery for one year or longer*
- * *Just-in-Time shipping schedules*
- * *Uninterrupted supply of product*

In order to develop a quote for your OEM Electronic Control System, Tempco requires submission of a sample and any documentation you have, as described below.

Confidentiality:

To protect your proprietary design information and product, Tempco will sign and honor a Non-Disclosure Agreement with your company.

Limited Sample of Manufacturing Capabilities



Full Range of Standard Test Equipment



Quality Control using Automated Test Equipment in a Clean Room Environment



Environmental Test Chamber for Product Burn-In

Information Required for Quote Request

In order to provide you with a quote on a contract manufacturing project, the following information should be provided to Tempco.

- 1. Physical Sample** – Illustrates how the components of the assembly work together.
- 2. Electronic Design Schematic** – Defines how the components on the PCB are connected together.
- 3. Bill of Material** – Defines all the components used in the assembly from the parts on the PCB to brackets, switches, knobs, etc., in addition to the PCB assembly.
- 4. Written Description of the Product Requirements and Specifications** – Defines the purpose of the assembly.
- 5. Written Description of all Functions and Background Information** – Describes how the product requirements and specifications are to be accomplished.
- 6. Wiring Diagram** – Defines how the assembly fits into the rest of the system.
- 7. Microprocessor Software Source Code** – If the electronic assembly includes a microprocessor (single chip micro industrial computer) there is a software program to make it run, commonly referred to as the "source code." If the source code is not provided,

engineering may be able to "lift" it from the sample for a fee. The source code is usually provided as a file on a disk.

8. Sources and Manufacturer's Part Numbers – A list for any required critical external connectors and required components such as knobs or switches to maintain continuity.

9. Manufactured Mechanical Components – An engineering drawing that defines material, finish, dimensions for overall size, mounting hole locations, etc. for any required sheet metal bracket or faceplate to be manufactured.

10. Artwork – Engineering artwork for any unique silkscreen printing, label or logos involved in the project (if no drawing is provided the sample may be copied).

11. Printed Circuit Board Drawing – An engineering drawing that defines material, overall size, mounting holes, etc.

Any additional information provided to Tempco will assist us in reducing your cost and expediting the project by eliminating engineering time spent on redesigning components.

We Welcome Your Inquiries!

View Product Inventory @ www.tempco.com

Modular Temperature Process Control Boards

Product Examples

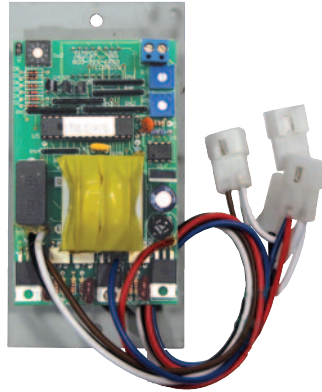

Organic Fuel Cooking Controller

- * *Temperature Adjustment by Selector Switch*
- * *Multiple Outputs for Heater Ignitor, Feed Motor and Ventilation Fan*
- * *3 - Digit LED Display*
- * *Input Connector for 1000 ohm RTD Temperature Sensor*
- * *120 and 240 VAC Versions*

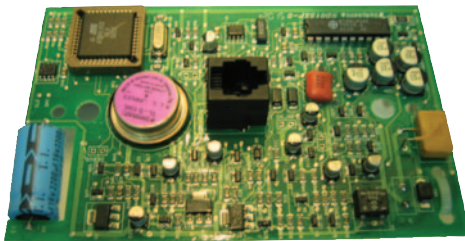

Specialized Industrial Process Controller

- * *PID Temperature Control*
- * *2 Motor Control Outputs*
- * *4 Alarm Relay Outputs*
- * *3 Sensor Inputs*
- * *3 Proximity Switch Inputs*
- * *3 Internal Timer Circuits*
- * *Emergency Modem Connection*

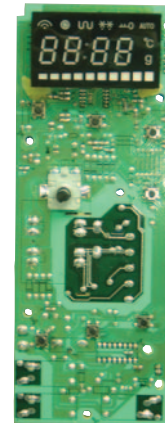

Industrial Equipment Digital Controller

- * *High Precision and Wide Range*
- * *Wide Timer*
- * *LED Display with Clock Setting*
- * *Memory Backup and Auto Resume*

Commercial Furnace Controller

- * *Membrane Switch Front Panel Overlay with LED Windows*
- * *Heat/Temperature Setting*
- * *Fan Speed Setting*
- * *2 Printed Circuit Board Assemblies*
- * *3-Part Injection Molded Housing*
- * *Shipped Completely Assembled*

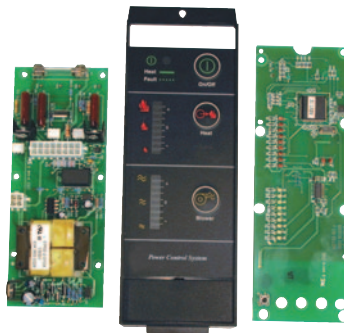

Environmental Test Chamber

- * *Heat or Cool Setting*
- * *Blower Speed Setting*
- * *Digital Temperature Display*
- * *Set Back/Sleep Mode*
- * *Multiple Relay Outputs*



*This represents a small portion of the various products
Tempco has provided to our customers.
We welcome your inquiries!*

Introduction to Silicon Controlled Rectifier (SCR) Power Controllers

Features and Benefits of SCRs

- * **High reliability**
Because the SCR power controller is a solid-state device, it provides virtually limitless, trouble-free operation with a minimum of maintenance.
- * **Infinite resolution**
Power, current or voltage can be controlled from zero to 100% with infinite resolution.
- * **Extremely fast response**
The SCR controller can toggle-load power on and off rapidly, providing the means to respond quickly to command, load and power supply changes.

The SCR

The SCR has two states, *On* and *Off*, and allows current to flow in only one direction. An SCR unit is composed of two SCRs arranged to control AC power. SCRs can remain in the off state even though the applied potential may be several thousand volts; in the on state, they can pass several thousand amperes. When a small signal is applied the SCR will turn on in 10-100 microseconds. Once turned on it will remain on until the current through it is reduced below a very low value called the holding current.

Basically, an SCR power controller consists of the following:

- Semiconductor power devices (SCRs and diodes)
- A control circuit normally referred to as the firing circuit
- A means to dissipate the generated heat
- Protective circuits (fuses and transient suppressors)

True Power Regulation / Current Limit It uses output voltage, current, conduction angle, phase shift, and power factor to monitor and regulate the output. It will provide output power that is constant, regulated and linear to the command signal. This option includes an RMS current limit (adjustable from 35 to 125% of the unit's rating) and has a 0-5 VDC output that is proportional to the load power.

Over-Current Trip Tempco's over-current trip is peak current sensing. The circuit will shut down the SCR within a half-cycle of AC current. It includes an automatic or manual reset that allows the user to select the reset mode after an alarm. A relay output is available for alarming or shutdown. Adjustable from 100 to 300% of the unit's rating.

RMS Current Regulation / Over-Current Trip It will hold the output current constant regardless of the load resistance, based upon the command signal input. This option includes an RMS current trip adjustable from 35 to 125% of the unit's rating.

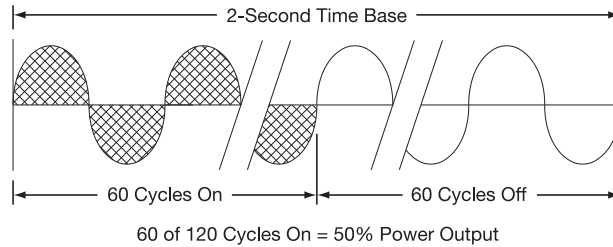

Distributive Zero-Cross Control

The term zero-cross or synchronous operation of SCRs is derived from the fact that the SCRs are turned on only when the instantaneous value of the AC sinusoidal waveform is zero. Zero-cross controllers can provide two rather distinctively different types of control: time proportioning control, and distributive control.

The Distributive Control Technique combines power pulses of short duration to obtain the exact power level proportional to the command signal or setpoint.

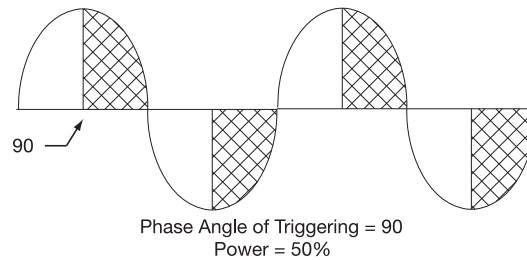

Phase-Angle Control

In phase-angle control the SCR unit is turned on at a certain phase angle of the AC power supply that provides the correct percentage of power. Power is regulated by advancing or delaying the point at which the SCR is turned on within each half cycle. Shown is an example of this for 50% power output.

Phase-angle control provides a very fine resolution of power and is used to control fast responding loads such as tungsten-filament lamps or loads in which the resistance changes as a function of temperature. Phase-angle control is required if the load is transformer-coupled or inductive.

Phase-angle controllers are typically more expensive than zero-cross controllers because the phase-angle circuit requires more sophistication than a zero-cross circuit. Phase-angle control of three-phase power requires SCRs in all three legs and is appreciably more expensive than zero-cross control, which only requires SCRs in two of the three legs.

Optional (SCR) Features

RMS Current Limit / Over-Current Trip The output current can be adjusted to automatically limit or clamp the maximum RMS current available from the SCR power control. It is settable from 35 to 125% of the unit's rating. This option includes an RMS current trip adjustable from 35 to 125% of the unit's rating.

Over-Temperature Thermostat These are bi-metal snap action thermostats that open or close when the heat sink's temperature exceeds its maximum operating temperature. Standard on all SCR power controls starting at 90 Amps. Specify NO or NC when ordering, or a NO thermostat will be included.

Load Unbalance Alarm The unbalance alarm monitors and compares the current in each of the three phases. If the current deviates more than the setpoint allows, an alarm relay is actuated.

SCR Module Failure Alarm This option monitors the voltage drop across each of the SCRs. Since most SCRs fail shorted (zero voltage drop) this is the most accurate method to detect a failed SCR module. A relay output is provided.



SCR Power Controller "A" Series — Single Phase 15 through 70 Amp

Design Features

- * Electrically Isolated Heat Sink
- * Conservative Thermal Design
- * Voltage Squared Linearity
- * Transient Voltage Protection
- * Multi-Turn Zero & Span Adjustments
- * UL, cUL, CE Compliant

The "A" Series SCR Power Controllers are a compact and economical power control solution for industrial applications that require high reliability and long life. The fast solid state switching provides superior performance over relays, contactors and other slower cycling controllers by reducing temperature variations associated with the longer on-off cycles of those devices. The result is a more precise control of the heating process and extended heater life.

- Fast Cycling Distributive Zero Cross or Phase Angle Firing Control Modes
- Line Voltage Compensation
- Compact Size; Diagnostic LED; Increased Heater Life

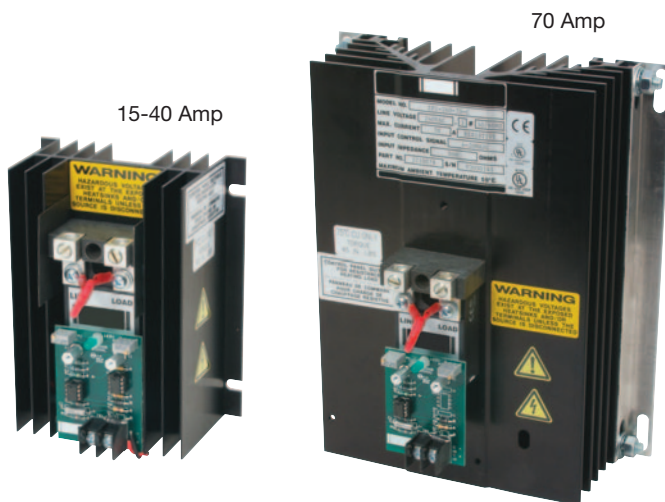

Specifications

Command Signals: 4-20mA; 0-5 VDC; 0-10 VDC; potentiometer

Control Mode: Distributive Zero Cross; Phase Angle Firing

Load Current: 15, 25, 40 or 70 Amps

Line Voltage: 120, 240, 480, or 575 VAC; +10% -20% 50/60 Hz

Zero and Span: Factory pre-set. User adjustable over a range of 20% of span.

Transient Voltage and dv/dt: 200 volts/microsecond minimum. Uses a dv/dt snubber and a metal oxide varistor. (MOV)

Control Range

Zero Cross: 0 to 100% of line voltage

Phase Angle Firing: 0 to 97% of line voltage

Linearity

Zero Cross: Linear with respect to the command signal

Phase Angle Firing: RMS load voltage is linear within 2% of the command signal.

Temperature

Operating: 32 to 122°F (0 to 50°C)

Storage: 14 to 198°F (-10 to 70°C)

Cooling: Convection

Mounting: Panel mount with heat sink fins vertical

Dimensions

15-40 Amp units—Overall: 4.75"W × 6.0"H × 3.1"D

Mounting Centers: 4.35"W × 4.5"H

70 Amp units—Overall: 8.5"W × 10"H × 5"D

Mounting Centers: 8.0"W × 8.75"H

Weight

15-40 Amp units: 1.2 lb.

70 Amp units: 3 lb

Notes: Fusing is not included. Class T fuses are recommended.

All control input configurations require 24 VAC power supply except zero cross with 4-20mA input.



"A" Series SCR Power Controllers are offered with the options listed in the worksheet below. Fill in the boxes with the appropriate number and/or letter designation for your requirements and a part number will be assigned.

Ordering Code: **SRSA** -

Control Mode BOX 1

Z: Distributive Zero Cross
P: Phase Angle Fire

Load Current BOX 2

xx: 15, 25, 40 or 70 Amps

Line Voltage BOX 3

1: 120 VAC
2: 240 VAC
3: 480 VAC
4: 575 VAC

Control Input BOX 4

A: 4 to 20 mA
B: 0 to 5 VDC
C: 0 to 10 VDC
D: Potentiometer

Note: All control input types require additional 24 VAC power input, except zero cross firing with 4-20mA.

Options (up to two) BOXES 5, 6

(for zero cross or phase angle fire models)
E: Over-Temperature Thermostat – N.O. Contacts
F: Over-Temperature Thermostat – N.C. Contacts
N: None
(for phase angle fire models only)
C: RMS Current Limit
J: Over-Current Trip

COMMON CONFIGURATIONS — "A" SERIES 240 VAC; 1-phase; 4-20 mA input

Load Current:	Zero Cross	Phase Angle	Part Number
15 Amp	SRS01101	SRS02101	
25 Amp	SRS01102	SRS02102	
40 Amp	SRS01103	SRS02103	
70 Amp	SRS01104	SRS02104	

Potentiometer Kit (ordered separately): 5KΩ potentiometer and knob
Part number: SRS99001

Multi-Tap Transformer **Input:** 120/240V, 400V, 480V or 575V
Output: 24VAC
Part number: SRS99002

Standard lead time is 2 to 3 weeks.

WARNING: Cancer and Reproductive Harm - www.P65Warnings.ca.gov.

(800) 323-6859 • Email: sales@tempco.com

Temperature Controllers



Single Phase SCR Power Controllers

SCR Power Controller "B" Series—Single Phase 60 through 1200 Amp

The "B" Series SCR Power Controllers are a compact and economical power control solution for industrial applications that require high reliability and long life. The fast solid state switching provides superior performance over relays, contactors and other slower cycling controllers by reducing temperature variations associated with the longer on-off cycles of those devices. The result is a more precise control of the heating process and extended heater life.

Design Features

- * Conservative Thermal Design
- * Compact Size
- * Voltage Squared Linearity
- * Line Voltage Protection
- * Includes Semiconductor I²T Fuses
- * Diagnostic Indicators
- * Multi-Turn Zero & Span Adjustments
- * UL, cUL Compliant



Specifications

Command Signals: 4-20mA; 0-5 VDC; 0-10 VDC; potentiometer

Control Mode: Distributive Zero Cross; Phase Angle Firing

Load current: Zero Cross or Phase Angle Fire Output

Amperage Ratings: 60, 90, 120, 180, 225, 350, 500, 650, 800, 1000, 1200

Line Voltage: 120, 240, 480, or 575 VAC; 10% to 20% 50/60 Hz

Zero and Span: Factory pre-set. User adjustable over a range of 20% of span.

Transient Voltage and dv/dt: 200 volts/microsecond minimum. Uses a dv/dt snubber and a metal oxide varistor (MOV).

Control Range

Zero Cross: 0 to 99.5% of line voltage

Phase Angle Firing: 0 to 97% of line voltage

Linearity

Zero Cross: Linear with respect to the command signal

Phase Angle Firing: RMS load voltage is linear within 2% of the command signal.

"B" Series SCR Power Controllers are offered with the options listed in the worksheet below. Fill in the boxes with the appropriate number and/or letter designation for your requirements and a part number will be assigned.

Temperature

Operating: 32 to 122°F (0 to 50°C)

Storage: 14 to 158°F (-10 to 70°C)

Cooling: 60 Amp convection; all others fan cooled

Mounting: Panel mount with heat sink fins vertical

Dimensions

60-225 Amp units—Overall: 9.5"W × 16.25"H × 9.25"D

Mounting Centers: 7.0"W × 15.69"H

350 and 500 Amp units—Overall: 14.75"W × 20.125"H × 8.5"D

Mounting Centers: 13.0"W × 18.375"H

650 Amp units—Overall: 16.75"W × 23.0"H × 11.5"D

Mounting Centers: 15.75"W × 22.0"H

800-1200 Amp units: Overall: 16.75"W × 29.0"H × 12.0"D

Mounting Centers: 15.75"W × 13.0" Top/15.0" Bottom

Weight

60-225 Amp units: 22 lbs

350-500 Amp units: 24 lbs

600 Amp units: 47 lbs

800-1200 Amp units: 71 lbs

Ordering Code: **SRSB** - 1 2 3 4 5 6 7

Control Mode BOX 1

Z: Distributive Zero Cross
P: Phase Angle Fire

Load Current BOX 2

xxxx: 60, 90, 120, 180, 225, 350, 500, 650, 800, 1000, 1200 Amps

Line Voltage BOX 3

1: 120 VAC
2: 240 VAC
3: 480 VAC
4: 575 VAC

Options (up to three) BOXES 5, 6, 7

(for zero cross models only)

E: Over Temperature Thermostat – Normally Open

F: Over Temperature Thermostat – Normally Closed

(for phase angle fire models only)

A: True Power Regulation / Current Limit

B: Over-Current Trip

C: RMS Current Regulation / Over-Current Trip

D: RMS Current Limit / Over-Current Trip

E: Over Temperature Thermostat – N.O. Contacts

F: Over Temperature Thermostat – N.C. Contacts

N: None

Control Input BOX 4

A: 4 to 20 mA
B: 0 to 5 VDC
C: 0 to 10 VDC
D: Potentiometer



Note: Over-temperature thermostat is standard on 90 Amp controls and over — Specify N.O or N.C. when ordering

Potentiometer Kit (ordered separately): 5KΩ potentiometer and knob – Part Number: **SRS99001**

COMMON CONFIGURATIONS – "B" SERIES

240 VAC; 1 phase; 4-20 mA control input; Includes Over Temperature Thermostat – N.O. for controls 90 Amp and over.

Part Number

Load Current:	Zero Cross	Phase Angle
60 Amp	SRS03101	SRS04101
90 Amp	SRS03102	SRS04102
120 Amp	SRS03103	SRS04103
180 Amp	SRS03104	SRS04104
225 Amp	SRS03105	SRS04105
350 Amp	SRS03106	SRS04106

Standard lead time is 3 to 4 weeks.

WARNING: Cancer and Reproductive Harm - www.P65Warnings.ca.gov.



SCR Power Controller "C" Series — Three Phase 15 through 70 Amp (2-Leg – Zero Cross)

Design Features

- * Electrically Isolated Heat Sink
- * Conservative Thermal Design
- * Voltage Squared Linearity
- * Transient Voltage Protection
- * Multi-Turn Zero & Span Adjustments
- * UL, cUL, CE Compliant
- * Ideal for: Electric Ovens, Furnaces and Kilns, Environmental Chambers and Extruders

The "C" Series SCR Power Controllers are two-leg zero cross SCR power controllers that linearly control, proportional to the command signal, the power applied to a 3-phase electrical load. The controller consists of a master and slave assembly. Each assembly consists of a heat sink and an SCR module. The master assembly contains the control circuit card which controls the on-off cycles for both assemblies.

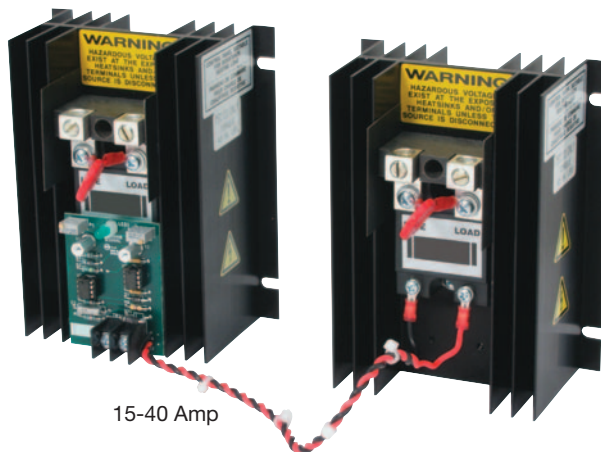

Specifications

- Command Signals:** 4-20mA; 0-5 VDC; 0-10 VDC; potentiometer
Control Mode: Distributive Zero Cross
Load Current: 15, 25, 40 or 70 Amps
Line Voltage: 208, 240, 277, 480 or 575 VAC; 10% to 20% 50/60 Hz
Zero and Span: Factory pre-set. User adjustable over a range of 20% of span.
Transient Voltage and dv/dt: 500 volts/microsecond minimum.
 Uses a dv/dt snubber and a metal oxide varistor (MOV).
Control Range: 0 to 100% of line voltage
Linearity: Average load voltage is linear within 1% of the command signal.

- Temperature**
Operating: 32 to 122°F (0 to 50°C)
Storage: 14 to 158°F (-10 to 70°C)
Cooling: Convection
Mounting: Panel mount with heat sink fins vertical
Dimensions
15-40 Amp units—Overall: 9.61"W x 6.0"H x 3.1"D
Mounting Centers: 4.35"W x 4.5"H (each heat sink)
70 Amp units—Overall: 17.25"W x 10"H x 5"D
Mounting Centers: 8.0"W x 8.75"H (each heat sink)

- Weight**
15-40 Amp units: 2.5 lbs **70 Amp units:** 5.7 lbs

"C" Series SCR Power Controllers are offered with the options listed in the worksheet below. Fill in the boxes with the appropriate number and/or letter designation for your requirements and a part number will be assigned.



Notes: Fusing is not included. Class T fuses are recommended. All control input configurations require 24 VAC power supply except zero cross with 4-20mA input.

Ordering Code: **SRTC** - 1 2 3 4 5

Control Input BOX 1
A: 4 to 20 mA
B: 0 to 5 VDC
C: 0 to 10 VDC
D: Potentiometer

Note: All control input types require additional 24 VAC power input, except 4-20mA.

Load Current BOX 2
xx: 15, 25, 40 or 70 Amps

Line Voltage BOX 3
1: 120 VAC
2: 240 VAC
3: 480 VAC
4: 575 VAC

Options (up to two) BOXES 4, 5
E: Over Temperature Thermostat – N.O. Contacts
F: Over Temperature Thermostat – N.C. Contacts
G: Load Unbalance Alarm
H: SCR Failure Alarm
N: None

COMMON CONFIGURATIONS — "C" SERIES
 240 VAC; 3-phase; 2-leg; Zero cross firing; 4-20 mA input

Load Current:	Part Number
15 Amp	SRT01101
25 Amp	SRT01102
40 Amp	SRT01103
70 Amp	SRT01104

Potentiometer Kit (ordered separately): 5KΩ potentiometer and knob
 Part number: **SRS99001**

Multi-Tap Transformer **Input:** 120/240V, 400V, 480V or 575V
Output: 24V
 Part number: **SRS99002**

Standard lead time is 2 to 3 weeks.

WARNING: Cancer and Reproductive Harm - www.P65Warnings.ca.gov.

(800) 323-6859 • Email: sales@tempco.com

Temperature Controllers



Three Phase SCR Power Controllers

SCR Power Controller "D" Series — Three-Phase 60 through 1200 Amp (2-leg – Zero Cross)

The "D" Series SCR Power Controllers are two-leg zero cross SCR power controls that linearly control, proportional to the command signal, the power applied to a 3-phase electrical load.

The Series "D" controller features a compact design, a single plug-in circuit card for ease of operation and an electrically isolated heat sink. All three leads are fused.

Design Features

- * Back to Back SCRs
- * Includes 3 Semiconductor P²T fuses
- * Line Voltage Compensation
- * Diagnostic Indicators (Control Power, Command Signal, Blown Fuse)
- * Fan Cooled on 90 Amp and higher units
- * Transient Voltage Protection
- * Voltage Squared Linearity
- * Electrically Isolated Heat Sink
- * Multi-Turn Zero & Span Adjustments
- * UL, cUL, CE Compliant

Partial case shown for 60 to 225 Amp units. 350 Amp and up use a caseless, open panel mount design.



Specifications

Command Signals: 4-20 mA; 0-5 VDC; 0-10 VDC; potentiometer

Control Mode: Distributive Zero Cross

Load Current per Leg: 60, 90, 120, 180, 225, 350, 500, 650, 800, 1000, 1200 Amps

Line Voltage: 208, 240, 480 or 575 VAC; 10% to 20% 50/60 Hz

Zero and Span: Factory pre-set. User adjustable over a range of 20% of span.

Transient Voltage and dv/dt: 200 volts/microsecond minimum. Uses a dv/dt snubber and a metal oxide varistor (MOV).

Control Range: 0 to 99.5% of line voltage

Linearity: Average load voltage is linear within 2% of the command signal.

Temperature

Operating: 32 to 122°F (0 to 50°C)

Storage: 14 to 158°F (-10 to 70°C)

Cooling: 60A convection; all others fan cooled

Mounting: Panel mount with heat sink fins vertical

Dimensions

(60 to 225 Amp units use a partial case design. 350 Amp and up use a caseless, open panel mount design.)

60-225 Amp units—Overall: 12.5"W × 16.25"H × 9.25"D
Mounting Centers: 10.0"W × 15.69"H

350 and 500 Amp units—Overall: 19.0"W × 20.125"H × 8.5"D
Mounting Centers: 17.25"W × 18.375"H

650 Amp units—Overall: 24.0"W × 23.0"H × 11.5"D
Mounting Centers: 23.0"W × 22.0"H

800-1200 Amp units: Overall: 27.0"W × 29.0"H × 11.75"D
Mounting Centers: 26.0"W × 13.75" Top/14.25" Bottom

Weight

60-225 Amp units: 31 lbs

350-500 Amp units: 41 lbs

650 Amp units: 87 lbs

800-1200 Amp units: 180 lbs

Ordering Code: SRTD - 1 2 3 4 5

"D" Series SCR Power Controllers are offered with the options listed in the worksheet at right. Fill in the boxes with the appropriate number and/or letter designation for your requirements and a part number will be assigned.

Control Input BOX 1

- A:** 4-20 mA
- B:** 0-5 VDC
- C:** 0-10 VDC
- D:** Potentiometer

Line Voltage BOX 3

- 8:** 208 VAC
- 2:** 240 VAC
- 3:** 480 VAC
- 4:** 575 VAC

COMMON CONFIGURATIONS — "D" SERIES

240 VAC; 3-phase; 2-leg; zero cross firing;

4-20 mA control input; Includes Over-

Temperature Thermostat – N.O. for controls 90 Amp and over

Load Current:	Part Number
60 Amp	SRT02101
90 Amp	SRT02102
120 Amp	SRT02103
180 Amp	SRT02104
225 Amp	SRT02105
350 Amp	SRT02106

Standard lead time is 3 to 4 weeks.

Load Current BOX 2

xxxx: **60, 90, 120, 180, 225, 350, 500, 650, 800, 1000, 1200 Amps**

Options (up to two) BOX 4, 5

- E:** Over-Temperature Thermostat – N.O. Contacts
- F:** Over-Temperature Thermostat – N.C. Contacts
- G:** Load Unbalance Alarm
- H:** SCR Failure Alarm
- N:** None



Note: Over-temperature thermostat is standard on 90 Amp controls and over — Specify N.O or N.C. when ordering

Potentiometer Kit (ordered separately):
5KΩ potentiometer and knob
Part number: **SRS99001**

WARNING: Cancer and Reproductive Harm - www.P65Warnings.ca.gov.



SCR Power Controller "E" Series — Three-Phase 60 through 1200 Amp (3-leg – Phase Angle Fire)

The "E" Series SCR Power Controllers are three-phase, six SCR, phase angle power controls. 5 LEDs monitor line, command signal, 3-line current. They are ideal for electric ovens, furnaces and kilns, silicone carbide, transformer coupled loads.

Design Features

- * Back to Back SCRs
- * Includes 3 Semiconductor I²T Fuses
- * Line Voltage Compensation
- * Diagnostic Indicators (Control Power, Command Signal, Blown Fuse)
- * Fan Cooled on 90 Amp and Higher Units
- * Transient Voltage Protection
- * Voltage Squared Linearity
- * Electrically Isolated Heat Sink
- * Multi-Turn Zero & Span Adjustments
- * UL, cUL, CE Compliant

Partial case shown for 60 to 225 Amp units. 350 Amp and up use a caseless, open panel mount design.

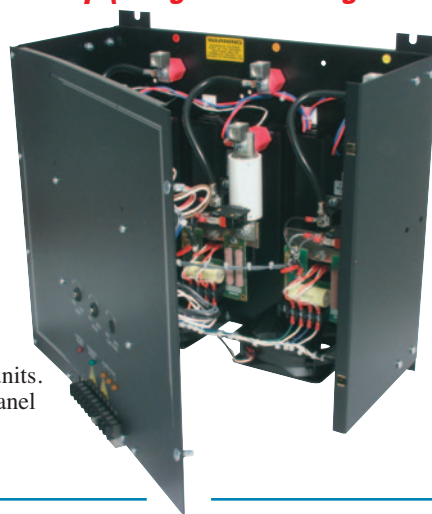

Specifications

- Command Signals:** 4-20 mA; 0-5 VDC; 0-10 VDC; potentiometer
- Control Mode:** 3-Leg – Phase Angle Fire
- Load Current:** 60, 90, 120, 180, 225, 350, 500, 650, 800, 1000, 1200 Amps
- Line Voltage:** 120, 208, 240, 380, 415, 480 or 575 VAC; 10 to 20% 50/60 Hz
- Zero and Span:** Factory pre-set. User adjustable over a range of 25% of span.
- Transient Voltage and dv/dt:** 200 volts/microsecond minimum. Uses a dv/dt snubber and a metal oxide varistor (MOV).
- Control Range:** 0 to 98% of line voltage
- Linearity:** Average load voltage is linear within 2% of the command signal.
- Options Available:** See Ordering Box
- Temperature**
Operating: 32 to 122°F (0 to 50°C)
Storage: 14 to 158°F (-9 to 70°C)
- Cooling:** 60A convection; All others fan cooled)

Mounting: Panel mount with heat sink fins vertical, or any position if fan cooled

Dimensions

(60 to 225 Amp units use a partial case design. 350 Amp and up use a caseless, open panel mount design.)

- 60-225 Amp units—Overall:** 17.5"W × 16.25"H × 9.25"D
Mounting Centers: 15.0"W × 15.69"H
- 350 and 500 Amp units—Overall:** 19.0"W × 31.0"H × 8.5"D
Mounting Centers: 17.25"W × 14.37" Top/14.37" Bottom
- 650 Amp units—Overall:** 24.0"W × 34.75"H × 11.25"D
Mounting Centers: 23.0"W × 16.25" Top/17.5" Bottom
- 800-1200 Amp units: Overall:** 27.0"W × 38.75"H × 11.75"D
Mounting Centers: 26.0"W × 17.25" Top/20.5" Bottom

Weight

- 60-225 Amp units:** 40 lbs
650 Amp units: 126 lbs
350-500 Amp units: 60 lbs
800-1200 Amp units: 231 lbs

Ordering Code: **SRTE** -

Series "E" SCR Power Controllers are offered with the options listed in the worksheet at right. Fill in the boxes with the appropriate number and/or letter designation for your requirements and a part number will be assigned.

COMMON CONFIGURATIONS – "E" SERIES

240 VAC; 3-phase; Phase Angle Firing;
 4-20 mA control input; Includes
 Over-Temperature Thermostat – N.O.
 for controls 90 Amp and over.

Load Current:	Part Number
60 Amp	SRT03101
90 Amp	SRT03102
120 Amp	SRT03103
180 Amp	SRT03104
225 Amp	SRT03105
350 Amp	SRT03106

Control Input BOX 1

- A: 4-20 mA
- B: 0-5 VDC
- C: 0-10 VDC
- D: Potentiometer

Load Current BOX 2

xxxx: **60, 90, 120, 180, 225, 350, 500, 650, 800, 1000, 1200** Amps

Line Voltage BOX 3

- 1: 120 VAC
- 8: 208 VAC
- 2: 240 VAC
- 3: 480 VAC
- 4: 575 VAC
- 5: 415 VAC

Options (up to three) BOXES 4, 5, 6

- A: True Power Regulation/Current Limit
- B: Over-Current Trip
- C: RMS Current Regulation/Over-Current Trip
- D: RMS Current Limit/Over-Current Trip
- E: Over-Temperature Thermostat – N.O. Contacts
- F: Over-Temperature Thermostat – N.C. Contacts
- G: Load Unbalance Alarm
- H: SCR Failure Alarm
- N: None



Note: Over-temperature thermostat is standard on 90 Amp controls and over. Specify N.O or N.C. when ordering.

Potentiometer Kit (ordered separately):

5KΩ potentiometer and knob
 Part number: **SRS99001**

Standard lead time is 3 to 4 weeks.

WARNING: Cancer and Reproductive Harm - www.P65Warnings.ca.gov.

Bulb and Capillary Thermostats

Thermostat Styles and Selection

Construction Characteristics

This type of control operates by expansion and contraction of a liquid in response to temperature change. Liquid contained within the sensing bulb and capillary flexes a diaphragm,

causing the opening and closing of a snap-action switch. For heating applications the contacts are normally closed and open on temperature rise. See Page 13-77 for typical wiring diagrams.



Style A
Single-Pole Thermostat

- * General purpose thermostat recommended for most applications.
- * Capable of controlling loads from 120V/30A up to 480V/20A

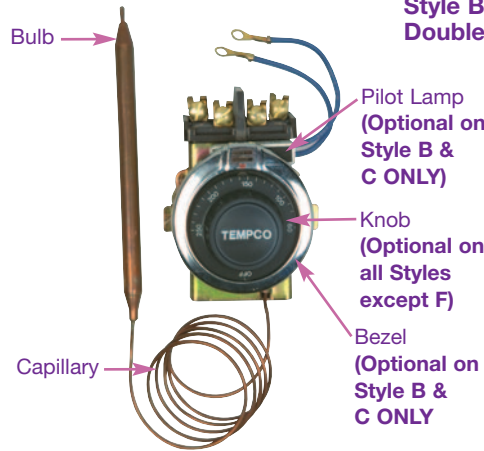

Style B
Double-Pole Thermostat

- * Recommended for directly controlling high wattage loads due to its heavy duty contacts.
- * Capable of controlling loads up to 30 Amps at 277 VAC and 10 Amps at 480 VAC

Thermostat Electrical Ratings: Normally Closed Contacts, Open on Temperature Rise – Adjustable

Stock Items Are Shown In **RED**

Control Type	Style	Temp Range °F	Ampacity at Line Voltage				Bulb Dia. in	Bulb Length in	Capillary Length in	Terminals	Thermostat Part Number	Optional Thermostat Parts			Instruction Sheet P/N
			120V	240V	277V	480V						Knob	Bezel	Pilot Lamp	
SPST	A	60–250	30	30	30	—	0.27	6.00	12	#10 screw	TST-101-137	TST-104-103	n/a	n/a	IDP-119-102
		60–250	30	30	30	—	0.38	4.63	48	#10 screw	TST-101-131	TST-104-103	n/a	n/a	IDP-119-102
		70–245	30	30	15	15	0.25	5.50	12	#10 screw	TST-101-130	Included	n/a	n/a	IDP-119-102
		150–550	30	30	30	—	0.31	5.00	48	#10 screw	TST-101-132	TST-104-109	n/a	n/a	IDP-119-102
		150–560	30	30	30	20	0.33	3.70	12	#10 screw	TST-101-113	TST-104-109	n/a	n/a	IDP-119-102
		200–400	30	30	30	20	0.31	5.00	36	#10 screw	TST-101-121	TST-104-112	n/a	n/a	IDP-119-102
DPST	B	30–110	30	30	30	10	0.38	6.31	36	#10 screw	TST-110-101	TST-104-110	TST-111-101	EHD-109-103	IDP-119-105
		60–250	30	30	30	10	0.38	3.88	18	#10 screw	TST-110-124	TST-104-103	TST-111-101	EHD-109-103	IDP-119-105
		60–250	30	30	30	10	0.38	3.88	24	#10 screw	TST-110-125	TST-104-103	TST-111-101	EHD-109-103	IDP-119-105
		60–250	30	30	30	10	0.38	3.88	36	#10 screw	TST-110-126	TST-104-103	TST-111-101	EHD-109-103	IDP-119-105
		60–250	30	30	30	10	0.38	3.88	60	#10 screw	TST-110-102	TST-104-103	TST-111-101	EHD-109-103	IDP-119-105
		60–250	30	30	30	10	0.38	4.5	156	#10 screw	TST-110-118	TST-104-103	TST-111-101	EHD-109-103	IDP-119-105
		100–550	30	30	30	10	0.38	3.13	24	#10 screw	TST-110-117	TST-104-104	TST-111-101	EHD-109-103	IDP-119-105
		100–550	30	30	30	10	0.38	3.88	48	#10 screw	TST-110-103	TST-104-104	TST-111-101	EHD-109-103	IDP-119-105



- NOTES:**
- Knobs, Bezels and Pilot Lamps are optional and must be ordered separately from the thermostat.
 - Knob TST-104-119 graduated in °C (15-120) is available as an alternate for the standard TST-104-103 knob graduated in °F (60-250).
 - For Thermostat Enclosures refer to page 13-79.

Thermostat Style A (Single Pole—Single Throw)

Typical circuit when voltage and/or line current does not exceed thermostat ratings

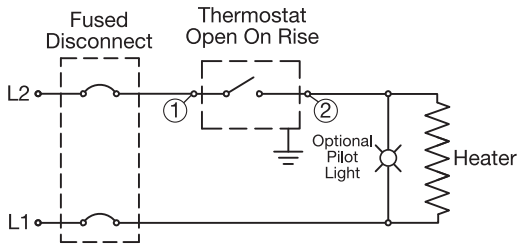

1Ø or 3Ø circuit if line voltage and/or current exceeds thermostat rating

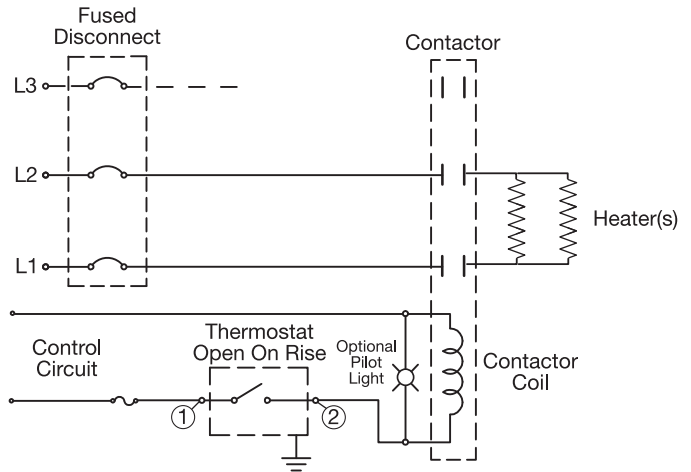

Thermostat Style B (Double Pole—Single Throw)

Typical circuit when voltage and/or line current does not exceed thermostat ratings

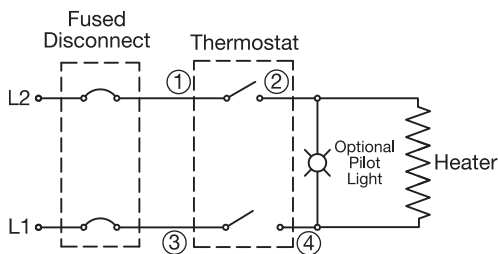

1Ø or 3Ø circuit if line voltage and/or current exceeds thermostat rating

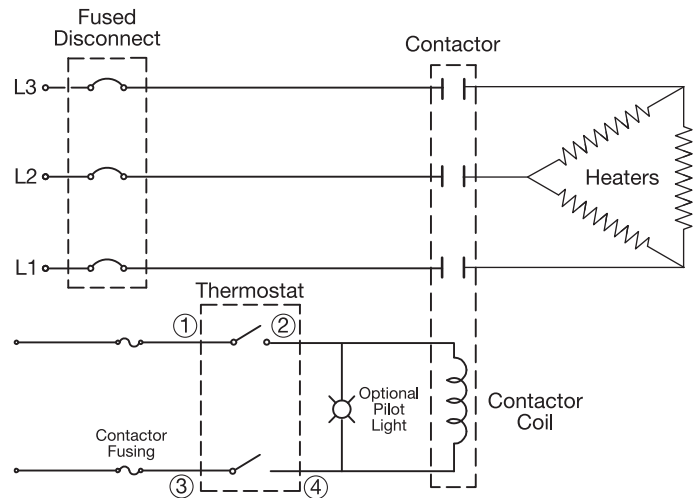

Stock Thermostat Kits

Double-Pole Thermostat Kits include the following components:

Part Number TSTR-1008 with Style B Thermostat	
TST-110-103	Thermostat with 100 to 550°F Range
TST-104-104	Knob
EHD-109-103	Pilot lamp
TST-111-101	Bezel

Part Number TSTR-1009 with Style B Thermostat	
TST-110-102	Thermostat with 60 to 250°F Range
TST-104-103	Knob
EHD-109-103	Pilot lamp
TST-111-101	Bezel

NOTE: Double-Pole Thermostat Kits can also be installed separately from the heater in housing HSGR-1004 shown on page 13-79.

Bulb & Capillary Thermostats

Thermostat Styles and Selection



Style C Double-Pole Thermostat

- * Secondary high limit circuit with manual reset
- * High limit tracks 25°F above setpoint temperature
- * High limit latches open until manual reset is pushed in the event that temperature exceeds 25°F above setpoint
- * Capable of controlling loads up to 30 Amps at 277 VAC



Style D Single-Pole Thermostat

- * General purpose thermostat recommended for most applications
- * Capable of controlling loads up to 25 Amps at 240 VAC

Thermostat Electrical Ratings: Normally Closed Contacts, Open on Temperature Rise – Adjustable

Stock Items Are Shown In RED

Control Type	Style	Temp Range °F	Ampacity at Line Voltage				Bulb Dia. in	Bulb Length in	Capillary Length in	Terminals	Thermostat Part Number	Optional Thermostat Parts			Instruction Sheet P/N
			120V	240V	277V	480V						Knob	Bezel	Pilot Lamp	
DPST	C	60–250	30	30	30	—	0.38	4.50	18	#10 screw	TST-110-127	TST-104-103	TST-111-102	EHD-109-103	IDP-119-106
		60–250	30	30	30	—	0.38	4.50	24	#10 screw	TST-110-128	TST-104-103	TST-111-102	EHD-109-103	IDP-119-106
		60–250	30	30	30	—	0.38	4.50	36	#10 screw	TST-110-129	TST-104-103	TST-111-102	EHD-109-103	IDP-119-106
		60–250	30	30	30	—	0.38	4.50	72	#10 screw	TST-110-113	TST-104-103	TST-111-102	EHD-109-103	IDP-119-106
SPST	D	20–120	25	25	—	—	0.26	4.15	24	6" leads	TST-101-109	TST-104-105	n/a	n/a	IDP-119-101
		40–107	25	25	—	—	0.27	5.88	6	6" leads	TST-101-119	TST-104-102	n/a	n/a	IDP-119-101
		47–107	25	25	—	—	0.32	2.85	8	6" leads	TST-101-106	TST-104-102	n/a	n/a	IDP-119-101
		55–115	25	25	—	—	0.26	3.70	42	6" leads	TST-101-118	TST-104-102	n/a	n/a	IDP-119-101
		60–180	22	22	18	—	0.28	4.20	6	6" leads	TST-101-105	screw adj.	n/a	n/a	IDP-119-101
		60–250	25	25	—	—	0.28	3.00	12	6" leads	TST-101-101	TST-104-101	n/a	n/a	IDP-119-101
SPDT	D	60–250	25	25	—	—	0.26	3.35	70	¼" quick conn.	TST-101-111	TST-104-101	n/a	n/a	IDP-119-101
		60–250	25	25	22	—	0.27	4.10	12	#10 screw	TST-101-116	TST-104-114	n/a	n/a	IDP-119-103

NOTES:

1. Knobs, Bezels and Pilot Lamps are optional and must be ordered separately from the thermostat.
2. Knob TST-104-119 graduated in °C (15-120) is available as an alternate for the standard TST-104-103 knob graduated in °F (60-250).
3. Knob TST-104-105 is a plain pointer knob, not calibrated for the range.
4. Knob TST-104-102 is printed with 4 through 10, not calibrated for the range.
5. For Thermostat Enclosures refer to page 13-79.

Thermostat Style C (Double Pole—Single Throw) with Reset

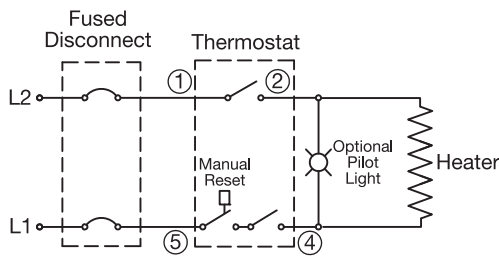

Typical circuit when voltage and/or line current does not exceed thermostat ratings

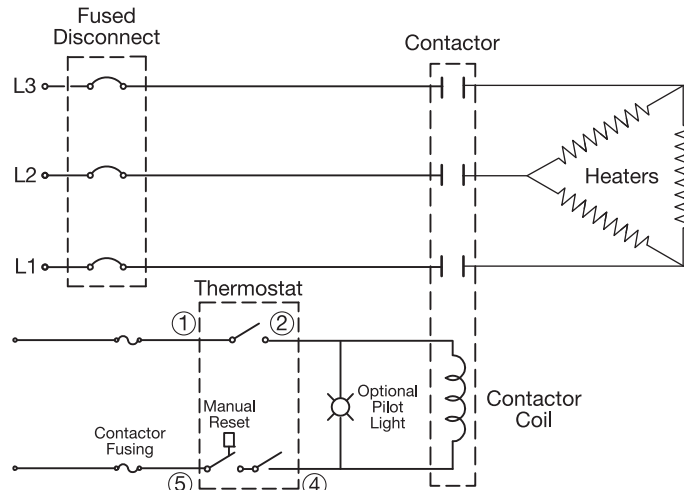

1Ø or 3Ø circuit if line voltage and/or current exceeds thermostat rating

Thermostat Style D (Single Pole—Single Throw)

Typical circuit when voltage and/or line current does not exceed thermostat ratings

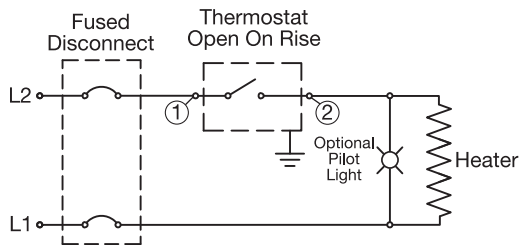

1Ø or 3Ø circuit if line voltage and/or current exceeds thermostat rating

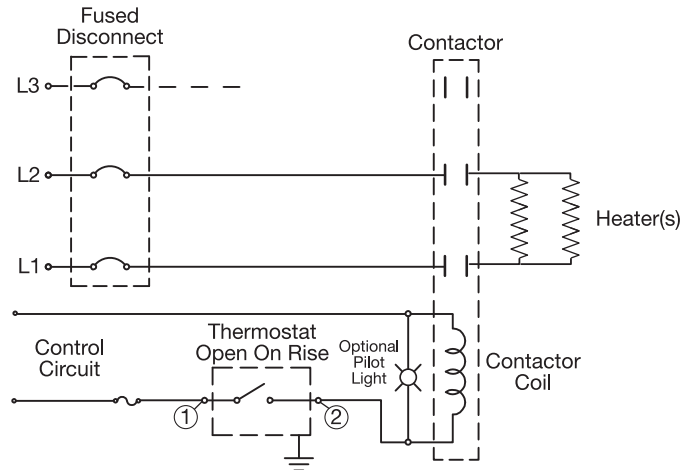

Thermostat Style D (Single Pole—Double Throw)

Typical circuit when voltage and/or line current does not exceed thermostat ratings

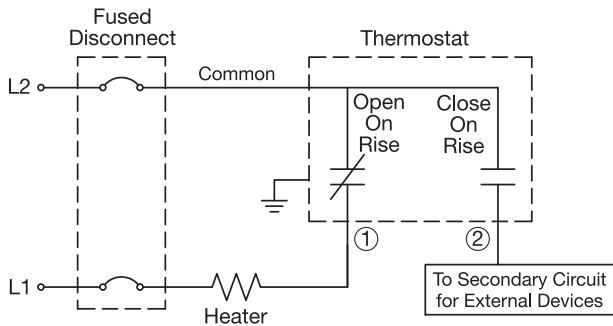

1Ø or 3Ø circuit if line voltage and/or current exceeds thermostat rating

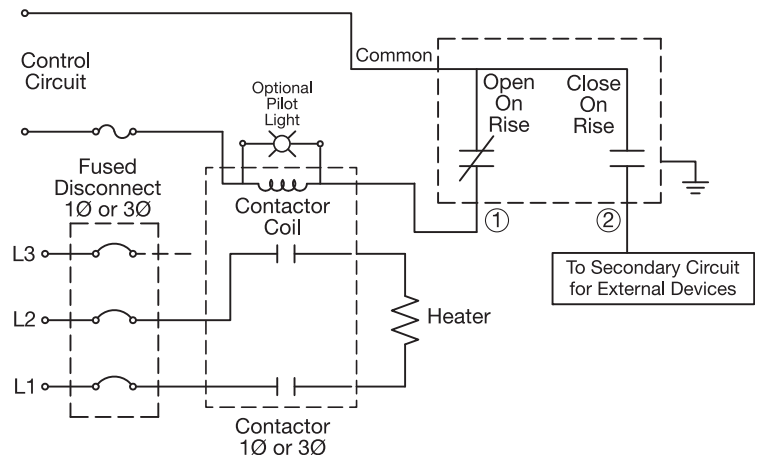

Thermostat Installation Warnings & Recommendations

1. Do not use the thermostat as a power switch. Use some other means of disconnecting power to the heater for servicing.
2. Thermostats are not a fail-safe device. Use an approved high temperature limit control and/or pressure limit control for safe operation.
3. Avoid kinking or bending the capillary tube too sharply as this will alter the calibration and/or render the thermostat inoperable.
4. Excess capillary tube should be coiled neatly in junction box.
5. The capillary tube must never touch the thermostat contacts as this will create an electrical short capable of harming personnel and/or equipment.

Stock Thermostat Enclosures

Thermostats and accessories sold separately



NEMA 1 Enclosure For Single-Pole Style A Thermostats

Size: 4-1/4"H × 3"W × 2"D
with 3/4" trade size knockout
Part Number: **HSGR-1003**



NEMA 1 Enclosure

For Double-Pole Thermostats
Size: 5-3/4"H × 3"W × 2"D
with 1/2" trade size knockout
Used with Style B Thermostats
and Thermostat Kits TSTR-1008
and TSTR-1009 shown on page
13-79.

Part Number: **HSGR-1004**

Style F Temperature High Limit Switch with Manual Reset

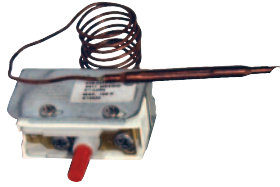

- * General purpose high limit switch with manual reset
- * Once fixed trip point is reached, the high limit switch will remain open until the manual reset button is pushed

Thermostat Electrical Ratings: High Limit – Manual Reset, Normally Closed Contacts, Open on Temperature Rise at Fixed Temperature

Stock Items Are Shown In RED

Control Type	Style	Temp Range °F	Ampacity at Line Voltage				Bulb Dia. in	Bulb Length in	Capillary Length in	Terminal	Thermostat Part Number	Instruction Sheet P/N
			120V	240V	277V	480V						
SPST	F1	118 ±3	30	30	20	20	0.32	3.00	12	#10 screw	TST-103-102	IDP-119-104
SPST	F1	118 ±4	30	30	20	20	0.27	3.35	6	#10 screw	TST-103-109	IDP-119-104
SPST	F1	125 ±2	30	30	20	20	0.25	3.35	36	#10 screw	TST-103-108	IDP-119-104
SPST	F1	165 ±15	30	30	20	20	0.21	2.63	30	#10 screw	TST-103-107	IDP-119-104
SPST	F1	200 ±5	30	30	20	20	0.31	4.00	12	#10 screw	TST-103-104	IDP-119-104
SPST	F1	350 ±8	30	30	20	20	0.25	3.50	36	#10 screw	TST-103-103	IDP-119-104
SPST	F2	420 ±15	30	30	30	30	0.25	4.85	30	#10 screw	TST-103-110	IDP-119-104
SPST	F1	572 ±15	30	30	30	20	0.21	2.63	30	#10 screw	TST-103-106	IDP-119-104

NOTES: F2 style has a side vertical mounting bracket instead of #8 tapped holes for mounting. Refer to IDP-119-104 for mounting details.

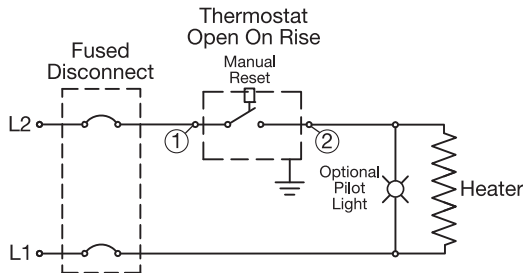

Hi-Limit Thermostat Style F (Single Pole—Single Throw)

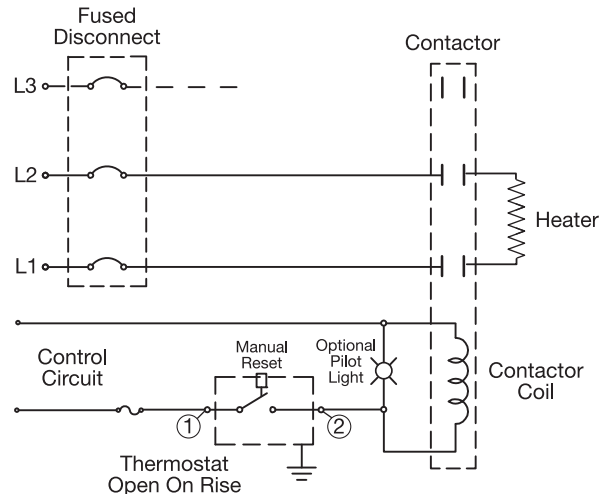

Thermowells (Stainless Steel or Plain Steel)

Welded thermowells provide simple protection for bulb and capillary sensors.

They are supplied with a 1/2" NPT male thread for mounting and a 3/8" NPT internal thread that can be used with the stuffing box assembly to secure the capillary to the well. ID: 0.50", OD: 0.56" See pages 14-76 through 14-83 for thermowells manufactured from bar stock.

Immersed Length in mm	Part Number	
	Steel	Stainless Steel
12	*MPT-120-101	*MPT-121-101
18	MPT-120-102	MPT-121-102
24	MPT-120-103	MPT-121-103
36	MPT-120-104	MPT-121-104

An * indicates a stock item.

Stuffing Box Assembly

The Stuffing Box Assembly is used to seal the thermostat capillary when the sensing bulb (3/8" max. OD) is immersed directly in a liquid rather than in a thermowell. The Stuffing Box consists of six slotted washers used to compress a graphite packing into a 3/8" NPT male pipe thread fitting.

Assembly Instructions

Feed sensing bulb through hole in upper and lower fitting. Insert washers and packing into top cavity of lower fitting. Upper fitting then screws into lower fitting, creating the seal.

Part Number: TST-109-101

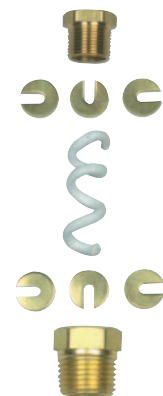



Conduction Type Thermostats B2 Series — Surface Mounted

Tempco Conduction Thermostats do not use only a bonded bimetal strip. The contacts are opened and closed by the expansion and contraction of the base plate in conjunction with the thermal strip. Single pole, single throw contacts open with temperature rise, providing minimum overshoot, smaller cycling differential and faster response to heat load.

Installation Note: The heat-sensitive base plate of the thermostat must be mounted in full contact with the heated surface. This surface should be flat and smooth, and screws should be used for mounting.

Agency Approvals:  File Number E224645

Typical Applications

- ➔ Flat Irons
- ➔ Ironers
- ➔ Deep Fryers
- ➔ Roasters
- ➔ Solder Pots
- ➔ Vulcanizers
- ➔ Sealing Machines
- ➔ Sealing Irons
- ➔ Ovens
- ➔ Hot Plates
- ➔ Industrial and Laboratory Applications

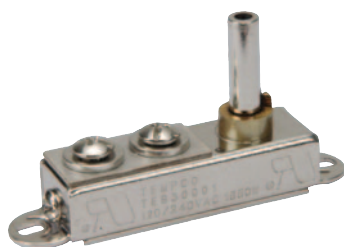

Optional Knob

Part Number: TST-104-118
 Markings: 0-10
 For 1/4" shaft, with set screw
 Material: Phenolic
 0.9" Diameter x 0.667" Height

Standard Models with Shaft

Designed for installation with the base plate in full contact with heated surface. Pre-drilled holes facilitate mounting.

Temperature Range °F (°C)	Amp Rating @ 120 VAC	Amp Rating @ 240 VAC	Overall Shaft Length	Part Number
50 to 525°F (10 to 274°C)	13.75	6.87	1.5"	TEB30001
50 to 425°F (10 to 218°C)	13.75	6.87	1.5"	TEB30002

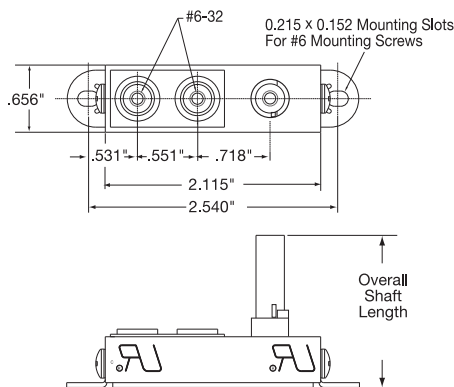

Specifications

Voltage: 120 VAC @ 13.75A / 240 VAC @ 6.87A
Wattage: 1650
Temperature Tolerance: ±5°F / 2.7°C
Operation Range: 50 to 570°F (10 to 300°C)
Wiring: Tapped for #6-32 screws (included)
Endurance: 100,000 cycles

Contact Tempco for your OEM requirements such as special range calibrations or shaft lengths.



Screwdriver Adjustment (optional preset calibration)

Available with factory preset temperature calibration. This feature is optional—if required, specify temperature setting from 72°F (22°C) to 570°F (300°C).

The screw-adjust thermostat is offered in three temperature ranges:

Temperature Range °F (°C)	Pre-Set Tolerance	Amp Rating @ 120 VAC	Amp Rating @ 240 VAC	Part Number
50 to 249°F (10 to 121°C)	±10°F / 6°C	13.75	6.87	TEB32000
250 to 399°F (121 to 204°C)	±15°F / 8°C	13.75	6.87	TEB33000
400 to 570°F (204 to 300°C)	±20°F / 11°C	13.75	6.87	TEB34000

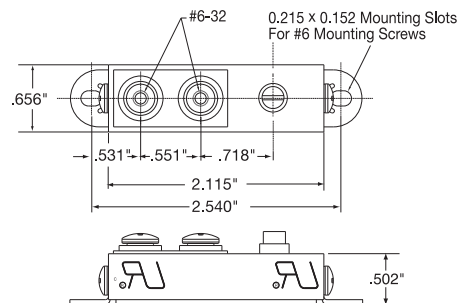

Ordering Information

Choose the **Part Number** of the conduction thermostat that is correct for your application.

For pre-set TEB32XXX, TEB33XXX and TEB34XXX thermostats consult Tempco with your desired setpoint for a Part Number.

All Items Available from Stock

⚠ WARNING: Cancer and Reproductive Harm - www.P65Warnings.ca.gov.

(800) 323-6859 • Email: sales@tempco.com

Surface Mount 1/2" Disc Pre-Set Snap Action Thermostats

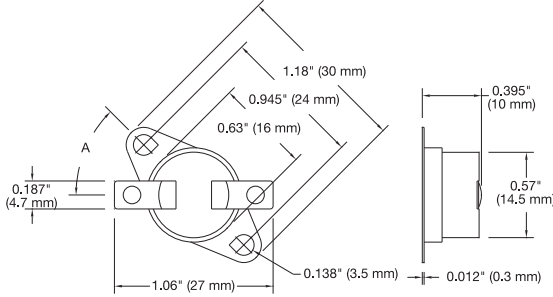

Typical Applications

- Vacuum Cleaners
- Food Service Equipment
- Fireplaces
- Hot Plates
- Laboratory Applications



Construction Characteristics

This line of highly reliable switches utilizes a temperature sensitive disc electrically isolated from the switch. Contacts will open when surface or ambient temperatures increase to the snap point of the calibrated bimetal disc. The entire switch assembly is enclosed in a dust-free housing. The thermostats under 350°F setpoint have a phenolic housing. The thermostats with a setpoint of 350° and over have a ceramic housing. The bimetal disc is retained by a metal heat-conducting end cap.

These thermostats are used in a variety of applications. They are produced in an ISO 9000 certified factory to insure safe and reliable operation. All models are 100% factory inspected for temperature, continuity and function.

Specifications

Electrical Ratings Type S: 125 VAC, 15 Amps, Resistive
250 VAC, 8 Amps, Resistive
100,000 Cycles

Inductive Load Ratings: 120 VAC, 5.8FLA, 34.8LRA
240 VAC, 2.9FLA, 17.4LRA
6,000 Cycles

Operating Temp. Range: 50 to 500°F (10 to 260°C)

Environmental Temp.: 32 to 350°F (0 to 177°C)

Insulation Resistance: 100M ohms or more (500 VDC megger)

Circuit Resistance: 50m ohms or less (initial value)

Dielectric Strength: 1,500 VAC / 1 minute

Approvals: UL, cUL, CSA, VDE, Demko

All Items Available from Stock

Standard Stock Surface Mount Disc Thermostat Temperature Ratings

Open °F	Close °F	Open °C	Close °C	Mounting	Terminals	Dim A	TEMPCO Part Number
50 ±5	32 ±10	10.0 ±2.8	0 ±5.6	Surface Mount	Solder Tab	45°	TST-112-105
60 ±5	40 ±7	15.6 ±2.8	4.4 ±3.9	Surface Mount	Solder Tab	45°	TST-112-106
80 ±5	50 ±9	26.7 ±2.8	10.0 ±5.0	Surface Mount	Vertical, 0.250 quick connect	90°	TST-112-107
95 ±5	77 ±9	35.0 ±2.8	25.0 ±5.0	Surface Mount	Horizontal, 0.250 quick connect	90°	TST-112-142
120 ±5	90 ±10	48.9 ±2.8	32.2 ±5.6	Surface Mount	Solder Tab	45°	TST-112-108
130 ±5	100 ±10	54.4 ±2.8	37.8 ±5.6	Surface Mount	Solder Tab	45°	TST-112-109
140 ±5	110 ±10	60.0 ±2.8	43.4 ±5.6	Surface Mount	Solder Tab	45°	TST-112-101
150 ±5	120 ±10	65.6 ±2.8	48.9 ±5.6	Surface Mount	Solder Tab	45°	TST-112-110
160 ±5	130 ±10	71.1 ±2.8	54.4 ±5.6	Surface Mount	Solder Tab	45°	TST-112-111
175 ±5	145 ±10	79.4 ±2.8	62.8 ±5.6	Surface Mount	Vertical, 0.250 quick connect	45°	TST-112-112
180 ±5	150 ±10	82.2 ±2.8	65.6 ±5.6	Surface Mount	Solder Tab	45°	TST-112-113
190 ±5	160 ±10	87.8 ±2.8	71.1 ±5.6	Surface Mount	Solder Tab	45°	TST-112-114
200 ±5	170 ±10	93.3 ±2.8	76.7 ±5.6	Surface Mount	Solder Tab	45°	TST-112-115
210 ±5	180 ±10	98.9 ±2.8	82.2 ±5.6	Surface Mount	Horizontal, 0.187 quick connect	45°	TST-112-116
230 ±7	200 ±10	110.0 ±3.9	93.3 ±5.6	Surface Mount	Vertical, 0.250 quick connect	90°	TST-112-117
250 ±7	220 ±10	121.1 ±3.9	104.4 ±5.6	Surface Mount	Solder Tab	45°	TST-112-118
300 ±7	220 ±14	148.9 ±3.9	104.4 ±7.8	Rotating Bracket	Vertical, 0.250 quick connect	N/A	TST-112-119
350 ±14	290 ±20	176.7 ±7.8	143.3 ±11.1	Rotating Bracket	Horizontal, 0.187 quick connect	90°	TST-112-120
375 ±14	315 ±18	190.6 ±7.8	157.2 ±10.0	Rotating Bracket	Horizontal, 0.187 quick connect	90°	TST-112-121
392 ±18	194 ±29	200.0 ±10.0	90.0 ±16.1	Rotating Bracket	Horizontal, 0.187 quick connect	90°	TST-112-122
400 ±10	340 ±12	204.4 ±5.6	171.1 ±6.7	Rotating Bracket	Horizontal, 0.187 quick connect	90°	TST-112-123
425 ±15	375 ±20	218.3 ±8.3	190.6 ±11.1	Rotating Bracket	Horizontal, 0.187 quick connect	90°	TST-112-124
450 ±15	370 ±20	232.2 ±8.3	187.8 ±11.1	Rotating Bracket	Horizontal, 0.187 quick connect	90°	TST-112-125
500 ±20	420 ±20	260.0 ±11.1	215.6 ±11.1	Rotating Bracket	Horizontal, 0.187 quick connect	90°	TST-112-126

High Limit Surface Mount Disc Thermostats with Manual Reset

Construction Characteristics

This line of highly reliable switches utilizes a snap-action bimetal disc electrically and thermally isolated from the switch. The contacts are normally closed and open on rise when surface or ambient temperature setpoint is reached. The circuit will remain open until the manual reset button is depressed at approximately 30% below its operating temperature. All models are 100% temperature tested and can be calibrated to your specification at the factory. Many popular settings are available from stock.

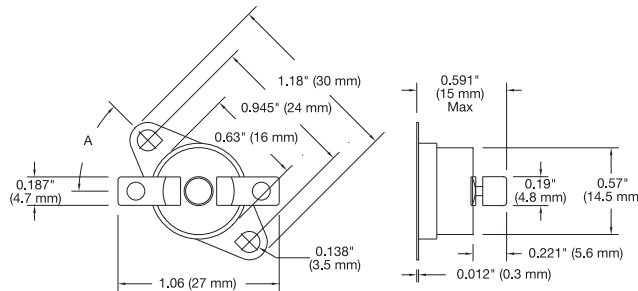

Specifications

- Electrical Ratings Type U:** 125 VAC, 15 Amps, Resistive
250 VAC, 10 Amps, Resistive
6,000 Cycles
- Inductive Load Ratings:** 120 VAC, 5.8FLA, 34.8LRA, 12 Amps
250 VAC, 2.9FLA, 17.4LRA
6,000 Cycles
- Operating Temp. Range:** 50 to 320°F (10 to 160°C)
- Differential:** 15 to 100°F (8 to 56°C)
- Environmental Temp.:** 32 to 350°F (0 to 177°C)
- Insulation Resistance:** 100M ohms or more (500 VDC megger)
- Circuit Resistance:** 50m ohms or less (initial value)
- Dielectric Strength:** 1,500 VAC / 1 minute
- Approvals:** UL, cUL, CSA

Typical Applications

- Vacuum Cleaners
- Food Service Equipment
- Fireplaces
- Hot Plates
- Laboratory Applications

Ordering Information

Choose the **Part Number** of the 1/2" Thermostat from the tables on pages 13-82 and 13-83 that match the needs for your application.

We also offer other styles of 1/2" Thermostats with alternate setpoints. Consult Tempco for availability.

Standard lead time is stock to 3 weeks.

Standard Stock High Limit Manual Reset Thermostats

Open °F	Open °C	Mounting	Terminals	Dim A	TEMPCO Part Number
150 ±10	65.6 ±5.6	Rotating Bracket	Vertical, 0.250 quick disconnect	N/A	TST-115-101
160 ±10	71.1 ±5.6	Surface Mount	Solder tabs	45°	TST-115-102
194 ±10	90.0 ±5.6	Surface Mount	Solder tabs	90°	TST-115-103
212 ±10	100.0 ±5.6	Rotating Bracket	Horizontal, 0.250 quick disconnect	N/A	TST-115-104
250 ±10	121.1 ±5.6	Surface Mount	Solder tabs	45°	TST-115-105
302 ±10	150.0 ±5.6	Surface Mount	Vertical, 0.250 quick disconnect	45°	TST-115-106
320 ±10	160.0 ±5.6	Surface Mount	Horizontal, 0.250 quick disconnect	45°	TST-115-107

Available from Stock



Note: "Rotating Bracket" mounting indicates that the mounting holes can be rotated vs. the solder tabs and for "Surface Mount" they are fixed.

⚠ WARNING: Cancer and Reproductive Harm - www.P65Warnings.ca.gov.

(800) 323-6859 • Email: sales@tempco.com

One Shot Thermal Cutoffs



Design Features

- * *Low Cost*
- * *Excellent Contact Rating*
- * *Quick & Easy Installation*

Typical Applications

- *Personal Care*
- *Appliances*
- *Motors*

Thermal cutoffs are designed to provide upper limit temperature protection for many electronic products. Under normal operating temperature, the solid pellet compresses a spring which holds the star contact against the isolated lead. When a fault temperature is reached, the pellet melts and the circuit is opened permanently.

It is important to allow sufficient time to determine the proper and best location for a thermal cutoff. The location will affect the cutoff's ability to protect your product. Placement in the highest temperature area is usually best. Use a thermal cutoff that is higher than your target operating temperature, as a thermal cutoff is supposed to be a fail-safe to protect the system from catastrophic failure.

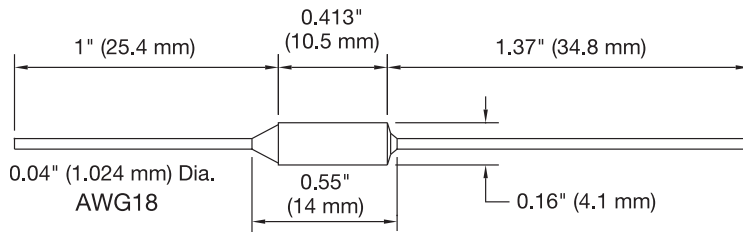

Specifications

Electrical ratings: 120/250 VAC, 10 Amps, Continuous duty
120/250 VAC, 15 Amps, Interrupting current

Temperature tolerance: +0°C/-4°C
(+0°F/-7°F)

Approvals: UL, CSA, VDE

Ordering Information

Choose the **Part Number** of the thermal cut-off that best meets the requirements on your application from the chart above.

Standard lead time is stock to 3 weeks.

Standard Stock Thermal Cutoff Temperature Ratings

Cutoff Temp. °F	°C	TEMPCO Part Number
151	66	TST-106-104
162	72	TST-106-110
170	77	TST-106-111
183	84	TST-106-112
196	91	TST-106-113
208	98	TST-106-114
219	104	TST-106-101
230	110	TST-106-106
250	121	TST-106-107 ^①
262	128	TST-106-109
286	141	TST-106-115
291	144	TST-106-116 ^②
306	152	TST-106-117
333	167	TST-106-105 ^①
363	184	TST-106-119
378	192	TST-106-120
421	216	TST-106-121 ^③
464	240	TST-106-122

Agency Approvals:
UL, CSA, VDE

Exceptions as noted:

- ① No agency approvals
- ② UL and CSA approved only
- ③ VDE approved only

⚠ WARNING: Cancer and Reproductive Harm - www.P65Warnings.ca.gov.

Differential Expansion Cartridge Type Thermostats

Widely Used in Industrial, Scientific and Commercial Temperature Control Applications

Typical Applications

- ✦ Packaging Machinery
- ✦ Laminating Equipment
- ✦ Photographic Processing
- ✦ Hot Stamping
- ✦ Plastic Processing Machines
- ✦ Vending Machines
- ✦ Food Service Equipment
- ✦ Medical & Dental Equipment
- ✦ Code Dating Equipment

Design Features

A

Flexible leads externally connected to terminal pins provide high pull strength, eliminating pulled out leads.

B

Setpoint adjustment allows the setting of the temperature required without transmitting force to the contact mechanism, which can interfere with the accuracy of the unit.

C

Terminals are embedded in fused glass, providing a seal and strain relief to eliminate lead tension that can interfere with the accuracy of the unit.

D

One-piece strut made from low expansion alloy is assembled under tension. The strut and contacts operate by slow make and break, responding to the smallest temperature changes, accounting for quick response and sensitivity to within $\pm 1.0^{\circ}\text{F}$.

E

Wire braid provides the flexibility required in order to withstand the expansion and contraction of the outer shell without interfering with the ability of the unit to handle the load capacity under maximum operating temperature.

F

The expanding shell is the heat sensing component and not just a housing, being responsive to the slightest temperature changes and leading the strut by an interval that varies with the range of temperature.

G

Silver alloy contacts mounted on a one-piece strut. They open and close by the expansion and contraction of the outer shell, instantaneously responding to temperature changes.

H

Heli-arc welded end disc provides a positive seal against moisture and other contaminants.

Temperature Controllers



Cartridge Type Thermostats

Thermostatic Cartridge Type Temperature Controls

Tempco Thermostatic Temperature Controls are proven, simple, sensitive temperature controls with an adjustable setpoint. The sheath is a temperature sensor that responds to the tempera-

ture of its environment by expanding and contracting, thereby mechanically actuating a set of contacts within. Use to accurately control temperature on hundreds of applications.

Specifications

Temperature Range:

1/4" dia. models: -100 to 500°F (-73 to 260°C)
1/2" and 5/8" dia. models: -100 to 600°F (-73 to 315°C)

Tube Shell Diameters:

1/4" dia. model: 0.249" +.000/- .004" actual
1/2" dia. model: 0.499" +.000/- .004" actual
5/8" dia. model: 0.625" +.000/- .004" actual

Contact Action: Slow make and break

External Materials: 304 Stainless Steel

Agency Approvals:



Sensitivity:

1/4" dia. model: As low as 1°F depending on application
1/2" and 5/8" dia. models: As low as 0.5°F depending on application

Accuracy: Dependent on application

Standard Termination:

1/4" dia. model: 8" long - #26 ga silver plated copper with Teflon® insulation
1/2" dia. model: 8" long - #20 ga stranded nickel clad copper with fiberglass insulation
5/8" dia. model: 8" long - #16 ga stranded nickel clad copper with fiberglass insulation

Standard Stock Thermostatic Controls

Insert Dia.	Contact Length	Action on Temp. Rise	Electric Rating (Amp-Volts)	Part Number
5/8"	3 5/8"	Open (NC)	10A@120VAC, 5A@240VAC	TEV01500
		Close (NO)	2A-120 VDC	TEV01501
1/2"	2 1/2"	Open (NC)	5A@120VAC, 3A@240VAC	TEV01400
		Close (NO)	1A@120VDC	TEV01401
1/4"	1 7/8"	Open (NC)	1A@120VAC	TEV01200
		Close (NO)		TEV01201
5/8"	3 7/8"	Open (NC)	10A@120VAC, 5A@240VAC	TEV02500
		Close (NO)	2A-120 VDC	TEV02501
1/2"	2 5/8"	Open (NC)	5A@120VAC, 3A@240VAC	TEV02400
		Close (NO)	1A@120VDC	TEV02401
5/8"	3"	Open (NC)	10A@120VAC, 5A@240VAC	TEV03500
		Close (NO)	2A-120 VDC	TEV03501
1/2"	2"	Open (NC)	5A@120VAC, 3A@240VAC	TEV03400
		Close (NO)	1A@120VDC	TEV03401
1/4"	3/4"	Open (NC)	1A@120VAC	TEV03200
		Close (NO)		TEV03201
5/8"	3"	Open (NC)	10A@120VAC, 5A@240VAC	TEV04500
		Close (NO)	2A-120 VDC	TEV04501
1/2"	2"	Open (NC)	5A@120VAC, 3A@240VAC	TEV04400
		Close (NO)	1A@120VDC	TEV04401
1/4"	3/4"	Open (NC)	1A@120VAC	TEV04200
		Close (NO)		TEV04201
5/8"	3 5/8"	Open (NC)	10A@120VAC, 5A@240VAC	TEV05500
		Close (NO)	2A-120 VDC	TEV05501
1/2"	2 5/8"	Open (NC)	5A@120VAC, 3A@240VAC	TEV05400
		Close (NO)	1A@120VDC	TEV05401
1/4"	1 1/4"	Open (NC)	1A@120VAC	TEV05200
		Close (NO)		TEV05201

Ordering Information

State part number and special features if required. For special Thermostatic Controls, consult Tempco.

- * The 1/2" and 5/8" dia. models are UL recognized.
- * The 5/8" dia. model is CSA certified.
- * Factory pre-set temperature setpoint: specify temperature setpoint.
- * Extra lead length: specify length required.
- * Extended shell length, with sensitivity at the top or bottom: specify length required and sensitivity.

⚠ WARNING: Cancer and Reproductive Harm - www.P65Warnings.ca.gov.

Design Features

- * Flexible armor cable over leads: blockhead style B only. Specify length required.
- * Moisture resistant seal.
- * Moisture resistant or explosion resistant, N7, attached to a Type C coupling head thermostat; specify requirements.
- * Ground wire attached to the shell; specify length required.

SELECTION GUIDE

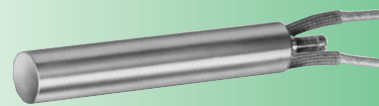

Type S Cartridge

Temperature controller for applications in metal, air, gas and many other mediums.



Type B Block Head

The block head style allows the thermostat to be mounted without the use of bushings. Also excellent for making right-angle connections.



Type P Pipe Thread

Designed for mounting in tanks for temperature control of liquids or gases. A stainless steel bushing affords ease of mounting and a positive seal.



Type C Coupling Head

Designed to accept conduit or plumbing fittings to protect the screw and lead wires in adverse conditions.

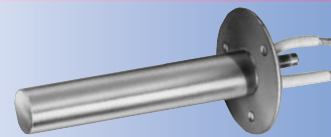

Type F Flange

Designed to mount directly to duct or oven wall for the sensing of air or gas temperatures.

All Items Available from Stock

Dimensional Specifications

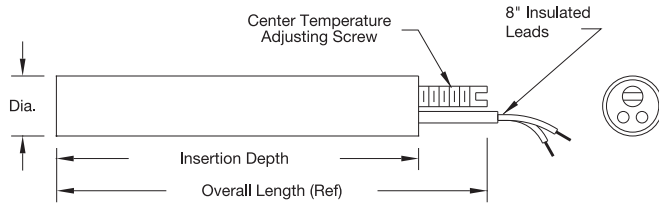

Type S — Cartridge Style

Diameter	Overall Length (Reference Only)	Insertion Depth
5/8"	4-3/8"	3-5/8"
1/2"	3-1/4"	2-1/2"
1/4"	1-5/8"	1-7/16"

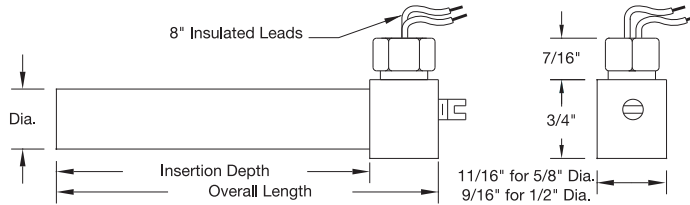

Type B — Block Head Style

Diameter	Overall Length	Insertion Depth	Block Thk.
5/8"	4-3/16"	3-7/16"	3/4"
1/2"	3-1/16"	2-5/16"	3/4"
1/4"	Not Available		

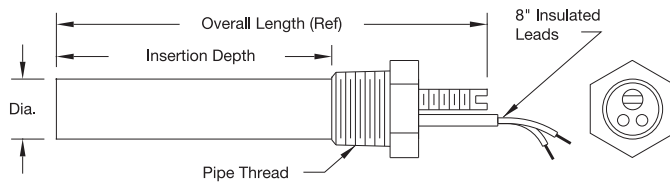

Type P — Pipe Thread

Diameter	Overall Length (Reference Only)	Insertion Depth	Pipe Thread
5/8"	4-3/8"	3"	1/2"-14 NPT
1/2"	3-1/4"	2"	3/8"-18 NPT
1/4"	1-5/8"	3/4"	1/8"-27 NPT

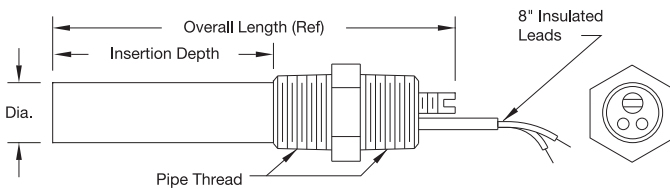

Type C — Coupling Head

Diameter	Overall Length (Reference Only)	Insertion Depth	Pipe Thread
5/8"	4-1/2"	3"	1/2"-14 NPT
1/2"	3-1/4"	2"	3/8"-18 NPT
1/4"	1-3/4"	3/4"	1/8"-27 NPT

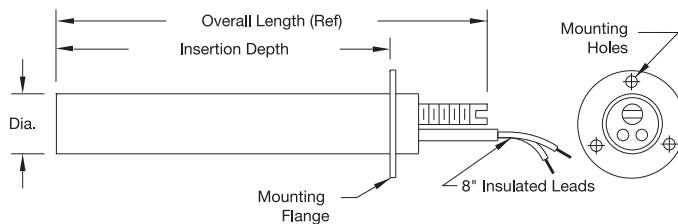

Type F — Flange

Diameter	Overall Length (Reference Only)	Insertion Depth	Flange Dia.	Mounting Holes (3)
5/8"	4-3/8"	3-5/16"	1-3/4"	.156" dia. on a 1.25" DBC
1/2"	3-1/4"	2-5/16"	1-1/2"	.156" dia. on a 1" DBC
1/4"	1-5/8"	1-1/4"	1"	.144" dia. on a 5/8" DBC

Installation Guidelines and Observations

- Do not expose the thermostat to more than 100°F / 38°C above the setpoint temperature.
- On 1/2" and 5/8" diameter thermostats, do not turn the adjusting screw more than 7 revolutions in either direction from room temperature.
- On 1/4" diameter thermostats, do not turn the screw more than 1/4 revolution in either direction from room temperature without checking temperature setpoint.
- Removal of the adjusting screw may render the thermostat inoperative.
- System vibration can cause contact bounce. The addition of a capacitor will reduce the bouncing and overshooting. The recommended capacitor is 0.1 μF rated at 600VDC for 120 VAC applications and 1000VDC for 240 VAC applications. The capacitor should be attached parallel across the thermostat's leads.
- Optimum performance will result when the amperage load is half of the maximum rating.
- Do not attempt to seal the lead end with silicone materials such as caulking or grease.

Solid State Relays

Single-Phase Solid State Relays (SSRs)

Tempco's Solid State Relays are a highly reliable alternative to mechanical or mercury contactors in high amperage or harsh environments. They offer years of trouble-free service and millions of cycles with no moving parts to wear out.

- * 1-phase normally open models – current ratings from 10 Amp through 75 Amp
- * Zero-cross outputs for general applications
- * UL/cUL Recognized, CE Compliant
- * Back-to-back SCR output stage
- * AC or DC control inputs
- * 240 or 480 Volt Outputs

- Select a **DC control** input relay to work with a temperature control having an **SSR drive output**.
- Choose an **AC control** input relay to work with a temperature control having a **mechanical relay output**.

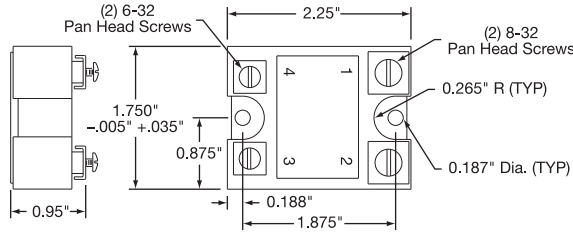

All Items Available from Stock

Standard Stock Single-Phase Relays

Nominal Output Voltage	240 VAC		480 VAC		Load Current
	DC	AC	DC	AC	
Control Input					
Part Number	RLS02110 RLS02125 RLS02145 RLS02175	RLS02210 RLS02225 RLS02245 RLS02275	RLS04110 RLS04125 RLS04150 RLS04175	RLS04210 RLS04225 RLS04250 RLS04275	10A 25A 50A 75A
Min. Control Input Current (mA)	7	5	7	5	
Max. Line Voltage (VAC, rms)	280	280	660	660	
Min. Line Voltage (VAC, rms)	24	24	48	48	
Max. Off-State Voltage (V _{peak})	±600	±600	±1200	±1200	
Max. Off-State Leakage (mA rms)	0.25		On-State Voltage Drop (V _{peak})		1.35
Static (Off-State) $\Delta v/\Delta t$ (V/ μ S)	500		Min. On-State Current (mA)		100
Operating Temp. Range (°C)	-20 to +80, (°F) -4 to +176		Line Frequency Range (Hz)		47 to 63

Notes:



1. DC control input = 3-32 VDC
2. AC control input = 90-280 VAC
3. Adequate heat sinking, including consideration of air temperature and flow, is essential to the proper operation of a solid state relay.

Ordering Information

Choose the **Part Number** of the relay from the table that matches the needs for your application. We also offer other styles of Solid State Relays, such as random turn on; consult Tempco with your requirements. **Standard lead time is stock to 3 weeks.**

Accessories

For solid state relays Tempco offers a snap-on cover made of high impact, flame retardant polycarbonate that will provide "finger-safe" operation.

Snap-on Cover

For 1-phase SSR: **RLS90001**

Thermal Compound: RLS90003

2-ounce container

Thermal Heat Transfer Pads:

For 1-Phase SSR: **RLS90004**

For 3-Phase SSR: **RLS90005**

De-Rating Curves for Single Phase Solid State Relays



Solid state relay de-rating curves are used to determine the actual current the relay is capable of carrying vs. the ambient temperature in the enclosure. It also indicates the heat sink required to

dissipate the heat the relay produces at the ambient temperature. Failure to dissipate the internally generated heat will result in solid state relay failure.

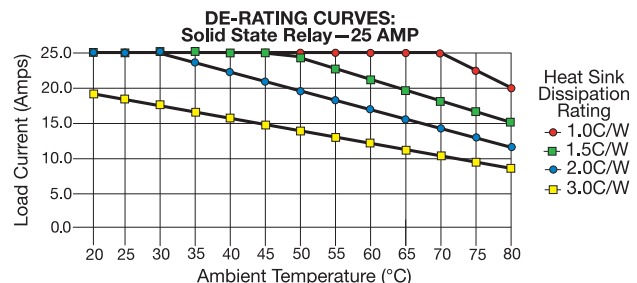
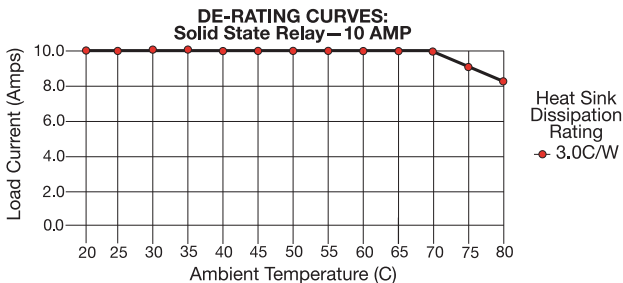

WARNING: Cancer and Reproductive Harm - www.P65Warnings.ca.gov.

CONTINUED

De-Rating Curves for Single-Phase Solid State Relays (continued)

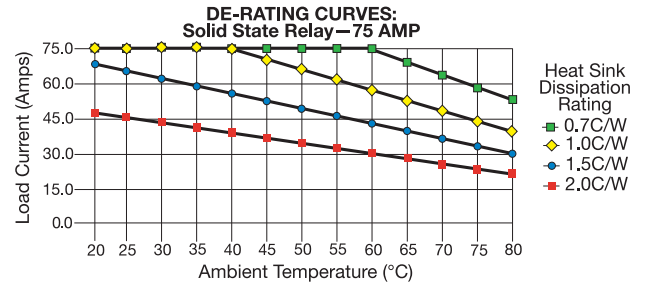
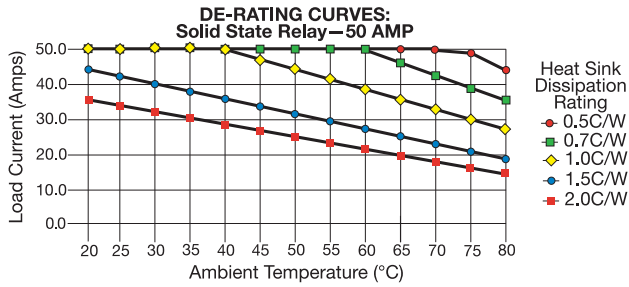

Standard Stock Heat Sinks for Solid State Relays



Part Number: RLS90017
Size: 1.77"W × 3.19"L × 3.15"H
Rating: 2.0°C/W
 Pre-drilled for 1-phase SSR (8-32)
 DIN rail or panel mount



Part Number: RLS90018
Size: 1.77"W × 3.19"L × 3.74"H
Rating: 1.5°C/W
 Pre-drilled for 1-phase SSR (8-32)
 DIN rail or panel mount

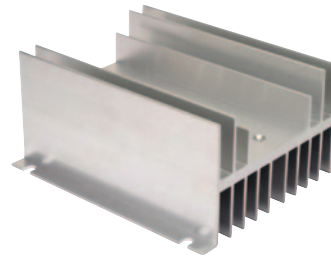

Part Number: RLS90019
Size: 4.75"W × 5.50"L × 2.63"H
Rating: 0.70°C/W
 Pre-drilled for one or two 1-phase SSR (8-32)
 Panel mount 4.50" × 4.42" centers



Part Number: RLS90020
Size: 3.00"W × 5.20"L × 2.37"H
Rating: 1.0°C/W
 Pre-drilled for one 3-phase SSR (8-32)
 DIN rail mount

Three-Phase Solid State Relays (SSRs)

Tempco's Three-phase Solid State Relays are a highly reliable alternative to mechanical or mercury contactors in high amperage or harsh environments. They offer years of trouble-free service and millions of cycles with no moving parts to wear out.

- * 3-phase normally open models—current ratings 25 Amp and 50 Amp
- * Zero-cross outputs for general applications
- * UL recognized, CSA certified and CE compliant
- * Back-to-back SCR output stages
- * AC or DC control inputs
- * Single output type for 48 through 530 VAC
- Select a **DC control** input relay to work with a temperature control having an **SSR drive output**.
- Choose an **AC control** input relay to work with a temperature control having a **mechanical relay output**.

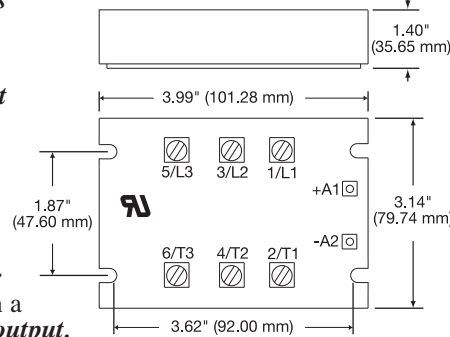

All Items Available from Stock



Standard Stock Three-Phase Relays

Nominal Output Voltage Control Input	48 through 530 VAC			Load Current
	4-32 VDC	90-140 VAC	180-260 VAC	
Part Number	RLS36125 RLS36150	RLS36226 RLS36250	RLS36227 RLS36251	25A 50A
Max. Line Voltage Range (VAC, rms)	48 through 530 VAC			
Max. Off-State Voltage (Vpeak)	±1100	±1100	±1100	
Min. Control Current (mA)	24	7	7	
Max. Off-State Leakage (mA rms)	0.06	On-State Voltage Drop (Vpeak) 1.35		
Static (Off-State) Δv/Δt (V/μS)	500	Min. On-State Current (mA) 100		
Operating Temp. Range (°C)	-20 to 80	Line Frequency Range (Hz) 47 to 63		
	(°F) -4 to 176			



Note: Adequate heat sinking, including consideration of air temperature and flow, is essential to the proper operation of a solid state relay.

CONTINUED ➔

De-Rating Curves for 3-Phase Solid State Relays



Solid state relay de-rating curves are used to determine the actual current the relay is capable of carrying vs. the ambient temperature in the enclosure. It also indicates the heat sink required to dissipate the heat the relay produces at the ambient temperature. Failure to dissipate the internally generated heat will result in solid state relay failure.

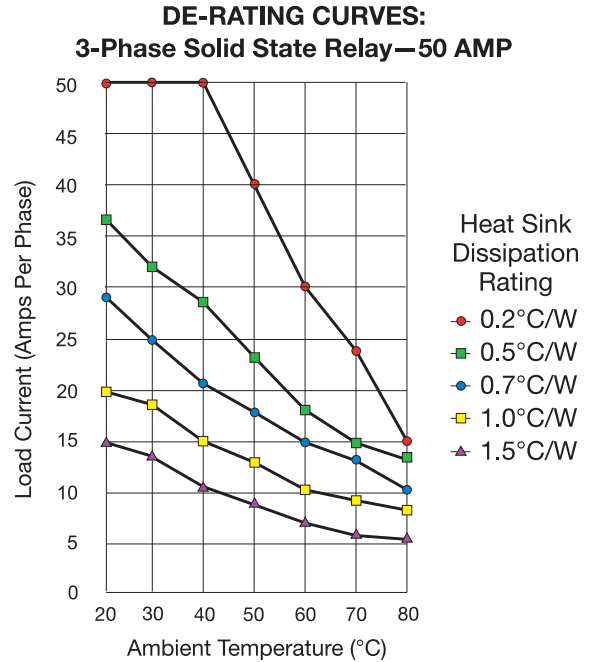
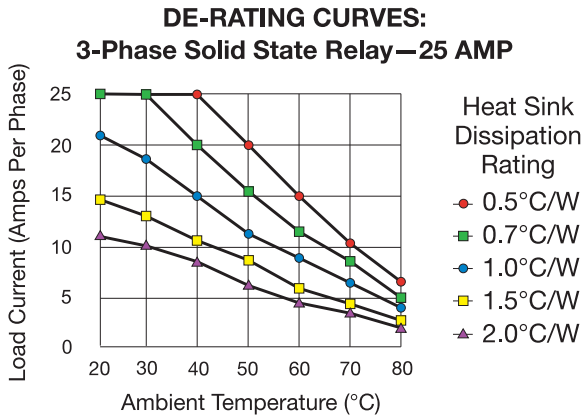

“Power Pack” DIN Rail Mount Solid State Relay Modules

The **Power Pack** combines in one easy-to-use compact package the traditional hockey puck style solid state relay and required heat sink. This combination eliminates having to mount the SSR to a separate heat sink. It also incorporates the finger-safe cover into the housing’s design. Each Power Pack takes up much less room than the standard SSR and heat sink combination.



Available from Stock

Design Features

- * Self-Contained Solid State Relay and Heat Sink
- * Standard 35mm DIN Rail or Panel Mount
- * 1-phase Units with Zero-Cross Firing Output
- * 3-Phase Units Control All 3 Phases
- * Current Ratings from 12 through 45 Amp
- * 3 Compact Sizes: 22.5mm, 45.0mm, and 90.0mm
- * Triac or Back-to-Back SCR Outputs
- * UL, cUL Recognized

Standard Stock DIN Rail Relays

Size	Output Current	Output Voltage	Control Input	Output Type	Max. Turn On Time	Max. Turn Off Time	Min. On State Cur.	Peak On Vol. drop	Part Number
One-Phase Models									
22.5 mm	10A	24-280 VAC	4-32 VDC	Triac	8.33 mS	8.33 mS	19 mA	1.5 Vpk	RLS80001
			90-140 VAC		20 mS	30 mS	23 mA		RLS80005
			180-280 VAC		20 mS	30 mS	23 mA		RLS80006
	20A	48-600 VAC	4-32 VDC	B/B SCR	8.33 mS	8.33 mS	19 mA	1.35 Vpk	RLS80003
			90-140 VAC		20 mS	30 mS	23 mA		RLS80007
			180-280 VAC		20 mS	30 mS	23 mA		RLS80008
30A	48-600 VAC	4-32 VDC	B/B SCR	8.33 mS	8.33 mS	19 mA	1.35 Vpk	RLS80009	
		90-140 VAC		20 mS	30 mS	23 mA		RLS80010	
		180-280 VAC		20 mS	30 mS	23 mA		RLS80011	
45.0 mm	35A	48-660 VAC	4-32 VDC	B/B SCR	8.33 mS	8.33 mS	19 mA	1.35 Vpk	RLS80101
			90-140 VAC		20 mS	30 mS	23 mA		RLS80103
			180-280 VAC		20 mS	30 mS	23 mA		RLS80104
	45A	48-660 VAC	4-32 VDC	B/B SCR	8.33 mS	8.33 mS	19 mA	1.35 Vpk	RLS80105
			90-140 VAC		20 mS	30 mS	23 mA		RLS80106
			180-280 VAC		20 mS	30 mS	23 mA		RLS80107
Three-Phase Models									
90.0 mm	25A	48-660 VAC	4-32 VDC 90-140 VAC 180-280 VAC	B/B SCR	8.33 mS 20 mS 20 mS	8.33 mS 30 mS 30 mS	19 mA 23 mA 23 mA	1.35 Vpk	RLS80201 RLS80203 RLS80204

Specifications and De-Rating Curves for Power Pack DIN Rail Relay Modules

Dimensional Specifications mm (inches)

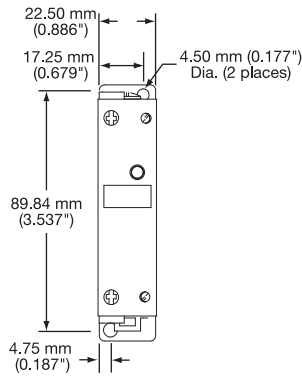

Depth 120.75 mm (4.754")

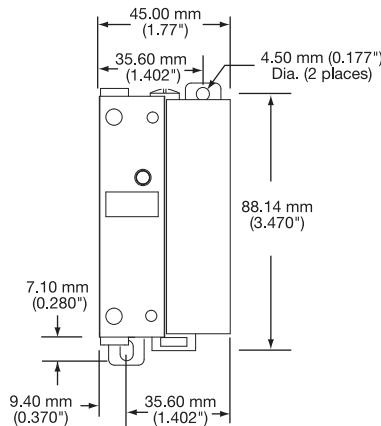

Depth
120.66 mm (4.750")

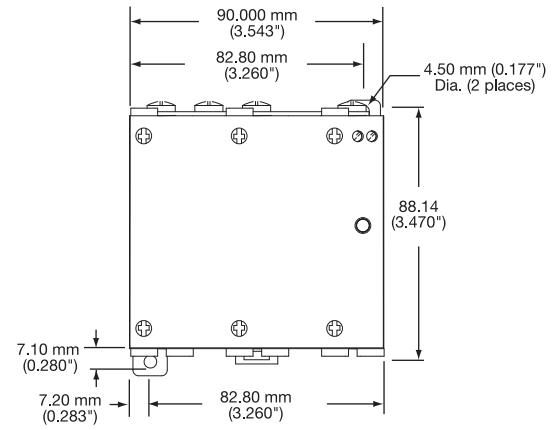

Depth
123.40 mm (4.858")

Derating Curve – 22.5 mm size

10 AMP Series De-rating Curves

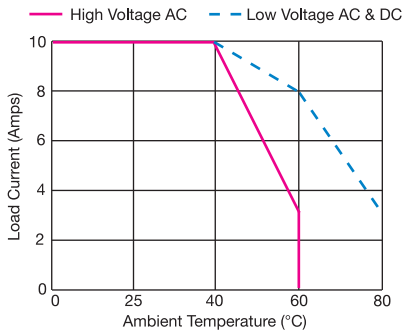

20 AMP Series De-rating Curves

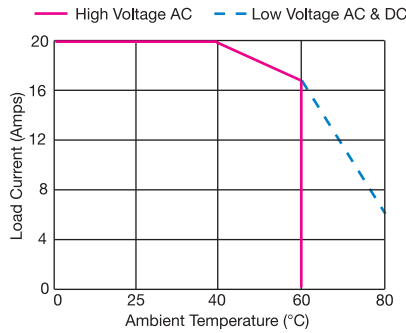

30 AMP Series De-rating Curves

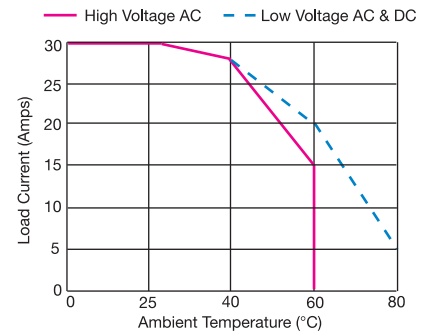

Derating Curve – 45 mm size

35 AMP Series De-rating Curves

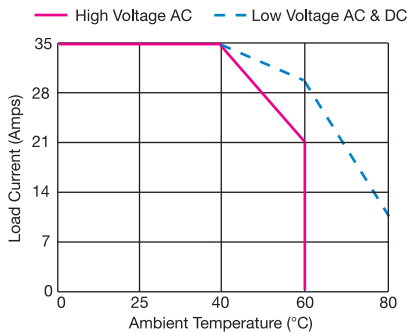

45 AMP Series De-rating Curves

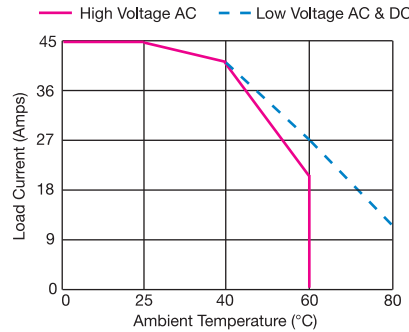

Derating Curve – 90 mm size

25 AMP-3 Phase Series De-rating Curves

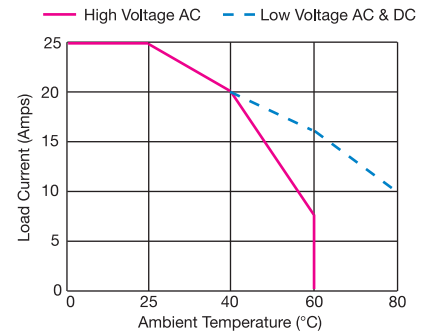

Ordering Information

Choose the **Part Number** of the relay from the table above that matches the needs for your application. Tempco also offers a complete line of SCR Power Controls, Mechanical Relays, and Mercury Relays for your power handling needs. **Standard lead time is stock to 3 weeks.**

⚠ WARNING: Cancer and Reproductive Harm - www.P65Warnings.ca.gov.

(800) 323-6859 • Email: sales@tempco.com

Mercury Relays

Mercury Displacement Relays — 35 & 60 Amp Resistive Loads

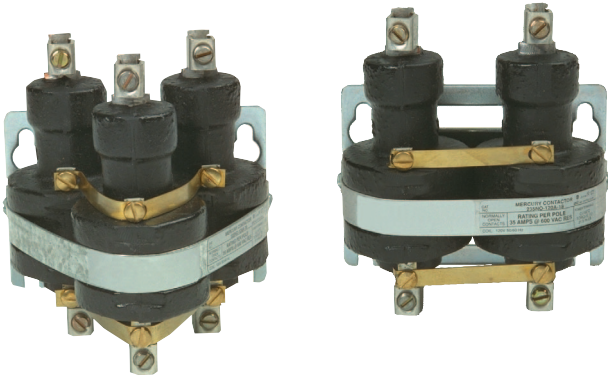

Tempco's Mercury Displacement Relays are specifically designed for resistive loads typical of heating and process equipment. These mercury relays are available in 35 and 60 amp models with single, double and triple pole configurations. Coil voltages range from 24 to 480 Volts AC at 50/60 Hz and 24 Volts DC.

Features

Mercury contact action relays are superior to open contact electro-mechanical relays. Mercury relays do not contain springs or button contacts, which tend to wear, weld and burn out. Mercury contacts are capable of rapid on-off cycling in excess of 6 times per minute under resistive loads. This provides more precise process temperature control, and eliminates the noise from the on-off operating cycles of electro-mechanical relays and contactors.

Typical Applications

- ➔ Industrial Process Equipment Utilizing Resistive Loads
- ➔ Industrial Ovens
- ➔ Duct Heaters
- ➔ Plastic Injection and Extrusion Machinery
- ➔ Food Processing Equipment

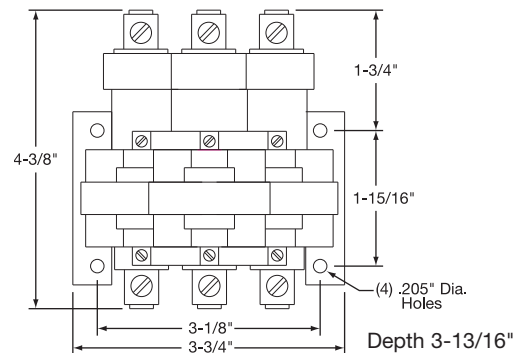
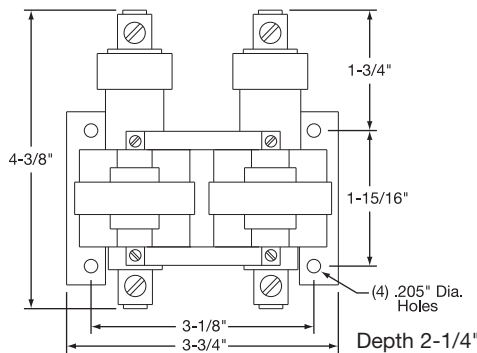
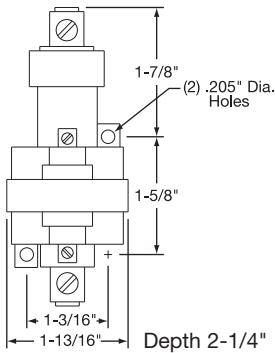

Standard (Non-Stock) and Stock Mercury Relay Specifications

Stock Items Are Shown In RED

Type	35 AMP RELAYS				Coil Resistance (ohms)	60 AMP RELAYS		
	Coil Volts	Coil Current	Cross Reference MDI	TEMPCO Part Number		Coil Current	Cross Reference MDI	TEMPCO Part Number
1 Pole Normally Open	24 VDC	136 mA	35NO-24D	RLY01355	176	136 mA	60NO-24D	RLY01605
	24 VAC	242 mA	35NO-24A	RLY01353	50	259 mA	60NO-24A	RLY01603
	120 VAC	53 mA	35NO-120A	RLY01351	1250	48 mA	60NO-120A	RLY01601
	220 VAC	28 mA	35NO-220A	RLY01352	4800	27 mA	60NO-220A	RLY01602
	277 VAC	20 mA	35NO-277A	RLY01356	7900	19 mA	60NO-277A	RLY01606
	480 VAC	12 mA	35NO-480A	RLY01354	20000	12 mA	60NO-480A	RLY01604
2 Poles Normally Open	24 VDC	272 mA	235NO-24D-18	RLY02355	88	272 mA	260NO-24D-18	RLY02605
	24 VAC	484 mA	235NO-24A-18	RLY02353	25	518 mA	260NO-24A-18	RLY02603
	120 VAC	106 mA	235NO-120A-18	RLY02351	625	96 mA	260NO-120A-18	RLY02601
	220 VAC	56 mA	235NO-220A-18	RLY02352	2400	54 mA	260NO-220A-18	RLY02602
	277 VAC	40 mA	235NO-277A-18	RLY02356	3950	38 mA	260NO-277A-18	RLY02606
	480 VAC	24 mA	235NO-480A-18	RLY02354	10000	24 mA	260NO-480A-18	RLY02604
3 Poles Normally Open	24 VDC	408 mA	335NO-24D-18	RLY03355	59	408 mA	360NO-24D-18	RLY03605
	24 VAC	726 mA	335NO-24A-18	RLY03353	17	777 mA	360NO-24A-18	RLY03603
	120 VAC	159 mA	335NO-120A-18	RLY03351	417	144 mA	360NO-120A-18	RLY03601
	220 VAC	84 mA	335NO-220A-18	RLY03352	1600	81 mA	360NO-220A-18	RLY03602
	277 VAC	60 mA	335NO-277A-18	RLY03356	2633	57 mA	360NO-277A-18	RLY03606
	480 VAC	36 mA	335NO-480A-18	RLY03354	6667	36 mA	360NO-480A-18	RLY03604

NOTE: The 220 VAC coil is used from 208 to 240 VAC.

Specifications

- Operate Time:** 50 mSec **Release Time:** 80 mSec
- Contact Rating:** 35 Amp – 600 VAC, 60 Amp – 480 VAC
- Contact Resistance:** 35 Amp – .003Ω, 60 Amp – .002Ω
- Temperature Range:** -31 to 185°F (-35 to 85°C)
- Dielectric Strength:** 2500 VAC RMS
- Agency Approvals:** UL, CSA

⚠ WARNING: Cancer and Reproductive Harm - www.P65Warnings.ca.gov.

Ordering Information

Choose the **Part Number** of the relay from the table above that matches the needs for your application. We also offer other styles of Mercury Relays—consult Tempco with your requirements.

Standard lead time is stock to 5 days.

Mercury Displacement Relays — 100 Amp Resistive Loads

DE-RATING CURVES:
100 AMP Normally Open

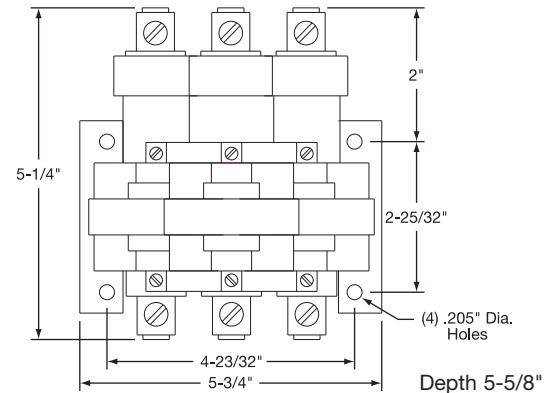
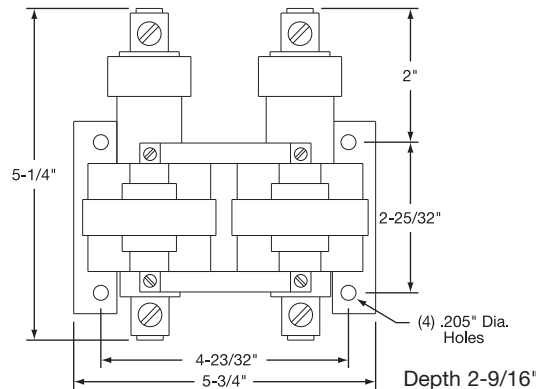
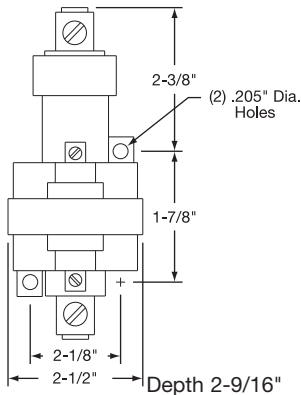
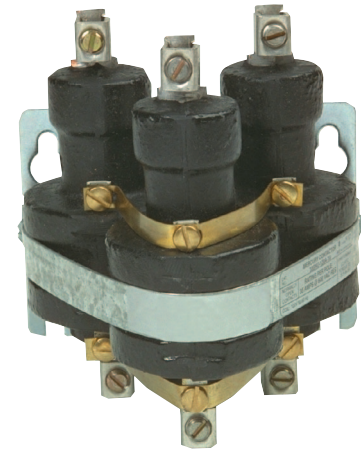
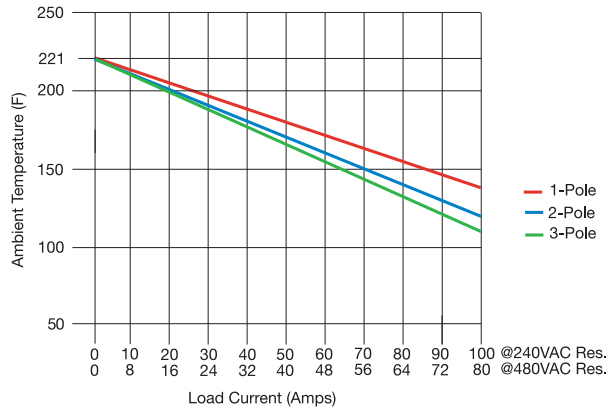

Specifications

- Operate Time:** 50 mSec
- Release Time:** 80 mSec
- Contact Rating:** 240 VAC – 100 Amp
480 VAC – 80 Amp
- Contact Resistance:** .001Ω
- Temperature Range:** -31 to 185°F
(-35 to 85°C)
- Dielectric Strength:** 2500 VAC RMS
- Agency Approvals:** UL, CSA

Standard (Non-Stock) and Stock Mercury Displacement Relay Specifications

Stock Items Are Shown In RED

Type	Coil Volts	100 AMP RELAYS		Coil Resistance (ohms)	TEMPCO Part Number
		Coil Current	Cross Reference MDI		
1 Pole Normally Open	24 VDC	369 mA	100NO-24D	65	RLY90030
	24 VAC	646 mA	100NO-24A	16	RLY90031
	120 VAC	137 mA	100NO-120A	380	RLY90032
	220 VAC	73 mA	100NO-220A	1400	RLY90033
	277 VAC	55 mA	100NO-277A	2400	RLY90034
	480 VAC	35 mA	100NO-480A	6300	RLY90035
2 Poles Normally Open	24 VDC	738 mA	2100NO-24D-18	33	RLY90036
	24 VAC	1292 mA	2100NO-24A-18	8	RLY90037
	120 VAC	274 mA	2100NO-120A-18	190	RLY90023
	220 VAC	146 mA	2100NO-220A-18	700	RLY90038
	277 VAC	110 mA	2100NO-277A-18	1200	RLY90039
	480 VAC	70 mA	2100NO-480A-18	3150	RLY90040
3 Poles Normally Open	24 VDC	1107 mA	3100NO-24D-18	22	RLY90041
	24 VAC	1938 mA	3100NO-24A-18	5.3	RLY90042
	120 VAC	411 mA	3100NO-120A-18	127	RLY90019
	220 VAC	219 mA	3100NO-220A-18	467	RLY90013
	277 VAC	165 mA	3100NO-277A-18	800	RLY90043
	480 VAC	105 mA	3100NO-480A-18	2100	RLY90044

Ordering Information

Choose the **Part Number** of the relay from the table above that matches the needs for your application. We also offer other styles of Mercury Relays—consult Tempco with your requirements.

Standard lead time is stock to 5 days.

⚠ WARNING: Cancer and Reproductive Harm - www.P65Warnings.ca.gov.

High Performance Economical Mercury Relays — 30 Amp Resistive Loads

The 30 Amp model is designed to save space and simplify mounting methods. It is also extremely economical due to the use of a single coil for 1-, 2- or 3-pole relays. The universal mounting bracket used on the 2- and 3-pole relays has various mounting holes and keyhole slots to meet a variety of mounting centers.

The 30 Amp Series is a more compact line with a well-proven switch, which is the heart of mercury relays. It is the same switch design that drives our 35 and 60 Amp encapsulated **Mercury Displacement Relays**, which have withstood the test of time and millions of cycles in many different applications.

Standard (Non-Stock) and Stock High Performance Mercury Displacement Relay Specifications

Stock Items Are Shown In **RED**

Type	30 AMP RELAYS			Cross Reference MDI	TEMPCO Part Number
	Coil Volts	Coil Current	Coil Resist. (ohms)		
1 Pole N.O.	24 VDC	113 mA	213	30NO-24DU	RLY11305
	24 VAC	216 mA	55	30NO-24AU	RLY11303
	120 VAC	65 mA	725	30NO-120AU	RLY11301
	220 VAC	28 mA	3380	30NO-220AU	RLY11302
2 Poles N.O.	24 VDC	260 mA	92	230NO-24DU	RLY12305
	24 VAC	580 mA	15	230NO-24AU	RLY12303
	120 VAC	115 mA	367	230NO-120AU	RLY12301
	220 VAC	53 mA	1550	230NO-220AU	RLY12302
3 Poles N.O.	24 VDC	217 mA	110	330NO-24DU	RLY13305
	24 VAC	815 mA	7.6	330NO-24AU	RLY13303
	120 VAC	140 mA	215	330NO-120AU	RLY13301
	220 VAC	66 mA	766	330NO-220AU	RLY13302



Note: The 220 VAC coil is used from 208 to 240 VAC.

Ordering Information

Choose the **Part Number** of the relay from the table above that matches the needs for your application.

Standard lead time is stock to 5 days.

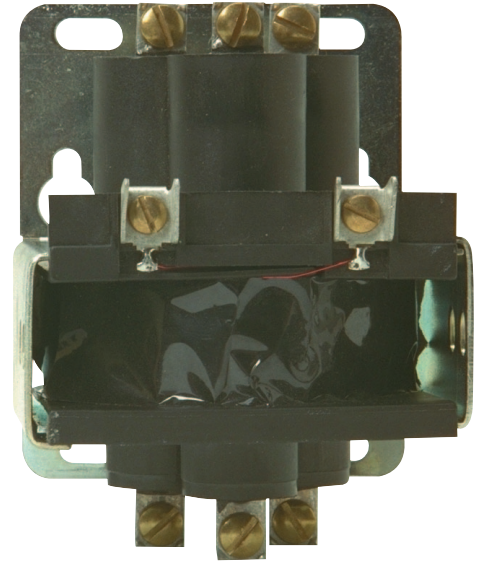

Specifications

Pull In Voltage: 90% of nominal (Min. AC)

Operate (pull in) Time: 50 mSec

Release Time: 80 mSec

Operating Ambient

Temperature Range: -35 to 85°C
(-31 to 185°F)

Typical Contact Resistance: 3 mΩ

Contact Rating: 30 Amps

Dielectric Breakdown: 2500 VAC RMS

Mount: Vertical ±10°

Coil terminals: #6 binding head screws

Load terminals: #8 binding head screws

Agency Approvals: UL, CSA

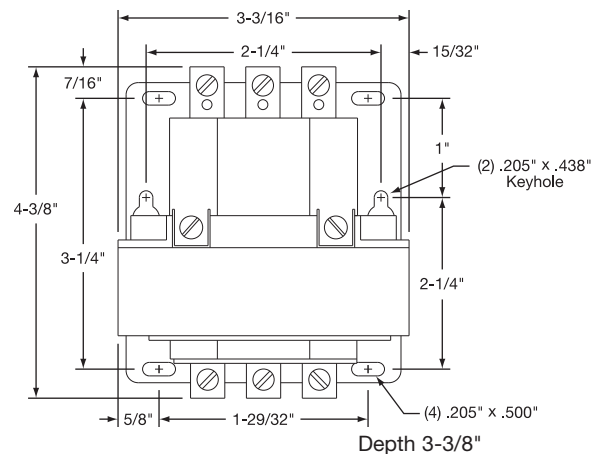
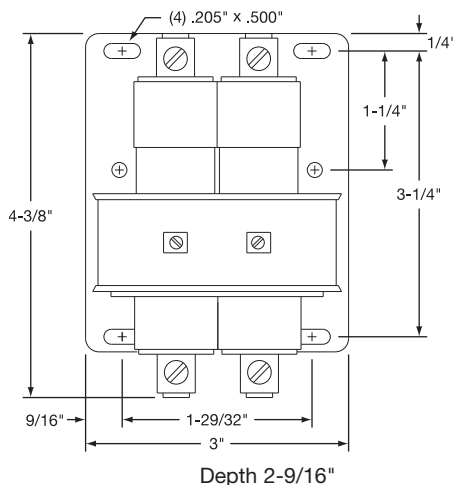
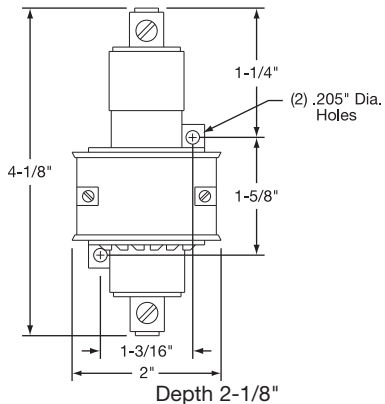

WARNING: Cancer and Reproductive Harm - www.P65Warnings.ca.gov.

DIN Rail Mounted Mechanical Relays

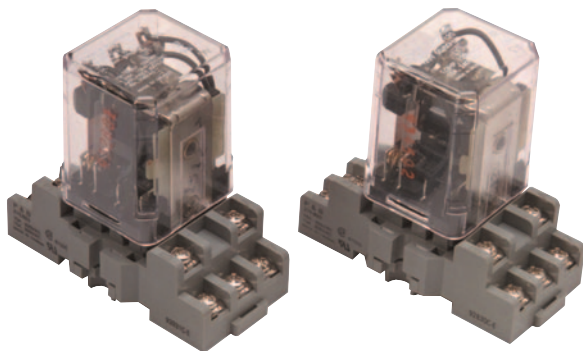

Design Features

- * 10 and 15 Amp Models with 24 VDC, 120 and 240 VAC Coils
- * Sockets Mount on Standard 35 mm DIN Track
- * Silver-Cadmium Oxide Contacts
- * Socket and Relay Separation Fast and Easy
- * UL and CSA Component Recognition
- * Compact for Easy DIN Rail Installation
- * Contact Arrangement Up to 3PDT
- * Enclosed to Prevent Contamination

Standard DIN Rail Mount Relay Specifications

Common Usage @ 240VAC	Coil Voltage	Poles	Potter & Brumfield Cross Reference Number	TEMPCO Part Number
10A	24 VDC	1	KUP-5D15-24	RLM01103
10A	120 VAC	1	KUP-5A15-120	RLM01101
10A	240 VAC	1	KUP-5A15-240	RLM01102
10A	24 VDC	2	KUP-11D15-24	RLM02103
10A	120 VAC	2	KUP-11A15-120	RLM02101
10A	240 VAC	2	KUP-11A15-240	RLM02102
10A	24 VDC	3	KUP-14D15-24	RLM03103
10A	120 VAC	3	KUP-14A15-120	RLM03101
10A	240 VAC	3	KUP-14A15-240	RLM03102
15A	24 VDC	2	KUMP-11D18-24	RLM02153
15A	120 VAC	2	KUMP-11A18-120	RLM02151
15A	240 VAC	2	KUMP-11A18-240	RLM02152
15A	24 VDC	3	KUMP-14D18-24	RLM03153
15A	120 VAC	3	KUMP-14A18-120	RLM03151

Electrical Contact Ratings

Type	UL/CSA Ratings	Exp. Life
1-2 Pole KUP	10 Amps @ 28 VDC or 240 VAC, 80% PF 5 Amp tungsten @ 120 VAC, 3A 600 VAC, 1/2 Amp @ 120 VDC	100,000 cycles
KUMP	1/3 HP @ 120 VAC, 1/2 HP @ 240, 480, and 600 VAC, 10 FLA 30 LRA @ 120 VAC, 5 FLA, 15 LRA @ 250 VAC (FLA ratings covered by 30,000 operations)	
KUMP	15 Amp @ 277 VAC, 80% PF KUM KUMP	100,000 cycles
3-Pole KUP	10 Amp @ 28 VDC or 120 VAC, 80% PF, 6-2/3 Amp @ 240 VAC, 80% PF	100,000 cycles

DIN Rail Mounted Mechanical Relay Accessories

Universal Rail Mounted Socket



Universal socket for mounting 1- to 3-pole relays to a 35mm DIN rail track or surface mounted directly to a panel. A spring-loaded latch allows for easy installation or removal from a DIN mounting track. High strength, durable plastic body with 3/16" quick connect/solder; silver-cadmium oxide terminals for relay mounting.

Dimensions with Relay (approximate): 3" x 1-1/2" x 3"

Part Number: RLM90001

Part Number: RLM90004 — Relay Hold Down Spring



Universal 35 mm DIN Rail Track



Made out of extruded aluminum with holes on 6" centers. Holes accept #8 screws and the rail accepts the offered socket as a simple clip-on mount.

Dimensions: 36" (914mm) long

Part Number: EHD-134-102

Ordering Information

Choose the **Part Number** of the Relays and accessories that best fit the needs of your application.

Standard lead time is stock to 5 days.

WARNING: Cancer and Reproductive Harm - www.P65Warnings.ca.gov.

(800) 323-6859 • Email: sales@tempco.com

IEC Style Enclosed Contactors - 3 pole, 25A to 100A

Design Features

- * Regular and alternate coil termination locations
- * Contactors supplied with auxillary contacts as standard
- * Mounting - DIN rail or back panel
- * Coil Voltage Limits: Pick up - 85% to 110%
Drop-out - 30% to 60%
- * Operating Time: Closing - 12 to 22 mSec
Opening - 4 to 19 mSec
- * Contactors listed have screw clamp wiring terminals
- * Approvals: UL, cUL, CE
- * Auxiliary Switch Rating: 120VAC/6A, 240VAC/3A



3-Pole, 25 & 40 Amp

Maximum Voltage: 690VAC

2.89 x 1.77 x 3.39" / 73.5 x 45 x 86 mm (H x W x D)



3-Pole, 70 & 100 Amp

Maximum Voltage: 690VAC

4.17 x 3.11 x 4.80" / 106 x 79 x 122 mm (H x W x D)

MOUNTING DIMENSIONS

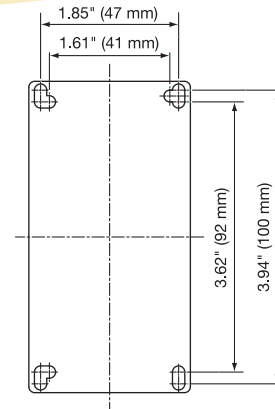
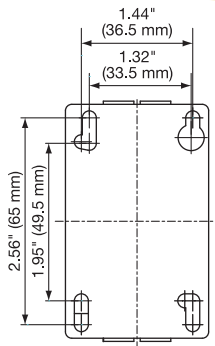

Standard (Non-Stock) and Stock Contactors

Stock Items Are Shown In **RED**

Resistive Amperage	Coil Voltage	Auxiliary Contacts	Carlo Gavassi Part Number	TEMPCO Part Number
25	24 VAC	1-NO, 1-NC	CC12SA24	RLM30001
25	120 VAC	1-NO, 1-NC	CC12SA120	RLM30002
25	220 VAC	1-NO, 1-NC	CC12SA220	RLM30003
40	24 VAC	1-NO, 1-NC	CC22SA24	RLM30004
40	120 VAC	1-NO, 1-NC	CC22SA120	RLM30005
40	220 VAC	1-NO, 1-NC	CC22SA220	RLM30006
70	24 VAC	2-NO, 2-NC	CC50SA24	RLM30007
70	120 VAC	2-NO, 2-NC	CC50SA120	RLM30008
70	220 VAC	2-NO, 2-NC	CC50SA220	RLM30009
100	24 VAC	2-NO, 2-NC	CC65SA24	RLM30010
100	120 VAC	2-NO, 2-NC	CC65SA120	RLM30011
100	220 VAC	2-NO, 2-NC	CC65SA220	RLM30012

Ordering Information

Order by **Part Number**.
Standard lead time is stock to 2 weeks.

⚠ WARNING: Cancer and Reproductive Harm - www.P65Warnings.ca.gov.

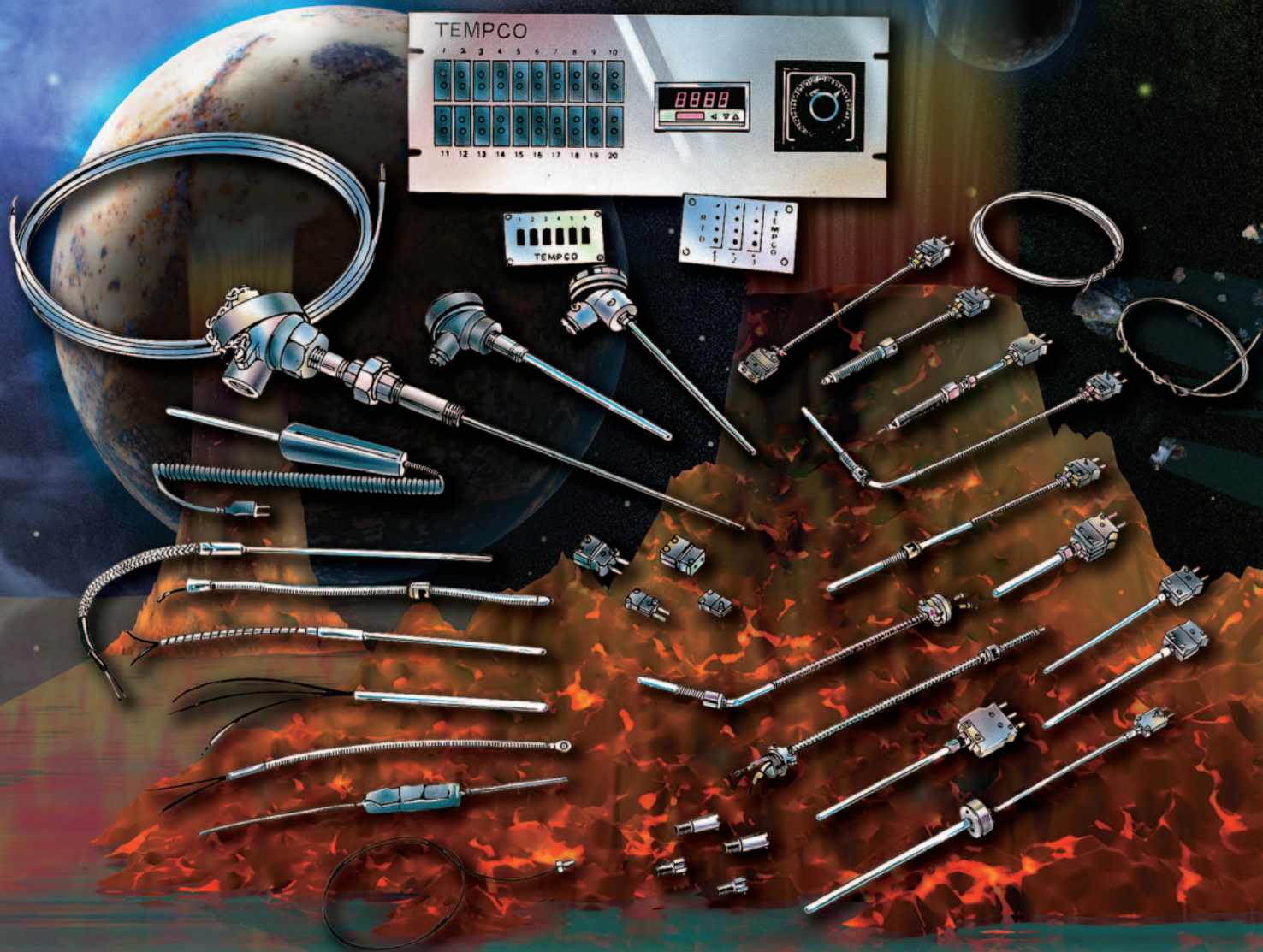

Table Of Contents

Pictorial Index	A-38	Thermowells.....	14-76
Plastics Industry Thermocouples.....	14-2	Ceramic Protection Tubes	14-85
Mineral Insulated Thermocouples.....	14-12	Metal Protection Tubes.....	14-86
Multipoint Thermocouples.....	14-28	Bayonet Adapters	14-87
Industrial Process Thermocouples	14-32	Protection Tube Hardware.....	14-88
Base Metal Thermocouples	14-37	Compression Fittings, Hex Nipples	14-89
Noble Metal Thermocouples	14-39	Plugs, Jacks & Hardware.....	14-90
OEM Replacement T/Cs	14-40	Thermocouple Insulators	14-96
Accu-Ohm RTDs	14-47	Open Disc Terminal Blocks	14-97
Sanitary RTDs.....	14-60	Connector Heads & Terminal Blocks	14-98
Plastics Industry RTDs.....	14-61	Plastic Melt Bolts (Blank).....	14-101
Plastics Industry Melt Bolt RTDs	14-65	Insulated Thermocouple, RTD and	
General Purpose NTC Thermistors.....	14-66	Extension Wire	14-102
Special Application Sensors	14-67	Mineral Insulated T/C Cable	14-114
Jack Panels.....	14-69	Glossary	14-125
Selector Switches & Panel Jacks	14-73		

Temperature Sensing

14
section

Tube and Wire Thermocouples

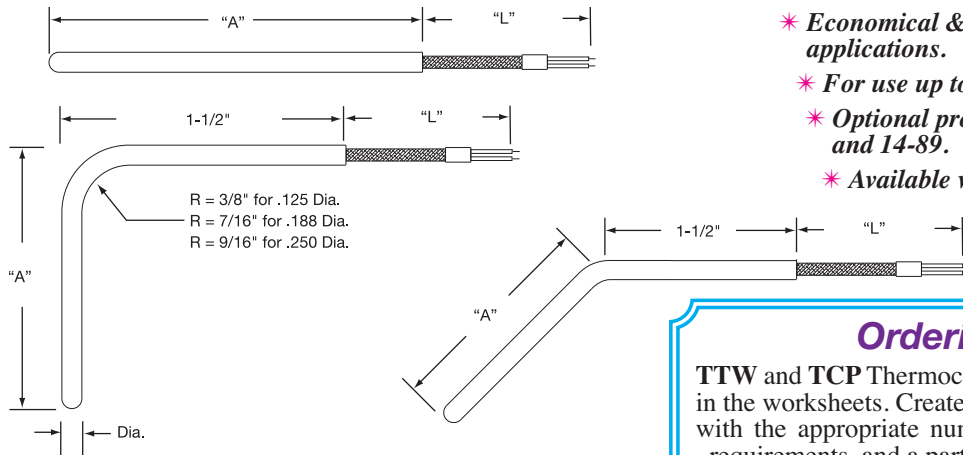

Design Features

- * Economical & versatile for a variety of applications.
- * For use up to 900°F (482°C).
- * Optional process fittings available. See pages 14-88 and 14-89.
- * Available with single or dual element.

Ordering Information

TTW and TCP Thermocouples are offered with the options listed in the worksheets. Create an ordering code by filling in the boxes with the appropriate number and/or letter designation for your requirements, and a part number will be assigned.

Ordering Code:

TTW -
 1
2
3
4
5
6
7
8
9
10
11

Style BOX 1

- 1 = Straight
- 2 = 45° Bend
- 3 = 90° Bend
- X = Other (Specify)

Calibration Code BOX 2

ANSI Standard Tolerances **J K E T N**

Junction BOX 7

	Grounded	Ungrounded
Single Element	G	U
Dual Element	4	5

Sheath Material BOX 3

- B = 304 SS
- C = 316 SS

Lead Wire Length "L" BOX 8

In inches **000** to **999**
Example 048 for 48"

Sheath O.D. BOX 4

- F = .125" ±.002
- G = .188" ±.002
- H = .250" ±.002
- X = Other (Specify)

Lead Wire Construction BOX 9

		w/ SS Overbraid	w/ SS Armor Cable
Fiberglass 900°F (482°C)	S	B	A
Teflon® 400°F (204°C)	T	D	F

Depending on availability, sheath OD of .125" uses 24 gauge lead wire. Larger than .125" thermocouples use 20 gauge lead wire depending on availability and insulation type.

Sheath Length "A" BOX 5

Whole inches
00 to **99**
For lengths over 99 in. consult TEMPCO.

Sheath Length "A" BOX 6

Fractional inches
0 = 0" **3** = 3/8" **6** = 3/4"
1 = 1/8" **4** = 1/2" **7** = 7/8"
2 = 1/4" **5** = 5/8"

Lead Wire Termination BOX 10 †

- | | |
|---|--|
| B = 2-1/2 in. Split Leads | J = Standard Female Jack |
| S = 2-1/2 in. Split Leads with Spade Lugs | K = Std. Plug with Mating Jack |
| C = 2-1/2 in. Split Leads with BX connector and Spade Lugs | D = Miniature Male Plug |
| P = Standard Male Plug | E = Miniature Female Jack |
| | F = Miniature Plug with Mating Jack |
| | X = Other (Specify) |

Special Requirements BOX 11

- X = Specify
- 0 = None

† See page 14-9 for Termination Style descriptions



Note: Metric sizes available. Consult TEMPCO

WARNING: Cancer and Reproductive Harm - www.P65Warnings.ca.gov.

Stock Bayonet Style Thermocouples — Type J

Design Features

- * **Standard—ANSI Type J Grounded Junction**
- * **Standard Probe Material—304 Stainless Steel**
- * **Standard Probe Diameter 3/16" (1/8" optional)**
- * **For use up to 900°F (482°C)**

Style 1—Spring Adjustable Bayonet Thermocouple

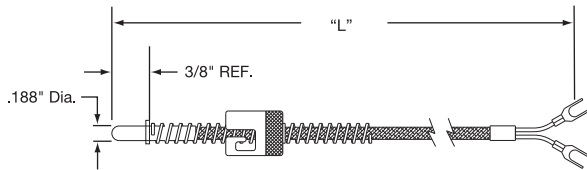

Design Features

- * **Insertion length adjustable from 1" to 10".**
- * **Forms easily to any angle.**
- * **One style can replace several fixed length thermocouples.**
- * **Use with bayonet adapters on page 14-87.**

All Items Available from Stock

Termination	36"	48"	60"	Part Number 72"	96"	120"	144"
Spade Lugs	TCP10131	TCP10001	TCP10140	TCP10079	TCP10086	TCP10095	TCP10096
Std. Plug	TCP10153	TCP10003	TCP10145	TCP10060	TCP10071	TCP10058	TCP10108
2½" Split Leads	TCP10156	TCP10005	TCP10141	TCP10012	TCP10011	TCP10020	TCP10059

Style 2—Armor Cable Adjustable Bayonet Thermocouple

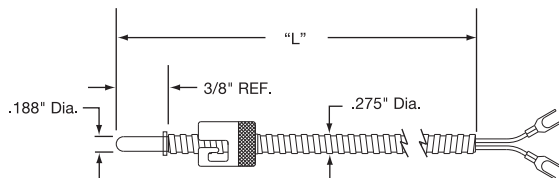

Design Features

- * **Insertion length adjustable over length of armor cable.**
- * **Forms easily to any angle.**
- * **One style can replace several fixed length thermocouples.**
- * **Use with bayonet adapters on page 14-87.**

All Items Available from Stock

Termination	36"	48"	60"	Part Number 72"	96"	120"	144"
Spade Lugs	TCP20084	TCP20001	TCP20041	TCP20040	TCP20031	TCP20053	TCP20085
Std. Plug	TCP20086	TCP20003	TCP20011	TCP20006	TCP20008	TCP20018	TCP20010
2½" Split Leads	TCP20025	TCP20005	TCP20050	TCP20026	TCP20060	TCP20007	TCP20093

Custom Made TCP Thermocouples (Adjustable Bayonet Style)

Ordering Code: TCP - 1 2 3 4 5 6 7 8

Style BOX 1

- 1 = Spring Adjustable
- 2 = Armor Cable Adjustable

Lead Insulation BOX 5

	w/ SS Overbraid (Style 1 only)	w/ SS Armor Cable (Style 2 only)
Fiberglass 900°F (482°C)	S	B
Teflon® 400°F (204°C)	T	D

Calibration BOX 2

ANSI Standard Tolerances **J K E T N**

Termination BOX 6 †

- | | |
|--|---|
| <ul style="list-style-type: none"> B = 2-1/2 in. Split Leads S = Spade Lugs C = Spade Lugs with BX Conn. P = Standard Plug J = Standard Jack | <ul style="list-style-type: none"> K = Standard Plug and Jack D = Miniature Plug E = Miniature Jack F = Mini. Plug and Jack X = Other (Specify) |
|--|---|

† See page 14-9 for Termination Style descriptions

Junction BOX 3

	Grounded	Ungrounded
Single Element	G	U
Dual Element	4	5

"L" Dimension BOX 4

Whole inches
012 to 999

Tip Style BOX 7

- R** = Round
- F** = Flat
- D** = Drill Point

Special Requirements BOX 8

- A** = .125 dia. Tip
- X** = Other (Specify)
- 0** = None

⚠ WARNING: Cancer and Reproductive Harm - www.P65Warnings.ca.gov.

Bayonet Styles

Style 3—Rigid Straight Bayonet Thermocouple

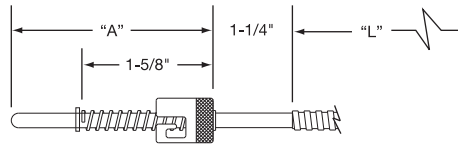

Stock Items Are Shown In **RED**

Part Number	Termination Style [†]	"A" Dim. (in)	"L" Dim. (in)
TCP30001	S	4	48
TCP30002	C	4	48
TCP30003	P	4	48
TCP30004	J	4	48
TCP30005	B	4	48

Design Features

- * Standard—ANSI Type J Grounded Junction
- * Standard Probe Material—304 Stainless Steel
- * Standard Probe Diameter—3/16" (1/8" optional)
- * For use up to 900°F (482°C)
- * See Page 14-87 for bayonet adapters and installation

Style 4—Rigid 45° Bend Bayonet Thermocouple

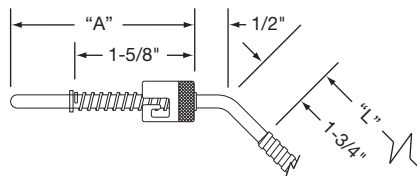

Part Number	Termination Style [†]	"A" Dim. (in)	"L" Dim. (in)
TCP40001	S	4	48
TCP40002	C	4	48
TCP40003	P	4	48
TCP40004	J	4	48
TCP40005	B	4	48

Style 5—Rigid 90° Bend Bayonet Thermocouple

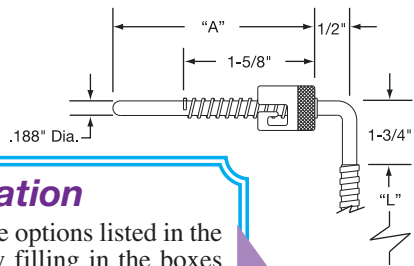

Part Number	Termination Style [†]	"A" Dim. (in)	"L" Dim. (in)
TCP50001	S	4	48
TCP50002	C	4	48
TCP50003	P	4	48
TCP50004	J	4	48
TCP50005	B	4	48

Ordering Information

TCP Thermocouples are offered with the options listed in the worksheets. Create an ordering code by filling in the boxes with the appropriate number and/or letter designation for your requirements, and a part number will be assigned.

[†] See page 14-9 for Termination Style descriptions

Ordering Code:

TCP -

Custom Made TCP Thermocouples (Bayonet Style)

Style BOX 1

- 3 = Straight
- 4 = 45° Bend
- 5 = 90° Bend

Calibration BOX 2

ANSI Standard Tolerances **J K E T N**

Junction BOX 6

Single Element Grounded **G** Ungrounded **U**
Dual Element **4** **5**

"L" Dimension BOX 7

Whole inches
000 to 999

Sheath Diameter BOX 3

- F = .125" ±.002
- G = .188" ±.002 (Standard)

Lead Insulation BOX 8

Fiberglass 900°F (482°C) **S** w/ SS Overbraided **B** w/ SS Armor Cable
Teflon® 400°F (204°C) **T** **D** **A** **F**

"A" Dimension BOX 4

Whole inches
01 to 99 (1-3/4" min.)

Termination BOX 9

(See page 14-9 for Termination Style Descriptions)
B = 2-1/2 in. Split Leads **P** = Standard Plug **D** = Miniature Plug
S = Spade Lugs **J** = Standard Jack **E** = Miniature Jack
C = Spade Lugs with BX Conn. **K** = Standard Plug and Jack **F** = Mini. Plug and Jack
X = Other (Specify)

"A" Dimension BOX 5

Fractional inches
0 = 0" **3** = 3/8" **6** = 3/4"
1 = 1/8" **4** = 1/2" **7** = 7/8"
2 = 1/4" **5** = 5/8"

Tip Style BOX 10

R = Round **F** = Flat **D** = Drill Point

Special Requirements BOX 11

X = Specify
0 = None

⚠ WARNING: Cancer and Reproductive Harm - www.P65Warnings.ca.gov.

Compression Fitting Styles

Style 6—Rigid Straight Compression Fitting Thermocouple

Part Number	Termination Style†	"A" Dim. (in)	"L" Dim. (in)
TCP60001	S	4	48
TCP60002	C	4	48
TCP60003	P	4	48
TCP60004	J	4	48
TCP60005	B	4	48

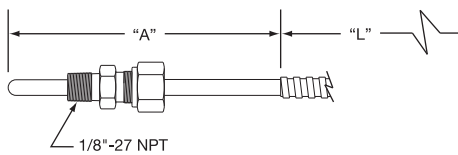

Design Features

- * Standard Calibration — ANSI Type J Grounded Junction
- * Standard Probe Material 304 Stainless Steel
- * Standard Probe Diameter—3/16"
- * For use up to 900°F (482°C)
- * One-Time Adjustable 1/8"-27 NPT Brass Compression Fitting

Style 7—Rigid 45° Bend Compression Fitting Thermocouple

Part Number	Termination Style†	"A" Dim. (in)	"L" Dim. (in)
TCP70001	S	4	48
TCP70002	C	4	48
TCP70003	P	4	48
TCP70004	J	4	48
TCP70005	B	4	48

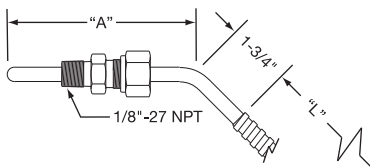

All Items Available from Stock

Style 8—Rigid 90° Bend Compression Fitting Thermocouple

Part Number	Termination Style†	"A" Dim. (in)	"L" Dim. (in)
TCP80001	S	4	48
TCP80002	C	4	48
TCP80003	P	4	48
TCP80004	J	4	48
TCP80005	B	4	48

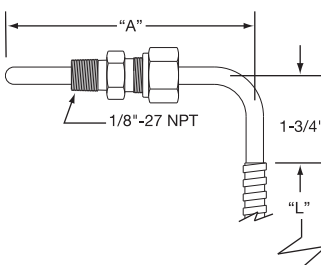

† See Page 14-9 for Termination Style descriptions.

Custom Made TCP Thermocouples (Compression Fitting Style)

Ordering Code:

TCP -

Style BOX 1

6 = Straight
7 = 45° Bend
8 = 90° Bend

Calibration BOX 2

ANSI Standard Tolerances J K E T N

Junction BOX 6

Single Element Dual Element
Grounded Ungrounded
G U
4 5

"L" Dimension BOX 7

Whole inches
000 to 999

Sheath Diameter BOX 3

F = .125
G = .188 (Standard)
H = .250
X = Other (Specify)

Lead Insulation BOX 8

Fiberglass 900°F (482°C) S B A
Teflon® 400°F (204°C) T D F

w/ SS Overbraid w/ SS Armor Cable

"A" Dimension BOX 4

Whole inches
01 to 99 (1-3/4" min.)

Termination BOX 9

(See page 14-9 for Termination Style Descriptions)
B = 2-1/2 in. Split Leads P = Standard Plug
S = Spade Lugs J = Standard Jack
C = Spade Lugs with BX Conn. K = Standard Plug and Jack
D = Miniature Plug
E = Miniature Jack
F = Mini. Plug and Jack
X = Other (Specify)

"A" Dimension BOX 5

Fractional inches
0 = 0" 3 = 3/8" 6 = 3/4"
1 = 1/8" 4 = 1/2" 7 = 7/8"
2 = 1/4" 5 = 5/8"

Tip Style BOX 10

R = Round F = Flat D = Drill Point

Special Requirements BOX 11

X = Specify
0 = None

WARNING: Cancer and Reproductive Harm - www.P65Warnings.ca.gov.

(800) 323-6859 • Email: sales@tempco.com

Surface Thermocouples

Ring Lug Thermocouples

* Ring thermocouples mount on a surface using an existing screw or bolt to measure surface temperature. The T/C wire junction is crimped to the ring lug.

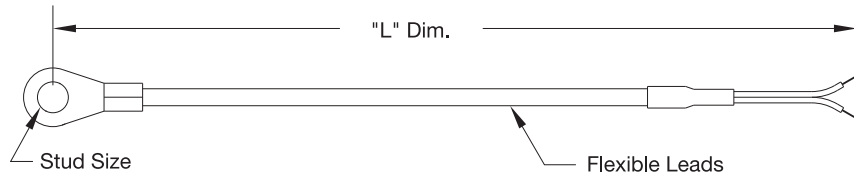

Ordering Code: **TRW** -

Stud Size BOX 1

- 1 = No. 6 (0.148)
- 2 = No. 8 (0.175)
- 3 = No. 10 (0.198)
- 4 = 1/4 (0.266)
- 5 = 3/8 (0.390)

Calibration BOX 2

ANSI Standard Tolerances **J K E T**

"L" Dimension BOX 3

Whole inches
Example: Enter **048** for 48 inches

Lead Insulation BOX 4

Fiberglass 900°F (482°C) **S** w/ SS Overbraid
Teflon® 400°F (204°C) **T** **B**
D

Termination BOX 5 †

B = 2-1/2 in. Split Leads **P** = Standard Plug **D** = Miniature Plug
S = Spade Lugs **J** = Standard Jack **E** = Miniature Jack
C = Spade Lugs with BX Conn. **K** = Standard Plug and Jack **F** = Mini. Plug and Jack
X = Other (Specify)

Special Requirements BOX 6

X = Specify
0 = None

† See page 14-9 for Termination Style descriptions

Shim Stock Thermocouples

* A low-profile sensor that can be placed between two surfaces

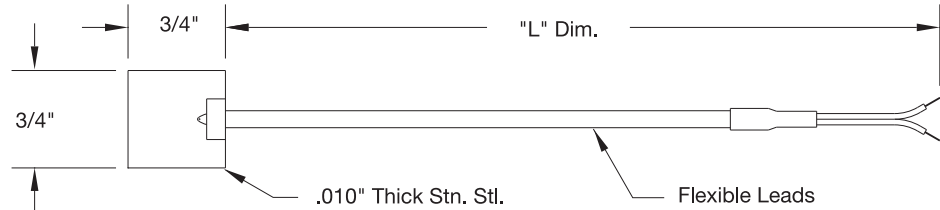

Ordering Code: **TSW** -

Calibration BOX 1

ANSI Standard Tolerances **J K E T N**

"L" Dimension BOX 2

Whole inches
Example: Enter **048** for 48 inches

Lead Insulation BOX 3

Fiberglass 900°F (482°C) **S** w/ SS Overbraid
Teflon® 400°F (204°C) **T** **B**
D

Termination BOX 4 †

B = 2-1/2 in. Split Leads **P** = Standard Plug **D** = Miniature Plug
S = Spade Lugs **J** = Standard Jack **E** = Miniature Jack
C = Spade Lugs with BX Conn. **K** = Standard Plug and Jack **F** = Mini. Plug and Jack
X = Other (Specify)

Special Requirements BOX 5

X = Specify
0 = None

† See page 14-9 for Termination Style descriptions

WARNING: Cancer and Reproductive Harm - www.P65Warnings.ca.gov.

Pipe Clamp Thermocouples

Design Features

* *Stainless Steel Worm Drive Clamp 1/2" wide*

* *Ideal for Measuring Pipe Temperatures*

* *Thermocouple Junction Grounded to Clamp*

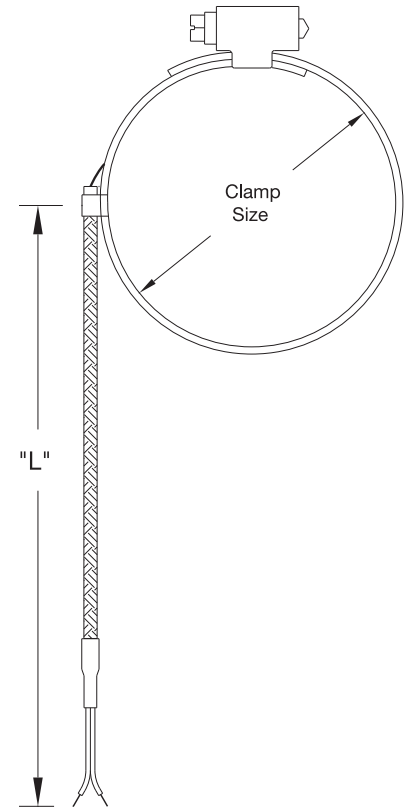

Ordering Code: **TPW** -

Clamp Size BOX 1
 1 = 1/2" to 7/8"
 2 = 7/8" to 1-1/2"
 3 = 1-5/16" to 2-1/4"
 4 = 2-1/4" to 3-5/16"
 5 = 3-5/16" to 4-1/4"
 6 = 4-5/16" to 5-1/4"
 7 = 5-5/8" to 8-1/2" (9/16" Wide)
 X = Other (Specify)

Lead Insulation BOX 4 w/ SS Overbraid
 Fiberglass 900°F (482°C) S B
 Teflon 400°F (204°C) T D

Termination BOX 5 †
 B = 2-1/2 in. Split Leads K = Standard Plug and Jack
 S = Spade Lugs D = Miniature Plug
 C = Spade Lugs with BX Conn. E = Miniature Jack
 P = Standard Plug F = Mini. Plug and Jack
 J = Standard Jack X = Other (Specify)

Calibration BOX 2
 ANSI Standard Tolerances J K E T

† See page 14-9 for Termination Style descriptions

Special Requirements BOX 6
 X = Specify
 0 = None

"L" Dimension BOX 3
 Whole inches
 Example: Enter 048 for 48 inches

Ordering Information

TRW, TSW, TPW and TNW Thermocouples are offered with the options listed in the worksheets. Create an ordering code by filling in the boxes with the appropriate number and/or letter designation for your requirements, and a part number will be assigned.

Design Features

* *Mounted in a shallow threaded hole on the nozzle surface (there is no direct contact with material flow)*

* *Grounded junction*

Nozzle Thermocouples

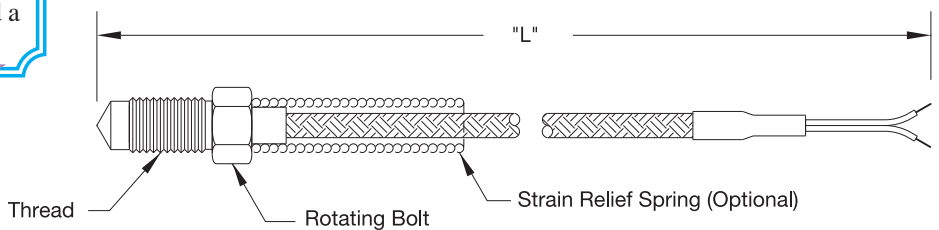

Ordering Code: **TNW** -

Thread Size BOX 1
 1 = 1/4-28 UNF
 2 = 1/4-20 UNC
 3 = M6 x 1
 4 = M8 x 1.25
 X = Other (Specify)

Lead Insulation BOX 4 w/ SS Overbraid
 Fiberglass 900°F (482°C) S B
 Teflon 400°F (204°C) T D

Termination BOX 5 †
 B = 2-1/2 in. Split Leads P = Standard Plug D = Miniature Plug
 S = Spade Lugs J = Standard Jack E = Miniature Jack
 C = Spade Lugs with BX Conn. K = Standard Plug and Jack F = Mini. Plug and Jack
 X = Other (Specify)

Calibration BOX 2
 ANSI Standard Tolerances J K E T N

† See page 14-9 for Termination Style descriptions

"L" Dimension BOX 3
 Whole inches
 Example: Enter 048 for 48 inches

Strain Relief Spring BOX 6
 0 = Not Required
 Y = Required

Special Requirements BOX 7
 X = Specify
 0 = None

WARNING: Cancer and Reproductive Harm - www.P65Warnings.ca.gov



Surface Thermocouples

Wire Thermocouples

* An economical insulated wire thermocouple with exposed junction

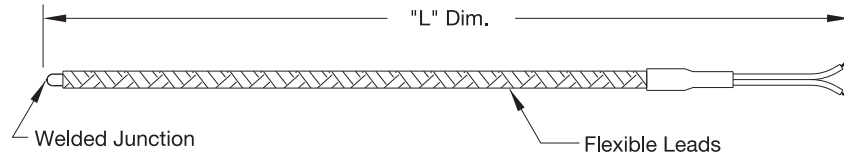

Ordering Code: **TWW** -

Wire Size BOX 1

- 1 = 30 ga. Solid
- 2 = 24 ga. Solid
- 3 = 24 ga. Stranded
- 4 = 20 ga. Solid
- 5 = 20 ga. Stranded
- X = Other (Specify)

Calibration BOX 2

ANSI Standard Tolerances **J K E T**

"L" Dimension BOX 3

Whole inches
Example: Enter **048** for 48 inches

Lead Insulation BOX 4 w/ SS Overbraid

Fiberglass 900°F (482°C) **S** **B**
Teflon® 400°F (204°C) **T** **D**

Termination BOX 5 †

B = 2-1/2 in. Split Leads **P** = Standard Plug **D** = Miniature Plug
S = Spade Lugs **J** = Standard Jack **E** = Miniature Jack
C = Spade Lugs with BX Conn. **K** = Standard Plug and Jack **F** = Mini. Plug and Jack
X = Other (Specify)

Special Requirements BOX 6

X = Specify
0 = None

† See page 14-9 for Termination Style descriptions

Magnet Thermocouples



* This 1-1/4" dia. 6-pole magnet thermocouple can be attached to magnetic surfaces and walls with a holding force of 25 lbs. Magnet may lose some of the holding force above 750°F (400°C).

Ordering Code: **TMW** -

Calibration BOX 1

ANSI Standard Tolerances **J K E T N**

Lead Wire Length BOX 2

Whole inches
Example: Enter **048** for 48 inches

Lead Insulation BOX 3 w/ SS Overbraid

Fiberglass 900°F (482°C) **S** **B**
Teflon® 400°F (204°C) **T** **D**

Termination BOX 4 †

B = 2-1/2 in. Split Leads **P** = Standard Plug **D** = Miniature Plug
S = Spade Lugs **J** = Standard Jack **E** = Miniature Jack
C = Spade Lugs with BX Conn. **K** = Standard Plug and Jack **F** = Mini. Plug and Jack
X = Other (Specify)

Special Requirements BOX 5

X = Specify
0 = None

† See page 14-9 for Termination Style descriptions

⚠ WARNING: Cancer and Reproductive Harm - www.P65Warnings.ca.gov.

View Product Inventory @ www.tempco.com

Optional Thermocouple Termination Styles

Optional Termination Styles

Available for the following thermocouples:

Style	Page
TTW	14-2
TCP	14-3 through 14-5
TRW	14-6
TSW	14-6
TPW	14-7
TNW	14-7
TWW	14-8
TMW	14-8
MTA1	14-15

Style B—Plain Ends

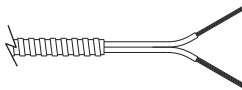

Style S—Spade Lugs

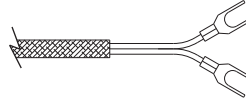

Style C—Spade Lugs with BX connector

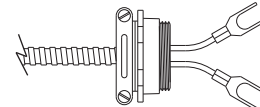

Style P—Standard Plug

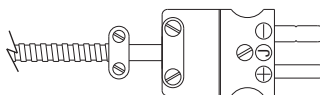

Style J—Standard Jack

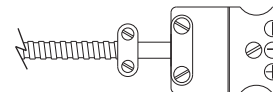

Style D—Miniature Plug

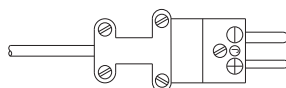

Style E—Miniature Jack

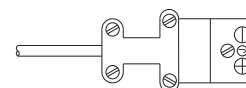

Thermocouple Extension Assemblies

Termination 1

Termination 2

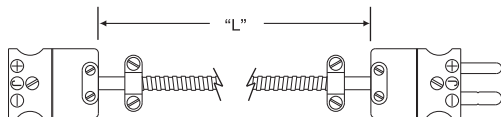

Jack to Plug

Termination 1

Termination 2

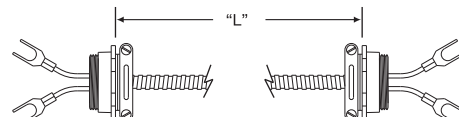

BX Connector to BX Connector

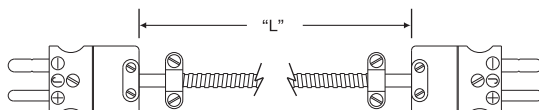

Plug to Plug

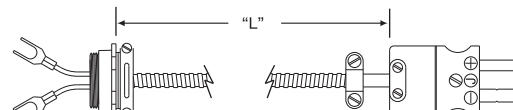

BX Connector to Plug

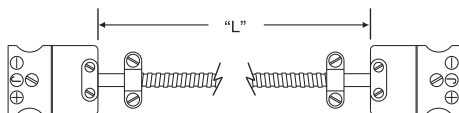

Jack to Jack

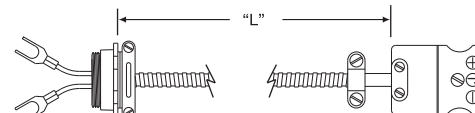

BX Connector to Jack

Ordering Information

ECA Thermocouple Extension Assemblies are offered with the options listed in the worksheet below. Create an ordering code by filling in the boxes with the appropriate number and/or letter designation for your requirements, and a part number will be assigned.

Ordering Code: **ECA** -

Termination 1 & 2 BOX 1 & 2 †

S = Spade Lugs **B** = 2-1/2 in. Split Leads
C = Spade Lugs with BX Conn. **D** = Miniature Plug
P = Standard Plug **E** = Miniature Jack
J = Standard Jack **X** = Other (Specify)

Calibration BOX 3

ANSI Standard Tolerances **J K E T N**

† See above for Termination Style descriptions

"L" Dimension BOX 4

Whole inches **006** to **999**

Lead Insulation BOX 5

	Standard	w/ SS Overbraid	w/ SS Armor Cable
Fiberglass 900°F (482°C)	S	B	A
Teflon® 400°F (204°C)	T	D	F

Special Requirements BOX 6

X = Specify
0 = None

⚠ WARNING: Cancer and Reproductive Harm - www.P65Warnings.ca.gov.

(800) 323-6859 • Email: sales@tempco.com

Melt Bolt Thermocouples

Melt Bolt Thermocouples for Plastic Extruders or Injection Molding Machines

Design Features

*** Bolt Material**

Stainless Steel
1/2-20 UNF Thread

*** Probe Material**

Stainless Steel

*** Probe Diameters**

Standard 1/8"

*** Calibration**

ANSI Type J
(Iron-Constantan)

*** Junction Style**

Closed End Grounded

Style A—Adjustable Tip

- * Eliminates excess inventory.
- * Tip can be field adjusted from flush to 2 inches.
- * MgO insulated.
- * Can be installed wherever standard melt thermocouples are in use.
- * Bolt with Teflon® insert at tip has a maximum operating temperature of 500°F (260°C). Without insert 1400°F (760°C).

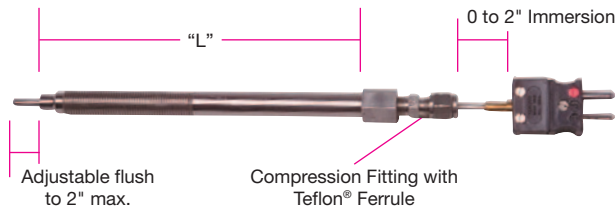

Thermocouple Diameter	Part Number			
	Without Teflon® Insert		With Teflon® Insert	
	L = 3"	L = 6"	L = 3"	L = 6"
1/8"†	TMB00001	TMB00002	TMB00003	TMB00004
3/16"	TMB00005	TMB00006	N/A	N/A

†For 1/8" diameter, it is not recommended to immerse tip more than 1" due to bending and breakage in melt flow.

Style R—Fixed Immersion with No Extension

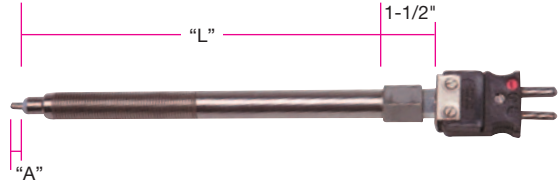

Insulation—MgO or Fiberglass

Part Number MgO Insulation	"A" (in)	"L" (in)	Part Number Fiberglass Insulation
TMB00027	Flush	3	TMB00037
TMB00028	1/4	3	TMB00038
TMB00029	1/2	3	TMB00039
TMB00030	3/4	3	TMB00040
TMB00031	1	3	TMB00041
TMB00032	Flush	6	TMB00042
TMB00033	1/4	6	TMB00043
TMB00034	1/2	6	TMB00044
TMB00035	3/4	6	TMB00045
TMB00036	1	6	TMB00046

Style E—Fixed Immersion with Rigid Extension

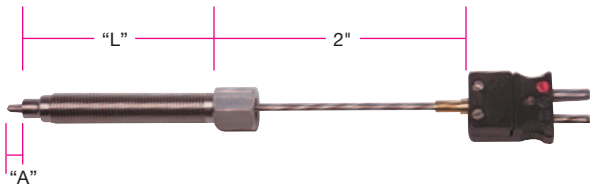

Insulation—MgO or Fiberglass

Part Number MgO Insulation	"A" (in)	"L" (in)	Part Number Fiberglass Insulation
TMB00007	Flush	3	TMB00017
TMB00008	1/4	3	TMB00018
TMB00009	1/2	3	TMB00019
TMB00010	3/4	3	TMB00020
TMB00011	1	3	TMB00021
TMB00012	Flush	6	TMB00022
TMB00013	1/4	6	TMB00023
TMB00014	1/2	6	TMB00024
TMB00015	3/4	6	TMB00025
TMB00016	1	6	TMB00026

Style F—Fixed Immersion with Flexible Extension

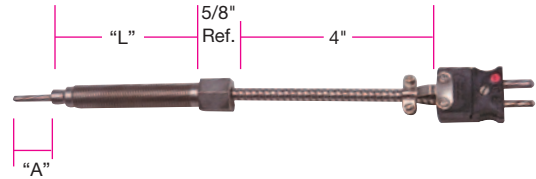

Insulation—Fiberglass only

Stock Items Are Shown In RED

"A" (in)	"L" (in)	Part Number Fiberglass Insulation
Flush	3	TMB00047
1/4	3	TMB00048
1/2	3	TMB00049
3/4	3	TMB00050
1	3	TMB00051
Flush	6	TMB00052
1/4	6	TMB00053
1/2	6	TMB00054
3/4	6	TMB00055
1	6	TMB00056



See page 14-101 for Blank Melt Bolts

Melt Bolt Thermocouples (Custom Engineered/Manufactured)

Design Features

- * Designed to Measure the Temperature of Plastic Stream of an Extruder or Injection Molding Machine
- * 304 Stainless Steel Construction
- * 900°F (482°C) Operating Temperature
- * 1/2-20 UNF Thread

Ordering Information

TMB Melt Bolt Thermocouples are offered with the options listed in the worksheet below. Create an ordering code by filling in the boxes with the appropriate number and/or letter designation for your requirements, and a part number will be assigned.

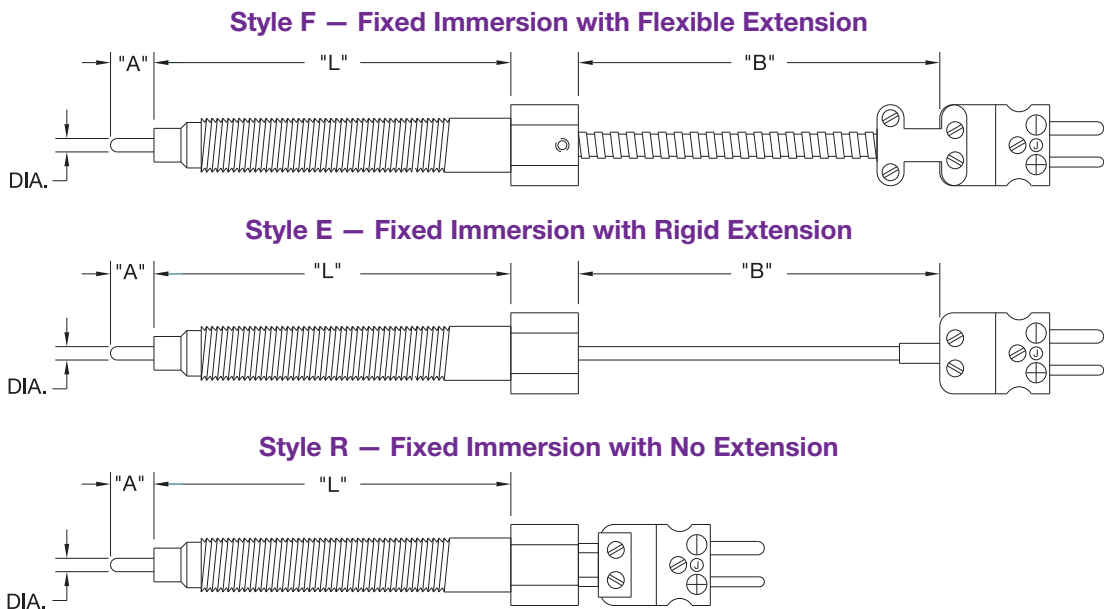

Ordering Code: TMB -

Style BOX 1
F = w/ Flexible Extension
E = w/ Rigid Extension
R = w/ No Extension

Tip Diameter BOX 2
F = 0.125 (Standard)
G = 0.188
X = Other (Specify)

Melt Bolt Length BOX 3
 "L" Dim.
03 = 3" **09** = 9"
04 = 4" **10** = 10"
06 = 6" **12** = 12"

Calibration BOX 4
 ANSI Standard Tolerances **J** **K** **E** **T** **N**

"A" Dimension BOX 5
 Whole inches
0 to **9** (Enter 0 if less than 1)

Junction BOX 7
G = Grounded
U = Ungrounded

"B" Dimension BOX 8
 Whole inches
 Example: Enter **006** for 6 inches
 Enter **000** for Style R

"A" Dimension BOX 6
 Fractional inches
0 = 0" **3** = 3/8" **6** = 3/4"
1 = 1/8" **4** = 1/2" **7** = 7/8"
2 = 1/4" **5** = 5/8"

Termination BOX 9 †
B = 2-1/2 in. Split Leads (Style F only) **P** = Standard Plug
S = Spade Lugs (Style F only) **J** = Standard Jack
C = Spade Lugs with BX Conn. (Style F only) **K** = Standard Plug and Jack
X = Other (Specify)

Special Requirements BOX 10
X = Specify
0 = None

† See page 14-9 for Termination Style descriptions

WARNING: Cancer and Reproductive Harm - www.P65Warnings.ca.gov

(800) 323-6859 • Email: sales@tempco.com

MI Cable Thermocouple Assemblies

Mineral Insulated Metal-Sheathed Cable

Thermocouple Assemblies are made from TEMPCO's high quality Tempco-Pak and will incorporate all the same outstanding features.

Important Features:

- * *Accurate*
- * *High Temperature Rating*
- * *Fast Response*
- * *Moisture Proof*
- * *Thermal Shock Resistant*
- * *Can Be Formed*
- * *Weldable*
- * *High Pressure Rated*
- * *Compact*
- * *Durable*

Typical Applications

- ↔ *Bearing Temperature*
- ↔ *Diesel Engines*
- ↔ *Food Processing*
- ↔ *Furnaces*
- ↔ *Glass Manufacturing*
- ↔ *Heat Treating*
- ↔ *Kilns*
- ↔ *Metal Processing*
- ↔ *Oil Processing*
- ↔ *Ovens*
- ↔ *Petrochemicals*
- ↔ *Power Stations*
- ↔ *Refineries*
- ↔ *Research Laboratories*
- ↔ *Steam Generators*
- ↔ *Turbines*

Hot Junctions

(Hot or Measuring Junctions available on single or dual element cable)

Choose the measuring junction that best suits your particular needs:



Exposed Junction (E)

Thermocouple wires are butt-welded. Insulation is sealed against liquid or gas penetration prior to use.

This junction style provides the fastest possible response time but leaves the thermocouple wires unprotected against corrosive or mechanical damage.



Grounded Junction (G)

The sheath and thermocouple wires are welded together, forming a completely sealed integral junction. Recommended in presence of liquids, moisture, gas or high pressure. The wire is protected from corrosive or erosive conditions. In the Grounded Junction, response time approaches that of the Exposed Junction.



Ungrounded Junction (U)

Thermocouple junction is fully insulated from welded sheath end. Excellent for applications where stray emf's would affect the reading and for frequent or rapid temperature cycling. With the Ungrounded Junction, response time is slightly longer than for the Grounded Junction.



Selecting the Correct Tempco-Pak Thermocouple Assembly

Thermocouples must be selected to meet the conditions of each particular application. The environment, operating temperature and atmosphere, response time and length of service must be considered when selecting the sheath, insulation, calibration, junction and termination of the thermocouple assembly.

Refer to the Mineral Insulated Thermocouples and Cable section regarding sheath, insulation and calibration (pages 14-114 through 14-118).

TEMPCO's engineering staff will be happy to assist you with the design and selection of your thermocouple requirements.

Sheath Materials

The most commonly used sheath materials and their maximum continuous operating temperatures in an oxidizing atmosphere are as follows:

Sheath Material	Max. Operating Temperature
Alloy 600	2150°F (1177°C)
304 Stainless Steel	1650°F (899°C)
316 Stainless Steel	1650°F (899°C)
310 Stainless Steel	2100°F (1150°C)



Note: For temperatures exceeding 2200°F (1204°C), Noble or Refractory metal sheaths are normally used.

Formability

Because Tempco-Pak is fully annealed it can normally be formed around a mandrel 4 times the sheath diameter. Consult TEMPCO if special forming is required.

Weldability

The thermocouple sheath can be brazed, soldered or welded. Welding the thermocouple sheath in the field is not recommended on diameters less than .093 in. All welding should be done in an inert atmosphere.

Calibrations

The table shows the standard temperature ranges for the various ANSI thermocouple calibrations:

ANSI Letter	Thermocouple Type	Temperature Range	
		°F	(°C)
J	Iron-Constantan	32-1400	(0-760)
K	CHROMEL P®-ALUMEL®	32-2300	(0-1260)
N	Nicrosil-Nisil	32-2300	(0-1260)
T	Copper-Constantan	32-660	(0-350)
E	CHROMEL P®-Constantan	32-1600	(0-871)
R	Pt 13% Rhodium-Platinum	32-2700	(0-1482)
S	Pt 10% Rhodium-Platinum	32-2700	(0-1482)
B	Pt 30% Rh-Pt 6% Rh	1600-3100	(871-1704)

Assembly Tolerances: Sheath Length Dimensions

Sheath O.D.	"L" Tolerance Up to 24"	"L" Tolerance Over 24"
Up to .038"	±½"	±2%
.038" to .065"	±¾"	±1½%
Larger than .065"	±¼"	±1%

Flexible Lead Dimensions

Lead Length (ft.)	Tolerance
Up to 5	+6", -1"
5 to 10	+6", -2"
over 10	+5%, -2%



Style MTA1 — Transition to Lead Wire (Stock)

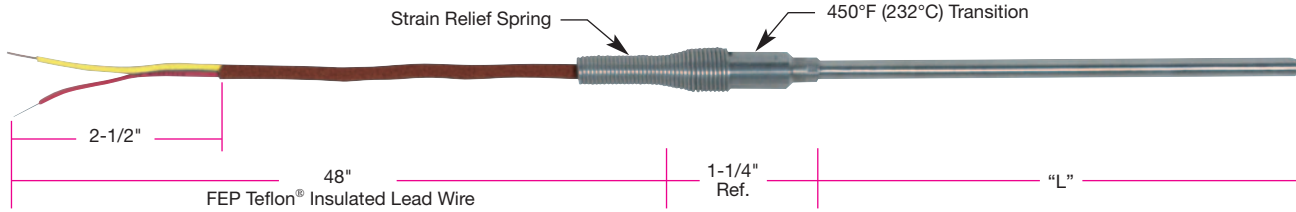

Ordering a Stock MTA1 Thermocouple

(Thermocouples not available from stock can be custom manufactured—see page 14-15)

TEMPCO stocks **MTA1 style Thermocouples** in type J and K in the standard lengths listed in the following two tables. These thermocouples have Teflon® insulated leads with a 2-1/2" split lead termination.

Order a stock unit from the tables after completing the ordering code with the Junction Type Code from Box 5 and Optional Compression Fitting Code from Box 6 below.

Type J — 316 SS Sheath

Diameter	"L" Dimension			
	6"	12"	18"	24"
0.063"	ST1-JD06B <input type="checkbox"/>	ST1-JD12B <input type="checkbox"/>	ST1-JD18B <input type="checkbox"/>	ST1-JD24B <input type="checkbox"/>
0.125"	ST1-JF06B <input type="checkbox"/>	ST1-JF12B <input type="checkbox"/>	ST1-JF18B <input type="checkbox"/>	ST1-JF24B <input type="checkbox"/>
0.250"	ST1-JH06B <input type="checkbox"/>	ST1-JH12B <input type="checkbox"/>	ST1-JH18B <input type="checkbox"/>	ST1-JH24B <input type="checkbox"/>

Type K — Alloy 600 Sheath

Diameter	"L" Dimension			
	6"	12"	18"	24"
0.063"	ST1-KD06B <input type="checkbox"/>	ST1-KD12B <input type="checkbox"/>	ST1-KD18B <input type="checkbox"/>	ST1-KD24B <input type="checkbox"/>
0.125"	ST1-KF06B <input type="checkbox"/>	ST1-KF12B <input type="checkbox"/>	ST1-KF18B <input type="checkbox"/>	ST1-KF24B <input type="checkbox"/>
0.250"	ST1-KH06B <input type="checkbox"/>	ST1-KH12B <input type="checkbox"/>	ST1-KH18B <input type="checkbox"/>	ST1-KH24B <input type="checkbox"/>

Stock Modification for Fast Delivery

Above stocked items can be cut to desired length and terminated with any standard termination for fast delivery. To order a probe length not listed in the tables above, complete the Code Number below.

Ordering Code: **ST1** -

Calibration BOX 1
ANSI Standard Tolerances **J K**

Diameter BOX 2
D = .063"
F = .125"
H = .250"

"L" Dimension BOX 3
06", 12", 18", 24" Stock Lengths
For other lengths, specify in inches.

Termination BOX 4
B = 2-1/2 in. Split Leads
S = Spade Lugs
C = Spade Lugs with BX Conn.
P = Standard Plug
J = Standard Jack
K = Standard Plug and Jack
D = Miniature Plug
E = Miniature Jack
F = Mini. Plug and Jack
See page 14-9 for Termination Style descriptions

Junction BOX 5
G = Grounded
U = Ungrounded
E = Exposed

Optional Compression Fitting BOX 6
1 = 1/8" NPT SS **4** = 1/8" NPT Brass
2 = 1/4" NPT SS **5** = 1/4" NPT Brass
3 = 1/2" NPT SS **6** = 1/2" NPT Brass
0 = None Required



Optional Installation Compression Fitting
See Box 6

WARNING: Cancer and Reproductive Harm - www.P65Warnings.ca.gov.



Style MTA1 — Transition to Lead Wire (Custom Manufactured)

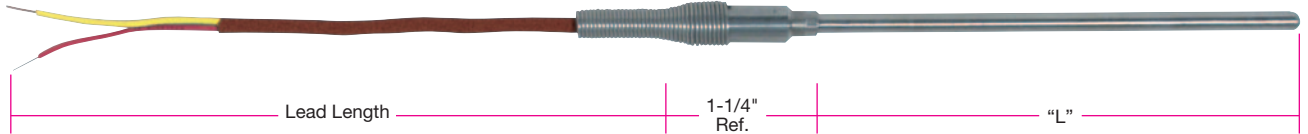

Ordering Information

Thermocouples are offered with the options listed in the worksheet below. Create an ordering code by filling in the boxes with the appropriate number and/or letter designation for your requirements, and a part number will be assigned.



Optional Installation Compression Fitting
See Box 13

Design Features

- * Mineral insulated sheath provides flexibility to form and bend the thermocouple to meet design requirements.
- * Stainless steel transition with optional Strain Relief Spring
- * Standard epoxy potting transition provides greater moisture resistance rated to 450°F (232°C). Optional ceramic based potting rated to 1000°F (538°C). Ceramic potting not recommended with Teflon® leads, nor for high humidity applications.

Ordering Code:

MTA1 -

Calibration Code BOX 1

ANSI Standard Tolerances	J	K	E	T	N	R	S	B
Special Tolerances	3	4	5	6	7			

Junction BOX 8

	Grounded	Ungrounded	Exposed
Single	G	U	E
Dual, common	4	5	6
Dual, isolated	—	7	8

Lead Wire Length BOX 9

In inches **001 to 999**
12" (012) Standard

Number of Conductors BOX 2

2 = Single (Standard)
4 = Duplex

Insulation BOX 3

M = 96% min. MgO (Standard)
H = 99.4% min. MgO

Sheath Material BOX 4

A = Alloy 600
B = 304 SS
C = 316 SS

Sheath O.D. BOX 5

A = .020" ±.001	K = .375" +.003/- .002
B = .032" ±.001	L = 1.0mm ±.03
C = .040" ±.001	N = 1.5mm ±.03
D = .063" ±.001	P = 2.0 mm ±.03
E = .093" ±.002	Q = 3.0 mm ±.03
F = .125" ±.002	R = 4.5 mm ±.05
G = .188" ±.002	S = 6.0 mm +.07/- .05
H = .250" +.003/- .002	T = 8.0 mm +.07/- .05
J = .313" +.003/- .002	V = 9.0 mm +.07/- .05

Sheath Length "L" BOX 6

Whole inches
01 to 99
For lengths over 99 in. consult TEMPCO.

Sheath Length "L" BOX 7

Fractional inches		
0 = 0"	3 = 3/8"	6 = 3/4"
1 = 1/8"	4 = 1/2"	7 = 7/8"
2 = 1/4"	5 = 5/8"	

Lead Wire Construction BOX 10

		w/ SS Overbraid	w/ SS Flex Armor
Fiberglass 900°F (482°C)	S	B	A
Teflon 400°F (204°C)	T	D	F

Depending on availability .040" to .125" uses 24 gauge lead wire. Larger than .125" thermocouples use 20 gauge lead wire depending on availability and insulation type.

Lead Wire Termination BOX 11

P = Standard Male Plug	F = Miniature Plug with Mating Jack
J = Standard Female Jack	B = Standard—2-1/2 in. Split Leads
K = Std. Plug with Mating Conn.	S = 2-1/2 in. Split Leads with Spade Lugs
D = Miniature Male Plug	C = 2-1/2 in. Split Leads with BX connector and Spade Lugs
E = Miniature Female Jack	X = Other (Specify)

See page 14-9 for Termination Style descriptions

Strain Relief Spring BOX 12

O = Not Required
Y = Required

Optional Compression Fitting BOX 13

1 = 1/8" NPT SS	4 = 1/8" NPT Brass
2 = 1/4" NPT SS	5 = 1/4" NPT Brass
3 = 1/2" NPT SS	6 = 1/2" NPT Brass
0 = None Required	

Special Requirements BOX 14

H = High temp potting 1000°F (538°C)
O = Standard Epoxy Potting 450°F (232°C)
X = Other (Specify)

WARNING: Cancer and Reproductive Harm - www.P65Warnings.ca.gov.

(800) 323-6859 • Email: sales@tempco.com



Style MTA2 Plug Termination (Stock)

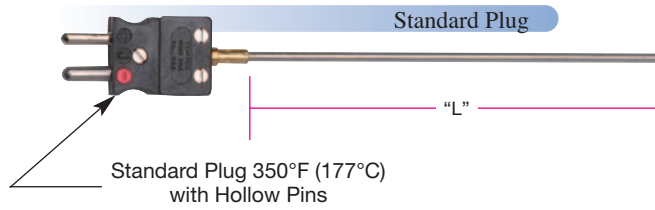

Ordering a Stock MTA2 Thermocouple

(Thermocouples not available from stock can be custom manufactured—see page 14-17)

TEMPCO stocks **MTA2 style Thermocouples** in type J and K in the standard lengths listed in the following two tables. These thermocouples have a standard Male Plug Termination.

Order a stock unit from the tables after completing the ordering code with the Junction Type Code from Box 4 and Optional Compression Fitting Code from Box 5 below.

Type J – 316 SS Sheath

Diameter	"L" Dimension			
	6"	12"	18"	24"
0.063"	ST2-JD06 <input type="checkbox"/>	ST2-JD12 <input type="checkbox"/>	ST2-JD18 <input type="checkbox"/>	ST2-JD24 <input type="checkbox"/>
0.125"	ST2-JF06 <input type="checkbox"/>	ST2-JF12 <input type="checkbox"/>	ST2-JF18 <input type="checkbox"/>	ST2-JF24 <input type="checkbox"/>

Type K – Alloy 600 Sheath

Diameter	"L" Dimension			
	6"	12"	18"	24"
0.063"	ST2-KD06 <input type="checkbox"/>	ST2-KD12 <input type="checkbox"/>	ST2-KD18 <input type="checkbox"/>	ST2-KD24 <input type="checkbox"/>
0.125"	ST2-KF06 <input type="checkbox"/>	ST2-KF12 <input type="checkbox"/>	ST2-KF18 <input type="checkbox"/>	ST2-KF24 <input type="checkbox"/>

Stock Modification for Fast Delivery

Above stocked items can be cut to desired length and junctioned for fast delivery. To order a probe length not listed in the tables above, complete the Code Number below.

Ordering Code: **ST2** -

Calibration BOX 1
ANSI Standard Tolerances **J K**

"L" Dimension BOX 3
06", 12", 18", 24" Stock Lengths
For other lengths specify in inches.

Optional Compression Fitting BOX 5
1 = 1/8" NPT SS **4** = 1/8" NPT Brass
2 = 1/4" NPT SS **5** = 1/4" NPT Brass
3 = 1/2" NPT SS **6** = 1/2" NPT Brass
0 = None Required

Diameter BOX 2
D = .063"
F = .125"

Junction BOX 4
G = Grounded
U = Ungrounded
E = Exposed



Optional Installation Compression Fitting
See Box 5

WARNING: Cancer and Reproductive Harm - www.P65Warnings.ca.gov.

Style MTA2 Plug or Jack Termination (Custom Manufactured)

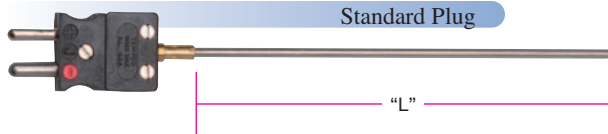

Standard Plug

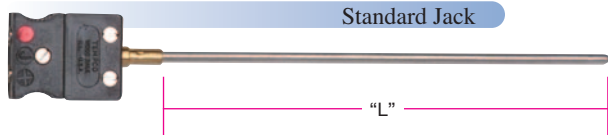

Standard Jack

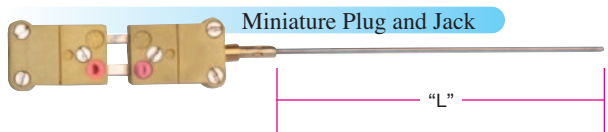

Miniature Plug and Jack



Optional Installation
Compression Fitting
See Box 12

Design Features

- * Pins are made with matching thermocouple alloys.
- * Standard plugs come with hollow pins as standard and solid pins as an option.
- * Standard size and miniature plugs and jacks have a 350°F (177°C) continuous and 400°F (204°C) intermittent temperature rating.
- * High temperature plugs and jacks are rated for 500°F (260°C) continuous operation and 550°F (288°C) intermittent (brown only).
- * Ultra high temperature plugs and jacks are rated for 800°F (427°C) continuous operation and 1000°F (538°C) intermittent (all are reddish-brown in color).
- * Dual element available for sheath O.D. of 0.063" to 0.375".
- * 0.020" to 0.250" use crimp insert—0.313" and 0.375" use tube adapters.
- * Miniature plugs have solid flat pins.

Ordering Information

Thermocouples are offered with the options listed in the worksheet below. Create an ordering code by filling in the boxes with the appropriate number and/or letter designation for your requirements, and a part number will be assigned.

Ordering Code:

MTA2 - 1 2 3 4 5 6 7 8 9 10 11 12 13

Calibration Code BOX 1

ANSI Standard Tolerances **J K E T N R S B**
Special Tolerances **3 4 5 6 7**

Number of Conductors BOX 2

2 = Single (Standard)
4 = Duplex

Connector Type BOX 9

Standard Plugs and Jacks
P = Standard Plug
J = Standard Jack
K = Standard Plug w/Mating Jack
Miniature Plugs and Jacks (.188" max O.D.)
D = Miniature Plug
E = Miniature Jack
F = Miniature Plug w/Mating Jack

Insulation BOX 3

M = 96% min. MgO (Standard)
H = 99.4% min. MgO

Sheath Material BOX 4

A = Alloy 600 B = 304 SS C = 316 SS

Sheath O.D. BOX 5

A = .020" ±.001	G = .188" ±.002	P = 2.0mm ±.03
B = .032" ±.001	H = .250" +.003/- .002	Q = 3.0mm ±.03
C = .040" ±.001	J = .313" +.003/- .002	R = 4.5mm ±.05
D = .063" ±.001	K = .375" +.003/- .002	S = 6.0mm +.07/- .05
E = .092" ±.001	L = 1.0mm ±.03	T = 8.0mm +.07/- .05
F = .125" ±.002	N = 1.5mm ±.03	V = 9.0mm +.07/- .05

Connector Temp Rating BOX 10

S = Standard 350°F (177°C)
H = High Temperature 500°F (260°C)
U = Ultra-High Temperature 800°F (427°C)
(Miniature not available)

Sheath Length "L" BOX 6

Whole inches
01 to 99
For lengths over 99 in. consult TEMPCO.

Sheath Length "L" BOX 7

Fractional inches
0 = 0" 3 = 3/8" 6 = 3/4"
1 = 1/8" 4 = 1/2" 7 = 7/8"
2 = 1/4" 5 = 5/8"

Pin Option BOX 11

H = Hollow pins—std. S = Solid pins O = For Jack Termination

Junction BOX 8

	Grounded	Ungrounded	Exposed
Single	G	U	E
Dual, common	4	5	6
Dual, isolated	—	7	8

Optional Compression Fitting BOX 12

1 = 1/8" NPT SS 4 = 1/8" NPT Brass
2 = 1/4" NPT SS 5 = 1/4" NPT Brass
3 = 1/2" NPT SS 6 = 1/2" NPT Brass
0 = None Required

Special Requirements BOX 13

X = Specify
0 = None

WARNING: Cancer and Reproductive Harm - www.P65Warnings.ca.gov.

(800) 323-6859 • Email: sales@tempco.com



Style MTA4 Stripped Cold End (Stock)

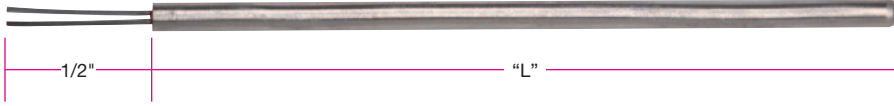

Design Features

- * Standard strip length is 1/2 inch.
- * Stripped end sealed with resin to inhibit moisture penetration.

All Items Available from Stock

Ordering a Stock MTA4 Thermocouple

(Thermocouples not available from stock can be custom manufactured—see page 14-19)

TEMPCO stocks **MTA4 style Thermocouples** in type J and K in the standard lengths listed in the following two tables. These thermocouples have a 1/2-inch strip length.

Order a stock unit from the tables after completing the ordering code with the Junction Type Code from Box 4 and Optional Compression Fitting Code from Box 5 below.

Stock Type J – 316 SS Sheath

Diameter	"L" Dimension			
	7"	13"	19"	25"
0.063"	ST4JD07 <input type="checkbox"/>	ST4JD13 <input type="checkbox"/>	ST4JD19 <input type="checkbox"/>	ST4JD25 <input type="checkbox"/>
0.125"	ST4JF07 <input type="checkbox"/>	ST4JF13 <input type="checkbox"/>	ST4JF19 <input type="checkbox"/>	ST4JF25 <input type="checkbox"/>
0.188"	ST4JG07 <input type="checkbox"/>	ST4JG13 <input type="checkbox"/>	ST4JG19 <input type="checkbox"/>	ST4JG25 <input type="checkbox"/>
0.250"	ST4JH07 <input type="checkbox"/>	ST4JH13 <input type="checkbox"/>	ST4JH19 <input type="checkbox"/>	ST4JH25 <input type="checkbox"/>

Stock Type K – Alloy 600 Sheath

Diameter	"L" Dimension			
	7"	13"	19"	25"
0.063"	ST4KD07 <input type="checkbox"/>	ST4KD13 <input type="checkbox"/>	ST4KD19 <input type="checkbox"/>	ST4KD25 <input type="checkbox"/>
0.125"	ST4KF07 <input type="checkbox"/>	ST4KF13 <input type="checkbox"/>	ST4KF19 <input type="checkbox"/>	ST4KF25 <input type="checkbox"/>
0.188"	ST4KG07 <input type="checkbox"/>	ST4KG13 <input type="checkbox"/>	ST4KG19 <input type="checkbox"/>	ST4KG25 <input type="checkbox"/>
0.250"	ST4KH07 <input type="checkbox"/>	ST4KH13 <input type="checkbox"/>	ST4KH19 <input type="checkbox"/>	ST4KH25 <input type="checkbox"/>

Stock Modification for Fast Delivery

Above stocked items can be cut to desired length and stripped as required for fast delivery. To order a probe length not listed in the tables above, complete the Code Number below.

Ordering Code: **ST4** - ¹ ² ³ ⁴ ⁵

Calibration BOX 1
ANSI Standard Tolerances **J K**

Diameter BOX 2
D = .063"
F = .125"
G = .188"
H = .250"

"L" Dimension BOX 3
07", 13", 19", 25" Stock Lengths
For other lengths specify in inches.

Junction BOX 4
G = Grounded
U = Ungrounded
E = Exposed

Optional Compression Fitting BOX 5
1 = 1/8" NPT SS **4** = 1/8" NPT Brass
2 = 1/4" NPT SS **5** = 1/4" NPT Brass
3 = 1/2" NPT SS **6** = 1/2" NPT Brass
0 = None Required



Optional Installation Compression Fitting
See Box 5

WARNING: Cancer and Reproductive Harm - www.P65Warnings.ca.gov.



Style MTA4 Stripped Cold End (Custom Manufactured)

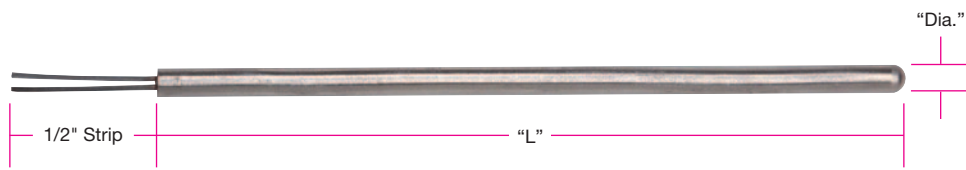

Design Features

- * Standard strip length is 1/2 inch.
- * Stripped end sealed with resin to inhibit moisture penetration.
- * Duplex available from 0.063" to 0.375" diameter.

Ordering Information

Thermocouples are offered with the options listed in the worksheet below. Create an ordering code by filling in the boxes with the appropriate number and/or letter designation for your requirements, and a part number will be assigned.



**Optional Installation
Compression Fitting**
See Box 10

Ordering Code: **MTA4** -

Calibration Code BOX 1

ANSI Standard Tolerances **J K E T N R S B**
Special Tolerances **3 4 5 6 7**

Sheath Length "L" BOX 6

Whole inches
01 to 99
 For lengths over 99 in. consult TEMPCO.

Sheath Length "L" BOX 7

Fractional inches
0 = 0" 3 = 3/8" 6 = 3/4"
1 = 1/8" 4 = 1/2" 7 = 7/8"
2 = 1/4" 5 = 5/8"

Number of Conductors BOX 2

2 = Single (Standard)
4 = Duplex

Insulation BOX 3

M = 96% min. MgO (Standard)
H = 99.4% min. MgO

Sheath Material BOX 4

A = Alloy 600
B = 304 SS
C = 316 SS

Sheath O.D. BOX 5

B = .032" ±.001 H = .250" +.003/-0.002 Q = 3.0mm ±.03
C = .040" ±.001 J = .313" +.003/-0.002 R = 4.5mm ±.05
D = .063" ±.001 K = .375" +.003/-0.002 S = 6.0mm +.07/-0.05
E = .092" ±.001 L = 1.0mm ±.03 T = 8.0mm +.07/-0.05
F = .125" ±.002 N = 1.5mm ±.03 V = 9.0mm +.07/-0.05
G = .188" ±.002 P = 2.0mm ±.03

Junction BOX 8

	Grounded	Ungrounded	Exposed
Single	G	U	E
Dual, common	4	5	6
Dual, isolated	-	7	8

Strip Length BOX 9

S = 1/2" standard
1 = 1"
2 = 2"
3 = 3"
 1" maximum on .040" and smaller

Optional Compression Fitting BOX 10

1 = 1/8" NPT SS 4 = 1/8" NPT Brass
2 = 1/4" NPT SS 5 = 1/4" NPT Brass
3 = 1/2" NPT SS 6 = 1/2" NPT Brass
0 = None Required

Special Requirements BOX 11

X = Specify
0 = None

⚠ WARNING: Cancer and Reproductive Harm - www.P65Warnings.ca.gov.

Temperature Sensing

MI Cable Thermocouple Assemblies



Style MTA3 — Open Disc Termination

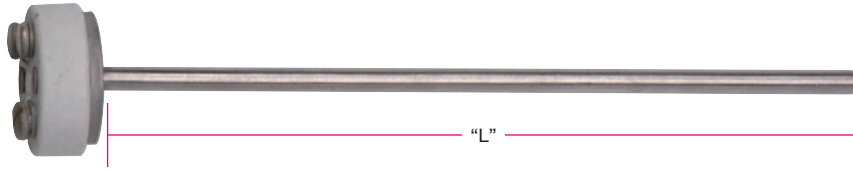

Design Features

- * Economical termination with nickel plated brass inserts.
- * Available in sheath diameters ranging from 0.063" to 0.250", single and duplex construction.

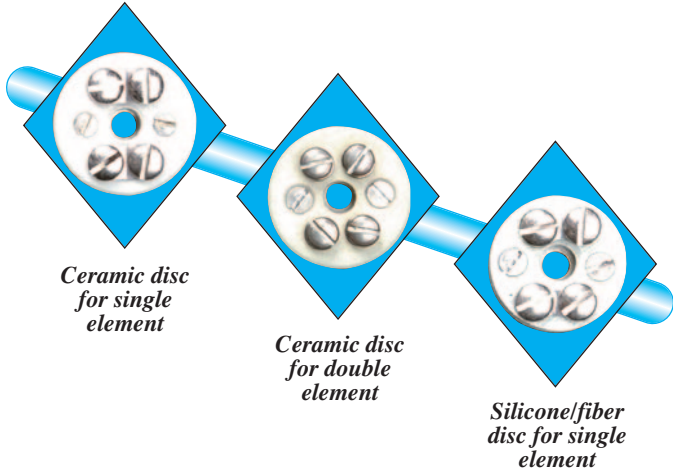

Optional Installation
Compression Fitting
See Box 10

Ordering Information

Thermocouples are offered with the options listed in the worksheet below. Create an ordering code by filling in the boxes with the appropriate number and/or letter designation for your requirements, and a part number will be assigned.

Ordering Code: **MTA3** -

Calibration Code BOX 1

ANSI Standard **J K E T N R S B**
Tolerances
Special Tolerances **3 4 5 6 7**

Sheath Length "L" BOX 6

Whole inches
01 to 99
For lengths over 99 in. consult TEMPSCO.

Sheath Length "L" BOX 7

Fractional inches
0 = 0" **3** = 3/8" **6** = 3/4"
1 = 1/8" **4** = 1/2" **7** = 7/8"
2 = 1/4" **5** = 5/8"

Number of Conductors BOX 2

2 = Single (Standard)
4 = Duplex

Junction BOX 8

	Grounded	Ungrounded	Exposed
Single	G	U	E
Dual, common	4	5	6
Dual, isolated	-	7	8

Insulation BOX 3

M = 96% min. MgO (Standard)
H = 99.4% min. MgO

Termination BOX 9

1* = Silicone/glass cloth to 350°F (177°C) 1" O.D. with Brass mounting plate
2 = Ceramic to 1000°F (538°C) 1-1/8" O.D. Single and Dual element with SS mounting plate
* Single element only

Sheath Material BOX 4

A = Alloy 600
B = 304 SS
C = 316 SS

Optional Compression Fitting BOX 10

1 = 1/8" NPT SS **4** = 1/8" NPT Brass
2 = 1/4" NPT SS **5** = 1/4" NPT Brass
3 = 1/2" NPT SS **6** = 1/2" NPT Brass
0 = None Required

Sheath O.D. BOX 5

D = .063" ±.001 **G** = .188" ±.002 **Q** = 3.0 mm ±.03
E = .092" ±.001 **H** = .250" +.003/- .002 **R** = 4.5 mm ±.05
F = .125" ±.002 **P** = 2.0 mm ±.03 **S** = 6.0 mm +.07/- .05

Special Requirements BOX 11

X = Specify
0 = None

⚠ WARNING: Cancer and Reproductive Harm - www.P65Warnings.ca.gov.



Style MTA5 — Connection Head

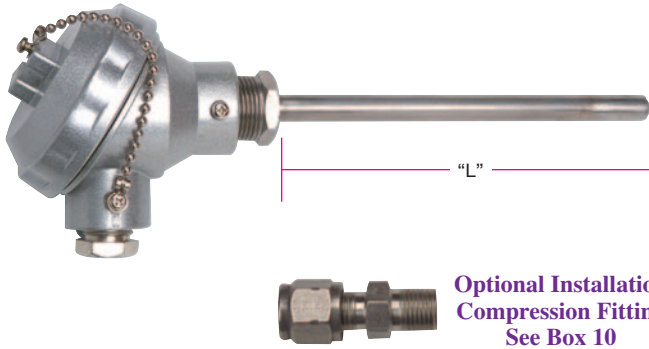

Design Features

- * Tempco's connection heads are gasketed to seal against moisture, dust and corrosive or hostile atmospheres.
- * Screw covers are attached to body with a plated chain.
- * Covers have lugs for tightening or loosening with a screwdriver or wrench.
- * Available in single (2-wire) or duplex (4-wire).
- * Tempco's connection heads are available in die cast aluminum, Bakelite and cast iron in a variety of sizes from miniature for confined areas to the large universal head designed for heavy process and industrial applications. See sensor accessories pages 14-98 through 14-100 for complete information.

Ordering Information

Thermocouples are offered with the options listed in the work-sheet below. Create an ordering code by filling in the boxes with the appropriate number and/or letter designation for your requirements, and a part number will be assigned.

Ordering Code: **MTA5** -

Calibration Code BOX 1

ANSI Standard Tolerances **J K E T N R S B**

Special Tolerances **3 4 5 6 7**

Sheath Length "L" BOX 6

Whole inches **01 to 99**

For lengths over 99 in. consult TEMPCO.

Sheath Length "L" BOX 7

Fractional inches

0 = 0"	3 = 3/8"	6 = 3/4"
1 = 1/8"	4 = 1/2"	7 = 7/8"
2 = 1/4"	5 = 5/8"	

Number of Conductors BOX 2

2 = Single (Standard)

4 = Duplex

Junction BOX 8

	Grounded	Ungrounded	Exposed
Single	G	U	E
Dual, common	4	5	6
Dual, isolated	—	7	8

Insulation BOX 3

M = 96% min. MgO (Standard)

H = 99.4% min. MgO

Connection Head BOX 9

A = Standard Size Aluminum	F = Standard Bakelite
B = Medium Size Aluminum	P = Polypropylene
C = Miniature Aluminum	N = Miniature Nickel Plated Steel
H = Standard Cast Iron	S = Stainless Steel

Note: Conduit connection for A, F, H & S is 1/2" (3/4" is available); for B & C is 3/8"; and for P is 3/4" NPT.

For overall dimensions see pages 14-98 through 14-100.

Sheath Material BOX 4

A = Alloy 600

B = 304 SS

C = 316 SS

Sheath O.D. BOX 5

D = .063" ±.001	P = 2.0 mm ±.03
F = .125" ±.002	Q = 3.0 mm ±.03
G = .188" ±.002	R = 4.5 mm ±.05
H = .250" +.003/-.002	S = 6.0 mm +.07/-.05
J = .313" +.003/-.002	
K = .375" +.003/-.002	

Optional Compression Fitting BOX 10

1 = 1/8" NPT SS	4 = 1/8" NPT Brass
2 = 1/4" NPT SS	5 = 1/4" NPT Brass
3 = 1/2" NPT SS	6 = 1/2" NPT Brass
0 = None Required	

Special Requirements BOX 11

X = Specify

0 = None

WARNING: Cancer and Reproductive Harm - www.P65Warnings.ca.gov.

(800) 323-6859 • Email: sales@tempco.com

Style MTA6 Connection Head with 1/2" NPT Hex Nipple (Stock)

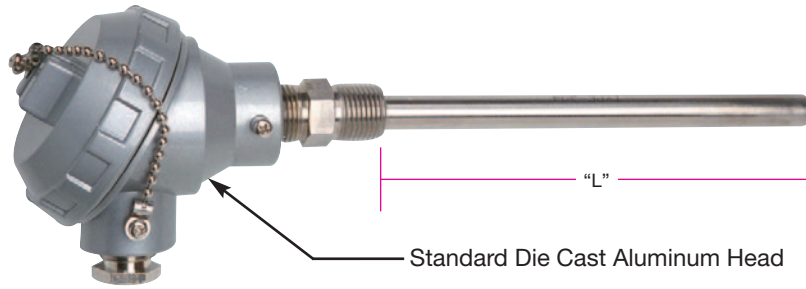

Ordering a Stock MTA6 Thermocouple

(Thermocouples not available from stock can be custom manufactured—see page 14-23)

TEMPCO stocks **MTA6 style Thermocouples** in type J and K in the standard lengths listed in the following two tables. These thermocouples have a 1/2" NPT SS process connection with a standard die cast aluminum head (Type A)

Order a stock unit from the tables after completing the ordering code with the Junction Type Code from Box 4 below.

Stock Type J – 316 SS Sheath

Diameter	"L" Dimension			
	6"	12"	18"	24"
0.125"	ST6JF06 <input type="checkbox"/>	ST6JF12 <input type="checkbox"/>	ST6JF18 <input type="checkbox"/>	ST6JF24 <input type="checkbox"/>
0.188"	ST6JG06 <input type="checkbox"/>	ST6JG12 <input type="checkbox"/>	ST6JG18 <input type="checkbox"/>	ST6JG24 <input type="checkbox"/>
0.250"	ST6JH06 <input type="checkbox"/>	ST6JH12 <input type="checkbox"/>	ST6JH18 <input type="checkbox"/>	ST6JH24 <input type="checkbox"/>

Stock Type K – Alloy 600 Sheath

Diameter	"L" Dimension			
	6"	12"	18"	24"
0.125"	ST6KF06 <input type="checkbox"/>	ST6KF12 <input type="checkbox"/>	ST6KF18 <input type="checkbox"/>	ST6KF24 <input type="checkbox"/>
0.188"	ST6KG06 <input type="checkbox"/>	ST6KG12 <input type="checkbox"/>	ST6KG18 <input type="checkbox"/>	ST6KG24 <input type="checkbox"/>
0.250"	ST6KH06 <input type="checkbox"/>	ST6KH12 <input type="checkbox"/>	ST6KH18 <input type="checkbox"/>	ST6KH24 <input type="checkbox"/>

Stock Modification

Above stocked items can be cut to desired length and junctioned for fast delivery. For lengths other than listed in table above, complete the Code Number below.

Ordering Code: **ST6** - ¹ ² ³ ⁴

Calibration BOX 1
ANSI Standard Tolerances **J K**

Diameter BOX 2
F = .125"
G = .188"
H = .250"

"L" Dimension BOX 3
06", 12", 18", 24" Stock Lengths
For other lengths specify in inches.

Junction BOX 4
G = Grounded
U = Ungrounded
E = Exposed

WARNING: Cancer and Reproductive Harm - www.P65Warnings.ca.gov.

Style MTA6 (Custom Engineered/Manufactured)

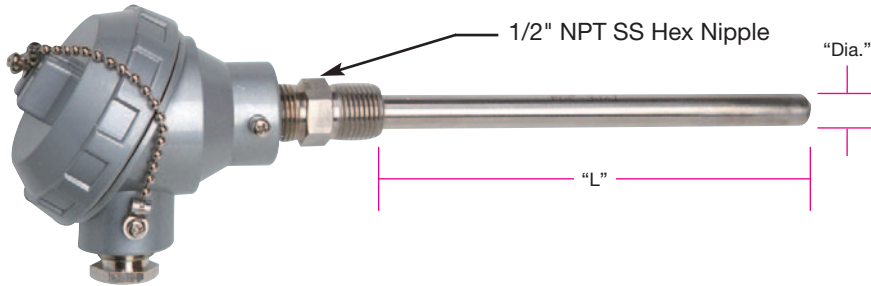

Design Features

- * 1/2" NPT Stainless Steel Process Connection.
- * Tempco's connection heads are gasketed to seal against moisture, dust and corrosive or hostile atmospheres.
- * Screw covers are attached to body with a plated chain.
- * Covers have lugs for tightening or loosening with a screwdriver or wrench.
- * Available in single (2-wire) or duplex (4-wire).
- * Tempco's connection heads are available in die cast aluminum, Bakelite and cast iron in a variety of sizes from miniature for confined areas to the large universal head designed for heavy process and industrial applications. See sensor accessories on pages 14-98 through 14-100 for complete information.

Ordering Information

Thermocouples are offered with the options listed in the worksheet below. Create an ordering code by filling in the boxes with the appropriate number and/or letter designation for your requirements, and a part number will be assigned.

Ordering Code: **MTA6** -

Calibration Code BOX 1

ANSI Standard **J K E T N R S B**
 Tolerances
 Special Tolerances **3 4 5 6 7**

Sheath Length "L" BOX 6

Whole inches
01 to 99
 For lengths over 99 in. consult TEMPCO.

Sheath Length "L" BOX 7

Fractional inches
0 = 0" **3** = 3/8" **6** = 3/4"
1 = 1/8" **4** = 1/2" **7** = 7/8"
2 = 1/4" **5** = 5/8"

Number of Conductors BOX 2

2 = Single (Standard)
4 = Duplex

Junction BOX 8

	Grounded	Ungrounded	Exposed
Single	G	U	E
Dual, common	4	5	6
Dual, isolated	—	7	8

Insulation BOX 3

M = 96% min. MgO (Standard)
H = 99.4% min. MgO

Connection Head BOX 9

A = Standard Size Aluminum **S** = Stainless Steel
B = Medium Size Aluminum **F** = Standard Bakelite
C = Miniature Aluminum **P** = Polypropylene (FDA Approved)
H = Standard Cast Iron

Note: Conduit connection for A, F, H & S is 1/2" (3/4" is available); for B & C is 3/8"; and for P is 3/4" NPT.
 For overall dimensions see pages 14-98 through 14-100.

Sheath Material BOX 4

A = Alloy 600
B = 304 SS
C = 316 SS

Spring-Loaded Terminal Block BOX 10

O = Not required
Y = Required

Sheath O.D. BOX 5

D = .063" ±.001 **P** = 2.0 mm ±.03
F = .125" ±.002 **Q** = 3.0 mm ±.03
G = .188" ±.002 **R** = 4.5 mm ±.05
H = .250" +.003/- .002 **S** = 6.0 mm +.07/- .05
J = .313" +.003/- .002
K = .375" +.003/- .002

Special Requirements BOX 11

X = Specify
0 = None

⚠ WARNING: Cancer and Reproductive Harm - www.P65Warnings.ca.gov.

(800) 323-6859 • Email: sales@tempco.com



Style MTA7 Connection Head with 1/2" NPT Pipe Nipple

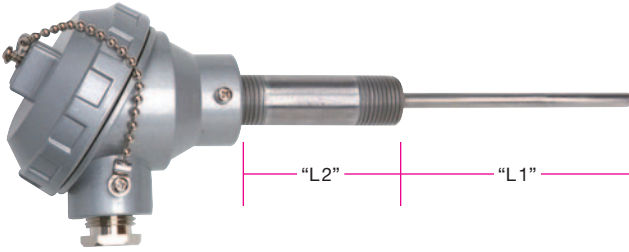

Design Features

- * Tempco's connection heads are gasketed to seal against moisture, dust and corrosive or hostile atmospheres.
- * Screw covers are attached to body with a plated chain.
- * Covers have lugs for tightening or loosening with a screwdriver or wrench.
- * Available in single (2-wire) or duplex (4-wire).
- * Tempco's connection heads are available in die cast aluminum, Bakelite and cast iron in a variety of sizes from miniature for confined areas to the large universal head designed for heavy process and industrial applications. See sensor accessories on pages 14-98 through 14-100 for complete information.
- * Pipe nipple is galvanized steel.

Ordering Information

Thermocouples are offered with the options listed in the worksheet below. Create an ordering code by filling in the boxes with the appropriate number and/or letter designation for your requirements, and a part number will be assigned.

Ordering Code:

MTA7 -

Calibration Code BOX 1

ANSI Standard Tolerances **J K E T N R S B**
 Special Tolerances **3 4 5 6 7**

Junction BOX 8

	Grounded	Ungrounded	Exposed
Single	G	U	E
Dual, common	4	5	6
Dual, isolated	-	7	8

Number of Conductors BOX 2

2 = Single (Standard)
4 = Duplex

Connection Head BOX 9

A = Standard Size Aluminum **S** = Stainless Steel
B = Medium Size Aluminum **F** = Standard Bakelite
C = Miniature Aluminum **P** = Polypropylene (FDA Approved)
H = Standard Cast Iron

Note: Conduit connection for A, F, H & S is 1/2" (3/4" is available); for B & C is 3/8"; and for P is 3/4" NPT. For overall dimensions see pages 14-98 through 14-100.

Insulation BOX 3

M = 96% min. MgO (Standard)
H = 99.4% min. MgO

Sheath Material BOX 4

A = Alloy 600
B = 304 SS
C = 316 SS

"L2" 1/2" NPT Nipple Length BOX 10

Whole inches **00** to **99**
 For lengths over 99 in. consult TEMPCO.
 Standard Lengths **S1** = 1", **S2** = 2-1/2", **S3** = 5-1/2"

Sheath O.D. BOX 5

F = .125" ±.002	Q = 3.0 mm ±.03
G = .188" ±.002	R = 4.5 mm ±.05
H = .250" +.003/- .002	S = 6.0 mm +.07/- .05
J = .313" +.003/- .002	
K = .375" +.003/- .002	

Spring-Loaded Terminal Block BOX 11

O = Not required
Y = Required

Sheath Length "L1" BOX 6

Whole inches **01** to **99**
 For lengths over 99 in. consult TEMPCO.

Sheath Length "L1" BOX 7

Fractional inches
0 = 0" **3** = 3/8" **6** = 3/4"
1 = 1/8" **4** = 1/2" **7** = 7/8"
2 = 1/4" **5** = 5/8"

Special Requirements BOX 12

X = Specify
0 = None

⚠ WARNING: Cancer and Reproductive Harm - www.P65Warnings.ca.gov.

Style MTA8 Connection Head with 1/2" NPT Nipple, Union, Nipple

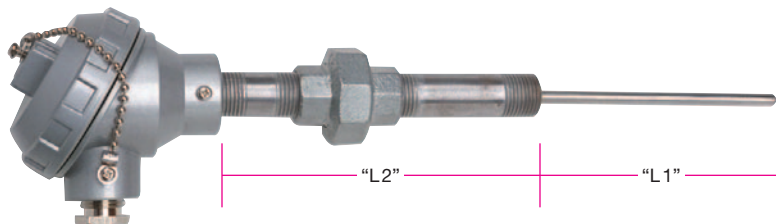

Design Features

- * Tempco's connection heads are gasketed to seal against moisture, dust and corrosive or hostile atmospheres.
- * Screw covers are attached to body with a plated chain.
- * Covers have lugs for tightening or loosening with a screwdriver or wrench.
- * Available in single (2-wire) or duplex (4-wire).
- * Tempco's connection heads are available in die cast aluminum, Bakelite and cast iron in a variety of sizes from miniature for confined areas to the large universal head designed for heavy process and industrial applications. See sensor accessories on pages 14-98 through 14-100 for complete information.
- * Nipple-Union-Nipple is galvanized steel.

Ordering Information

Thermocouples are offered with the options listed in the worksheet below. Create an ordering code by filling in the boxes with the appropriate number and/or letter designation for your requirements, and a part number will be assigned.

Ordering Code:

MTA8 - 1 2 3 4 5 6 7 8 9 10 11 12

Calibration Code BOX 1

ANSI Standard Tolerances **J K E T N R S B**
 Special Tolerances **3 4 5 6 7**

Junction BOX 8

	Grounded	Ungrounded	Exposed
Single	G	U	E
Dual, common	4	5	6
Dual, isolated	—	7	8

Number of Conductors BOX 2

2 = Single (Standard)
4 = Duplex

Connection Head BOX 9

A = Standard Size Aluminum **S** = Stainless Steel
B = Medium Size Aluminum **F** = Standard Bakelite
C = Miniature Aluminum **P** = Polypropylene (FDA Approved)
H = Standard Cast Iron

Note: Conduit connection for A, F, H & S is 1/2" (3/4" is available); for B & C is 3/8"; and for P is 3/4" NPT.
 For overall dimensions see pages 14-98 through 14-100.

Insulation BOX 3

M = 96% min. MgO (Standard)
H = 99.4% min. MgO

Sheath Material BOX 4

A = Alloy 600
B = 304 SS
C = 316 SS

"L2" Dimension (in.) BOX 10

Nipple, Union, Nipple
 Whole inches **03** to **99**
 Standard Lengths **S1** = 3-1/2", **S2** = 6-1/2", **S3** = 12-1/2"

Sheath O.D. BOX 5

F = .125" ±.002 **Q** = 3.0 mm ±.03
G = .188" ±.002 **R** = 4.5 mm ±.05
H = .250" +.003/-.002 **S** = 6.0 mm +.07/-.05
J = .313" +.003/-.002
K = .375" +.003/-.002

Spring-Loaded Terminal Block BOX 11

O = Not required
Y = Required

Sheath Length "L1" BOX 6

Whole inches
01 to **99**
 For lengths over 99 in. consult TEMPCO.

Sheath Length "L1" BOX 7

Fractional inches
0 = 0" **3** = 3/8" **6** = 3/4"
1 = 1/8" **4** = 1/2" **7** = 7/8"
2 = 1/4" **5** = 5/8"

Special Requirements BOX 12

X = Specify
0 = None

⚠ WARNING: Cancer and Reproductive Harm - www.P65Warnings.ca.gov.

Temperature Sensing

MI Cable Thermocouple Assemblies



Style MTA9 Handheld Probe

Bakelite Handle

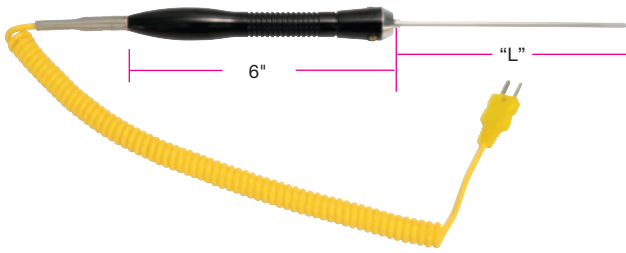

Teflon® Handle

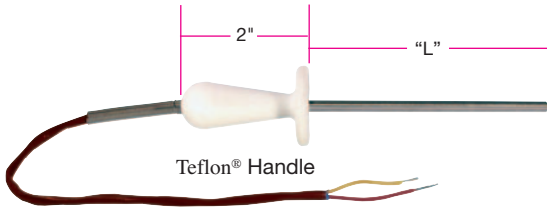

Design Features

- * Coil cord lengths are available only in 1 ft. (5 ft. extended) and 2 ft. (10 ft. extended).
- * Coil cord construction is good to 221°F (105°C).
- * Fiberglass lead construction is good to 900°F (482°C).
- * Teflon® insulated lead construction is good to 392°F (200°C).

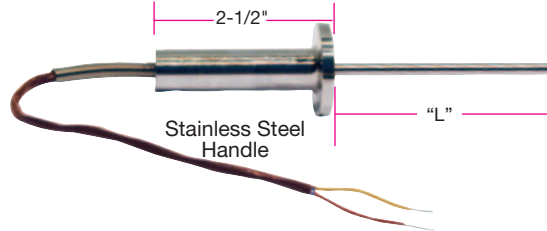

Ordering Information

Thermocouples are offered with the options listed in the worksheet below. Create an ordering code by filling in the boxes with the appropriate number and/or letter designation for your requirements, and a part number will be assigned.

Ordering Code:

MTA9 -

Calibration Code BOX 1

ANSI Standard Tolerances **J K E T N**
 Special Tolerances **3 4 5 6 7**

Sheath Length "L" BOX 6

Whole inches
01 to 99
 For lengths over 99 in. consult TEMPCO.

Lead Wire Construction BOX 11

		Overbraided	Flex Armor
Coil Cord	C	—	—
Fiberglass	S	B	A
Teflon®	T	D	F

Note: Coil cord insulation is PVC/Polyurethane with a temperature rating of 221°F (105°C).

Number of Conductors BOX 2

2 = Single
4 = Duplex

Sheath Length "L" BOX 7

Fractional inches
0 = 0" **3** = 3/8" **6** = 3/4"
1 = 1/8" **4** = 1/2" **7** = 7/8"
2 = 1/4" **5** = 5/8"

Lead Wire Termination BOX 12

P = Standard Male Plug
J = Standard Female Jack
K = Std. Plug with Mating Jack
D = Mini Male Plug
E = Mini Female Jack
F = Mini Plug with Mating Jack
B = Std.— 2-1/2" Split Leads
S = Leads with Spade Lugs
C = 2-1/2" Split with BX connector and Spade Lugs

Insulation BOX 3

M = 96% min. MgO (Standard)
H = 99.4% min. MgO

Junction BOX 8

	Grounded	Ungrounded	Exposed
Single	G	U	E
Dual, common	4	5	6
Dual, isolated	—	7	8

Sheath Material BOX 4

A = Alloy 600
B = 304 SS
C = 316 SS

Tip BOX 9

R = Round Tip
D = Drill Point
F = Flat Tip
O = Exposed Junction

Handle Type BOX 13

1 = Stainless Steel
2 = Teflon® 500°F (260°C)
3 = Bakelite 400°F (204°C)

Sheath O.D. BOX 5

F = .125" ±.002
G = .188" ±.002
H = .250" +.003/-.002

Lead Wire Length BOX 10

In inches **012 to 999**
For Coil Cords Enter 060 or 120

Special Requirements BOX 14

X = Specify
0 = None

⚠ WARNING: Cancer and Reproductive Harm - www.P65Warnings.ca.gov.

Thermocouples with Transmitter and Connection Head

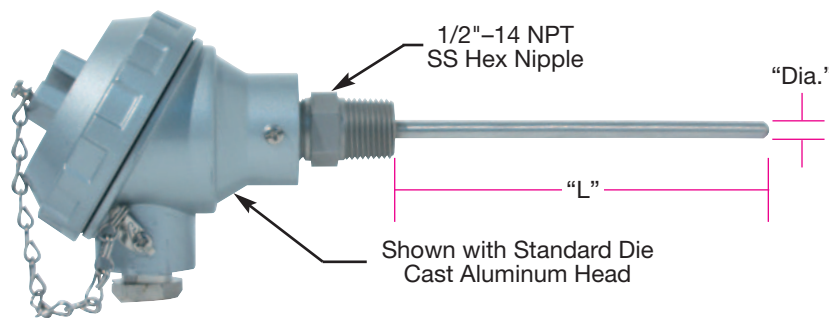

Design Features

- * 4-20mA Programmable Linear Output Transmitter
- * Available with Spring-Loaded Sheath
- * For field programming of the temperature transmitter see Part Number ETM90006 on page 12-45
- * Transmitter Accuracy of $\pm 0.2\%$ of temperature span
- * 1/2" NPT Process Connection

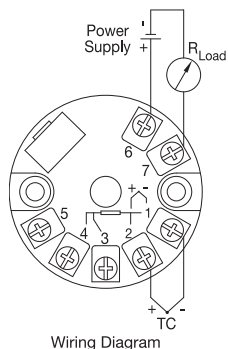

Transmitter Ambient Temperature Range:
 -40° to +185°F (-40° to +85°C)
 Refer to page 12-44 for complete details.



EMT10001



EMT20001

See Connection Head Box 9 below.

Refer to page 12-50 for complete Indicator specifications.

Ordering Information

Thermocouples are offered with the options listed in the worksheet below. Create an ordering code by filling in the boxes with the appropriate number and/or letter designation for your requirements, and a part number will be assigned.

Ordering Code:

TTM -

Calibration Code BOX 1

ANSI Standard Tolerances: **J K E T**
 Special Tolerances: **3 4 5 6**

Junction Type BOX 7

Grounded: **G** Ungrounded: **U** Exposed: **E**

Insulation BOX 2

M = 96% min. MgO (Standard)
H = 99.4% min. MgO

Transmitter Type BOX 8 (Enter Code Below)

<input type="text"/>	<input type="text"/>	<input type="text"/>	<input type="text"/>	<input type="text"/>	<input type="text"/>	<input type="text"/>	<input type="text"/>
			Temperature low range		Temperature high range		Unit °F / °C
			1 = Non-isolated (Standard)		2 = Isolated		

Sheath Material BOX 3

A = Alloy 600 **C** = 316 SS
B = 304 SS

Connection Head BOX 9

A = Standard Aluminum **S** = Stainless Steel
B = Medium Size Aluminum **L** = Aluminum Head with LCD Indicator (EMT10001)
H = Standard Cast Iron
P = Polypropylene Head (FDA Approved) **M** = Heavy Duty Aluminum Head with LCD Indicator (EMT20001)

Note: Conduit connection for A, H & S is 1/2", for B is 3/8" NPT, for P is 3/4" NPT. For overall dimensions see pages 14-98 through 14-100.

Sheath O.D. BOX 4

F = .125" **H** = .250"
G = .188"

Spring-Loaded BOX 10

Y = Spring-Loaded
0 = Not Required

Special Requirements BOX 11

X = Specify
0 = None

Sheath Length "L" BOX 5

Whole inches
01 to 99
 For lengths over 99 in. consult TEMPCO.

Sheath Length "L" BOX 6

Fractional inches
0 = 0" **2** = 1/4" **4** = 1/2" **6** = 3/4"
1 = 1/8" **3** = 3/8" **5** = 5/8" **7** = 7/8"

⚠ WARNING: Cancer and Reproductive Harm - www.P65Warnings.ca.gov.

Series TCM Multipoint Thermocouple Assemblies

Multipoint Thermocouples are used in a broad range of processes and installations to monitor the temperature in multiple positions or elevations. These sensors are used in a variety of applications such as Petroleum, Chemical Processing, Furnaces, Storage Tanks and Air Flow Ducts.

These sensors are made-to-order to meet the requirements of the specific application. The styles depicted below are the most common constructions. Consult Tempco for other sizes and construction methods. To order, simply fill out the specification sheet on page 14-31.

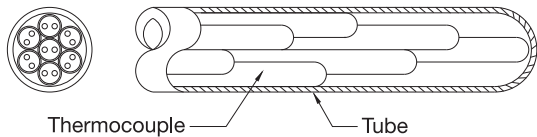

Style 1 – Standard Miniature Style Assembly

This Multipoint Assembly uses numerous individual mineral insulated thermocouple elements contained in a tube. Individual thermocouples are made with the largest possible Mineral Insulated Cable in order to maximize contact with Protection Tube.

Tube OD	Maximum Number of Points
.125"	13
.188"	20
.250"	20
.312"	20
.375"	20
.500"	20

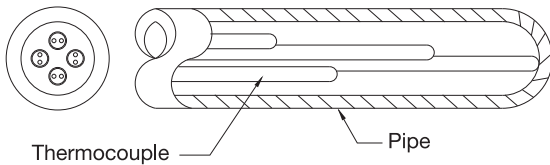

Style 2 – Free-Hanging Assembly In A Pipe

This Heavy Duty Multipoint Assembly uses several individual Mineral Insulated Thermocouple Elements contained in a Standard Protection Pipe. Thermocouple bundles are replaceable.

Pipe Size	Maximum Number of Points
1/2" NPT SCH. 40	12
3/4" NPT SCH. 40	20
1" NPT SCH. 40	20

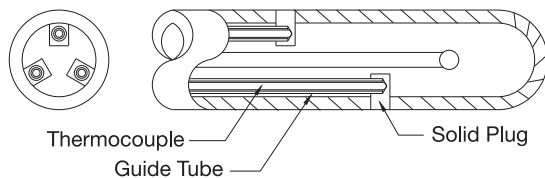

Style 3 – Protection Pipe With Guide Tubes

This Multipoint Assembly is mostly used in the Petrochemical Industry. Guide Tubes are positioned at specific locations and enable the replacement of individual sensors in the field. This Multipoint Style is ideal in high temperature and pressure applications and provides a quick thermal response.

Pipe Size	Maximum Number of Points
1/2" NPT SCH. 40	10
3/4" NPT SCH. 40	20
1" NPT SCH. 40	20

Multipoint Assemblies with Protection Tube

Style 1 Shown with Lead Wire Extension

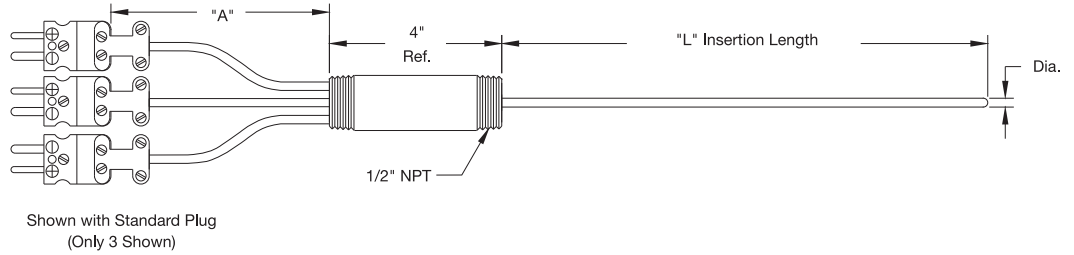

Style 1 Shown with Standard Die Cast T/C Head
(3 Points Maximum)

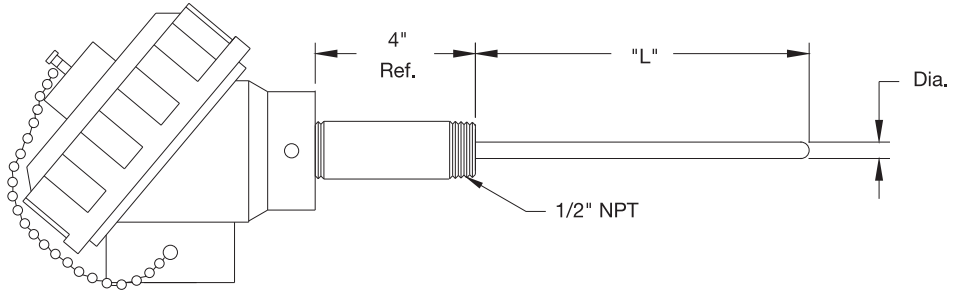

Style 1 Shown with Nema 4 Junction Box

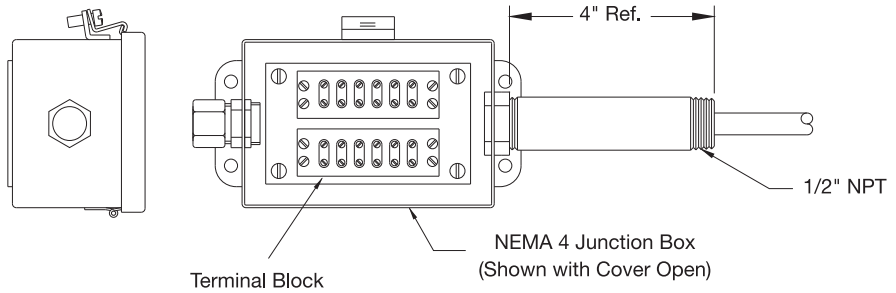

Style 1 Shown with Jack Panel Junction Box

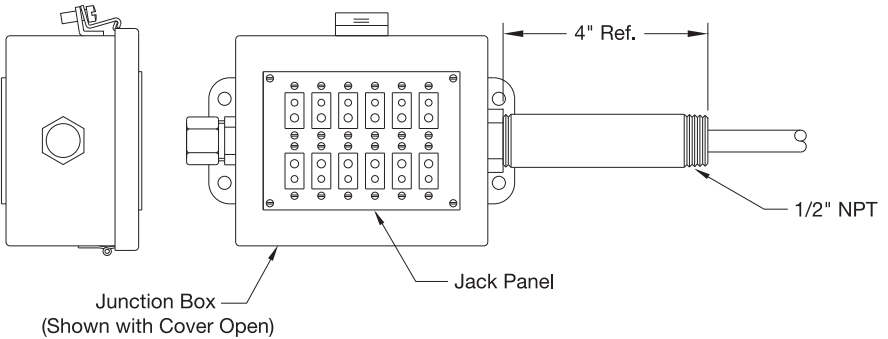

CONTINUED

Heavy Duty Multipoint Assemblies with Pipe as Protection Tube

Style 2 Shown with Union, Threaded Process Connection and Nema 4 Junction Box

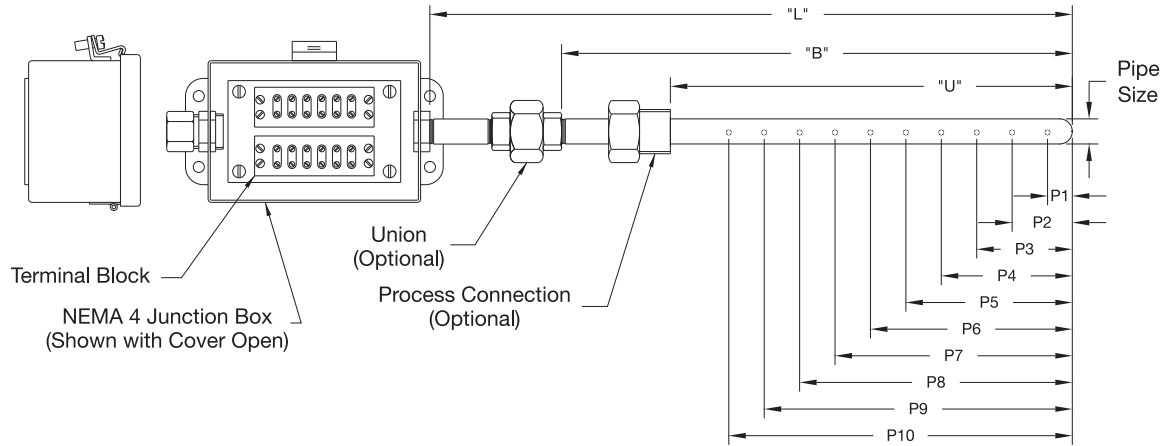

Style 2 Shown with Union, Flange and Jack Panel Junction Box

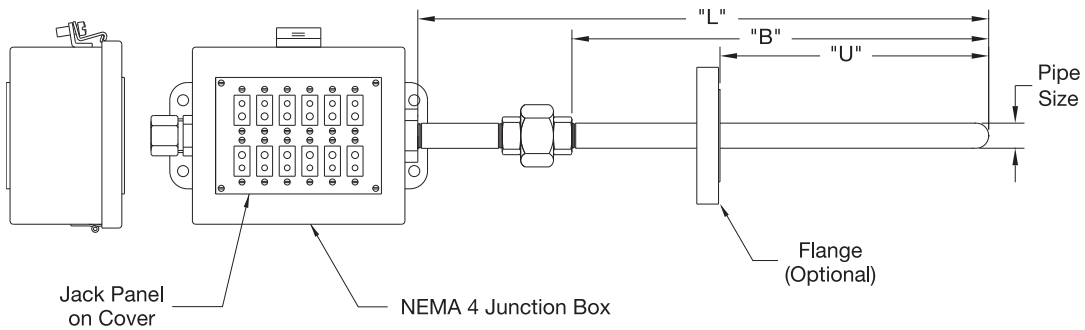



Ordering Information for Multipoint Assemblies

Please supply the following information by filling in the boxes as required.

Calibration = _____

J, K, E, T, N

Other (Specify)

Junction = _____

Grounded Or Ungrounded

Protection Tube Dia.= _____

Tube Sizes: .125", .188", .25", .312", .375", .500"

PIPE Sizes (SCH. 40): 1/2" NPT, 3/4" NPT, 1" NPT

Other (specify)

Are Guide Tubes Required? _____ (Style 3) See Page 14-28

Protection Tube Length = _____

"L" Dimension (in inches)

Protection Tube Material = _____

Tube Materials: 304SS, 316SS, Inconel 600

Pipe Materials: 304/304L SS, 316/316L SS, 446SS, Inconel 600

Other (specify)

Point Locations (in inches) See Page 14-30

List As Many As Needed

P1=____ P11=____

P2=____ P12=____

P3=____ P13=____

P4=____ P14=____

P5=____ P15=____

P6=____ P16=____

P7=____ P17=____

P8=____ P18=____

P9=____ P19=____

P10=____ P20=____

Union (option)

If Required, Specify "B" Dim. = _____

"B" Dim. is the length below the union

(Enter 0 if not required)

Material: _____

Rating: _____

(150 lbs. Galvanized Steel is standard)

Flange or Threaded Process Connection (option)

If Required, Specify "U" Dim. = _____

"U" Dim. is the length below flange or thread

Flange or Process Thread: _____

(Enter 0 if not required)

Size: _____

Material: _____

Rating: _____

Face Type (Flange): _____

Termination = _____

NEMA 4 Junction Box With Terminal Block

Jack Panel Junction Box

Std. Aluminum T/C Head (3 Points Max.)

Other (specify)

Lead Wire Extension (if Required)

Length ("A" Dim.) = _____ (in Inches)

(Enter 0 If Not Required)

Insulation = _____

Fiberglass

Fiberglass w/ SS Overbraid

Teflon® (400°F Max.)

Termination = _____

Standard Plug or Jack

Mini Plug or Jack

Spade Lugs or with BX Connector

2-1/2" Stripped Ends

Other (specify)

Describe any Pertinent Information or Special Requirements:

Industrial Process Thermocouples



Tempco manufactures many styles of industrial thermocouple assemblies for a wide range of industries, from petrochemical to textile applications, where one or more protection tubes may be necessary to protect the thermocouple.

Metal Protecting Tube Assemblies

Thermowell Assemblies

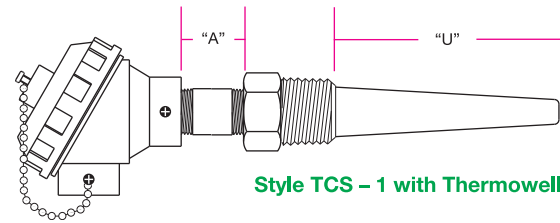
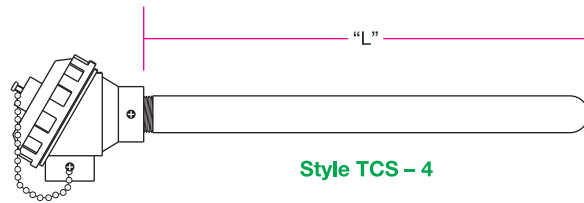

Thermocouple Head, Nipple, Thermowell

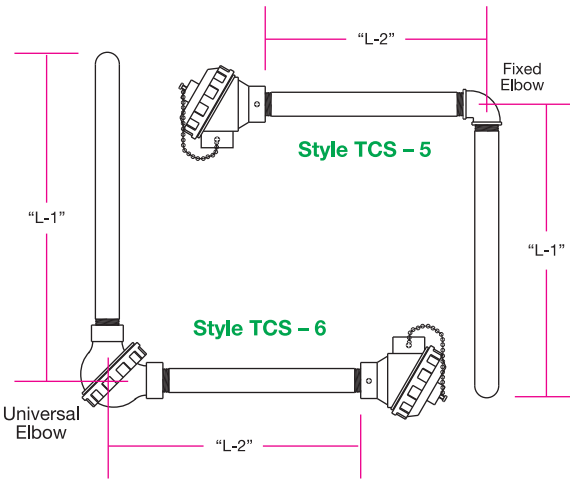

Thermocouple Head, Metal Protecting Tube

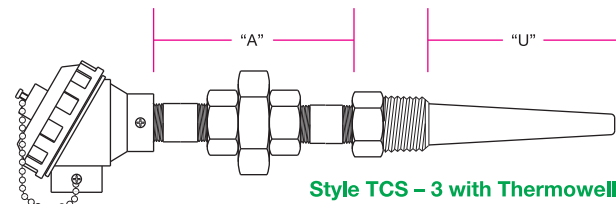

Thermocouple Head, Nipple, Union, Nipple, Thermowell

Ceramic Tube Assemblies

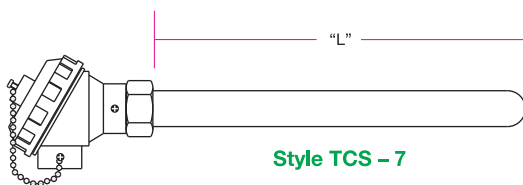

Thermocouple Head, Fixed Bushing, Ceramic Tube

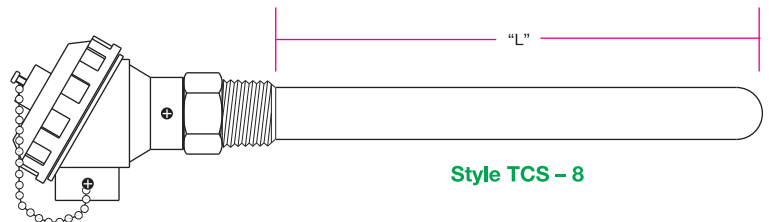

Thermocouple Head, Ceramic Tube

Thermocouples for Thermowells and Protection Tubes

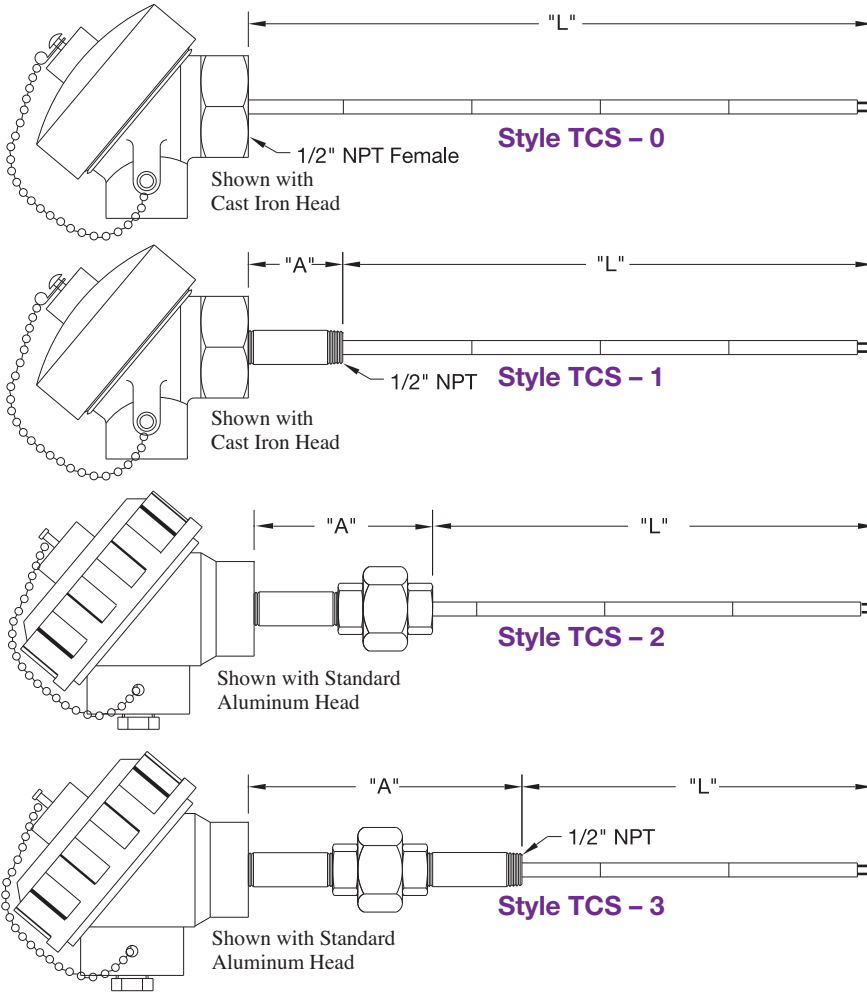

Design Features

- * Ceramic Insulator to Insulate Wires
- * Galvanized 1/2" Pipe Nipple & Union
- * Cast Iron or Aluminum Head
- * Used with protection tubes and thermowells shown on pages 14-76 through 14-86

Ordering Information

Thermocouples are offered with the options listed in the worksheet below. Create an ordering code by filling in the boxes with the appropriate number and/or letter designation for your requirements, and a part number will be assigned.

Ordering Code: **TCS** -

Style BOX 1

- 0** = Plain
- 1** = with Nipple
- 2** = with Nipple and Union
- 3** = with Nipple, Union and Nipple

Calibration Code BOX 2

- J** = Type J
- K** = Type K
- X** = Other (Specify)

Wire Gauge and Insulator Size BOX 3

- B** = 20 ga. (.172" x .118" insulator)
- C** = 14 ga. (.375" x .217" insulator)
- D** = 8 ga. (.437" x .250" insulator)
- X** = Other (Specify)

"L" Dimension BOX 4

Whole inches
00 to 99

"A" Dimension (TCS -1, TCS -2 & TCS -3 only) BOX 5
01 to 99 inches or use Codes below for standard length
Enter **00** for TCS - 0 Style

TCS1	TCS2	TCS3
S1 = 1"	S1 = 2-1/2"	S1 = 3-1/2"
S2 = 2-1/2"	S2 = 4"	S2 = 6-1/2"
S3 = 5-1/2"	S3 = 7"	S3 = 12-1/2"

Connection Head BOX 6

A = Standard Size Aluminum
H = Standard Cast Iron
S = Stainless Steel
Note: All have 1/2" conduit connection (3/4" available).
For overall dimensions see pages 14-98 through 14-100.

Special Requirements BOX 7

X = Specify
0 = None

WARNING: Cancer and Reproductive Harm - www.P65Warnings.ca.gov.

Metal Protection Tube Thermocouple Assemblies

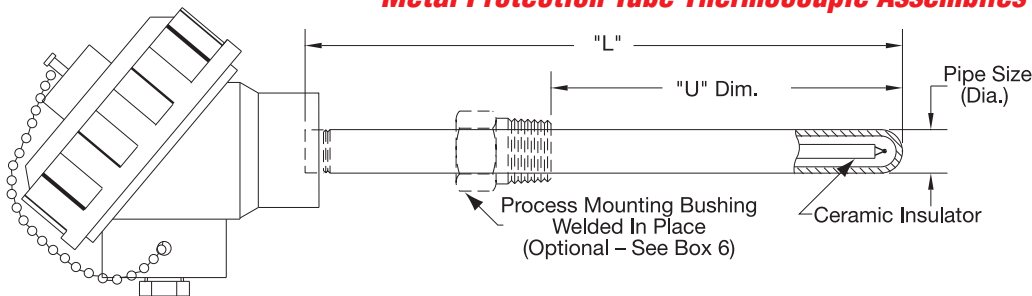

Shown with Standard Die Cast Aluminum Head

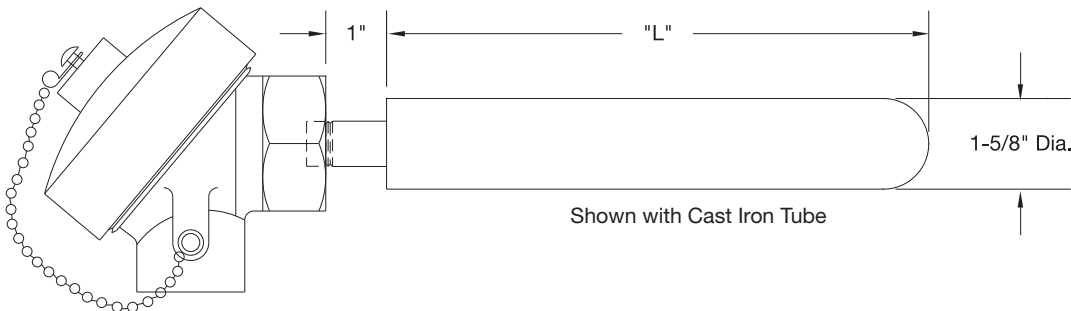

Shown with Cast Iron Head

Ordering Information

Thermocouples are offered with the options listed in the worksheet below. Create an ordering code by filling in the boxes with the appropriate number and/or letter designation for your requirements, and a part number will be assigned.

Design Features

- * Widely used in high temperature industrial process heating applications such as furnaces, ovens; and petrochemical and textile applications up to 2200°F (1204°C)
- * Pipe size protection tubes made with schedule 40 pipe in various steel and nickel alloys
- * Optional process mounting bushing welded on protection tube
- * Thermocouple heads are available in aluminum, cast iron or stainless steel. Explosion proof heads are also available in aluminum or stainless steel

Ordering Code: **TCS4** -

Pipe Size Sch. 40 BOX 1

H = 1/2" Pipe (.84" OD x .62" ID)
M = 3/4" Pipe (1.05" OD x .82" ID)
N = 1" Pipe (1.31" OD x 1.05" ID)
R = 1-5/8" OD x 7/8" ID (Cast Iron Only)
X = Other (Specify)

Wire Gauge BOX 4

B = 20 ga.
C = 14 ga.
D = 8 ga.
X = Other (Specify)

"U" Dimension BOX 7

Whole inches 01 to 99
 Enter 00 for cast iron tube or if no bushing required

Sheath Material BOX 2

1 = Carbon Steel (Black Pipe)
2 = 304 SS
3 = 316 SS
4 = 446 SS
5 = Cast Iron (1-5/8" OD x 7/8" ID Only)
6 = Alloy 601
X = Other (Specify)

"L" Dimension BOX 5

Whole inches 12 to 96
 (in 6-inch increments)
 Cast Iron is available in limited lengths.

Connection Head BOX 8

A = Standard Size Aluminum
H = Standard Cast Iron
S = Stainless Steel
Note: All have 1/2" conduit connection (3/4" available).
 For overall dimensions see pages 14-98 through 14-100.

Calibration Code BOX 3

J = Type J
K = Type K
X = Other (Specify)

Process Mounting Bushing BOX 6

0 = No Bushing Required
 Enter 0 for Cast Iron Tube
M = 3/4" NPT (For 1/2" pipe only)
N = 1" NPT (For 1/2 and 3/4" pipe only)
P = 1-1/4" NPT
X = Other (Specify)

Special Requirements BOX 9

X = Specify
0 = None

WARNING: Cancer and Reproductive Harm - www.P65Warnings.ca.gov.

Metal and Silicon Carbide Protection Tube Thermocouple Assemblies

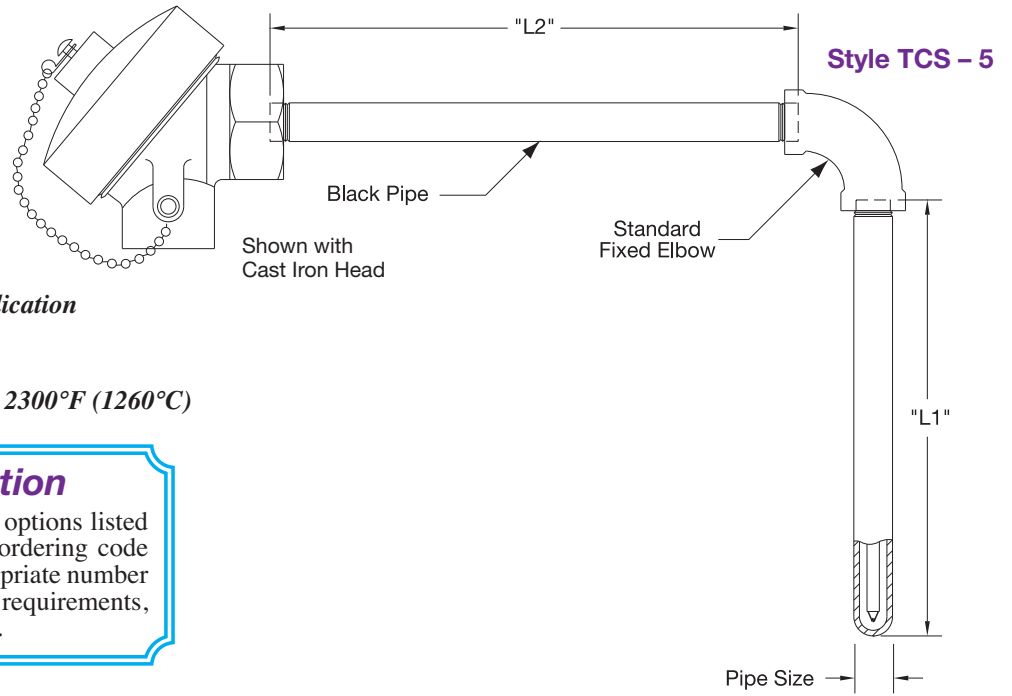

Design Features

- * Right Angle for Over-the-Side Application
- * Cast Iron or Aluminum Head
- * Available with Metal Pipe or Silicon Carbide (Carbon Bonded) 2300°F (1260°C)

Ordering Information

Thermocouples are offered with the options listed in the worksheet below. Create an ordering code by filling in the boxes with the appropriate number and/or letter designation for your requirements, and a part number will be assigned.

Ordering Code: **TCS** -

Elbow Type BOX 1

5 = Standard Fixed Elbow

Wire Gauge BOX 5

B = 20 ga.
C = 14 ga.
D = 8 ga.

Pipe and Tube Size BOX 2

H = 1/2" Pipe (.84" OD x .62" ID)
M = 3/4" Pipe (1.05" OD x .82" ID)
N = 1" Pipe (1.31" OD x 1.05" ID)
R = 1-5/8" OD x 7/8" ID (Cast Iron Only)
S = 2-1/16" OD (Silicon Carbide Only)
X = Other (Specify)

"L1" Dimension BOX 6

Whole inches 12 to 96
(in 6-inch increments)
Silicone Carbide and Cast Iron are available in limited lengths.

Sheath Material BOX 3

1 = Carbon Steel (Black Pipe)
2 = 304 SS
3 = 316 SS
4 = 446 SS
5 = Cast Iron (1-5/8" OD x 7/8" ID Only)
6 = Alloy 601
7 = Silicone Carbide (2-1/16" OD Only)
X = Other (Specify)

"L2" Dimension BOX 7

Whole inches 12 to 96 (in 6-inch increments)

Connection Head BOX 8

A = Standard Size Aluminum
H = Standard Cast Iron
S = Stainless Steel
Note: All have 1/2" conduit connection (3/4" available).
For overall dimensions see pages 14-98 through 14-100.

Calibration Code BOX 4

J = Type J
K = Type K
X = Other (Specify)

Special Requirements BOX 9

X = Specify
0 = None

⚠ WARNING: Cancer and Reproductive Harm - www.P65Warnings.ca.gov.

(800) 323-6859 • Email: sales@tempco.com

Ceramic and Silicon Carbide Protection Tube Thermocouple Assemblies

Design Features

- * Ceramic Insulator to Insulate Wires
- * Choice of Alumina 3450°F (1900°C), Mullite 3100°F (1700°C), Hexoloy SA (sintered silicon carbide) 3000°F (1650°C) or Silicon Carbide (carbon bonded) 2300°F (1260°C)
- * With or Without Threaded Process Mounting Bushing
- * Available with Double Protection Tube

Style TCS - 7

Without Threaded Process Connection

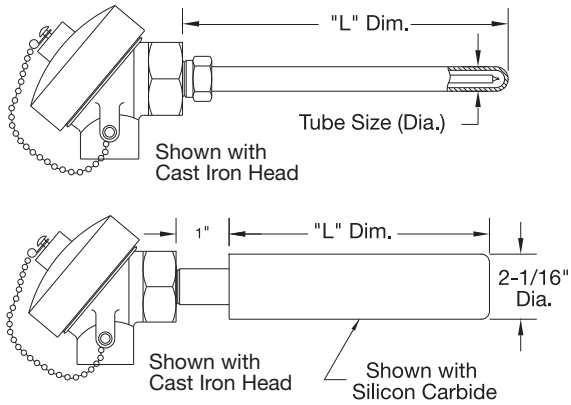

Style TCS - 8

With Threaded Process Connection

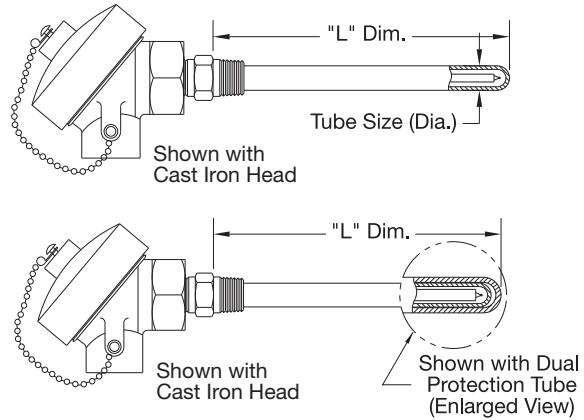

Ordering Code: TCS -

Style BOX 1

- 7 = Plain
- 8 = w/Pipe Thread Process Connection

Sheath Material BOX 2

- A = Alumina
- H = Hexoloy SA (sintered silicone carbide)
- M = Mullite
- S = Silicon Carbide (carbon bonded)
- X = Other (Specify)

Tube & Fitting Size BOX 3

(Style TCS - 7 has no process pipe thread)

- 1 = 3/8" OD (1/4" ID) — 1/2" NPT Thread for Style TCS-8 (available in Alumina, Mullite or Hexoloy SA only)
- 2 = 5/8" OD (3/8" ID) — 1/2" NPT Thread for Style TCS-8 (available in Hexoloy SA only)
- 3 = 11/16" OD (7/16" ID) — 3/4" NPT Thread for Style TCS-8 (available in Alumina or Mullite only)
- 4 = 3/4" OD (1/2" ID) — 3/4" NPT Thread for Style TCS-8 (available in Hexoloy SA only)
- 5 = 2-1/16" OD (Style TCS-7) (available in carbon bonded silicone carbide only)
- X = Other (Specify)

Calibration Code BOX 4

- J = Type J R = Type R
- K = Type K B = Type B
- S = Type S

Wire Gauge BOX 5

- A = 24 ga. (Type S, R and B) D = 8 ga.
- B = 20 ga. X = Other (Specify)
- C = 14 ga.

"L" Dimension BOX 6

Whole inches **12 to 48**
in 6-inch increments
For lengths over 48 in. consult TEMPCO.

Threaded Bushing Material

- BOX 7
- S = Stainless Steel
 - B = Brass
 - Enter 0 for TCS-7

Protection Tube BOX 8

- 1 = Single Protection Tube (Std.)
- 2 = Double Protection Tube

Connection Head BOX 9

- A = Standard Size Aluminum
- H = Standard Cast Iron
- S = Stainless Steel
- Note: All have 1/2" conduit connection (3/4" available). For overall dimensions see pages 14-98 through 14-100.

Special Requirements BOX 10

- 0 = None
- X = Specify

Ordering Information

Thermocouples are offered with the options listed in the worksheet. Create an ordering code by filling in the boxes with the appropriate number and/or letter designation for your requirements, and a part number will be assigned.

Base Metal — Bare and Fiberglass or Ceramic Insulated Thermocouple Wire

Tempco offers general purpose thermocouple elements in ANSI Type J and K. The general purpose elements are available with

a twisted and welded or butt-welded junction. Available in 8 ga., 14 ga. and 20 ga. with standard calibration tolerances.

Style B — Bare Thermocouple Wire



Twisted and Welded Junction



Butt-Welded Junction

Style F — Thermocouple Wire with Fiberglass Sleaving



Twisted and Welded Junction



Butt-Welded Junction

Style O — Thermocouple Wire with 2-Hole Oval Insulator



Twisted and Welded Junction



Butt-Welded Junction

• 8 ga. insulator P/N COR-120-105

• 14 ga. insulator P/N COR-120-104

• 20 ga. insulator P/N COR-120-106

* See Page 14-96 for Insulator Dimensions. *

Style R — Thermocouple Wire with 2-Hole Round Insulator



Twisted and Welded Junction



Butt-Welded Junction

• 8 ga. insulator P/N COR-127-102

• 14 ga. insulator P/N COR-126-102

• 20 ga. insulator P/N COR-125-102

* See Page 14-96 for Insulator Dimensions. *

Ordering Information

Base Metal Thermocouple Element Styles B, F, O and R are offered with the options listed below. Create an ordering code by filling in the boxes with the appropriate number and/or letter designation for your requirements, and a part number will be assigned.

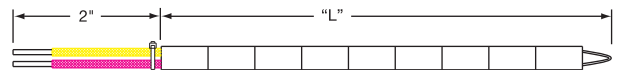

Ordering Code: **TCB** -

-

Design Style B, F, O or R

Calibration ANSI Type K or J

Wire Gauge Size 8 ga. (08), 14 or 20

Junction **W** = Twisted and Welded
B = Butt-Welded

Length "L" in whole inches — 06-99

⚠ WARNING: Cancer and Reproductive Harm - www.P65Warnings.ca.gov.

(800) 323-6859 • Email: sales@tempco.com

Industrial Thermocouples

Base Metal Thermocouples

Design Features

- * Base Metal Thermocouple Elements insulated with ceramic insulators
- * Can be used to replace thermocouple inserts in industrial thermocouple assemblies

Style D – Dual Element (Available in 14 ga. and 20 ga. only)

Dual set of thermocouple wires with 4-hole round alumina insulators

- 14 ga. insulator P/N COR-128-102
- 20 ga. insulator P/N COR-128-101

* See Page 14-96 for Insulator Dimensions.*



Ordering Information

Base Metal Thermocouple Element Style D is offered with the options listed below. Create an ordering code by filling in the boxes with the appropriate number and/or letter designation for your requirements, and a part number will be assigned.

Ordering Code: **TCB** -



Design Style

Calibration ANSI Type K or J

Wire Gauge Size 14 or 20

Butt-Welded Junction

- 1 = Common
- 2 = 2 separate junctions

Length "L" in whole inches — 06-99"

Style A – Angle Element

Angle thermocouple wires with 2-hole round ceramic insulators.

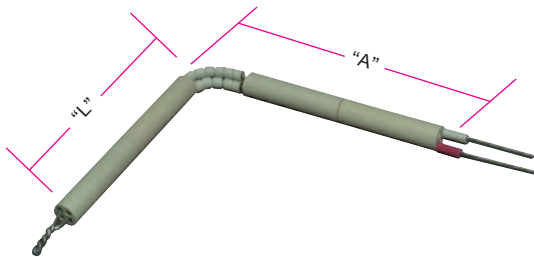

Twisted and Welded Junction

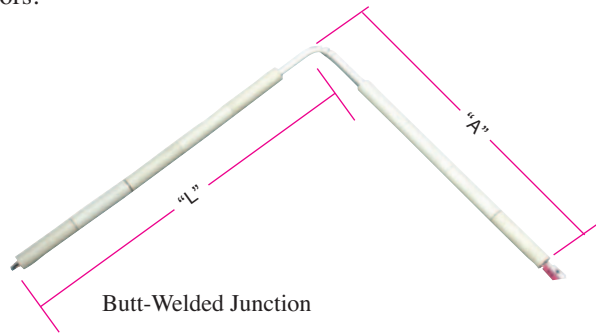

Butt-Welded Junction

- 8 ga. insulator P/N COR-120-105

- 14 ga. insulator P/N COR-120-104

- 20 ga. insulator P/N COR-120-106

* See Page 14-96 for Insulator Dimensions.*

Ordering Information

Base Metal Thermocouple Element Style A is offered with the options listed below. Create an ordering code by filling in the boxes with the appropriate number and/or letter designation for your requirements, and a part number will be assigned.

Ordering Code: **TCB** -



Design Style

Calibration ANSI Type K or J

Wire Gauge Size 8 ga. (08), 14 or 20

Length "L" in whole inches — 3" min.

Junction **W** = Twisted and Welded
B = Butt-Welded

Length "A" in whole inches — 3" min.

⚠ WARNING: Cancer and Reproductive Harm - www.P65Warnings.ca.gov.

Noble Metal Thermocouples

Design Features

* Noble Metal Thermocouple Elements ANSI Type R and S are provided in accordance with ITS90, and ANSI Type B is provided in accordance with IPTS-68.

* Alumina insulators are recommended with noble metal thermocouples. All noble metal elements have a butt-welded junction & are available in 20 ga. (.032"), 24 ga. (.020") and 30 ga. (.010").

Style NB – Noble Bare Thermocouple Wire

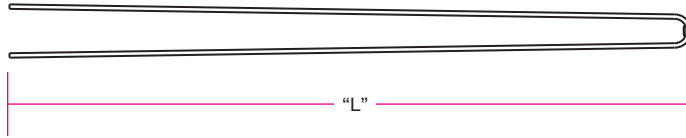

Ordering Information

Noble Metal Thermocouple Element Style NB is offered with the options listed below. Create an ordering code by filling in the boxes with the appropriate number and/or letter designation for your requirements, and a part number will be assigned.

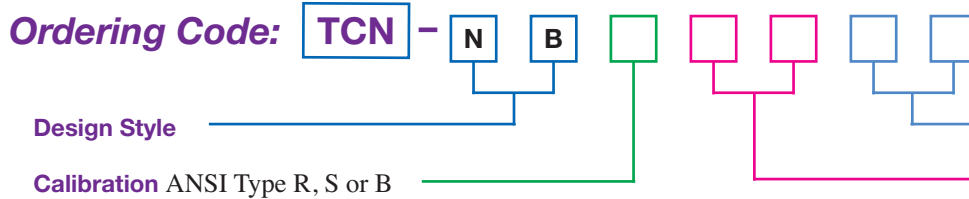

Style NZ – Noble Thermocouple Wire with 2-Hole Round Alumina Insulator

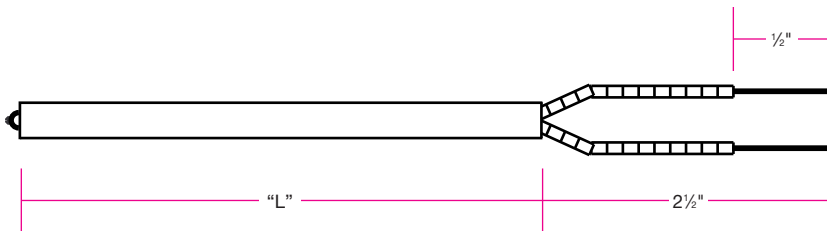

Ordering Information

Noble Metal Thermocouple Element with 2-hole Alumina insulator Style NZ is offered with the options listed below. Create an ordering code by filling in the boxes with the appropriate number and/or letter designation for your requirements, and a part number will be assigned.

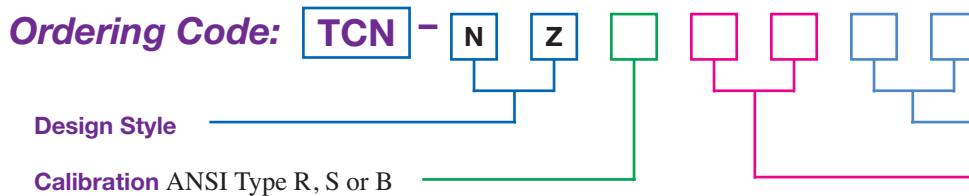

- 30 ga. Insulator P/N COR-124-105 and P/N CER-103-101 Ceramic Beads
- 24 ga. Insulator P/N COR-124-104 and P/N CER-103-101 Ceramic Beads
- 20 ga. Insulator P/N COR-124-106 and P/N CER-103-101 Ceramic Beads

* See Page 14-96 for Insulator Dimensions *

For Metal and Ceramic Protection Tubes
see pages 14-85 and 14-86.

⚠ WARNING: Cancer and Reproductive Harm - www.P65Warnings.ca.gov.

(800) 323-6859 • Email: sales@tempco.com

OEM Replacement Thermocouples

Direct Replacement Thermocouples

- * All the following thermocouples are manufactured with the highest quality materials and workmanship.
- * The thermocouple wire is stranded (for flexibility) ANSI Type J thermocouple grade, with ANSI color-coded fiberglass insulation (White=Positive, Red=Negative).
- * All hot junctions are grounded. Spade lugs where required are insulated and accept a No. 6 stud.

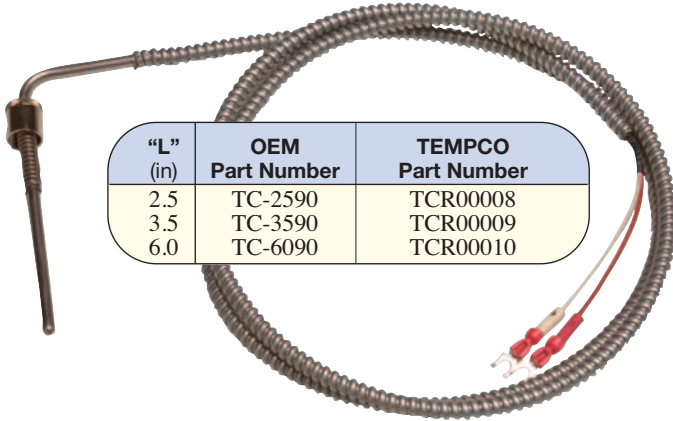

"L" (in)	OEM Part Number	TEMPCO Part Number
2.5	TC-2590	TCR00008
3.5	TC-3590	TCR00009
6.0	TC-6090	TCR00010

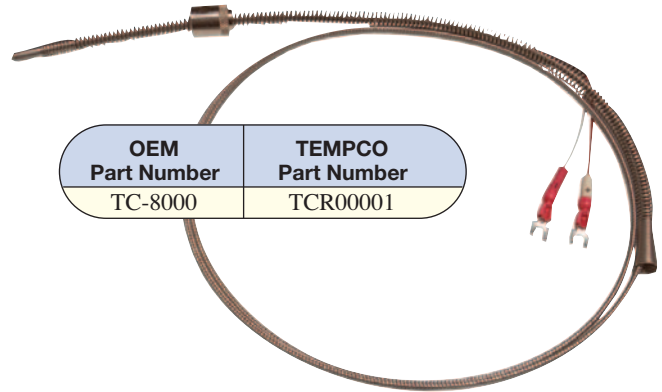
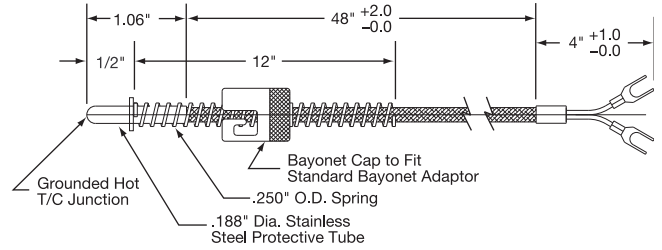

OEM Part Number	TEMPCO Part Number
TC-8000	TCR00001

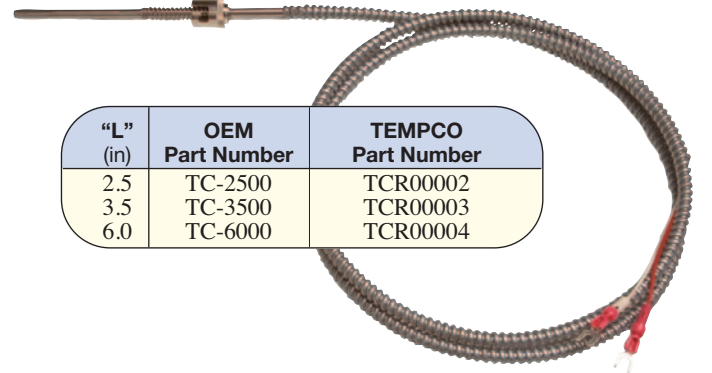
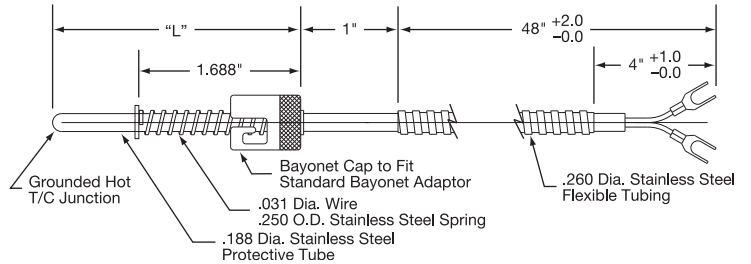
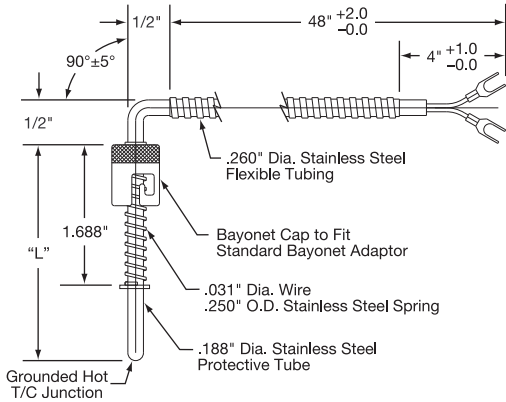

"L" (in)	OEM Part Number	TEMPCO Part Number
2.5	TC-2500	TCR00002
3.5	TC-3500	TCR00003
6.0	TC-6000	TCR00004

All Items Available from Stock

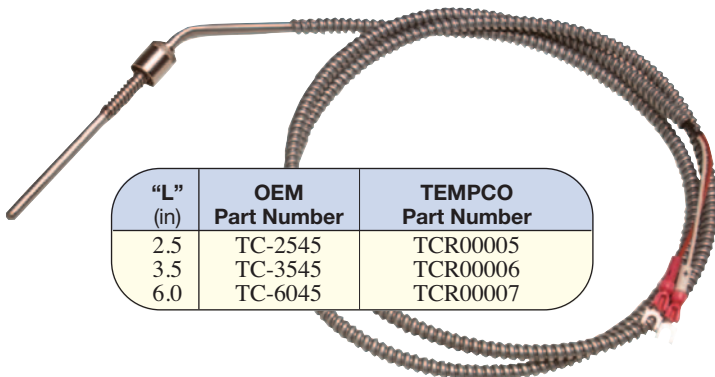

"L" (in)	OEM Part Number	TEMPCO Part Number
2.5	TC-2545	TCR00005
3.5	TC-3545	TCR00006
6.0	TC-6045	TCR00007

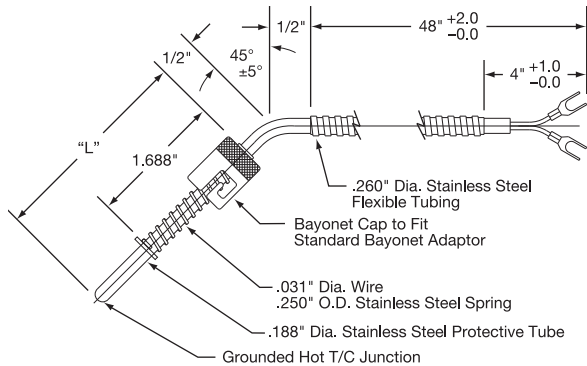

OEM Replacement Thermocouples

Spring Adjustable Thermocouples with 3-pin Male Plug

- * *Ungrounded Type J Thermocouple*
- * *12" Long Compression Spring*
- * *Grounded Stainless Steel Braided Shield*
- * *900°F (482°C) Max. Operation*
- * *Used with the Bayonet Adapters on page 14-87*

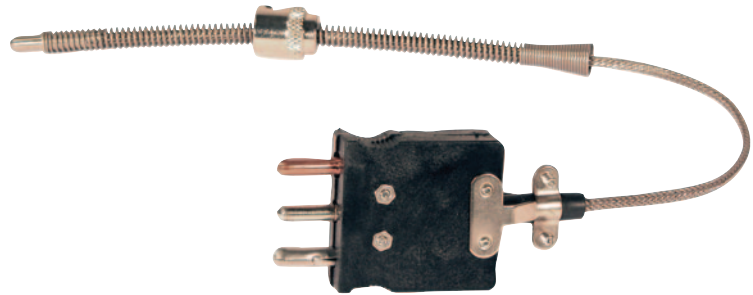

Part Number	Length (inches)
TCP18001	24
TCP18002	36
TCP18003	48
TCP18004	60
TCP18005	72
TCP18006	84
TCP18007	96
TCP18008	108
TCP18009	120
TCP18010	132
TCP18011	144

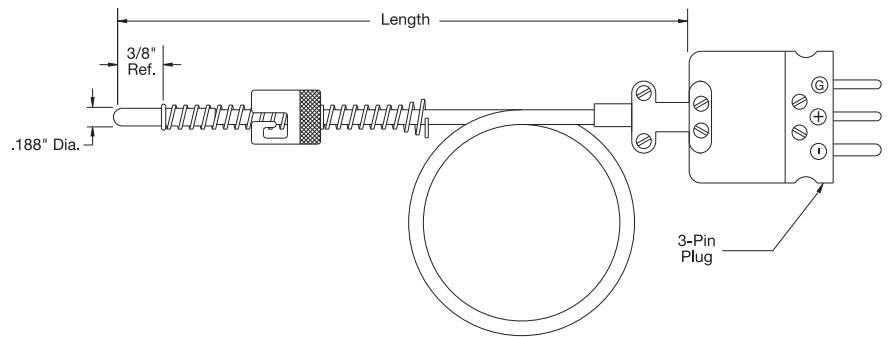

Armor Cable Adjustable Thermocouples with 3-pin Male Plug

- * *Ungrounded Type J Thermocouple*
- * *Grounded Stainless Steel Armor Cable*
- * *900°F (482°C) Max. Operation*
- * *Used with the Bayonet Adapters on page 14-87*



Part Number	Length (inches)
TCP28001	12
TCP28002	24
TCP28003	36
TCP28004	48
TCP28005	60
TCP28006	72
TCP28007	84
TCP28008	96
TCP28009	108
TCP28010	120
TCP28011	132
TCP28012	144

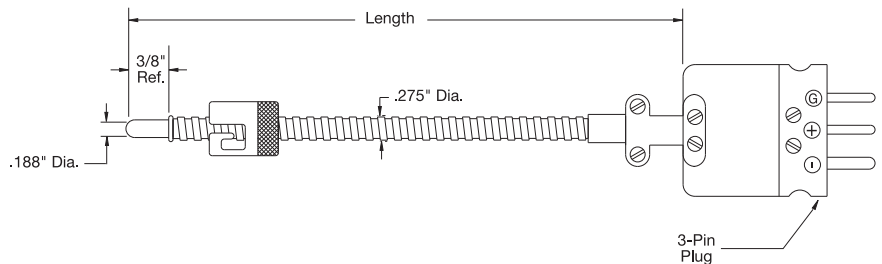

OEM Replacement Thermocouples (Type J)

Spring-Loaded Bayonet Style Thermocouples with 3-pin Male Plug

- * Ungrounded Type J Thermocouple
- * Grounded Stainless Steel Braided Shield
- * 900°F (482°C) Max. Operation
- * Used with the Bayonet Adapters on page 14-87

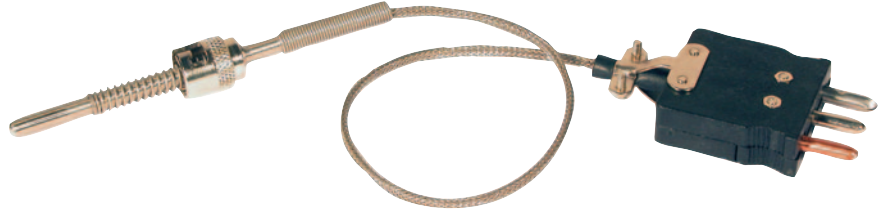

Part Number	Length (inches)
TCP38101	12
TCP38102	24
TCP38103	36
TCP38104	48
TCP38105	60
TCP38106	72
TCP38107	84
TCP38108	96
TCP38109	108
TCP38110	120

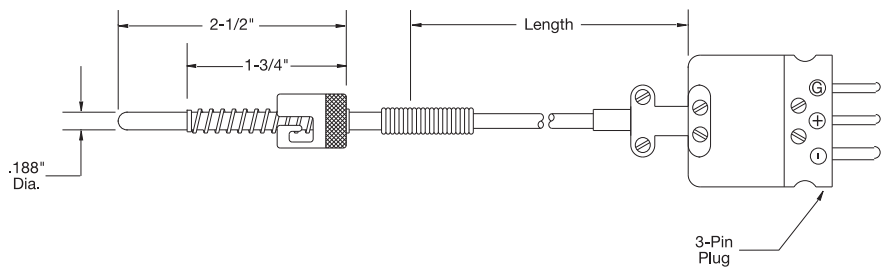

Nozzle Style Thermocouples with 3-pin Male Plug

- * Ungrounded Type J Thermocouple
- * Rotatable 1/4-28 UNF Threaded Tip with Strain Relief Spring
- * Grounded Stainless Steel Braided Shield
- * 900°F (482°C) Max. Operation



Part Number	Length (inches)
TNW81001	12
TNW81002	24
TNW81003	36
TNW81004	48
TNW81005	60
TNW81006	72
TNW81007	84
TNW81008	96
TNW81009	108
TNW81010	120
TNW81011	132
TNW81012	144
TNW81013	156
TNW81014	168
TNW81015	180
TNW81016	192

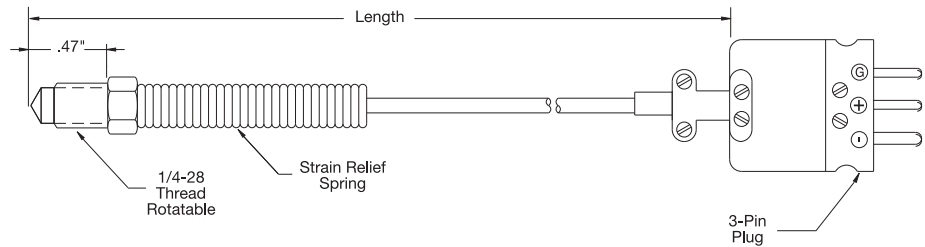

OEM Replacement Thermocouples (Type J)

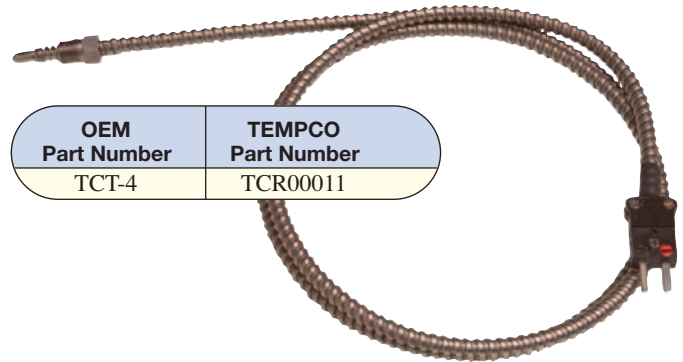
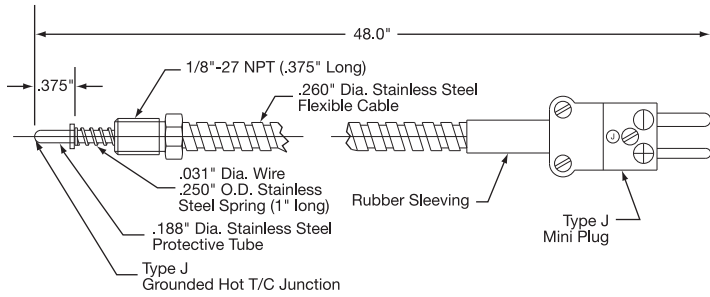

OEM Part Number	TEMPCO Part Number
TCT-4	TCR00011

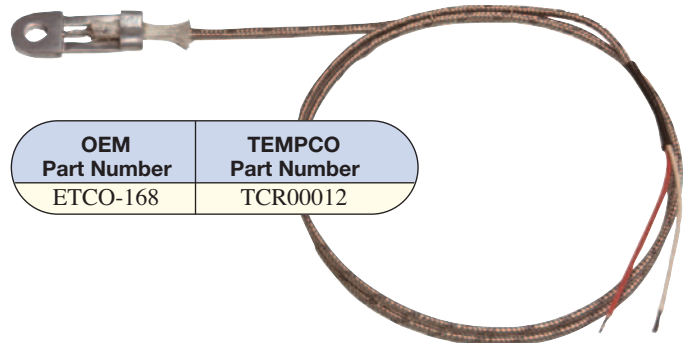
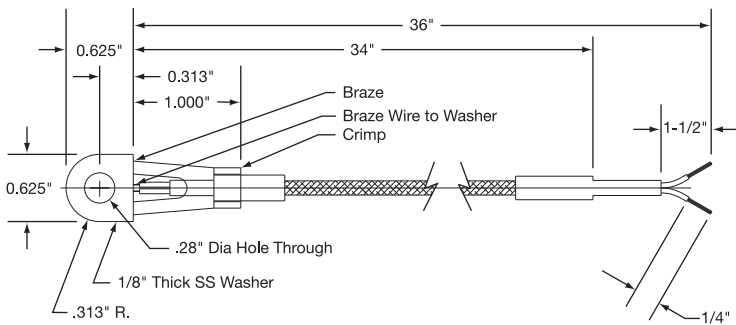

OEM Part Number	TEMPCO Part Number
ETCO-168	TCR00012

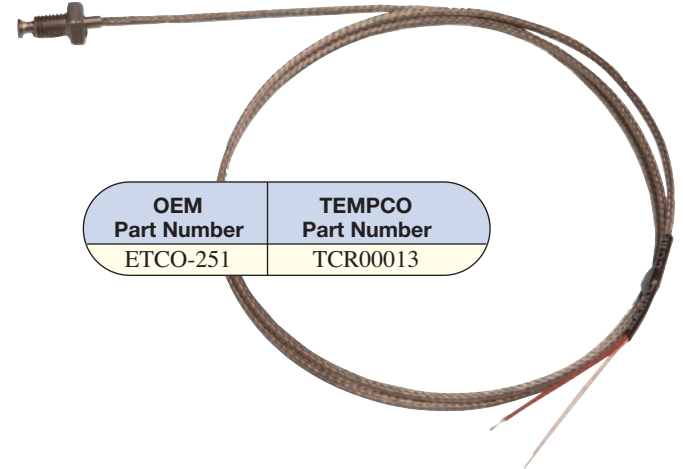
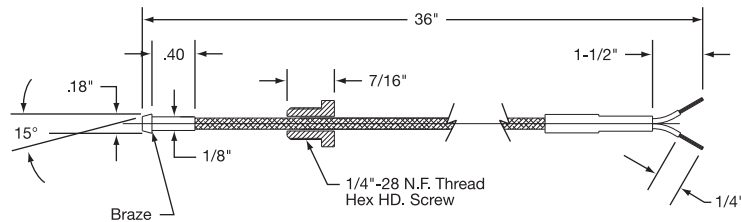

OEM Part Number	TEMPCO Part Number
ETCO-251	TCR00013

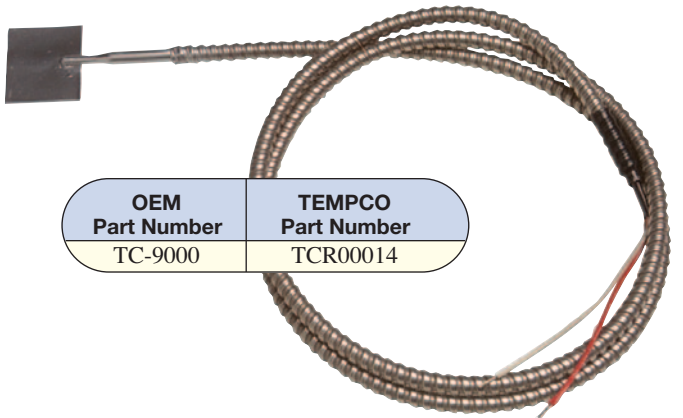
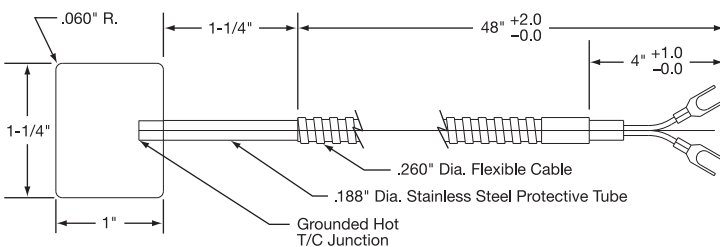

OEM Part Number	TEMPCO Part Number
TC-9000	TCR00014

All Items Available from Stock

OEM Replacement Thermocouples (Type J)

Specialty Application

The following **Runnerless Mold Thermocouples** are manufactured using Tempco's high quality, mineral insulated thermocouple wire "Tempco-Pak." The Tempco-Pak is .062" diameter 304 stainless steel sheathed, MgO insulated, ANSI Type J thermocouple wire.



Notes: All hot junctions are grounded.

The lead wire is ANSI Type "J" thermocouple grade with ANSI color-coded fiberglass insulation and an additional high temperature outer fiberglass sleeve. The transition area (potting adapter) between the Tempco-Pak and lead wire is potted with high temperature cement rated to 900°F (482°C).

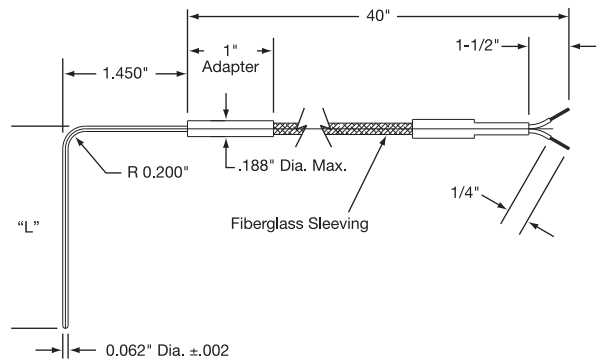
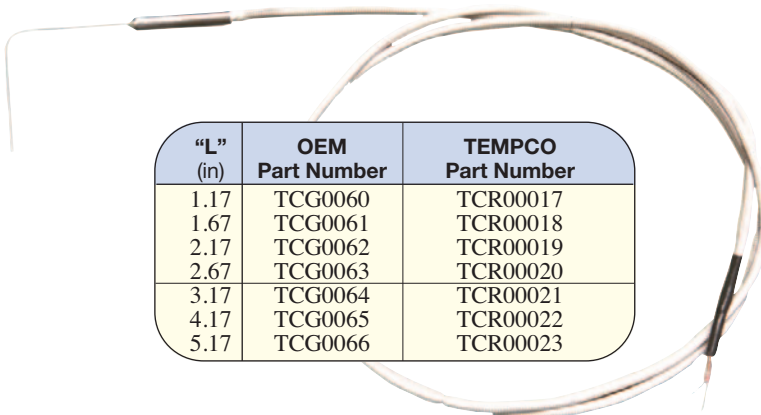
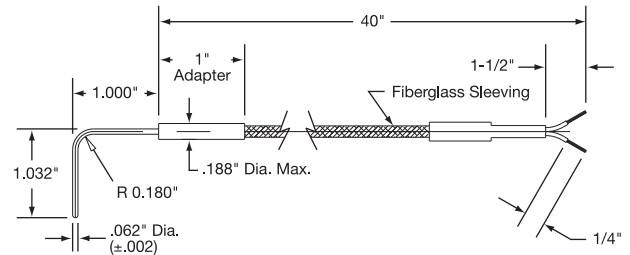
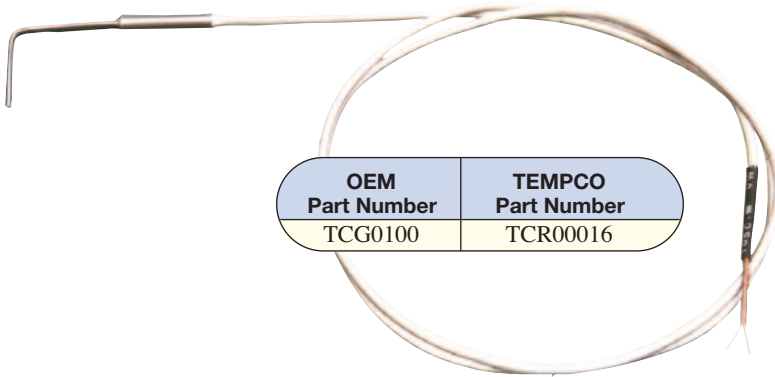
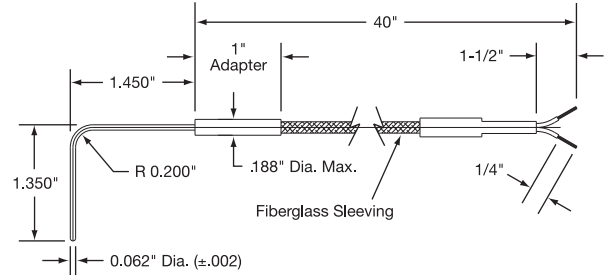
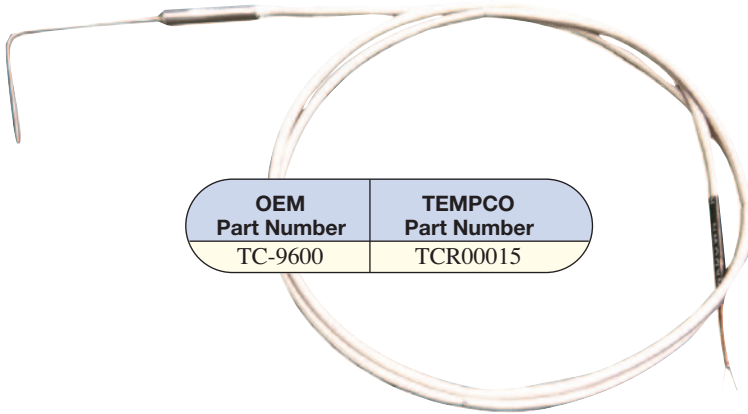

All Items Available from Stock

OEM Replacement Thermocouples (Type J)

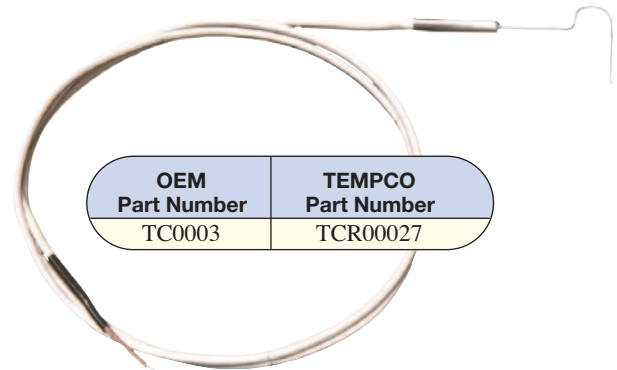
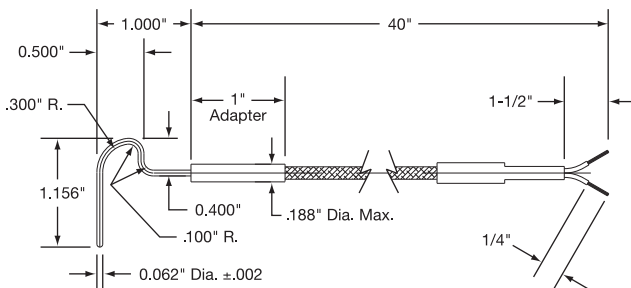
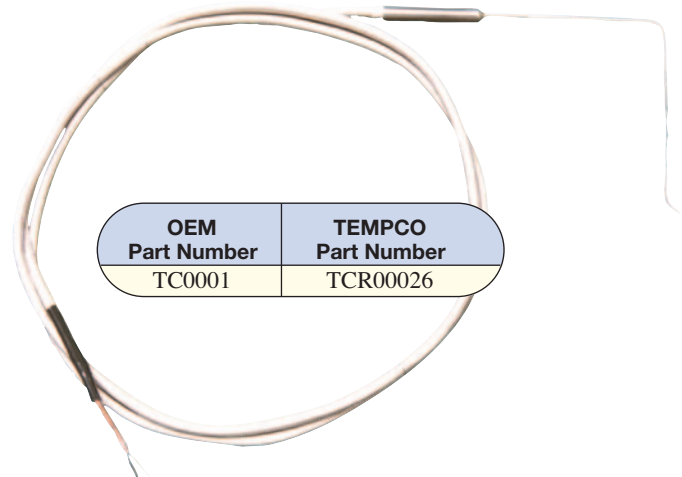
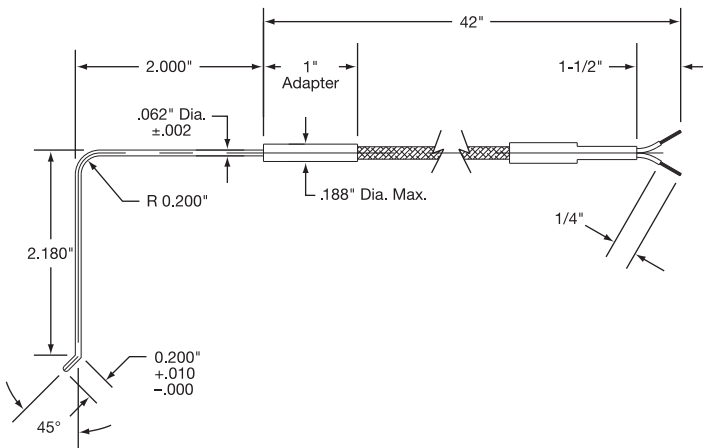
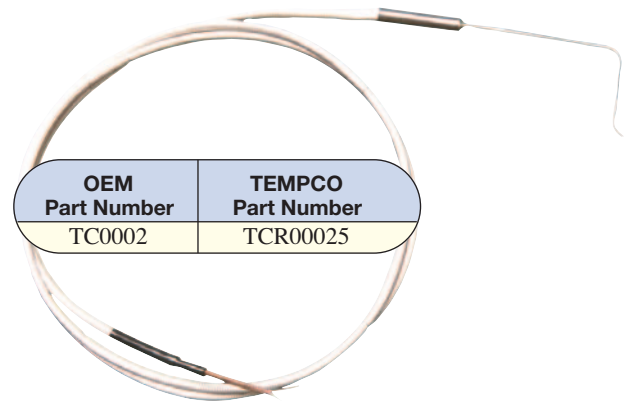
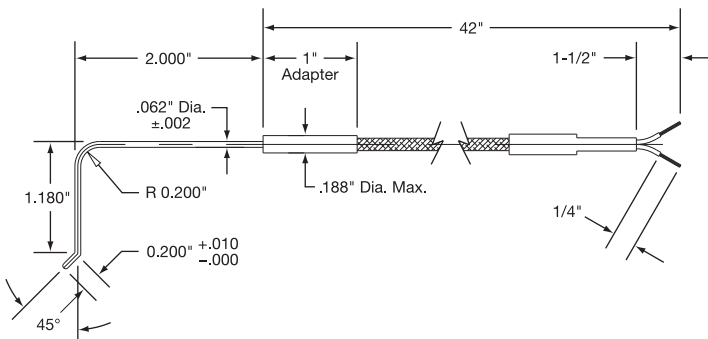
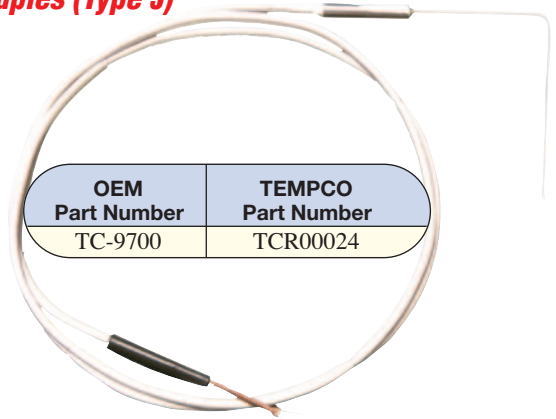
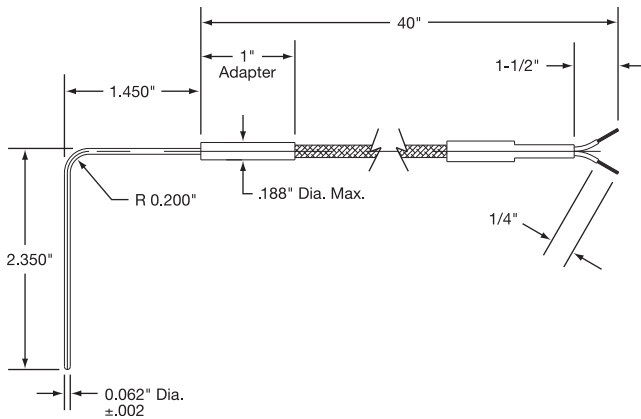

All Items Available from Stock

Comparing Three Types Of Temperature Sensors

RTDs VS. THERMOCOUPLES VS. THERMISTORS

RTDs

Resistance Temperature Detectors (RTDs) are temperature sensing devices consisting of a wire coil or deposited film of pure metal, usually platinum. The element's resistance increases with temperature in a known and repeatable manner. RTDs exhibit excellent accuracy over a wide temperature range, -200 to 650°C (-328 to 1202°F).

RTDs offer

Stability and repeatability: The platinum RTD is the primary interpolation instrument used by the National Institute of Standards and Technology from -260 degrees Celsius to 630 degrees Celsius. Precision RTDs can be manufactured with a stability of 0.0025 degrees Celsius per year. However, most industrial models drift less than 0.1 degrees Celsius per year.

Linearity: The platinum RTD produces a more linear curve than thermocouples or thermistors. The RTD's non-linearities can be corrected through proper design of resistive bridge networks.

Sensitivity: The voltage drop across an RTD provides a much larger output than a thermocouple. Since thermistors have a higher resistance than RTDs, the measuring current through them may be so low as to limit self-heating, making their voltage drop less than that of an RTD.

Standardization: RTDs are manufactured to industry standard curves, usually 100 ohm platinum to IEC 751, which makes them very interchangeable.

System Cost: RTDs usually offer a lower system cost than do thermocouples as they use ordinary copper extension leads and require no cold junction compensation.

Thermocouples

A thermocouple consists of two wires of dissimilar metals welded together into a junction. At the other end of the signal wires, usually as part of the input instrument, is another junction called the reference junction. Heating the sensing junction generates a thermoelectric potential (emf) proportional to the temperature difference between the two junctions. This millivolt-level emf, when compensated for the known temperature of the reference junction, indicates the temperature at the sensing tip. Published millivolt tables assume the reference junction is at 0 degrees Celsius.

Thermocouples are simple and familiar. Designing them into systems, however, is complicated by the need for special extension wires and reference junction compensation.

Thermocouple advantages include

Extremely high temperature capability: Thermocouples with a noble metal junction may be rated as high as 1700°C (3100°F).

Ruggedness: The inherent simplicity of thermocouples makes them resistant to shock and vibration.

Small size/fast response: A fine-wire thermocouple junction takes up little space and has low mass, making it suitable for point sensing and fast response.

Thermistors

Thermistors are resistive devices usually made of metal oxides formed into a bead and encapsulated in epoxy or glass. Thermistors show a large negative temperature coefficient. Their resistance drops dramatically and non-linearly with a temperature increase. A thermistor's sensitivity is many times that of an RTD, but its useful temperature range is limited.

Because of wide variations of performance and cost among thermistors, generalized advantages and disadvantages may not always apply.

Typical benefits are

Lower Sensor Cost: Basic thermistors are less costly than RTDs and thermocouples, but when assembled in protective sheaths or wells the price difference narrows. Thermistors with tighter interchangeability or extended temperature ranges often cost more than RTDs.

High Sensitivity: Resistance may be several thousand ohms, which provides a larger output than RTDs with the same measuring current, offsetting lead wire resistance problems. Caution must be taken to limit measuring current because thermistors are more susceptible to self-heating than are RTDs.

Point Sensing: A thermistor bead may be the size of a pinhead, allowing for small area sensing.

TEMPCO'S ACCU-OHM™ RTD

All of Tempco's Accu-Ohm RTDs comply with the following specifications:

IEC publication 751 issued by the International Electrotechnical Commission (dated 1983).

This is the widest international scope of any RTD standard. This publication sets the tolerance for platinum RTDs with a value of 100 ohms at 0°C with a temperature coefficient of resistance (TCR) of 0.00385 ohms/ohm/°C in one of two classes:

Class A: Plus or minus 0.06% at 0°C

Class B: Plus or minus 0.12% at 0°C

All Tempco RTDs meet class B; class A is optional.

DIN 43760 issued by Deutsches Institute für Normung (Germany), dated 1987. The platinum resistance curves are now covered under DIN IEC 751.

JIS 1604-1989 issued by the Japanese Standards Association (dated 1989).

The Platinum resistance curves are in accordance with IEC 751 but there is also a provision for TCR 0.003916 ohms/ohm/°C which can be supplied in most of Tempco's standard designs on special request.

BS 1904-1984 issued by the British Standard Institute (dated 1984). This specification is identical to IEC 751.

What is Temperature Coefficient of Resistance (TCR)?

Temperature coefficient differentiates between resistance/temperature curves of RTDs. It is also called ALPHA and may be specified in various ways by different manufacturers. Here TCR is the RTDs resistance change from 0 to 100°C, divided by the resistance at 0°C, divided by 100°C:

$$TCR (\Omega/\Omega/^\circ C) = \frac{R_{100^\circ C} - R_{0^\circ C}}{R_{0^\circ C} \times 100^\circ C}$$

Example: A platinum RTD measuring 100 Ω's at 0°C and 138.5 Ω's at 100°C has TCR 0.00385 Ω/Ω/°C

$$TCR = \frac{138.5 \Omega - 100 \Omega}{100 \Omega \times 100^\circ C} = 0.00385 \Omega/\Omega/^\circ C$$

Stated another way, TCR is the average resistance increase per degree of a hypothetical RTD measuring 1 ohm at 0°C.

The most common use of TCR is to distinguish between curves for platinum, which is available with TCRs ranging from 0.00375 to 0.003927. The highest TCR indicates the highest purity platinum, and is mandated by ITS-90 for standard platinum thermometers.

There are no technical advantages of one TCR versus another in practical industrial applications. 0.00385 platinum is the most popular worldwide standard and is available in both wire-wound and thin-film elements.

In most cases, all you need to know about TCR is that it must be properly matched when replacing RTDs or connecting them to instruments.

Interchangeability and Repeatability

Interchangeability and accuracy are commonly cited as the RTDs most distinguishing attributes. Because of the tight tolerances of the Class A and Class B, RTDs are quite interchangeable. Their accuracy is also very good because of the RTD's repeatability over the standard temperature scale from -260°C to 630°C. Ordinary industrial RTDs tend to show a drift of less than 0.1°C per year in normal use.

Because RTDs are exactly what the name implies (Resistance Temperature Detectors), a resistance type sensor, any resistance introduced by the addition of extension wires between the RTD and the control or measuring instrument will add to the readings. This added resistance is not constant since the extension wires, usually copper, change their resistance values with changing ambient temperature. Extension wire errors can be significant, particularly with small gauge wires or elements with low sensitivity. Fortunately most of these errors may be nearly canceled by using a three wire system.

The majority of RTDs in today's industry are 3- or 4-wire systems; the 2-wire lead system is the least efficient unless the leads are heavy gauge, very short, or both.

In 3- or 4-wire circuits, common leads, connected to the same end of the RTD element, are the same color.

Tolerances for 100Ω RTDs

Temperature (°C)	Tolerance			
	Class A		Class B	
	(± °C)	(± Ω)	(± °C)	(± Ω)
-200	0.55	0.24	1.3	0.56
-100	0.35	0.14	0.8	0.32
0	0.15	0.06	0.3	0.12
100	0.35	0.13	0.8	0.30
200	0.55	0.20	1.3	0.48
300	0.75	0.27	1.8	0.64
400	0.95	0.33	2.3	0.79
500	1.15	0.38	2.8	0.93
600	1.35	0.43	3.3	1.06
650	1.45	0.46	3.6	1.13
700	—	—	3.8	1.17
800	—	—	4.3	1.28
850	—	—	4.6	1.34

Tolerance Values as a Function of Temperature for 100Ω RTDs

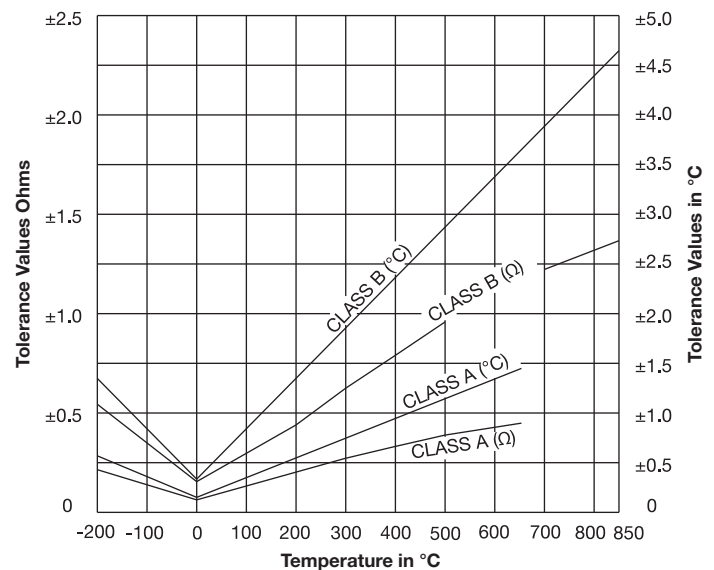

Wiring Diagrams

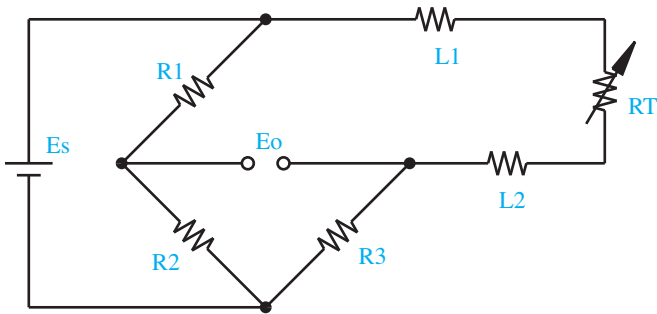

2-wire circuit

Shown is a 2-wire RTD connected to a typical Wheatstone bridge circuit. E_s is the supply voltage; E_o is the output voltage; R_1 , R_2 , and R_3 are fixed resistors; and RT is the RTD. In this uncompensated circuit, lead resistance L_1 and L_2 add directly to RT .

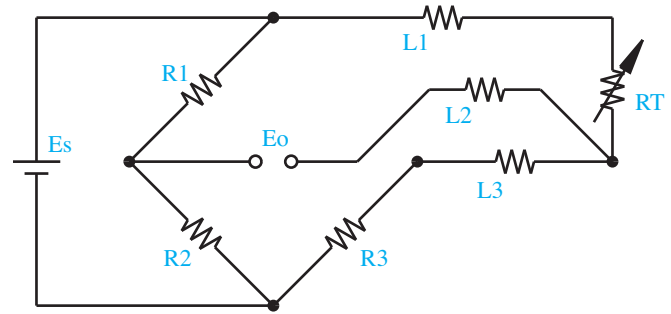

3-wire circuit

In this circuit there are three leads coming from the RTD instead of two. L_1 and L_3 carry the measuring current while L_2 acts only as a potential lead. No current flows through it while the bridge is in balance. Since L_1 and L_3 are in separate arms of the bridge, resistance is canceled. This circuit assumes high impedance at E_o and close matching of resistance between wires L_2 and L_3 . TEMPACO matches RTD leads within 5%. As a rule of thumb, 3-wire circuits can handle wire runs up to 100 feet.

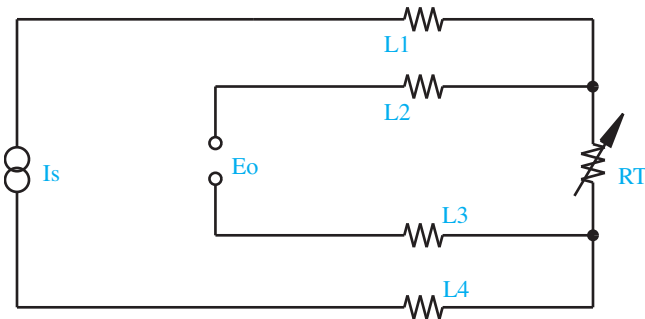

4-wire circuit

4-wire RTD circuits not only cancel lead wires but remove the effects of mismatched resistances such as contact points. A common version is the constant current circuit shown here. I_s drives a precise measuring current through L_1 and L_4 ; L_2 and L_3 measure the voltage drop across the RTD element. E_o must have high impedance to prevent current flow in the potential leads. 4-wire circuits may be usable over a longer distance than 3-wire, but you should consider using a transmitter in electrically noisy environments.

If necessary you can connect a 2-wire RTD to a 3-wire circuit or 4-wire circuit, as shown. As long as the junctions are near the RTD, as in a connection head, errors are negligible.

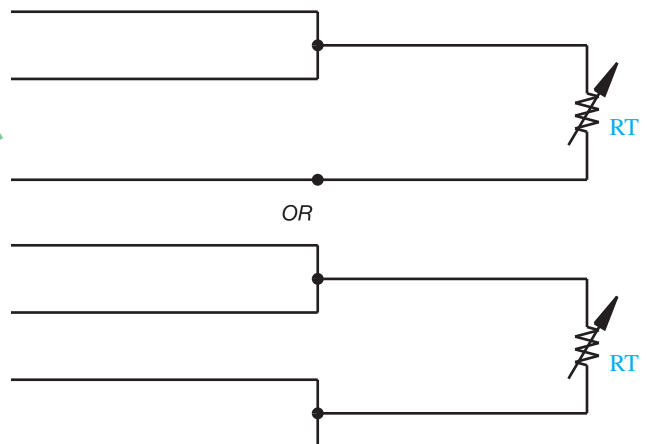

RTD Temperature vs. Resistance Table

100 Ohm RTD

DIN 43760 with Temperature Coefficient of .00385
JIS 1604-1989 with Temperature Coefficient of .00392

°C	DIN	JIS	°C	DIN	JIS	°F	DIN	JIS	°F	DIN	JIS
-100	60.26	59.54	290	208.48	210.45	-200	48.46	47.54	580	213.63	215.69
-90	64.30	63.66	300	212.05	214.08	-180	53.02	52.18	600	217.58	219.71
-80	68.33	67.76	310	215.61	217.70	-160	57.55	56.79	620	221.51	223.71
-70	72.33	71.84	320	219.15	221.31	-140	62.06	61.37	640	225.42	227.70
-60	76.33	75.90	330	222.68	224.91	-120	66.54	65.94	660	229.32	231.67
-50	80.31	79.95	340	226.20	228.49	-100	71.00	70.48	680	233.21	235.63
-40	84.27	83.99	350	229.71	232.06	-80	75.44	75.00	700	237.09	239.57
-30	88.22	88.01	360	233.21	235.63	-60	79.87	79.50	720	240.94	243.50
-20	92.16	92.02	370	236.70	239.18	-40	84.27	83.99	740	244.79	247.42
-10	96.09	96.02	380	240.17	242.72	-20	88.66	88.46	760	248.62	251.32
0	100.00	100.00	390	243.64	246.24	0	93.03	92.91	780	252.44	255.20
10	103.90	103.97	400	247.09	249.76	20	97.39	97.34	800	256.24	259.07
20	107.79	107.93	410	250.53	253.26	40	101.74	101.77	820	260.03	262.93
30	111.67	111.88	420	253.96	256.75	60	106.07	106.17	840	263.80	266.77
40	115.54	115.82	430	257.38	260.23	80	110.38	110.57	860	267.56	270.60
50	119.40	119.75	440	260.78	263.70	100	114.68	114.95	880	271.30	274.42
60	123.24	123.66	450	264.18	267.16	120	118.97	119.31	900	275.03	278.21
70	127.07	127.56	460	267.56	270.60	140	123.24	123.66	920	278.75	282.00
80	130.90	131.45	470	270.93	274.03	160	127.50	128.00	940	282.45	285.77
90	134.71	135.33	480	274.29	277.46	180	131.74	132.32	960	286.14	289.52
100	138.51	139.20	490	277.64	280.87	200	135.97	136.62	980	289.82	293.27
110	142.29	143.06	500	280.97	284.26	220	140.19	140.91	1000	293.47	296.99
120	146.07	146.90	510	284.30	287.65	240	144.39	145.19	1020	297.12	300.70
130	149.83	150.73	520	287.61	291.02	260	148.58	149.46	1040	300.75	304.40
140	153.58	154.55	530	290.91	294.39	280	152.75	153.70	1060	304.37	308.09
150	157.32	158.36	540	294.20	297.74	300	156.91	157.94	1080	307.97	311.75
160	161.05	162.16	550	297.48	301.08	320	161.05	162.16	1100	311.56	315.41
170	164.77	165.94	560	300.75	304.40	340	165.18	166.36	1120	315.13	319.05
180	168.48	169.71	570	304.01	307.72	360	169.30	170.55	1140	318.69	322.67
190	172.17	173.48	580	307.25	311.02	380	173.40	174.73	1160	322.24	326.28
200	175.85	177.23	590	310.48	314.31	400	177.49	178.89	1180	325.77	329.88
210	179.53	180.96	600	313.70	317.59	420	181.56	183.04	1200	329.28	333.46
220	183.19	184.69	610	316.91	320.86	440	185.62	187.17	1220	332.79	337.03
230	186.83	188.41	620	320.11	324.12	460	189.66	191.29	1240	336.28	340.58
240	190.47	192.11	630	323.30	327.36	480	193.69	195.39	1260	339.75	344.12
250	194.10	195.80	640	326.47	330.60	500	197.71	199.48	1280	343.21	347.64
260	197.71	199.48	650	329.64	333.82	520	201.71	203.55	1300	346.65	351.15
270	201.31	203.15	660	332.79	337.03	540	205.70	207.61	1320	350.09	354.65
280	204.90	206.80	670	335.93	340.23	560	209.67	211.66	1340	353.50	358.13

Tolerance °C

Class A: $\pm(0.15+0.002T)^\circ\text{C}$

Class B: $\pm(0.30+0.005T)^\circ\text{C}$

NOTE: "T" is the actual temperature,
in °C of the platinum element.



Note: For 1000 ohm RTDs multiply resistance shown in table by 10.

Temperature Sensing



Resistance Temperature Sensing

Style RTD1 — Straight Probes

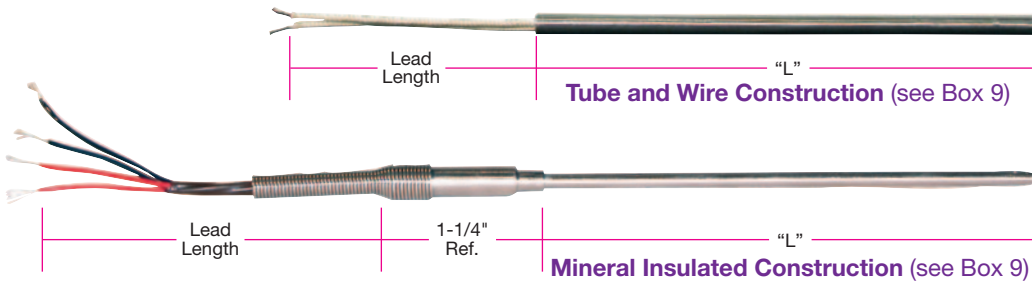

Design Features

* *Platinum Resistance Element*



**Optional Installation
Compression Fitting**
See Box 12

Ordering Information

RTDs are offered with the options listed in the worksheet below. Create an ordering code by filling in the boxes with the appropriate number and/or letter designation for your requirements, and a part number will be assigned.

Two Construction Styles to Suit Any Application

(See Ordering Code Box 9)

* *Standard Industry Tube and Wire construction with fiberglass 900°F (482°C) or Teflon® 392°F (200°C) lead wires*

* *Mineral Insulated construction rated up to 1200°F (650°C). This construction type allows forming and bending the sheath to meet design requirements.*

Ordering Code:

RTD1 - 1 2 3 4 5 6 7 8 9 10 11 12 13

Element BOX 1

S = 100Ω Single **K** = 1000Ω Single
D = 100Ω Dual **L** = 1000Ω Dual
TCR = .00385 ohm/ohm/°C

Lead Wire Length BOX 8

In inches **001** to **999**
 12" (012) Standard

RTD Construction Type BOX 9

T = Tube and Wire Construction
M = MgO Insulated Construction with strain relief spring (Type "M" not available for "K" or "L" from Element Box 1)

Element Class BOX 2

A = ±0.06% at 0°C, Optional
B = ±0.12% at 0°C, Standard

Lead Wire Construction BOX 10

Fiberglass 900°F (482°C)	S	B	A
Teflon® 392°F (200°C)	T	D	F

** Flex Armor options, overbraid options and .125" O.D. and dual constructions may require transitions.*

Number of Leads BOX 3

2 = 2-wire circuit
3 = 3-wire circuit
4 = 4-wire circuit
0.125 O.D. 4-wire circuit not available

Lead Wire Termination BOX 11

P = Standard Male Plug 350°F (177°C)	F = Mini Plug & Mating Jack
J = Standard Female Jack	B = Std.—2-1/2 in. Split Leads
K = Std. Plug with Mating Jack	S = Leads with Spade Lugs
D = Mini Male Plug 350°F (177°C)	C = 2-1/2 in. Split Leads with BX Connector and Spade Lugs
E = Mini Female Jack	X = Other (Specify)

Plugs and Jacks for 2- and 3-Wire Only

Sheath O.D. BOX 4

F = 0.125" (Single Element Only)
G = 0.188"
H = 0.250"
X = Other (Specify)

Optional Compression Fitting BOX 12

1 = 1/8" NPT SS	4 = 1/8" NPT Brass
2 = 1/4" NPT SS	5 = 1/4" NPT Brass
3 = 1/2" NPT SS	6 = 1/2" NPT Brass
0 = None Required	

Sheath Material BOX 5

B = 304 SS
C = 316 SS
A = Alloy 600
 (Type "M" only; See Box 9)

Sheath Length "L" BOX 6

Whole inches
01 to **99**
 For lengths over 99 in. consult TEMPCO.

Sheath Length "L" BOX 7

Fractional inches
0 = 0" **3** = 3/8" **6** = 3/4"
1 = 1/8" **4** = 1/2" **7** = 7/8"
2 = 1/4" **5** = 5/8"

Special Requirements BOX 13

X = Specify
0 = None

⚠ WARNING: Cancer and Reproductive Harm - www.P65Warnings.ca.gov.

Style RTD2 — Plug or Jack Termination

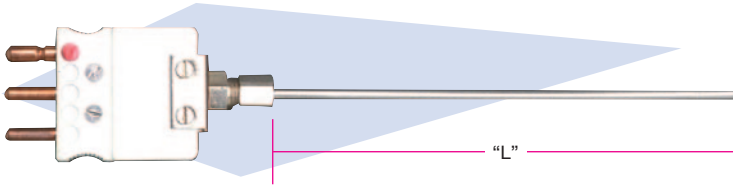

Ordering Information

RTDs are offered with the options listed in the worksheet below. Create an ordering code by filling in the boxes with the appropriate number and/or letter designation for your requirements, and a part number will be assigned.

Design Features

- * *Platinum Resistance Element*
- * *Available with standard or mini, 2- or 3-prong plug or jack*

Two Construction Styles to Suit Any Application

(See Ordering Code Box 9)

- * *Standard Industry Tube and Wire construction with fiberglass 900°F (482°C) or Teflon® 392°F (200°C) lead wires*
- * *Mineral Insulated construction rated up to 1200°F (650°C). This construction type allows forming and bending the sheath to meet design requirements.*

Ordering Code: RTD2 -

Element BOX 1

S = 100Ω Single **K** = 1000Ω Single
D = 100Ω Dual **L** = 1000Ω Dual
TCR = .00385 ohm/ohm/°C

Sheath Length "L" BOX 6

Whole inches
01 to 99
 For lengths over 99 in. consult TEMPCO.

Sheath Length "L" BOX 7

Fractional inches
0 = 0" **3** = 3/8" **6** = 3/4"
1 = 1/8" **4** = 1/2" **7** = 7/8"
2 = 1/4" **5** = 5/8"

Element Class BOX 2

A = ±0.06% at 0°C, Optional
B = ±0.12% at 0°C, Standard

Termination BOX 8

P = Standard Male Plug 350°F (177°C) **D** = Mini Male Plug 350°F (177°C)
J = Standard Female Jack **E** = Mini Female Jack
K = Std. Plug with Mating Jack **F** = Mini Plug with Mating Jack

Number of Leads BOX 3

2 = 2-wire circuit
3 = 3-wire circuit (Dual circuit not available)

RTD Construction Type BOX 9

Standard Industry Construction
S = Fiberglass insulated 900°F (450°C)
T = Teflon® Insulated 392°F (200°C)
Mineral Insulated Construction
M = MgO Insulated 1200°F (650°C)
 (Type "M" not available for "K" or "L" from Element Box 1)

Sheath O.D. BOX 4

F = 0.125" (Single Element Only)
G = 0.188"
H = 0.250"

Optional Compression Fitting BOX 10

1 = 1/8" NPT SS **4** = 1/8" NPT Brass
2 = 1/4" NPT SS **5** = 1/4" NPT Brass
3 = 1/2" NPT SS **6** = 1/2" NPT Brass
0 = None Required

Sheath Material BOX 5

B = 304 SS
C = 316 SS
A = Alloy 600
 (Style M only; See Box 9)

Special Requirements BOX 11

X = Specify
0 = None

⚠ WARNING: Cancer and Reproductive Harm - www.P65Warnings.ca.gov.

(800) 323-6859 • Email: sales@tempco.com



Style RTD3 — Open Disc Termination

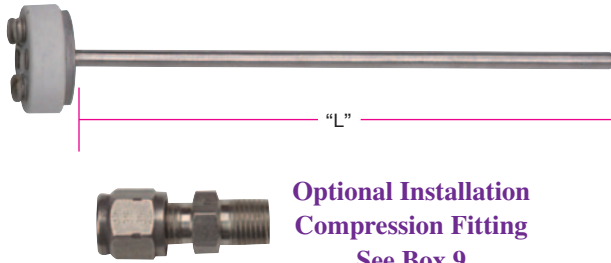

**Optional Installation
Compression Fitting**
See Box 9

Ordering Information

RTDs are offered with the options listed in the worksheet below. Create an ordering code by filling in the boxes with the appropriate number and/or letter designation for your requirements, and a part number will be assigned.

Design Features

- * *Platinum Resistance Element*
- * *Ceramic disc 1-1/8" O.D. for 2-, 3- and 4-wire designs, 2-1/32" O.D. for dual 6-wire design (.188" and .250" O.D. sheath); consult factory for 1/8" sheath O.D.*

Two Construction Styles to Suit Any Application

(See Ordering Code Box 8)

- * *Standard Industry Tube and Wire construction with fiberglass 900°F (482°C) or Teflon® 392°F (200°C) lead wires*
- * *Mineral Insulated construction rated up to 1200°F (650°C). This construction type allows forming and bending the sheath to meet design requirements.*

Ordering Code:

RTD3 -

Element BOX 1

S = 100Ω Single **K** = 1000Ω Single
D = 100Ω Dual **L** = 1000Ω Dual
 TCR = .00385 ohm/ohm/°C

Sheath Length "L" BOX 6

Whole inches
01 to 99
 For lengths over 99 in. consult TEMPCO.

Element Class BOX 2

A = ±0.06% at 0°C, Optional
B = ±0.12% at 0°C, Standard

Sheath Length "L" BOX 7

Fractional inches
0 = 0" **3** = 3/8" **6** = 3/4"
1 = 1/8" **4** = 1/2" **7** = 7/8"
2 = 1/4" **5** = 5/8"

Number of Leads BOX 3

2 = 2-wire circuit
3 = 3-wire circuit
4 = 4-wire circuit
 0.125" O.D. (Dual circuit not available)

RTD Construction Type BOX 8

Standard Industry Construction
S = Fiberglass insulated 900°F (450°C)
T = Teflon® Insulated 392°F (200°C)
Mineral Insulated Construction
M = MgO Insulated 1200°F (650°C)
 (Type "M" not available for "K" or "L" from Element Box 1)

Sheath O.D. BOX 4

F = 0.125"
G = 0.188"
H = 0.250"

Optional Compression Fitting BOX 9

1 = 1/8" NPT SS **4** = 1/8" NPT Brass
2 = 1/4" NPT SS **5** = 1/4" NPT Brass
3 = 1/2" NPT SS **6** = 1/2" NPT Brass
0 = None Required

Sheath Material BOX 5

B = 304 SS
C = 316 SS
A = Alloy 600
 (Type "M" Only; See Box 8)

Special Requirements BOX 10

X = Specify
0 = None

⚠ WARNING: Cancer and Reproductive Harm - www.P65Warnings.ca.gov.

Style RTD4 — Process Connection

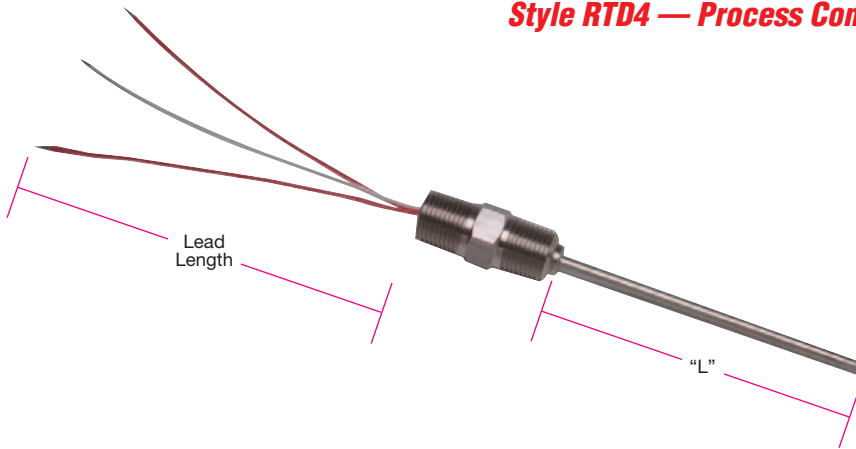

Design Features

- * Platinum Resistance Element
- * Designed for mounting to connection head and thermowells
- * Optional spring loading on 1/2" NPT only
- * Stainless Steel fittings with 1/4" or 1/2" NPT thread

Two Construction Styles to Suit any Application (See Ordering Code Box 11)

- * Standard Industry Tube and Wire construction with fiberglass 900°F (482°C) or Teflon® 392°F (200°C) lead wires.
- * Mineral Insulated construction rated up to 1200°F (650°C). This construction type allows forming and bending the sheath to meet design requirements.

Ordering Information

RTDs are offered with the options listed in the worksheet below. Create an ordering code by filling in the boxes with the appropriate number and/or letter designation for your requirements, and a part number will be assigned.

Ordering Code:

RTD4 -

Element BOX 1

S = 100Ω Single K = 1000Ω Single
D = 100Ω Dual L = 1000Ω Dual
TCR = .00385 ohm/ohm/°C

Sheath Length "L" BOX 6

Whole inches
01 to 99
For lengths over 99 in. consult TEMPCO.

Sheath Length "L" BOX 7

Fractional inches
0 = 0" 3 = 3/8" 6 = 3/4"
1 = 1/8" 4 = 1/2" 7 = 7/8"
2 = 1/4" 5 = 5/8"

Element Class BOX 2

A = ±0.06% at 0°C, Optional
B = ±0.12% at 0°C, Standard

Lead Wire Length BOX 8

In inches 001 to 999
12" (012) Standard

Number of Leads BOX 3

2 = 2-wire circuit
3 = 3-wire circuit
4 = 4-wire circuit
0.125" O.D. (Dual circuit not available)

Thread BOX 9

4 = 1/4" NPT
2 = 1/2" NPT

RTD Construction Type BOX 11

T = Tube and Wire Construction
M = MgO Insulated Construction
(Type "M" not available for "K" or "L" from Element Box 1)

Sheath O.D. BOX 4

F = 0.125"
G = 0.188"
H = 0.250"
X = Other (Specify)

Spring-Loaded BOX 10

O = Not Required
Y = Yes, 1/2" NPT only

Lead Wire Construction BOX 12

Fiberglass Stranded 900° (482°C)	S	w/ SS Braid	B	w/ SS Armor	A
Teflon® Stranded 392°F (200°C)	T		D		F

Sheath Material BOX 5

B = 304 SS
C = 316 SS
A = Alloy 600
(Type M Only; See Box 11)

Special Requirements BOX 13

X = Specify
0 = None

WARNING: Cancer and Reproductive Harm - www.P65Warnings.ca.gov

Temperature Sensing

Resistance Temperature Sensing



Style RTD5 — Handheld Probe

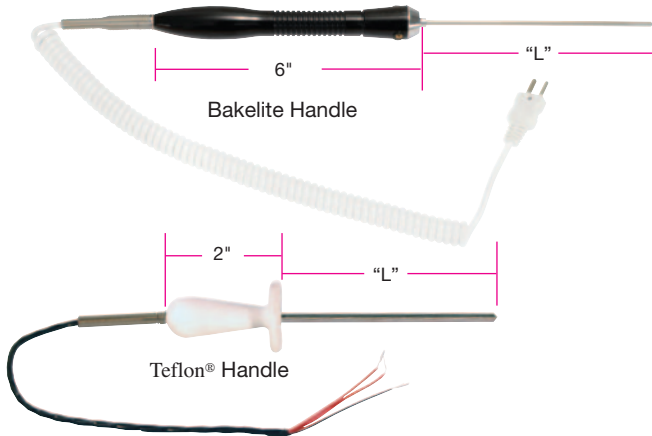

Design Features

- * **Platinum Resistance Element**
- * **Ground conical point for easy meat penetration**
- * **Large handle makes penetration and removal easy**
- * **Teflon® insulated lead wire construction good to 392°F (200°C)**
- * **Fiberglass lead wire construction good to 900°F (482°C)**
- * **3-wire coil cord construction good to 221°F (105°C). Not available with overbraid or flex armor. Extended length 5 or 15 ft. (standard).**

Ordering Information

RTDs are offered with the options listed in the worksheet below. Create an ordering code by filling in the boxes with the appropriate number and/or letter designation for your requirements, and a part number will be assigned.

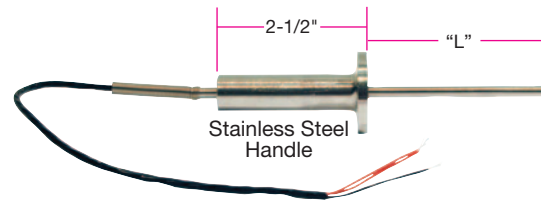

Ordering Code:

RTD5 -

Element BOX 1

S = 100Ω Single **K** = 1000Ω Single
D = 100Ω Dual **L** = 1000Ω Dual
TCR = .00385 ohm/ohm/°C

Sheath Length "L" BOX 6

Whole inches
01 to 99
 For lengths over 99 in. consult TEMPCO.

Sheath Length "L" BOX 7

Fractional inches
0 = 0" **3** = 3/8" **6** = 3/4"
1 = 1/8" **4** = 1/2" **7** = 7/8"
2 = 1/4" **5** = 5/8"

Element Class BOX 2

A = ±0.06% at 0°C, Optional
B = ±0.12% at 0°C, Standard

Lead Wire Length BOX 8

In inches **012 to 999**
 60" (060) Standard
For Coil Cords Enter 060 or 180

Number of Leads BOX 3

2 = 2-wire circuit
3 = 3-wire circuit
4 = 4-wire circuit
0.125" O.D. (Dual circuit not available)

Lead Wire Construction BOX 9

	Standard	w/ SS Overbraid	w/ Flex Armor
Coil Cord 221°F (105°C)	C	-	-
Fiberglass Stranded 900°F (482°C)	S	B	A
Teflon® Stranded 392°F (200°C)	T	D	F

Sheath O.D. BOX 4

F = 0.125"
G = 0.188"
H = 0.250"
X = Other (Specify)

Lead Wire Termination BOX 10

P = Standard Male Plug 350°F (177°C) **F** = Mini Plug with Mating Jack
J = Standard Female Jack **B** = Split Leads
K = Std. Plug with Mating Jack **S** = Leads with Spade Lugs
D = Mini Male Plug 350°F (177°C) **C** = 2.5 in. with BX Connector and Spade Lugs
E = Mini Female Jack

Plugs and Jacks for 2- and 3-Wire Only

Sheath Material BOX 5

B = 304 SS
C = 316 SS

Handle Type BOX 11

1 = Stainless Steel
2 = Teflon® 500°F (260°C)
3 = Bakelite 400°F (204°C)

Special Requirements BOX 12

X = Specify
0 = None

⚠ WARNING: Cancer and Reproductive Harm - www.P65Warnings.ca.gov.



Style RTD6 — Connection Head

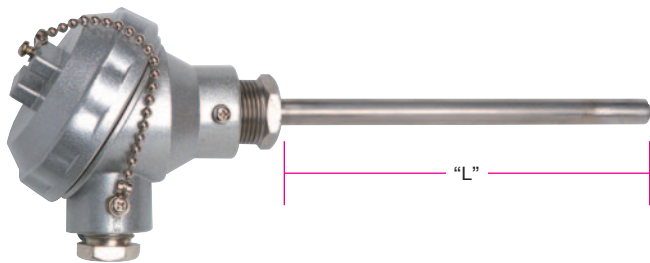

**Optional Installation
Compression Fitting**
See Box 10

Design Features

- * *Platinum Resistance Element in single or dual circuit.*
- * *Tempco's connection heads are gasketed to seal against moisture, dust and corrosive or hostile atmospheres.*
- * *Screw covers are attached to body with a stainless steel chain and screws.*
- * *Tempco's connection heads are available in die cast aluminum, cast iron, stainless steel and Bakelite. Explosion proof heads are also available in aluminum and stainless steel.*

Two Construction Styles to Suit Any Application (See Ordering Code Box 9)

- * *Standard Industry Tube and Wire construction with fiberglass 900°F (482°C) or Teflon® 392°F (200°C) lead wires*
- * *Mineral Insulated construction rated up to 1200°F (650°C). This construction type allows forming and bending the sheath to meet design requirements.*

Ordering Information

RTDs are offered with the options listed in the worksheet below. Create an ordering code by filling in the boxes with the appropriate number and/or letter designation for your requirements, and a part number will be assigned.

Ordering Code:

RTD6 -

Element BOX 1

S = 100Ω Single **K** = 1000Ω Single
D = 100Ω Dual **L** = 1000Ω Dual
TCR = .00385 ohm/ohm/°C

Sheath Length "L" BOX 6

Whole inches
01 to 99
 For lengths over 99 in. consult TEMPCO.

Sheath Length "L" BOX 7

Fractional inches
0 = 0" **3** = 3/8" **6** = 3/4"
1 = 1/8" **4** = 1/2" **7** = 7/8"
2 = 1/4" **5** = 5/8"

Element Class BOX 2

A = ±0.06% at 0°C, Optional
B = ±0.12% at 0°C, Standard

Connection Head BOX 8

A = Standard Size Aluminum **P** = Polypropylene
B = Medium Size Aluminum **N** = Miniature Nickel-Plated Steel
C = Miniature Aluminum **S** = Stainless Steel
H = Standard Cast Iron **E** = Explosion Proof (Aluminum)
F = Standard Bakelite **T** = Explosion Proof (Stainless Steel)
Note: Conduit connection for A, F, H & S is 1/2" (3/4" available);
 for B & C is 3/8"; and for P is 3/4" NPT.
 For overall dimensions see pages 14-98 through 14-100.
 Type "N" not available with Dual 3-Wire

Number of Leads BOX 3

2 = 2-wire circuit
3 = 3-wire circuit
4 = 4-wire circuit (Dual circuit not available)
0.125" O.D. (Dual circuit not available)

RTD Construction Type BOX 9

Standard Industry Construction
S = Fiberglass insulated 900°F (450°C)
T = Teflon® Insulated 392°F (200°C)
Mineral Insulated Construction
M = MgO Insulated 1200°F (650°C)
 (Type "M" not available for "K"
 or "L" from Element Box 1)

Sheath O.D. BOX 4

F = 0.125"
G = 0.188"
H = 0.250"

Sheath Material BOX 5

B = 304 SS
C = 316 SS
A = Alloy 600
 (Type "M" Only; See Box 9)

Optional Compression Fitting BOX 10

1 = 1/8" NPT SS **4** = 1/8" NPT Brass
2 = 1/4" NPT SS **5** = 1/4" NPT Brass
3 = 1/2" NPT SS **6** = 1/2" NPT Brass
0 = None Required

Special Requirements BOX 11

X = Specify
0 = None

⚠ WARNING: Cancer and Reproductive Harm - www.P65Warnings.ca.gov.

(800) 323-6859 • Email: sales@tempco.com

Temperature Sensing

Resistance Temperature Sensing



Style RTD7 — Connection Head with 1/2" NPT Hex Nipple

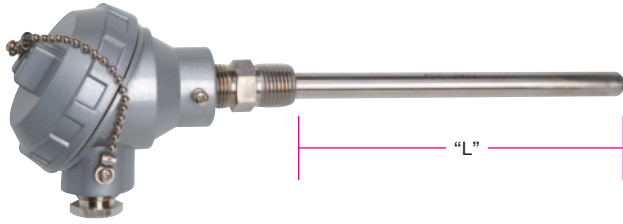

Two Construction Styles to suit any application

(See Ordering Code Box 10)

- * **Standard Industry Tube and Wire construction with fiberglass 900°F (482°C) or Teflon® 392°F (200°C) lead wires.**
- * **Mineral Insulated construction rated up to 1200°F (650°C). This construction type allows forming and bending the sheath to meet design requirements.**

Design Features

- * **Platinum Resistance Element.**
- * **Tempco's connection heads are gasketed to seal against moisture, dust and corrosive or hostile atmospheres.**
- * **Screw covers are attached to body with a plated chain.**
- * **Covers have lugs for tightening or loosening with a screwdriver or wrench.**
- * **Available in single or duplex.**
- * **Tempco's connection heads are available in die cast aluminum, Bakelite and cast iron in a variety of sizes from miniature for confined areas, to the large universal head designed for heavy process and industrial applications. See sensor accessories on pages 14-98 through 14-100 for complete information.**

Ordering Information

RTDs are offered with the options listed in the worksheet below. Create an ordering code by filling in the boxes with the appropriate number and/or letter designation for your requirements, and a part number will be assigned.

Ordering Code: **RTD7** -

Element BOX 1

S = 100Ω Single **K** = 1000Ω Single
D = 100Ω Dual **L** = 1000Ω Dual
 TCR = .00385 ohm/ohm/°C

Sheath Length "L" BOX 6

Whole inches
01 to 99
 For lengths over 99 in. consult TEMPCO.

Sheath Length "L" BOX 7

Fractional inches
0 = 0" **3** = 3/8" **6** = 3/4"
1 = 1/8" **4** = 1/2" **7** = 7/8"
2 = 1/4" **5** = 5/8"

Element Class BOX 2

A = ±0.06% at 0°C, Optional
B = ±0.12% at 0°C, Standard

Connection Head BOX 8

A = Standard Size Aluminum **S** = Stainless Steel
B = Medium Size Aluminum **F** = Standard Bakelite
C = Miniature Aluminum **P** = Polypropylene
H = Standard Cast Iron
Note: Conduit connection for A, F, H & S is 1/2" (3/4" available); for B & C is 3/8"; and for P is 3/4" NPT.
 For overall dimensions see pages 14-98 through 14-100.

Number of Leads BOX 3

2 = 2-wire circuit
3 = 3-wire circuit
4 = 4-wire circuit (Dual circuit not available)
 0.125" O.D. (Dual circuit not available)

Spring-Loaded Terminal Block BOX 9

O = Not Required
Y = Required

Sheath O.D. BOX 4

F = 0.125"
G = 0.188"
H = 0.250"

RTD Construction Type BOX 10

Standard Industry Construction
S = Fiberglass insulated 900°F (450°C)
T = Teflon® Insulated 392°F (200°C)
Mineral Insulated Construction
M = MgO Insulated 1200°F (650°C)
 (Type "M" not available for "K" or "L" from Element Box 1)

Sheath Material BOX 5

B = 304 SS
C = 316 SS
A = Alloy 600
 (Type "M" Only; See Box 10)

Special Requirements BOX 11

X = Specify
0 = None

WARNING: Cancer and Reproductive Harm - www.P65Warnings.ca.gov.

Style RTD8 — Connection Head with 1/2" NPT Pipe Nipple

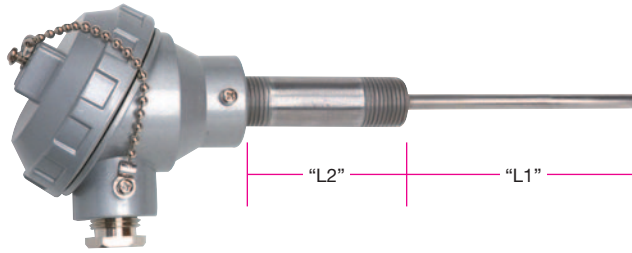

Two Construction Styles to Suit Any Application

(See Ordering Code Box 11)

- * Standard Industry Tube and Wire construction with fiberglass 900°F (482°C) or Teflon® 392°F (200°C) lead wires.
- * Mineral Insulated construction rated up to 1200°F (650°C). This construction type allows forming and bending the sheath to meet design requirements.

Design Features

- * Platinum Resistance Element.
- * Tempco's connection heads are gasketed to seal against moisture, dust and corrosive or hostile atmospheres.
- * Screw covers are attached to body with a plated chain.
- * Covers have lugs for tightening or loosening with a screwdriver or wrench.
- * Available in single or duplex.
- * Tempco's connection heads are available in die cast aluminum, Bakelite and cast iron in a variety of sizes from miniature for confined areas, to the large universal head designed for heavy process and industrial applications. See sensor accessories on pages 14-98 through 14-100 for complete information.
- * Pipe Nipple is galvanized.

Ordering Information

RTDs are offered with the options listed in the worksheet below. Create an ordering code by filling in the boxes with the appropriate number and/or letter designation for your requirements, and a part number will be assigned.

Ordering Code:

RTD8 - 1 2 3 4 5 6 7 8 9 10 11 12

Element BOX 1

S = 100Ω Single K = 1000Ω Single
 D = 100Ω Dual L = 1000Ω Dual
 TCR = .00385 ohm/ohm/°C

Sheath Length "L1" BOX 6

Whole inches
 01 to 99
 For lengths over 99 in. consult TEMPCO.

Sheath Length "L1" BOX 9

Fractional inches
 0 = 0" 2 = 1/4" 4 = 1/2" 6 = 3/4"
 1 = 1/8" 3 = 3/8" 5 = 5/8" 7 = 7/8"

Element Class BOX 2

A = ±0.06% at 0°C, Optional
 B = ±0.12% at 0°C, Standard

"L2" 1/2" NPT Nipple Length BOX 8

Whole inches 03 to 18
 For lengths over 18 in. consult TEMPCO.
 Standard Lengths S1 = 1", S2 = 2-1/2", S3 = 5-1/2"

Number of Leads BOX 3

2 = 2-wire circuit
 3 = 3-wire circuit
 4 = 4-wire circuit (Dual circuit not available)
 0.125" O.D. (Dual circuit not available)

Connection Head BOX 9

A = Standard Size Aluminum S = Stainless Steel
 B = Medium Size Aluminum F = Standard Bakelite
 C = Miniature Aluminum P = Polypropylene
 H = Standard Cast Iron
 Note: Conduit connection for A, F, H & S is 1/2" (3/4" available);
 for B & C is 3/8"; and for P is 3/4" NPT.
 For overall dimensions see pages 14-98 through 14-100.

Sheath O.D. BOX 4

F = 0.125"
 G = 0.188"
 H = 0.250"

Spring-Loaded Terminal Block BOX 10

O = Not Required
 Y = Required

Sheath Material BOX 5

B = 304 SS
 C = 316 SS
 A = Alloy 600
 (Type "M" Only; See Box 11)

RTD Construction Type BOX 11

Standard Industry Construction
 S = Fiberglass insulated 900°F (450°C)
 T = Teflon® Insulated 392°F (200°C)
 Mineral Insulated Construction
 M = MgO Insulated 1200°F (650°C)
 (Type "M" not available for "K"
 or "L" from Element Box 1)

Special Requirements BOX 12

X = Specify
 0 = None

⚠ WARNING: Cancer and Reproductive Harm - www.P65Warnings.ca.gov.

(800) 323-6859 • Email: sales@tempco.com

Temperature Sensing

Resistance Temperature Sensing



Style RTD9 — Connection Head with 1/2" NPT Nipple, Union, Nipple

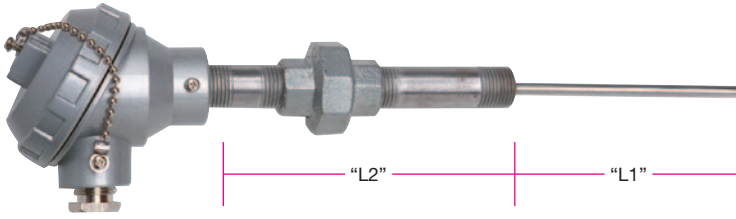

Two Construction Styles to Suit Any Application

(See Ordering Code Box 11)

- * Standard Industry Tube and Wire construction with fiberglass 900°F (482°C) or Teflon® 392°F (200°C) lead wires
- * Mineral Insulated construction rated up to 1200°F (650°C). This construction type allows forming and bending the sheath to meet design requirements.

Ordering Code:

RTD9 -

Design Features

- * Platinum Resistance Element.
- * Tempco's connection heads are gasketed to seal against moisture, dust and corrosive or hostile atmospheres.
- * Screw covers are attached to body with a plated chain.
- * Covers have lugs for tightening or loosening with a screwdriver or wrench.
- * Available in single or duplex.
- * Tempco's connection heads are available in die cast aluminum, bakelite and cast iron in a variety of sizes from miniature for confined areas, to the large universal head designed for heavy process and industrial applications. See sensor accessories on pages 14-98 through 14-100 for complete information.
- * Nipple-Union-Nipple is galvanized.

Ordering Information

RTDs are offered with the options listed in the worksheet below. Create an ordering code by filling in the boxes with the appropriate number and/or letter designation for your requirements, and a part number will be assigned.

Element BOX 1

S = 100Ω Single K = 1000Ω Single
D = 100Ω Dual L = 1000Ω Dual
TCR = .00385 ohm/ohm/°C

Sheath Length "L1" BOX 6

Whole inches
01 to 99
For lengths over 99 in. consult TEMPCO.

Sheath Length "L1" BOX 7

Fractional inches
0 = 0" 3 = 3/8" 6 = 3/4"
1 = 1/8" 4 = 1/2" 7 = 7/8"
2 = 1/4" 5 = 5/8"

Element Class BOX 2

A = ±0.06% at 0°C, Optional
B = ±0.12% at 0°C, Standard

"L2" Dimension (in.) BOX 8

Nipple, Union, Nipple in whole inches
Standard Lengths S1 = 3-1/2", S2 = 6-1/2", S3 = 12-1/2"

Number of Leads BOX 3

2 = 2-wire circuit
3 = 3-wire circuit
4 = 4-wire circuit (Dual circuit not available)
0.125" O.D. (Dual circuit not available)

Connection Head BOX 9

A = Standard Size Aluminum S = Stainless Steel
B = Medium Size Aluminum F = Standard Bakelite
C = Miniature Aluminum P = Polypropylene
H = Standard Cast Iron
Note: Conduit connection for A, F, H & S is 1/2" (3/4" available); for B & C is 3/8"; and for P is 3/4" NPT.
For overall dimensions see pages 14-98 through 14-100.

Sheath O.D. BOX 4

F = 0.125"
G = 0.188"
H = 0.250"

Spring-Loaded Terminal Block BOX 10

O = Not Required
Y = Required

Sheath Material BOX 5

B = 304 SS
C = 316 SS
A = Alloy 600
(Type "M" Only; See Box 11)

RTD Construction Type BOX 11

Standard Industry Construction
S = Fiberglass insulated 900°F (450°C)
T = Teflon® Insulated 392°F (200°C)
Mineral Insulated Construction
M = MgO Insulated 1200°F (650°C)
(Type "M" not available for "K" or "L" from Element Box 1)

Special Requirements BOX 12

X = Specify
0 = None

WARNING: Cancer and Reproductive Harm - www.P65Warnings.ca.gov.

RTDs with Transmitter and Connection Head

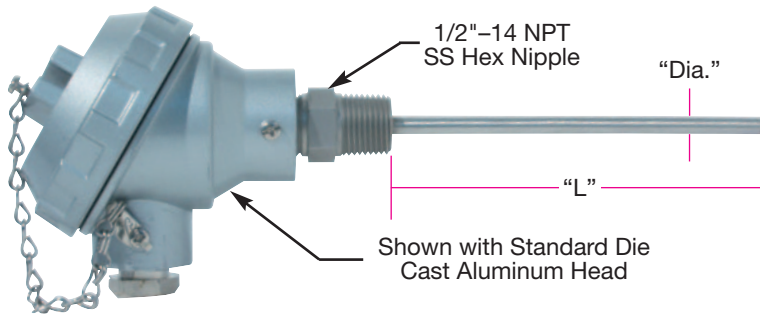

Design Features

- * 100 ohm RTD
- * 4-20mA Programmable Linear Output Transmitter
- * Available with Spring-Loaded Sheath
- * Temperature Range of -58°F to 500°F (-50° to 260°C)
- * Transmitter Accuracy of +/0.2% of temperature span
- * For field programming of the temperature transmitter see Part Number ETM90006 on page 12-45
- * Available in Single 3-wire Circuit only
- * 1/2" NPT process connection

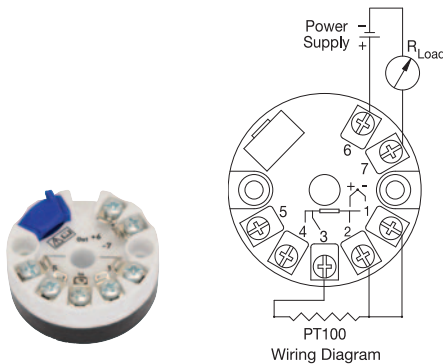

Transmitter Ambient Temperature Range:
-40° to +185°F (-40° to +85°C)
Refer to page 12-44 for complete details.



EMT10001



EMT20001

See Connection Head Box 7 below.

Refer to page 12-50 for complete Indicator specifications.

Ordering Information

RTDs are offered with the options listed in the worksheet below. Create an ordering code by filling in the boxes with the appropriate number and/or letter designation for your requirements, and a part number will be assigned.

Ordering Code: **RTM** -

Element Class BOX 1

- A** = +/-0.06% At 0°C (Optional)
- B** = +/-0.12% At 0°C (Standard)

Sheath O.D. BOX 2

- F** = .125"
- G** = .188"
- H** = .250"

Sheath Material BOX 3

- B** = 304 SS
- C** = 316 SS

Sheath Length "L" BOX 4

- Whole inches
- 01** to **99**

Sheath Length "L" BOX 5

- Fractional inches
- 0** = 0" **3** = 3/8" **6** = 3/4"
- 1** = 1/8" **4** = 1/2" **7** = 7/8"
- 2** = 1/4" **5** = 5/8"

Transmitter Type BOX 6 (Enter Code Below)

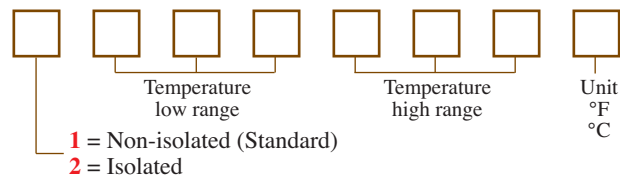

Connection Head BOX 7

- A** = Standard Aluminum **H** = Standard Cast Iron
- B** = Medium Size Aluminum **L** = Aluminum Head with LCD Indicator (EMT10001)
- S** = Stainless Steel
- P** = Polypropylene Head (FDA Approved) **M** = Heavy Duty Aluminum Head with LCD Indicator (EMT20001)

Note: Conduit connection for A, H & S is 1/2", for B is 3/8" NPT, for P is 3/4" NPT. For overall dimensions see pages 14-98 through 14-100.

Spring-Loaded Probe BOX 8

- 0** = Not Required
- Y** = Required

Special Requirements BOX 9

- X** = Specify
- 0** = None

⚠ WARNING: Cancer and Reproductive Harm - www.P65Warnings.ca.gov.

Temperature Sensing

Resistance Temperature Sensing



Sanitary RTDs



Design Features

- * Platinum Resistance Element
- * Ideal for Food and Dairy Applications
- * 316 SS Construction
- * Available in Standard .250 dia. Tip or Optional .500 dia. Reduced to .250 dia.
- * Improved Response Time
- * Welded and Highly Polished Components
- * Operating Temperature Range of -58° to 500°F (-50° to 260°C)

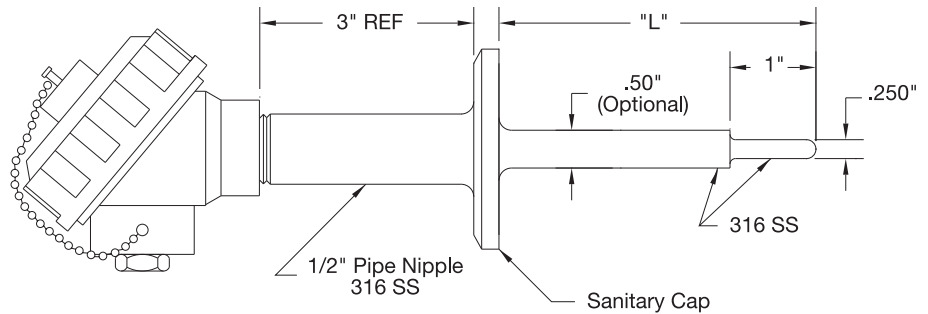

Ordering Code: **RTS** -

Diameter BOX 1

- 1** = 0.250"
- 2** = 0.500" with .250" tip

Element BOX 2

- S** = 100Ω Single **K** = 1000Ω Single
- D** = 100Ω Dual **L** = 1000Ω Dual
- TCR** = .00385 ohm/ohm/°C

Element Class BOX 3

- A** = ±0.06% at 0°C, Optional
- B** = ±0.12% at 0°C, Standard

Number of Leads BOX 4

- 2** = 2-wire circuit
- 3** = 3-wire circuit
- 4** = 4-wire circuit (*Dual Circuit not available*)

Sanitary Cap Type BOX 5

- (Standard Finish)
- A** = 16 AMP Tri-Clover
- X** = Other (Specify)

Sanitary Cap Size BOX 6

- A** = 1-1/2"
- B** = 2"
- C** = 2-1/2"
- D** = 3"
- X** = Other (Specify)

Sheath Length "L" BOX 7

- Whole inches
- 01 to 99**

Sheath Length "L" BOX 8

- Fractional inches
- 0** = 0" **3** = 3/8" **6** = 3/4"
- 1** = 1/8" **4** = 1/2" **7** = 7/8"
- 2** = 1/4" **5** = 5/8"

Connection Head BOX 9

- P** = Polypropylene Head (FDA Approved)
- A** = Standard Die Cast Aluminum Head
- S** = Stainless Steel
- Note: Conduit connection for A & S is 1/2", and for B is 3/4". For overall dimensions see pages 14-98 to 14-100.

Special Requirements BOX 10

- X** = Specify
- 0** = None

⚠ WARNING: Cancer and Reproductive Harm - www.P65Warnings.ca.gov.

Bayonet Style RTDs for the Plastics Industry

Design Features

- * 3/16" diameter stainless steel probe
- * 3-wire circuit
- * Operating temp. 392°F (200°C); 900°F (482°C) available
- * 100 ohms Class B element per IEC 751
- * Can be installed wherever existing thermocouples of similar design are used

Style 1 – Adjustable Spring Bayonet RTD

- * Insertion length adjustable from 1" to 10"
- * One can replace several fixed-length thermocouples
- * Forms easily to any angle

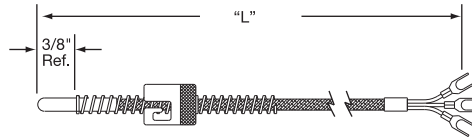

See Page 14-87 for Bayonet Adapters.

Stock Items Are Shown In **RED**

Part Number	Termination Style [†]	"L" Dim. (in)
RTP10001	S	48
RTP10002	C	48
RTP10003	P	48
RTP10004	J	48
RTP10005	B	48

[†] See page 14-64 for Termination Style descriptions.

Ordering Information

RTDs are offered with the options listed in the worksheet below. Create an ordering code by filling in the boxes with the appropriate number and/or letter designation for your requirements, and a part number will be assigned.

Style 2 – Adjustable Armor Cable Bayonet RTD

- * Insertion length adjustable over length of armor cable
- * One can replace several fixed-length thermocouples or RTDs
- * Forms easily to any angle

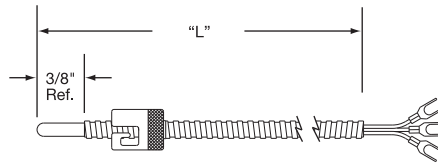

Stock Items Are Shown In **RED**

Part Number	Termination Style [†]	"L" Dim. (in)
RTP20001	S	48
RTP20002	C	48
RTP20003	P	48
RTP20004	J	48
RTP20005	B	48

[†] See page 14-64 for Termination Style descriptions.

Ordering Code:

RTP -
 1
2
3
4
5
6
7
8

Style BOX 1

- 1 = Spring Adjustable
- 2 = Armor Cable Adjustable

"L" Dimension BOX 5

Whole inches
012 to 999

Element BOX 2

- S = 100Ω Single
- D = 100Ω Dual

Lead Insulation BOX 6

Fiberglass 900°F (482°C)	(Style 1 only)	w/ SS Overbraid (Style 1 only)	w/ SS Armor Cable (Style 2 only)
Teflon® 392°F (200°C)	S T	B D	A F

Element Class BOX 3

- A = ±0.06% at 0°C, Optional
- B = ±0.12% at 0°C, Standard

Termination BOX 7[†]

- | | |
|-------------------------------------|-----------------------------------|
| B = 2-1/2 in. Split Leads | K = Standard Plug and Jack |
| S = Spade Lugs | D = Miniature Plug |
| C = Spade Lugs with BX Conn. | E = Miniature Jack |
| P = Standard Plug | F = Mini. Plug and Jack |
| J = Standard Jack | X = Other (Specify) |

Plugs and Jacks for 2- and 3-Wire Only

[†] See page 14-64 for Termination Style descriptions.

Number of Leads BOX 4

- 2 = 2-wire circuit
- 3 = 3-wire circuit
- 4 = 4-wire circuit*
- *Not available with dual element

Special Requirements BOX 8

- X = Specify
- 0 = None

⚠ WARNING: Cancer and Reproductive Harm - www.P65Warnings.ca.gov.

(800) 323-6859 • Email: sales@tempco.com

CONTINUED

Bayonet Style RTDs for the Plastics Industry

Design Features

- * 3/16" diameter stainless steel probe
- * Operating temp. 392°F (200°C); 900°F (482°C) available
- * 3-wire circuit
- * 100 ohms Class B element per IEC 751
- * Can be installed wherever existing thermocouples of similar design are used

Style 3—Rigid Straight Bayonet RTD

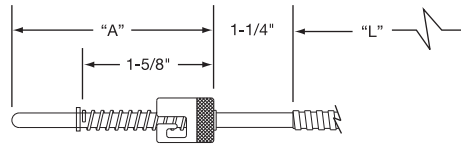

Part Number	Termination Style†	"A" Dim. (in)	"L" Dim. (in)
RTP30001	S	4	48
RTP30002	C	4	48
RTP30003	P	4	48
RTP30004	J	4	48
RTP30005	B	4	48

Style 4—Rigid 45° Bend Bayonet RTD

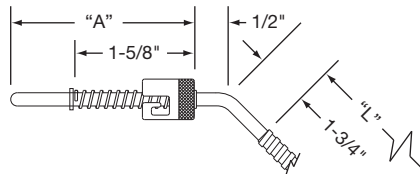

Part Number	Termination Style†	"A" Dim. (in)	"L" Dim. (in)
RTP40001	S	4	48
RTP40002	C	4	48
RTP40003	P	4	48
RTP40004	J	4	48
RTP40005	B	4	48

Style 5—Rigid 90° Bend Bayonet RTD

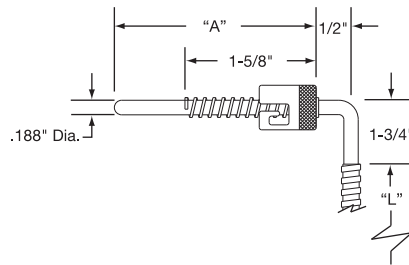

Part Number	Termination Style†	"A" Dim. (in)	"L" Dim. (in)
RTP50001	S	4	48
RTP50002	C	4	48
RTP50003	P	4	48
RTP50004	J	4	48
RTP50005	B	4	48

†See Page 14-64 for Termination Style descriptions.

Ordering Information

RTDs are offered with the options listed in the worksheet below. Create an ordering code by filling in the boxes with the appropriate number and/or letter designation for your requirements, and a part number will be assigned.

Custom Made Bayonet Style RTDs

Ordering Code: RTP -

Style BOX 1

- 3 = Straight
- 4 = 45° Bend
- 5 = 90° Bend

Element BOX 2

- S = 100Ω Single
- D = 100Ω Dual

Element Class BOX 3

- A = ±0.06% at 0°C, Optional
- B = ±0.12% at 0°C, Standard

Number of Leads BOX 4

- 2 = 2-wire circuit
 - 3 = 3-wire circuit
 - 4 = 4-wire circuit*
- *Not available with dual element

"A" Dimension BOX 5

- Whole inches
- 01 to 99 (1-3/4 in. min.)

"A" Dimension BOX 6

- Fractional inches
- 0 = 0" 3 = 3/8" 6 = 3/4"
- 1 = 1/8" 4 = 1/2" 7 = 7/8"
- 2 = 1/4" 5 = 5/8"

"L" Dimension BOX 7

- Whole inches
- 000 to 999

Termination BOX 9 †

- B = 2-1/2 in. Split Leads
- S = Spade Lugs
- C = Spade Lugs with BX Conn.
- P = Standard Plug
- J = Standard Jack
- K = Standard Plug and Jack
- D = Miniature Plug
- E = Miniature Jack
- F = Mini. Plug and Jack
- X = Other (Specify)

†See Page 14-64 for Termination Style descriptions.

Plugs and Jacks for 2- and 3-Wire Only

Special Requirements BOX 10

- X = Specify
- 0 = None

Lead Insulation BOX 8

	Standard	w/ SS Overbraid	w/ SS Armor Cable
Fiberglass 900°F (482°C)	S	B	A
Teflon® 392°F (200°C)	T	D	F

WARNING: Cancer and Reproductive Harm - www.P65Warnings.ca.gov.

Compression Fitting Style RTDs for the Plastics Industry

Style 6—Rigid Straight Compression Fitting RTD

Part Number	Termination Style†	"A" Dim. (in)	"L" Dim. (in)
RTP60001	S	4	48
RTP60002	C	4	48
RTP60003	P	4	48
RTP60004	J	4	48
RTP60005	B	4	48

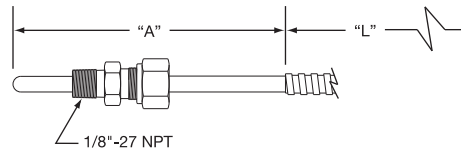

Design Features

- * 3/16" diameter stainless steel probe
- * Operating temp. 392°F (200°C); 900°F (482°C) available
- * One-time adjustable 1/8"-27 NPT brass compression fitting
- * 3-wire circuit
- * 100 ohms Class B element per IEC 751
- * Can be installed wherever existing thermocouples of similar design are used

Style 7—Rigid 45° Bend Compression Fitting RTD

Part Number	Termination Style†	"A" Dim. (in)	"L" Dim. (in)
RTP70001	S	4	48
RTP70002	C	4	48
RTP70003	P	4	48
RTP70004	J	4	48
RTP70005	B	4	48

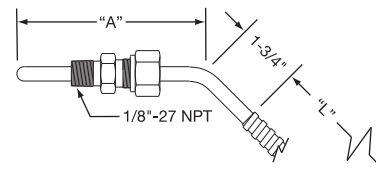

Style 8—Rigid 90° Bend Compression Fitting RTD

Part Number	Termination Style†	"A" Dim. (in)	"L" Dim. (in)
RTP80001	S	4	48
RTP80002	C	4	48
RTP80003	P	4	48
RTP80004	J	4	48
RTP80005	B	4	48

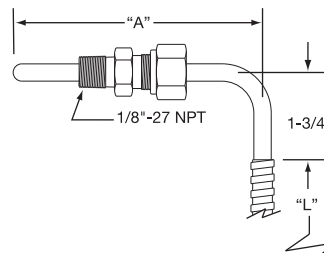

†See Page 14-64 for Termination Style descriptions.

Ordering Information

RTDs are offered with the options listed in the worksheet below. Create an ordering code by filling in the boxes with the appropriate number and/or letter designation for your requirements, and a part number will be assigned.

Custom Made Compression Fitting Style RTDs

Ordering Code: **RTP** -

Style BOX 1
 6 = Straight
 7 = 45° Bend
 8 = 90° Bend

Element BOX 2
 S = 100Ω Single
 D = 100Ω Dual

Element Class BOX 3
 A = ±0.06% at 0°C, Optional
 B = ±0.12% at 0°C, Standard

Number of Leads BOX 4
 2 = 2-wire circuit
 3 = 3-wire circuit
 4 = 4-wire circuit*
 *Not available with dual element

"A" Dimension BOX 5
 Whole inches
 01 to 99 (1-3/4 in. min.)

"A" Dimension BOX 6
 Fractional inches
 0 = 0" 3 = 3/8" 6 = 3/4"
 1 = 1/8" 4 = 1/2" 7 = 7/8"
 2 = 1/4" 5 = 5/8"

"L" Dimension BOX 7
 Whole inches
 000 to 999

Lead Insulation BOX 8

	Standard	w/ SS Overbraid	w/ SS Armor Cable
Fiberglass 900°F (482°C)	S	B	A
Teflon® 392°F (200°C)	T	D	F

Termination BOX 9 †
 B = 2-1/2 in. Split Leads
 S = Spade Lugs
 C = Spade Lugs with BX Conn.
 P = Standard Plug
 J = Standard Jack
 K = Standard Plug and Jack
 D = Miniature Plug
 E = Miniature Jack
 F = Mini. Plug and Jack
 X = Other (Specify)

Plugs and Jacks for 2- and 3-Wire Only

Special Requirements BOX 10
 X = Specify
 0 = None

†See Page 14-64 for Termination Style descriptions.

⚠ WARNING: Cancer and Reproductive Harm - www.P65Warnings.ca.gov.

Temperature Sensing



RTD Termination Styles

RTD Termination Styles

Style B—Plain Ends

Style S—Spade Lugs

Style C—Spade Lugs with BX connector

Optional Termination Styles

Available for the following RTDs:

Style	Page
RTD1	14-50
RTD4	14-53
RTD5	14-54
RTP	14-61 through 14-63

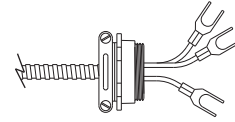
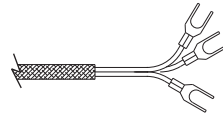
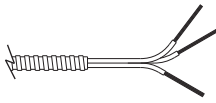

Style P—Standard Plug
(3-wire shown)

Style J—Standard Jack
(3-wire shown)

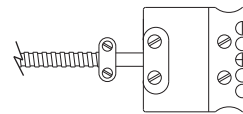
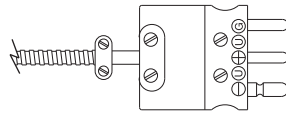

Style D—Miniature Plug
(2-wire shown)

Style E—Miniature Jack
(2-wire shown)

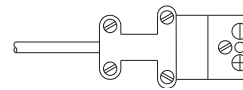
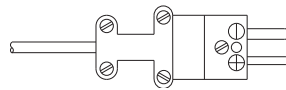

ECR Style RTD Extension Assemblies

(3-wire circuits shown, 2-wire circuits also available)

Termination 1

Termination 2

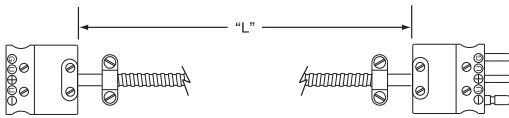

Style RJP—Jack to Plug

Termination 1

Termination 2

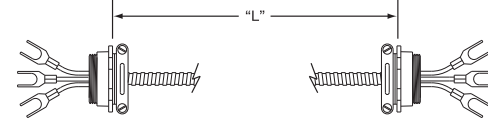

Style RCC—BX Connector to BX Connector

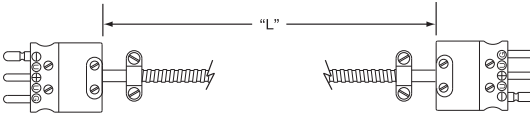

Style RPP—Plug to Plug

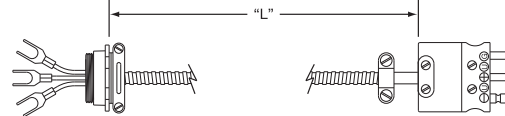

Style RCP—BX Connector to Plug

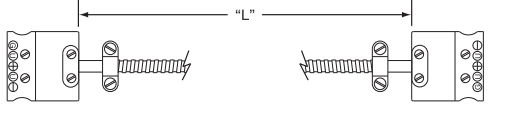

Style RJJ—Jack to Jack

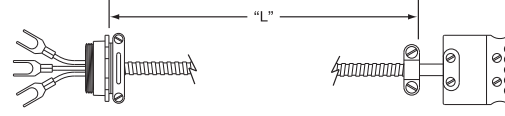

Style RCJ—BX Connector to Jack

Ordering Code: **ECR** -

Number of Leads BOX 1

- 2 = 2-wire circuit
- 3 = 3-wire circuit
- 4 = 4-wire circuit*

*Plugs and Jacks not available

"L" Dimension BOX 4

Whole inches
001 to 999

Termination (Specify for Both Ends) BOXES 2 & 3

- B = 2-1/2 in. Split Leads
- S = Spade Lugs
- C = Spade Lugs with BX Conn.
- P* = Standard Plug
- J* = Standard Jack
- D* = Miniature Plug
- E* = Miniature Jack
- X = Other (Specify)

*Plugs and Jacks for 2- and 3-Wire Only

Lead Insulation BOX 5

	Standard	w/ SS Overbraided	w/ SS Armor Cable
Fiberglass 900°F (482°C)	S	B	A
Teflon® 392°F (200°C)	T	D	F

Special Requirements BOX 6

- X = Specify
- 0 = None

⚠ WARNING: Cancer and Reproductive Harm - www.P65Warnings.ca.gov.

Melt Bolt RTDs for Plastics Extruders or Injection Molding Machines

Design Features

- * 3/16" diameter Probe
- * 100 ohm Class B element per IEC 751
- * 3-wire circuit
- * Can be installed wherever standard melt thermocouples are used
- * Operating temp. 392°F (200°C), 900°F (482°C) available
- * Available in 3" and 6" bolt designs
- * Bolts and Probes are 300 series stainless steel

Style RT1—Adjustable Tip

- RTD tip immersion length can be field adjusted from flush to 2"
- Eliminates excess inventory

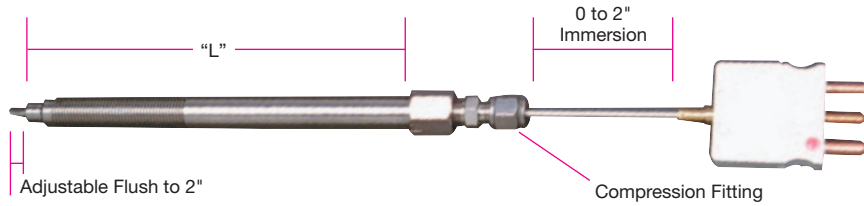

Part Number	
L = 3"	L = 6"
RTP00001	RTP00002

Style RT2—Rigid Plug Mount Fixed Tip

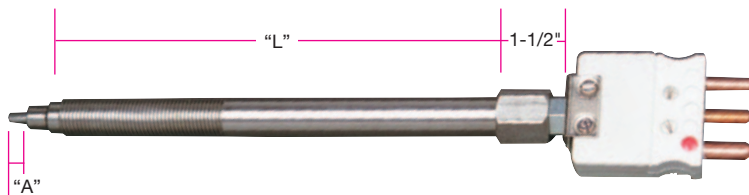

Part Number	"A" (in)	"L" (in)
RTP00003	Flush	3
RTP00004	1/4	3
RTP00005	1/2	3
RTP00006	3/4	3
RTP00007	1	3
RTP00008	Flush	6
RTP00009	1/4	6
RTP00010	1/2	6
RTP00011	3/4	6
RTP00012	1	6

Style RT3—Flexible Mounted Plug

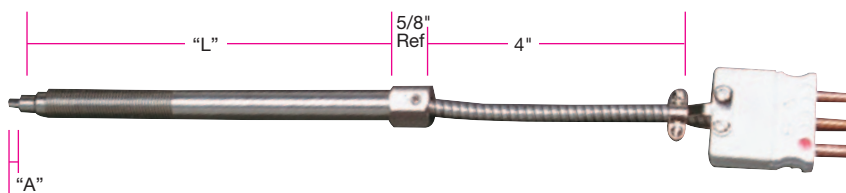

Part Number	"A" (in)	"L" (in)
RTP00013	Flush	3
RTP00014	1/4	3
RTP00015	1/2	3
RTP00016	3/4	3
RTP00017	1	3
RTP00018	Flush	6
RTP00019	1/4	6
RTP00020	1/2	6
RTP00021	3/4	6
RTP00022	1	6

Blank Melt Bolts

(See page 14-101)



Detailed Dimensions for Plastic Melt Bolts

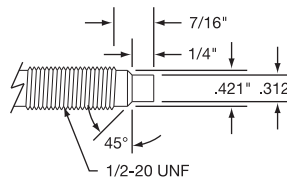

Bolt-Tip Dimensions

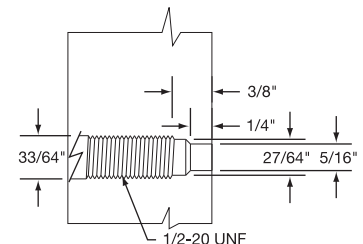

Recommended drilling dimensions for proper mounting in extruder barrel.

Thermistors

General Purpose NTC Thermistors

Design Features

- * 316 Stainless Steel Sheath
- * Glass Encapsulated Thermistor Element
- * Fast Response Time
- * Up to 572°F (300°C) Operating Temperature (Limited to Wire Insulating Material; See Box 8)

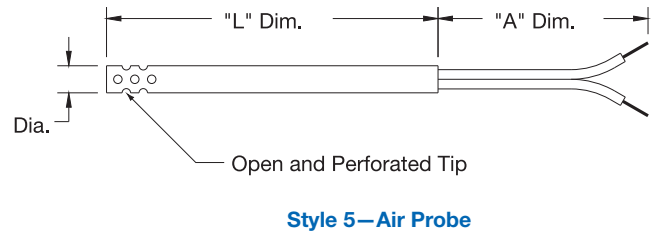
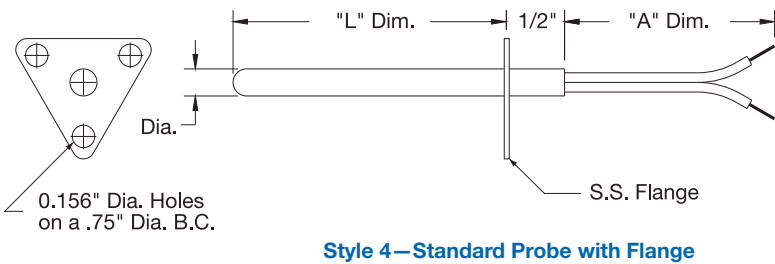
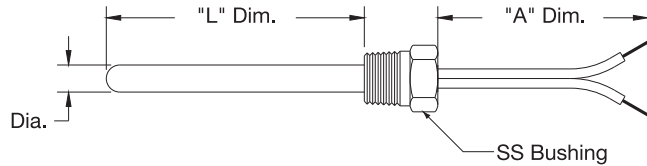
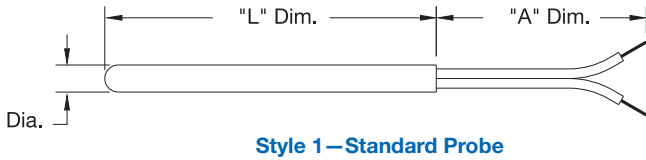

Ordering Code: **TTR** -

Style BOX 1
1 = Standard Probe
2 = Standard Probe with 1/8" NPT SS Bushing
3 = Standard Probe with 1/4" NPT SS Bushing
4 = Standard Probe with Flange
5 = Open Air
6 = Open Air with Flange

Diameter BOX 2
G = 0.188" Dia.
H = 0.250" Dia.
X = Other (Specify)

Element Resistance BOX 3
K = 10KΩ
L = 20KΩ
N = 50KΩ
P = 100KΩ
X = Other (Specify)

Resistance Tolerance BOX 4
 (At 25°C/77°F)
D = +/-10% (Standard)
C = +/-5%
B = +/-2%
A = +/-1%

"L" Dimension BOX 5
 Whole inches
01 to 99

"L" Dimension BOX 6
 Fractional inches
0 = 0" **3** = 3/8" **6** = 3/4"
1 = 1/8" **4** = 1/2" **7** = 7/8"
2 = 1/4" **5** = 5/8"

"A" Dimension BOX 7
 Whole inches
001 to 999

Lead Insulation BOX 8

		w/ SS Overbraid	w/ SS Armor Cable
Fiberglass 900°F (482°C)	S	B	A
Teflon® 392°F (200°C)	T	D	F

Termination BOX 9
B = No Termination **C** = Spade Lugs with BX Conn.
S = Spade Lugs **X** = Other (Specify)

Special Requirements BOX 10
X = Specify
0 = None

⚠ WARNING: Cancer and Reproductive Harm - www.P65Warnings.ca.gov.

Precision Centigrade Temperature Sensor

This sensor probe utilizes a dual precision integrated-circuit temperature sensor, whose output voltage is linearly proportional to the Celsius temperature.

This sensor does not require any external calibration or trimming to provide typical accuracies of $\pm 1/4^\circ\text{C}$ at room temperature or $\pm 3/4^\circ\text{C}$ over a full -55°C to 150°C temperature range. This sensor includes a Molex 4-pin connector.

Design Features:

- * Calibrated directly in $^\circ\text{C}$
- * Linear $+10.0\text{mv}/^\circ\text{C}$ scale factor
- * $\pm 1/4^\circ\text{C}$ accuracy (at 25°C)
- * Rated to full -55°C to 150°C range
- * Suitable for remote applications
- * Operates from 4 to 30 volts
- * Less than $60\mu\text{A}$ current drain
- * Low self-heating, 0.08°C in still air
- * Nonlinearity only $\pm 1/4^\circ\text{C}$ typical
- * Low impedance output, 0.1Ω for 1mA load

This Sensor is available in other designs and configurations. Consult Tempco with your requirements.

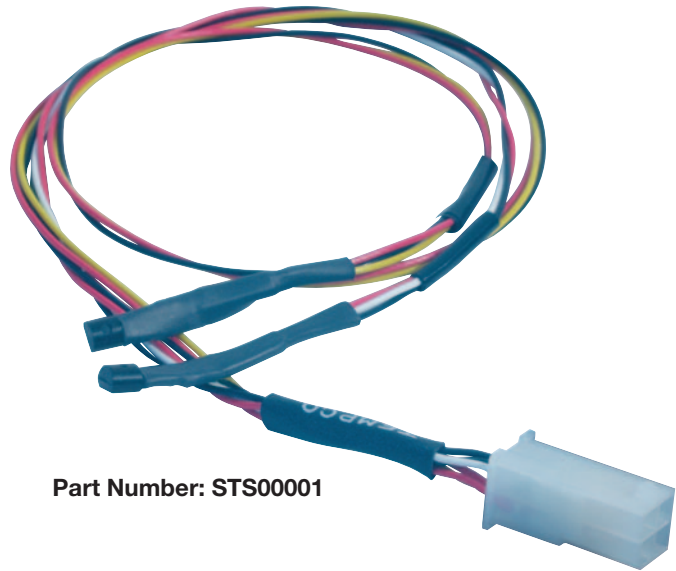

Part Number: STS00001

2000 Ohm RTD Sensor

This sensor probe is a fast responding 2000 ohm RTD sensor used widely in the HVAC, appliance and automotive industries. Sensor is protected in a 316 SS housing and supplied with 22 ga. Teflon® leads.

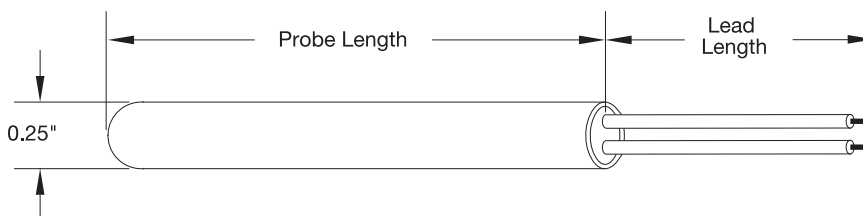
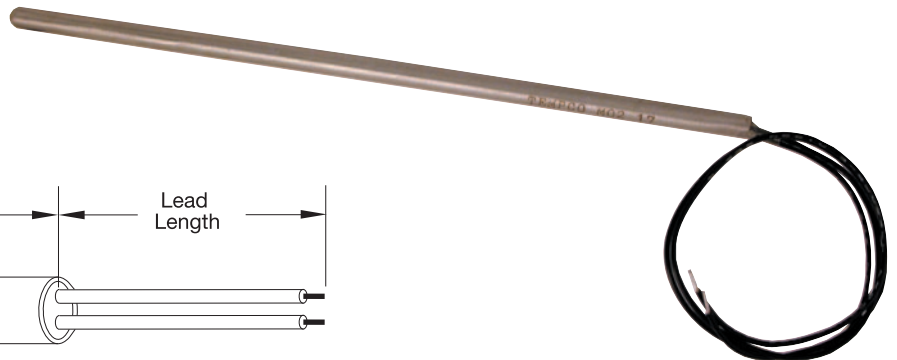

Design Features:

- * 2000 ohm nominal resistance at 20°C
- * Accurate to $\pm 0.7^\circ\text{C}$ at 20°C
- * Near linear temperature sensitivity; provides $8\Omega/^\circ\text{C}$ sensitivity
- * $\pm 3\%$ max. linearity (can be linearized to $\pm 0.2\%$)
- * Long term stability
- * Interchangeable without sensor-to-sensor recalibration
- * Operating temperature range of -40°C to $+150^\circ\text{C}$

Part Number	Probe Length	Lead Length
STS00002	8"	10-1/2"
STS00003	4"	13"

This type of sensor is also available in other designs and configurations. Consult Tempco with your requirements.

Special Application Thermocouples

Spring-Loaded Surface Contact Thermocouple

This Type J thermocouple is used to sense the temperature of moving drums or rollers. Spring-loaded tip provides free movement and proper contact of the sensing tip. The sensing tip is made of copper for fast response time. Thermocouple wires are terminated in a miniature connection head and connected to a terminal block. This thermocouple can be operated up to 500°F (260°C).

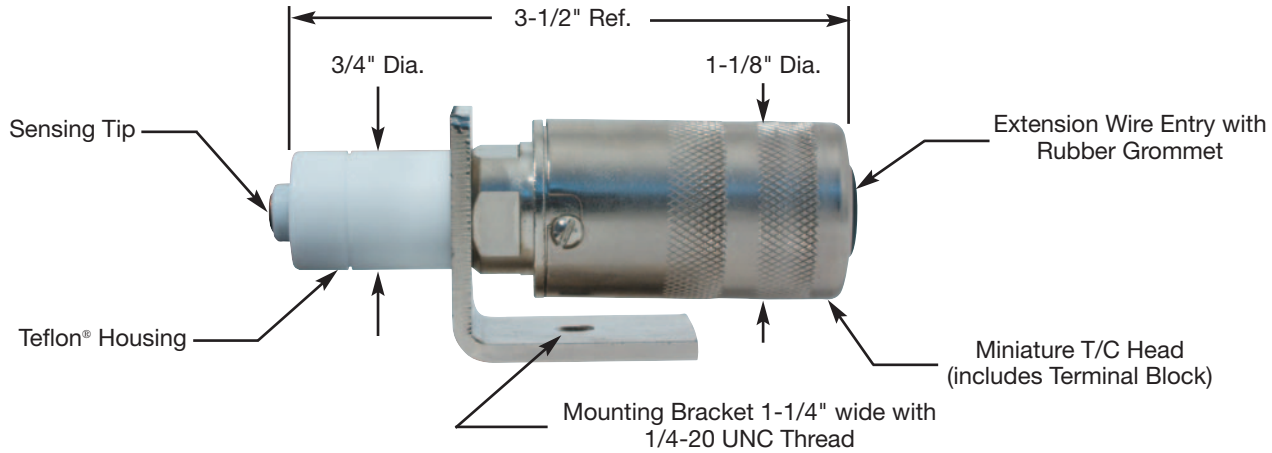

Part Number: TCP90185

Type J calibration; consult Tempco for other calibrations.

Compound Mixer Thermocouple

This Type J thermocouple is used in mixers and pelletizers. The body is made of 416 SS. The ungrounded junction, and sensing tip, is isolated from the body with a high temperature thermal barrier to ensure accuracy.

Maximum Operating Temperature: 750°F (400°C).

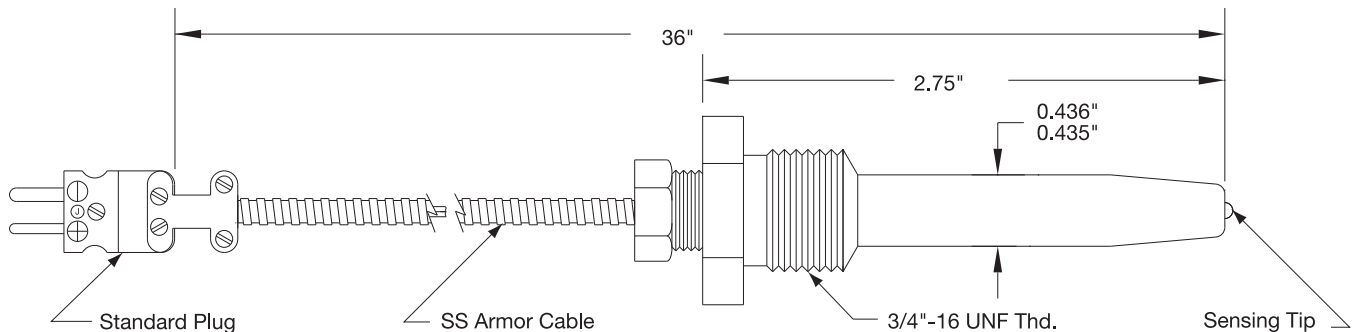
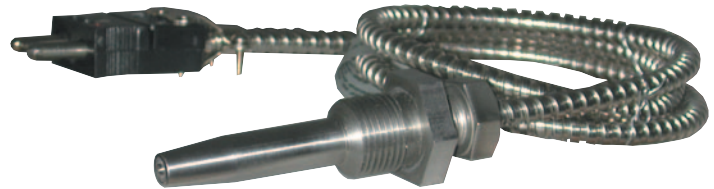

Part Number: TCP90231

10" Long Bezel Jack Panel for Standard Thermocouple Connectors

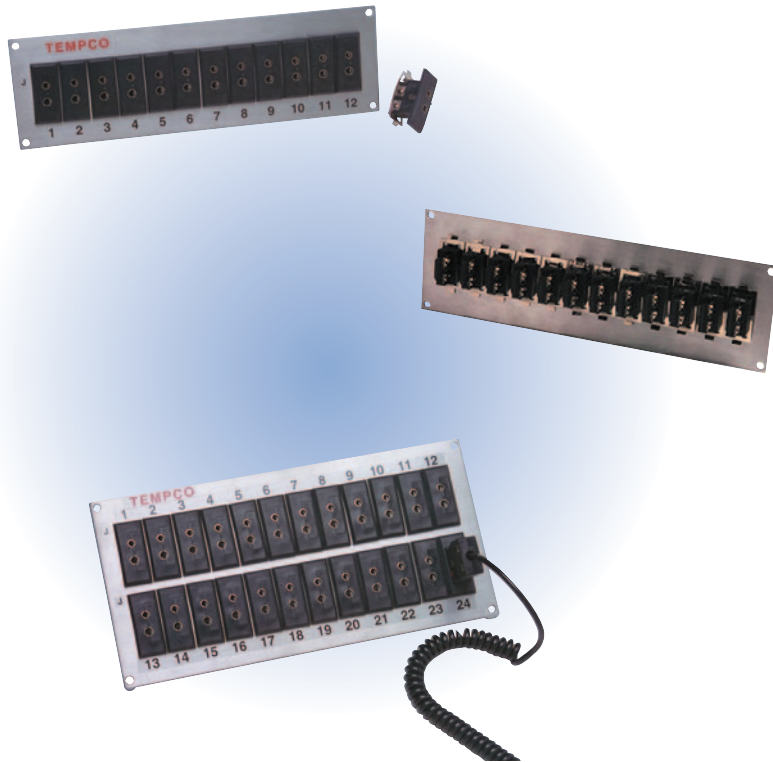

Design Features:

- * Accepts standard plugs.
- * Jacks are ANSI color coded, glass-filled nylon with a temperature rating of 350°F (177°C) continuous and 400°F (204°C) intermittent.
- * Panels are manufactured from rugged, .090" thick aluminum.
- * Brushed and anodized finishes are available at an additional cost. Consult TEMPCO with your requirements.
- * Panels are normally supplied unassembled with all necessary hardware to assemble and install included. Can be furnished assembled at an additional cost.

Standard Sizes

Part Number	Number of Rows	Panel Height H x L (in)	Number of Jacks	Cutout Size H x L (in)
JP(✚)00001	1	3½ x 10	12	1⅞ x 9¼
JP(✚)00002	2	5⅜ x 10	24	3⅜ x 9¼
JP(✚)00003	3	8⅞ x 10	36	6½ x 9¼
JP(✚)00004	4	9⅞ x 10	48	8¼ x 9¼
JP(✚)00005	5	12¾ x 10	60	11⅞ x 9¼
JP(✚)00006	6	14⅞ x 10	72	12⅞ x 9¼

- ✚ Insert calibration code (J, K, T, E, R, S, U) in Part Number, "U" is designated for RTDs and type B thermocouples



Notes: Mounting Hole Spacing: 3/16" in from each side to center of 13/64" hole (for #10 screw)

Bezel Panel Jacks are retained by a spring clip, which is installed from the rear of the panel.

Wire may be attached after jacks are installed in panel.

5-1/2" Long Bezel Jack Panel for Standard Thermocouple Connectors

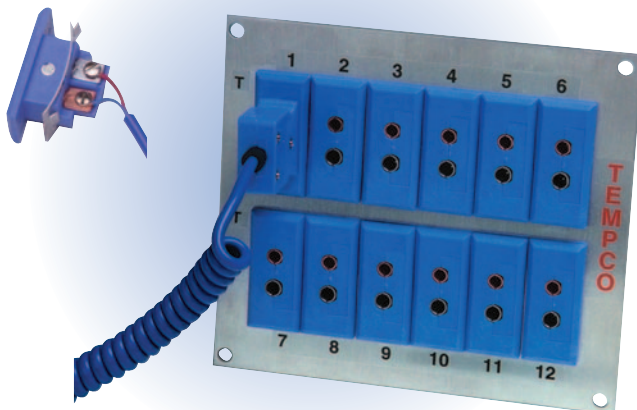

Standard Sizes

Part Number	Number of Rows	Panel Height H x L (in)	Number of Jacks	Cutout Size H x L (in)
JP(✚)00007	1	3½ x 5½	6	1⅞ x 4 ²¹ / ₃₂
JP(✚)00008	2	5⅜ x 5½	12	3⅜ x 4 ²¹ / ₃₂
JP(✚)00009	3	8⅞ x 5½	18	6½ x 4 ²¹ / ₃₂
JP(✚)00010	4	9⅞ x 5½	24	8¼ x 4 ²¹ / ₃₂
JP(✚)00011	5	12¾ x 5½	30	11⅞ x 4 ²¹ / ₃₂
JP(✚)00012	6	14⅞ x 5½	36	12⅞ x 4 ²¹ / ₃₂

- ✚ Insert calibration code (J, K, T, E, R, S, U) in Part Number, "U" is designated for RTDs and type B thermocouples

Jack Panels

Jack Panels for Miniature Thermocouple Connectors

Design Features:

- * Designed to be space saving.
- * Complements modern miniature instrumentation.
- * Jack bodies are ANSI color coded, glass-filled nylon with a temperature rating of 350°F (177°C) continuous and 400°F (204°C) intermittent.
- * Panels are manufactured of rugged .090" thick aluminum.
- * Brushed and anodized finishes are available at an additional cost. Consult TEMPCO with your requirements.
- * Panels are supplied unassembled for ease of wiring—all hardware necessary to assemble is included.

Standard Sizes

Part Number	Number of Rows	Panel Height H x L (in)	Number of Jacks	Cutout Size H x L (in)
JP(+)00013	1	2 ²¹ / ₃₂ x 3 ⁵ / ₈	6	1 ⁹ / ₃₂ x 3 ³ / ₃₂
JP(+)00014	2	4 ³ / ₁₆ x 3 ⁵ / ₈	12	2 ¹⁵ / ₁₆ x 3 ³ / ₃₂
JP(+)00015	3	5 ³¹ / ₃₂ x 3 ⁵ / ₈	18	4 ¹⁹ / ₃₂ x 3 ³ / ₃₂
JP(+)00016	4	7 ⁷ / ₈ x 3 ⁵ / ₈	24	6 ¹ / ₄ x 3 ³ / ₃₂
JP(+)00017	1	2 ²¹ / ₃₂ x 6 ⁵ / ₈	12	1 ⁹ / ₃₂ x 6 ¹ / ₁₆
JP(+)00018	2	4 ³ / ₁₆ x 6 ⁵ / ₈	24	2 ¹⁵ / ₁₆ x 6 ¹ / ₁₆
JP(+)00019	3	5 ³¹ / ₃₂ x 6 ⁵ / ₈	36	4 ¹⁹ / ₃₂ x 6 ¹ / ₁₆
JP(+)00020	4	7 ⁷ / ₈ x 6 ⁵ / ₈	48	6 ¹ / ₄ x 6 ¹ / ₁₆

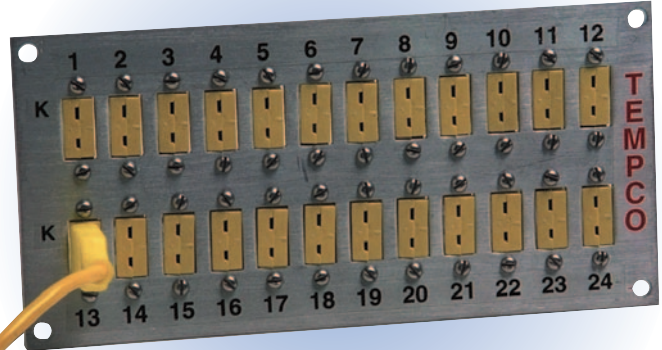

Note: Mounting Hole Spacing: 3/16" in from each side to center of 13/64" hole (for #10 screw)

- ✦ Insert calibration code (J, K, T, E, R, S, U) in Part Number, "U" is designated for RTDs and type B thermocouples

Ordering Information

Catalog Jack Panels

Order by Part Number

Custom Engineered/Manufactured Jack Panels

For sizes and styles not listed, TEMPCO will design and manufacture a Jack Panel to meet your specifications. **Standard lead time is 2 weeks.**

Please Specify the following:

- Overall Dimensions
- Type of Jack (Standard or Miniature)
- Number of Jacks (Circuits)
- Number of Rows
- Calibration

⚠ WARNING: Cancer and Reproductive Harm - www.P65Warnings.ca.gov.

Jack Panels for Standard 3-pin Connectors

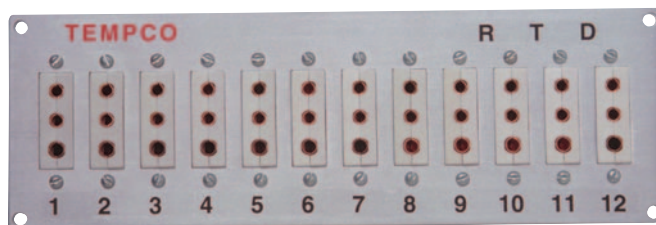

Standard Sizes

Part Number	Number of Rows	Panel Height H x L (in)	Number of Jacks	Cutout Size H x L (in)
JP(✚)00021	1	3½ x 5¼	6	2¾ x 4½
JP(✚)00022	2	6½ x 5¼	12	4¾ x 4½
JP(✚)00023	3	8½ x 5¼	18	7¾ x 4½
JP(✚)00024	4	11½ x 5¼	24	9¾ x 4½
JP(✚)00025	1	3½ x 9¾	12	2¾ x 8¾
JP(✚)00026	2	6½ x 9¾	24	4¾ x 8¾
JP(✚)00027	3	8½ x 9¾	36	7¾ x 8¾
JP(✚)00028	4	11½ x 9¾	48	9¾ x 8¾

✚ Insert calibration code (J, K, T, E, R, S, U) in Part Number, "U" is designated for RTDs and type B thermocouples.

Design Features:

- * For use with RTDs and shielded thermocouples requiring 3 wires.
- * Will accept standard 3-Pin connectors.
- * Jack bodies are ANSI color coded, glass-filled nylon with a temperature rating of 350°F (177°C) continuous and 400°F (204°C) intermittent.
- * Panels are manufactured of rugged .090" thick aluminum.
- * Brushed and anodized finishes are available at an additional cost. Consult TEMPCO with your requirements.
- * Panels are supplied unassembled for ease of wiring — all hardware necessary to assemble is included.



Note: Mounting Hole Spacing: 3/16" in from each side to center of 13/64" hole (for #10 screw)

Jack Panels for Miniature 3-Pin Connectors



Standard Sizes

Part Number	Number of Rows	Panel Height H x L (in)	Number of Jacks	Cutout Size H x L (in)
JP(✚)00029	1	2½ x 4¾	6	1¾ x 4¾
JP(✚)00030	2	4½ x 4¾	12	3¾ x 4¾
JP(✚)00031	3	6½ x 4¾	18	5¾ x 4¾
JP(✚)00032	4	8½ x 4¾	24	7¾ x 4¾
JP(✚)00033	1	2½ x 9	12	1¾ x 8¾
JP(✚)00034	2	4½ x 9	24	3¾ x 8¾
JP(✚)00035	3	6½ x 9	36	5¾ x 8¾
JP(✚)00036	4	8½ x 9	48	7¾ x 8¾

✚ Insert calibration code (J, K, T, E, R, S, U) in Part Number, "U" is designated for RTDs and type B thermocouples

Design Features:

- * For use with RTDs and shielded thermocouples requiring 3 wires.
- * Complements modern miniature instrumentation.
- * Jack bodies are ANSI color coded, glass-filled nylon with a temperature rating of 350°F (177°C) continuous and 400°F (204°C) intermittent.
- * Panels are manufactured of rugged .090" thick aluminum.
- * Brushed and anodized finishes are available at an additional cost. Consult TEMPCO with your requirements.
- * Panels are supplied unassembled for ease of wiring—all hardware necessary to assemble is included.



Note: Mounting Hole Spacing: 3/16" in from each side to center of 13/64" hole (for #10 screw)

Jack Panels

Jack Panels — Jab-In Style Termination

Design Features:

- * Accepts Standard Plugs.
- * Jacks will accept up to 14-gauge wire.
- * Jack bodies are ANSI color coded, glass-filled nylon with a temperature rating of 350°F (177°C) continuous and 400°F (204°C) intermittent.
- * Panels are manufactured of rugged .090" thick aluminum.
- * Brushed and anodized finishes are available at an additional cost. Consult TEMPCO with your requirements.
- * Jack rows are placed further apart than standard Jack Panels for ease of termination.
- * Panels are supplied unassembled for ease of wiring — all hardware necessary to assemble is included.

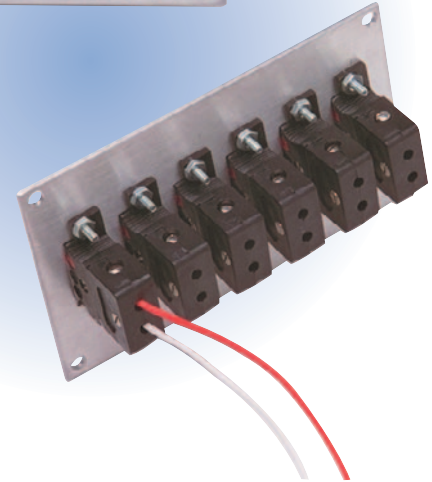
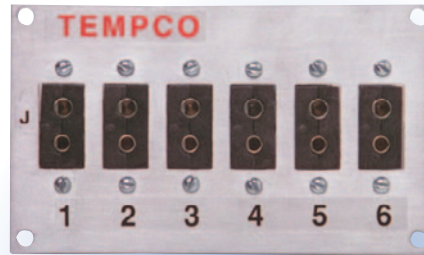

Standard Sizes

Part Number	Number of Rows	Panel Height H x L (in)	Number of Jacks	Cutout Size H x L (in)
JP(+)00037	1	3½ x 5½	6	1¾ x 4 ²¹ / ₃₂
JP(+)00038	2	5 ³ / ₁₆ x 5½	12	3 ³ / ₁₆ x 4 ²¹ / ₃₂
JP(+)00039	3	8 ¹ / ₈ x 5½	18	6 ¹ / ₂ x 4 ²¹ / ₃₂
JP(+)00040	1	3½ x 10	12	1¾ x 9¼
JP(+)00041	2	5 ³ / ₁₆ x 10	24	3 ³ / ₁₆ x 9¼
JP(+)00042	3	8 ¹ / ₈ x 10	36	6 ¹ / ₂ x 9¼

- * Insert calibration code (J, K, T, E, R, S, U) in Part Number, "U" is designated for RTDs and type B thermocouples



Note: Mounting Hole Spacing: 3/16" in from each side to center of 13/64" hole (for #10 screw).

To help ease installation:
Optional Ratchet Screwdriver

Part Number:
TUL-101-101



Ordering Information

Catalog Jack Panels
Order by Part Number

Custom Engineered/Manufactured Jack Panels

For sizes and styles not listed, TEMPCO will design and manufacture a Jack Panel to meet your specifications. **Standard lead time is 2 weeks.**

Please Specify the following:

- Overall Dimensions
- Type of Jack (Standard or Miniature)
- Number of Jacks (Circuits)
- Number of Rows
- Calibration

WARNING: Cancer and Reproductive Harm - www.P65Warnings.ca.gov.

Thermocouple and RTD Selector Switch

Design Features:

- * Available in 6 to 36 positions.
- * 2-pole and 3-pole circuits with "OFF" position.
- * Silver-plated blades and contacts with self-cleaning wiper action and low contact resistance.
- * Terminals are silver-plated brass with numbered circuits and polarity identification.
- * "OFF" position has terminals available for shorting input circuit when using it with a digital meter (not available on 3-pole).
- * High-impact GE Noryl™ case.

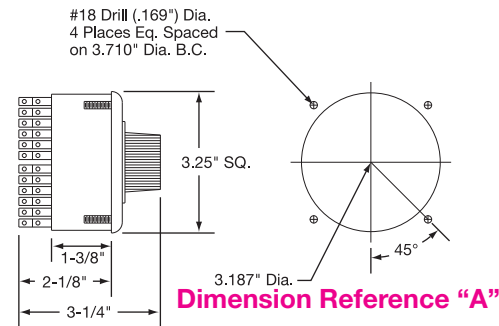

Number of Positions	Circuit Type	Dimensions Reference	Part Number
6	2-Pole	A	TCA-124-101
10	Break Before Make	A	TCA-124-102
12	2-Pole	A	TCA-124-103
18	Make Before Break	A	TCA-124-104
20	Make Before Break	A	TCA-124-105
24	2-Pole	B	TCA-124-106
36	Make Before Break	B	TCA-124-107
6	3-Pole	B	TCA-124-108
12	3-Pole	B	TCA-124-109
18	Make Before Break	B	TCA-124-110
24	Make Before Break	B	TCA-124-111

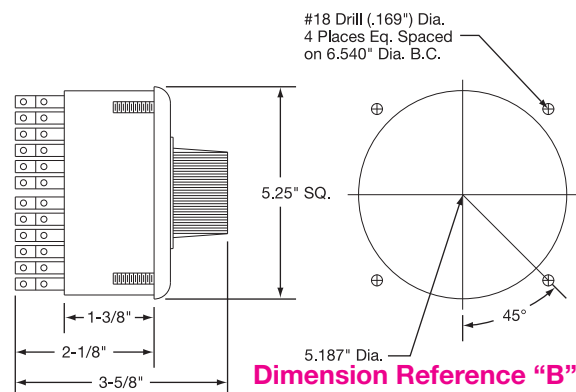

Circular Panel Jacks

Design Features:

- * Available in standard and miniature sizes (2-pin only).
- * Used where individual jacks are required to fit in standard electrical knockouts.
- * Standard jack fits in 3/4" (1-1/8" dia.) electrical knockout.
- * Miniature jack fits in 1/2" (7/8" dia.) electrical knockout.
- * Jacks are ANSI color coded with a temperature rating of 350°F (177°C) continuous and 400°F (204°C) intermittent.
- * Both the standard and miniature jacks install from the front of the panel with no additional hardware required.

Standard Jack



Miniature Jack



ANSI Calibration	Body Color	Part Number	
		Standard	Miniature
J	Black	TCA-102-167	TCA-102-174
K	Yellow	TCA-102-168	TCA-102-175
T	Blue	TCA-102-169	TCA-102-176
E	Purple	TCA-102-170	TCA-102-177
R/S	Green	TCA-102-171	TCA-102-178
U*	White	TCA-102-172	TCA-102-179
N	Orange	TCA-102-173	—

* "U" is designated for RTDs and type B thermocouples

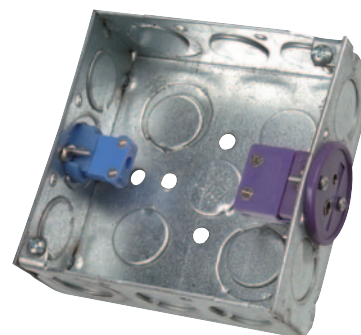

Example of Electrical Box Mount



Jack Panels

Jack Panels

Panel Only

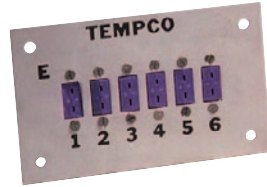

Panel and Box Assembly

For FS Box

Design Features:

- * Jack Panels are designed to be used with standard FS Style boxes.
- * Panels are manufactured of rugged .090" thick aluminum.
- * Panels are designed to accept the safest maximum number of Jacks.
- * Available for Standard and Miniature Jacks, 2-pin or 3-pin.
- * Rated for 350°F (177°C) continuous and 400°F (204°C) intermittent.
- * Panels measure 2-13/16" high × 4-1/2" long.

Jack Style	Number of Jacks	Part Number	
		Panel Only	Panel and Box Assembly
Standard 2-Pin Bezel Mount	4	JP(+)00043	JP(+)00060
Standard 2-Pin Jab-In Mount	4	JP(+)00044	JP(+)00062
Standard 3-Pin	4	JP(+)00045	JP(+)00063
Miniature 2-Pin	6	JP(+)00046	JP(+)00059
Miniature 3-Pin	4	JP(+)00047	JP(+)00064

+ Insert calibration code (J, K, T, E, R, S, U) in Part Number, "U" is designated for RTDs and type B thermocouples

Custom-Made 19" Rack Panels

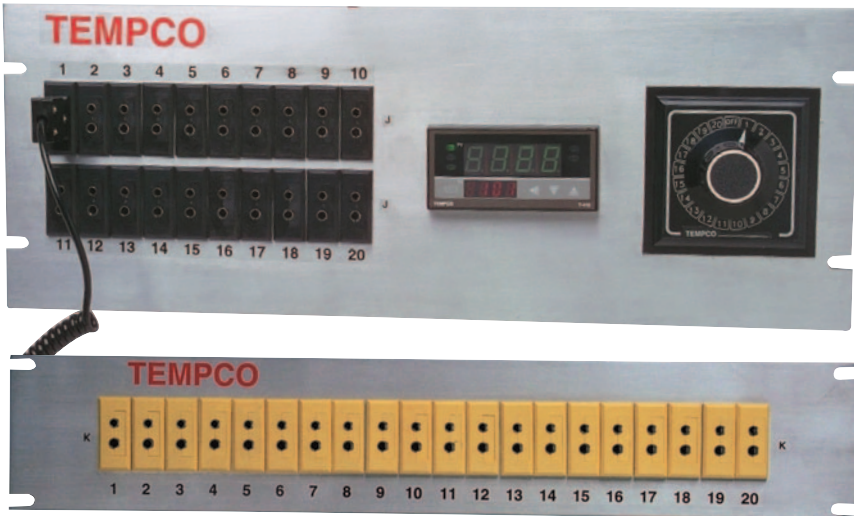

Design Features:

- * Panels are made of .090" thick aluminum with a smooth mill finish.
- * All panels have slotted holes positioned at E.I.A. standard spacing.
- * Panels are available with any of the standard or miniature Panel Jacks shown in this section.
- * Rack Panels come in standard heights of 3-1/2", 5-1/4", 7", and 8-1/4".
- * Panels are supplied unassembled for ease of wiring—all hardware to assemble is included.

Ordering Information

Custom Engineered/Manufactured Rack Panels

TEMPCO can manufacture a Rack Panel to meet your specifications. **Standard lead time is 2 weeks.**

Please Specify the following:

Rack Panels are custom made.

- | | |
|---|---|
| <input type="checkbox"/> Panel Size | <input type="checkbox"/> Calibration(s) |
| <input type="checkbox"/> Type of Jack (Standard or Miniature) | <input type="checkbox"/> Panel Meter Style |
| <input type="checkbox"/> Number of Jacks (circuits) | <input type="checkbox"/> Switch—if required |
| <input type="checkbox"/> Number of Rows | |

⚠ WARNING: Cancer and Reproductive Harm - www.P65Warnings.ca.gov.

Panel Jacks — Standard and Miniature

Bezel Mount Standard Jack

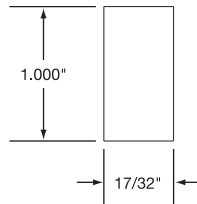

ANSI Calibration	Body Color	Part Number
J	Black	TCA-102-137
K	Yellow	TCA-102-138
T	Blue	TCA-102-139
E	Purple	TCA-102-140
R/S	Green	TCA-102-141
U*	White	TCA-102-142
N	Orange	TCA-102-180

Miniature 2-Pin Panel Jack

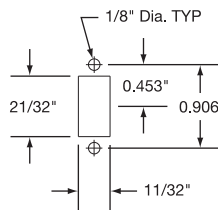

ANSI Calibration	Body Color	Part Number
J	Black	TCA-102-143
K	Yellow	TCA-102-144
T	Blue	TCA-102-145
E	Purple	TCA-102-146
R/S	Green	TCA-102-147
U*	White	TCA-102-148

Standard 3-Pin Panel Jack

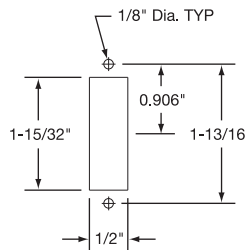

ANSI Calibration	Body Color	Part Number
J	Black	TCA-102-149
K	Yellow	TCA-102-150
T	Blue	TCA-102-151
E	Purple	TCA-102-152
R/S	Green	TCA-102-153
U*	White	TCA-102-154

Miniature 3-Pin Panel Jack

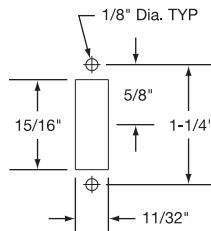

ANSI Calibration	Body Color	Part Number
J	Black	TCA-102-155
K	Yellow	TCA-102-156
T	Blue	TCA-102-157
E	Purple	TCA-102-158
R/S	Green	TCA-102-159
U*	White	TCA-102-160

Panel Mount Standard Jab-In Jack

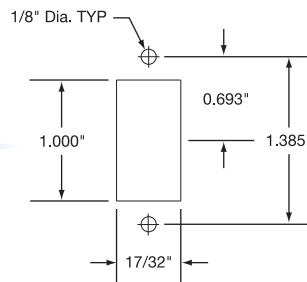
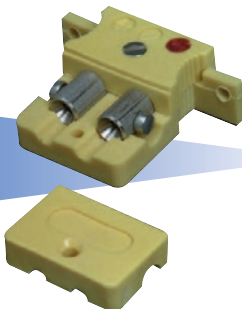

ANSI Calibration	Body Color	Part Number
J	Black	TCA-102-161
K	Yellow	TCA-102-162
T	Blue	TCA-102-163
E	Purple	TCA-102-164
R/S	Green	TCA-102-165
U*	White	TCA-102-166



Note: All panel jacks have the same high quality features as their non-panel counterparts and include hardware for mounting.

* "U" is designated for RTDs and type B thermocouples

Panel Jacks are rated for 350°F (177°C) continuous and 400°F (204°C) intermittent.

Standard Thermowells for Industrial Applications



Velocity Ratings of Wells

Well failures, in most cases, are not due to the effects of pressure and temperature. The calculations necessary to provide adequate strength under given conditions are familiar enough to permit proper choice of wall thickness and material.

Less familiar, and more dangerous, are the vibrational effects to which wells are subjected. Fluid, flowing by the well, forms a turbulent wake (called the Von Karman Trail) which has a definite frequency based on the diameter of the well and the velocity of the fluid. It is important that the well has sufficient stiffness so that the wake frequency will never equal the natural frequency of the well itself. If the natural frequency of the well were to coincide with the wake frequency, the well would vibrate to destruction and break off in the piping.

On the following pages, a recommended velocity rating can be found for every standard well length and material cataloged. To reduce the complexity of presenting this information, the ratings are based on operating temperatures of 1000°F for wells made of Carbon Steel (C-1018), ANSI 304, and ANSI 316. Values for Brass wells are based on 350°F operation. Limits for Monel are based on 900°F service. Slightly higher velocity is possible at lower temperatures.

Where single values appear in the velocity tables, these may be considered safe for water, steam, air or gas. In the shorter insertion lengths, consideration is given to the velocity pressure effect of water flowing at higher velocities. The values in parentheses, therefore, represent safe values for water flow, while the unbracketed value may be used for steam, air, gas and fluids of similar density.

It should be pointed out that the values given are extremely conservative, and intended primarily as a guide. Wells are also safe if the resonant frequency is well below the wake frequency or if the fluid velocity is constantly fluctuating through the critical velocity point. Nevertheless, if the installation is not hampered by the use of a sufficiently stiff well, we recommend the values should not be exceeded.

If you have operating conditions requiring special well designs, our engineering staff is available to assist you. Consult Tempco with your requirements.

Series 10 Straight Shank with .260 Bore for 1/4" Diameter Elements

Standard Duty Threaded

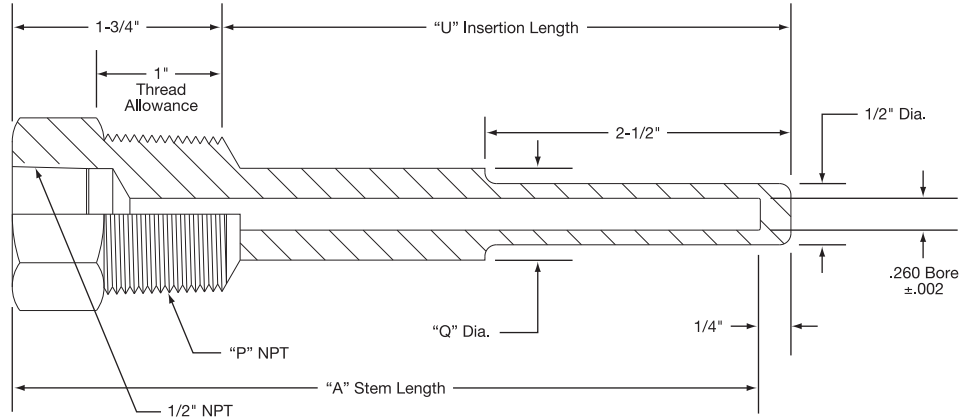

Ordering Information

Complete the Part Number by filling in the box with the number designating the material.

- 1** = Steel
- 2** = Brass
- 3** = 316 Stainless Steel
- 4** = 304 Stainless Steel
- 5** = Monel

Standard Sizes

Part Number	External Thread "P"	Stem Length "A" (in)	Insertion Length "U" (in)	Shank Diameter "Q" (in)
TWL1011	1/2" NPT	4	2 1/2	—
TWL1012		6	4 1/2	3/8
TWL1013		9	7 1/2	5/8
TWL1014		12	10 1/2	5/8
TWL1015		15	13 1/2	5/8
TWL1016		18	16 1/2	5/8
TWL1018		24	22 1/2	5/8
TWL1021	3/4" NPT	4	2 1/2	—
TWL1022		6	4 1/2	3/4
TWL1023		9	7 1/2	3/4
TWL1024		12	10 1/2	3/4
TWL1025		15	13 1/2	3/4
TWL1026		18	16 1/2	3/4
TWL1028		24	22 1/2	3/4
TWL1031	1" NPT	4	2 1/2	—
TWL1032		6	4 1/2	7/8
TWL1033		9	7 1/2	7/8
TWL1034		12	10 1/2	7/8
TWL1035		15	13 1/2	7/8
TWL1036		18	16 1/2	7/8
TWL1037		24	22 1/2	7/8
TWL1038		24	22 1/2	7/8

Maximum Fluid Velocity, Feet Per Second

(See Velocity Ratings on page 14-76)

Well Type	Material	Insertion Length — "U" (in)							
		2 1/2	4 1/2	7 1/2	10 1/2	13 1/2	16 1/2	19 1/2	22 1/2
1/2" Series 10 and 15	Brass	207 (59.3)	75.5 (32.2)	27.3 (19.7)	13.9	8.4	5.6	4.1	3.0
	Carbon Steel	290 (106)	105 (59)	38.2 (36.3)	19.4	11.8	7.8	5.7	4.2
	A.I.S.I. 304 & 316	300 (148)	109 (82.2)	39.5	20.1	12.2	8.1	5.9	4.4
	Monel	261 (118)	95 (65.5)	34.4	17.5	10.5	7.1	5.2	3.8
3/4" Series 10 and 15	Brass	207 (59.3)	89.1 (39.8)	32.2 (23.9)	16.4	9.9	6.6	4.8	3.6
	Carbon Steel	290 (106)	123 (71.2)	44.9 (42.7)	22.8	13.8	9.3	6.7	4.9
	A.I.S.I. 304 & 316	300 (148)	128 (99.3)	46.4	23.6	14.3	9.6	6.9	5.1
	Monel	261 (118)	112 (79.8)	40.6	20.7	12.4	8.3	6.1	4.5
1" Series 10 and 15	Brass	207 (59.3)	102 (47.6)	37.0 (28)	18.8	11.4	7.6	5.5	4.1
	Carbon Steel	290 (106)	143 (84.3)	51.6 (50.6)	26.2	15.9	10.6	7.6	5.7
	A.I.S.I. 304 & 316	300 (148)	148 (117)	53.5	27.2	16.5	11.0	7.9	5.9
	Monel	261 (118)	128 (93.3)	46.7	23.7	14.4	9.5	6.9	5.1



Note: Where single values appear in table, thermowell may be considered safe for water, steam, air or gas. The values in parentheses in the shorter insertion lengths represent safe values for water flow, taking into consideration the velocity pressure effect of water flowing at higher velocities.

* See Page 14-78 for Maximum Pressure — Temperature Ratings *

WARNING: Cancer and Reproductive Harm - www.P65Warnings.ca.gov.

(800) 323-6859 • Email: sales@tempco.com

Series 15 Straight Shank — Lagging Extension Type with .260" Bore for 1/4" Diameter Elements Standard Duty Threaded



Ordering Information

Complete the Part Number by filling in the box with the number designating the material.

- 1 = Steel**
- 2 = Brass**
- 3 = 316 Stainless Steel**
- 4 = 304 Stainless Steel**
- 5 = Monel**

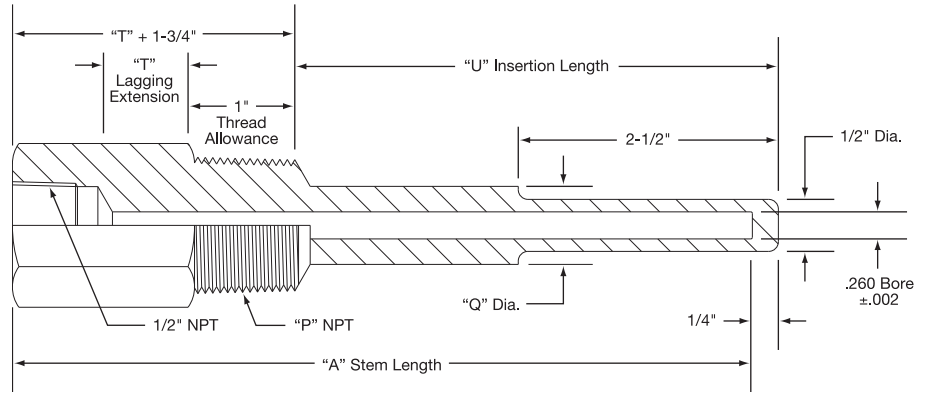

Standard Sizes

Part Number	External Thread "P"	Stem Length "A" (in)	Insertion Length "U" (in)	Lag Extension "T" (in)	Shank Diameter "Q" (in)
TWL1511 <input type="checkbox"/>	1/2" NPT	6	2 1/2	2	—
TWL1512 <input type="checkbox"/>		9	4 1/2	3	5/8
TWL1513 <input type="checkbox"/>		12	7 1/2	3	5/8
TWL1514 <input type="checkbox"/>		15	10 1/2	3	5/8
TWL1515 <input type="checkbox"/>		18	13 1/2	3	5/8
TWL1517 <input type="checkbox"/>		24	19 1/2	3	5/8
TWL1521 <input type="checkbox"/>	3/4" NPT	6	2 1/2	2	—
TWL1522 <input type="checkbox"/>		9	4 1/2	3	3/4
TWL1523 <input type="checkbox"/>		12	7 1/2	3	3/4
TWL1524 <input type="checkbox"/>		15	10 1/2	3	3/4
TWL1525 <input type="checkbox"/>		18	13 1/2	3	3/4
TWL1527 <input type="checkbox"/>		24	19 1/2	3	3/4
TWL1531 <input type="checkbox"/>	1" NPT	6	2 1/2	3	—
TWL1532 <input type="checkbox"/>		9	4 1/2	3	7/8
TWL1533 <input type="checkbox"/>		12	7 1/2	3	7/8
TWL1534 <input type="checkbox"/>		15	10 1/2	3	7/8
TWL1535 <input type="checkbox"/>		18	13 1/2	3	7/8
TWL1537 <input type="checkbox"/>		24	19 1/2	3	7/8

Pressure — Temperature Rating (lbs. per square inch)

Material	Temperature						
	70°F	200°F	400°F	600°F	800°F	1000°F	1200°F
Brass	5000	4222	1000	—	—	—	—
Carbon Steel	5200	5000	4800	4600	3500	1500	—
A.I.S.I. 304	7000	6200	5600	5400	5200	4500	1650
A.I.S.I. 316	7000	7000	6400	6200	6100	5100	2500
Monel	6500	6000	5400	5300	5200	1500	—

See Page 14-77 for Maximum Fluid Velocity, Feet Per Second

⚠ WARNING: Cancer and Reproductive Harm - www.P65Warnings.ca.gov.



Series 20 Tapered Shank with .260" Bore for 1/4" Diameter Elements

Heavy Duty Threaded

Series 20 Standard Sizes

Part Number	External Thread "P"	Element Length "A" (in)	Insertion Length "U" (in)	Shank Diameter "B" (in)
TWL2021	3/4" NPT	4	2 1/2	—
TWL2022		6	4 1/2	7/8
TWL2023		9	7 1/2	7/8
TWL2024		12	10 1/2	7/8
TWL2025		15	13 1/2	7/8
TWL2026		18	16 1/2	7/8
TWL2028	24	22 1/2	7/8	
TWL2031	1" NPT	4	2 1/2	—
TWL2032		6	4 1/2	1 1/16
TWL2033		9	7 1/2	1 1/16
TWL2034		12	10 1/2	1 1/16
TWL2035		15	13 1/2	1 1/16
TWL2036		18	16 1/2	1 1/16
TWL2038	24	22 1/2	1 1/16	

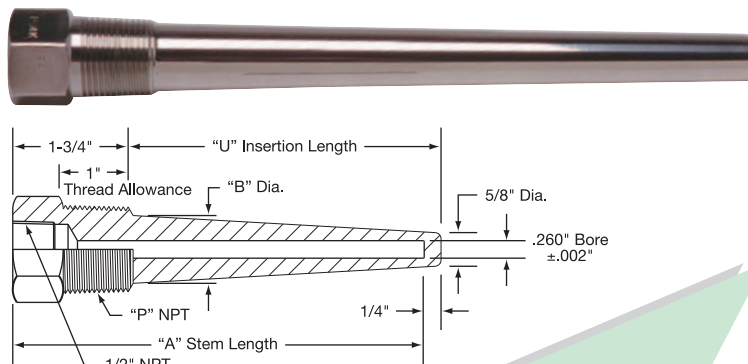

Thermowells are available in the following materials: Steel, Brass, 316 Stainless Steel, 304 Stainless Steel and Monel.

For Ordering Information See Page 14-78

Series 25 Tapered Shank-Lagging Extension Type with .260" Bore for 1/4" Diameter Elements

Heavy Duty Threaded

Series 25 Standard Sizes

Part Number	External Thread "P"	Lagging Extension "T" (in)	Stem Length "A" (in)	Insert Length "U" (in)	Shank Diameter "B" (in)
TWL2521	3/4" NPT	2	6	2 1/2	—
TWL2522		3	9	4 1/2	7/8
TWL2523		3	12	7 1/2	7/8
TWL2524		3	15	10 1/2	7/8
TWL2525		3	18	13 1/2	7/8
TWL2527		3	24	19 1/2	7/8
TWL2531	1" NPT	2	6	2 1/2	—
TWL2532		3	9	4 1/2	1 1/16
TWL2533		3	12	7 1/2	1 1/16
TWL2534		3	15	10 1/2	1 1/16
TWL2535		3	18	13 1/2	1 1/16
TWL2537		3	24	19 1/2	1 1/16

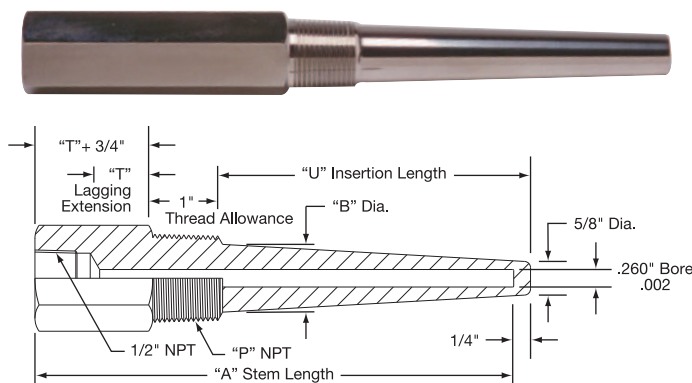

Maximum Fluid Velocity Feet Per Second (See Velocity Ratings on page 14-76)

Well Type	Material	Insertion Length — "U" (in)							
		2 1/2	4 1/2	7 1/2	10 1/2	13 1/2	16 1/2	19 1/2	22 1/2
3/4" Series 20 and 25	Brass	305 (97.5)	93.8 (54.1)	33.9	17.1	10.5	7.0	5.0	3.7
	Carbon Steel	386 (175)	180 (97.2)	65.3 (58.3)	33.0	20.1	13.4	9.6	7.1
	A.I.S.I. 304 & 316	440 (243)	197 (135)	71.2	36.0	22.0	14.7	10.5	7.8
	Monel	354 (195)	155 (108)	56.1	28.4	17.3	11.6	7.5	5.6
1" Series 20 and 25	Brass	354 (161)	108 (89.5)	39.4	19.8	12.2	8.1	5.8	4.3
	Carbon Steel	448 (289)	209 (161)	75.7	38.4	23.3	15.5	11.1	8.2
	A.I.S.I. 304 & 316	490 (403)	228 (225)	82.5	41.8	25.5	17.1	12.2	9.1
	Monel	410 (322)	179 (178)	65.1	33.0	20.1	13.5	8.7	6.5



Note: Where single values appear in table, thermowell may be considered safe for water, steam, air or gas. The values in parentheses in the shorter insertion lengths represent safe values for water flow, taking into consideration the velocity pressure effect of water flowing at higher velocities.

Pressure — Temperature Rating (lbs. per square inch)

Material	Temperature						
	70°F	200°F	400°F	600°F	800°F	1000°F	1200°F
Brass	5300	4750	1100	—	—	—	—
Carbon Steel	5950	5750	5450	5250	4000	1750	—
A.I.S.I. 304	7800	7050	6400	6150	6000	5190	1875
A.I.S.I. 316	7800	7800	7250	7100	6950	5800	2720
Monel	7450	6850	6150	6100	5940	1750	—

Thermowells

Series 30 Straight Shank with .385" Bore for 3/8" Diameter Elements

Standard Duty Threaded

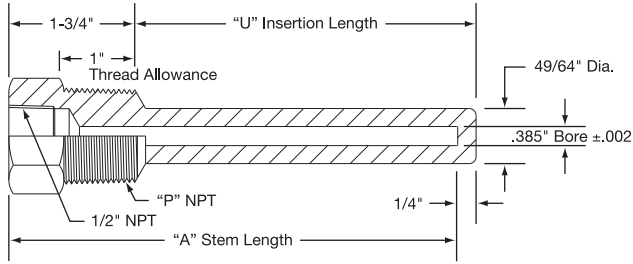

Series 30 Standard Sizes

Part Number	External Thread "P"	Stem Length "A" (in)	Insertion Length "U" (in)
TWL3021	3/4" NPT	4	2 1/2
TWL3022		6	4 1/2
TWL3023		9	7 1/2
TWL3024		12	10 1/2
TWL3025		15	13 1/2
TWL3026		18	16 1/2
TWL3028		24	22 1/2
TWL3031	1" NPT	4	2 1/2
TWL3032		6	4 1/2
TWL3033		9	7 1/2
TWL3034		12	10 1/2
TWL3035		15	13 1/2
TWL3036		18	16 1/2
TWL3038		24	22 1/2

Series 35 Straight Shank — Lagging Extension Type with .385" Bore for 3/8" Diameter Elements

Standard Duty Threaded

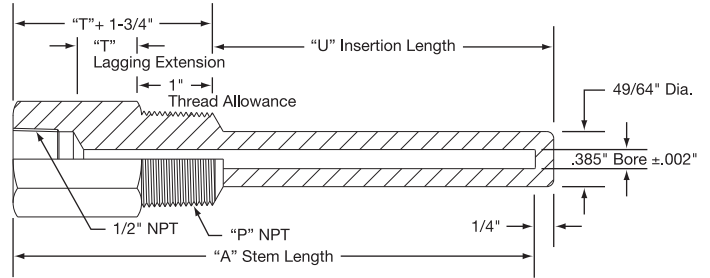

Series 35 Standard Sizes

Part Number	External Thread "P"	Lagging Extension "T" (in)	Stem Length "A" (in)	Insert Length "U" (in)
TWL3521	3/4" NPT	2	6	2 1/2
TWL3522		3	9	4 1/2
TWL3523		3	12	7 1/2
TWL3524		3	15	10 1/2
TWL3525		3	18	13 1/2
TWL3527		3	24	19 1/2
TWL3531		1" NPT	2	6
TWL3532	3		9	4 1/2
TWL3533	3		12	7 1/2
TWL3534	3		15	10 1/2
TWL3535	3		18	13 1/2
TWL3537	3		24	19 1/2

Thermowells are available in the following materials:
Steel, Brass, 316 Stainless Steel, 304 Stainless Steel and Monel.

For Ordering Information See Page 14-78

Pressure — Temperature Rating (lbs. per square inch)

Material	Temperature						
	70°F	200°F	400°F	600°F	800°F	1000°F	1200°F
Brass	5000	4222	1000	—	—	—	—
Carbon Steel	5200	5000	4800	4600	3500	1500	—
A.I.S.I. 304	7000	6200	5600	5400	5200	4500	1650
A.I.S.I. 316	7000	7000	6400	6200	6100	5100	2500
Monel	6500	6000	5400	5300	5200	1500	—

Maximum Fluid Velocity Feet Per Second

(See Velocity Ratings on page 14-76)

Material	Insertion Length — "U" (in)							
	2 1/2	4 1/2	7 1/2	10 1/2	13 1/2	16 1/2	19 1/2	22 1/2
Brass	290 (145)	150 (80)	54.1 (48)	27.6	16.7	11.1	8.0	6.0
Carbon Steel	326 (260)	192 (144)	69.5	35.4	20.5	14.3	10.3	7.7
A.I.S.I. 304 & 316	349 (360)	199	71.9	36.6	21.2	14.8	10.7	8.0
Monel	316 (320)	189 (178)	68.1	34.8	20.8	14.0	10.0	7.5



Note: Where single values appear in table, thermowell may be considered safe for water, steam, air or gas. The values in parentheses in the shorter insertion lengths represent safe values for water flow, taking into consideration the velocity pressure effect of water flowing at higher velocities.

Series 40 Tapered Shank with .385" Bore for 3/8" Diameter Elements

Heavy Duty Threaded

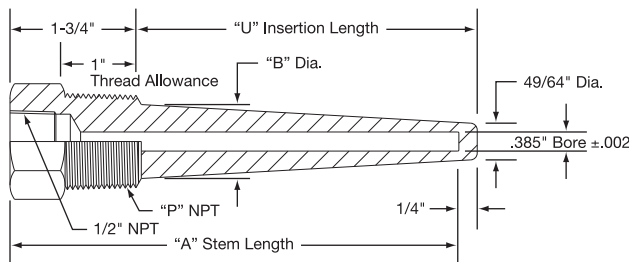

Series 40 Standard Sizes

Part Number	External Thread "P"	Stem Length "A" (in)	Insertion Length "U" (in)	Shank Diameter "B" (in)
TWL4021	3/4" NPT	4	2 1/2	7/8
TWL4022		6	4 1/2	7/8
TWL4023		9	7 1/2	7/8
TWL4024		12	10 1/2	7/8
TWL4025		15	13 1/2	7/8
TWL4026		18	16 1/2	7/8
TWL4028		24	22 1/2	7/8
TWL4031		1" NPT	4	2 1/2
TWL4032	6		4 1/2	1 1/16
TWL4033	9		7 1/2	1 1/16
TWL4034	12		10 1/2	1 1/16
TWL4035	15		13 1/2	1 1/16
TWL4036	18		16 1/2	1 1/16
TWL4038	24		22 1/2	1 1/16

Series 45 Tapered Shank — Lagging Extension Type with .385" Bore for a 3/8" Diameter Element

Heavy Duty Threaded

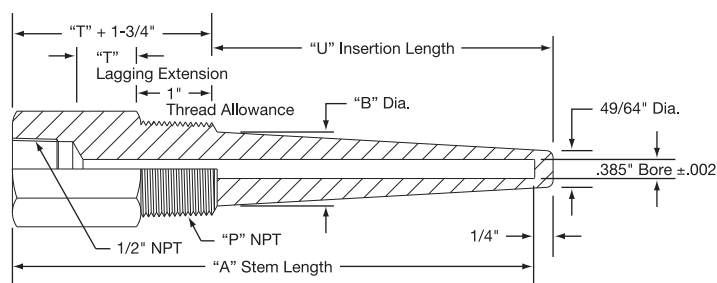

Series 45 Standard Sizes

Part Number	External Thread "P"	Lag. Exten. "T" (in)	Stem Length "A" (in)	Insert Length "U" (in)	Shank Diameter "B" (in)	
TWL4521	3/4" NPT	2	6	2 1/2	7/8	
TWL4522		3	9	4 1/2	7/8	
TWL4523		3	12	7 1/2	7/8	
TWL4524		3	15	10 1/2	7/8	
TWL4525		3	18	13 1/2	7/8	
TWL4527		3	24	19 1/2	7/8	
TWL4531		1" NPT	2	6	2 1/2	1 1/16
TWL4532			3	9	4 1/2	1 1/16
TWL4533	3		12	7 1/2	1 1/16	
TWL4534	3		15	10 1/2	1 1/16	
TWL4535	3		18	13 1/2	1 1/16	
TWL4537	3		24	19 1/2	1 1/16	

Thermowells are available in the following materials: Steel, Brass, 316 Stainless Steel, 304 Stainless Steel and Monel.

For Ordering Information See Page 14-78

Pressure — Temperature Rating (lbs. per square inch)

Material	Temperature						
	70°F	200°F	400°F	600°F	800°F	1000°F	1200°F
Brass	5000	4222	1000	—	—	—	—
Carbon Steel	5200	5000	4800	4600	3500	1500	—
A.I.S.I. 304	7000	6200	5600	5400	5200	4500	1650
A.I.S.I. 316	7000	7000	6400	6200	6100	5100	2500
Monel	6500	6000	5400	5300	5200	1500	—

Maximum Fluid Velocity Feet Per Second

(See Velocity Ratings on page 14-76)

Well Type	Material	Insertion Length — "U" (in)							
		2 1/2	4 1/2	7 1/2	10 1/2	13 1/2	16 1/2	19 1/2	22 1/2
3/4" Series 40 and 45	Brass	276 (127)	124 (79)	44.0	22.0	13.0	8.0	6.0	4.0
	Carbon Steel	352 (228)	191 (114)	68.9	35.0	21.0	14.0	10.0	7.5
	A.I.S.I. 304 & 316	415 (299)	203 (154)	73.2	37.3	22.5	15.0	11.0	8.0
	Monel	340 (255)	172 (134)	62.0	31.0	19.0	12.8	8.0	6.0
1" Series 40 and 45	Brass	321 (150)	129 (83.5)	46.8	23.6	14.5	9.6	6.9	5.1
	Carbon Steel	410 (270)	249 (150)	90.3	45.6	27.8	18.5	13.2	9.8
	A.I.S.I. 304 & 316	483 (350)	272 (208)	97.3	49.7	30.4	20.3	14.5	10.7
	Monel	396 (306)	214 (167)	77.5	39.2	23.8	16.0	10.3	7.7



Note: Where single values appear in table, thermowell may be considered safe for water, steam, air or gas. The values in parentheses in the shorter insertion lengths represent safe values for water flow, taking into consideration the velocity pressure effect of water flowing at higher velocities.

Temperature Sensing



Thermowells

Series 50 (.260" Bore) & Series 55 (.385" Bore) for 1/4" and 3/8" Diameter Elements

Flanged

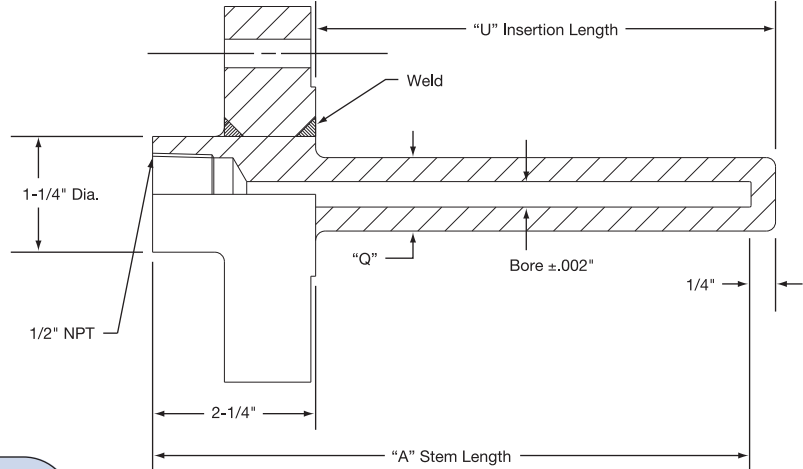
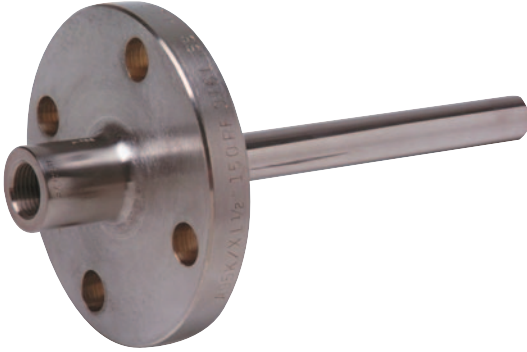

Standard Sizes

"U" (in)	"A" (in)	Part Number			
		1" Flange		1 1/2" Flange	
		.260 Bore Q = 3/4"	.385 Bore Q = 7/8"	.260 Bore Q = 3/4"	.385 Bore Q = 7/8"
2	4	TWL5021	TWL5521	TWL5028	TWL5528
4	6	TWL5022	TWL5522	TWL5029	TWL5529
7	9	TWL5023	TWL5523	TWL5030	TWL5530
10	12	TWL5024	TWL5524	TWL5031	TWL5531
13	15	TWL5025	TWL5525	TWL5032	TWL5532
16	18	TWL5026	TWL5526	TWL5033	TWL5533
22	24	TWL5027	TWL5527	TWL5034	TWL5534

• Flanges are 150-lb. Raised Face. Other Facings and Pressure Ranges are available.

Ordering Information

Complete the Part Number by filling in the box with the number designating the material.

- 1 = Steel**
- 2 = Brass**
- 3 = 316 Stainless Steel**
- 4 = 304 Stainless Steel**
- 5 = Monel**

Maximum Fluid Velocity Feet Per Second

(See Velocity Ratings on page 14-76)

Well Type	Material	Insertion Length — "U" (in)						
		2	4	7	10	13	16	22
Series 50 and 60	Carbon Steel	404 (129)	184 (71.2)	67.0 (42.7)	34.0	20.6	13.7	7.4
	A.I.S.I. 304 & 316	430 (179)	192 (99.3)	69.7 (59.6)	35.4	21.5	14.3	7.7
	Monel	350 (143)	168 (79.8)	61 (47.7)	31.0	18.8	12.5	6.7
Series 55 and 65	Carbon Steel	410 (152)	248 (84.3)	91.3 (50.6)	45.7	27.6	18.5	10.0
	A.I.S.I. 304 & 316	444 (211)	258 (117)	95.2 (70.3)	47.6	28.8	19.3	10.4
	Monel	338 (168)	226 (93.3)	83.3 (56.0)	41.6	25.2	16.9	9.1



Note: Where single values appear in table, thermowell may be considered safe for water, steam, air or gas. The values in parentheses in the shorter insertion lengths represent safe values for water flow, taking into consideration the velocity pressure effect of water flowing at higher velocities.

Maximum Flange Pressure — Temperature Rating

(lbs. per square inch)

Material	Temperature °F			
	0°	800°	1000°	1125°
Carbon Steel	2500	2500	—	—
A.I.S.I. 304	2500	2500	2500	—
A.I.S.I. 316	2500	2500	2500	2500
Monel	2500	2500	—	—

WARNING: Cancer and Reproductive Harm - www.P65Warnings.ca.gov.

Series 60 (.260" Bore) & Series 65 (.385" Bore) for 1/4" and 3/8" Elements

Van Stone

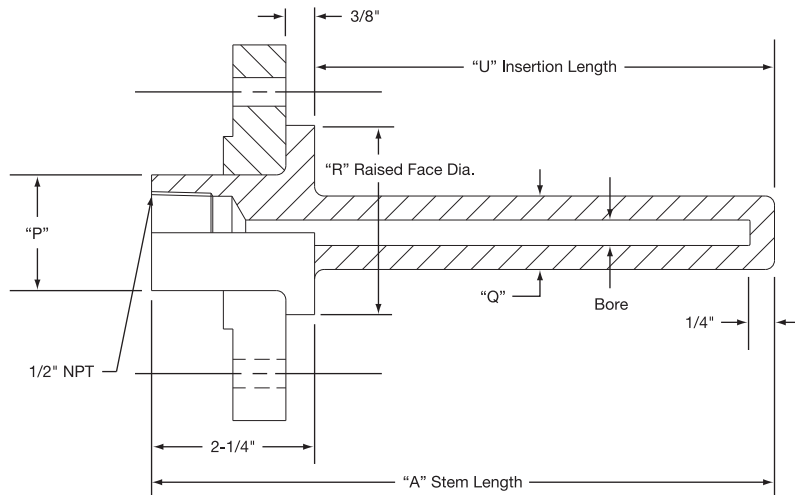

Standard Sizes

"U" (in)	"A" (in)	Part Number			
		1" Flange R = 2", P = 1.315"		1 1/2" Flange R = 2 7/8", P = 1.900"	
		.260 Bore Q = 3/4"	.385 Bore Q = 7/8"	.260 Bore Q = 3/4"	.385 Bore Q = 7/8"
2	4	TWL6021	TWL6521	TWL6028	TWL6528
4	6	TWL6022	TWL6522	TWL6029	TWL6529
7	9	TWL6023	TWL6523	TWL6030	TWL6530
10	12	TWL6024	TWL6524	TWL6031	TWL6531
13	15	TWL6025	TWL6525	TWL6032	TWL6532
16	18	TWL6026	TWL6526	TWL6033	TWL6533
22	24	TWL6027	TWL6527	TWL6034	TWL6534

• Catalog Part Numbers fit 1" and 1-1/2" Lap Joint Flanges

Ordering Information

Complete the Part Number by filling in the box with the number designating the material.

- 1 = Steel**
- 2 = Brass**
- 3 = 316 Stainless Steel**
- 4 = 304 Stainless Steel**
- 5 = Monel**

⚠ WARNING: Cancer and Reproductive Harm - www.P65Warnings.ca.gov.

Thermowell Corrosive Service Guide

Corrodent	Temp. °F	Conc. %	Recommended Material
Acetic Acid	212	All	Monel
Acetic Anhydride	300		Nickel
Acetone	212	All	304 SS
Acetylene	400		304 SS
Alcohols	212	All	304 SS
Alum (Potassium or Sodium)	300	All	Hast. C
Aluminum Chloride	212	All	Hast. B
Aluminum Sulfate	212	All	316 SS
Ammonia, Dry	212	All	304 SS, 316 SS
Ammonium Chloride	300	50%	Monel
Ammonium Hydroxide (Ammonia, Aqua)	212	All	304 SS, 316 SS
Ammonium Nitrate	300	All	304 SS
Ammonium Sulfate	212	All	316 SS
Amyl Acetate	300	All	304 SS
Aniline	75		Monel
Asphalt	250		304 SS
Atmosphere, (Industrial and Marine)			304 SS
Barium Compounds	See Calcium		
Beer	70		304 SS
Benzene (Benzol)	212		Steel
Benzoic Acid	212	All	316 SS
Bleaching Powder	70	15%	Monel
Borax	212	All	Brass
Bordeaux Mixture	200		304 SS
Boric Acid	400	All	316 SS
Bromine	125	Dry	Monel
Butane	400	All	Steel
Butyl Alcohol	See Alcohols		
Butyric Acid	212		Hast. C
Calcium Bisulphite	75	All	Hast. C
Calcium Chloride	212	All	Hast. C
Calcium Hydroxide	300	20%	Hast. C
Calcium Hypochlorite	See Bleaching Powder		
Carbolic Acid	See Phenol		
Carbon Dioxide, Dry	800	All	Brass
Carbon Disulfide	200		304 SS
Carbon Tetrachloride	125	All	Monel
Carbonated Beverages	212		304 SS
Carbonated Water	212	All	304 SS
Chloracetic Acid	212	All	Monel
Chlorine, Dry	100		Monel
Chlorine, Moist	100	All	Monel
Chloroform, Dry	212		Monel
Chromic Acid	300	All	Hast. C
Cider	300	All	304 SS
Citric Acid	212	All	Hast. C
Copper (10) Chloride	212	All	Hast. C
Copper (10) Nitrate	300	All	316 SS
Copper (10) Sulfate	300	All	316 SS
Copper Plating Solution (Acid)	75		304 SS
Copper Plating Solution (Cyanide)	180		304 SS
Corn Oil	200		304 SS
Creosote	200	All	304 SS
Crude Oil	300		Monel
Ethanol	See Alcohols		
Ethyl Acetate	See Lacquer Thinner		
Ethyl Chloride, Dry	500		Steel
Ethylene Glycol (Uninhibited)	212	All	304 SS
Ethylene Oxide	75		Steel
Fatty Acids	500	All	316 SS
Ferric Chloride	75	All	Hast. C
Ferric Sulfate	300	All	304 SS
Formaldehyde	212	40%	316 SS
Formic Acid	300	All	316 SS
Fluorine, Anhydrous	100		304 SS
Freon	300		Steel
Furfural	450		316 SS
Gasoline	300		Steel
Glucose	300		304 SS
Glue ph 6-8	300	All	304 SS
Glycerine	212	All	Brass
Hydrobromic Acid	212	All	Hast. C

Corrodent	Temp. °F	Conc. %	Recommended Material
Hydrochloric Acid (37-38%)	225	All	Hast. B
Hydrocyanic Acid	212	All	304 SS
Hydrofluogilicic Acid	212	40%	Monel
Hydrofluoric Acid	212	60%	Monel
Hydrogen Chloride, Dry	500		304 SS
Hydrogen Fluoride, Dry	175		Steel
Hydrogen Peroxide	125	10-100%	304 SS
Kerosene	300	All	Steel
Lacquers & Thinners	300	All	304 SS
Lactic Acid	300	All	316 SS
Lime	212	All	316 SS
Linseed Oil	75		Steel
Magnesium Chloride	212	50%	Nickel
Magnesium Hydroxide (or Oxide)	75	All	304 SS
Magnesium Sulfate	212	40%	304 SS
Mercuric Chloride	75	10%	Hast. C
Mercury	700	100%	Steel
Methyl Chloride, Dry	75		Steel
Methylene Chloride	212	All	304 SS
Milk, fresh or sour	180		304 SS
Molasses	See Glucose		
Natural Gas	70		304 SS
Nitric Acid	75	All	304 SS
Nitric Acid	110	All	316 SS
Oleic Acid	See Fatty Acids		
Oxalic Acid	212	All	Monel
Oxygen	75	All	Steel
Palmitic Acid	See Fatty Acids		
Phenol	212	All	316 SS
Phosphoric Acid	212	All	316 SS
Photographic Bleaching	100	All	304 SS
Potassium Compounds	See Sodium Compounds		
Propane	300		Steel
Rosin	700	100%	316 SS
Salt or Brine	See Sodium Chloride		
Sea Water	75		Monel
Soap & Detergents	212	All	304 SS
Sodium Bicarbonate	212	20%	316 SS
Sodium Bisulfate	212	20%	304 SS
Sodium Bisulfite	212	20%	304 SS
Sodium Carbonate	212	40%	316 SS
Sodium Chloride	300	30%	Monel
Sodium Chromate	212	All	316 SS
Sodium Cyanide	212	All	304 SS
Sodium Hydroxide	212	30%	316 SS
Sodium Hypochlorite	75	10%	Hast. C
Sodium Nitrate	212	40%	304 SS
Sodium Nitrite	75	20%	316 SS
Sodium Phosphate	212	10%	Steel
Sodium Silicate	212	10%	Steel
Sodium Sulfate	212	30%	316 SS
Sodium Sulfide	212	10%	316 SS
Sodium Sulfite	212	30%	304 SS
Sodium Thiosulfate	212	All	304 SS
Steam			304 SS
Stearic Acid	See Fatty Acids		
Sugar Solutions	See Glucose		
Sulfur	500		304 SS
Sulfur Chloride	75	Dry	316 SS
Sulfur Dioxide	500	Dry	316 SS
Sulfur Trioxide	500	Dry	316 SS
Sulfuric Acid	212	10%	316 SS
Sulfuric Acid	212	10-90%	Hast. B
Sulfuric Acid	212	90-100%	Hast. B
Sulfuric Acid, Fuming	175		Carp. 20
Sulfurous Acid	75	20%	316 SS
Tannic Acid	75	40%	Hast. B
Titanium Tetrachloride	75	All	316 SS
Toluene	75		Steel
Trichloroacetic Acid	75	All	Hast. B
Trichlorethylene	300	Dry	Monel
Turpentine	75		316 SS
Varnish	150		Steel
Zinc Chloride	212	All	Hast. B
Zinc Sulfate	212	All	316 SS

This information is given as a guide only. Final material selection should be made by the user based on their knowledge of the application.

Ceramic Protection Tubes Application Data

Ceramic Protection Tubes are used in applications where contamination from hostile environments or the cutting action of concentrated and direct flame impingement are factors. Such conditions usually require a noble metal thermocouple such as platinum and platinum alloys.

When selecting assemblies using ceramic components, the expected maximum temperatures must be considered. At elevated temperatures, some ceramic materials go through a glass phase. As silica is a prime contaminant of platinum, alumina protecting tubes and insulators are recommended for temperatures exceeding 2000°F (1093°C).

Material	Maximum Operating Temperature	Thermal Shock Characteristics	Maximum Available Length (in)	Typical Applications	Remarks
Alumina (99.7%)	3100°F (1700°C)	Fair (preheating to 900°F [482°C] recommended)	84	Iron, Barium, crown glass; non-ferrous metals; gas-tight protection for noble metal thermocouples in excess of 2400°F (1316°C)	Sags at 2900°F (1593°C) Prevents dry hydrogen penetration
Porcelain (Mullite)	2550°F (1400°C)	Poor (preheating to 900°F [482°C] recommended)	84	Non-ferrous metals; gas-tight protection for noble metal thermocouples to 2400°F (1316°C)	Sags at 2550°F (1400°C) Prone to attack by halogen gases; some penetration of dry hydrogen. Contains silica.

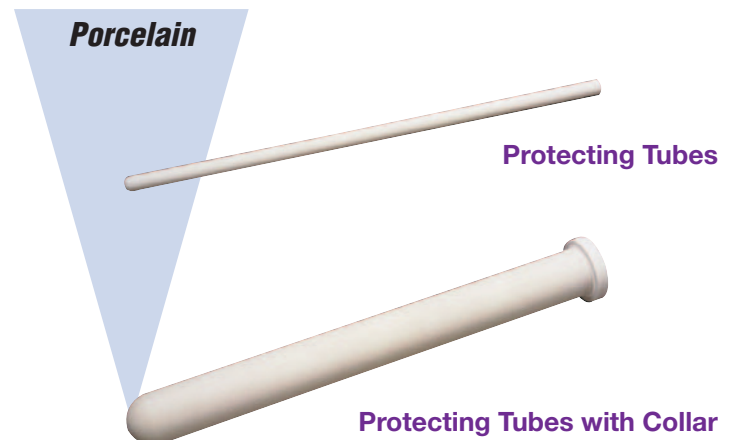

Part Number	I.D. x O.D. †	Construction	Length
APT-101- <input type="text"/>	1/4" x 3/8"	Plain End	12" thru 48" in 6" increments
APT-102- <input type="text"/>	7/16" x 1/16"	Plain End	12" thru 60" in 6" increments
APT-103- <input type="text"/>	3/4" x 1"	Plain End	12" thru 72" in 6" increments
APT-104- <input type="text"/>	1" x 1 1/4"	Plain End	12" thru 72" in 6" increments
APT-105- <input type="text"/>	1/4" x 3/8"	With Hex Fitting	12" thru 48" in 6" increments
APT-106- <input type="text"/>	7/16" x 1/16"	With Hex Fitting	12" thru 60" in 6" increments

Part Number	I.D. x O.D. †	Construction	Length
PPT-101- <input type="text"/>	1/4" x 3/8"	Plain End	12" through 84" inch 6" increments
PPT-102- <input type="text"/>	7/16" x 1/16"	Plain End	
PPT-103- <input type="text"/>	3/4" x 1"	Plain End	
PPT-104- <input type="text"/>	1" x 1 1/4"	Plain End	
PPT-105- <input type="text"/>	1/4" x 3/8"	w/ Collar Approx. 5/16" x 3/4"	
PPT-106- <input type="text"/>	7/16" x 1/16"	w/ Collar Approx. 5/16" x 1 1/16"	
PPT-107- <input type="text"/>	3/4" x 1"	w/ Collar Approx. 5/16" x 1 3/8"	
PPT-108- <input type="text"/>	1" x 1 1/4"	w/ Collar Approx. 5/16" x 1 3/8"	
PPT-109- <input type="text"/>	1/4" x 3/8"	w/Hex Fitting	
PPT-110- <input type="text"/>	7/16" x 1/16"	w/Hex Fitting	

Ordering Information

Complete the Part Number with 3 digits indicating length in whole inches.

Example: = APT-105- is 12" long and PPT-107- is 48" long.

† Dimensional tolerance:
Up to 1" Dia. ±5% or .025", whichever is greater
Over 1" Dia. ±4% or .050", whichever is greater

⚠ WARNING: Cancer and Reproductive Harm - www.P65Warnings.ca.gov.

Metal Protection Tubes

Metal Protection Tubes

For longer life and continued accuracy, most thermocouples in industrial applications should be protected from physical damage, corrosion, and contamination by some type of

protecting tube or well. Metal tubes selected to suit the temperature, pressure and atmosphere are generally used with base metal thermocouples.



Typical Metal Protection Tube



Typical Cast Iron Protection Tube

Material	Maximum Operating Temperature	Typical Applications	Remarks
304 Stainless	1800°F (982°C)	Food and Dairy Products, Petroleum Products, Mild Acids, Alkalies	Embrittles in 800°F (427°C) to 1400°F (760°C) range.
Cast Iron	1300°F (704°C)	Molten Aluminum, Gas Ducts	Withstands sulphur and caustic solutions.
316 Stainless	1800°F (982°C)	Food and Dairy Products, Petroleum Products, Mild Acids, Alkalies	Greater corrosion resistance than 304 Stainless.
446 Stainless	2000°F (1093°C)	Sulphurous Atmospheres such as Hydrogen Sulphide, Neutral Salt Baths	Excellent resistance to corrosion and oxidation at high temperatures. Do not use in carburizing atmospheres.
Inconel 601®	2200°F (1204°C)	Neutral Salt Baths, Carburizing and Nitriding Atmospheres	Good resistance to corrosion at high temperatures; excellent resistance to oxidation at high temperatures. Do not use in carburizing atmospheres above 1000°F (538°C).
Black Steel Pipe per ASTM A120	1200°F (649°C)	Molten Babbitt, Tin, Lead, and Magnesium	Low Cost

304 Stainless Steel (8% Nickel-18% Chrome)

Part Number	I.D. x O.D.	NPT Thread	Const.	Length
*MPT-101-___	.622" x .840"	½"	Welded	12" and over in 6" increments
*MPT-102-___	.824" x 1.050"	¾"	Welded	
*MPT-103-___	1.049" x 1.315"	1"	Welded	

*If extra heavy wall is desired, specify.

Cast Iron

Part Number	I.D. x O.D.	NPT Thread	Const.	Length
MPT-104-___	⅞" x 1⅜"	¾" Int.*	Cast	12" thru 72" in 6" increments
MPT-105-___	⅞" x 1⅜"	1" Ext.	Cast	12" thru 48" in 6" increments

*1" NPT external thread available on special request.

316 Stainless Steel

Part Number	I.D. x O.D.	NPT Thread	Const.	Length
MPT-106-___	.622" x .840"	½"	Welded	12" and over in 6" increments
MPT-107-___	.824" x 1.050"	¾"	Welded	
MPT-108-___	1.049" x 1.315"	1"	Welded	

446 Stainless Steel (28% Chrome Iron)

Part Number	I.D. x O.D.	NPT Thread	Const.	Length
MPT-109-___	.622" x .840"	½"	Seamless	12" and over in 6" increments
MPT-110-___	.824" x 1.050"	¾"	Seamless	
MPT-111-___	1.049" x 1.315"	1"	Seamless	

Inconel Alloy 601® (60% Nickel-23% Chrome-14% Iron)

Part Number	I.D. x O.D.	NPT Thread	Const.	Length
MPT-112-___	.622" x .840"	½"	Seamless	12" and over in 6" increments
MPT-113-___	.824" x 1.050"	¾"	Seamless	
MPT-114-___	1.049" x 1.315"	1"	Seamless	

Black Steel Pipe (Per ASTM A120)

Part Number	I.D. x O.D.	NPT Thread	Const.	Length
MPT-115-___	.364" x .540"	¼"	Welded	12" and over in 6" increments
MPT-116-___	.302" x .540"	¼"	Welded	
MPT-117-___	.546" x .840"	½"	Welded	
MPT-118-___	.742" x 1.050"	¾"	Welded	
MPT-119-___	.957" x 1.315"	1"	Welded	

Ordering Information

Complete the Part Number with 3 digits indicating length in whole inches.

Example: = MPT-105-**012** is 12" long and
MPT-107-**048** is 48" long.

⚠ WARNING: Cancer and Reproductive Harm - www.P65Warnings.ca.gov.

Bayonet Type Adapters



Spring-Loaded Bayonet Cap Type Thermocouples are used in conjunction with bayonet adapters. After inserting the thermocouple sheath through the adapter the spring is compressed and locked by the cap, pushing the sensing junction tight against the surface being measured for increased accuracy and faster response time.

Adapter Selection and Installation

1. Select an adapter length by comparing the hole depth and thermocouple probe length in Table 1A.
2. Select from Table 1B a thread type for the adapter length determined in Table 1A.

Table 1A—Adapter Length for Bayonet Type Thermocouples (page 14-4) and RTDs (page 14-62)

Hole "C" (in)	Probe Length A (in)		
	7/8" Long Adapter	1-3/8" Long Adapter	2-1/2" Long Adapter
1/4 to 1/2	1 5/8	2	3 3/8
1/2 to 1	2	2 1/2	3 3/8
1 to 1 1/2	2 1/2	3	4 1/8
2 to 2 1/2	3 1/2	4	5 1/8
2 1/2 to 3	4	4 1/2	5 5/8
3 to 3 1/2	4 1/2	5	6 1/8
3 1/2 to 4	5	5 1/2	6 5/8
4 to 4 1/2	5 1/2	6	7 1/8
4 1/2 to 5	6	6 1/2	7 5/8
5 to 5 1/2	6 1/2	7	8 1/8
5 1/2 to 6	7	7 1/2	8 5/8
6 to 6 1/2	7 1/2	8	9 1/8

Table 1B—Bayonet Adapter for Threaded Type Thermocouples and RTDs

Part Number	Length (in)	Thread	Material
TCA-104-101	3/8	1/8"-27 NPT	Plated Steel
TCA-104-103	1 1/8	1/8"-27 NPT	Plated Steel
TCA-104-121	1 1/2	1/8"-27 NPT	Plated Steel
TCA-104-118	2	1/8"-27 NPT	Plated Steel
TCA-104-105	2 1/2	1/8"-27 NPT	Plated Steel
TCA-104-115	3 1/2	1/8"-27 NPT	Plated Steel
TCA-104-110	4	1/8"-27 NPT	Plated Steel
TCA-104-102	7/8	3/8"-24 UNF	Plated Steel
TCA-104-104	1 1/8	3/8"-24 UNF	Plated Steel
TCA-104-106	2 1/2	3/8"-24 UNF	Plated Steel
TCA-104-107	2 3/8	14 × 1.5mm	Stainless Steel
TCA-104-108	2 1/2	10 × 1.5mm	Plated Steel
TCA-104-111	2 1/2	12 × 1mm	Plated Steel
†TCA-104-116	2 1/2	12 × 1.5mm	Plated Steel
TCA-104-126	2	12 × 1mm	Plated Steel
†TCA-104-127	1	12 × 1mm	Plated Steel
TCA-104-128	1	12 × 1.75mm	Plated Steel
TCA-104-131	3	12 × 1mm	Plated Steel
TCA-104-132	5	12 × 1mm	Plated Steel

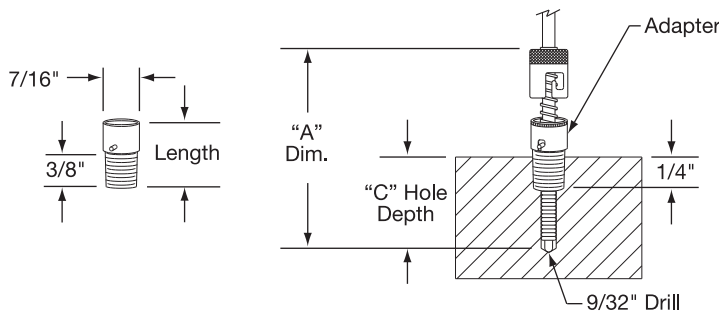

†Must be used with 12 mm ID bayonet caps

Pipe Clamp Adapters for Bayonet Type Thermocouples

Spring-loaded bayonet cap type thermocouples are used in conjunction with bayonet adapters. After inserting the thermocouple sheath through the adapter the spring is compressed and locked by the cap, pushing the sensing junction tight against the surface being measured for increased accuracy and faster response time.

Pipe Clamp adapters permit thermocouple placement without the drilling and tapping of holes to attach the adapter.

Part Number	Pipe Diameter (in)	
	Min.	Max.
TCH00001	1/2	7/8
TCH00002	7/8	1 1/2
TCH00003	1 1/16	2 1/4
TCH00004	2 1/4	3 3/16
TCH00005	3 5/16	4 1/4
TCH00006	4 7/16	5 1/4

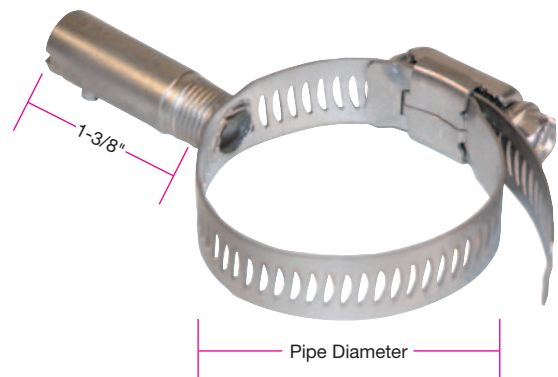

Protection Tube Mounting Parts

For Ceramic Tubes



FTG-148-101
FTG-148-102

Part Number	Description
FTG-148-101	3/4" NPT x 1/2" NPT Brass reducing hex nipple for PPT-102-□ or APT-102-□ tube
FTG-148-102	3/4" NPT x 1/2" NPT Steel reducing hex nipple for PPT-102-□ or APT-102-□ tube



FLG-122-101
FLG-122-102
FLG-122-103



FTG-149-101
FTG-149-102
FTG-149-103



FTG-150-101
FTG-150-102
FTG-150-103

For Metal Tubes

Part Number	Description
FLG-122-101	15/16" I.D. x 3 1/2" Cast Iron Flange for 1/2" IPS
FLG-122-102	1 1/4" I.D. x 3 9/16" Cast Iron Flange for 3/4" IPS
FLG-122-103	1 7/16" I.D. x 3 11/16" Cast Iron Flange for 1" IPS
FTG-149-101	1/2" NPT x 1/2" NPT Malleable 90° Elbow
FTG-149-102	3/4" NPT x 3/4" NPT Malleable 90° Elbow
FTG-149-103	1" NPT x 1" NPT Malleable 90° Elbow
FTG-150-101	1/2" NPT x 1/2" NPT Universal Elbow
FTG-150-102	3/4" NPT x 3/4" NPT Universal Elbow
FTG-150-103	1" NPT x 1" NPT Universal Elbow

Sensor Mounting Fixed Fittings

Mounting fittings are sometimes necessary for the installation of thermocouple and RTD probes. The two basic types of fixed fittings are the Hex Bushing and the Hex Nipple, most commonly made of either Brass or Stainless Steel.

Fixed fittings are brazed to the sheath of the probe; therefore the immersion length "U" must be specified in inches or millimeters. The immersion length is from the probe tip to the beginning of the thread on the fitting.

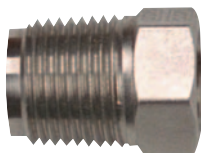

Hex Bushing

Sheath Diameter (in)	Male NPT (in)	Overall Length (in)	Hex Across Flats (in)	Part Number	
				Brass	Stainless Steel
1/16	1/8	3/4	7/16	FTG-159-101	FTG-162-101
	1/4	1	9/16	FTG-159-102	FTG-162-102
	1/2	1 1/4	7/8	FTG-159-103	FTG-162-103
1/8	1/8	3/4	7/16	FTG-159-104	FTG-162-104
	1/4	1	9/16	FTG-159-105	FTG-162-105
	1/2	1 1/4	7/8	FTG-159-106	FTG-162-106
3/16	1/8	3/4	7/16	FTG-159-107	FTG-162-107
	1/4	1	9/16	FTG-159-108	FTG-162-108
	1/2	1 1/4	7/8	FTG-159-109	FTG-162-109
1/4	1/8	3/4	7/16	FTG-159-110	FTG-162-110
	1/4	1	9/16	FTG-159-111	FTG-162-111
	1/2	1 1/4	7/8	FTG-159-112	FTG-162-112
5/16	1/4	1	9/16	FTG-159-113	FTG-162-113
	1/2	1 1/4	7/8	FTG-159-114	FTG-162-114
3/8	1/4	1	9/16	FTG-159-115	FTG-162-115
	1/2	1 1/4	7/8	FTG-159-116	FTG-162-116

Sensor Mounting Fixed Fittings

Sheath Diameter (in)	Male NPT (in)	Overall Length (in)	Hex Across Flats (in)	Part Number	
				Brass	Stainless Steel
1/16	1/4	1 ¹³ / ₃₂	9/16	FTG-152-101	FTG-153-101
	1/2	1 ²⁷ / ₃₂	7/8	FTG-152-102	FTG-153-102
1/8	1/4	1 ¹³ / ₃₂	9/16	FTG-152-103	FTG-153-103
	1/2	1 ²⁷ / ₃₂	7/8	FTG-152-104	FTG-153-104
3/16	1/4	1 ¹³ / ₃₂	9/16	FTG-152-105	FTG-153-105
	1/2	1 ²⁷ / ₃₂	7/8	FTG-152-106	FTG-153-106
1/4	1/4	1 ¹³ / ₃₂	9/16	FTG-152-107	FTG-153-107
	1/2	1 ²⁷ / ₃₂	7/8	FTG-152-108	FTG-153-108
5/16	1/4	1 ¹³ / ₃₂	9/16	FTG-152-109	FTG-153-109
	1/2	1 ²⁷ / ₃₂	7/8	FTG-152-110	FTG-153-110
3/8	1/4	1 ¹³ / ₃₂	9/16	FTG-152-111	FTG-153-111
	1/2	1 ²⁷ / ₃₂	7/8	FTG-152-112	FTG-153-112

Hex Nipple



MNPT (in)	Sheath O.D. (in)	Part Number			
		Non-Adjustable Brass	Non-Adjustable Stainless Steel	Adjustable Brass	Adjustable Stainless Steel
1/16	1/16	FTG-154-101	FTG-155-101	FTG-156-101	FTG-157-101
	1/8	FTG-154-102	FTG-155-102	FTG-156-102	FTG-157-102
1/8	1/16	FTG-154-104	FTG-155-104	FTG-156-104	FTG-157-104
	1/8	FTG-154-105	FTG-155-105	FTG-156-105	FTG-157-105
	3/16	FTG-154-106	FTG-155-106	FTG-156-106	FTG-157-106
	1/4	FTG-154-107	FTG-155-107	FTG-156-107	FTG-157-107
1/4	1/16	FTG-154-110	FTG-155-110	FTG-156-110	FTG-157-110
	1/8	FTG-154-111	FTG-155-111	FTG-156-111	FTG-157-111
	3/16	FTG-154-112	FTG-155-112	FTG-156-112	FTG-157-112
	1/4	FTG-154-113	FTG-155-113	FTG-156-113	FTG-157-113
	3/16	FTG-154-114	FTG-155-114	FTG-156-114	FTG-157-114
	3/8	FTG-154-115	FTG-155-115	FTG-156-115	FTG-157-115
1/2	1/8	FTG-154-116	FTG-155-116	FTG-156-116	FTG-157-116
	1/4	FTG-154-117	FTG-155-117	FTG-156-117	FTG-157-117
	3/8	FTG-154-118	FTG-155-118	FTG-156-118	FTG-157-118

Compression Fittings

There are non-adjustable and adjustable compression fittings. Non-adjustable compression fittings have a metal ferrule which is compressed onto the sheath and deformed permanently in the application; the fitting cannot be relocated along the sheath after tightening. Adjustable compression fittings have a Teflon® ferrule and the fitting can be relocated several times if immersion length is changed.



Sheath Diameter (in)	Part Number
1/8	FTG-158-101
3/16	FTG-158-102
1/4	FTG-158-103

Stainless steel 1/2" NPT × 1/2" NPT

Spring-Loaded Hex Nipple



Standard Quick Disconnect Plugs and Jacks

Design Features:

- * Quick, positive connections.
- * Bodies are ANSI color coded, glass filled nylon with a temperature rating of 350°F (177°C) continuous and 400°F (204°C) intermittent.
- * Pins are made from matching thermocouple material except R and S, which are compensated.
- * Plugs available in hollow or solid pins.
- * Plugs and Jacks are interchangeable with other thermocouple connectors with standard 7/16-inch spacing.
- * Can be imprinted with customer's own name (minimum order and tooling charge applies).

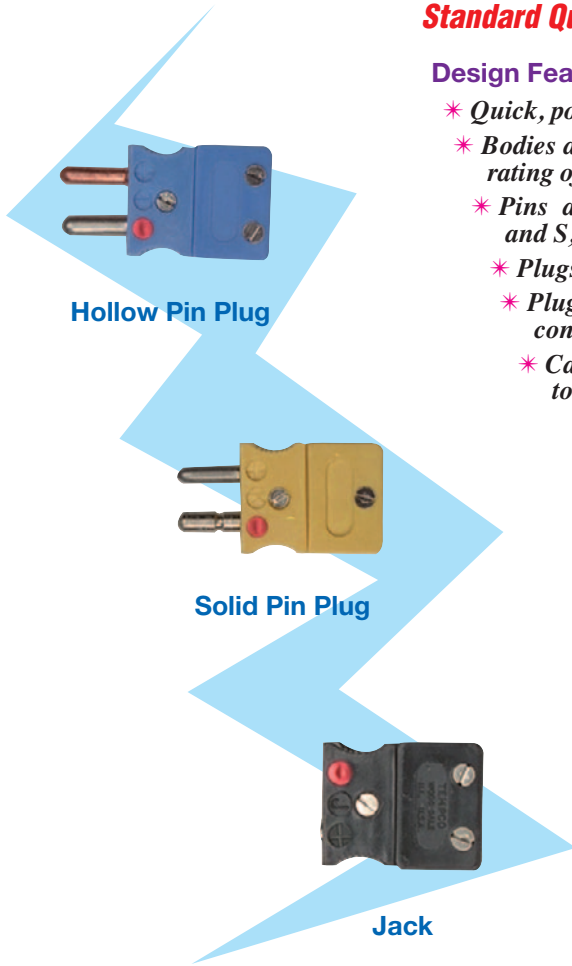

ANSI Calibration	Body Color	Part Number		
		Hollow Pin Plug	Solid Pin Plug	Jack
J	Black	TCA-101-101	TCA-101-111	TCA-102-101
K	Yellow	TCA-101-102	TCA-101-112	TCA-102-102
T	Blue	TCA-101-103	TCA-101-113	TCA-102-103
E	Purple	TCA-101-107	TCA-101-114	TCA-102-107
N	Orange	TCA-101-108	TCA-101-115	TCA-102-108
R/S	Green	TCA-101-109	TCA-101-116	TCA-102-109
U*	White	TCA-101-110	TCA-101-117	TCA-102-110

* "U" is designated for RTDs and type B thermocouples

High Temperature Standard Quick Disconnect Plugs and Jacks

- * All of the same features as the standard Plugs and Jacks except body color comes in "Brown" only
- * Temperature rating of 500°F (260°C) continuous and 550°F (288°C) intermittent

ANSI Calibration	Body Color	Part Number		
		Hollow Pin Plug	Solid Pin Plug	Jack
J	Brown	TCA-101-118	TCA-101-125	TCA-102-111
K	Brown	TCA-101-119	TCA-101-126	TCA-102-112
T	Brown	TCA-101-120	TCA-101-127	TCA-102-113
E	Brown	TCA-101-121	TCA-101-128	TCA-102-114
N	Brown	TCA-101-122	TCA-101-129	TCA-102-115
R/S	Brown	TCA-101-123	TCA-101-130	TCA-102-116
U*	Brown	TCA-101-124	TCA-101-131	TCA-102-117

* "U" is designated for RTDs and type B thermocouples

Ultra-High Temperature Quick Disconnect Plugs and Jacks

- * Temperature rating of 800°F (427°C) continuous and 1000°F (538°C) intermittent

ANSI Calibration	Body Color	Part Number		
		Hollow Pin Plug	Solid Pin Plug	Jack
J	Reddish-Brown	TCA-101-161	TCA-101-160	TCA-102-187
K	Reddish-Brown	TCA-101-163	TCA-101-159	TCA-102-189

Other calibrations available upon request.

Miniature Quick Disconnect Plugs and Jacks

Design Features:

- * Designed to be lightweight and to be space-saving.
- * Bodies are ANSI color coded, glass filled nylon with a temperature rating of 350°F (177°C) continuous and 400°F (204°C) intermittent.
- * Pins are solid flat with 5/16" spacing, made from matching thermocouple material except R and S, which are compensated.
- * Plugs and jacks are interchangeable with other miniature connectors.
- * Will accept wire from .001" to .032" and sheath diameters from .010" to .188".
- * Negative pin marked with red disc.
- * Complements modern miniature instrumentation.

ANSI Calibration	Body Color	Part Number	
		Plug	Jack
J	Black	TCA-101-105	TCA-102-118
K	Yellow	TCA-101-104	TCA-102-119
T	Blue	TCA-101-132	TCA-102-120
E	Purple	TCA-101-133	TCA-102-121
N	Orange	TCA-101-134	TCA-102-122
R/S	Green	TCA-101-135	TCA-102-123
U*	White	TCA-101-136	TCA-102-124

* "U" is designated for RTDs and type B thermocouples



Plug – Male



Jack – Female

Standard 3-Pin Quick Disconnect Plugs and Jacks

Design Features:

- * Standard 3-Pin Plugs and Jacks accept all accessories of the standard 2-pin plug and jack except the spool type brazing adapter and neoprene boot.
- * 3-Pin Plug is available with all three pins being solid or with the two thermocouple pins being hollow.
- * Has all the same features as the standard 2-Pin Plug and Jack

ANSI Calibration	Body Color	Part Number		
		Hollow Pin Plug	Solid Pin Plug	Jack
J	Black	TCA-101-137	TCA-101-143	TCA-102-125
K	Yellow	TCA-101-138	TCA-101-144	TCA-102-126
T	Blue	TCA-101-139	TCA-101-145	TCA-102-127
E	Purple	TCA-101-140	TCA-101-146	TCA-102-128
R/S	Green	TCA-101-141	TCA-101-147	TCA-102-129
U*	White	TCA-101-142	TCA-101-148	TCA-102-130

* "U" is designated for RTDs and type B thermocouples

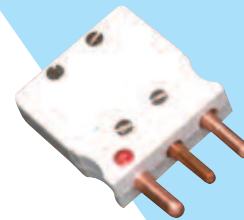

Plug – Male



Jack – Female

Miniature 3-Pin Quick Disconnect Plugs and Jacks

Design Features:

- * Has all the same standard features as the 2-Pin miniature Plug and Jack.
- * The miniature 3-pin plugs and jacks will accept all accessories of the 2-Pin Plugs and Jacks except the cable clamp and neoprene boot.

ANSI Calibration	Body Color	Part Number	
		Plug	Jack
J	Black	TCA-101-149	TCA-102-131
K	Yellow	TCA-101-150	TCA-102-132
T	Blue	TCA-101-151	TCA-102-133
E	Purple	TCA-101-152	TCA-102-134
R/S	Green	TCA-101-153	TCA-102-135
U*	White	TCA-101-154	TCA-102-136

* "U" is designated for RTDs and type B thermocouples



Plug – Male



Jack – Female

Accessories for Standard Plugs and Jacks



For 3/8" Diameter sheath or 1/4" armor cable
Cable Clamp
 Part Number: TCA-107-102

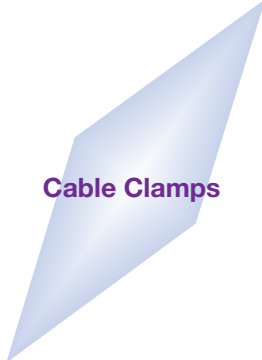

Cable Clamps

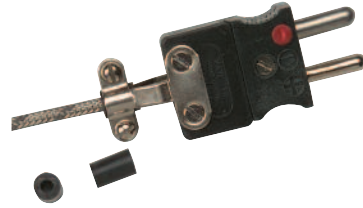

For Lead Wire with or without Braid
Cable Clamp
 Part Number TCA-107-106
Neoprene Grommet
 Part Number TCA-109-102



Grommets used in place of Cable Clamp
 Part Number TCA-109-105
Washer protects fine wire from breakage
 Part Number TCA-120-101



Neoprene Wire Entrance Grommets Nylon Wire Protection Washers

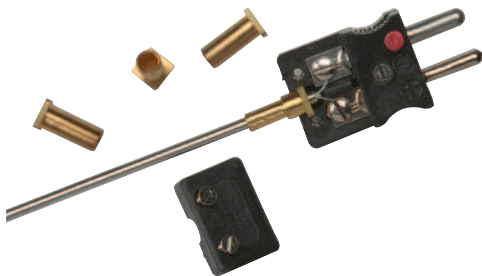

Brass Crimping Inserts

Used Primarily with TEMPCO-PAK

Sheath Diameter	Part Number
Undrilled	TCA-112-101
.020" (0.5 mm)	TCA-112-102
.040" (1.0 mm)	TCA-112-103
.063" (1.6 mm)	TCA-112-104
.125" (3.17 mm)	TCA-112-105
.188" (4.77 mm)	TCA-112-106
.250" (6.35 mm)	TCA-112-107
.118" (3.0 mm)	TCA-112-108
.177" (4.5 mm)	TCA-112-109
.236" (6.0 mm)	TCA-112-110

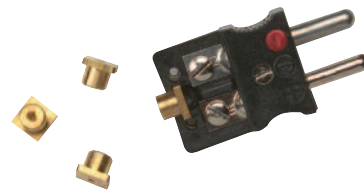

Brass Brazing Inserts

Can be used with Tubing or TEMPCO-PAK

Sheath Diameter	Part Number
Undrilled	TCA-113-101
.020" (0.5 mm)	TCA-113-102
.040" (1.0 mm)	TCA-113-103
.063" (1.6 mm)	TCA-113-104
.125" (3.17 mm)	TCA-113-105
.188" (4.77 mm)	TCA-113-106
.250" (6.35 mm)	TCA-113-107
.236" (6.0 mm)	TCA-113-108

Accessories for Standard Plugs and Jacks

Compression Type Tube Adapters

- * Can be used with TEMPCO-PAK or Tubing
- * Both types have Brass Ferrules



Standard Tube Adapters

Affords higher degree of stability to Plug or Jack

Sheath Diameter	Part Number
.040"	TCA-103-106
.063"	TCA-103-102
.125"	TCA-103-101
.188"	TCA-103-103
.250"	TCA-103-104
.313"	TCA-103-107
.375"	TCA-103-108

Insert Tube Adapter

Secured by slots in body of the Plug or Jack (2-Pin or 3-Pin)

Sheath Diameter	Part Number
.040"	TCA-103-109
.063"	TCA-103-110
.125"	TCA-103-111

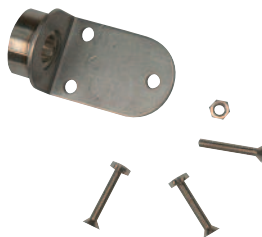

Stainless Steel Spool-Type Brazing Adapters

- * Provides maximum rigidity to Plug or Jack
- * For 2-Pin connectors only

Sheath Diameter	Part Number
Undrilled	TCA-113-109
.063"	TCA-113-110
.125"	TCA-113-111
.188"	TCA-113-112
.250"	TCA-113-113
.313"	TCA-113-114
.375"	TCA-113-115

Neoprene Boots for Standard Plug and Jack

- * Made of Flexible Neoprene
- * Sized to cover standard connectors even with accessories (such as Cable Clamps and Tube adapters)
- * 3/32" Wire Entrance
- * Order 2 per Assembly
- * 3/32" Wire Entrance
- * For 2-Pin Connections only

Part Number TCA-121-101

Brass Crimping/Brazing Inserts for Ultra-Temp Plugs & Jacks

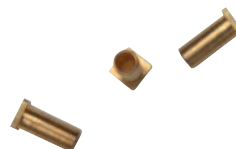

Sheath Diameter	Part Number
.040"	TCA-112-119
.062"	TCA-112-117
.125"	TCA-112-118
.188"	TCA-112-120
.250"	TCA-112-121

CONTINUED 

Accessories for Standard Plugs and Jacks

Continued from previous page...

Dual Tube Adapters

- * Assemble Standard Connectors into Dual Connectors
- * For adjacent TEMPCO-PAK
- * Has Brass Ferrule
- * Use 2-Pin Connectors only

Sheath Diameter	Part Number
.063"	TCA-103-112
.125"	TCA-103-113
.188"	TCA-103-114
.250"	TCA-103-115
.313"	TCA-103-116
.375"	TCA-103-117

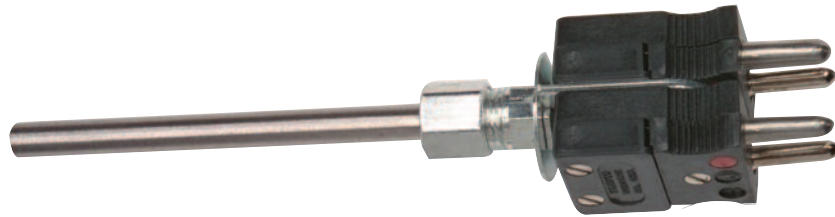

Dual Cable Clamps

- * Assemble Standard Connectors into Dual Connectors
- * Accommodate either One or Two Lead-In Cables
- * Use 2-Pin Connectors only

Part Number: **TCA-107-103**

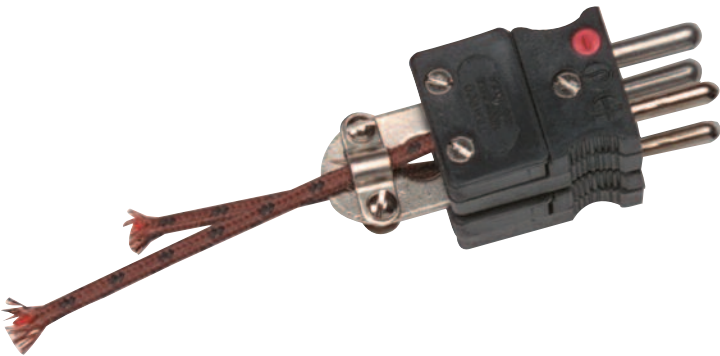

Thermocouple Bracket

- * Used to mount T/C Probes on Panel or Oven Walls
- * Supplied with two #6 Self-Tapping Screws

Part Number: **SMPR-1062**

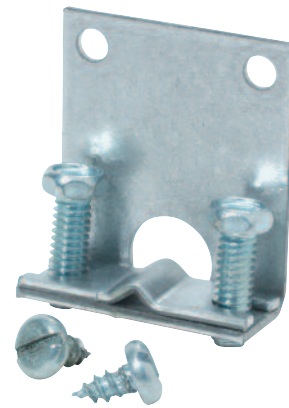

Filler Plate Set

- * When combined with Dual Tube Adapter or Dual Cable Clamp, the Filler Plate Set provides the 3/4" pin spacing of a single Duplex Connector.

Part Number: **TCA-107-104**

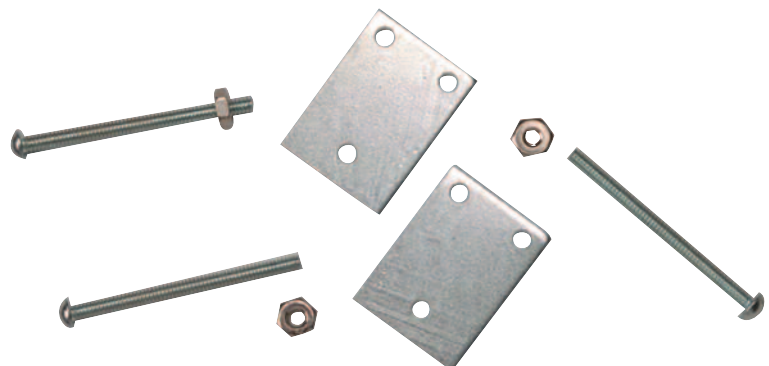

Accessories for Miniature Plugs and Jacks

Cable Clamps and Grommets

Cable Clamp (For 2-Pin Miniature)

Part Number: **TCA-107-105**

Cable Clamp (For 3-Pin Miniature)

Part Number: **TCA-107-109**

Neoprene Grommet

Part Number: **TCA-109-102**

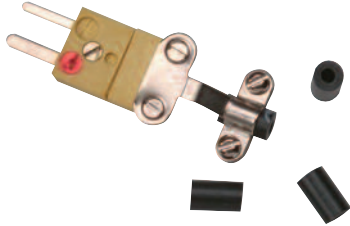

Neoprene Wire Entrance Grommets Nylon Wire Protection Washers

* For all Miniature Connectors

* Grommet is used in place of cable clamp

* Washer protects fine wire from breakage

Grommet

Part Number: **TCA-109-104**

Washer

Part Number: **TCA-120-102**

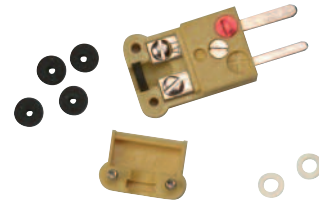

Crimping Inserts

* For all Miniature Connectors

* Used primarily with TEMPCO-PAK

Brazing Inserts

* For all Miniature Connectors

* Can be used with Tubing or TEMPCO-PAK

Sheath Diameter (in) (mm)	Part Number
Undrilled	TCA-112-111
.020 .50	TCA-112-112
.040 1.00	TCA-112-113
.063 1.60	TCA-112-114
.125 3.17	TCA-112-115
.188 4.77	TCA-112-116

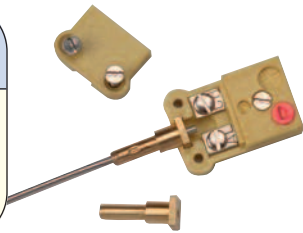

Sheath Diameter (in) (mm)	Part Number
Undrilled	TCA-113-116
.020 .50	TCA-113-117
.040 1.00	TCA-113-118
.063 1.60	TCA-113-119
.125 3.17	TCA-113-120
.188 4.77	TCA-113-121



Mini Insert Tube Adapter

* Secured by slots in body of the Plug or Jack (2-pin or 3-Pin)

* Compression Fitting has Brass Ferrules

* Can be used with TEMPCO-PAK or Tubing

* For all Miniature Connectors only

Sheath Diameter (in) (mm)	Part Number
.040 1.00	TCA-103-118
.063 1.60	TCA-103-119
.125 3.17	TCA-103-120

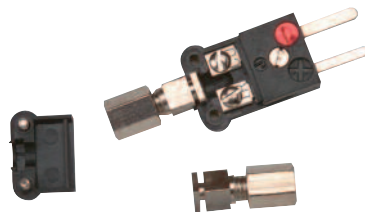

Neoprene Boot for Miniature Plug and Jack

* Made of Flexible Neoprene

* Sized to cover miniature connectors even with accessories (such as Cable Clamps and Tube Adapters)

* 3/32" Wire Entrance

* Order 2 per Assembly

* For 2-Pin Connections only

Part Number: **TCA-121-102**



Thermocouple Insulators

Oval—Double Hole Cordierite

Maximum Temperature: 2282°F (1250°C)

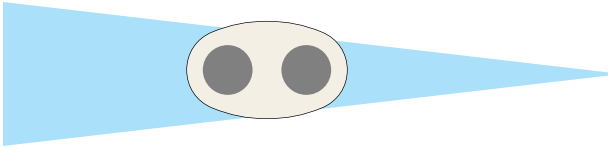

Part Number	Width (in)	Thickness (in)	Bore (in)	Max. B & S Gauge Size	Length (in)
COR-120-105	.437	.250	.156	7	1
COR-120-104	.375	.217	.110	10	1
COR-120-106	.172	.118	.042	19	1

Round—Single Hole Mullite

Maximum Temperature: 2900°F (1593°C)

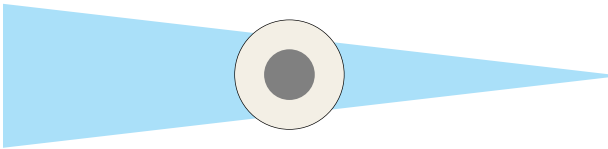

Part Number	Diameter (in)	Bore (in)	Max. B & S Gauge Size	Length (in)
COR-123-101	.062	.031	22	12
COR-123-102	.125	.062	16	12
COR-123-103	.187	.094	12	12

Round—Double Hole Alumina

Maximum Temperature: 3300°F (1815°C)

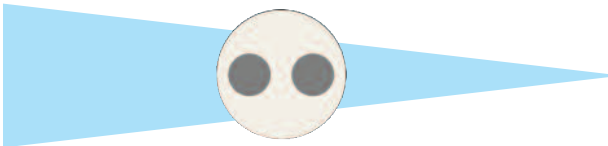

Part Number	Diameter (in)	Bore (in)	Max. B & S Gauge Size	Length (in)
COR-124-101	.125	.031	22	1
COR-124-102	.125	.031	22	2
COR-124-103	.125	.031	22	3
COR-124-104	.125	.031	22	12
COR-124-105	.062	.016	28	12
COR-124-106	.187	.040	20	12

Round—Double Hole Mullite

Maximum Temperature: 2400°F (1315°C)

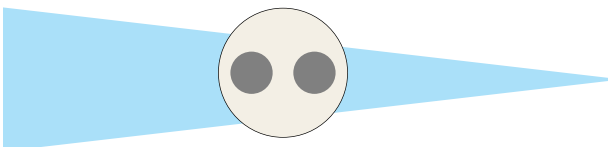

Part Number	Diameter (in)	Bore (in)	Max. B & S Gauge Size	Length (in)
COR-125-101	.156	.046	18	1
COR-125-102	.156	.046	18	3
COR-126-101	.250	.085	13	1
COR-126-102	.250	.085	13	3
*COR-127-101	.437	.156	7	1
*COR-127-102	.437	.156	7	3

*Material is Cordierite

Round—Four Hole Alumina

Maximum Temperature: 3300°F (1815°C)

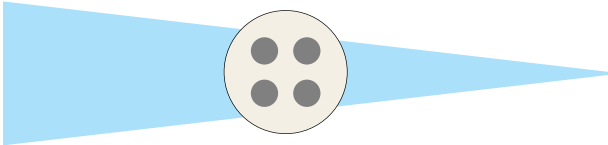

Part Number	Diameter (in)	Bore (in)	Max. B & S Gauge Size	Length (in)
COR-128-101	.187	.047	18	1
COR-128-102	.312	.078	13	1

Fish Spine—Ball and Socket Insulators—Steatite

Maximum Temperature: 2400°F (1315°C)

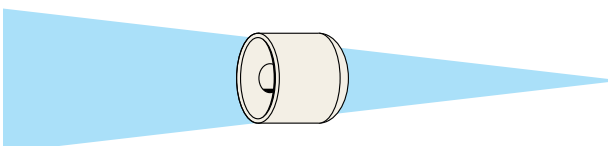

Part Number	Diameter (in)	Bore (in)	Max. B & S Gauge Size	Length (in)	Number of Pcs. per Sleeve
CER-103-101	.110	.056	16	.110	67 pcs/6"
CER-103-102	.170	.068	14	.170	86 pcs/12"
CER-103-104	.200	.092	12	.200	Bulk Loose
CER-103-105	.330	.124	9	.330	Bulk Loose
CER-103-106	.400	.156	7	.400	Bulk Loose
CER-103-109	.260	.156	7	.260	Bulk Loose

Open Disc Terminal Blocks

The open disc terminal blocks are available for both single and dual element thermocouples or single-element RTD assemblies. They are available in two different materials. Ceramic discs are rated for 1000°F (530°C) and silicone/glass fiber discs are rated for 350°F (117°C). Silicone glass/fiber has a higher resistance to vibration and thermal shock than do the ceramic discs.

Each disc is assembled to a 1" O.D. × 1/8" thick brass (standard) or optional stainless steel back-up plate by two screws, and the plate is directly brazed to the sensor sheath.

Ceramic Open Disc with Brass Back-Up Plate and Mounting Screws

Sheath O.D. (in)	Approximate Dimensions (in)	Part Number			Six Wire Approximate Dimensions (in)
		Single Element	Dual Element	Six Wire Element	
1/8	1 1/8 O.D. × 1/16 H	TCH10045	TCH10048	TCH10051	2 1/2 O.D. × 1/16 H
3/16	1 1/8 O.D. × 1/16 H	TCH10046	TCH10049	TCH10052	2 1/2 O.D. × 1/16 H
1/4	1 1/8 O.D. × 1/16 H	TCH10047	TCH10050	TCH10053	2 1/2 O.D. × 1/16 H

Ceramic Open Disc with Stainless Steel Back-Up Plate and Mounting Screws

Sheath O.D. (in)	Approximate Dimensions (in)	Part Number			Six Wire Approximate Dimensions (in)
		Single Element	Dual Element	Six Wire Element	
1/8	1 1/8 O.D. × 1/16 H	TCH10054	TCH10057	TCH10060	2 1/2 O.D. × 1/16 H
3/16	1 1/8 O.D. × 1/16 H	TCH10055	TCH10058	TCH10061	2 1/2 O.D. × 1/16 H
1/4	1 1/8 O.D. × 1/16 H	TCH10056	TCH10059	TCH10062	2 1/2 O.D. × 1/16 H

Silicone/Glass Fiber Open Disc with Brass Back-Up Plate and Mounting Screws

Sheath O.D. (in)	Approximate Dimensions (in)	Part Number	
		Single Element	Dual Element
1/8	1" O.D. × 1/16 H	TCH10063	N/A
3/16	1" O.D. × 1/16 H	TCH10064	N/A
1/4	1" O.D. × 1/16 H	TCH10065	N/A

Silicone/Glass Fiber Open Disc with Stainless Steel Back-Up Plate and Mounting Screws

Sheath O.D. (in)	Approximate Dimensions (in)	Part Number	
		Single Element	Dual Element
1/8	1" O.D. × 1/16 H	TCH10066	N/A
3/16	1" O.D. × 1/16 H	TCH10067	N/A
1/4	1" O.D. × 1/16 H	TCH10068	N/A

Ceramic Disc for Single Element



P/N: TCA-110-126

Ceramic Disc for Dual Elements

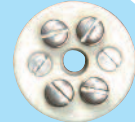

P/N: TCA-110-127

Silicone/Glass Fiber for Single Element Only

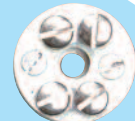

P/N: TCA-110-128

Ceramic Disc for Six Wire



P/N: TCA-110-129

Die Cast Aluminum Heads

Design Features:

- * Plated chain attaches cover to body
- * Body is O-ring gasketed
- * Available in 2-terminal or 4-terminal
- * Comes in three sizes—Standard, Medium and Miniature—to allow for design flexibility
- * Has grommeted conduit entry for lead wire or flexible cable

Type "A" Standard Size Die Cast Aluminum Head



3-1/2"H x 4"L x 3-1/4"W



2-Terminal Ceramic Block
P/N: **TCA-116-101**

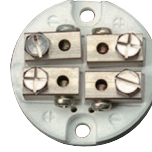

4-Terminal Ceramic Block
P/N: **TCA-116-102**

Sensor Opening (FNPT)	Conduit Opening (FNPT)	Part Number		
		Head Only	Head with 2-Terminal	Head with 4-Terminal
1/4"	1/2"	TCA-110-104	TCH10001	TCH10003
1/2"	1/2"	TCA-110-105	TCH10002	TCH10004

Type "B" Medium Die Cast Aluminum Head

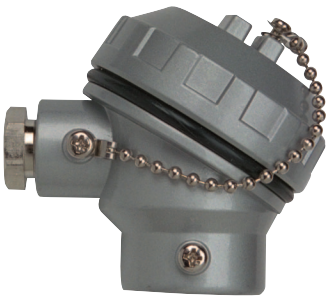

3-1/2"H x 3-3/4"L x 2-5/8"W

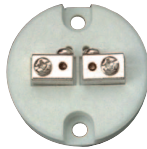

2-Terminal Ceramic Block
P/N: **TCA-116-103**



4-Terminal Ceramic Block
P/N: **TCA-116-104**

Sensor Opening (FNPT)	Conduit Opening (FNPT)	Part Number		
		Head Only	Head with 2-Terminal	Head with 4-Terminal
1/2"	3/8"	TCA-110-106	TCH10005	TCH10008
3/8"	3/8"	TCA-110-107	TCH10006	TCH10009
1/4"	3/8"	TCA-110-108	TCH10007	TCH10010

Type "C" Miniature Die Cast Aluminum Head

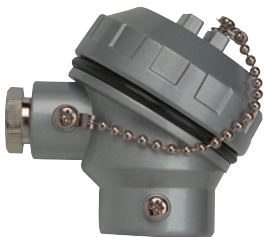

2-5/8"H x 3"L x 2-5/16"W



2-Terminal Ceramic Block
P/N: **TCA-116-105**

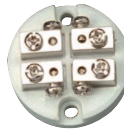

4-Terminal Ceramic Block
P/N: **TCA-116-106**

Sensor Opening (FNPT)	Conduit Opening (FNPT)	Part Number		
		Head Only	Head with 2-Terminal	Head with 4-Terminal
1/2"	3/8"	TCA-110-109	TCH10011	TCH10014
3/8"	3/8"	TCA-110-110	TCH10012	TCH10015
1/4"	3/8"	TCA-110-111	TCH10013	TCH10016

Type "H" Standard Cast Iron Head



Approximate Size
3-1/2"H x 3-1/2"L x 3-1/2"W

Design Features:

- * Stainless Steel chain and screws
- * High temperature painted finish
- * Neoprene rubber O-ring for weatherproof seal

Terminal Blocks

Can use terminal blocks from Type A and Type B Head (page 14-98), and Spring-Loaded (page 14-100)

Sensor Opening (FNPT)	Conduit Opening (FNPT)	Part Number
1/2"	1/2"	TCA-110-152
1/2"	3/4"	TCA-110-153
3/4"	3/4"	TCA-110-158

Bakelite Series

Design Features:

- * Lightweight
- * Non-combustible, Acid and Alkali resistant body
- * Maximum service temperature of 662°F (350°C)
- * Plated chain attaches cover to body
- * Body is O-ring gasketed
- * Available in 2-Terminal or 4-Terminal
- * Has grommeted conduit entry for lead wire or flexible cable
- * Available in two sizes: Standard and Small

Type "F" Standard Size Bakelite Head



Bakelite
2-Terminal Block
P/N: TCA-116-111

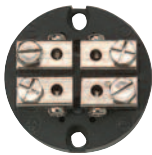

Bakelite
4-Terminal Block
P/N: TCA-116-112



Approximate Size:
3-7/8"H x 4-1/8"L x 3-3/16"W

Sensor Opening (FNPT)	Conduit Opening (FNPT)	Part Number		
		Head Only	Head with 2-Terminal	Head with 4-Terminal
1/2"	1/2"	TCA-110-124	TCH10041	TCH10042

Type "G" Miniature Size Bakelite Head



Bakelite
2-Terminal Block
P/N: TCA-116-113



Bakelite
4-Terminal Block
P/N: TCA-116-114



Approximate Size:
2-5/8"H x 3"L x 2-5/16"W

Sensor Opening (FNPT)	Conduit Opening (FNPT)	Part Number		
		Head Only	Head with 2-Terminal	Head with 4-Terminal
1/4"	3/8"	TCA-110-125	TCH10043	TCH10044

Temperature Sensing



Thermocouple Accessories

Type P Polypropylene Head

Design Features:

- * FDA approved white polypropylene for food industry
- * Screw cover head with stainless steel chain and screws
- * 1/2" NPT process connection and 3/4" NPT conduit connection



P/N: TCA-110-147

Terminal Blocks

Can use terminal blocks from Type A and Type B Head (page 14-98), and Type F Head (page 14-99)

Approximate Size:
3-1/4"H x 3-1/2"L x 3-1/4"W

Type S Stainless Steel Head

Design Features:

- * 316 Stainless Steel body
- * Stainless Steel chain and screws
- * Neoprene rubber O-ring for weatherproof seal

Terminal Blocks

Can use terminal blocks from Type A and Type B Head (page 14-98), and Spring-Loaded (below)

Approximate Size:
3-1/2"H x 3-1/2"L x 3"W



Sensor Opening (FNPT)	Conduit Opening (FNPT)	Part Number
1/2"	1/2"	TCA-110-154
1/2"	3/4"	TCA-110-155

Type N Miniature Nickel-Plated Steel Head



Approximate Size:
1-1/8" Dia. x 2-3/8"L

Design Features:

- * 2- or 4-terminal block included
- * 1/8" NPT or 1/4" NPT Process opening
- * Neoprene Cap Grommet for wire entry

Part Number	Thread Size	Number of Terminals
TCA-110-146	1/4 NPT	2
TCA-110-148	1/4 NPT	4
TCA-110-149	1/8 NPT	2
TCA-110-150	1/8 NPT	4

Spring-Loaded Terminal Blocks

- * Used on spring-loaded assemblies
- * Ceramic with nickel-plated brass terminals
- * Steel plate for mounting
- * Can be used with Type A, B, F, H, P and S Heads



2-Terminal Block

P/N: TCA-116-116



4-Terminal Block

P/N: TCA-116-119



3-Terminal Block

P/N: TCA-116-122



6-Terminal Block

P/N: TCA-116-120

Screw Terminal Barrier Blocks for Thermocouples

Design Features:

- * Made of Glass-Filled Nylon, 350°F (177°C) max.
- * 250 VAC RMS max. Voltage Rating, 20 Amps max.
- * Supplied with 6-32 Terminal Screws
- * Available with Nickel-Plated Copper Lugs, Thermocouple Compensating Lugs or No Lugs

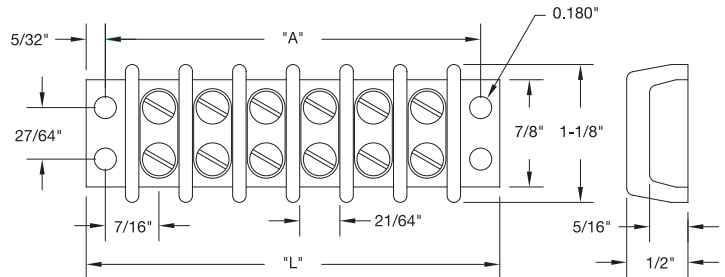

Ordering Code: **TBS** - ¹ ²

No. of Terminals BOX 1
Enter **02 to 20**
(See table for available Number of Terminals)

Type of Lugs BOX 2
00 = No Lugs, Screws Supplied
10 = Nickel-Plated Copper Lugs
1 = With Thermocouple Compensating Lugs
Enter Calibration

Number of Terminals	"A" Dim. (inches)	"L" Dim. (inches)
2	1.31	1.63
3	1.75	2.06
4	2.19	2.50
6	3.06	3.38
8	3.94	4.25
10	4.81	5.13
12	5.69	6.00
14	6.56	6.88
16	7.44	7.75
20	9.19	9.50

Plastic Melt Bolts

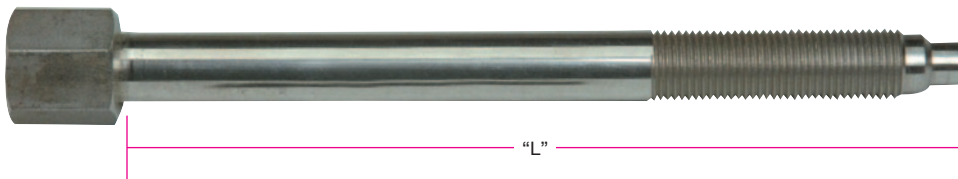

The Blank Bolt is used to seal hole if thermocouple is removed from extruder.

NOTE: All bolts except Blank Bolts are drilled to accept 1/8" diameter thermocouple.

Detailed Dimensions for Plastic Melt Bolts

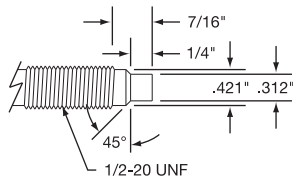

Bolt-Tip Dimensions

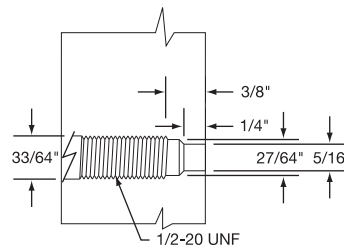

Recommended drilling dimensions for proper mounting in extruder

Styles R & F are shown on Pages 14-10 and 14-11

Length "L"	Blank	With 1/8" Diameter Hole	With Teflon® Insert	To make Style "R" *	To make Style "R" w/Teflon® insert *	To make Style "F"	To make Style "F" w/Teflon® Insert
3" **	FAS-116-101	FAS-116-103	FAS-116-105	FAS-116-107	FAS-116-109	FAS-116-111	FAS-116-113
6" **	FAS-116-102	FAS-116-104	FAS-116-106	FAS-116-108	FAS-116-110	FAS-116-112	FAS-116-114

* Includes hardware to mount plug

** 300 series stainless steel

⚠ WARNING: Cancer and Reproductive Harm - www.P65Warnings.ca.gov.

(800) 323-6859 • Email: sales@tempco.com

Thermocouple Wire and Thermocouple Extension Wire



- ◆ **Insulated Thermocouple and Extension Wire Insulation Types** — See Page 14-104
- ◆ **Thermocouple Wire and Extension Grade Thermocouple Wire Color Codes** — See Pages 14-105 and 14-106
- ◆ **Thermocouple Grade Wire** — See Pages 14-107 through 14-109
- ◆ **Thermocouple Extension Grade Wire** — See Pages 14-110 and 14-111
- ◆ **Coil Cords and RTD Wires** — See Page 14-112

Using Thermocouple Extension Wire

Thermocouple extension wire is often used to make the connection between the thermocouple and the measuring instrument, especially when long distances are involved, due to its cost advantage. Thermocouple extension wire has approximately the same characteristics as thermocouple wire but its accuracy is guaranteed over a more limited range of temperatures.

For base metal thermocouples, extension wire is of essentially the same composition as the corresponding thermocouple wire. Because of the high cost of noble metals, noble metal thermocouple extension wires are made from alloys that match the noble metal thermocouple characteristics.



Note: Thermocouple Extension Wire should never be used in place of thermocouple wire as the actual sensor because it will not generate accurate temperature information.

Protective Wraps for Thermocouple Wire and Thermocouple Extension Wire

Many of the insulated thermocouple wire and extension wire constructions listed on the following pages are available with the following two wraps as an option.



Stainless Steel or Tinned Copper Overbraid



Stainless Steel Wrap



Tolerances and Temperatures

Table 1 Tolerances on Initial Values of Emf vs. Temperature

- NOTE 1** Tolerances in this table apply to new essentially homogeneous thermocouple wire, normally in the size range 0.25 mm to 3 mm in diameter (No. 30 to No. 8 Awg) and used at temperatures not exceeding the recommended limits of Table 2. If used at higher temperatures these tolerances may not apply.
- NOTE 2** The Fahrenheit tolerance is 1.8 times larger than the °C tolerance at the equivalent °C temperature. Note particularly that percentage tolerances apply only to temperatures that are expressed in °C.
- NOTE 3** **Caution:** Users should be aware that certain characteristics of thermocouple materials, including the emf versus temperature relationship, may change with time in use; consequently, test results and performance obtained at time of manufacture may not necessarily apply throughout an extended period of use. Tolerances given in this table apply only to new wire or MI cable or thermocouples as delivered to the user and **do not allow for changes in characteristics with use.** The magnitude of such changes will depend on such factors as wire size, temperature, time of exposure, and environment. It should be further noted that due to possible changes in homogeneity, attempting to recalibrate **used** thermocouples is likely to yield irrelevant results, and is not recommended. However, it may be appropriate to compare used thermocouples **in-situ** with new or known good ones to ascertain their suitability for further service under the conditions of the comparison.

Thermocouple Type	Temperature Range		Tolerances—Reference Junction 0°C (32°F)			
			Standard Tolerances		Special Tolerances	
	°C	°F	°C (whichever is greater)		°C (whichever is greater)	
T	0 to 370	32 to 700	±1 or ±0.75%	Note 2	±0.5 or 0.4%	Note 2
J	0 to 760	32 to 1400	±2.2 or ±0.75%		±1.1 or 0.4%	
E	0 to 870	32 to 1600	±1.7 or ±0.5%		±1 or ±0.4%	
K or N	0 to 1260	32 to 2300	±2.2 or ±0.75%		±1.1 or ±0.4%	
R or S	0 to 1480	32 to 2700	±1.5 or ±0.25%		±0.6 or ±0.1%	
B	870 to 1700	1600 to 3100	±0.5%			
T ^A	-200 to 0	-328 to 32	±1 or ±1.5%		B	
E ^A	-200 to 0	-328 to 32	±1.7 or ±1%		B	
K ^A	-200 to 0	-328 to 32	±2.2 or ±2%		B	

^A Thermocouples and thermocouple materials are normally supplied to meet the tolerances specified in the table for temperatures above 0°C. The same materials, however, may not fall within the tolerances given for temperatures below 0°C in the second section of the table. If materials are required to meet the tolerances stated for temperatures below 0°C the purchase order must so state. Selection of materials usually will be required.

^B Special tolerances for temperatures below 0°C are difficult to justify due to limited available information. However, the following values for Types E and T thermocouples are suggested as a guide for discussion between purchaser and supplier:

Type E -200 to 0°C ±1°C or ±0.5% (whichever is greater) **Type T** -200 to 0°C ±0.5°C or ±0.8% (whichever is greater)

Initial values of tolerance for Type J thermocouples at temperatures below 0°C and special tolerances for Type K thermocouples below 0°C are not given due to the characteristics of the materials.

Table 2 Suggested Upper Temperature Limits for Protected Thermocouples





- NOTE 1** This table gives the recommended upper temperature limits for the various thermocouples and wire sizes. These limits apply to protected thermocouples: that is, thermocouples in conventional closed-end protection tubes. They do not apply to sheathed thermocouples having compacted mineral oxide insulation.
- NOTE 2** The temperature limits given here are intended only as a guide to the user and should not be taken as absolute values nor as guarantees of satisfactory life or performance. These types and sizes are sometimes used at temperatures above the given limits, but usually at the expense of stability or life or both. In other instances, it may be necessary to reduce the given limits in order to achieve adequate service. ASTM MNL-12^c and other literature sources should be consulted for additional application information.

Thermocouple Type	Upper Temperature Limit for Various Wire Sizes (Awg), °C (°F)					
	No. 8 Gauge 3.25 mm (0.128 in)	No. 14 Gauge 1.63 mm (0.064 in)	No. 20 Gauge 0.81 mm (0.032 in)	No. 24 Gauge 0.51 mm (0.020 in)	No. 28 Gauge 0.33 mm (0.013 in)	No. 30 Gauge 0.25 mm (0.010 in)
T		370 (700)	260 (500)	200 (400)	200 (400)	150 (300)
J	760 (1400)	590 (1100)	480 (900)	370 (700)	370 (700)	320 (600)
E	870 (1600)	650 (1200)	540 (1000)	430 (800)	430 (800)	370 (700)
K and N	1260 (2300)	1090 (2000)	980 (1800)	870 (1600)	870 (1600)	760 (1400)
R and S				1480 (2700)		
B				1700 (3100)		

^c "Manual on the Use of Thermocouples in Temperature Measurement," ASTM MNL-12, 1993.

Tables courtesy ASTM

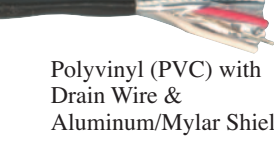
Insulated Thermocouple and Extension Wire Insulation Types

	Single Conductor		Duplex Conductors		Temperature Rating†		ANSI Color Coded	Physical Properties		
	Insulation	Impregnation	Insulation	Impregnation	Continuous	Single Reading		Abrasion Resist.	Moisture Resist.	Chemical Resist.
 Glass Braid	Glass Braid	Silicone Modified Resin (retained to 400°F [204°C])	Glass Braid	Silicone Modified Resin (retained to 400°F [204°C])	900°F (482°C)	1000°F (538°C)	Yes	Fair	Good	Good
 Double Glass Wrap	Double Glass Wrap	Silicone Modified Resin (retained to 400°F [204°C])	Glass Braid	Silicone Modified Resin (retained to 400°F [204°C])	900°F (482°C)	1000°F (538°C)	Yes	Fair	Good	Good
 High Temperature Glass Braid	High Temp Glass Braid	High Temp Varnish (retained to 400°F [204°C])	High Temp Glass Braid	High Temp Varnish	1300°F (704°C)	1600°F (871°C)	Yes	Good	Fair	Good
 Polyvinyl (PVC)	Polyvinyl (PVC)	—	Polyvinyl (PVC)	—	-20 to +221°F (-29 to 105°C)	221°F (105°C)	Yes	Good	Excellent	Good
 FEP Extr.	FEP Extr.	—	FEP Extr.	—	400°F (204°C)	500°F (260°C)	Yes	Excellent	Excellent	Excellent
 Kapton®	Kapton®	—	Kapton®	—	500°F (260°C)	800°F (427°C)	Yes (Indiv. only)	Excellent	Excellent	Excellent
 Polyvinyl (PVC) with Drain Wire & Aluminum/Mylar Shield	Polyvinyl (PVC)	—	Polyvinyl (PVC) Twisted	—	-20 to +221°F (-29 to +105°C)	221°F (105°C)	Yes	Good	Excellent	Good
 Vitreous Silica Fiber	Vitreous Silica Fiber	—	Vitreous Silica Fiber	—	1600°F (871°C)	2000°F (1093°C)	No	Fair	Fair	Good
 Ceramic Fiber	Ceramic Fiber	—	Ceramic Fiber	—	2200°F (1204°C)	2600°F (1427°C)	No	Good	Fair	Good







†Thermocouple extension grade wire is only calibrated up to 400°F (204°C).

Thermocouple Wire Color Code & Specifications (United States, Canada & Mexico)

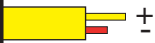
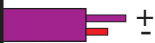

ANSI Code	Color Code	Positive (+) Lead	Negative (-) Lead	Temperature Range	Initial Calibration Tolerances	
					Standard °C (whichever is greater)	Special °C (whichever is greater)
J		Iron	Constantan (45% Nickel, 55% Copper)	32-1382°F (0-750°C)	±2.2°C or ±0.75%	±1.1°C or ±0.4%
K		Chromel® (90% Nickel, 10% Chromium)	Alumel (95% Nickel, 2% Aluminum, 2% Manganese, 1% Silicon)	32-2282°F (0-1250°C)	±2.2°C or ±0.75%	±1.1°C or ±0.4%
E		Chromel® (90% Nickel, 10% Chromium)	Constantan (45% Nickel, 55% Copper)	32-1652°F (0-900°C)	±1.7°C or ±0.5%	±1.0°C or ±0.4%
T		Copper	Constantan (45% Nickel, 55% Copper)	32-662°F (0-350°C)	±1°C or ±0.75%	±.5°C or ±0.4%
N		Nicrosil (84.6% Nickel, 14% Chromium, 1.4% Silicon)	Nisil (95.6% Nickel, 4.4 % Silicon)	32-2282°F (0-1250°C)	±2.2°C or ±0.75%	±1.1°C or ±0.4%

Thermocouple Extension Wire Color Code & Specifications (United States, Canada & Mexico)

ANSI Code	ANSI Color Code	Positive (+) Lead	Negative (-) Lead	Temperature Range	Initial Calibration Tolerances	
					Standard	Special
JX		Iron	Constantan (45% Nickel, 55% Copper)	32-392°F (0-200°C)	±2.2°C	±1.1°C
KX		Chromel® (90% Nickel, 10% Chromium)	Alumel (95% Nickel, 2% Aluminum, 2% Manganese, 1% Silicon)	32-392°F (0-200°C)	±2.2°C	±1.1°C
EX		Chromel® (90% Nickel, 10% Chromium)	Constantan (45% Nickel, 55% Copper)	32-392°F (0-200°C)	±1.7°C	±1.1°C
TX		Copper	Constantan (45% Nickel, 55% Copper)	32 to 212°F (0-100°C)	±1.0°C	±0.5°C
NX		Nicrosil (84.6% Nickel, 4% Chromium, 1.4 % Silicon)	Nisil (95.6% Nickel, 4.4 % Silicon)	32-392°F (0-200°C)	±2.2°C	±1.1°C
Compensating Extension Wire Type						
RX*		Copper	Copper Alloy	32-392°F (0-200°C)	±9°F (±5°C)	N/A
SX*		Copper	Copper Alloy	32-392°F (0-200°C)	±9°F (±5°C)	N/A
BX†*		Copper	Copper	32 to 212°F (0-100°C)	+0°F -6.7°F (+0°C -3.7°C)	N/A

* Due to the non-linearity of the types R, S, and B temperature-emf curves, the error introduced into a thermocouple system by the compensating wire will be variable when expressed in degrees. The degree C tolerances are based on the following measuring junction temperatures.

†Copper versus copper compensating extension wire, usable to 100°C (212°F) with maximum deviations as indicated, but with no significant deviation over 0°C to 50°C (32°F to 122°F) range.

Type Wire	Measuring Junction Temperature
SX	Greater than 1598°F (870°C)
BX	Greater than 1832°F (1000°C)

Thermocouple Tolerances and Calibration

ANSI Tolerances

All thermocouple wire and extension wire is supplied to meet Standard Tolerances of ANSI Circular MC96.1–1982. Special tolerances are also available per ANSI MC96.1 at an extra charge. The standard and special tolerances for thermocouple and extension wires are given in the accompanying tables — see pages 14-103 and 14-105. Where tolerances are given in percent, the percentage applies to the temperature being measured.

Calibration and Certification

Thermocouple wire and elements can be factory calibrated and certified at an extra charge. Each thermocouple, coil, reel, or spool of wire is then tagged to show the individual departure from curve. The normal calibrating temperature range is 32°F–2000°F (0°C–1093°C), depending on wire type, gauge size and insulation type. A certificate of calibration is furnished upon request for all calibrated items. Each item calibrated is also tagged with the results.

ANSI Type J Duplex Thermocouple Wire

ANSI color code—White positive/Red negative—Over All Brown

“J” Thermocouple Wire – Stocked on 100 and 250 Foot Spools



TC Type	Wire Type	Insulation	Insulation Temperature Limits (°F/°C)	Nominal Overall Dimensions (inches)	Part Number	
					100 Foot Spool	250 Foot Spool
J	20 Gauge Solid	Fiberglass	900/482	.060 × .106	TCWR-1028	TCWR-1032
J	20 Gauge Stranded	Fiberglass	900/482	.066 × .118	TCWR-1033	TCWR-1035
J	24 Gauge Solid	Fiberglass	900/482	.048 × .082	TCWR-1037	TCWR-1069
J	24 Gauge Stranded	Fiberglass	900/482	.048 × .082	TCWR-1038	TCWR-1070
J	20 Gauge Stranded	Fiberglass with SS overbraid	900/482	.088 × .140	TCWR-1047	TCWR-1051
J	20 Gauge Solid	FEP Teflon®	400/204	.068 × .116	TCWR-1060	TCWR-1062
J	24 Gauge Stranded	Fiberglass with SS overbraid	900/482	.074 × .100	TCWR-1048	TCWR-1052

“J” Thermocouple Wire – Order Length Required (50 Foot Minimum)

B & S ga.	Wire Type	Insulation Over All	Insulation Each Conductor	Maximum Temp.		Nominal Overall Dimensions (inches)	Part Number
				°F	°C		
16	Solid	Glass Braid	Glass Braid	900	482	.080 × .144	TCW-101-123
18	Stranded (7/26)	Glass Braid w/ SS Braid O/A	Glass Braid	900	482	.122 × .175	TCW-101-130
20	Solid	Hi-temp Glass Braid	Hi-temp Glass Braid	1400	760	.086 × .136	TCW-101-115
20	Solid	Amber colored Kapton® tape	Color coded Kapton® tape	500	260	.055 × .099	TCW-101-112
20	Stranded (7/28)	Kapton®	Kapton®	500	260	.058 × .108	TCW-101-131
24	Solid	Glass Braid	Double Glass wrap	900	482	.043 × .074	TCW-101-113
24	Solid	Rip-cord construction	PVC (extruded)	221	105	.046 × .092	TCW-101-116
24	Solid	Glass Braid w/ SS Braid	Glass Braid	900	482	.074 × .100	TCW-101-119
30	Solid	Glass Braid	Double Glass wrap	900	482	.033 × .054	TCW-101-114

Insulated Thermocouple Wire

ANSI Type J Single Conductor Construction Thermocouple Wire

Individual wires ANSI color code—Negative (JN) wire Red—Positive (JP) wire White

B & S ga.	Conductor Type	Nominal O.D. (inches)	Wire Type	Insulation Each Conductor	Max. Temp		Part Number
					°F	°C	
20	Iron (JP)	.050"	Stranded	Glass Braid	900	482	TCW-104-105
20	Constantan (JN)	.050"	Stranded	Glass Braid	900	482	TCW-105-105
24	Iron (JP)	.036"	Stranded	Glass Braid	900	482	TCW-104-106
24	Constantan (JN)	.036"	Stranded	Glass Braid	900	482	TCW-105-106

ANSI Type K Duplex Insulated Thermocouple Wire

ANSI color code—Yellow positive/Red negative—Over All Brown

“K” Thermocouple Wire — Stocked on 100 and 250 Foot Spools



TC Type	Wire Type	Insulation	Insulation Temperature Limits (°F/°C)	Nominal Overall Dimensions (inches)	Part Number	
					100 Foot Spool	250 Foot Spool
K	20 Gauge Solid	Fiberglass	900/482	.060 × .116	TCWR-1025	TCWR-1029
K	20 Gauge Stranded	Fiberglass	900/482	.066 × .118	TCWR-1034	TCWR-1036
K	24 Gauge Solid	Fiberglass	900/482	.044 × .074	TCWR-1039	TCWR-1071
K	24 Gauge Stranded	Fiberglass	900/482	.050 × .082	TCWR-1040	TCWR-1072
K	20 Gauge Stranded	Fiberglass with SS overbraid	900/482	.088 × .140	TCWR-1049	TCWR-1053
K	20 Gauge Solid	FEP Teflon®	400/204	.068 × .116	TCWR-1061	TCWR-1063
K	24 Gauge Stranded	Fiberglass with SS overbraid	900/482	.074 × .100	TCWR-1050	TCWR-1054

“K” Thermocouple Wire — Order Length Required (50 Foot Minimum)

B & S ga.	Wire Type	Insulation Over All	Insulation Each Conductor	Maximum Temp.		Nominal Overall Dimensions (inches)	Part Number
				°F	°C		
20	Solid	Hi-temp Glass Braid	Hi-temp Glass Braid	1400	760	.086 × .136	TCW-103-113
20	Solid	Amber colored Kapton® tape	Color coded Kapton® tape	500	260	.055 × .099	TCW-103-110
24	Solid	Glass Braid	Double Glass wrap	900	482	.043 × .074	TCW-103-111
24	Solid	Rip-cord construction	PVC (extruded)	221	105	.046 × .092	TCW-103-116
24	Solid	FEP Teflon®	FEP Teflon®	400	204	.056 × .092	TCW-103-123
24	Solid	Glass Braid w/ SS Braid	Glass Braid	900	482	.074 × .100	TCW-103-117
30	Solid	Glass Braid	Double Glass wrap	900	482	.033 × .054	TCW-103-112

ANSI Type K Special Limits Duplex Insulated Thermocouple Wire

B & S ga.	Wire Type	Insulation Over All	Insulation Each Conductor	Maximum Temp.		Nominal Overall Dimensions (inches)	Part Number
				°F	°C		
20	Solid	<i>NOT COLOR CODED</i> Vitreous Silica Braid	<i>NOT COLOR CODED</i> Vitreous Silica Braid	1600-2300	871-1260	.092 × .154	TCW-103-114
20	Solid	<i>NOT COLOR CODED</i> Ceramic Fiber Braid	<i>NOT COLOR CODED</i> Ceramic Fiber Braid	2200-2600	1204-1427	.092 × .154	TCW-103-115



ANSI Type N Duplex Construction Insulated Thermocouple Wire

ANSI color code—Orange positive/Red negative—Brown Over All

B & S ga.	Wire Type	Insulation Over All	Insulation Each Conductor	Maximum Temp.		Nominal Overall Dimensions (inches)	
				°F	°C		
20	Solid	Glass Braid	Glass Braid	900	482	.066 × .118	TCW-118-101
20	Solid	<small>NOT COLOR CODED</small> Vitreous Silica Braid	<small>NOT COLOR CODED</small> Vitreous Silica Braid	1600-2300	871-1260	.092 × .154	TCW-118-102
24	Solid	Glass Braid	Glass Braid	900	482	.043 × .074	TCW-118-103

ANSI Type T Duplex Construction Insulated Thermocouple Wire

ANSI color code—Blue positive/Red negative—Brown Over All

B & S ga.	Wire Type	Insulation Over All	Insulation Each Conductor	Maximum Temp.		Nominal Overall Dimensions (inches)	Part Number
				°F	°C		
20	Stranded (7/28)	FEP Teflon®	FEP Teflon®	400	204	.074 × .128	TCW-113-105
20	Solid	Glass Braid	Glass Braid	900	482	.060 × .106	TCW-113-101
20	Solid	Extruded (FEP) Teflon®	Extruded (FEP) Teflon®	400	204	.068 × .116	TCW-113-102
24	Solid	Polyvinyl (PVC)	Polyvinyl (PVC)	221	105	.046 × .092	TCW-113-103
24	Solid	Extruded (FEP) Teflon®	Extruded (FEP) Teflon®	400	204	.056 × .092	TCW-113-104

ANSI Type E and Chromel/Constantan Duplex Construction Thermocouple Wire

ANSI color code—Purple positive/Red negative—Brown Over All

B & S ga.	Wire Type	Insulation Over All	Insulation Each Conductor	Maximum Temp.		Nominal Overall Dimensions (inches)	Part Number
				°F	°C		
20	Solid	Glass Braid	Glass Braid	900	482	.060 × .106	TCW-121-101
20	Solid	TFE Teflon® tape	TFE Teflon® tape	500	260	.060 × .104	TCW-121-102
20	Stranded (7/28)	Glass Braid	Glass Braid	900	482	.066 × .118	TCW-121-103
20	Stranded (7/28)	Glass Braid	Double Glass wrap	900	482	.061 × .110	TCW-121-104

Ordering Information

Order by **Part Number** for wire stocked on standard 100 and 250 foot spools.
 Order by **Part Number** and **Length** in feet required (50 feet minimum) for wire not stocked on standard spools.

⚠ WARNING: Cancer and Reproductive Harm - www.P65Warnings.ca.gov.

ANSI Type JX Thermocouple Extension Wire

Duplex construction—ANSI color code—White positive/Red negative— Black Over All

“JX” Thermocouple Extension Wire — Stocked on 100 and 250 Foot Spools

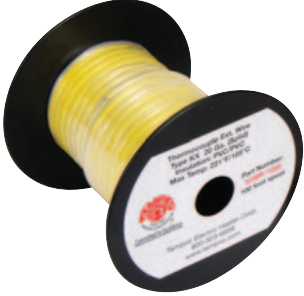

TC Type	Wire Type	Insulation	Insulation Temperature Limits (°F/°C)	Nominal Overall Dimensions (inches)	Part Number	
					100 Foot Spool	250 Foot Spool
JX	20 Gauge Solid	PVC	221/105	.092 x .154	TCWR-1027	TCWR-1031
JX	20 Gauge Stranded	PVC	221/105	.098 x .166	TCWR-1041	TCWR-1073
JX	24 Gauge Solid	PVC	221/105	.080 x .130	TCWR-1042	TCWR-1074
JX	24 Gauge Stranded	PVC	221/105	.084 x .138	TCWR-1043	TCWR-1075
JX	20 Gauge Solid	PVC with Shield & Drain	221/105	.169 Diameter	TCWR-1055	TCWR-1057

“JX” Thermocouple Extension Wire — Order Length Required (50 Foot Minimum)

B & S ga.	Wire Type	Insulation Over All	Insulation Each Conductor	Maximum Temp.		Nominal Overall Dimensions (inches)	Part Number
				°F	°C		
16	Solid	Polyvinyl (PVC)	Polyvinyl (PVC)	221	105	.111 x .192	TCW-102-105
16	Solid	PVC/twisted w/ alum Mylar tape shield & bare drain wire	Polyvinyl (PVC)	221	105	.207 x round	TCW-102-106

ANSI Type KX Duplex Construction Insulated Thermocouple Extension Wire

ANSI color code—Yellow positive/Red negative— Yellow Over All

“KX” Thermocouple Extension Wire — Stocked on 100 and 250 Foot Spools

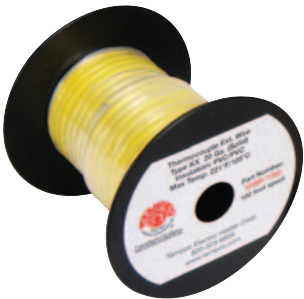

TC Type	Wire Type	Insulation	Insulation Temperature Limits (°F/°C)	Nominal Overall Dimensions (inches)	Part Number	
					100 Foot Spool	250 Foot Spool
KX	20 Gauge Solid	PVC	221/105	.092 x .154	TCWR-1026	TCWR-1030
KX	20 Gauge Stranded	PVC	221/105	.098 x .166	TCWR-1044	TCWR-1076
KX	24 Gauge Solid	PVC	221/105	.080 x .130	TCWR-1045	TCWR-1077
KX	24 Gauge Stranded	PVC	221/105	.084 x .138	TCWR-1046	TCWR-1078
KX	20 Gauge Solid	PVC with Shield & Drain	221/105	.169 Diameter	TCWR-1056	TCWR-1058

“KX” Thermocouple Extension Wire — Order Length Required (50 Foot Minimum)

B & S ga.	Wire Type	Insulation Over All	Insulation Each Conductor	Maximum Temp.		Nominal Overall Dimensions (inches)	Part Number
				°F	°C		
20	Stranded (7/28)	PVC/twisted w/alum. mylar tape shield & bare drain wire	Polyvinyl (PVC)	221	105	.181 round	TCW-117-105



ANSI Type NX Duplex Construction Insulated Thermocouple Extension Wire

ANSI color code—Orange positive/Red negative—Orange Over All

B & S ga.	Wire Type	Insulation Over All	Insulation Each Conductor	Maximum Temp.		Nominal Overall Dimensions (inches)	Part Number
				°F	°C		
20	Solid	Polyvinyl (PVC)	Polyvinyl (PVC)	221	105	.092 × .154	TCW-119-101
20	Solid	PVC/twisted w/ alum. mylar tape shield & bare drain wire	Polyvinyl (PVC)	221	105	.098 × .166	TCW-119-102

ANSI Type TX Duplex Construction Insulated Thermocouple Extension Wire

ANSI color code—Blue positive/Red negative—Blue Over All

B & S ga.	Wire Type	Insulation Over All	Insulation Each Conductor	Maximum Temp.		Nominal Overall Dimensions (inches)	Part Number
				°F	°C		
20	Solid	Polyvinyl (PVC)	Polyvinyl (PVC)	221	105	.092 × .154	TCW-120-101
20	Stranded (7/28)	Polyvinyl (PVC)	Polyvinyl (PVC)	221	105	.098 × .166	TCW-120-102
20	Solid	PVC/twisted w/ alum. mylar tape shield & bare drain wire	Polyvinyl (PVC)	221	105	.169 round	TCW-120-103

ANSI Type EX Duplex Construction Thermocouple Extension Wire

ANSI color code—Purple positive/Red negative—Purple Over All

B & S ga.	Wire Type	Insulation Over All	Insulation Each Conductor	Maximum Temp.		Nominal Overall Dimensions (inches)	Part Number
				°F	°C		
20	Solid	Polyvinyl (PVC)	Polyvinyl (PVC)	221	105	.092 × .154	TCW-122-101
20	Solid	PVC/twisted w/ alum. Mylar tape shield & bare drain wire	Polyvinyl (PVC)	221	105	.169 round	TCW-122-102

ANSI Type R/SX Copper/#11 Alloy Duplex Construction Insulated Extension Wire

ANSI color code—Black positive/Red negative—Green Over All (Compensating alloys for Type “S” and Type “R” thermocouples)

B & S ga.	Wire Type	Insulation Over All	Insulation Each Conductor	Maximum Temp.		Nominal Overall Dimensions (inches)	Part Number
				°F	°C		
20	Solid	PVC/twisted w/ alum. Mylar tape shield & bare drain wire	Polyvinyl (PVC)	221	105	.169 round	TCW-123-101
20	Solid	Polyvinyl (PVC)	Polyvinyl (PVC)	221	105	.092 × .154	TCW-123-102
20	Solid	Extruded (FEP) Teflon®	Extruded (FEP) Teflon®	400	204	.068 × .116	TCW-123-103
20	Solid	Glass Braid	Glass Braid	900	482	.060 × .106	TCW-123-104

Ordering Information

Order by **Part Number** for wire stocked on standard 100 and 250 foot spools.
Order by **Part Number** and **Length** in feet required (50 feet minimum) for wire not stocked on standard spools.

⚠ WARNING: Cancer and Reproductive Harm - www.P65Warnings.ca.gov.

Coil Cord for Thermocouples and RTDs

Design/Special Features

- * Complements modern instrumentation.
- * Designed to be space saving and convenient with excellent retractability.
- * Rated for 221°F (105°C) upper limit (above 104°F [40°C], coil form may change if stretched).
- * ANSI Color Coded Outer Jacket.
- * Wire is 26 gauge stranded with PVC insulation and the outer jacket is polyurethane.
- * Available with mini plug molded on one end only for thermocouples and has open ends only for 3-wire RTDs.
- * Can be used with all available thermocouple or RTD plugs, jacks and cable clamps, standard or miniature.
- * Open ends have approximately 4 inches straight.



Calibration	Outer Jacket Color	Coil Length (in)	Extended Length Maximum (in)	Part Number	
				† With Miniature Plug Molded on One End	† Both Ends Open
J	Black	12	60	TCW-124-101	TCW-125-101
J	Black	24	120	TCW-124-102	TCW-125-102
K	Yellow	12	60	TCW-124-103	TCW-125-103
K	Yellow	24	120	TCW-124-104	TCW-125-104
E	Purple	12	60	TCW-124-105	TCW-125-105
T	Blue	12	60	TCW-124-106	TCW-125-106
T	Blue	24	120	TCW-124-107	TCW-125-107
R/S	Green	12	60	TCW-124-108	TCW-125-108
R/S	Green	32	180	—	TCW-125-109
U (2-wire uncompensated)	White	12	60	TCW-124-109	TCW-125-110
3-wire RTD	White	12	60	—	TCW-125-111
3-wire RTD	White	36	180	—	TCW-125-112

† Other configurations and lengths are available on special request. Minimum order may apply. Consult Tempco with your requirements.

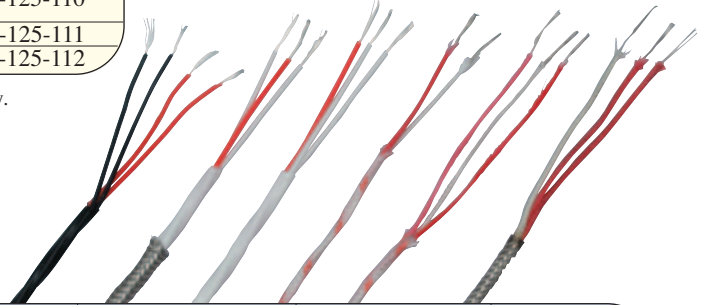

RTD Multiconductor Wire

Part Number	No. of Conductors	B & S Gauge	Inner Insulation	Outer Insulation	Max. Temp. °F	°C	Nom. Overall Size
LDW-126-101	2	24 Str. NPC*	Fiberglass 1xRed, 1xWhite	Fiberglass	900	480	.080"
LDW-120-101	3	24 Str. SPC**	TFE Teflon® 2xWhite, 1xRed	FEP Jacket White w/SS Overbraid	392	200	.140"
LDW-120-102	3	24 Str. SPC**	TFE Teflon® 2xWhite, 1xRed	FEP Jacket, White	392	200	.125"
LDW-120-103	3	24 Str. NPC*	Fiberglass 2xRed, 1xWhite	SS Overbraid	900	480	.115"
LDW-120-104	3	24 Str. NPC*	Fiberglass 2xRed, 1xWhite	Fiberglass	900	480	.086"
LDW-122-101	4	26 Str. SPC**	TFE Teflon® 2xRed, 2xBlack	FEP Jacket, Black	392	200	.125"

* NPC denotes nickel-plated copper

** SPC denotes silver-plated copper

International Color Codes for Thermocouple and Extension Grade Wires

	International IEC 584-3	International IEC 584-3 <i>(Intrinsically Safe)</i>	British BS1843	German DIN43710	Japanese JIS C1610-1981	French NFE-18001
J						
K						
E						
T						
N						
RX						
SX						
BX						



Tempco's Metal Sheathed, Mineral Insulated Thermocouple Cable

Tempco-Pak Thermocouples and cable are manufactured using premium quality materials along with rigid quality control standards to ensure a reliable product that is state of the art. The metal outer sheath protects the thermocouple wires and insulation from contamination and mechanical damage as well as hostile and oxidizing environments while allowing the cable to be moisture proof, formable, weldable, compact and have fast response. The mineral insulation isolates the conductors from the sheath and each other while providing excellent high temperature insulation resistance.

Tempco offers a wide variety of sheath materials to choose from as there is no single sheath material that is suitable for all conditions. The most commonly stocked sheath materials are 304 SS, 316 SS and alloy 600. These are offered in all ANSI recognized thermocouple calibrations.

As a standard, Tempco-Pak Thermocouple cable is made with high purity 94% minimum MgO insulation. Other types and purities are available; however, when selecting a mineral insulation, the environment, temperature rating and cost must be taken into consideration.



Quality Assurance

All Tempco-Pak Thermocouple cable is inspected for appearance, physical and electrical characteristics, as well as conformity to calibration.

Each coil or batch of Tempco-Pak is made from the same production lot of raw materials and processed together. This eliminates the need to calibrate each length cut from the same coil. Samples from each coil are calibrated as shown in the chart.

Tempco-Pak Thermocouple Calibration Temperatures

ANSI Calibration	Standard Calibration Points	Optional Points
T	200°F (93°C), 400°F (204°C)	—
J	200°F (93°C), 500°F (260°C), 1000°F (537°C), 1500°F (815°C)	—
E	300°F (149°C), 500°F (260°C), 1000°F (537°C), 1600°F (871°C)	—
K	300°F (149°C), 500°F (260°C), 1000°F (537°C), 1600°F (871°C), 2000°F (1093°C)*	2200°F (1204°C)*
R	1000°F (537°C), 1600°F (871°C), 2000°F (1093°C)*	2600°F (1426°C)*
S	1000°F (537°C), 1600°F (871°C), 2000°F (1093°C)*	2600°F (1426°C)*
B	1600°F (871°C), 2000°F (1093°C)*, 2600°F (1426°C)*	
N	300°F (149°C), 500°F (260°C), 1000°F (537°C), 1600°F (871°C), 2000°F (1093°C)*	2200°F (1204°C)*

* These calibration points will be checked if the sheath and insulation are rated to this temperature.

Tempco-Pak

Thermocouple Data, Care and Handling

Calibration

Tempco-Pak Thermocouple Cable is normally supplied to ANSI standard limits (tolerances) of error as set forth in ANSI circular MC96.1-1982 and duplicated in ASTM E230. Special limits (tolerances) per ANSI MC96.1 are available at extra cost (See Table 1 on page 14-103).

Annealing

Unless otherwise specified all Tempco-Pak will be furnished in a fully annealed condition.

Formability

Because Tempco-Pak is fully annealed it can normally be formed around a mandrel 4 times the sheath diameter without loss of insulation resistance or the sheath's integrity.

Weldability

Tempco-Pak can be brazed, soldered or welded upon its sheath. However, because of the delicate nature of the fabricating of hot junctions, it is recommended they be done at the factory. Brazing or soldering material should not come in contact with the mineral insulation as the flux or resin will contaminate the insulation.

Insulation Resistance

Tempco-Pak should have a minimum insulation resistance wire to wire and wire to sheath at room temperature of 100 megohms at 50 VDC for 0.093" O.D. and smaller and 100 megohms at 100 VDC for .100" O.D. and larger.

Shipping and Packaging

Tempco-Pak is stocked in random lengths with the maximum stock lengths listed in the tables showing the varieties of commonly available material. Tempco reserves the right to supply random lengths of our choice unless specific lengths are specified on your order. Tempco-Pak can be furnished in coil form or in straight lengths. Normally .375" diameter and .312" diameter are shipped in straight lengths. Longer lengths are available on special order.

Handling and Storage

To prevent moisture from being absorbed by the hygroscopic insulation, both ends of the lengths of Tempco-Pak are sealed at the factory with a suitable sealer. Under some conditions, moisture absorption could take place that would lower the insulation resistance and may prove to be troublesome in subsequent assembly and welding, so it is advisable to store Tempco-Pak in a dry place. Slight moisture penetration can be remedied by removing approximately 3 inches from each end. Apply heat (approx. 300°F) 6 to 7 inches from the open end and slowly work heat toward and over the open end. Allow end to cool to approximately 180°F and reseal end. When pieces are cut from stock lengths, the exposed ends should be squared and resealed immediately to prevent contamination or moisture absorption. For deeper moisture penetration, bake entire length of material with both ends open for 24 hours at 250°F to 300°F to remove moisture and bring up insulation resistance. If baking does not bring the insulation resistance to acceptable levels, discard the material. As an option Tempco can provide Tempco-Pak with the ends seal welded.



Selecting the Mineral Insulated Thermocouple Cable Suited to Your Requirement

Tempco offers a wide variety of sheathed, mineral insulated thermocouple cable. We stock many varieties of sheath diameters and materials in ANSI recognized thermocouple types and can manufacture a multitude of non-stock combinations of sheath materials, O.D.s, insulations, wire types and wire configurations on special request. Consult Tempco with your specific requirements.

When selecting a cable for an application there are four things that must be considered:

Sheath Material

The outer sheath protects the insulation and wires from physical damage, contamination and the environment, all of which affect the service life and cost. As there isn't any one particular sheath material that is appropriate for all conditions, Tempco offers you a choice.

Wire Types (Calibration)

Selecting the proper conductors can be crucial to the function the MI cable is to perform. Where thermocouple cable is concerned, selecting the appropriate calibration for the temperature to be measured, the instrumentation available, and the environment will be a significant factor in the accuracy, life and cost.

Insulation Material

The insulation material isolates the wires from each other and the sheath. Because the wires are used as conductors, the insulating material becomes important in preventing electrical shorts and dielectric breakdown, particularly at elevated temperatures.

Physical Parameters

The four main physical characteristics of the MI cable that should be taken into account are:

- a. Sheath Diameter
- b. Sheath Wall Thickness
- c. Conductor Size
- d. Conductor Location (4 and 6 wires)

These will directly affect service life, flexibility, time response, weldability, strength and cost.

The following pages will serve as a guide for sheath materials, insulation materials and the various ANSI thermocouple calibrations.



The following information is designed to be used as a guide and may not be correct in every application. If in doubt, consult with your Tempco sales engineer or the factory. Temperatures shown are maximum recommended operating temperatures.

Sheath Material

NOTE: Letters in parentheses following the sheath material are used with the Ordering Worksheet on page 14-119.

Alloy 600 (A)

Maximum temperature: 1177°C (2150°F). Most widely used thermocouple sheath material. Good high temperature strength, corrosion resistance, resistance to chloride-ion stress corrosion cracking and oxidation resistance to high temperatures. Do not use in sulfur-bearing environments. Good in nitriding environments.

304 SS (B)

Maximum temperature: 900°C (1650°F). Most widely used low temperature sheath material. Extensively used in food, beverage, chemical and other industries where corrosion resistance is required. Subject to damaging carbide precipitation in 482° to 871°C (900° to 1600°F) range. Lowest-cost corrosion resistant sheath material available.

316 SS (C)

Maximum temperature: 900°C (1650°F). Best corrosion resistance of the austenitic stainless steel grades. Good corrosion resistance in H₂S. Widely used in the food and chemical industry. Subject to damaging carbide precipitation in 482° to 871°C (900° to 1600°F) range.

304L (D)

Maximum temperature: 900°C (1650°F). Low-carbon version of 304 SS (B). Low carbon content allows this material to be welded and heated in the 482° to 871°C (900° to 1600°F) range without damage to corrosion resistance.

316L (E)

Maximum temperature: 900°C (1650°F). Same as 316 SS (C) except low-carbon version allows for better welding and fabrication.

CONTINUED

Sheath Material (continued)

NOTE: Letters in parentheses following the sheath material are used with the Ordering Worksheet on page 14-119.

310 SS (F)

Maximum temperature: 1150°C (2100°F). Mechanical and corrosion resistance, similar to but better than 304 SS. Very good heat resistance. This alloy contains 25% Cr, 20% Ni. Not as ductile as 304 SS.

321 SS (G)

Maximum temperature: 871°C (1600°F). Similar to 304 SS except titanium stabilized for intergranular corrosion. This alloy is designed to overcome susceptibility to carbide precipitation in the 482°C to 871°C (900°F to 1600°F) range. Used in aerospace and chemical applications.

347 SS (H)

Maximum temperature: 871°C (1600°F). Similar to 304 SS except nickel columbium stabilized. This alloy is designed to overcome susceptibility to carbide precipitation in the 482°C to 871°C (900°F to 1600°F) range. Used in aerospace and chemical applications.

446 SS (L)

Maximum temperature: 1150°C (2100°F). Ferritic stainless steel, which has good resistance to sulfurous atmospheres at high temperatures. Good corrosion resistance to nitric acid, sulfuric acid and most alkalis. 27% chromium content gives this alloy the highest heat resistance of any ferritic stainless steel.

Hastelloy X® (Q)

Maximum temperature: 1204°C (2200°F). Widely used in aerospace applications. Resistant to oxidizing, reducing and neutral atmospheric conditions. Excellent high temperature strength along with superior oxidation resistance. Resistant to stress corrosion cracking in petrochemical applications.

Incoloy® 800 (S)

Maximum temperature: 1093°C (2000°F). Widely used as heater sheath material. Minimal use in thermocouples. Superior to Alloy 600 in sulfur, cyanide salts and fused neutral salts. Susceptible to intergranular attack in some applications by exposure to the temperature range of 538°C to 760°C (1000° to 1400°F).

Incoloy® 800HT (T)

Maximum temperature: 1093°C (2000°F). Same as Incoloy 800® (S) except carbon content is limited to upper end of range. This provides significantly higher creep and rupture strength. Used in the chemical and petrochemical industry for long-term exposure to high temperatures.

Inconel® 601 (R)

Maximum temperature: 1177°C (2150°F) Continuous; 1260°C (2300°F) Intermittent. Similar to Alloy 600 with the addition of aluminum for outstanding oxidation resistance. Designed for high temperature corrosion resistance. This material is good in carburizing environments, and has good creep rupture strength. Do not use in vacuum furnaces! Susceptible to intergranular attack by prolonged heating in 538°C to 760°C (1000°F to 1400°F) temperature range.

Molybdenum (V)

Maximum temperature in air: 399°C (750°F). Melting point: 2610°C (4730°F). Refractory metal. Brittle; cannot be bent. Use only in inert, vacuum or reducing atmospheres. Most commonly used with BeO insulation and Tungsten Rhenium conductors. Uncompacted assemblies only.

Nickel 200 (J)

Maximum temperature: 315°C (600°F). Commercially pure wrought Nickel with good resistance to a wide range of corrosive materials. For temperatures above 600°F use Nickel 201 to prevent embrittlement by intergranular corrosion.

Nickel 201 (K)

Maximum temperature: 1093°C (2000°F). Commercially pure wrought nickel with low carbon. Used in molten salt bath furnaces. Offers good resistance to caustic alkalines and fluorine.

Platinum 10% Rhodium (N)

Maximum temperature: 1552°C (2825°F). Excellent oxidation resistance. Same type of uses as platinum 20% rhodium except lower cost and reduced operating range.

Platinum 20% Rhodium (P)

Maximum temperature: 1649°C (3000°F). Excellent oxidation resistance. Very expensive oxidation resistant alloy used in glass manufacturing and in research applications. Also used for gas turbine test thermocouples.

Pure Platinum (M)

Maximum temperature: 1482°C (2700°F). Platinum is the only metallic material capable of operating in an oxidizing atmosphere above 1260°C (2300°F) for extended periods of time. Normally used with type R, S or B conductors. Used in glass manufacturing, high temperature furnaces and as control standards.

Tantalum (U)

Maximum temperature in air: 482°C (900°F). Melting point: 2996°C (5425°F). Refractory metal. Very ductile. Use only in inert or very good vacuums—10-3 torr or better. Most commonly used with BeO and Tungsten Rhenium conductors. Do not use in environments containing nitrogen above 371°C (700°F).



Mineral Insulated Cable Calibration

NOTE: Letters in parentheses following the sheath material are used with the Ordering Worksheet on page 14-119.

ANSI Type (J) Standard; Special Tolerance (3)

Type J is composed of a positive leg (JP) which is iron and a negative leg (JN) which is approximately 45% nickel, 55% copper. When protected by the compacted mineral insulation and appropriate outer sheath, Type J is usable from 32°F to 1500°F. Type J is not susceptible to short range ordering in the 700 to 1000°F temperature range (+2°F to +4°F drift), which occurs with ANSI Type E and K. This low-cost, stable thermocouple calibration is primarily used with 94% minimum purity MgO insulation and a stainless steel sheath.

ANSI Type (K) Standard; Special Tolerance (4)

Type K is composed of a positive leg (KP) which is approximately 90% nickel, 10% chromium and a negative leg (KN) which is approximately 95% nickel, 2% aluminum, 2% manganese and 1% silicon. When protected by the compacted mineral insulation and appropriate outer sheath, Type K is usable from 32°F to 2300°F and is one of Tempco's most popular calibration types. If the application temperature is between 600°F and 1100°F, we recommend using Type J or Type N because of short range ordering that can cause drift of +2°F to +4°F in a few hours' time. Type K is relatively stable to radiation transmutation and is used in nuclear environments. For applications below 32°F, special alloy selections are usually required.

ANSI Type (E) Standard; Special Tolerance (5)

Type E is composed of a positive leg (EP) which is approximately 90% nickel, 10% chromium and a negative leg (EN) which is approximately 45% nickel, 55% copper. When protected by the compacted mineral insulation and appropriate outer sheath, Type E is usable from 32°F to 1650°F. This thermocouple has the highest EMF output per degree of all ANSI recognized thermocouples. If the application temperature is between 600°F and 1100°F, we recommend using Type J or Type N because of short range ordering that can cause drift of +2°F to +4°F in a few hours' time. For applications below 32°F, special alloy selections may be required.

ANSI Type (T) Standard; Special Tolerance (6)

Type T is composed of a positive leg (TP) which is pure copper and a negative leg (TN) which is approximately 45% nickel, 55% copper. When protected by the compacted mineral insulation and appropriate outer sheath, Type T is usable from 32°F to 662°F. Type T is very stable and is used in a wide variety of cryogenic and low temperature applications. For applications below 32°F special alloy selections may be required.

ANSI Type (N) Standard; Special Tolerance (7)

Type N is composed of a positive leg (Nicrosil) which is approximately 14% chromium, 1.4% silicon, 84.6% nickel and a negative leg (Nisil) which is approximately 4.4% silicon, 95.6% nickel. When protected by compacted mineral insulation and appropriate outer sheath, Type N is usable from 32°F to 2300°F. Type N was designed to overcome several problems inherent in Type K thermocouples. Short range ordering (+2°F to +4°F drift) in the 600°F to 1100°F temperature range is greatly reduced, and the drift rate at high temperatures is considerably less. Type N has also been found to be more stable than Type K in nuclear environments.

ANSI Type (R) Standard Tolerance

Type R is composed of a positive leg (RP), which is 87% platinum, 13% rhodium and a negative leg (RN), which is 100% platinum. When protected by compacted mineral insulation and appropriate outer sheath, Type R is usable from 32°F to 2700°F. Type R is available as standard limits only, ITS90.

ANSI Type (S) Standard Tolerance

Type S is composed of a positive leg (SP), which is 90% platinum, 10% rhodium and a negative leg (SN), which is 100% platinum. When protected by compacted mineral insulation and appropriate outer sheath, Type S is usable from 32°F to 2700°F. Type S has a lower EMF output than Type R and is available as standard limits only, ITS90.

ANSI Type (B) Standard Tolerance

Type B is composed of a positive leg (BP) which is approximately 70% platinum, 30% rhodium and a negative leg (BN) which is approximately 94% platinum, 6% rhodium. When protected by compacted mineral insulation and appropriate outer sheath, Type B is usable from 1600°F to 3100°F. Type B is available as standard limits only, IPTS 1968 scale.

Tungsten—5% Re/Tungsten, 26% Re (C)

This calibration has not been given a letter designation by ANSI. When this calibration is protected by mineral insulation and appropriate outer sheath, it is usable from 32°F to 4200°F. Calibration is used most often with Beryllium Oxide insulation and either molybdenum or tantalum sheath. These combinations can only be used in an inert or vacuum environment.

Miscellaneous (O)

Consult Tempco with your requirements.

Mineral Insulated Thermocouple Cable

Insulation

NOTE: Letters in parentheses following the sheath material are used with the Ordering Worksheet on page 14-119.

Magnesium Oxide — MgO 96% Typical (M)

This insulation is widely used in thermocouple and heater applications below 2000°F. SiO₂ is the major impurity that provides excellent insulation resistance. Do not use with platinum or in nuclear application.

High Purity Magnesium Oxide — MgO 99.4% Minimum Purity (H)

Low impurity levels make this insulation very useful for all thermocouple calibrations up to 2500°F. Above 2500°F we recommend using Hafnia Oxide (HfO₂) insulation because of MgO's low resistivity. This material meets the requirements established in ASTM E-235-82.

Alumina Oxide — Al₂O₃ 99.6% Minimum Purity (A)

Although this material is comparable to MgO in its electrical properties and cost, it does not compact as well and tends to "powder out." This undesirable characteristic has made this insulation unpopular in industry so cable with this type of insulation is available only as a "special."

Complete Your Thermal Loop System

Instrumentation

Videographic Data Loggers and Paper Chart Recorders

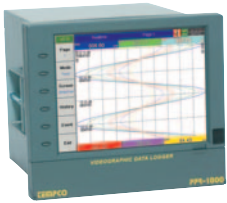

Complete details can be found
in Section 12 of this catalog.



TEC Temperature Controllers



Complete details can be found
in Section 13 of this catalog.





Mineral Insulated Thermocouple Cable Ordering Worksheet

Ordering Code: **MTC** -

Designates
TEMPCO-PAK Sheathed
Mineral Insulated
Thermocouple Cable

Calibration Code — See page 14-117

ANSI Standard Tolerances	Special Tolerances
J = (Iron/Constantan)	3
K = (Chromel®/Alumel)	4
E = (Chromel®/Constantan)	5
T = (Cu/Constantan)	6
N = (Nicrosil®/Nisil)	7
R = (Pt/Pt-13% Rh) PER ITS-90	
S = (Pt/Pt-10% Rh) PER ITS-90	
B = (Plat-6% Rh/Plat-30% Rh)	
C = (W-5% Re/W-26% Re)	
O = Miscellaneous (Consult Factory)	

Number of Conductors

- 2** = 2-wire construction (Single Element)
- 4** = 4-wire construction (Duplex Element)

Insulation — See page 14-118

- M** = 96% min. MgO
- H** = 99.4% min. MgO
- A** = 99.6% Alumina

Ordering Worksheet



Note: For a complete description of Worksheet options see pages 14-115 through 14-118.

Sheath O.D.

A = .020" ±.001	L = 1.0 mm ±.03
B = .032" ±.001	N = 1.5 mm ±.03
C = .040" ±.001	P = 2.0 mm ±.03
D = .063" ±.001	Q = 3.0 mm ±.05
E = .093" ±.002	R = 4.5 mm ±.05
F = .125" ±.002	S = 6.0 mm +.07/-.05
G = .188" ±.002	T = 8.0 mm +.07/-.05
H = .250" +.003/-.002	V = 9.0 mm +.07/-.05
J = .313" +.003/-.002	
K = .375" +.003/-.002	

Sheath Material — See pages 14-115 and 14-116

A = Alloy 600	L = 446 SS
B = 304 SS	M = Pure platinum
C = 316 SS	N = Platinum 10% rhodium
D = 304L SS	P = Platinum 20% rhodium
E = 316L SS	Q = Hastelloy X®
F = 310 SS	R = Inconel® 601
G = 321 SS	S = Incoloy® 800
H = 347 SS	T = Incoloy® 800HT
J = Nickel 200	U = Tantalum
K = Nickel 201	V = Molybdenum

WARNING: Cancer and Reproductive Harm - www.P65Warnings.ca.gov.



Single Element Standard Size List



O.D. (in.)	Part Number	ANSI Calibration	Insulation (Min. Purity)	Sheath Material	Nom. Wall Thickness (in.)	Nom. B&S Wire ga.	Max. Operating Temp. (°F)	Max. Stock Length (ft.)
.020 ±.001	MTC00001	J	99.4% MgO	Alloy 600	.003	39	1500	50
	MTC00002	K	99.4% MgO	Alloy 600	.003	39	1650	50
	MTC00003	J	99.4% MgO	304	.003	39	1500	50
	MTC00004	K	99.4% MgO	304	.003	39	1650	50
.032 ±.001	MTC00005	J	99.4% MgO	Alloy 600	.005	36	1500	150
	MTC00006	K	99.4% MgO	Alloy 600	.005	36	1800	150
	MTC00007	J	99.4% MgO	304	.005	36	1500	150
	MTC00008	K	99.4% MgO	304	.005	36	1650	150
.040 ±.001	MTC00009	J	99.4% MgO	Alloy 600	.006	33	1500	175
	MTC00010	K	99.4% MgO	Alloy 600	.006	33	2000	175
	MTC00011	J	99.4% MgO	304	.006	33	1500	175
	MTC00012	K	99.4% MgO	304	.006	33	1650	175
	MTC00013	E	99.4% MgO	304	.006	33	1600	175
	MTC00014	T	99.4% MgO	304	.006	33	650	175
	MTC00015	J	99.4% MgO	316	.006	33	1500	175
	MTC00016	K	99.4% MgO	316	.006	33	1650	175
.062 ±.001	MTC00017	J	96.0% MgO	Alloy 600	.008	30	1500	500
	MTC00018	J	99.4% MgO	Alloy 600	.008	30	1500	500
	MTC00019	K	96.0% MgO	Alloy 600	.008	30	2000	500
	MTC00020	K	99.4% MgO	Alloy 600	.008	30	2000	500
	MTC00021	J	96.0% MgO	304	.008	30	1500	500
	MTC00022	J	99.4% MgO	304	.008	30	1500	500
	MTC00023	K	96.0% MgO	304	.008	30	1650	500
	MTC00024	K	99.4% MgO	304	.008	30	1650	500
	MTC00025	E	96.0% MgO	304	.008	30	1600	500
	MTC00026	T	99.4% MgO	304	.008	30	650	500
	MTC00027	J	96.0% MgO	316	.008	30	1500	500
	MTC00028	J	99.4% MgO	316	.008	30	1500	500
	MTC00029	K	96.0% MgO	316	.008	30	1650	500
	MTC00030	K	99.4% MgO	316	.008	30	1650	500
.093 ±.002	MTC00031	J	96.0% MgO	Alloy 600	.010	27	1500	450
	MTC00032	J	99.4% MgO	Alloy 600	.010	27	1500	450
	MTC00033	K	96.0% MgO	Alloy 600	.010	27	2000	450
	MTC00034	K	99.4% MgO	Alloy 600	.010	27	2150	450
	MTC00035	J	96.0% MgO	304	.010	27	1500	450
	MTC00036	J	99.4% MgO	304	.010	27	1500	450
	MTC00037	K	96.0% MgO	304	.010	27	1650	450
	MTC00038	K	99.4% MgO	304	.010	27	1650	450
.125 ±.002	MTC00039	J	96.0% MgO	Alloy 600	.014	24	1500	250
	MTC00040	J	99.4% MgO	Alloy 600	.014	24	1500	250
	MTC00041	K	96.0% MgO	Alloy 600	.014	24	2000	250
	MTC00042	K	99.4% MgO	Alloy 600	.014	24	2150	250
	MTC00043	J	96.0% MgO	304	.014	24	1500	250
	MTC00044	J	99.4% MgO	304	.014	24	1500	250
	MTC00045	K	96.0% MgO	304	.014	24	1650	250
	MTC00046	K	99.4% MgO	304	.014	24	1650	250
	MTC00047	E	96.0% MgO	304	.014	24	1600	250
	MTC00048	T	96.0% MgO	304	.014	24	650	250
	MTC00049	J	96.0% MgO	316	.014	24	1500	250
	MTC00050	J	99.4% MgO	316	.014	24	1500	250
	MTC00051	K	96.0% MgO	316	.014	24	1650	250
	MTC00052	K	99.4% MgO	316	.014	24	1650	250
	MTC00053	E	96.0% MgO	316	.014	24	1600	250
	MTC00054	T	96.0% MgO	316	.014	24	650	250
	MTC00055	J	96.0% MgO	310	.014	24	1500	250
	MTC00056	K	96.0% MgO	310	.014	24	2000	250
MTC00057	R	99.4% MgO	Alloy 600	.020	24	2150	250	
MTC00058	S	99.4% MgO	Alloy 600	.020	24	2150	250	

CONTINUED



Single Element Standard Size List



Continued from previous page...

O.D. (in.)	Part Number	ANSI Calibration	Insulation (Min. Purity)	Sheath Material	Nom. Wall Thickness (in.)	Nom. B&S Wire ga.	Max. Operating Temp. (°F)	Max. Stock Length (ft.)
.188 ±.002	MTC00059	J	96.0% MgO	Alloy 600	.022	21	1500	120
	MTC00060	J	99.4% MgO	Alloy 600	.022	21	1500	120
	MTC00061	K	96.0% MgO	Alloy 600	.022	21	2000	120
	MTC00062	K	99.4% MgO	Alloy 600	.022	21	2150	120
	MTC00063	J	96.0% MgO	304	.022	21	1500	120
	MTC00064	J	99.4% MgO	304	.022	21	1500	120
	MTC00065	K	96.0% MgO	304	.022	21	1650	120
	MTC00066	K	99.4% MgO	304	.022	21	1650	120
	MTC00067	E	96.0% MgO	304	.022	21	1600	120
	MTC00068	T	96.0% MgO	304	.022	21	650	120
	MTC00069	J	96.0% MgO	316	.022	21	1500	120
	MTC00070	J	99.4% MgO	316	.022	21	1500	120
	MTC00071	K	96.0% MgO	316	.022	21	1650	120
	MTC00072	K	99.4% MgO	316	.022	21	1650	120
	MTC00073	E	96.0% MgO	316	.022	21	1600	120
	MTC00074	T	96.0% MgO	316	.022	21	650	120
	MTC00075	J	96.0% MgO	310	.022	21	1500	120
	MTC00076	K	96.0% MgO	310	.022	21	2000	120
.250 +.003 -.002	MTC00077	J	96.0% MgO	Alloy 600	.029	18	1500	70
	MTC00078	J	99.4% MgO	Alloy 600	.029	18	1500	70
	MTC00079	K	96.0% MgO	Alloy 600	.029	18	2000	70
	MTC00080	K	99.4% MgO	Alloy 600	.029	18	2150	70
	MTC00081	J	96.0% MgO	304	.029	18	1500	70
	MTC00082	J	99.4% MgO	304	.029	18	1500	70
	MTC00083	K	96.0% MgO	304	.029	18	1650	70
	MTC00084	K	99.4% MgO	304	.029	18	1650	70
	MTC00085	E	96.0% MgO	304	.029	18	1600	70
	MTC00086	T	96.0% MgO	304	.029	18	650	70
	MTC00087	J	96.0% MgO	316	.029	18	1500	70
	MTC00088	J	99.4% MgO	316	.029	18	1500	70
	MTC00089	K	96.0% MgO	316	.029	18	1650	70
	MTC00090	K	99.4% MgO	316	.029	18	1650	70
	MTC00091	E	96.0% MgO	316	.029	18	1600	70
	MTC00092	T	96.0% MgO	316	.029	18	650	70
MTC00093	J	96.0% MgO	310	.029	18	1500	70	
MTC00094	K	96.0% MgO	310	.029	18	2000	70	
.313 +.003 -.002	MTC00095	J	96.0% MgO	Alloy 600	.036	17	1500	40
	MTC00096	J	96.0% MgO	304	.036	17	1500	40
	MTC00097	K	96.0% MgO	Alloy 600	.036	17	2000	40
	MTC00098	K	96.0% MgO	304	.036	17	1650	40
	MTC00099	E	96.0% MgO	304	.036	17	1600	40
	MTC00100	E	96.0% MgO	316	.036	17	1600	40
	MTC00101	J	96.0% MgO	316	.036	17	1500	40
	MTC00102	K	96.0% MgO	316	.036	17	1650	40
.375 +.003 -.002	MTC00103	J	96.0% MgO	Alloy 600	.045	15	1500	30
	MTC00104	J	96.0% MgO	304	.045	15	1500	30
	MTC00105	K	96.0% MgO	Alloy 600	.045	15	2000	30
	MTC00106	K	96.0% MgO	304	.045	15	1650	30
	MTC00107	J	96.0% MgO	316	.045	15	1500	30
	MTC00108	K	96.0% MgO	316	.045	15	1650	30



Duplex Element — Diagonal Standard Size List



O.D. (in.)	Part Number	ANSI Calibration	Insulation (Min. Purity)	Sheath Material	Nom. Wall Thickness (in.)	Nom. B&S Wire Ga.	Max. Operating Temp. (°F)	Max. Stock Length (ft.)
.063 ±.001	MTC00109	J	99.4% MgO	Alloy 600	.009	30	1500	500
	MTC00110	K	99.4% MgO	Alloy 600	.009	30	2000	500
	MTC00111	J	99.4% MgO	304	.009	30	1500	500
	MTC00112	K	99.4% MgO	304	.009	30	1650	500
.125 ±.002	MTC00113	J	96.0% MgO	Alloy 600	.016	24	1500	250
	MTC00114	K	96.0% MgO	Alloy 600	.016	24	2000	250
	MTC00115	J	96.0% MgO	304	.016	24	1500	250
	MTC00116	K	96.0% MgO	304	.016	24	1650	250
	MTC00117	E	96.0% MgO	304	.016	24	1600	250
	MTC00118	J	96.0% MgO	316	.016	24	1500	250
	MTC00119	K	96.0% MgO	316	.016	24	1650	250
.188 ±.002	MTC00120	J	96.0% MgO	Alloy 600	.024	21	1500	120
	MTC00121	K	96.0% MgO	Alloy 600	.024	21	2000	120
	MTC00122	J	96.0% MgO	304	.024	21	1500	120
	MTC00123	K	96.0% MgO	304	.024	21	1650	120
	MTC00124	E	96.0% MgO	304	.024	21	1600	120
	MTC00125	T	96.0% MgO	304	.024	21	650	120
	MTC00126	J	96.0% MgO	316	.024	21	1500	120
	MTC00127	K	96.0% MgO	316	.024	21	1650	120
.250 +.003 -.002	MTC00128	J	96.0% MgO	Alloy 600	.031	19	1500	70
	MTC00129	K	96.0% MgO	Alloy 600	.031	19	2000	70
	MTC00130	J	96.0% MgO	304	.031	19	1500	70
	MTC00131	K	96.0% MgO	304	.031	19	1650	70
	MTC00132	E	96.0% MgO	304	.031	19	1600	70
	MTC00133	T	96.0% MgO	304	.031	19	650	70
	MTC00134	J	96.0% MgO	316	.031	19	1500	70
	MTC00135	K	96.0% MgO	316	.031	19	1650	70
.313 +.003 -.002	MTC00136	J	96.0% MgO	Alloy 600	.039	17	1500	40
	MTC00137	K	96.0% MgO	Alloy 600	.039	17	2000	40
	MTC00138	J	96.0% MgO	304	.039	17	1500	40
	MTC00139	K	96.0% MgO	304	.039	17	1650	40
	MTC00140	E	96.0% MgO	304	.039	17	1600	40
	MTC00141	T	96.0% MgO	304	.039	17	650	40
.375 +.003 -.002	MTC00142	J	96.0% MgO	Alloy 600	.047	15	1500	30
	MTC00143	K	96.0% MgO	Alloy 600	.047	15	2000	30
	MTC00144	J	96.0% MgO	304	.047	15	1500	30
	MTC00145	K	96.0% MgO	304	.047	15	1650	30
	MTC00146	E	96.0% MgO	304	.047	15	1600	30
	MTC00147	T	96.0% MgO	304	.047	15	650	30



Metric — Single Element Standard Size List



O.D. (mm.)	Part Number	ANSI Calibration	Insulation (Min. Purity)	Sheath Material	Nom. Wall Thickness (mm.)	Nom. Wire Dia. (mm)	Max. Operating Temp. (°C)	Max. Stock Length (m.)
1.5 ±.03	MTC00148	J	99.4% MgO	Alloy 600	0.20	0.28	815	167
	MTC00149	K	99.4% MgO	Alloy 600	0.20	0.28	1093	167
	MTC00150	J	99.4% MgO	304	0.20	0.28	815	167
	MTC00151	K	99.4% MgO	304	0.20	0.28	898	167
2.0 ±.03	MTC00152	J	96.0% MgO	Alloy 600	0.25	0.36	815	93
	MTC00153	K	96.0% MgO	Alloy 600	0.25	0.36	1093	93
	MTC00154	J	96.0% MgO	304	0.25	0.36	815	93
	MTC00155	K	96.0% MgO	304	0.25	0.36	898	93
	MTC00156	J	96.0% MgO	316	0.25	0.36	815	93
	MTC00157	K	96.0% MgO	316	0.25	0.36	898	93
3.0 ±.05	MTC00158	J	96.0% MgO	Alloy 600	0.33	0.46	815	84
	MTC00159	K	96.0% MgO	Alloy 600	0.33	0.46	1093	84
	MTC00160	J	96.0% MgO	304	0.33	0.46	815	84
	MTC00161	K	96.0% MgO	304	0.33	0.46	898	84
	MTC00162	E	96.0% MgO	304	0.33	0.46	871	84
	MTC00163	T	96.0% MgO	304	0.33	0.46	343	84
	MTC00164	J	96.0% MgO	316	0.33	0.46	815	84
	MTC00165	K	96.0% MgO	316	0.33	0.46	898	84
4.5 ±.05	MTC00166	J	96.0% MgO	Alloy 600	0.53	0.69	815	37
	MTC00167	K	96.0% MgO	Alloy 600	0.53	0.69	1093	37
	MTC00168	J	96.0% MgO	304	0.53	0.69	815	37
	MTC00169	K	96.0% MgO	304	0.53	0.69	898	37
6.0 +07 -05	MTC00170	J	96.0% MgO	Alloy 600	0.69	0.94	815	21
	MTC00171	K	96.0% MgO	Alloy 600	0.69	0.94	1093	21
	MTC00172	J	96.0% MgO	304	0.69	0.94	815	21
	MTC00173	K	96.0% MgO	304	0.69	0.94	898	21
8.0 +07 -05	MTC00174	J	96.0% MgO	Alloy 600	0.91	1.22	815	12
	MTC00175	K	96.0% MgO	Alloy 600	0.91	1.22	1093	12
	MTC00176	J	96.0% MgO	304	0.91	1.22	815	12
	MTC00177	K	96.0% MgO	304	0.91	1.22	898	12

Ordering Information

Standard Thermocouple Cable

Order by Part Number from the Lists on Pages 14-120 through 14-123.

Thermocouple wire is sold by the foot and is subject to minimum billing.

Tempco-Pak is stocked in random lengths with the maximum stock lengths listed in the tables showing the varieties of commonly available material. Tempco reserves the right to supply random lengths of our choice unless specific lengths are indicated on your order. Tempco-Pak can be furnished in coil form or in straight lengths. Normally .375" diameter and .312" diameter are shipped in straight lengths. Longer lengths are available on special order.

Custom Manufactured Thermocouple Cables

For sizes and specifications not listed, Tempco will design and manufacture a Mineral Insulated Thermocouple Cable to meet your requirements. Please refer to the ordering worksheet on page 14-119 and follow the model as diagrammed to specify your requirements with the Tempco code number.

In addition, refer to page 14-124 and **specify the following:**

- Configuration type
- Sheath wall thickness
- Conductor Configuration and Size
- Minimum acceptable lengths and total length required

⚠ WARNING: Cancer and Reproductive Harm - www.P65Warnings.ca.gov.

(800) 323-6859 • Email: sales@tempco.com

Made-To-Order Mineral-Insulated Cable

In addition to the standard line of Tempco-Pak Thermocouple Cables, we can also manufacture metal sheathed, mineral insulated cable in special configurations using a wide variety of sheath materials and conductor alloys such as copper, nickel, alloy 600, CHROMEL-A®, nickel clad copper, 304 SS and virtually any other malleable metal.

Properly selected combinations of materials (sheath, insulation and wire) will exhibit the same outstanding qualities and performance as our standard Tempco-Pak.

Shown below are standard and special Tempco-Pak configurations. *Consult Tempco with your specific requirements.*

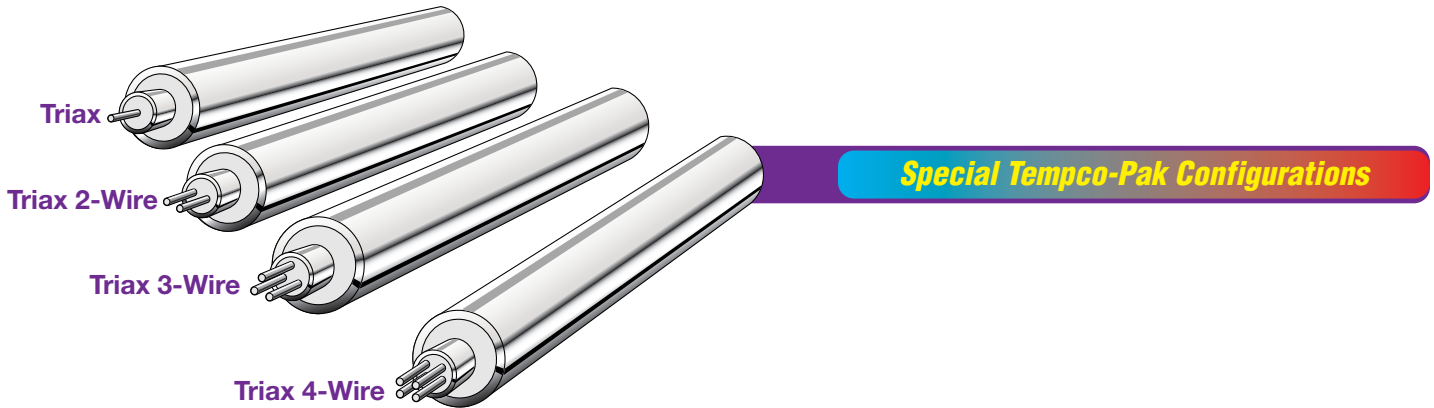
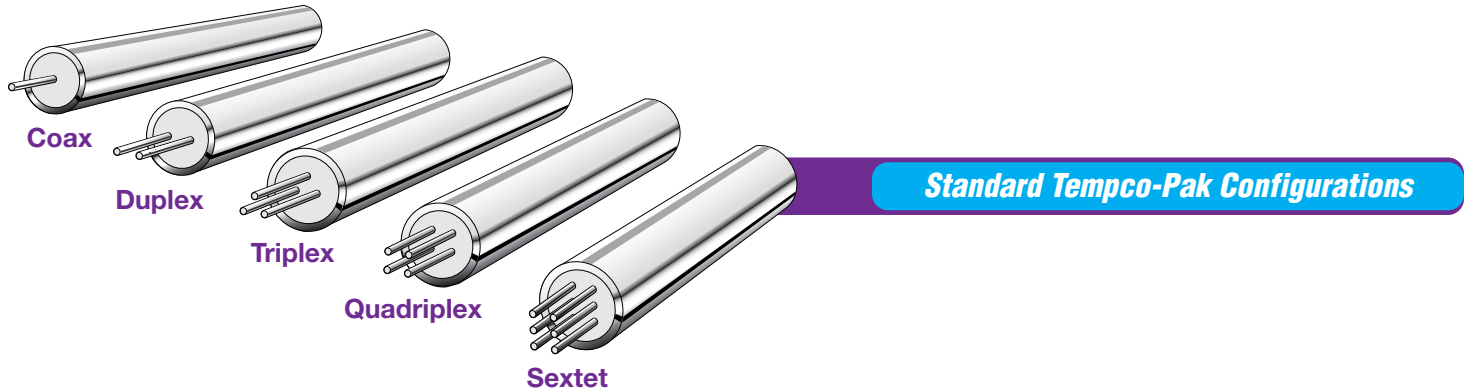

Ordering Information

Made-To-Order Mineral-Insulated Cable

Custom Manufactured Mineral-Insulated Cable

Supply the following information when requesting a quotation on made-to-order mineral-insulated cable:

- Configuration type
- Sheath material
- Insulation type and purity
- Calibration type or conductor material
- Conductor configuration and size
- Sheath wall thickness
- Minimum acceptable lengths and total length required

⚠ WARNING: Cancer and Reproductive Harm - www.P65Warnings.ca.gov.

Glossary of Temperature Sensing Terms

Absolute Zero — Theoretically, the lowest possible temperature. A body at absolute zero would have no molecular motion or heat energy. It is the zero point on the Kelvin and Rankine scales, and is estimated to be -273.15°C or -459.67°F .

Accuracy — A statement that is used to define the largest allowable error in a device or system. It is an indication of how close measured values are to true values. It can be expressed in both measured units and in percentages.

Alloy #11 — A Harrison Alloys trademark for a low-cost negative thermoelement used with copper for a compensating extension wire used with thermocouple types R and S. The EMF characteristics are similar to R and S up to approximately 204°C .

Alpha (α) — The temperature coefficient of resistance of a material, derived from measurements at 0°C and at 100°C : $\{R_{\text{sub}(100)} - R_{\text{sub}(0)}\}$ over $\{100 \text{ times } R_{\text{sub}(0)}\}$. It indicates the basic change in resistance in a material for each $^{\circ}\text{C}$ change in temperature. It is a defining parameter for resistance temperature detectors (RTDs).

ANSI — An abbreviation for American National Standards Institute.

ASTM — An abbreviation for American Society for Testing and Materials.

AWG — An abbreviation for American Wire Gauge.

Boiling Point — The equilibrium temperature between a liquid and its vapor. It is commonly associated with water at 100°C , and 1 standard atmosphere.

Callendar - van Dusen Equation — An interpolation equation that provides resistance values as a function of temperature for RTDs.

Celsius Temperature Scale — A temperature scale with the ice point at 0 and the boiling point of water at 100. The formula for conversion to the Fahrenheit scale is $F = 1.8C + 32$. Formerly referred to as "Centigrade."

Ceramic Insulation — Crystalline compounds of both metallic and nonmetallic elements that serve as dielectric insulators. Two of the most common single oxide ceramics are alumina (Al_2O_3) and magnesium oxide (MgO). Ceramics are the primary insulation used to isolate sheathed thermocouple alloys.

Compensated Connector — A thermocouple connector that utilizes either actual thermocouple material contacts or compensating alloy contacts. By maintaining uniform circuit properties throughout the connection systems, errors due to mismatched materials are reduced.

Compensating Alloy — An alloy that has similar EMF characteristics to an actual thermocouple alloy. It is usually a low-cost alternative for some types of thermocouple alloy extension lead wires. An example would be the use of Alloy #11 as compensating lead wire for platinum thermocouple sensors.

Compensating Loop — Utilized in RTDs, a compensating loop is an extra pair of lead wires that have the same resistance as the actual lead wires, but which are not connected to the RTD element. Its purpose is to correct for lead wire resistance errors when making temperature measurement.

Connection Head — A housing on a sensor assembly that provides a terminal block for electrical connections and allows the attachment of protection tubes and cable or conduit hookups.

Constantan — The negative leg of types E, J and T thermocouples. Constantan is 55% copper and 45% nickel. The emf values can be significantly different for this material depending upon with which type of thermocouple alloy it is intended to be matched.

Copper — The positive leg of type T thermocouple.

Cryogenic — A term that usually refers to temperatures in the range of -183°C or lower.

Dielectric Strength — A measure of the voltage that an insulating material can withstand before an electrical breakdown occurs. It is sometimes referred to as breakdown potential.

DIN 43760 — German Institute for Standards document that covers nickel and platinum resistance elements. This is the most popular specification for 100 ohm platinum RTDs with a resistance vs. temperature curve specified by 0.00385 ohms/ohm $^{\circ}\text{C}$.

Drain Wire — An uninsulated wire used in a cable construction as a ground connection.

Duplex Construction — A cable or wire constructed with two insulated conductors running parallel or twisted together.

Exposed Junction — A specific type of thermocouple junction where the measuring junction is exposed to the environment without any protecting sheath or outer tube. An exposed junction offers the fastest response time.

Extension Wire — A pair of wires connecting a thermocouple sensor to its reference junction or instrumentation. The emf characteristics of the extension wire must be similar to the thermocouple emf characteristics.

Fahrenheit Temperature Scale — A temperature scale with the ice point at 32 and the boiling point of water at 212. The formula for conversion to the Celsius scale is $C = 5/9 (F - 32)$.

FEP — An abbreviation for Fluorinated Ethylene Propylene. This component is commonly referred to as "Teflon[®]."

Fixed Point — A very reproducible temperature at the equilibrium point between phase changes in a material. The triple point of water (0.01°C) is an example of a fixed point.

Freezing Point — The fixed temperature point of a material that occurs during the transition from a liquid to a solid state. This is also known as the melting point for pure materials.

Giga- — A prefix meaning billion, or 10^9 . The symbol is G.

Ground — A conducting connection to earth or to some other large conducting object. Its purpose is to maintain an earth potential on the conductors connected to it, and to conduct the ground current to and from the earth.

Grounded Junction — A specific type of thermocouple junction in which the sheath and conductors are welded together, forming a completely sealed integral junction. A grounded junction is recommended for use in liquids, gas, and high pressure environments.

Hi-Pot Test — A test that determines the largest potential that can be applied to a conductor without breaking down the insulation (see Dielectric Strength).

Ice Point — The melting (and freezing) point of ice, 0°C . The ice point is frequently used as a calibration check point on resistance temperature detectors and as the reference junction for thermocouples.

Initial Calibration Tolerances — The allowable deviation from the theoretical emf value generated by any particular calibration thermocouple at a given temperature (previously referred to as limits of error).

Insulation Resistance — A ratio of the applied voltage to the total current flow between two conductors separated by insulation or any conductor and the sheath.

Interchangeability — A statement that describes how closely a sensor adheres to its defining equation, and the maximum variation that would exist in the readings of identical sensors mounted side-by-side under identical conditions.

IPTS- 68, 48 — Abbreviations for the International Practical Temperature Scales of 1968 and 1948. IPTS-68 is the most recent revision of the temperature scale, which is a standard scale made up of fixed points that closely approximate thermodynamic temperatures. All temperatures between the fixed points are derived by interpolation using the assigned interpolation instrument.

Iron — The positive leg of a type J thermocouple.

ISA — An abbreviation for the Instrument Society of America.

Junction (thermocouple) — The point at which two thermocouple alloys are joined. In a typical thermocouple circuit there is a measuring junction and a reference junction.

Kelvin Temperature Scale — Also known as the thermodynamic temperature scale, the Kelvin Scale is an absolute temperature scale in which temperature differences are proportional to the amount of heat energy converted to mechanical work by a Carnot engine. The ice point on the Kelvin Scale is 273.15K . A useful approximation for conversion of the Kelvin Scale to the Celsius scale is $T(\text{K}) = T(\text{C}) + 273.15$.

KN — The negative leg of a type K thermocouple. It is predominantly nickel with small added amounts of aluminum, manganese, and silicon. Company trade names are Alumel, Nial, and HAI-KN.

KP — The positive leg of a type K thermocouple. It is predominantly nickel with added chromium. Company trade names are Chromel, Tophel, and HAI-KP.

Limit of Error — The allowable error in a thermocouple, expressed as a percentage or a specific degree value throughout defined temperature ranges. See Initial Calibration Tolerances.

CONTINUED 

Glossary of Temperature Sensing Terms (continued)

Linearity — An instrument or transducer's deviation in response from straight line values.

Loop Resistance — The total resistance of the thermocouple materials in a thermocouple circuit or heater in a heater circuit.

Measuring Junction — The junction in a thermocouple circuit that senses the temperature of the unknown object. It is commonly referred to as the hot junction.

Mega- — A prefix meaning million, or 10^6 . The symbol is M.

Mica — A silicate mineral used mainly as an electrical and heat insulator.

Microvolt (μV) — One millionth of a volt (10^{-6} volt). In thermocouple measurements, a microvolt is the smallest common increment of output.

Millivolt (mV) — One thousandth of a volt.

Mineral-Insulated Thermocouple — A thermocouple that is manufactured by loading a metal sheath with conductors and insulators, and then compacting the entire assembly.

Negative Temperature Coefficient — A characteristic of a material in which a decrease in resistance accompanies an exposure to increased temperatures.

NEMA — An abbreviation for the National Electrical Manufacturers Association.

Nicrosil — The positive leg of a type N thermocouple. It is predominantly nickel with added chromium and silicon.

NISIL — The negative leg of a type N thermocouple. It is predominantly nickel with added silicon and magnesium.

NIST — National Institute of Standards and Technology.

Noise — Unwanted electrical interference picked up on a signal cable.

NPT — An abbreviation for American National Standard taper pipe thread.

OFHC — An abbreviation for oxygen free high conductivity copper.

Parallel Pair — A wire construction where two single conductors are laid parallel.

Platinel — An Englehard Industries trade name for a platinum thermocouple alloy with thermoelectric characteristics that closely match type K thermocouples at temperatures above 800°C .

Platinum — The negative leg in types R and S thermocouples. A noble metal, symbol Pt, with excellent chemical and heat resistance. It is more ductile than silver, gold, or copper.

Platinum 6% Rhodium — The platinum-rhodium alloy that forms the negative leg on type B thermocouple.

Platinum 10% Rhodium — The platinum-rhodium alloy that forms the positive leg on a type S thermocouple.

Platinum 13% Rhodium — The platinum-rhodium alloy that forms the positive leg on a type R thermocouple.

Platinum 30% Rhodium — The platinum-rhodium alloy that forms the positive leg on a type B thermocouple.

Platinum 67 — The platinum standard used by the NIST. Platinum 67 is used to interpolate the temperature scale between 630.74 and 1064.43°C . Previously called Platinum 27, Platinum 67 (IPTS-68) is 9 microvolts negative to Platinum 27 (IPTS-48) at 1200°C .

Positive Temperature Coefficient — A characteristic of a material in which an increase in resistance accompanies exposure to an increase in temperature.

Primary Standard — A term that applies to an instrument that meets conditions required for establishing the International Practical Temperature Scale.

Protection Tube — A tube that is designed to protect a sensor from any harsh environment or process conditions.

PTFE — An abbreviation for polytetrafluoroethylene. One of the most chemically resistant carbon based insulations.

PVC — An abbreviation for polyvinyl chloride, a thermoplastic with excellent dielectric strength and flexibility.

Rankine Temperature Scale — A temperature scale with its 0 at the absolute zero of temperature. Its degree is equal to a Fahrenheit degree, thus $T(\text{R}) = T(\text{F}) + 459.67$.

Reference Junction — The junction in a thermocouple circuit that is maintained at a constant, known temperature. It is also referred to as the cold junction and as a standard it is usually maintained at 0°C ; however, any temperature can be used.

Refractory Metal Thermocouple — A thermocouple made from materials that melt above 1935°C .

Repeatability — The ability of a sensor or system to indicate the same reading under repeated identical conditions.

Resistance — A property of conductors that determines the current produced by a given difference of potential. Dimensions, material and temperature all influence resistance.

Response Time — The time required for a sensor to reach 63.2% of the step change in temperature for a particular set of test conditions.

Rhenium — An elementary metal that when added to tungsten, forms an alloy with better ductility and improved high temperature strength over tungsten alone.

Rhodium — A platinum group metal added to pure platinum as a mild hardware and to increase high-temperature strength.

Ro — The resistance measurement taken on an RTD at 0°C .

RTD — An abbreviation for resistance temperature detector. It is a circuit element whose resistance increases with increasing temperature in a predictable manner. Platinum is the most popular material used in RTDs.

Secondary Standard — A measurement device that has been referenced to a primary standard.

Seebeck Coefficient — The rate of change of thermal emf with temperature at a given temperature.

Seebeck emf — The net thermal emf in a thermocouple under zero current conditions.

Shield — A metallic foil or braided wire layer surrounding a conductor or a group of conductors to prevent electrostatic or electromagnetic interferences from external sources.

Stability — The ability of an instrument or a sensor to maintain a consistent output with the application of a constant input.

Temperature Calibration Point — A temperature at which the output of a sensor is compared or determined by comparison against a standard.

Tera- — A prefix meaning trillion, or 10^{12} . The symbol is T.

Thermal Gradient — The distribution of differential temperatures in and across an object.

Thermistor — A contraction for thermally sensitive resistor. A thermistor is a semiconducting circuit element that typically exhibits a high negative coefficient of resistance.

Thermocouple — A temperature sensor formed by joining two dissimilar metals and applying a temperature differential between the measuring junction and the reference junction.

Thermopile — Multiple thermocouples connected in series so that alternate junctions are at the reference and measuring points. The result of this type of arrangement is an increased output for a given temperature differential.

Thermowell — A closed-end tube that will accept a temperature sensor and provide a pressure-tight connection at the well's point of installation.

Transducer — A device that receives and transmits energy. In many instances, the energy that is received is transmitted in a different form.

Transmitter — An externally powered device that transmits a signal from a thermocouple or an RTD via a two-wire current loop.

Triple Point of Water — A thermodynamic state (of water) in which the gas, liquid, and solid phases all occur in equilibrium. For water, the triple point is 0.01°C .

Twisted Pair — Two insulated conductors twisted together. Twisted wires in thermocouple circuits minimize magnetic noise produced from current carrying conductors.

Ungrounded Junction — A thermocouple junction that is fully insulated from the capped sheath end. An ungrounded junction is often specified for applications involving frequent or rapid temperature cycling, and for protection against stray emf signals.

Working Standard — A measurement device that has been referenced to a secondary standard.



Table Of Contents

Pictorial Index	A-41	Sleeving, Armor Cable, Wire Braid	15-14
High Temperature Lead Wire	15-2	High Temperature Electrical Plugs	15-14
PTFE Lead Wire	15-3	Plugs and Terminal Boxes	15-15
Thermocouple Wire	15-4	Insulation Blankets	15-16
High Temperature Wire Harness	15-5	Heater Accessories — Electrical Tape & Terminal Lugs	15-18
Resistance Wire & Ribbon	15-6	Irreversible Temperature Strips & Indicators	15-18
Ceramic Terminal Blocks & High Temperature Wire Nuts	15-10		
Ceramic Heater Accessories	15-13		

15

section

Accessories



High Temperature Lead Wire

High Temperature Type MG (550°C), Type MG (450°C) and Type TGGT (250°C) Lead Wire



All of Tempco's High Temperature Lead Wires are designed for:

- > Internal wiring for commercial and industrial heating products
- > Heaters
 - > Heat treating furnaces and kilns
 - > Commercial food service equipment
 - > Oven Wiring



Stock Lead Wire

Type MG – 600 Volt, 550°C (1022°F), UL 5400

Insulation Type – Mica/Glass (MG) Composite
 Conductor Material – Nickel Clad Copper (NCC)
 (27% Nickel by weight)

Wire Gauge	Nominal OD (in)	Stranding Num./Ga.	Maximum Amps @40°C	Feet per Spool	Part Number	Feet per Spool	Part Number	Feet per Spool	Part Number	Feet per Spool	Part Number
18	0.124	16/30	23	100	LDWR-1163	250	LDWR-1168	500	LDWR-1173	1000	LDWR-1178
16	0.138	26/30	30	100	LDWR-1164	250	LDWR-1169	500	LDWR-1174	1000	LDWR-1179
14	0.158	41/30	45	100	LDWR-1165	250	LDWR-1170	500	LDWR-1175	1000	LDWR-1180
12	0.182	65/30	56	100	LDWR-1166	250	LDWR-1171	500	LDWR-1176	1000	LDWR-1181
10	0.212	105/30	75	100	LDWR-1167	250	LDWR-1172	500	LDWR-1177	1000	LDWR-1182

Stock Lead Wire

Type MG – 600 Volt, 450°C (842°F), UL 5335/5107

Insulation Type – Mica/Glass (MG) Composite
 Conductor Material – Nickel Clad Copper (NCC)
 (27% Nickel by weight)



Wire Gauge	Nominal OD (in)	Stranding Num./Ga.	Maximum Amps @40°C	Feet per Spool	Part Number	Feet per Spool	Part Number	Feet per Spool	Part Number	Feet per Spool	Part Number
18	0.115	16/30	23	100	LDWR-1088	250	LDWR-1098	500	LDWR-1142	1000	LDWR-1152
16	0.134	26/30	30	100	LDWR-1089	250	LDWR-1099	500	LDWR-1143	1000	LDWR-1153
14	0.143	41/30	45	100	LDWR-1090	250	LDWR-1100	500	LDWR-1144	1000	LDWR-1154
12	0.166	65/30	56	100	LDWR-1091	250	LDWR-1101	500	LDWR-1145	1000	LDWR-1155
10	0.203	105/30	75	100	LDWR-1092	250	LDWR-1102	500	LDWR-1146	1000	LDWR-1156

Stock Lead Wire

Type TGGT – 600 Volt, 250°C (482°F), UL 5256

Insulation Type – Teflon®/Glass/Glass/Teflon® (TGGT)
 Conductor Material – Nickel Plated Copper (NPC)
 (2% Nickel by weight)



Wire Gauge	Nominal OD (in)	Stranding Num./Ga.	Maximum Amps @40°C	Feet per Spool	Part Number	Feet per Spool	Part Number	Feet per Spool	Part Number	Feet per Spool	Part Number
18	0.094	19/30	20	100	LDWR-1093	250	LDWR-1103	500	LDWR-1147	1000	LDWR-1157
16	0.103	26/30	26	100	LDWR-1094	250	LDWR-1104	500	LDWR-1148	1000	LDWR-1158
14	0.118	41/30	39	100	LDWR-1095	250	LDWR-1105	500	LDWR-1149	1000	LDWR-1159
12	0.136	65/30	54	100	LDWR-1096	250	LDWR-1106	500	LDWR-1150	1000	LDWR-1160
10	0.174	105/30	73	100	LDWR-1097	250	LDWR-1107	500	LDWR-1151	1000	LDWR-1161

Type PTFE (200°C/392°F) Lead Wire



Stock Lead Wire

Type PTFE – 300 Volt, 200°C (392°F) UL 1180

Insulation Type – PTFE

Conductor Material – Silver Plated Copper (SPC)

Insulation Color: Red

Wire Gauge	Nominal OD (in)	Stranding Num./Ga.	Maximum Amps @40°C	Feet per Spool	Part Number
22	0.056	19/34	9.6	100	LDWR-1112
20	0.064	19/32	14	100	LDWR-1111
18	0.073	19/30	18	100	LDWR-1110
16	0.079	19/29	24	100	LDWR-1109
14	0.093	19/27	36	100	LDWR-1108
22	0.056	19/34	9.6	250	LDWR-1127
20	0.064	19/32	14	250	LDWR-1126
18	0.073	19/30	18	250	LDWR-1125
16	0.079	19/29	24	250	LDWR-1124
14	0.093	19/27	36	250	LDWR-1123

Insulation Color: White

Wire Gauge	Nominal OD (in)	Stranding Num./Ga.	Maximum Amps @40°C	Feet per Spool	Part Number
22	0.056	19/34	9.6	100	LDWR-1117
20	0.064	19/32	14	100	LDWR-1116
18	0.073	19/30	18	100	LDWR-1115
16	0.079	19/29	24	100	LDWR-1114
14	0.093	19/27	36	100	LDWR-1113
22	0.056	19/34	9.6	250	LDWR-1132
20	0.064	19/32	14	250	LDWR-1131
18	0.073	19/30	18	250	LDWR-1130
16	0.079	19/29	24	250	LDWR-1129
14	0.093	19/27	36	250	LDWR-1128

Insulation Color: Black

Wire Gauge	Nominal OD (in)	Stranding Num./Ga.	Maximum Amps @40°C	Feet per Spool	Part Number
22	0.056	19/34	9.6	100	LDWR-1122
20	0.064	19/32	14	100	LDWR-1121
18	0.073	19/30	18	100	LDWR-1120
16	0.079	19/29	24	100	LDWR-1119
14	0.093	19/27	36	100	LDWR-1118
22	0.056	19/34	9.6	250	LDWR-1137
20	0.064	19/32	14	250	LDWR-1136
18	0.073	19/30	18	250	LDWR-1135
16	0.079	19/29	24	250	LDWR-1134
14	0.093	19/27	36	250	LDWR-1133



Note: Recommended Maximum Amperage is based on an Ambient Temperature of 40°C (104°F) and not more than three current carrying conductors in a raceway/conduit or bundled and directly buried. For de-rating factors for higher ambient temperatures consult Tempco's engineering data on page 16-10. For more information consult the National Electrical Code, Articles 310-15 through 310-84.

NOTE: For nickel wire conductor and other high temperature lead wire—consult Tempco.

Thermocouple Wire

ANSI Type J and K Duplex Thermocouple Wire — Stocked on 100 and 250 Foot Spools

Can be used for manufacturing thermocouple assemblies or as hook up wire between a thermocouple assembly and display instrumentation or a temperature control. The calibration is guaranteed to the full temperature range of the thermocouple type.



TC Type	Wire Type	Insulation	Insulation Temperature Limits (°F/°C)	Nominal Overall Dimensions (inches)	Part Number	
					100 Foot Spool	250 Foot Spool
J	20 Gauge Solid	Fiberglass	900/482	.060 × .106	TCWR-1028	TCWR-1032
J	20 Gauge Stranded	Fiberglass	900/482	.066 × .118	TCWR-1033	TCWR-1035
J	24 Gauge Solid	Fiberglass	900/482	.048 × .082	TCWR-1037	TCWR-1069
J	24 Gauge Stranded	Fiberglass	900/482	.048 × .082	TCWR-1038	TCWR-1070
J	20 Gauge Stranded	Fiberglass with SS overbraid	900/482	.088 × .140	TCWR-1047	TCWR-1051
J	20 Gauge Solid	FEP Teflon®	400/204	.068 × .116	TCWR-1060	TCWR-1062
J	24 Gauge Stranded	Fiberglass with SS overbraid	900/482	.074 × .100	TCWR-1048	TCWR-1052
K	20 Gauge Solid	Fiberglass	900/482	.060 × .116	TCWR-1025	TCWR-1029
K	20 Gauge Stranded	Fiberglass	900/482	.066 × .118	TCWR-1034	TCWR-1036
K	24 Gauge Solid	Fiberglass	900/482	.044 × .074	TCWR-1039	TCWR-1071
K	24 Gauge Stranded	Fiberglass	900/482	.050 × .082	TCWR-1040	TCWR-1072
K	20 Gauge Stranded	Fiberglass with SS overbraid	900/482	.088 × .140	TCWR-1049	TCWR-1053
K	20 Gauge Solid	FEP Teflon®	400/204	.068 × .116	TCWR-1061	TCWR-1063
K	24 Gauge Stranded	Fiberglass with SS overbraid	900/482	.074 × .100	TCWR-1050	TCWR-1054

ANSI Type JX and KX Thermocouple Extension Wire — Stocked on 100 and 250 Foot Spools

Due to its cost advantage thermocouple extension wire is used to make the connection between the thermocouple assembly and the measuring instrument, especially when long distances are involved. Thermocouple extension wire has approximately the same characteristics as thermocouple wire but its accuracy is guaranteed over a limited temperature range.



TC Type	Wire Type	Insulation	Insulation Temperature Limits (°F/°C)	Nominal Overall Dimensions (inches)	Part Number	
					100 Foot Spool	250 Foot Spool
JX	20 Gauge Solid	PVC	221/105	.092 × .154	TCWR-1027	TCWR-1031
JX	20 Gauge Stranded	PVC	221/105	.098 × .166	TCWR-1041	TCWR-1073
JX	24 Gauge Solid	PVC	221/105	.080 × .130	TCWR-1042	TCWR-1074
JX	24 Gauge Stranded	PVC	221/105	.084 × .138	TCWR-1043	TCWR-1075
JX	20 Gauge Solid	PVC with Shield & Drain	221/105	.169 Diameter	TCWR-1055	TCWR-1057
KX	20 Gauge Solid	PVC	221/105	.092 × .154	TCWR-1026	TCWR-1030
KX	20 Gauge Stranded	PVC	221/105	.098 × .166	TCWR-1044	TCWR-1076
KX	24 Gauge Solid	PVC	221/105	.080 × .130	TCWR-1045	TCWR-1077
KX	24 Gauge Stranded	PVC	221/105	.084 × .138	TCWR-1046	TCWR-1078
KX	20 Gauge Solid	PVC with Shield & Drain	221/105	.169 Diameter	TCWR-1056	TCWR-1058

Tempco's Thermocouple Wire and Extension Wire is supplied to meet Standard Tolerances of ANSI Circular MC96.1-1982.

For Thermocouple Wire Types and Special Limits/Tolerances not shown, refer to catalog pages 14-102 through 14-113 in the Temperature Sensors section.

High Temperature Wire Harness

Tempco's High Temperature Ceramic Insulated Wire Harnesses are designed from the ground up, starting with specially selected High Temperature Alloy Wire chosen for its ability to carry the rated current at the required temperature and provide long life.

- Ceramic beads are used for making turns and to provide flexibility at the terminal area.
- Solid ceramic pieces are used for straight runs.
- Ceramic terminal blocks are used for lead connections.

Ordering Information

Send all requirements, drawings or samples to Tempco for a fully detailed quote proposal that will meet your requirements. **Standard lead time is typically 2 weeks.**

Are You Having Problems With Your Wire Harnesses In High Temperature Applications?

Tempco has the design experience in the plastics industry and the manufacturing capability to handle your OEM requirements for many types of wire harness.

Due to our many years of manufacturing electric heaters, we are very familiar with the problems high temperature environments can cause to wiring and connectors.

We have the solutions to your difficult wiring applications!

Applications

- * Injection Molding Barrel
- * Plastic Extrusion Barrel
- * Aircraft Industry Composite Resin Lamination
- * Food Service Equipment
- * Furnaces
- * Ovens
- * Heat Treatment
- * Foundry Industry

Services Rendered

- * Custom Harness Manufacturing
- * Contract Assembly & Manufacturing
- * Automatic Cut & Strip
- * Wire Processing
- * Automatic & Hand Termination
- * Wire Bundling: Fiberglass Tape, Metal Strapping, Tie Wraps
- * Individual Wire ID Markings

Materials Used

- * Specially Selected High Temperature Conductors
- * UL and CSA Rated Wire
- * High Temperature Insulation
- * 600-Volt Gated Insulation
- * Sleeving and Tubing
- * Armor and Braid
- * UL and CSA Rated Connectors
- * Multi-Pin Connectors

TEMPCO HAS THE SOLUTION TO POWER UP YOUR INSTALLATION!

⚠ WARNING: Cancer and Reproductive Harm - www.P65Warnings.ca.gov.

(800) 323-6859 • Email: sales@tempco.com



Resistance Wire

Resistance Wire

TEMPCO stocks a large amount of resistance wire that is required in our own manufacturing. We have made this inventory available to you for use in applications such as industrial heating, kilns, process heating and small-scale manufacturing.

The resistance wire is offered both in round wire and ribbon.

Type A: Wire only 2190°F (1200°C)

Type C: Wire 2100°F (1150°C) Ribbon 2055°F (1125°C)

Type D: Wire only 2370°F (1300°C)

"A" Wire (Kanthal Nikrothal 80 or Equivalent)

Composition: 80% Nickel, 20% Chromium

Specific Resistance: 650 Ohms / circ. mil foot @ 68°F / 20°C

Maximum continuous

operating temperature: 2190°F / 1200°C
(element temperature in air)

Melting Point: 1400°C / 2552°F

Density: (lbs/in³): 0.304

Specific Gravity: 8.41

Resistance Tolerance: 8 ga. through 23 ga. ±3%, 24 ga. through 36 ga. ±5%, 37 ga. through 43 ga. ±8%



Note: To obtain the working temperature resistance, multiply the factor by the room temperature resistance.

Temp. °F	68	200	400	600	800	1000	1200	1400	1600	1800	2000
Temp. °C	20	93	204	315	427	538	649	760	871	982	1093
Factor	1.000	1.016	1.037	1.054	1.066	1.070	1.064	1.062	1.066	1.072	1.078

(These figures are given as a basis for engineering calculations and represent average material as supplied.)

Part Number	Gauge	Diameter	Resistance at 68°F/20°C ohms/ft.	Weight lb./1000 ft.	Length ft./lb.	Nominal Spool Weight	Standard Spool Size Code
RES-101-142	8	0.128	0.03967	46.7	21.4	24	—
RES-101-132	9	0.114	0.05001	37.0	27.0	24	—
RES-101-131	12	0.081	0.09907	18.5	54.1	24	—
RES-101-102	17	0.045	0.3209	5.80	172.4	6	D
RES-101-130	18	0.040	0.4062	4.59	217.9	10	D
RES-101-103	19	0.036	0.5015	3.64	274.7	9	D
RES-101-104	20	0.032	0.6347	2.90	344.8	10	D
RES-101-105	21	0.0285	0.8002	2.30	434.8	8	D
RES-101-106	22	0.0253	1.017	1.81	552.5	9	D
RES-101-107	23	0.0226	1.272	1.44	694.4	5	C
RES-101-108	24	0.0201	1.609	1.14	877.2	10	D
RES-101-109	25	0.0179	2.029	0.906	1104	5	C
RES-101-110	26	0.0159	2.571	0.715	1399	2	F
RES-101-111	27	0.0142	3.228	0.570	1754	2	F
RES-101-112	28	0.0126	4.090	0.449	2227	3.5	F
RES-101-113	29	0.0113	5.090	0.361	2770	3.5	F
RES-101-114	30	0.0100	6.500	0.283	3534	2.25	F
RES-101-115	31	0.0089	8.206	0.224	4465	2.25	F
RES-101-116	32	0.0080	10.16	0.181	5525	2.5	F
RES-101-117	33	0.0071	12.90	0.143	6993	1.75	F
RES-101-118	34	0.0063	16.37	0.112	8929	2	B
RES-101-119	35	0.0056	20.72	0.0887	11,274	1	A
RES-101-120	36	0.0050	26.00	0.0707	14,144	1	A
RES-101-121	37	0.0045	32.09	0.0573	17,452	1	A
RES-101-122	38	0.0040	40.62	0.0452	22,124	1	A
RES-101-123	39	0.0035	53.06	0.0346	28,901	1	A
RES-101-124	40	0.0031	67.63	0.0272	36,765	1	A
RES-101-125	41	0.0028	85.98	0.0222	45,045	0.5	A
RES-101-126	42	0.0025	104.0	0.0177	56,497	0.3	A
RES-101-127	43	0.0022	128.5	0.0137	72,993	0.35	A



All Items Available from Stock

Cross Reference Chart

Kanthal	Hoskins	Driver-Harris	Carpenter	Rescal	Calfine Wire	Harrison	Thyssen Krup VDM	MWS Wire	Jelliff	Molecu
Nikrothal 60	Chromel C	Nichrome	Tophet C	Resistohm 60	Stablohm 675	HAI-NiCr 60	Cronifer II	MWS-675	Alloy C	Electroloy
Nikrothal 80	Chromel A	Nichrome V	Tophet A	Resistohm 80	Stablohm 650	Nichrome V	Cronix 80	MWS-650	Alloy A	Protoloy
Kanthal D	Alloy 815	—	Alchrome DK	Resistohm 135	Stablohm 812	Alferon 901	Aluchrom 5	—	—	—

"C" Wire (Kanthal Nikrothal 60 or Equivalent)

Composition: 60% Nickel, 16% Chromium, Fe balance

Specific Resistance: 675 Ohms / circ. mil foot @ 68°F / 20°C

Maximum continuous

operating temperature: 2100°F / 1150°C
(element temperature in air)

Melting Point: 1350°C / 2462°F

Density: (lbs / in³): 0.298

Specific Gravity: 8.25

Resistance Tolerance: 16 ga. through 23 ga. ±3%, 24 ga. through 36 ga. ±5%, 37 ga. through 44 ga. ±8%



Note: To obtain the working temperature resistance, multiply the factor by the room temperature resistance.

Temp. °F	68	200	400	600	800	1000	1200	1400	1600
Temp. °C	20	93	204	315	427	538	649	760	871
Factor	1.000	1.019	1.044	1.070	1.092	1.108	1.112	1.118	1.130

(These figures are given as a basis for engineering calculations and represent average material as supplied.)

Part Number	Gauge	Diameter	Resistance at 68°F/20°C ohms/ft.	Weight lb./1000 ft.	Length ft./lb.	Nominal Spool Weight	Standard Spool Size Code
RES-103-102	16	0.051	0.2595	7.20	138.9	8	D
RES-103-103	17	0.045	0.3333	5.72	174.8	10	D
RES-103-104	18	0.040	0.4219	4.53	220.8	10	D
RES-103-105	19	0.036	0.5208	3.60	277.8	8	D
RES-103-106	20	0.032	0.6592	2.86	349.7	10	D
RES-103-107	21	0.0285	0.8310	2.27	440.5	10	D
RES-103-108	22	0.0253	1.055	1.79	558.7	9	D
RES-103-109	23	0.0226	1.322	1.42	704.2	6	C
RES-103-110	24	0.0201	1.671	1.13	885.0	5	C
RES-103-111	25	0.0179	2.107	0.894	1119	5	C
RES-103-112	26	0.0159	2.670	0.705	1418	1.5	B
RES-103-113	27	0.0142	3.348	0.563	1776	5	C
RES-103-114	28	0.0126	4.251	0.443	2257	5	C
RES-103-115	29	0.0113	5.286	0.356	2809	5.25	C
RES-103-116	30	0.0100	6.750	0.279	3584	2	B
RES-103-117	31	0.0089	8.523	0.221	4525	3	F
RES-103-118	32	0.0080	10.55	0.179	5587	3	F
RES-103-119	33	0.0071	13.39	0.141	7092	2	B
RES-103-120	34	0.0063	17.00	0.111	9009	2	B
RES-103-121	35	0.0056	21.52	0.0875	11,429	0.75	A
RES-103-122	36	0.0050	27.00	0.0697	14,347	1	A
RES-103-123	37	0.0045	33.33	0.0565	17,699	0.75	A
RES-103-124	38	0.0040	42.19	0.0446	22,422	0.75	A
RES-103-125	39	0.0035	55.10	0.0342	29,240	1	A
RES-103-126	40	0.0031	70.24	0.0268	37,313	1	A
RES-103-127	41	0.0028	89.29	0.0219	45,662	0.25	A
RES-103-128	42	0.0025	108.0	0.0174	57,471	0.5	A
RES-103-129	43	0.0022	133.4	0.01422	70,320	0.5	A
RES-103-130	44	0.0020	168.8	0.0112	89,286	4	C

Ordering Information

- Specify the part number and quantity in lbs.
- Only full spools are available; re-spooling of smaller quantities is not available.
- Tempco reserves the right to change spool sizes as required.
- Tempco reserves the right to ship ±10% of the stated spool weight.



All Items Available from Stock

Standard Spool Dimensions

Spool Code	Flange		Barrel		Traverse		Bore ID	
	in	mm	in	mm	in	mm	in	mm
A	2.5	63	1.75	44	3	76	.62	16
B	3	76	1.75	44	3	77	.62	16
C	5	127	3	76	3.5	89	.62	16
D	6	152	3.5	89	3.5	89	.62	16
E	3.15	80	2	51	2.5	63	.62	16
F	3.87	98	2.37	59	3.12	79	.62	16
G	4.92	125	3.1	79	3.93	100	.62	16

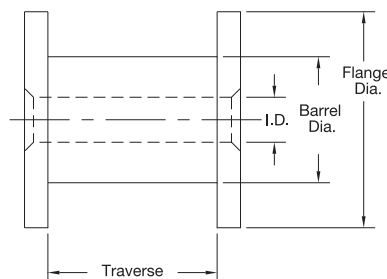

WARNING: Cancer and Reproductive Harm - www.P65Warnings.ca.gov

(800) 323-6859 • Email: sales@tempco.com



Resistance Wire

"C" Ribbon (Kanthal Nikrothal 60 or Equivalent)

Composition: 60% Nickel, 16% Chromium, Fe balance

Specific Resistance: 530 Ohms / circ. mil foot @ 68°F / 20°C

Maximum continuous

operating temperature: 2055°F / 1125°C
(element temperature in air)

Melting Point: 1350°C / 2462°F

Density: (lbs / in³): 0.298

Specific Gravity: 8.25

Resistance Tolerance: ±5%



Note: To obtain the working temperature resistance, multiply the factor by the room temperature resistance.

Temp. °F	68	200	400	600	800	1000	1200	1400	1600
Temp. °C	20	93	204	315	427	538	649	760	871
Factor	1.000	1.019	1.044	1.070	1.092	1.108	1.112	1.118	1.130

(These figures are given as a basis for engineering calculations and represent average material as supplied.)



Part Number	Width	Thickness	Resistance at 68°F/20°C ohms/ft.	Weight lb./1000 ft.	Length ft./lb.	Nominal Spool Weight	Standard Spool Size Code
RES-105-101	1/64	0.0031	11.64	0.1581	6325	2	B
RES-105-102	1/64	0.0040	9.021	0.2046	4888	1	E
RES-105-103	1/64	0.0050	7.217	0.2559	3908	1.25	E
RES-105-104	1/64	0.0056	6.445	0.2865	3490	1.75	B
RES-105-105	1/64	0.0071	5.084	0.3626	2758	2	B
RES-105-106	1/64	0.0089	4.056	0.4555	2195	2.25	F
RES-105-107	1/32	0.0040	4.511	0.4090	2445	2.25	F
RES-105-108	1/32	0.0045	4.009	0.4604	2172	2.25	F
RES-105-109	1/32	0.0050	3.609	0.5118	1954	4	G
RES-105-110	1/32	0.0056	3.222	0.5730	1745	2.25	F
RES-105-111	1/32	0.0063	2.863	0.6442	1552	3	F
RES-105-112	1/32	0.0080	2.255	0.8181	1222	4	G
RES-105-113	1/32	0.0100	1.804	1.0276	973.1	4	G
RES-105-134	1/32	0.0113	1.597	1.1263	887.9	2.5	F
RES-105-114	1/16	0.0035	2.919	0.6494	1540	4	G
RES-105-115	1/16	0.0045	2.005	0.9208	1086	2	B
RES-105-116	1/16	0.0056	1.611	1.1461	872.5	8	D
RES-105-140	1/16	0.0063	1.432	1.2844	778.6	3	F
RES-105-117	1/16	0.0071	1.271	1.4524	688.5	3	F
RES-105-118	1/16	0.0080	1.128	1.6401	609.7	2.5	F
RES-105-119	1/16	0.0089	1.014	1.8179	550.1	1.25	E
RES-105-120	1/16	0.0100	0.9021	2.0452	488.9	4.5	G
RES-105-139	1/16	0.0126	0.7160	2.6577	376.3	2.5	F
RES-105-121	1/8	0.0035	1.459	1.2980	770.4	4	G
RES-105-122	1/8	0.0040	1.277	1.4835	674.1	1	E
RES-105-123	1/8	0.0050	1.022	1.8549	539.1	4	G
RES-105-138	1/8	0.0056	0.9124	2.0777	481.3	2.5	F
RES-105-124	1/8	0.0063	0.8107	2.5787	387.8	3.5	G
RES-105-125	1/8	0.0071	0.7198	2.9047	344.3	3	F
RES-105-126	1/8	0.0080	0.6386	3.2703	305.8	4	G
RES-105-137	1/8	0.0089	0.5070	3.6358	275.0	3	F
RES-105-127	1/8	0.0100	0.4511	4.0903	244.5	4	G
RES-105-136	1/8	0.0113	0.3992	4.4954	222.4	3.5	G
RES-105-135	1/8	0.0126	0.3580	5.3154	188.1	3	F

All Items Available from Stock

Cross Reference Chart

Kanthal	Hoskins	Driver-Harris	Carpenter	Rescal	Calfine Wire	Harrison	Thyssen Krup VDM	MWS Wire	Jelliff	Molecu
Nikrothal 60	Chromel C	Nichrome	Tophet C	Resistohm 60	Stablohm 675	HAI-NiCr 60	Cronifer II	MWS-675	Alloy C	Electroloy
Nikrothal 80	Chromel A	Nichrome V	Tophet A	Resistohm 80	Stablohm 650	Nichrome V	Cronix 80	MWS-650	Alloy A	Protoloy
Kanthal D	Alloy 815	—	Alchrome DK	Resistohm 135	Stablohm 812	Alferon 901	Aluchrom 5	—	—	—

“D” Wire (Kanthal Wire or Equivalent)

Composition: 22% Chromium, 4.8% Aluminum, Fe balance
Specific Resistance: 812 Ohms / circ. mil foot @ 68°F / 20°C
Maximum continuous operating temperature: 2370°F / 1300°C
 (element temperature in air)

Melting Point: 1500°C / 2730°F
Density: (lbs/in³): 0.262
Resistance Tolerance: 17 ga. through 23 ga. ±3%, 24 ga. through 36 ga. ±5%, 37 ga. ±8%



Note: To obtain the working temperature resistance, multiply the factor by the room temperature resistance.

Temp. °F	68	200	400	600	800	1000	1200	1400	1600	1800	2000	2200	2372
Temp. °C	20	93	204	315	427	538	649	760	871	982	1093	1204	1300
Factor	1.00	1.00	1.01	1.01	1.02	1.03	1.04	1.05	1.06	1.07	1.07	1.08	1.08

(These figures are given as a basis for engineering calculations and represent average material as supplied.)

Part Number	Gauge	Diameter	Resistance at 68°F/20°C ohms/ft.	Weight lb./1000 ft.	Length ft./lb.	Nominal Spool Weight	Standard Spool Size Code
RES-106-101	17	0.045	0.3964	5.07	197.2	10	D
RES-106-142	18	0.040	0.5000	4.01	249.4	10	D
RES-106-102	19	0.036	0.6304	3.18	314.5	5	C
RES-106-143	20	0.032	0.7950	2.53	395.3	1.75	C
RES-106-107	21	0.0285	1.003	2.01	497.5	8	D
RES-106-141	22	0.0253	1.264	1.58	632.9	6	C
RES-106-106	23	0.0226	1.594	1.26	793.7	35	—
RES-106-137	24	0.0201	2.010	1.00	1000	5	C
RES-106-109	25	0.0179	2.534	0.791	1264	5.5	C
RES-106-135	26	0.0159	3.196	0.624	1603	6	C
RES-106-136	27	0.0142	4.027	0.498	2008	5	C
RES-106-110	28	0.0126	5.082	0.392	2551	5	C
RES-106-103	29	0.0113	6.404	0.315	3175	4.25	C
RES-106-138	30	0.0100	8.071	0.247	4049	1.5	B
RES-106-111	31	0.0089	10.19	0.196	5102	1.5	B
RES-106-139	32	0.0080	12.85	0.158	6329	1.5	B
RES-106-105	33	0.0071	16.20	0.124	8065	4	C
RES-106-104	34	0.0063	20.43	0.0980	10,204	5	C
RES-106-140	35	0.0056	25.75	0.0774	12,920	5	C
RES-106-112	37	0.0045	40.95	0.0500	20,000	2	B

Ordering Information

1. Specify the part number and quantity in lbs.
2. Only full spools are available; re-spooling of smaller quantities is not available.
3. Tempco reserves the right to change spool sizes as required.
4. Tempco reserves the right to ship ±10% of the stated spool weight.



All Items Available from Stock

Standard Spool Dimensions

Spool Code	Flange		Barrel		Traverse		Bore ID	
	in	mm	in	mm	in	mm	in	mm
A	2.5	63	1.75	44	3	76	.62	16
B	3	76	1.75	44	3	77	.62	16
C	5	127	3	76	3.5	89	.62	16
D	6	152	3.5	89	3.5	89	.62	16
E	3.15	80	2	51	2.5	63	.62	16
F	3.87	98	2.37	59	3.12	79	.62	16
G	4.92	125	3.1	79	3.93	100	.62	16

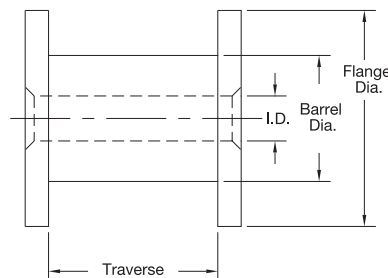

WARNING: Cancer and Reproductive Harm - www.P65Warnings.ca.gov.

(800) 323-6859 • Email: sales@tempco.com

Ceramic Terminal Blocks & Connectors

Standard Ceramic Terminal Blocks for Internal Wiring

Used for wiring of heater power and thermocouple wiring in high temperature locations.

Design Features

- * **Maximum Voltage:** 600 VAC
- * **Maximum Current:** 20 Amp
- * **Maximum Temperature:** 450°C/842°F
- * **Wire Gauge:** 20 to 12 ga.
- * **Hardware:** Stainless Steel
- * **Terminals:** #8 Screw
- * **Body Material:** Steatite

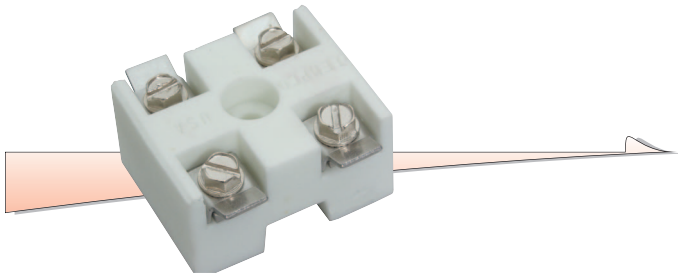

Part Number: EHD-108-101

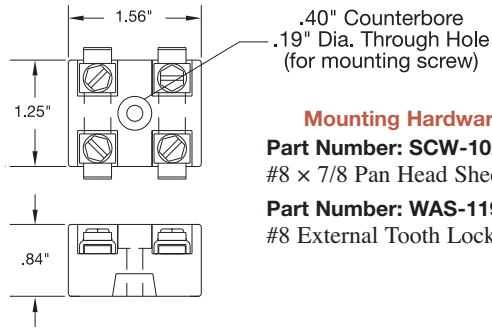

Mounting Hardware Supplied

Part Number: SCW-102-109

#8 x 7/8 Pan Head Sheet Metal Screw

Part Number: WAS-119-106

#8 External Tooth Lockwasher

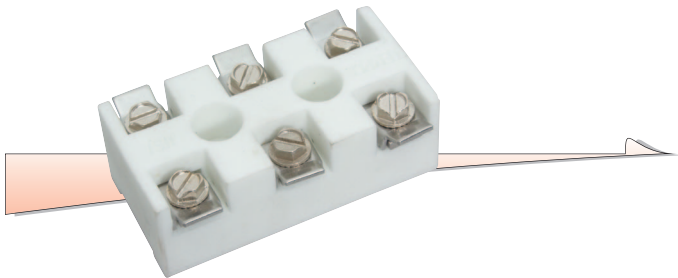

Part Number: EHD-108-121

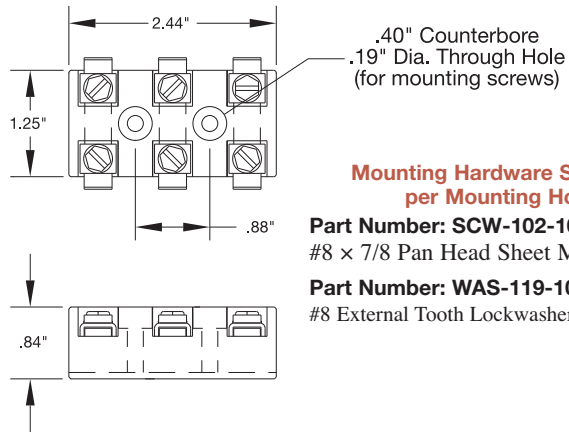

Mounting Hardware Supplied per Mounting Hole

Part Number: SCW-102-109

#8 x 7/8 Pan Head Sheet Metal Screws

Part Number: WAS-119-106

#8 External Tooth Lockwashers

Ceramic Wire Nut Connectors



Stock Number	MFR Part Number	Wire Range (Solid or Stranded Wire)		Skirt Length	Opening ID	Outer Diameter
EHD-114-102	10-401	2#22	1#18 + 1#16	.687"	.250"	.406"
EHD-114-103	10-405	2#20	2#16	.750"	.312"	.484"
EHD-114-104	10-407	2#18	2#14	.843"	.406"	.531"
EHD-114-105	-	1#16 + 1#14	1#14 + 2#12	1.00"	.468"	.703"

SPECIFICATIONS

Material: Porcelain

Maximum Temperature Rating: 1200°F (645°C)

Maximum Voltage: 300V

Agency Approvals: UL and CSA for EHD-114-102, EHD-114-103 and EHD-114-104 (UL File E9809)

All Items Available from Stock

View Product Inventory @ www.tempco.com

Ceramic Terminal Blocks (Enclosed Terminals)

Used for wiring of heater power and thermocouple wiring in high temperature locations.

Design Features

- * **Maximum Voltage:** 380 VAC
- * **Maximum Current:** 30 Amp
- * **Maximum Temperature:** 240°C/464°F
- * **Wire Gauge:** 26 to 12 ga. stranded, 26-14 solid
- * **Screw:** M3, zinc plated steel
- * **Terminal Body:** Nickel plated brass
- * **Body Material:** Porcelain
- * **Agency Approvals:** CE & VDE



Part Number: EHD-108-116

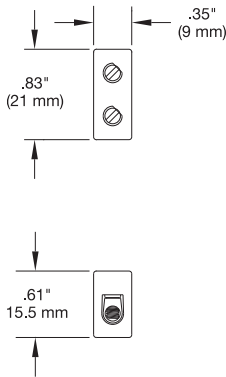

Part Number: EHD-108-117

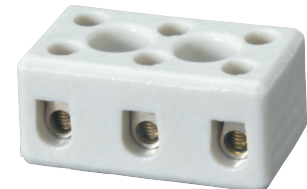
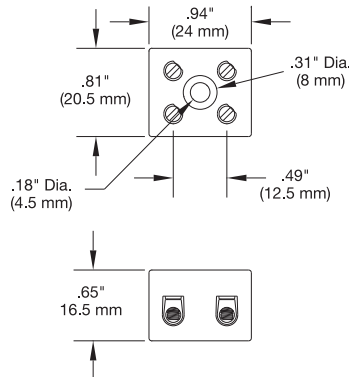

Part Number: EHD-108-118

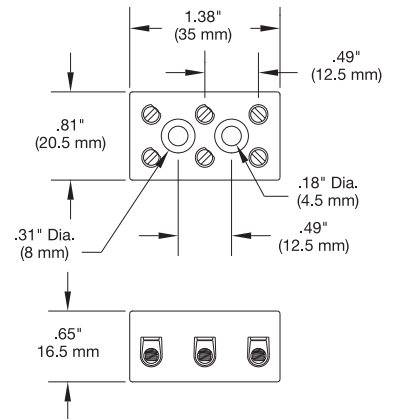

Ceramic Heavy Duty Terminal Blocks (Enclosed Terminals)

Used for wiring of heater power and thermocouple wiring in high temperature locations.

Design Features

- * **Maximum Voltage:** 600 VAC
- * **Maximum Current:** 50 Amp
- * **Maximum Temperature:** 200°C/392°F
- * **Wire Gauge:** 14 to 8 ga.
- * **Screw:** M4, zinc plated steel
- * **Terminal Body:** Nickel plated brass
- * **Body Material:** Porcelain
- * **Agency Approval:** UL, File # E69841

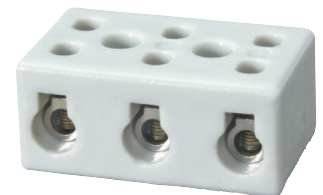
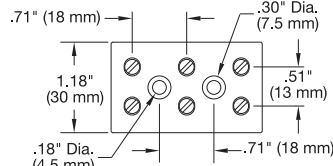
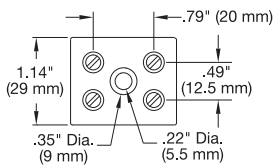

Stock Number: EHD-108-114

Stock Number: EHD-108-115

MFR Part Number: 4010-B

MFR Part Number: 4011-B

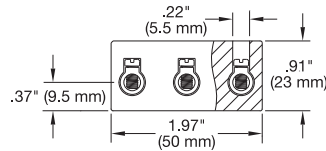
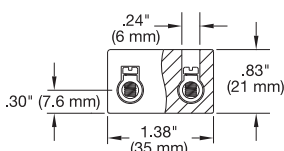

All Items Available from Stock



Ceramic Terminal Blocks

Heavy Duty High Temperature Ceramic Line Wiring Blocks (Exposed Terminals)

Used for interfacing heater assemblies, CRA housings and ARA arrays to external line wiring.

Design Features

- * **Maximum Voltage:** 500 VAC
- * **Maximum Current:** 44 Amp @ 104°F ambient
- * **Maximum Temperature:** 240°C/464°F
- * **Wire Gauge:** 18 to 8 ga.
- * **Terminal Screw:** M4, zinc-plated steel
- * **Body Material:** Steatite
- * **Agency Approvals:** None

Optional Terminal Hardware

Stainless Steel Flat Washer — Part Number: WAS-109-101

Spring Lock Washers — Part Number: WAS-118-108

Part Number: EHD-108-106

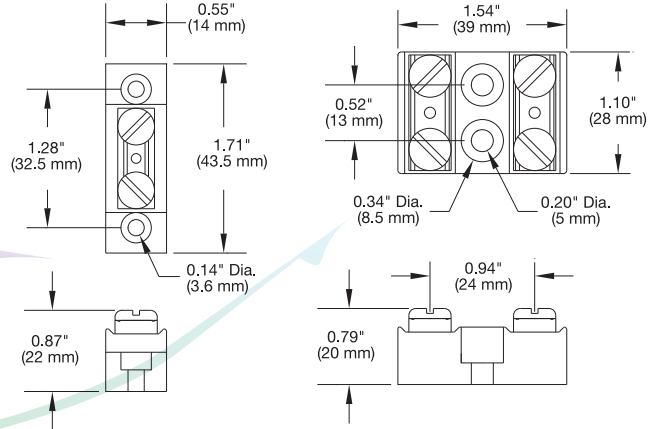

Part Number: EHD-108-107



Part Number: EHD-108-108

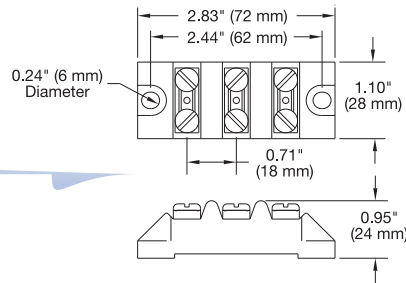

Part Number: EHD-108-109

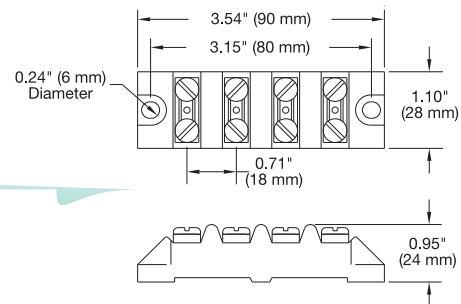

Part Number: EHD-108-105

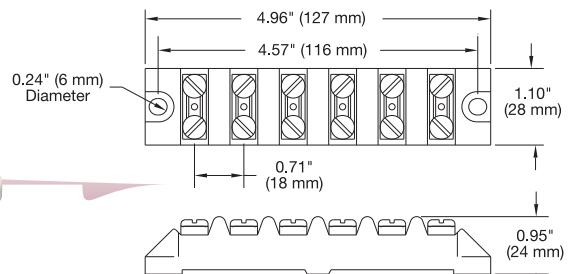

All Items Available from Stock

Stock Ceramic Accessories

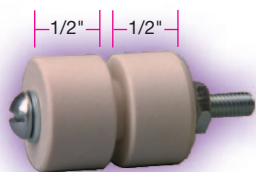

Screw Size:
10-32 x 1-3/4" long

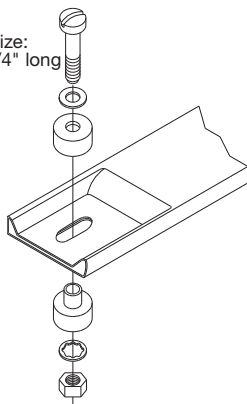

Secondary Insulating Bushings

Used to mount finned strip heaters in air heating applications. Also can be used when it is necessary to electrically isolate the heater from ground.

When Insulating Bushings are required, a 1/2" x 5/8" slot is substituted for the standard slot size (5/16" x 1/2").

Insulating Bushing Assembly

Part Number: CERR-1001

NOTE: Two assemblies are required for each heater.



When using secondary insulating bushings, the heater must be guarded to avoid any accidental contact. The guard must be electrically isolated from the heater and must be properly grounded.

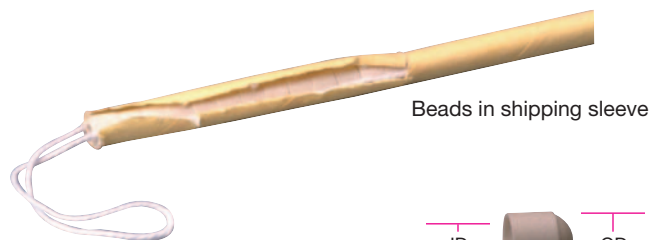

Beads in shipping sleeve

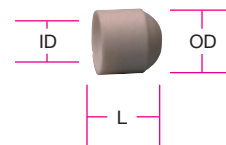

Ceramic Beads

Used to insulate bare lead wire at extremely high temperatures.

O.D. (in)	I.D. (in)	Length	Packaging	Sold By	Part Number
.110	.056	.110	67 beads/6" sleeve	Sleeve	CER-103-101
.170	.068	.170	86 beads/12" sleeve	Sleeve	CER-103-102
.200	.092	.200	36 beads/6" sleeve	Sleeve	CER-103-103
.200	.092	.200	bulk—loose	Piece	CER-103-104
.330	.124	.330	bulk—loose	Piece	CER-103-105
.203	.085	.203	bulk—loose	Piece	CER-103-108

Ceramic Covers for Insulating Screw Terminals

Used on the following heaters:

Mica Band • Ceramic Band • Mi-Plus® • Channel Strip • Finned Strip • Mica Strip

Provides an electrically safe environment on standard screw terminals.

Can be field retrofit or factory installed.

Igloo™ Ceramic Caps

Thread	Part Number
10-32	CER-102-101
10-24	CER-102-104
8-32	CER-102-105

Caps fit all Igloo™ bases below.



Ceramic Cap

Thread	Part Number
10-32	CER-102-101
10-24	CER-102-104
8-32	CER-102-105

All three caps fit conventional base.



Igloo™ Ceramic Bases

Type	Part Number
Double Port In-Line	CER-101-104
Double Port 90°	CER-101-106
Single Port	CER-101-107

Conventional Ceramic Base

Use with insulated terminals only.

Part Number: CER-101-101



Ceramic Cap CER-102-103 and Base CER-101-103 below are primarily used on cast-in .430 diameter tubular heating elements



Description	Part Number
Ceramic Cap w/10-32 thread	CER-102-103
Ceramic Base – .430 diameter	CER-101-103

All Items Available from Stock

Lead Wire Protection and Plugs

Lead Wire Protection and High Temperature Electrical Plugs

High Temperature Fiberglass Slewing

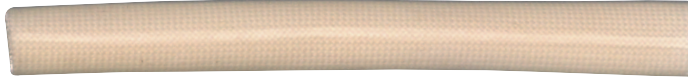

The fiberglass slewing is first annealed to remove all organic matter and then uniformly coated with highly abrasion-resistant silicone rubber, which provides an excellent secondary insulation for greater dielectric strength and added protection against abrasion and wire contamination.

Temperature Range: -70°C to 180°C (-94°F to 356°F)

Order by the foot: 50 ft. minimum

NEMA Size	Nom. I.D. (in)	Part Number
24	0.024	SLV-101-113
20	0.036	SLV-101-112
16	0.056	SLV-101-111
12	0.086	SLV-101-110
10	0.107	SLV-101-109
8	0.135	SLV-101-108
5	0.186	SLV-101-107
4	0.208	SLV-101-106
3	0.234	SLV-101-104
2	0.263	SLV-101-102
0	0.330	SLV-101-101
3/8"	0.387	SLV-101-114

Flexible Armor Cable



Stainless Steel or Galvanized Steel

Used to protect lead wire against abrasion or physical damage in hazardous environments; provides protection from excessive flexing.

Order by the foot: 50 ft. minimum

I.D. (in)	O.D. (in)	Part Number		* Anti-Short Bushing (Plastic)
		Galv. Steel	Stainless Steel	
3/16	9/32	CAB-101-101	CAB-102-102	CAB-106-101
1/4	3/8	CAB-101-108	CAB-102-104	CAB-106-102
5/16	7/16	CAB-101-103	CAB-102-105	CAB-106-102
3/8	1/2	CAB-101-104	CAB-102-106	CAB-106-103
1/2	5/8	CAB-101-106	CAB-102-107	CAB-106-105

* Minimum Order 25 Pieces

Stainless Steel Braid Slewing



Used to protect lead wire against abrasion or physical damage in hazardous environments.

Order by the foot: 50 ft. minimum

I.D. (in)	Part Number
.078	CAB-105-101
.125	CAB-105-102
.172	CAB-105-103
.250	CAB-105-104
.375	CAB-105-105

All Items Available from Stock

Stock Quick-Disconnect High Temperature Electrical Plugs

Quick-Disconnect High Temperature Plugs provide the simplest and safest way to apply power to heater installations. The combination of plug and cup assembly along with armor cable covered leads eliminates all live exposed terminals or wiring that can be a potential hazard to employees or machines.

- * *Replace Exposed Terminals*
- * *Durable Cast Aluminum Body*
- * *High Temperature Ceramic Insulators*
- * *Solid Brass Contacts*
- * *Replace Exposed Lead Wires*
- * *Temperature Exposure Up to 300°C (572°F)*
- * *Available on Many Tempco Heater Products*

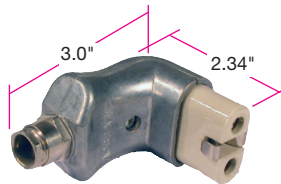

Right-Angle Plug

Electrical Rating: 25 Amp – 380 Volt
Part Number: EHD-101-103



Straight Plug

Electrical Rating: 25 Amp – 380 Volt
Part Number: EHD-101-102

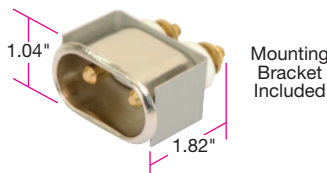

16 Amp Cup Assembly

Electrical Rating: 10 Amp – 250VDC
16 Amp – 250VAC
Cutout size: 1.495" x .790"
Part Number: EHDR-1001

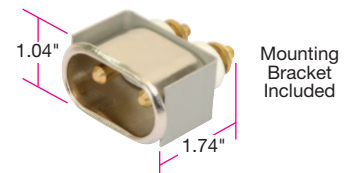

25 Amp Cup Assembly

Electrical Rating: 25 Amp – 400 Volt
Cutout size: 1.495" x .790"
Part Number: EHDR-1231



Plugs can be prewired and fitted with armor cable or wire braid leads.

Part Number: assigned when ordered

Heavy Duty Quick-Disconnect Plugs and Matching Connectors (Cable Type)

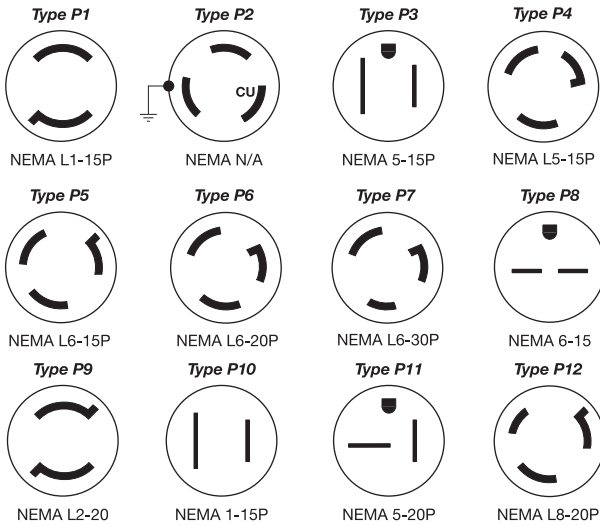
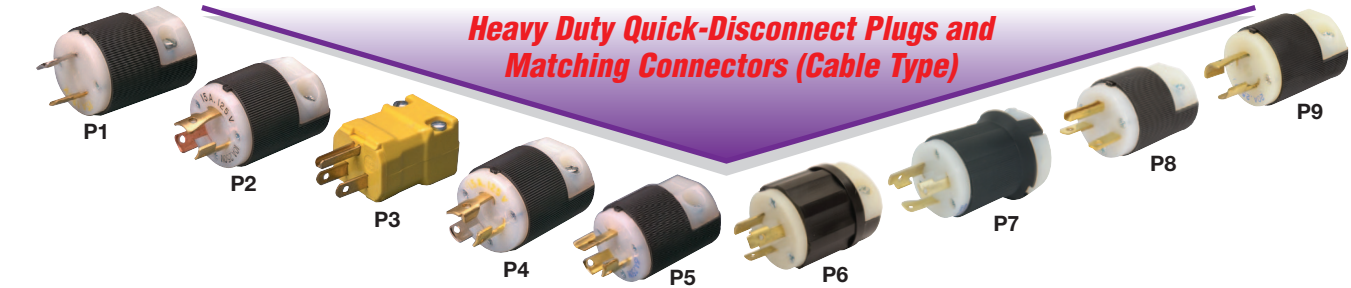

Reference	NEMA P or R	Amps	Volts	Plug Part No.	Connectors (Female) Part Number
P1 twist lock	L1-15	15A	125V	EHD-102-102	EHD-103-101
P2 twist lock	N/A	10A 15A	250V 125V	EHD-102-107	EHD-103-103
P3 straight	5-15	15A	125V	EHD-102-103	EHD-103-102
P4 twist lock	L5-15	15A	125V	EHD-102-113	EHD-103-104
P5 twist lock	L6-15	15A	250V	EHD-102-121	EHD-103-107
P6 twist lock	L6-20	20A	250V	EHD-102-122	EHD-103-150
P7 twist lock	L6-30	30A	250V	EHD-102-126	EHD-103-125
P8 straight	6-15	15	250V	EHD-102-114	EHD-103-139
P9 twist lock	L2-20	20A	250V	EHD-102-104	N/A
P10 straight	1-15	15	125V	EHD-102-101	N/A
P11 straight	5-20	20	125V	EHD-102-140	N/A
P12 straight	L8-20	20	480V	EHD-102-123	EHD-103-106



Notes: Type P2 twist lock plug is not listed by UL, and is recommended for replacement use only in existing installations. Connectors are cable mount only.

General Purpose Terminal Boxes (Can be field retrofit or factory installed)

Housings that Fit – Mica Bands, Ceramic Bands, Mi-Plus® Bands and Mica Strip Heaters

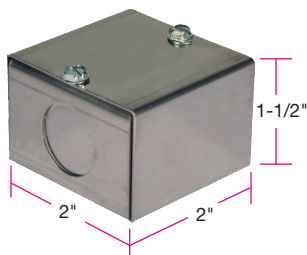

For use on **Std. T3 Screw Termination with 10-32 studs.**
Terminal mounting centers: 7/8"
Two Knockouts:
1/2" conduit, One on each side
Part Number: HSGR-1149

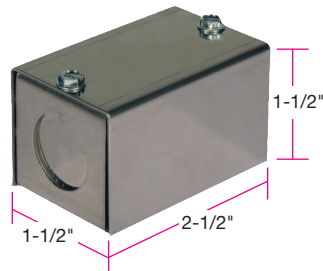

For use on **Std. T2 Screw Termination with 10-32 studs.**
Terminal mounting centers: 7/8"
Two Knockouts:
1/2" conduit, One on each side
Part Number: HSGR-1013

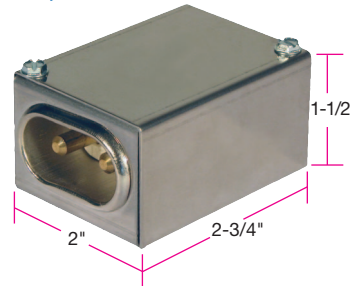

Box HSGR-1005 w/ EHDR-1001 cup assembly (see pg. 15-14).
For use on **Std. T3 Screw Termination with 10-32 studs.**
Terminal mounting centers: 7/8"
Part Number: EHDR-1002

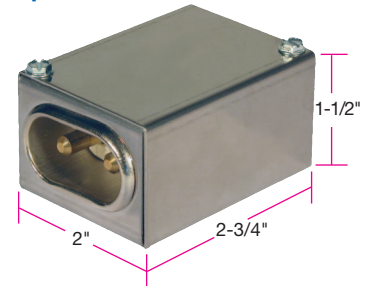

Box HSGR-1227 w/ EHDR-1231 cup assembly (see pg. 15-14).
For use on **Std. T3 Screw Termination with 10-32 studs.**
Terminal mounting centers: 7/8"
Part Number: EHDR-1005

Housings that Fit – Channel Strip and Finned Channel Strip Heaters

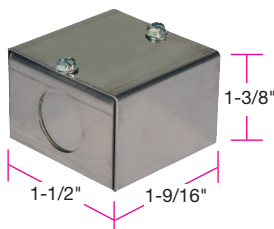

For use on **Standard T3 Screw Termination with 10-32 studs.**
Terminal mounting centers: 3/4"
One Knockout:
1/2" conduit, One as shown
Part Number: HSGR-1008

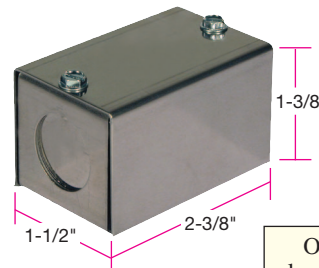

For use on **Standard T2 Screw Termination with 10-32 studs.**
Terminal mounting centers: 3/4"
Two Knockouts:
1/2" conduit, One on each side
Part Number: HSGR-1068

Other style boxes such as PVC, drawn aluminum or, explosion-proof are available.

Insulation Blankets

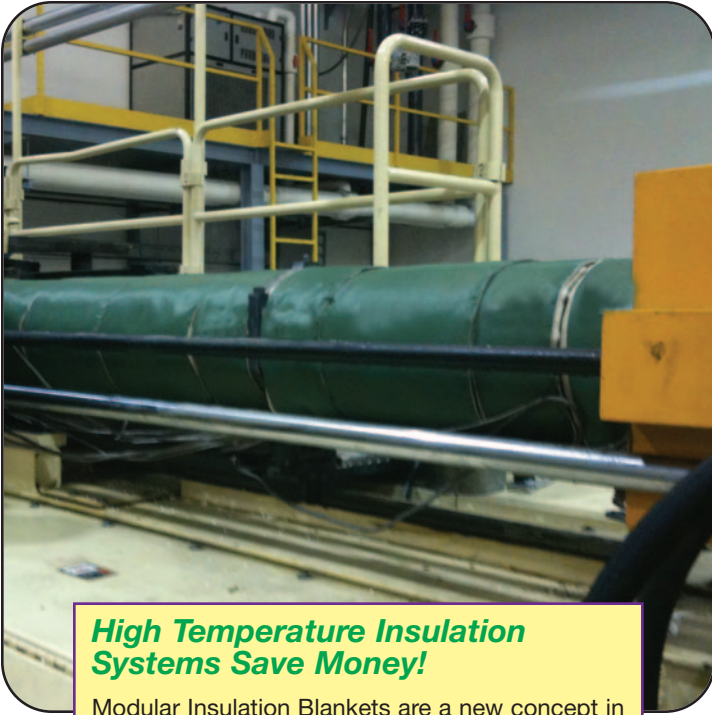

High Temperature Insulation Systems Save Money!

Modular Insulation Blankets are a new concept in insulation systems that will allow you to insulate most typical plastic molding machines with ease.

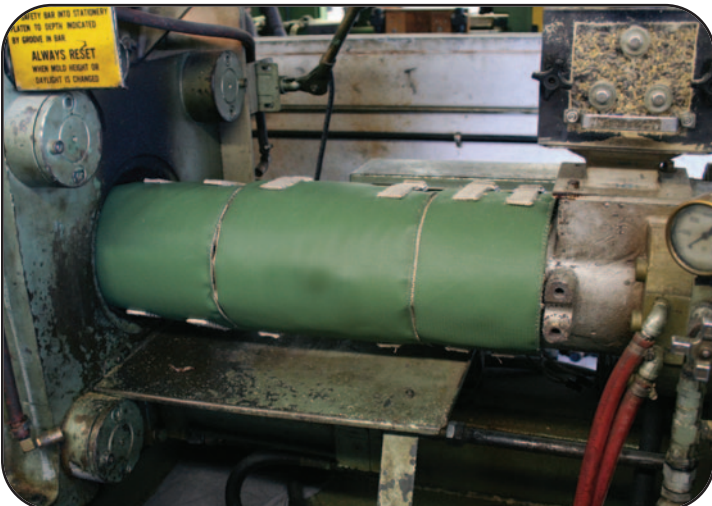
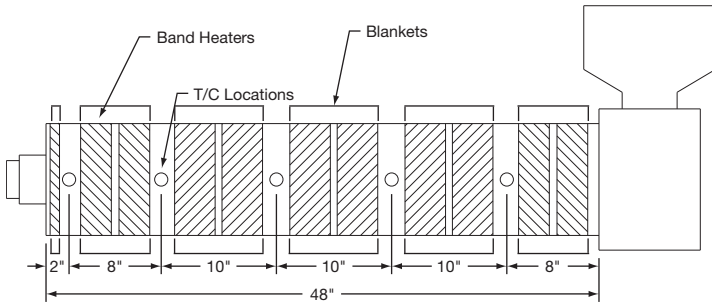

Tempco offers a line of Modular Insulating Blankets designed to contain the heat generated by industrial elements in various applications, thereby conserving energy and cooling the environment.

Simply measure the outside diameter of your heater bands and the width between thermocouples. The distance between thermocouples is critical because the modular blankets should be sized to fit between them. To insulate an 8" width, you would utilize two blankets, for instance, a 2" and 6" wide blanket.

Example (refer to the drawing)

- The length of the plastic injection machine barrel to insulate is 48".
- From the hopper end, the thermocouple breaks needed are at 8", 18", 28", 38", 46" and 48". This would yield insulation distances of 8", 10", 10", 10", 8", and 2" between the thermocouples. For the (two) 8" distances, use two 4" blankets each. For the (three) 10" distances use one 4" and one 6" blanket each. For the 2" distance, use one 2" blanket.

To summarize, the total requirement is: one 2" blanket seven 4" blankets three 6" blankets

Typical Applications

- Injection Molding
- Extrusion Barrels and Blow Molding
- Pre-Heaters
- Hoppers and Driers
- Hot Oil Lines
- Manifolds
- Melt Pipe Dies and Adapters

SPECIFICATIONS

- Hot Face/Inside Fabric**
 - Material:** Silica Fabric with Vermiculite
 - Thickness:** .042"
 - Maximum Temperature:** 1800°F (982°C) continuous
- Cold Face/Outside Fabric**
 - Material:** PTFE-Impregnated Fiberglass Cloth
 - Thickness:** .014"
 - Maximum Temperature:** 550°F (288°C) continuous

- Insulation**
 - Material:** Ceramic Fiber
 - Thickness:** 1"
 - Maximum Temperature:** 2300°F (1260°C)

- Straps**
 - Material:** PTFE-Impregnated Fiberglass Cloth

- Buckles**
 - Material:** Nickel-Plated steel wire with loose roller to allow for ease of tightening of straps

Note: When using insulation blankets it is recommended to derate the wattage of the heater bands by 20 to 25% to extend heater life and further reduce power consumption.

Energy Savings Using Insulation Blankets

Injection Molding Barrel Estimated Return on Investment

Estimated Initial Tonnage	Avg. KWh Investment	Avg. KWh Uninsulated	Payback Insulated	Estimated 3 Year Period - months	Savings
150	\$300	1.52	0.52	8.54	\$1,391.81
300	660	3.00	2.05	10.69	2,223.72
500	1,100	7.65	6.02	10.38	3,815.28
850	1,870	9.33	6.79	11.32	5,945.04
1000	2,200	11.35	8.12	10.48	7,560.00
1500	3,300	13.54	9.22	11.75	10,111.32

NOTE: The above information is to be used for comparisons only. Actual results in your plant on your injection molding machines may differ.



Standard (Non-Stock) Insulation Blankets

Inner Diameter	Width	Part Number	
		With 1" Overlap Flap	Without Overlap Flap
4"	2"	BLK00402	BLK10402
	4"	BLK00404	BLK10404
	6"	BLK00406	BLK10406
5"	2"	BLK00502	BLK10502
	4"	BLK00504	BLK10504
	6"	BLK00506	BLK10506
6"	2"	BLK00602	BLK10602
	4"	BLK00604	BLK10604
	6"	BLK00606	BLK10606
7"	2"	BLK00702	BLK10702
	4"	BLK00704	BLK10704
	6"	BLK00706	BLK10706
8"	2"	BLK00802	BLK10802
	4"	BLK00804	BLK10804
	6"	BLK00806	BLK10806
9"	2"	BLK00902	BLK10902
	4"	BLK00904	BLK10904
	6"	BLK00906	BLK10906
10"	2"	BLK01002	BLK11002
	4"	BLK01004	BLK11004
	6"	BLK01006	BLK11006
11"	2"	BLK01102	BLK11102
	4"	BLK01104	BLK11104
	6"	BLK01106	BLK11106
12"	2"	BLK01202	BLK11202
	4"	BLK01204	BLK11204
	6"	BLK01206	BLK11206

Ordering Information

Standard — After determining the diameter and width of the insulation blankets required, select the **Part Number** from the chart above that matches your requirements.

Custom Engineered/Manufactured — Custom Insulation Blankets can also be designed for your application in circumferential or flat applications. Please submit to Tempco your drawing or sketch to quote.

Standard lead time is Stock to 4 weeks.

⚠ WARNING: Cancer and Reproductive Harm - www.P65Warnings.ca.gov.

Heater Accessories

Heater Accessories (Stock)



High Temperature Terminal Lugs

Order by the piece: 25 pc. minimum

Terminal Type	Screw Size	Wire Size Ga.	Temperature °F/°C	Part Number
Ring	#12	16-14	1200/649	TER-111-101
	#10	22-18	900/482	TER-110-117
	#10	16-14	1200/649	TER-110-104
	#10	16-14	900/482	TER-110-106
	#10	12-10	900/482	TER-110-111
	#8	22-18	900/482	TER-109-110
	#8	16-14	1200/649	TER-109-101
	#8	16-14	900/482	TER-109-104
Spade	#8	12-10	900/482	TER-109-106
	#10	22-18	900/482	TER-115-111
	#8/10	22-18	900/482	TER-115-112
	#8	16-14	900/482	TER-115-113

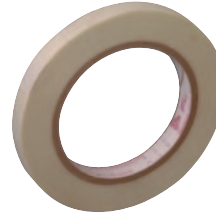

Fiberglass Tape

A superior pressure-sensitive adhesive tape consisting of fiberglass cloth impregnated with a thermosetting silicone.

Thickness: .007" **Length:** 36 yards
Maximum Temperature: 356°F (180°C)

Width	Part Number
1/2"	TAP-101-101
1/4"	TAP-101-102

Irreversible Temperature Strips and Indicators

SPECIFICATIONS

Material: Polyester for up to 160°C/320°F
Polyimide for above 160°C/320°F

Accuracy: ± 1°C below 100°C/212°F
± 1% above 100°C/212°F

Pressure-Sensitive Adhesive:
Double sided low tack adhesive up to 160°C/320°F

Label Color: Black printing on blue background

Temperature Reached:
Indicated in change from white to black

5-Point "Clock" Multipoint Indicators

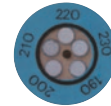

Size: 0.5" x 0.5"

Temperature Point (°F)	Part Number
140, 150, 160, 170, 180	NTS20180
190, 200, 210, 220, 230	NTS20230
240, 250, 261, 270, 280	NTS20280
290, 300, 310, 320, 330	NTS20330
340, 350, 360, 370, 380	NTS20380
390, 400, 410, 420, 435	NTS20435
450, 466, 480, 490, 500	NTS20500

NOTE: Ordered in packs of 10 temperature clock labels per pack.

Single Point Indicators



Size: 0.5" x 0.5"

Temperature Point °F	Temperature Point °C	Part Number
129	54	NTS30129
149	65	NTS30149
160	71	NTS30160
171	77	NTS30171
180	82	NTS30180
199	93	NTS30199
219	104	NTS30219
230	110	NTS30230
241	116	NTS30241
250	121	NTS30250
261	127	NTS30261
270	132	NTS30270
280	138	NTS30280
289	143	NTS30289
300	149	NTS30300

NOTE: Ordered in packs of 50 temperature indicators per pack.

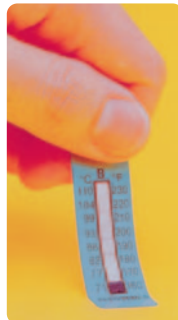

Size: 2" x 0.7"

Multi-Level Strip Indicators

Stock Items Are Shown In **RED**

Type	Temperature Points	Part Number
8 Level	°F: 100, 105, 110, 115, 120, 130, 140, 150 °C: 37, 40, 43, 46, 49, 54, 60, 65	NTS10150
8 Level	°F: 160, 170, 180, 190, 200, 210, 220, 230 °C: 71, 77, 82, 88, 93, 99, 104, 110	NTS10230
8 Level	°F: 240, 250, 260, 270, 280, 290, 300, 310 °C: 116, 121, 127, 132, 138, 143, 149, 154	NTS10310
8 Level	°F: 320, 330, 340, 350, 360, 370, 380, 390 °C: 160, 166, 171, 177, 182, 188, 193, 199	NTS10390
9 Level	°F: 400, 410, 420, 435, 450, 465, 480, 490, 500 °C: 204, 210, 216, 224, 232, 241, 249, 254, 260	NTS10500
5 Level	°F: 480, 490, 500, 536, 554 °C: 249, 254, 260, 280, 290	NTS10554

NOTE: Ordered in packs of 10 temperature strips per pack.

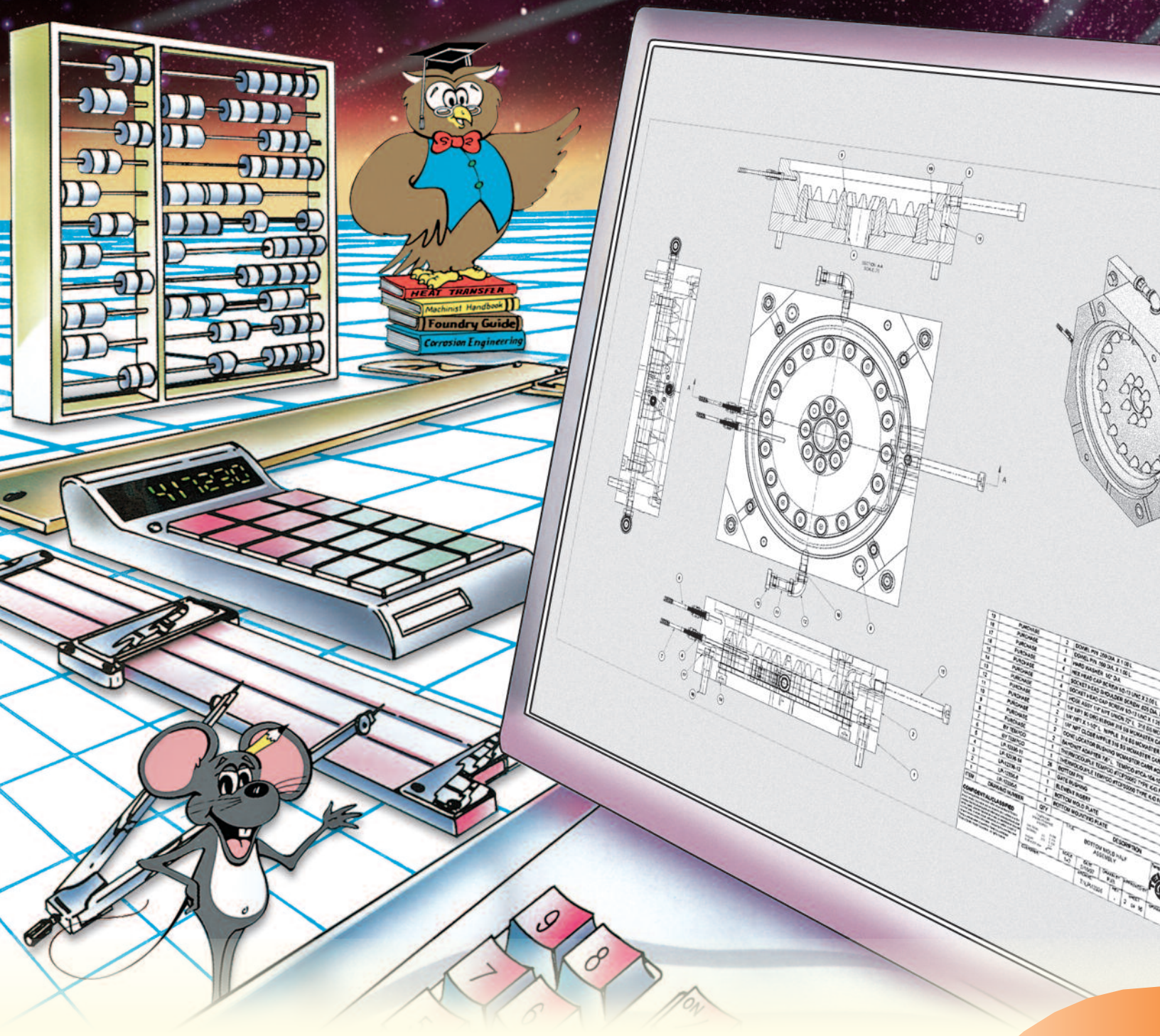

Table Of Contents

Heat Requirement Calculations.....	16-2	Electrical Formulas/Diagrams	16-9
Properties of Materials.....	16-4	Sheath Material Selection Guide.....	16-12
Wattage Estimation Tables.....	16-5	Conversion Factors.....	16-21
Formulas for Liquids and Gases	16-6	Area and Volume Formulas	16-22
Temperature Conversion Table	16-8	Decimal/Millimeter Equivalents	16-23

16

section

Heat Requirement Calculations

There are two basic heat energy requirements to be considered in the sizing of heaters for a particular application:

1. Start-Up Heat is the heat energy required to bring a process up to operating temperature. Start-up heat requirement calculations which include a material change of state should be calculated in three parts:

- 1) Heat requirement from ambient temperature to change of state temperature
- 2) Heat requirement during change of state (latent heat)
- 3) Heat requirement from change of state temperature to operating temperature

2. Operating Heat is the heat energy required to maintain the desired operating temperature through normal work cycles. The larger of these two heat energy values will be the wattage required for the application.

A safety factor is usually added to allow for unknown or unexpected operating conditions. The safety factor is dependent on the accuracy of the wattage calculation. A figure of 10% is adequate for small systems closely calculated, while 20% additional wattage is more common, and figures of 25% to 35% should be considered for larger systems with many unknown conditions existing.

Start-Up Heat requirements will include one or more of the following calculations, depending on the application:

1. Wattage required to heat material:

$$\frac{\text{Weight of material (lbs)} \times \text{Specific Heat (Btu/lb } ^\circ\text{F)} \times \text{Temperature rise (} ^\circ\text{F)}}{3.412 \text{ btu/watt hr.} \times \text{Heat-up time (hr.)}} = \text{Watts}$$



See page 16-4 for Properties of Materials

2. Wattage required to heat container or tank:

$$\frac{\text{Weight of container (lbs)} \times \text{Specific Heat (Btu/lb } ^\circ\text{F)} \times \text{Temperature rise (} ^\circ\text{F)}}{3.412 \text{ btu/watt hr.} \times \text{Heat-up time (hr.)}} = \text{Watts}$$

3. Wattage required to heat hardware in container:

$$\frac{\text{Weight of hardware (lbs)} \times \text{Specific Heat (Btu/lb } ^\circ\text{F)} \times \text{Temperature rise (} ^\circ\text{F)}}{3.412 \text{ btu/watt hr.} \times \text{Heat-up time (hr.)}} = \text{Watts}$$

4. Wattage required to melt a solid to a liquid at constant temperature:

$$\frac{\text{Heat of fusion (Btu/lb)} \times \text{Weight of material to be melted (lb/hr)}}{3.412 \text{ btu/watt hr.}} = \text{Watts}$$

Heat of Fusion (Latent Heat): The amount of heat required to change one pound of a given substance from solid to liquid state without change in temperature is termed the heat of fusion. It requires 144 Btu to change one pound of ice at 32°F to one

pound of water at 32°F, thus the heat of fusion of ice is 144 Btu per pound.

A change of state is usually accompanied by a change of specific heat. The specific heat of ice is 0.5; while that of water is 1.0.

5. Wattage required to change a liquid to a vapor state at constant temperature:

$$\frac{\text{Heat of vaporization (Btu/lb)} \times \text{Weight of material to be vaporized (lb/hr)}}{3.412 \text{ btu/watt hr.}} = \text{Watts}$$

Heat of Vaporization (Latent Heat): The amount of heat required to change one pound of a given substance from liquid to vapor state without change in temperature is termed the heat

of vaporization.

It requires 965 Btu to change one pound of water at 212°F to one pound of steam at 212°F.

6. Wattage to counteract liquid surface losses: See Graph 3 on opposite page for loss rates of water and oils.

$$\frac{\text{Total liquid surface area (sq. ft.)} \times \text{Loss rate at final temperature (watts/sq. ft.)}}{2} = \text{Watts}$$

7. Wattage to counteract surface losses from container walls, platen surfaces, etc.: See Graph 2 on opposite page for losses from metal surfaces. See Graph 1 for losses from insulated surfaces.

$$\frac{\text{Total surface area (sq. ft.)} \times \text{Loss rate at final temperature (watts/sq. ft.)}}{2} = \text{Watts}$$

Heat Requirement Calculations

Operating heat requirements will include one or more of the following calculations. Any additional losses particular to the application should also be estimated and included.

- 1. Wattage to counteract losses from open liquid surfaces:** See Graph 3 for loss rates of water and oils.

Total liquid surface area (sq. ft.) × Loss rate at operating temperature (watts/sq. ft.) = Watts

- 2. Wattage to counteract container or platen surface losses,** either insulated (See Graph 1) or uninsulated (See Graph 2).

Total surface area (sq. ft.) × Loss rate at operating temperature (watts/sq. ft.) = Watts

- 3. Wattage required to heat material transferred in and out of the system.**

(Metal dipped in heated tanks, air flows, make-up liquids, etc.)

$$\frac{\text{Weight of material to be heated (lbs)} \times \text{Specific Heat (Btu/lb } ^\circ\text{F)} \times \text{Temperature rise (} ^\circ\text{F)}}{3.412 \text{ btu/watt hr.} \times \text{Heat-up time (hr.)}} = \text{Watts}$$

- 4. Heat-up of racks of containers, etc. transferred in and out of the system:**

$$\frac{\text{Weight of items to be heated (lbs)} \times \text{Specific Heat (Btu/lb } ^\circ\text{F)} \times \text{Temperature rise (} ^\circ\text{F)}}{3.412 \text{ btu/watt hr.} \times \text{Heat-up time (hr.)}} = \text{Watts}$$

Specific Heat: The heat necessary to increase the temperature of all other substances has been referred to water as a standard. The ratio of the amount of heat required to increase the temperature of

one pound of any substance by one degree to the amount necessary to increase one pound of water is known as the specific heat of that substance.

Heat Loss Information

Graph 1 Heat Losses through Insulated Walls (based on standard thermal insulations)

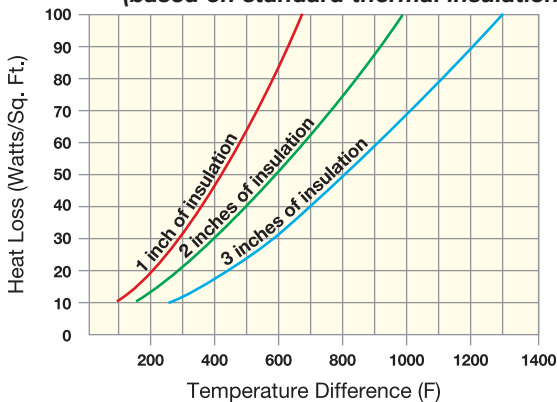

Figures are for vertical surfaces.
Multiply by 120% for a horizontal top surface and by 60% for a horizontal bottom surface.

Graph 2 Heat Losses from Uninsulated Metal Surfaces

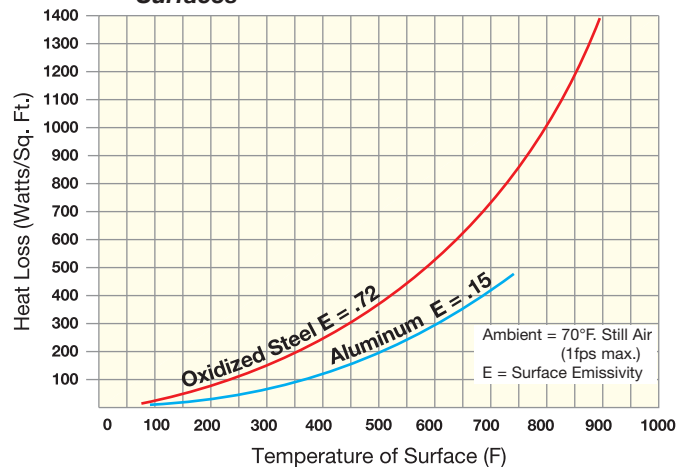

Graph 3 Heat Losses from the Surface of Water and Oil

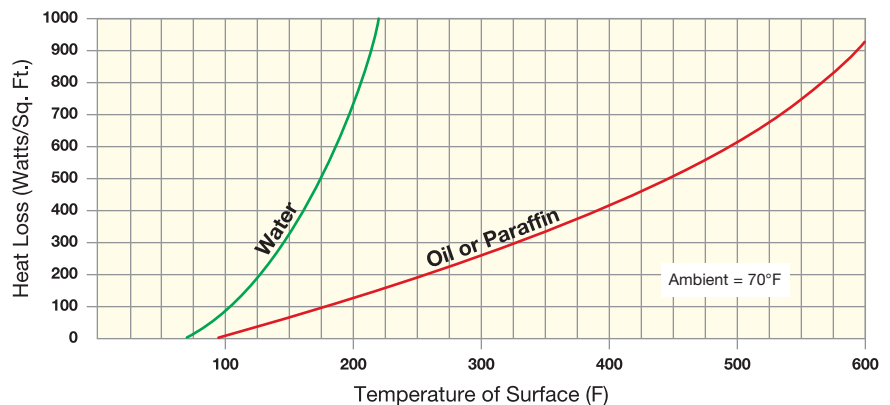

Properties of Materials

Properties of Metals

Material	*Density lb./in ³	Specific Heat Btu (lb) (°F)	*Thermal Conductivity (Btu) (in.) (hr.) (ft ²) (°F)	Melting Point °F (Lowest)	Latent Heat of Fusion Btu/lb.	*Thermal Expansion in/in/°F × 10 ⁻⁶
Aluminum 1100-0	.098	.24	1540	1190	169.0	13.1
Brass, Yellow	.306	.096	816	1710		11.3
Copper	.324	.095	2736	1981	91.1	9.2
Gold	.698	.032	2064	1945	29.0	7.9
Incoloy® 800	.290	.13	80	2500		7.9
Inconel® 600	.304	.13	103	2500		5.8
Invar 36% Ni	.289	.12	76	2600		0.6
Iron, Malleable Cast	.260	.11	320	2250		6.0
Lead, Solid	.410	.032	241	621	11.3	16.3
Lead, Liquid	.372	.037	107			
Magnesium	.063	.25	1068	1202	160.0	14.0
Molybdenum	.369	.071	980	4750	126.0	2.94
Monel 400	.319	.11	151	2400		6.4
Nickel 200	.321	.12	520	2615	133.0	5.8
Nichrome (80% Ni-20% Cr)	.302	.11	104	2550		7.3
Palladium 99.5%	.432	.06	490	2830	69.5	6.5
Platinum	.775	.035	480	3217	49.0	4.9
Silver	.379	.057	2904	1761	38.0	11.4
Solder (50% Pb-50% Sn)	.321	.051	323	421	17	13.0
Steel, Mild	.284	.12	460	2760		6.7
Steel, Stainless 304	.290	.12	113	2550		9.6
Steel, Stainless 430	.280	.11	181	2600		5.8
Tantalum	.600	.035	372	5425		3.57
Tin, Solid	.264	.065	468	449	26.1	12.8
Tin, Liquid	.246	.052	228			
Titanium 99.0%	.163	.13	112	3020	187	4.8
Tungsten	.697	.03	1140	6170	79.0	2.45
Type Metal (85% Pb-15% Sn)	.387	.04		500	14	
Zinc	.258	.096	785	787	43.3	22.0
Zirconium	.234	.067	145	3350	108	3.22

Properties of Non-Metallic Solids

Asphalt	.076	.22	5.16	250	40	
Boron Nitride (Compacted)	.082	.33	125.00	5430		1-4
Brick, Hard	.072	.24	9.00			3-6
Carbon	.080	.20	165.00	6700		0.3-2.4
Cellulose Acetate	.048	.40	1.20-2.30			61-83
Delrin	.050	.35	1.56			45
Glass, Crown	.101	.16	7.50			5
Ice	.033	.49	15.60	32	144	28.3
Mica	.098	.12	4.80			18
MgO (Compacted)	.110	.21	14.40			7.7
Nylon	.042	.45	1.70			61-63
Paper	.033	.33	0.84			
Paraffin	.033	.69	1.60	133	63	
Phenolic (Cast Resin)	.047	.35	1.1			44-61
Polyethylene (High Density)	.035	.55	3.36			94
Polystyrene	.038	.32	0.70-1.00			33-44
Rubber, Hard	.043	.48	1.12			340
Steatite	.073	.20	20.40			4.5-5.5
Sulfur	.072	.20	1.80	230	17	
Teflon	.078	.25	1.70			55
Vinylidene	.062	.32	2.00			28-100
Wood, Oak	.027	.57	1.22			

Properties of Liquids

Liquid	*Density lb./Gal.	Specific Heat Btu (lb) (°F)	*Thermal Conductivity (Btu) (in.) (hr.) (ft ²) (°F)	Boiling Point °F	Heat of Vaporization Btu/lb.
Acetic Acid, 20%**	8.60	.91	3.70	214±	810±
Alcohol (ethyl)	6.74	.60	1.30	173	367
Brine (25% NaCl)**	9.91	.79	2.88	220±	730±
Caustic Soda (18% NaOH)**	10.00	.84	3.90	221±	795±
Dowtherm A	8.80	.44	0.96	496	42.2
Ethylene Glycol	9.36	.56		387	
Freon 12	10.94	.23	0.49	-21.6	62
Glycerine	10.52	.58	1.97	556	
Hydrochloric Acid 10%**	8.89	.93	3.90	221	
Nitric Acid, 7%**	8.65	.92	3.80	220±	918±
Oils (Petroleum)	7.35	.45			
Paraffin (melted)	7.49	.69±	1.68	572	70
Potassium (K)***	5.96	.18	253.20	1400	893
Sodium (Na)***	6.84	.30	446.40	1638	1810
Sulfuric Acid 10%**	9.90	.92	4.00	216	
Therminol FR-2	12.10	.30	0.70	648±	
Turpentine	7.22	.42	0.90	319	133
Vegetable Oil	7.75	.43±	1.10		
Water	8.34	1.00	4.08	212	965



* At or near room temperature
 ** Percent concentration by weight in H₂O solution

*** At 1000°F
 ± Approximate

Properties of Gases

Gas	*Density lb./ft ³	Specific Heat Btu/(lb) (°F)	*Thermal Conductivity (Btu) (in.) (hr.) (ft ²) (°F)
Air at 80°F	.073	.240	.18
at 400°F	.046	.247	.27
Ammonia	.044	.523	.16
Argon	.102	.125	.12
Carbon Dioxide	.113	.199	.12
Carbon Monoxide	.072	.248	.18
Chlorine	.184	.115	.06
Helium	.011	1.250	1.10
Hydrogen	.0052	3.390	.13
Methane	.0447	.590	.21
Nitrogen	.072	.248	.19
Oxygen	.082	.218	.18
Sulphur Dioxide	.172	.152	.07

Air Density Table (lb./cu. ft.)

Temp °F	Specific Heat	Gauge Pressure						
		0	10	50	100	200	250	300
0	.240	.086	.145	.380	.674	1.261	1.555	1.848
10	.240	.085	.142	.372	.659	1.234	1.522	1.808
20	.240	.083	.139	.364	.646	1.208	1.490	1.771
30	.240	.081	.136	.357	.632	1.184	1.459	1.735
40	.240	.079	.133	.350	.620	1.160	1.430	1.700
50	.240	.078	.131	.343	.608	1.137	1.402	1.667
60	.240	.076	.128	.336	.596	1.115	1.375	1.635
70	.240	.075	.126	.330	.585	1.094	1.349	1.600
80	.240	.074	.124	.324	.574	1.074	1.324	1.574
90	.240	.072	.121	.318	.563	1.055	1.300	1.546
100	.240	.071	.119	.312	.553	1.036	1.277	1.518
120	.240	.068	.115	.301	.534	1.000	1.233	1.466
140	.240	.066	.111	.291	.516	.967	1.192	1.417
160	.241	.064	.108	.282	.500	.936	1.153	1.371
180	.241	.062	.104	.273	.484	.906	1.117	1.328
200	.242	.060	.101	.265	.470	.879	1.084	1.288
220	.242	.058	.098	.257	.456	.853	1.052	1.250
240	.242	.057	.095	.250	.443	.829	1.022	1.215
260	.243	.055	.093	.243	.430	.806	.993	1.181
280	.243	.054	.090	.236	.419	.784	.966	1.149
300	.244	.052	.088	.230	.408	.763	.941	1.119
320	.244	.051	.086	.224	.397	.744	.917	1.090
340	.244	.050	.083	.219	.387	.725	.894	1.063
360	.246	.048	.081	.213	.378	.707	.872	1.037
380	.246	.047	.079	.208	.369	.691	.851	1.012
400	.247	.046	.078	.203	.360	.674	.832	.989
420	.247	.045	.076	.199	.352	.659	.813	.966
440	.247	.044	.074	.194	.344	.644	.795	.945
460	.248	.043	.073	.190	.337	.630	.777	.924
480	.248	.042	.071	.186	.330	.617	.761	.905
500	.249	.041	.070	.182	.323	.604	.745	.886
520	.249	.041	.068	.178	.316	.592	.730	.868
540	.249	.040	.067	.175	.310	.580	.715	.850
560	.250	.039	.065	.171	.304	.569	.701	.834
580	.251	.038	.064	.168	.298	.558	.688	.818
600	.252	.037	.063	.165	.292	.547	.675	.802
620	.252	.037	.062	.162	.287	.537	.662	.787
640	.252	.036	.061	.159	.281	.527	.650	.773
660	.253	.035	.060	.156	.277	.518	.639	.759
680	.253	.035	.059	.153	.272	.509	.627	.746
700	.254	.034	.058	.151	.267	.500	.616	.733
720	.254	.034	.057	.148	.263	.492	.606	.721
740	.255	.033	.056	.146	.258	.483	.596	.709
760	.256	.033	.055	.143	.254	.475	.586	.697
780	.256	.032	.054	.141	.250	.468	.577	.686
800	.257	.032	.053	.139	.246	.460	.568	.675
820	.257	.031	.052	.137	.242	.453	.559	.664
840	.257	.031	.051	.134	.238	.446	.550	.654
860	.258	.030	.051	.132	.235	.439	.542	.644
880	.259	.030	.050	.130	.231	.433	.534	.634
900	.260	.029	.049	.129	.228	.427	.526	.625
920	.260	.029	.048	.127	.225	.420	.518	.616
940	.260	.028	.048	.125	.221	.414	.511	.607
960	.261	.028	.047	.123	.218	.408	.504	.599
980	.261	.028	.046	.121	.215	.403	.497	.590
1000	.262	.027	.046	.120	.212	.397	.490	.582
1020	.262	.027	.045	.118	.209	.392	.483	.574
1040	.263	.026	.044	.117	.207	.387	.477	.567
1060	.264	.026	.044	.115	.204	.382	.470	.559
1080	.264	.026	.043	.114	.201	.377	.464	.552
1100	.265	.025	.043	.112	.199	.372	.458	.545
1120	.265	.025	.042	.111	.196	.367	.453	.538
1140	.265	.025	.042	.108	.194	.363	.447	.531
1160	.266	.025	.041	.108	.191	.358	.441	.525
1180	.266	.024	.041	.107	.189	.354	.436	.518
1200	.267	.024	.040	.105	.187	.349	.431	.512

Kilowatt Hours to Heat Water

Amount of Water		Temperature Rise (°F)							
Cubic Feet	Gallons	20	40	60	80	100	120	140	
		Kilowatts to heat in one hour							
0.67	5	0.3	0.5	0.8	1.1	1.3	1.6	1.9	
1.3	10	0.5	1.1	1.6	2.2	2.7	3.2	3.8	
2.0	15	0.8	1.6	2.4	3.2	4.0	4.8	5.6	
2.7	20	1.1	2.2	3.2	4.3	5.4	6.5	7.5	
3.3	25	1.3	2.7	4	5.4	6.7	8.1	9.4	
4.0	30	1.6	3.2	4.8	6.5	8.1	9.7	11.3	
5.3	40	2.2	4.3	6.5	8.6	10.8	12.9	15.1	
6.7	50	2.7	5.4	8.1	10.8	13.5	16.1	18.8	
8.0	60	3.2	6.5	9.7	12.9	16.1	19.4	22.6	
9.4	70	3.8	7.5	11.3	15.1	18.8	22.6	26.4	
10.7	80	4.3	8.6	12.9	17.2	21.5	25.8	30.1	
12.0	90	4.8	9.7	14.5	19.4	24.2	29.1	33.9	
13.4	100	5.4	10.8	16.1	21.5	26.9	32.3	37.7	
16.7	125	6.7	13.5	20.2	26.9	33.6	40.4	47.1	
20.1	150	8.1	16.1	24.2	32.3	40.4	48.4	56.5	
23.4	175	9.4	18.8	28.2	37.7	47.1	56.5	65.9	
26.7	200	10.8	21.5	32.3	43	53.8	64.6	75.3	
33.4	250	13.5	26.9	40.4	53.8	67.3	80.7	94.2	
40.1	300	16.1	32.3	48.4	64.6	80.7	96.9	113.0	
53.5	400	21.5	43.0	64.6	86.1	107.6	129.1	150.7	
66.8	500	26.9	53.8	80.7	107.6	134.5	161.4	188.3	

Kilowatt Hours to Heat Oil

Amount of Oil		Temperature Rise (°F)						
Cubic Feet	Gallons	50	100	200	300	400	500	
		Kilowatts to Heat in One Hour						
0.67	5	0.3	0.7	1.4	2.09	2.79	3.49	
1.3	10	0.7	1.4	2.8	4.19	5.58	6.98	
2.0	15	1	2.1	4.2	6.28	8.37	10.5	
2.7	20	1.4	2.8	5.6	8.37	11.2	14	
3.3	25	1.7	3.5	7	10.5	14	17.4	
4.0	30	2.1	4.2	8.4	12.6	16.7	20.9	
5.3	40	2.8	5.6	11	16.7	22.3	27.9	
6.7	50	3.5	7	14	20.9	27.9	34.9	
8.0	60	4.2	8.4	17	25.1	33.5	41.9	
9.4	70	4.9	9.8	20	29.3	39.1	48.8	
10.7	80	5.6	11	22	33.5	44.7	55.8	
12.0	90	6.3	13	25	37.7	50.2	62.8	
13.4	100	7	14	28	41.9	55.8	69.8	
16.7	125	8.7	17	35	52.3	69.8	87.2	
20.1	150	10	21	42	62.8	83.7	105	
23.4	175	12	24	49	73.3	97.7	122	
26.7	200	14	28	56	83.7	112	140	
33.4	250	17	35	70	105	140	174	
40.1	300	21	42	84	126	167	209	
53.5	400	28	56	112	167	223	279	
66.8	500	35	70	140	209	279	349	

For Water:

Use Equation 1 for heating flowing water.

Use Equation 2 or the table for heating water in tanks.

Equation 1

$$KW = GPM \times \text{Temperature Rise } (^\circ F) \times .16$$

Equation 2

$$KW = \frac{\text{Gallons} \times \text{Temperature Rise } (^\circ F)}{372 \times \text{Heat-up time (hrs.)}}$$

NOTE: 10% safety factor is included.

For Oil:

Use equation or table

$$KW = \frac{\text{Gallons} \times \text{Temperature Rise } (^\circ F)}{860 \times \text{Heat-up time (hrs.)}}$$

NOTE: The above KW values are based on an average specific heat of 0.45 (btu/lb/°F) and a Density of 7.35 lb/gallon plus a 20% safety factor. This table should be used only as a guide; exact wattage requirements can be calculated using the formulas on pages 16-2 and 16-6.

Kilowatts to Heat Air

For free air:

Use equation or table

$$KW = \frac{\text{SCFM} \times \text{Temperature Rise } (^\circ F)}{3000}$$

Use the maximum anticipated airflow. This equation assumes insulated duct (negligible heat loss) and 70°F inlet air at 14.7 PSIA.

For compressed air:

$$KW = \frac{\text{CFM}^* \times \text{Density}^*(\text{lbs/cu. ft.}) \times \text{Temperature rise } (^\circ F)}{228}$$

*At heater inlet temperature and pressure

Amt. of Air SCFM	Temperature Rise (°F)										
	50	100	150	200	250	300	350	400	450	500	600
100	1.7	3.3	5	6.7	8.3	10	11.7	13.3	15	16.7	20
200	3.3	6.7	10	13.3	16.7	20	23.3	26.7	30	33.3	40
300	5	10	15	20	25	30	35	40	45	50	60
400	6.7	13.3	20	26.7	33.3	40	46.7	53.3	60	66.7	80
500	8.3	16.7	25	33.3	41.7	50	58.3	66.7	75	83.3	100
600	10	20	30	40	50	60	70	80	90	100	120
700	11.7	23.3	35	46.7	58.3	70	81.7	93.3	105	116.7	140
800	13.3	26.7	40	53.3	66.7	80	93.3	106.7	120	133.3	160
900	15	30	45	60	75	90	105	120	135	150	180
1000	16.7	33.3	50	66.7	83.3	100	116.7	133.3	150	166.7	200
1100	18.3	36.7	55	73.3	91.7	110	128.3	146.7	165	183.3	220
1200	20	40	60	80	100	120	140	160	180	200	240

NOTE: If air flow is given in CFM at operating temperature and pressure it can be converted to SCFM (Standard Cubic Feet per Minute) with the following formula:

$$\text{SCFM} = \text{CFM} \times \frac{\text{PSIG} + 14.7}{T + 460} \times 35.37$$

PSIG = operating pressure (gauge pressure in lbs/sq.in.)

T = operating temperature in °F

SCFM = flow rate in CFM at standard conditions of 60°F and 14.7 PSIA.

KW Calculations

Calculating KW Requirements for Heating Liquids and Gases

When calculating the required KW, always use the maximum flow of the medium to be heated, the minimum temperature at the heater inlet, and the maximum desired outlet temperature. Also include a 20% Safety Factor to allow for heat losses to jacket and piping, voltage variation and wattage tolerance.

For specific heat and density values see Properties of Materials Tables on page 16-4.

Safe element watt density and sheath material charts are located on pages 16-12 through 16-20.

Formula for Heating Liquids

$$KW = \frac{\text{Flow} \times 60 \text{ minute/hour} \times \text{Density} \times \text{Specific heat} \times \Delta T \times \text{Safety factor}}{3412 \text{ BTU/KWH}}$$

Flow = Flow in gallons/minute

Density = Density of liquid in pounds/gallon

Specific Heat = Specific heat of liquid in BTU/pound °F

ΔT = Temperature rise in °F

Sample problem for heating water:

Calculate KW required to heat 5 gallons/minute of water from 50 to 100°F.

$$KW = \frac{5 \text{ gal/min} \times 60 \text{ min/hr} \times 8.34 \text{ lb/gal} \times 1.0 \text{ BTU/lb}^\circ\text{F} \times 50^\circ\text{F} \times 1.2}{3412 \text{ BTU/KWH}}$$

Total KW required = 44

Water Flow Chart for Tempco 3" and 5" Flanged Circulation Heaters

Maximum water flow per hour through selected heaters at specified temperature rise.

Part Number	KW	20°F	30°F	40°F	50°F	60°F	70°F	80°F	90°F	100°F	110°F	120°F	130°F
CHF01891	6	123	82	61	49	41	35	31	27	25	22	20	19
CHF01895	9	184	123	92	74	61	53	46	41	37	33	31	28
CHF01898	12	245	164	123	98	82	70	61	55	49	45	41	38
CHF01901	15	307	205	153	123	102	88	77	68	61	56	51	47
CHF01904	18	368	245	184	147	123	105	92	82	74	67	61	57
CHF01928	24	491	327	245	196	164	140	123	109	98	89	82	76
CHF01931	30	614	409	307	245	205	175	153	136	123	112	102	94
CHF01934	36	736	491	368	295	245	210	184	164	147	134	123	113
CHF01935	50	1023	682	511	409	341	292	256	227	205	186	170	157
CHF01936	60	1227	818	614	491	409	351	307	273	245	223	205	189

$$(\text{Gallons}) \text{ HR} = \frac{(\text{KW}) (3412)}{(8.34) (\Delta T)}$$

NOTE: Safety factor not included. Add to suit application.

Formula for Heating Gases

$$KW = \frac{\text{Flow} \times 60 \text{ minute/hour} \times \text{Density} \times \text{Specific heat} \times \Delta T \times \text{Safety factor}}{3412 \text{ BTU/KWH}}$$

Flow = Flow in SCFM (standard cubic feet per minute measured at 14.7 PSIA and 70°F)

Density = Density of gas in pounds/cubic foot at standard conditions.

Specific Heat = Specific heat of gas in BTU/pound °F at standard conditions.

ΔT = Temperature rise in °F

NOTE: If air flow is given in CFM at operating temperature and pressure it can be converted to SCFM (Standard Cubic Feet per Minute) with the following formula:

$$\text{SCFM} = \text{CFM} \times \frac{\text{PSIG} + 14.7}{T + 460} \times 35.37$$

PSIG = operating pressure (gauge pressure in lbs/sq.in.)

T = operating temperature in °F

SCFM = flow rate in CFM at standard conditions of 60°F and 14.7 PSIA.

View Product Inventory @ www.tempco.com

Calculating KW Requirements to Superheat Steam

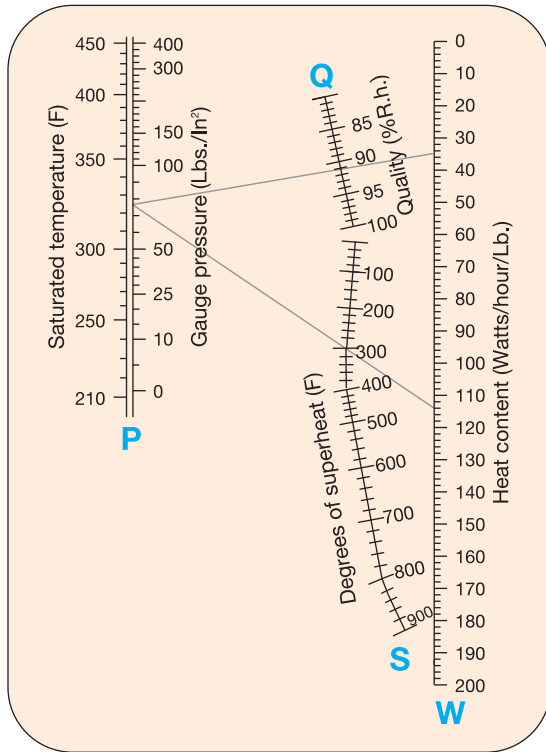

Superheated Steam Graph

Problem: Heat 420 lbs/hr of 90% quality steam to 620°F @ 75PSIG

- Plot the pressure on graph **P** and the steam quality on graph **Q**. Draw a straight line from **P** through **Q** and read **W1**.
- Plot the degrees of superheat on graph **S**. The degrees of superheat equals operating temperature minus saturated temperature. Saturated temperature is read beside gauge pressure on graph **P**.
620°F - 320°F = 300°F
Draw a straight line from **P** through **S** and read **W2**.
- Determine the required KW using the following equation:

$$\text{KW} = \text{LBS/HR} \times (\text{W2} - \text{W1}) / 1000 \times \text{Safety factor}$$

$$= 420 \times (114 - 36) / 1000 \times 1.2 = 39.3 \text{ KW}$$



Note: Element watt density is critical in choosing the correct circulation heater and is dependent upon maximum operating temperature and steam velocity.

Standard Pipe Data

Nominal Pipe Size	Threads Per Inch	Inside Diameter (inches)	Outside Diameter (inches)	Weight Pipe (lbs/ft)	Length in Feet Containing One Cubic Foot	Gallons in One Linear Foot	Weight Water (lbs/ft of Pipe)
1/8	27	0.269	0.405	0.244	2526.000	0.0030	0.025
1/4	18	0.364	0.540	0.424	1383.800	0.0054	0.045
3/8	18	0.493	0.675	0.567	754.360	0.0099	0.083
1/2	14	0.622	0.840	0.850	473.910	0.0158	0.132
3/4	14	0.824	1.050	1.130	270.030	0.0277	0.231
1	11 1/2	1.049	1.315	1.678	166.620	0.0449	0.374
1 1/4	11 1/2	1.380	1.660	2.272	96.275	0.0777	0.648
1 1/2	11 1/2	1.610	1.900	2.717	70.733	0.1058	0.882
2	11 1/2	2.067	2.375	3.652	49.913	0.1743	1.453
2 1/2	8	2.469	2.875	5.793	30.077	0.2487	2.073
3	8	3.068	3.500	7.575	19.479	0.3840	3.200
3 1/2	8	3.548	4.000	9.109	14.565	0.5136	4.280
4	8	4.026	4.500	10.790	11.312	0.6613	5.510
5	8	5.047	5.563	14.617	7.198	1.0393	8.660
6	8	6.065	6.625	18.974	4.984	1.5008	12.510
8	8	7.981	8.625	28.551	2.878	2.5988	21.680
10	8	10.020	10.750	40.483	1.826	4.0963	34.100
12	8	12.000	12.750	49.560	1.274	5.9036	49.000
14	8	13.250	14.000	54.570	1.046	7.1928	59.700
16	8	15.250	16.000	62.580	0.789	9.5301	79.100
18	8	17.250	18.000	70.590	0.617	12.1928	101.200

Barlow's Formula

Pressure ratings of fluid vessels depend mainly on the tensile strength of the material being used at the process temperature, and the wall thickness of the vessel. Normally, the safety factor ratio should be at least 4 to 1 in determining the maximum pressure a vessel may see.

$$\text{Minimum wall thickness (in)} = \frac{\text{Maximum Pressure (PSI)} \times \text{OD of vessel (in)}}{2 \times \text{Tensile Strength (PSI) at process temperature}}$$

Percent of Rated Wattage for Various Applied Voltages

Applied Voltage	Rated Voltage														Applied Voltage
	110	115	120	208	220	230	240	277	380	415	440	460	480	550	
110	100%	91%	84%	28%	25%	23%	21%	16%	8.4%	7%	6.3%	5.7%	5.3%	4%	110
115	109%	100%	92%	31%	27%	25%	23%	17%	9.2%	7.7%	6.8%	6.3%	5.7%	4.4%	115
120	119%	109%	100%	33%	30%	27%	25%	19%	10%	8.4%	7.4%	6.8%	6.3%	4.8%	120
208			300%	100%	89%	82%	75%	56%	30%	25%	22%	20%	19%	14%	208
220				112%	100%	91%	84%	63%	34%	28%	25%	23%	21%	16%	220
230				122%	109%	100%	92%	69%	37%	31%	27%	25%	23%	17%	230
240				133%	119%	109%	100%	75%	40%	33%	30%	27%	25%	19%	240
277							133%	100%	53%	45%	40%	36%	33%	25%	277
380								188%	100%	84%	75%	68%	63%	48%	380
415									119%	100%	89%	81%	75%	57%	415
440										112%	100%	91%	84%	64%	440
460										123%	109%	100%	92%	70%	460
480											119%	109%	100%	76%	480
550											156%	143%	131%	100%	550

To determine the resultant wattage on a voltage not shown in the chart above, use the following formula:

$$\text{Actual Wattage} = \frac{\text{Rated Wattage} \times (\text{Applied Voltage})^2}{(\text{Rated Voltage})^2}$$



Applying higher than the actual rated voltage to heating elements will increase the watt density (watts/in.sq.), which can lead to premature heater failure and/or damage the material being heated.

Watt Density Calculations

Band Heaters

$$\text{Watts/In}^2 = \frac{\text{Wattage}}{(\text{Diameter} \times 3.1416 \times \text{Width}) - (\text{Cold Area})}$$

Cartridge and Tubular Heaters

$$\text{Watts/In}^2 = \frac{\text{Wattage}}{\text{Diameter} \times 3.1416 \times \text{Heated Length}}$$

Mica Strip Heaters

$$\text{Watts/In}^2 = \frac{\text{Wattage}}{\text{Heated Length} \times \text{Width}}$$

Channel Strip Heaters

$$\text{Watts/In}^2 = \frac{\text{Wattage}}{\text{Heated Length} \times 3.625}$$

Ohm's Law

Volts

$$\begin{aligned} \text{Volts} &= \sqrt{\text{Watts} \times \text{Ohms}} \\ \text{Volts} &= \frac{\text{Watts}}{\text{Amperes}} \\ \text{Volts} &= \text{Amperes} \times \text{Ohms} \end{aligned}$$

Ohms

$$\begin{aligned} \text{Ohms} &= \frac{\text{Volts}}{\text{Amperes}} \\ \text{Ohms} &= \frac{\text{Watts}}{\text{Amperes}^2} \\ \text{Ohms} &= \frac{\text{Volts}^2}{\text{Watts}} \end{aligned}$$

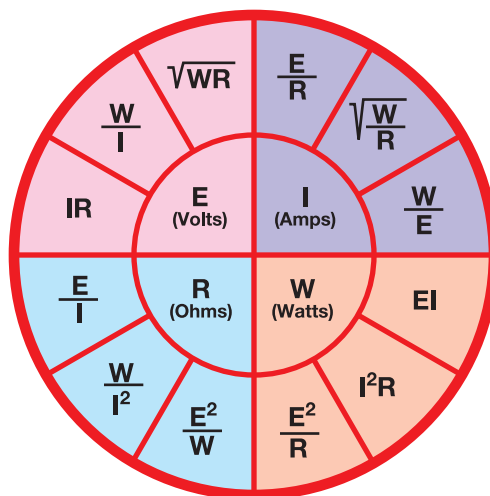

Amperes

$$\begin{aligned} \text{Amperes} &= \frac{\text{Volts}}{\text{Ohms}} \\ \text{Amperes} &= \frac{\sqrt{\text{Watts}}}{\text{Ohms}} \\ \text{Amperes} &= \frac{\text{Watts}}{\text{Volts}} \end{aligned}$$

Watts

$$\begin{aligned} \text{Watts} &= \text{Volts} \times \text{Amperes} \\ \text{Watts} &= \text{Amps}^2 \times \text{Ohms} \\ \text{Watts} &= \frac{\text{Volts}^2}{\text{Ohms}} \end{aligned}$$

Wiring Information

Amperage Conversion Table

Watts	Volts Single Phase			Volts 3 Phase Balanced Load		Watts
	120	240	480	240	480	
100	0.83	0.42	0.21	0.24	0.12	100
150	1.3	0.63	0.31	0.36	0.18	150
200	1.7	0.83	0.42	0.48	0.24	200
250	2.1	1.0	0.52	0.60	0.30	250
300	2.5	1.3	0.63	0.72	0.36	300
350	2.9	1.5	0.73	0.84	0.42	350
400	3.3	1.7	0.83	1.0	0.48	400
450	3.8	1.9	0.94	1.1	0.54	450
500	4.2	2.1	1.0	1.2	0.60	500
600	5.0	2.5	1.3	1.4	0.72	600
700	5.8	2.9	1.5	1.7	0.84	700
750	6.3	3.1	1.6	1.8	0.90	750
800	6.7	3.3	1.7	1.9	1.0	800
900	7.5	3.8	1.9	2.2	1.1	900
1000	8.3	4.2	2.1	2.4	1.2	1000
1100	9.2	4.6	2.3	2.6	1.3	1100
1200	10.0	5.0	2.5	2.9	1.4	1200
1250	10.4	5.2	2.6	3.0	1.5	1250
1300	10.8	5.4	2.7	3.1	1.6	1300
1400	11.7	5.8	2.9	3.4	1.7	1400
1500	12.5	6.3	3.1	3.6	1.8	1500
1600	13.3	6.7	3.3	3.8	1.9	1600
1700	14.2	7.1	3.5	4.1	2.0	1700
1750	14.6	7.3	3.6	4.2	2.1	1750
1800	15.0	7.5	3.8	4.3	2.2	1800
1900	15.8	7.9	4.0	4.6	2.3	1900
2000	16.7	8.3	4.2	4.8	2.4	2000
2200	18.3	9.2	4.6	5.3	2.6	2200
2500	20.8	10.4	5.2	6.0	3.0	2500
2750	22.9	11.5	5.7	6.6	3.3	2750
3000	25.0	12.5	6.3	7.2	3.6	3000
3500	29.2	14.6	7.3	8.4	4.2	3500
4000	33.3	16.7	8.3	9.6	4.8	4000
4500	37.5	18.8	9.4	10.8	5.4	4500
5000	41.7	20.8	10.4	12.0	6.0	5000
6000	50.0	25.0	12.5	14.4	7.2	6000
7000	58.3	29.2	14.6	16.8	8.4	7000
8000	66.7	33.3	16.7	19.2	9.6	8000
9000	75.0	37.5	18.8	21.7	10.8	9000
10000	83.3	41.7	20.8	24.1	12.0	10000

Wiring Hints

- Wire gauge, conductor material, and wire insulation choice depend upon current draw, electric service voltage and operating temperature. In high temperature environments, high temperature insulation and/or nickel coated copper or nickel conductors may be required.
- Heater terminal connections should be tightened with maximum torque consistent with terminal strength. When possible, a wrench or pliers should be used to support the heater terminal to prevent it from twisting when tightening connections.
- It is good wiring practice to run thermocouple circuit wiring in a separate conduit.
- Thermostat capillary tubing must be kept away from heater terminals.
- Safe operation of heaters equipped with NEMA 4 and NEMA 7 terminal housings depends on electrical wiring meeting the national electrical code for these locations and limiting maximum operation temperatures. Approved pressure and/or temperatures limiting controls must be used to assure safe operation in the event of system malfunctions.
- An integral thermostat functions as a temperature control only and is not a fail-safe device. An approved pressure and/or temperature limit control should be used in the event of system malfunctions.
- Never perform any type of service on heaters prior to disconnecting all electrical power.



All wiring should be done in accordance with the National Electrical Code and applicable local codes.

Selection of Hook-Up Lead Wire Gauge

Approximate Current Carrying Capacities of High Temperature insulated Nickel (Grade "A") and Nickel Plated Copper wire based on ambient temperature of 40°C (104°F).

This table should only be used as a starting point when establishing ratings for any given situation. It is recommended that design engineers desiring accurate ampacity data refer to the current National Electric Code Handbook, Article 310-15-310-84.

Current Carrying Capacity Table Ambient Temperature at 40°C (104°F)

Conductor Size AWG	Conductor Type and Temperature Rating			
	250°C (482°F) "A" Nickel	250°C (482°F) NPC 2%-10%	450°C (842°F) "A" Nickel	450°C (842°F) NCC 27%
24	4	8	4.3	9
22	5	10.8	5.6	12
20	7	15	8	18
18	9.4	20	11	23
16	12	26	14	30
14	18	39	21	45
12	25	54	26	56
10	34	73	35	75

For ambient temperatures other than 40°C (104°F), multiply the ampacities shown above by the appropriate factor shown below.

Ambient Temperature Correction Factors

Ambient Temperature °C	Wire Temperature Rating		Ambient Temperature °F
	250°C (482°F)	450°C (842°F)	
41-50	0.98	0.99	106-122
51-60	0.95	0.99	124-140
61-70	0.93	0.96	142-158
71-80	0.9	0.95	160-176
81-90	0.87	0.93	177-194
91-100	0.85	0.92	195-212
101-120	0.79	0.89	213-248
121-140	0.71	0.86	249-284
141-160	0.65	0.84	285-320
161-180	0.58	0.81	321-356
181-200	0.49	0.78	357-392
201-225	0.35	0.74	393-437
226-250	—	0.69	439-482
251-275	—	0.65	483-527
276-300	—	0.6	528-572
301-325	—	0.55	573-617
326-350	—	0.49	618-662
351-375	—	0.42	663-707
376-400	—	0.34	708-752

Wiring Diagrams

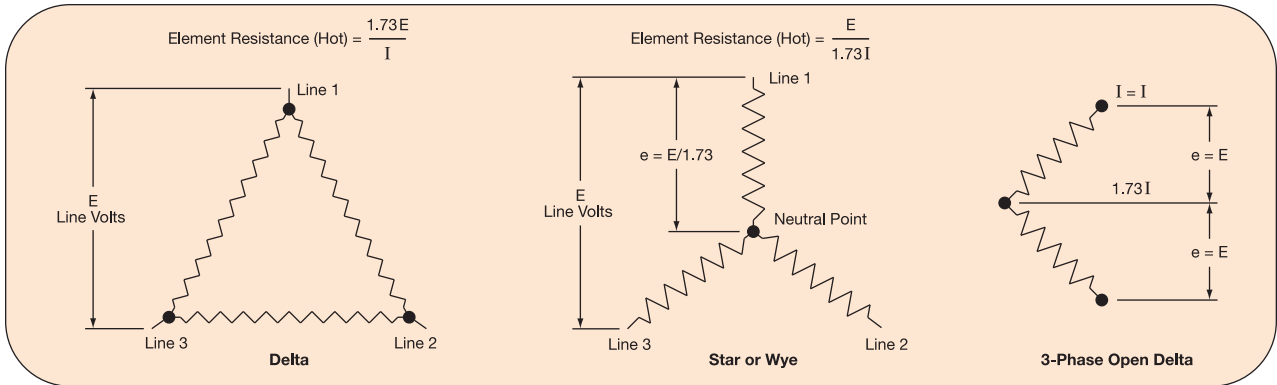

For current in 3 phase circuits: $I = \frac{W}{1.73E}$

Note: If elements are designed for 3-phase delta connection wattage output may be reduced to 1/3 by rewiring to 3-phase WYE.

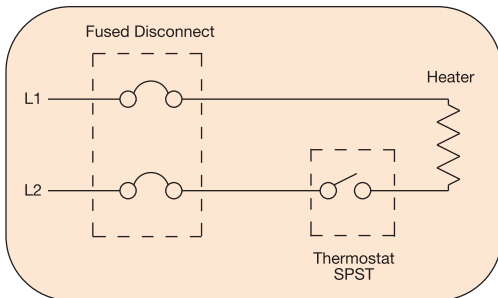

Single-phase circuit with SPST thermostat.

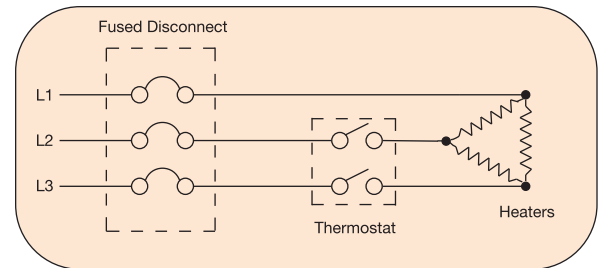

Three-phase circuit with DPST thermostat.

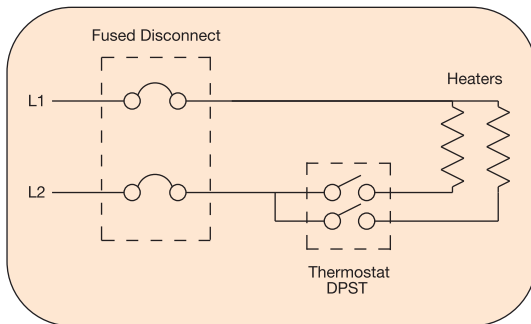

Single-phase circuit with thermostat connected for half current load across each contact.

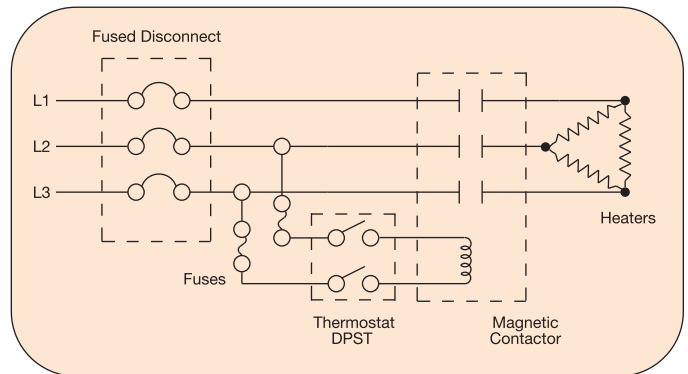

Three-phase circuit when line current exceeds thermostat rating.

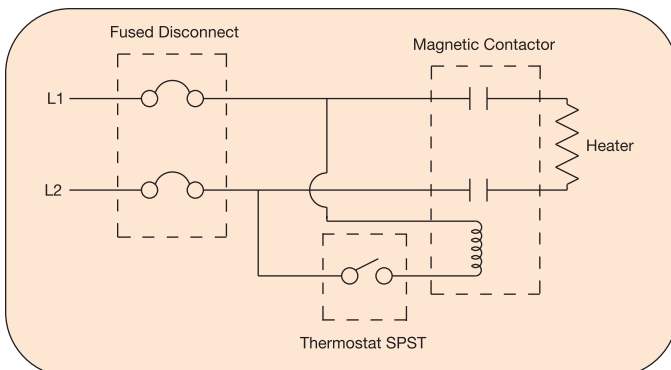

Single-phase circuit when line current exceeds thermostat rating.

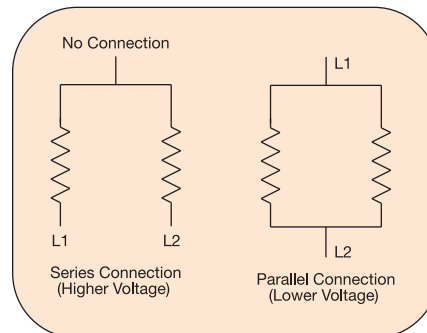

Dual Voltage

Example: Two 120V heaters wired in parallel for 120V operation or wired in series for 240V operation.

NOTE: To reduce wattage in a system, two heaters rated at 240 volts wired in series to a 240 volt power supply will generate 1/4 of their rated wattage.

Sheath Material Selection Guide

CORROSION POLICY

TEMPCO cannot warrant any electric immersion heater against failure by sheath corrosion if such failure is the result of operating conditions beyond the control of the heater manufacturer. The facts and recommendations appearing in the TEMPCO catalog or any other literature published by TEMPCO are based on our own research and the research of others, and are believed to be accurate. We cannot anticipate all conditions under which this information and our products, or the products of other manufacturers in combination with our products, may be used.

We accept NO responsibility for results obtained by the application of this information or the safety and suitability of our products, either alone or in combination with other products. It is the responsibility of the Purchaser to make the ultimate choice of sheath material based on his/her knowledge of the chemical composition of the corrosive solution, character of materials entering the solution, and controls, which he/she maintains, on the process.

Examples of process variables that can affect heater sheath selection

- * Solution chemistry
- * Solution contamination
- * Temperature
- * Flow rate (velocity) past heater
- * Heater watt density
- * Heating cycle (time-on, time-off)
- * Galvanic behavior
- * Degree of aeration

Key to Notes in Sheath Material Selection Guide:

1. This solution contains a mixture of various chemical compounds whose identity and proportions are unknown or subject to change. Check with chemical supplier to confirm suitability of sheath material chosen.
2. Caution—flammable material.
3. Chemical composition varies widely. Check supplier for specific recommendations.
4. Direct immersion heaters not practical. Use clamp-on heaters on outside surface of cast iron pot.
5. Element surface loading should not exceed 20 watts per square inch.
6. For concentrations greater than 15%, element surface loading should not exceed 20 watts per square inch.
7. See suggested watt density chart.
8. Remove crusts at liquid level.
9. Clean often.
10. Passivate stainless steel, Inconel® and Incoloy®.



Maximum Recommended Watt Densities for Various Materials

Material Being Heated	Maximum Operating Temperature °F	Maximum Watt Density W/in ²
Acid Solutions	180	40
Alkaline Solutions, Oakite	212	40
Ammonia Pltg. Solution	50	25
Asphalt, Tar or Heavy Compounds	200-500	4-10
Caustic Soda 2%	210	45
10%	210	25
75%	180	25
Degreasing Solution Vapor	275	20
Electroplating Solution	180	40
Ethylene Glycol	300	30
Fatty Acids	150	20
Fuel Oils		25-30 circ.
Light Grade	180	8
Heavy (Bunker C)	160	23
Gasoline	300	10
Glycerine	500	

Material Being Heated	Maximum Operating Temperature °F	Maximum Watt Density W/in ²
Machine Oil SAE 30	250	15-20 non-circ.
Metal Melting Pot	500-900	20-27
Mineral Oil	400	16
Molasses	100	4-5
Molten Tin	600	20
Oil Draw Bath	600	20
Paraffin or Wax	150	16
Potassium Hydroxide	160	25
Propylene Glycol	150	20
Steel Tubing Cast Into Aluminum	500-750	50
Steel Tubing Cast Into Iron	750-1000	55
Trichlorethylene	150	20
Water (Process)	35-150	100-125 circ.
	212	75-100 non-circ.
		75 circ.
		50 non-circ.

Media Being Heated	Element Sheath Material																*Notes		
	Iron & Steel	Gray Cast Iron	Cast Iron Ni-Resist	Aluminum	Copper	Lead	Monel 400	Nickel 200	304, 321, 347 Stn. Stl.	316 Stn. Stl.	Type 20 Stn. Stl.	Incoloy® 800	Inconel® 600	Titanium	Hastelloy B	Quartz		Graphite	Teflon®
Acetaldehyde					A				A	A									Note 2
Acetic Acid, Crude	X		C	F	F	X	F	F	F	F		C	C						
Pure			X	A	F	F	A	F				C	C						
Vapors			X	C	F	X	F	F				C	C	F					
150 PSI; 400°F				C	F	X	F	F				C	C						
Aerated	X	X	X	C	X	X	X	X	X	F	F		X	A					
No Air		X	X	C	F	X	A	F	C	F	F		X	A					
Acetone	C	X	F	F	A	A	A	A	A	A	A	A	A	A	A	A	A		Note 2
Actane™ 70																	A	A	Note 1
Actane™ 80																	A	A	Note 1
Actane™ Salt																	A		Note 1
Alboloy Process	A																		
Alcoa™ R5 Bright Dip																A		A	Note 1
Alcohol	F	F		F	A	A	A	A	F	A	A	A	A	A	A	A	A		Note 2
Allyl Alcohol		A	A	F	A	F	A	A	A	A	A	A	A						
Alcorite™														A					Note 1
Alkaline Cleaners									A										Note 1
Alkaline Soaking Cleaners	A																		Note 1
Alodine™										A									Note 1
Aluminum (Molten)	CONSULT TEMPCO																		
Aluminum Acetate	X	X			F	A	F	F	F	A	A		F	A	A				
Aluminum Bright Dip																A		A	Note 1
Aluminum Chloride	X	X		X	X	X	X	X	X	X	X	X	X	X	A	A	A	A	Note 1
Aluminum Cleaners	C	C		X	X	X	A	A	A	A	F	A	A	F		X	X		Notes 1, 9
Aluminum Potassium Sulfate (Alum)		X	X	X	A	F	F	F	X	C	F		F	F					
Aluminum Sulfate	X	X	X	X	X	F	X	X	F	F	F	X	X	A		A	A		Note 1
Ammonia	X	X		C	X	C	X	X	X	X	C	F	A	A	A	A			
Ammonia (Anhydrous) (Gas)	F				X				A	A									
Cold	C		A	A	A	F	A	A	A	A		A	A						
Hot	C		C		A	X	A	A	C	C	A		A						
Ammonia and Oil	A																		
Ammonium Acetate	A	F	F	A	X	X	A	A	A	A	A	A							
Ammonium Chloride	X	X	F	X	X	X	F	F	X	C	C	C	C		A	A	A		
Ammonium Hydroxide	F	F	F	C	X	F	X	A	A	A	A	A	A		X	A			
Ammonium Nitrate	F	X	C	F	X	X	X	X	A	A	A	X	X	X		A	A		
Ammonium Persulfate	X	X		X	X	C	X	X	F	F	F		X			A	A	A	
Ammonium Sulfate	X	X	F	X	X	F	F	F	C	F	F	F	F	A		A	A		
Amyl Acetate	F				A		A	A	A	A	A		A						
Amyl Alcohol	A	F	F	C	A		A	F	A304	A	A	A	A	A		A			Note 2
Aniline	F	A		F	X	F	F	F	A304	A	A	F	F	A		A	A		
Aniline, Oil	A			X	X				A	A									
Aniline, Dyes							A		A	A									

Corrosion Resistance Ratings:

A = Good

F = Fair

C = Depends on Conditions

X = Unsuitable

Blank = Data Not Available

* See Key to Notes in Material Selection Guide on Page 16-12.



Recommended Sheath Materials

Media Being Heated	Element Sheath Material														*Notes				
	Iron & Steel	Gray Cast Iron	Cast Iron Ni-Resist	Aluminum	Copper	Lead	Monel 400	Nickel 200	304, 321, 347 Stn. Stl.	316 Stn. Stl.	Type 20 Stn. Stl.	Incoloy® 800	Inconel® 600	Titanium		Hastelloy B	Quartz	Graphite	Teflon®
Anodizing Solutions (10%)																			
Chromic Acid 96°F	C								A	A				A					
Nickel Acetate						C	A	F											
Nigrosine Black Dye							F	F											
Sodium Hydroxide Alkaline	A			A				A		A	A		A						
Sulfuric Acid 70°F						A					A								
ARP™ 28																	A	A	Note 1
ARP™ 80 Blackening Salt																	A		Note 1
Arsenic Acid	X	X		X	X	X	X	X	C	F	F	X	X	X		A	A	A	
Asphalt	A	A		X	X	X	X	A	A	A	A	A	A	A		A	A		
Barium Chloride				X				A	F	F									
Barium Hydroxide	F	F		X	X	X	F	A	F	A	A	F	F	X		A	A		
Barium Sulfate	F	F	F		F	F	F	F	F	F	F	F	F	A		A	A		
Barium Sulfite										F									
Black Nickel																A		A	Note 5
Black Oxide										A									Note 5
Bleaching Solution 1½ lb. Oxalic Acid per Gallon of H ₂ O at 212°F							A		F										
Bonderizing™ (Zinc Phosphate)	C		F						A	A									
Boric Acid	X	X		X	C	C	C	C	C	C	C	C	C	A	A	A	A	A	
Brass Cyanide										A									Note 1
Bright Nickel														A		A			Notes 1, 5
Brine (Salt Water)							A						F						
Bronze Plating	A									A									Note 1
Butanol	A	A		F	A	A	A	A	A	A	A	A	A		A	A	A		Note 2
Cadmium Black																A			Note 1
Cadmium Fluoborate																	A	A	Note 1
Cadmium Plating									A			A	A						Note 1
Calcium Chlorate	F	F		F	C	C	F	F	F	F	F	F			A				
Calcium Chloride	F	F		C	F	X	F	F	F	F	F	F	F	A	A	A	A	A	
Carbon Dioxide—Dry Gas	X	X	A	A	A	F	A	A	A	A	A	A	A	X		A	X	X	
Carbon Dioxide—Wet Gas	X	X	C	A	X	F	A	A	A	A	A	A	A	X		A	X	X	
Carbon Tetrachloride	X	X	C	X	C	A	A	A	C	F	F	A	A	A		A			
Carbonic Acid	C	C		C	C	X	C	C	A	F	A	F	A	A		A	A	A	
Castor Oil	A	A		A	A	A	A	A	A	A	A	A	A	A		A	A	A	
Caustic Etch	A	A		X	X		A	A	A	A	X	X	X	A		X	A	X	
Caustic Soda (Lye) (Sodium Hydroxide) 2%	F	F	F	X	F	X	A	A	X	F	A	A	A	A					
10–30%, 210°F	F	F	A	X	F	X	A	A	A	A	A	A	A	A					
76%, 180°F	X	X	X	X	X	X	F	A	F	F	F	A	A	F					
Chlorine Gas: Dry	X	X	F	X	X	X	F	C	C	C	F	C	F	X		A	F	F	Note 2
Wet	X	X	X	X	X	X	X	X	X	X	X	X	X	F		A	X	X	Note 2
Chloroacetic Acid	X	X		X	X	X	F	F	X	X		C	C	A		A	A	A	
Chromic Acetate																A			Note 1

Corrosion Resistance Ratings:

A = Good

F = Fair

C = Depends on Conditions

X = Unsuitable

Blank = Data Not Available

* See Key to Notes in Material Selection Guide on Page 16-12.

Media Being Heated	Element Sheath Material																	*Notes	
	Iron & Steel	Gray Cast Iron	Cast Iron Ni-Resist	Aluminum	Copper	Lead	Monel 400	Nickel 200	304, 321, 347 Stn. Stl.	316 Stn. Stl.	Type 20 Stn. Stl.	Incoloy® 800	Inconel® 600	Titanium	Hastelloy B	Quartz	Graphite		Teflon®
Chrome Plating	X	X		X	X	F	X	X	X	X	X	X	A		A	A	X		
Chromic Acid	X	C	X	X	X	F	X	X	X	X	X	X	A		A	A	X		
Chromylite															A			Note 1	
Citric Acid	X	X	C	C	C	X	F	F	C	C	F	F	A	A	A	A	A		
Clear Chromate										A								Note 1	
Cobalt Acetate at 130°F							F	F	A	A		F	F						
Cobalt Nickel															A			Notes 1, 6	
Cobalt Plating									A						A			Note 1	
Coconut Oil						F	A												
Cod Liver Oil				A				A	A	A	A	A							
Copper Acid													A		A			Note 1	
Copper Bright									A	A								Note 1	
Copper Bright Acid															A				
Copper Chloride	X	X		C	X	C	X	X	X	X	X	X	A		A	A	A		
Copper Cyanide	A	A		X	X		C	X	F	F	F	X	X		A	A	A		
Copper Fluoborate							F	F	F	F	F	F				A	A		
Copper Nitrate	X	X	X	X	X		X	X	F	F	F	X	X		A	A	A		
Copper Plating	A																		
Copper Pyrophosphate									A									Note 1	
Copper Strike	A	A							A									Note 1	
Copper Sulfate	X	X	F	X	C	A	X	X	F	F	A	C	X	A	A	A	A		
Creosote	A	F	F	C	F	X	F	F	F	F	F	F			A			Note 2	
Cresylic Acid	C	C		C	C	X	F	F	F	A	A	C	F	F	A	A	A	Note 2	
Deoxidine™									A										
Deoxlyte™									A										
Deoxidizer (Etching)															A			Note 1	
Deoxidizer (3AL-13)									A	A								Note 1, Non-Chromate	
Dichromic Seal	X	X																	
Diethylene Glycol	F	A		F	F	A	F	F	A	A	A	F	F	A	A	A	A		
Diphenyl 300° - 350°F	A	A	A	A	A	A	A	A	A		A		A						
Disodium Phosphate	A																		
Diversey™ DS9333															A			Note 1	
Diversey™ 99	A																		
Diversey™ 511															A			Notes 1, 5	
Diversey™ 514																A	A	Note 1	
Dowtherm™ A	A																		
Electro-Polishing																		Note 1	
Electroless Nickel													A		A			Note 1	
Electroless Tin (Acid)															A			Note 1	
(Alkaline)										A			A					Note 1	
Enthone Acid-80																	A	A	Note 1
Ether	F	F		F	F	F	F	F	F	F	A	F	F	A	A			Note 2	
Ethyl Chloride	F	F		F	A	F	F	A	F	F	A	F	A	A	A	A	A	Note 2	



CORROSION POLICY

TEMPCO cannot warrant any electric immersion heater against failure by sheath corrosion if such failure is the result of operating conditions beyond the control of the heater manufacturer. The facts and recommendations appearing in the TEMPCO catalog or any other literature published by TEMPCO are based on our own research and the research of others, and are believed to be accurate. We cannot anticipate all conditions under which this information and our products, or the products of other manufacturers in combination with our products, may be used.

We accept NO responsibility for results obtained by the application of this information or the safety and suitability of our products, either alone or in combination with other products. It is the responsibility of the Purchaser to make the ultimate choice of sheath material based on his/her knowledge of the chemical composition of the corrosive solution, character of materials entering the solution, and controls, which he/she maintains, on the process.



Recommended Sheath Materials

Media Being Heated	Element Sheath Material																	*Notes
	Iron & Steel	Gray Cast Iron	Cast Iron Ni-Resist	Aluminum	Copper	Lead	Monel 400	Nickel 200	304, 321, 347 Stn. Stl.	316 Stn. Stl.	Type 20 Stn. Stl.	Incoloy® 800	Inconel® 600	Titanium	Hastelloy B	Quartz	Graphite	
Ethylene Glycol	A	F		A	F	X	F	F	F	F	F	F	A		A	A	A	Note 5
Fatty Acids	X	X		A	X	X	F	F	F	A	A	F	F	A	A	A		
Ferric Chloride	X	X	X	X	X	X	X	X	X	X	X	X	A		A	A	A	
Ferric Nitrate	X	X		X	X		X	X	F	F	A	X	X		A	A		
Ferric Sulfate	X	X	X	X	X	A	X	C	F	F	F	C	C	A	A	A		
Fluorine Gas, Dry	C	X		X	X	X	A	A	C	C	C	C	A	A	C	X		
Formaldehyde	X	X	F	F	F	X	F	F	A	A	A	F	F	A	A	A		
Formic Acid	X	X		X	F	X	C	C	X	X	A	F	C	X	A	A		
Freon	A	A	A	A	A	A	A	A	A	A	A	A	A					
Fuel Oil	A	A		A	A	A	F	F	A	A	A	F	F	A				Notes 2, 3, 7
Fuel Oil - Acid	X	X		X	X	A	C	C	C	F	A	C	C	A				Notes 2, 3, 7
Gasoline - Refined	A	A	A	A	A	A	F	F	A	A	A	F	F		A	A		Notes 2, 5
Gasoline - Sour	C	C		C	C	A	X	X	F	F	A	X	X		A	A		Notes 2, 3, 5
Glycerine, Glycerol	F	C	F	A	F	F	A	A	A	A	A	A	A		A	A		
Gold Acid	A												A		A			Note 1
Gold Cyanide									A	A								Note 1
Grey Nickel													A		A		A	Notes 1, 5
Holdens 310A Tempering Bath								A										
Hot Seal Sodium Dichromate										A								Note 1
Houghtone Mar Tempering Salt	C							C										
Hydrocarbons - Aliphatic	A	A		A	A		A	A	A	A	A	A	A		A	A		Note 2
Hydrocarbons - Aromatic	A	A		A	A		A	A	A	A	A	A	A		A	A		Note 2
Hydrochloric Acid < 150°F	X	X	X	X	X	X	X	X	X	X	X	X	X	X	A	A		
> 150°F	X	X		X	X	X	X	X	X	X	X	X	X	X	A	A	A	
Hydrocyanic Acid	X	X		F	X	X	F	F	F	F	F	F	F		A	A		
Hydrofluoric Acid, Cold < 65%	X	X	X	X	X	X	C	X	X	X	X	X	X	X	X	A	A	Note 5
> 65%	F	X	X	X	X	X	C	X	X	X		X	X	X				
Hydrofluoric Acid, Hot < 65%	X			X	X	X	C	X	X									
> 65%	X			X	X	X	C	X	X	X		X	X	X				
Hydrogen Peroxide	X	X	X	A	X	X	C	F	F	F	F	F	F	A	A	X		
Indium															A		A	Note 1
Iridite™ #4-75, #4-73, #14, #14-2, #14-9, #18-P										A								Note 1
Iridite™ #1, #2, #3, #4-C, #4PC&S, #4P-4, #4-80, #4L-1, #4-2, #4-2A, #4-2P, #5P-1, #7-P, #8, #8-P, #8-2, #12-P, #15, #17P, #18P															A			Note 1
Iridite™ Dyes #12L-2, #40, #80															A		A	Note 1
Irillac™															A		A	Note 1
Iron Fluoborate																A	A	Note 1
Iron Phosphate (Parkerizing)	C		F						A	A								
Isoprep™ Deoxidizer #187, #188										A								Note 1
Isoprep™ #191 Acid Salts																A	A	Note 1

Corrosion Resistance Ratings:

A = Good

F = Fair

C = Depends on Conditions

X = Unsuitable

Blank = Data Not Available

* See Key to Notes in Material Selection Guide on Page 16-12.

Media Being Heated	Element Sheath Material																*Notes		
	Iron & Steel	Gray Cast Iron	Cast Iron Ni-Resist	Aluminum	Copper	Lead	Monel 400	Nickel 200	304, 321, 347 Stn. Stl.	316 Stn. Stl.	Type 20 Stn. Stl.	Incoloy® 800	Inconel® 600	Titanium	Hastelloy B	Quartz		Graphite	Teflon®
Isoprep™ Acid Aluminum Cleaner #186									A										Note 1
Isopropanol	C				A		A	A	A	A		A							
Jetal™									A										Note 1
Kerosene	A			A	A		A	A	A	A	A	A					A		Note 2
Kolene									A										
Lacquer Solvent	F	A	A	A	F	A	F	F	A	A	A	F	F	A		A			Note 2
Lead Acetate	X	X		X	X	X	A	A	A	A	A	A	A		A	A			
Lead Acid Salts									A										Note 1
Lime Saturated Water	F	F		X	F	X	F	F	F	A	F	F	F			X	A		
Linseed Oil	X	A		F	F	X	F	F	A	A	A	F	F			A	X		Note 2
Magnesium Chloride	X	C	F	X	F	X	F	A	F	F	A	F	A	A		A	A		
Magnesium Hydroxide	A	A	A	F	A	A	F	A	A	A	A	A	A			A	A		
Magnesium Nitrate	F	F		F	F	C	F	F	F	F	F	F	X	F		A	A		
Magnesium Sulfate	F	F	F	F	F	A	A	A	F	F	A	F	A	A		A	A		
MacDermid™ M629																	A	A	Note 1
Mercuric Chloride	X	X	X	X	X	X	X	X	X	X	X	X	X	F		A	A		
Mercury	A	A	A	X	X	X	F	F	F	A	A	A	F	X		A			
Methyl Alcohol (Methanol)	F	F		C	F	F	A	A	F	A	A	F	A	A		A	A		Note 2
Methyl Bromide	C	C		X	F	F	F	F	A	A	A	F	F	A		A			
Methyl Chloride	C	C		X	A	C	C	C	C	C	C	C	C	A		A	A		
Methylene Chloride	X	C		C	C	F	C	F	C	F	A	C	F	A		A	A		
Mineral Oil	A	A		A	A	A	A	A	A	A	A	A	A	A		A	A		
Muriato																	A	A	Note 1
Naptha	A	F	F	A	A	A	A	A	A	A	A	A	A	A		A	A	A	Note 2
Napthalene	A	A	A	F	F	A	F	F	A	A	A	F	F	A					Note 2
Nickel Acetate Seal										A									Note 1
Nickel Chloride	X	X	X	X	X	C	C	X	X	C	C	C	F	F		A	A	A	Notes 1, 5
Nickel Copper Strike (Cyanide Free)									A	A									Note 1
Nickel Plate - Bright						A								A		A		A	Notes 1, 5
Nickel Plate - Dull						A										A		A	Notes 1, 5
Nickel Plate - Watts Solution														A		A		A	Notes 1, 5
Nickel Sulfate	X	X	X	X	F	F	C	F	F	F	F	C	F			A	A	A	
Nitric Acid, Crude	X				X	X	X	X	C	C		X	X			A		A	
Concentrated	X				X	X	X	X	F	F		X	X			A		A	
Diluted	X				X	X	X	X	A	A		X	X			A		A	
Nitric Hydrochloric Acid	X	X		X	X	X	X	X	X	X	X	X	X	X		A	A	A	
Nitric 6% Phosphoric Acid										C						A		A	Note 1
Nitric Sodium Chromate										A						A		A	Note 1
Nitrobenzene	A	A	A	A	F	X	A	A	A	A	A	A	A	A		A			Note 2
Oakite™ #67									A										Note 1
Oakite™ #20, 23, 24, 30, 51, 90	A																		
Oleic Acid	C	C	C	C	C	X	F	F	C	F	A	F	A	F		A	A	A	



CORROSION POLICY

TEMPCO cannot warrant any electric immersion heater against failure by sheath corrosion if such failure is the result of operating conditions beyond the control of the heater manufacturer. The facts and recommendations appearing in the TEMPCO catalog or any other literature published by TEMPCO are based on our own research and the research of others, and are believed to be accurate. We cannot anticipate all conditions under which this information and our products, or the products of other manufacturers in combination with our products, may be used.

We accept NO responsibility for results obtained by the application of this information or the safety and suitability of our products, either alone or in combination with other products. It is the responsibility of the Purchaser to make the ultimate choice of sheath material based on his/her knowledge of the chemical composition of the corrosive solution, character of materials entering the solution, and controls, which he/she maintains, on the process.



Recommended Sheath Materials

Media Being Heated	Element Sheath Material																	*Notes	
	Iron & Steel	Gray Cast Iron	Cast Iron Ni-Resist	Aluminum	Copper	Lead	Monel 400	Nickel 200	304, 321, 347 Stn. Stl.	316 Stn. Stl.	Type 20 Stn. Stl.	Incoloy® 800	Inconel® 600	Titanium	Hastelloy B	Quartz	Graphite		Teflon®
Oxalic Acid	X	X	X	F	F	X	C	F	X	X	F	X	F	X		A	A	A	
Paint Stripper (High Alkaline Type)	A																		Note 1
Paint Stripper (Solvent Type)										A									Notes 1, 2
Paraffin	A	A		A	A		F		A	A	A								Notes 2, 7
Parkerizing™ (See Iron Phosphate)																			
Perchloroethylene	F	F		C	F	F	A	A	F	F	F	F	A	A		A			
Perm-A-Clor™									A										
Petroleum - Crude < 500°F	F	F	A	A	C	C	A	C	A	A	A				A	A			Notes 2, 3, 7
> 500°F	A		A	A	X	X	X	X	A										
> 1000°F	X			X	X	X	X	X	A347										
Phenol	F	F		F		X	F		C	F	F	F	F	A	A				
Phosphate										A								X	Notes 1, 5, 9
Phosphate Cleaner									A									X	Notes 1, 5, 9
Phosphatizing										A								X	Notes 1, 5, 9
Phosphoric Acid, Crude	C			X	X	C	X	X	C										
Pure < 45%	X	X	X	C	C	C	F	C	C	C	F	A	A	X					
> 45% Cold	X	X	X	X	F	C	F	C	A	F	F	A		X					
> 45% Hot	X	X	X	X	C	X	C	X	X	X	F	A	F	X					
Photo Fixing Bath									C	A									
Picric Acid	X	X		X	X	X	X	X	F	F	F	C	C			A	A	A	
Potassium Acid Sulfate															A		A		Note 1
Potassium Bichromate	C	F	F	F		F	F	F	A347	A	A	F		F	A	A		A	
Potassium Chloride	C	X	F	X	C	C	F	F	C	F	A	C	F	A		A	A		
Potassium Cyanide	C	X	F	X	X	X	C	F	F	F	F	F	F	X		A	C	A	
Potassium Dichromate									A347										
Potassium Hydrochloric																A		A	Note 1
Potassium Hydroxide	X	X		X	C	X	F	A	C	C	C	C	F	X		X	A	A	
Potassium Nitrate	F	F	F	A	F	F	F	F	F	F	F	F	F	A		A	A		
Potassium Sulfate	C	C	C	A	F	A	A	F	A	A	A	F	F	A		A	A	A	
Prestone™ 350°F	A						A												
R5 Bright Dip For Copper Polish at 180°F										A									
Reynolds Brightener																A		A	Note 1
Rhodium Hydroxide																A		A	
Rochelle Salt Cyanide	A								A										Note 1
Ruthenium Plating																A		A	Note 1
Silver Bromide	X	X		X	X		C	C	X	X	C			A		A	A	A	
Silver Cyanide	C	C		X	X		F		A	A	A	A				A			
Silver Lume									A										Note 1
Silver Nitrate	X	X		X	X	X	X	X	C	C	F	C	C	A		A	A		
Soap Solutions	A	A	A	X	C		A		A	A	A								Note 3
Sodium - Liquid Metal	C	X		X	X	X	F	A	A			A	A			X	X		

Corrosion Resistance Ratings:

A = Good

F = Fair

C = Depends on Conditions

X = Unsuitable

Blank = Data Not Available

* See Key to Notes in Material Selection Guide on Page 16-12.

Media Being Heated	Element Sheath Material																	*Notes	
	Iron & Steel	Gray Cast Iron	Cast Iron Ni-Resist	Aluminum	Copper	Lead	Monel 400	Nickel 200	304, 321, 347 Stn. Stl.	316 Stn. Stl.	Type 20 Stn. Stl.	Incoloy® 800	Inconel® 600	Titanium	Hastelloy B	Quartz	Graphite		Teflon®
Sodium Bisulfate	X	X	X	C	F	C	C	F	X	X	A	F							
Sodium Bromide	F	C		X	F	F	F	F	C	F	F	F			A	A	A		
Sodium Carbonate	C	C		X	A	X	F	F	F	F	A	F	F	A	C	A	A		
Sodium Chlorate	X	X		F	A	F	A	A	F	F	F	F	A	A	A	A	A		
Sodium Chloride	C	X	F	X	F	F	A	F	X	X	C	F	A	C	A	A			
Sodium Citrate	X	X		X	X	X			F	F	F				A	A	A		
Sodium Cyanide	C	F	C	X	X	X	C	C	A	A	A	A	C		A	C			
Sodium Dichromate (Sodium Bichromate)	F	F	F	C	X				F	F	F		C		A				
Sodium Hydroxide (See Caustic Soda)																			
Sodium Hypochlorite	X	X	X	X	X	X	X	X	X	X	F	X	X	A	A	A	A	A	
Sodium Nitrate	F	F	A	C	C	C	F	F	A	A	A	A	A		A	A			
Sodium Peroxide	F	A	F	C	X	X	F	F	F	F	F	F							
Sodium Phosphate	C	C	F	X	F	F	A	C	F	A	F	F	A	A	A	A	A		
Sodium Salicylate	F	C	F		F		F	F	F	F	F	F	F		A	A	A		
Sodium Silicate	A	F	A	X	F	X	A	A	A	A	A	A	A	A	A	A	A		Note 4
Sodium Stannate	C	C	C				F	F	F	F	F	F	F		A		A		
Sodium Sulfate	F	C		F	F	F	F	F	X	F	F	F	F	C	A	A	A		
Sodium Sulfide	C	X	C	C	X	A	F	F	X	C	C	C	C	C	C	A	A		
Solder Bath	X	X	X	X	X	X	X	X	X	X	X	X	X	X	X	X	X		Note 4
Soybean Oil									A										
Sannostar™															A		A		Note 1
Steam < 500°F	A			A	A	C	A	A	A			A	A						
500° - 1000°F	C			C	C	X	C	C	A			A	A						
> 1000°F	X			X	X		X	X	A			A	A						
Stearic Acid	C	C	C	C	X	X	F	F	C	A	A	F	F	F	A	A			
Sugar Solution	A	A		A	A	A	A	A	A	A	A	A	A	A	A	A	A		Note 7
Sulfamate Nickel														A	A		A		Note 1
Sulfamic Acid	X	X		X					X	X					A		A		
Sulfur	C	X	C	A	X	X	F	C	C	F	F	A	A	A	A	A			
Sulfur Chloride	X	X	C	X	X	F	X	C	C	X	C	C	F		A	X	A		
Sulfur Dioxide	C	C		C	C	F	X	C	C	F	F	C	C	A	A	A			
Sulfuric Acid < 10% Cold	X		X	C	A	F	F	C	X	C	F		X						
Hot	X	X	X	C	X	X	X	X	X	X	X		F						
10 - 75% Cold	X			X	F	F	C	C	X	X	F		X	X					
Hot	X			X	X	F	C	X	X	X	C		X	X					
75 - 95% Cold	F	F	F	X	F	F	X	X	F	F	F			X					
Hot	X	X	X	X	X	C	X	X	X	X	X			X					
Fuming	C	X	C	X	X	X	X	X	F	C	C	C	C						
Sulfurous Acid	X	X		C	X	A	X	X	X	C	F		C	A					
Tannic Acid	C	C		C	C	X	C	C	C	A	A		A	A	A				
Tar	A			A					A			A	A						
Tartaric Acid		X	F	C		C	F	C	C	A	F		F	F					



CORROSION POLICY

TEMPCO cannot warrant any electric immersion heater against failure by sheath corrosion if such failure is the result of operating conditions beyond the control of the heater manufacturer. The facts and recommendations appearing in the TEMPCO catalog or any other literature published by TEMPCO are based on our own research and the research of others, and are believed to be accurate. We cannot anticipate all conditions under which this information and our products, or the products of other manufacturers in combination with our products, may be used.

We accept NO responsibility for results obtained by the application of this information or the safety and suitability of our products, either alone or in combination with other products. It is the responsibility of the Purchaser to make the ultimate choice of sheath material based on his/her knowledge of the chemical composition of the corrosive solution, character of materials entering the solution, and controls, which he/she maintains, on the process.



Recommended Sheath Materials

Media Being Heated	Element Sheath Material														*Notes				
	Iron & Steel	Gray Cast Iron	Cast Iron Ni-Resist	Aluminum	Copper	Lead	Monel 400	Nickel 200	304, 321, 347 Stn. Stl.	316 Stn. Stl.	Type 20 Stn. Stl.	Incoloy® 800	Inconel® 600	Titanium		Hastelloy B	Quartz	Graphite	Teflon®
Tetrachlorethylene	F	F		C	F	F	A	A	F	F	F	F	A	A		A			
Therminol™ FR1 8-12 W/Sq. In. 640°F	A																		
Thermoil Granodine™	F																		
Tin (Molten)	F	F		X	X	X	X	X	F	F	X		X	A			X	X	Note 4
Tin - Nickel Plating																A		A	Note 1
Tin Plating - Acid																	A	A	Note 1
Tin Plating - Alkaline	A								A										Note 1
Toluene	A	A	A	A	C	A	A	A	A	A	A	A	A	A					
Triad Solvent	C																		
Trichloroethane	A	C	C	F	F	F	F	F	A	F	F	F	F	A		A	A		
Trichloroethylene	F	C	C	F	C	X	C	C	F	F	F	F	A	A		A	A		
Triethylene Glycol	A	A	A	A	A	A	A	A	A	A	A	A	A	A		A			
Trioxide (Pickle)																A		A	Note 1
Trisodium Phosphate	A	A		X	C	X	C	C	C	C	C					X	F	X	
Turco™ 2623	A																		
Turco™ 4008, 4181, 4338										A									Note 1
Turco™ Ultrasonic Solution										A									Note 1
Turpentine	C	C	C	A	F	A	A	A	A	A		A							
Ubac™																A			Note 1
Udylite #66													A		A		A		Notes 1, 5
Unichrome™ CR-110															A		A		Note 1
Unichrome™ 5RHS															A		A		Note 1
Urea Ammonia Liquor 48°F	A																		
Vegetable Oil	C		C	F	X	X	A	A	A	A	A	A							
Vinegar	C			C			A		F	A									
Water, Acid Mine Containing Oxidizing Salts	X		C	C	C	C	X	C	A										
No Oxidizing Salts	C		A	A			A		X										
Water, Deionized	X	X		X	X		A	A	A	A	A	A	A						Note 10
Demineralized	X	X		X	X		A	A	A	A	A	A	A						Note 10
Distilled	X	X			X	X	C	A				A	A						Note 10
Potable	X	C	A	A	A	X	A	A	C	F	A	A	A	A		A			
Return Condensate	A		A	A	A	A			A	A	A	A							
Sea	X	X	A	X	X	A	A		C	C	A	F	F	A		A	A		
Watt's Nickel Strike																A			Note 1
Whiskey and Wines	X		C		A		A	A	A	A	A	A							Note 2
Wood's Nickel Strike																A			Note 1
Yellow Dichromate										A						A			Note 1
X-Ray Solution									A										
Zinc (Molten)				X	X	X	X	X	X	X	X	X	X	X				X	
Zinc Chloride	C	C	C	X	X		F	F	X	X	F	X	F	C		A	A	A	
Zinc Phosphate										A								X	Notes 1, 5
Zinc Plating Acid																A			Note 1
Zinc Plating Cyanide	A								A										Note 1
Zinc Sulphate	C	X	A	C	F	A	F	C	C	C	C		F	A					
Zincate™	A								A										Note 1

Corrosion Resistance Ratings:

A = Good **F = Fair** **C = Depends on Conditions** **X = Unsuitable**
Blank = Data Not Available

* See Key to Notes in Material Selection Guide on Page 16-12.

View Product Inventory @ www.tempco.com

Frequently Used Conversion Factors

U.S. Customary
1 cu. ft. = 1728 cu. in. = 0.03704 cu. yd.
1 cu. ft. = 7.481 gal.
1 gal. = 231 cu. in. = 0.1337 cu. ft.
1 gal. water = 8.3 lbs.
1 cu. ft. Water = 62.43 lbs.
1 KWH. will evaporate 3.5 lb. of water at 212°F
1 KWH. will raise 22.75 lb. of water from 62°F to 212°F
3412 BTU = 1 KWH = 1.34 HP Hour
1 HP = 745.7 Watts
1 BTU = 252 calories = 0.293 Watt Hours

Metric
1 in. = 2.54 cm = 25.4 mm
1 ft. = 0.3048 m
1 m = 39.37 in.
1 sq. in. = 6.4516 sq. cm.
1 sq. ft. = 0.0929 sq. m.
1 cu. in. = 16.39 cu. cm
1 cu. ft. = 0.02832 cu. m. = 28.32 liters
1 lb. = 453.6 grams
1 gal. (U.S.) = 3.785 liters
1 liter = 61.024 cu. in.

TO CONVERT	INTO	MULTIPLY BY
Atmospheres	Cms of Mercury	76
Atmospheres	Feet of Water (at 4°C)	33.9
Atmospheres	Inches of Mercury (at 0°C)	29.92
Atmospheres	Kgs/Square Cm	1.0333
Atmospheres	Kgs/Square Meter	10.332
Atmospheres	Pounds/Square Inch	14.7
BTU/Hour	Watts	0.2931
BTU/Minute	Horsepower	0.02356
BTU/Minute	Kilowatts	0.01757
BTU/Minute	Watts	17.57
Centiliters	Ounces Fluid (U.S.)	0.3382
Centimeters	Feet	3.281 × 10 ⁻²
Centimeters	Inches	0.3937
Cubic Centimeters	Cubic Feet	3.531 × 10 ⁻⁵
Cubic Centimeters	Cubic Inches	0.06102
Cubic Centimeters	Gallons (U.S. Liquid)	2.642 × 10 ⁻⁴
Cubic Feet	Cubic Cms	28.320
Cubic Feet	Cubic Inches	1,728
Cubic Feet	Cubic Yards	0.03704
Cubic Feet	Gallons (U.S. Liquid)	7.48052
Cubic Inches	Cubic Cms	16.39
Cubic Inches	Cubic Feet	5.787 × 10 ⁻⁴
Cubic Inches	Gallons	4.329 × 10 ⁻³
Cubic Inches	Cubic Feet	35.31
Cubic Meters	Cubic Yards	1.308
Cubic Meters	Gallons (U.S. Liquid)	264.2
Feet	Centimeters	30.48
Feet	Kilometers	3.048 × 10 ⁻⁴
Feet	Millimeters	304.8
Feet of Water	Atmospheres	0.0295
Feet of Water	Inches of Mercury	0.8826
Feet of Water	Pounds/Square Foot	62.43
Feet of Water	Pounds/Square Inch	0.4335
Gallons	Cubic Cms	3,785
Gallons	Cubic Feet	0.1337
Gallons	Cubic Inches	231
Gallons	Cubic Meters	3.785 × 10 ⁻³
Gallons	Cubic Yards	4.951 × 10 ⁻³
Gallons (Liquid Br. Imp.)	Gallons (U.S. Liquid)	1.20095
Gallons of Water	Pounds of Water	8.3453
Gallons/Minute	Cubic Feet/Hour	8.0208

TO CONVERT	INTO	MULTIPLY BY
Grams	Pounds	2.205 × 10 ⁻³
Horsepower	Kilowatts	0.7457
Horsepower (Boiler)	BTU/Hour	33479
Horsepower (Boiler)	Kilowatts	9.803
Inches	Meters	2.540 × 10 ⁻²
Inches of Mercury	Atmospheres	0.03342
Inches of Mercury	Feet of Water	1.133
Inches of Mercury	Pounds/Square Inch	0.4912
Kilograms	Pounds	2.205
Kilograms/Cubic Meter	Pounds/Cubic Feet	0.06243
Kilowatt Hours	BTU	3412
Liters	Cubic Feet	0.03531
Meters	Feet	3.281
Meters	Yards	1.094
Microns	Meters	1 × 10 ⁻⁶
Millimeters	Feet	3.281 × 10 ⁻³
Millimeters	Inches	0.03937
Ounces	Pounds	0.0625
Radians	Degrees	57.3
Radians	Minutes	3.438
Square Feet	Square Inches	144
Square Feet	Square Yards	0.1111
Square Inches	Square Cms	6.452
Square Inches	Square Feet	6.944 × 10 ⁻³
Square Meters	Square Feet	10.76
Square Meters	Square Yards	1.196
Square Yards	Square Feet	9
Square Yards	Square Inches	1,296
Square Yards	Square Meters	0.8361
Watts	BTU/Hour	3.4129
Watts	Foot-Pounds/Minute	44.27
Yards	Kilometers	9.144 × 10 ⁻⁴
Yards	Meters	0.9144

Area and Volume Formulas

Circle

$$D = 2R$$

$$C = 2\pi R = \pi D$$

$$A = \pi R^2 = \frac{\pi D^2}{4}$$

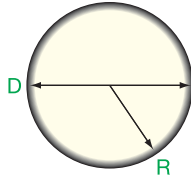

Rectangle

$$A = L \times W$$

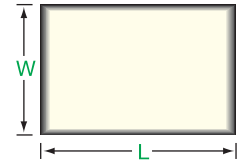

Circular Ring

$$A = \pi (R^2 - r^2)$$

$$= 0.7854 (D^2 - d^2)$$

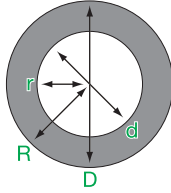

Parallelogram

$$A = L \times H$$

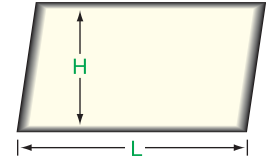

Ellipse

$$A = \pi \times A \times B$$

$$C = \pi \sqrt{2(A^2 + B^2)}$$

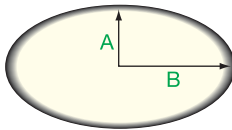

Trapezoid

$$A = \frac{(L1 + L2) H}{2}$$

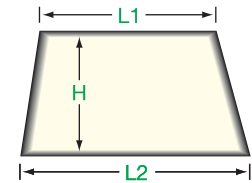

Sector

$$A = \frac{\pi R^2 \alpha}{360} = \frac{RL}{2}$$

$$L = \frac{\pi R \alpha}{180} = \frac{2A}{R}$$

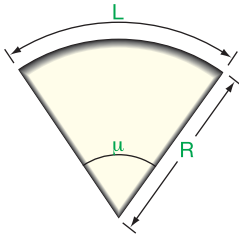

Rectangular Solid

$$A = 2(WL + LH + HW)$$

$$V = W \times L \times H$$

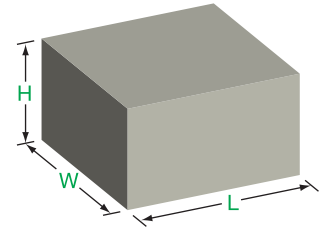

Sphere

$$A = 4\pi R^2$$

$$V = \frac{4\pi R^3}{3}$$

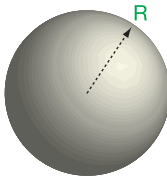

Triangle

$$A = \frac{B \times H}{2}$$

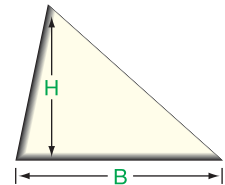

Cylinder

$$A = 2\pi R (R + H)$$

$$V = \pi R^2 H$$

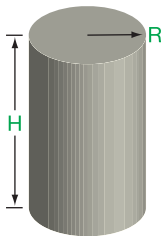

Hexagon

$$S = R = 1.155r$$

$$A = 2.598 S^2$$

$$= 3.464 r^2$$

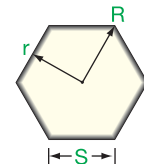

Cone

$$A = \pi R \sqrt{R^2 + H^2}$$

$$V = \frac{\pi R^2 H}{3}$$

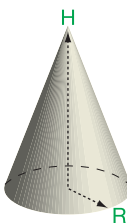

Regular Polygon

$$A = \frac{NSr}{2} = \frac{NS}{2} \sqrt{R^2 - \frac{S^2}{4}}$$

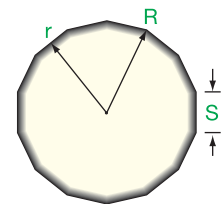

A = Area
V = Volume
 π = 3.1416

C = Circumference
R = Radius

D = Diameter
S = Length of side

N = Number of sides
 α = Angle

Fractional, Decimal and Millimeter Equivalents

	Decimals	Millimeters		Decimals	Millimeters	mm	inches	mm	inches		
	$\frac{1}{64}$.015625	0.397	$\frac{33}{64}$.515625	13.097		0.1	.0039	46	1.8110
	$\frac{1}{32}$.03125	0.794	$\frac{17}{32}$.53125	13.494		0.2	.0079	47	1.8504
	$\frac{3}{64}$.046875	1.191	$\frac{35}{64}$.546875	13.891		0.3	.0118	48	1.8898
$\frac{1}{16}$	$\frac{5}{64}$.078125	1.984	$\frac{9}{16}$.5625	14.288		0.4	.0157	49	1.9291
	$\frac{7}{64}$.109375	2.778	$\frac{19}{32}$.578125	14.684		0.5	.0197	50	1.9685
$\frac{1}{8}$	$\frac{9}{64}$.140625	3.572	$\frac{39}{64}$.609375	15.478		0.6	.0236	51	2.0079
	$\frac{11}{64}$.171875	4.366	$\frac{41}{64}$.640625	16.272		0.7	.0276	52	2.0472
$\frac{3}{16}$	$\frac{13}{64}$.203125	5.159	$\frac{21}{32}$.65625	16.669		0.8	.0315	53	2.0866
	$\frac{15}{64}$.234375	5.953	$\frac{43}{64}$.671875	17.066		0.9	.0354	54	2.1260
$\frac{1}{4}$	$\frac{17}{64}$.265625	6.747	$\frac{45}{64}$.703125	17.859		1	.0394	55	2.1654
	$\frac{19}{64}$.296875	7.541	$\frac{23}{32}$.71875	18.256		2	.0787	56	2.2047
$\frac{5}{16}$	$\frac{21}{64}$.328125	8.334	$\frac{47}{64}$.734375	18.653		3	.1181	57	2.2441
	$\frac{23}{64}$.359375	9.128	$\frac{49}{64}$.765625	19.447		4	.1575	58	2.2835
$\frac{3}{8}$	$\frac{25}{64}$.390625	9.922	$\frac{25}{32}$.78125	19.844		5	.1969	59	2.3228
	$\frac{27}{64}$.421875	10.716	$\frac{51}{64}$.796875	20.241		6	.2362	60	2.3622
$\frac{7}{16}$	$\frac{29}{64}$.453125	11.509	$\frac{13}{16}$.8125	20.638		7	.2756	61	2.4016
	$\frac{31}{64}$.484375	12.303	$\frac{27}{32}$.84375	21.431		8	.3150	62	2.4409
$\frac{1}{2}$.5000	12.700	$\frac{55}{64}$.859375	21.828		9	.3543	63	2.4803
				$\frac{57}{64}$.890625	22.622		10	.3937	64	2.5197
				$\frac{29}{32}$.90625	23.019		11	.4331	65	2.5591
				$\frac{59}{64}$.921875	23.416		12	.4724	66	2.5984
				$\frac{15}{16}$.9375	23.813		13	.5118	67	2.6378
				$\frac{61}{64}$.953125	24.209		14	.5512	68	2.6772
				$\frac{31}{32}$.96875	24.606		15	.5906	69	2.7165
				$\frac{63}{64}$.984375	25.003		16	.6299	70	2.7559
				1	1.000	25.400		17	.6693	71	2.7953
								18	.7087	72	2.8346
								19	.7480	73	2.8740
								20	.7874	74	2.9134
								21	.8268	75	2.9528
								22	.8661	76	2.9921
								23	.9055	77	3.0315
								24	.9449	78	3.0709
								25	.9843	79	3.1102
								26	1.0236	80	3.1496
								27	1.0630	81	3.1890
								28	1.1024	82	3.2283
								29	1.1417	83	3.2677
								30	1.1811	84	3.3071
								31	1.2205	85	3.3465
								32	1.2598	86	3.3858
								33	1.2992	87	3.4252
								34	1.3386	88	3.4646
								35	1.3780	89	3.5039
								36	1.4173	90	3.5433
								37	1.4567	91	3.5827
								38	1.4961	92	3.6220
								39	1.5354	93	3.6614
								40	1.5748	94	3.7008
								41	1.6142	95	3.7402
								42	1.6535	96	3.7795
								43	1.6929	97	3.8189
								44	1.7323	98	3.8583
								45	1.7717	99	3.8976
								100	1.8110	100	3.9370

1 mm = .03937"

.001" = .0254 mm

When You Know	Multiply by	To Find
Inches (in)	2.54	Centimeters (cm)
Feet (ft)	30.48	Centimeters (cm)
Yards (yds)	0.9	Meters (m)
Miles (mi)	1.6	Kilometers (km)



Prefix	Description	Section-Page(s)	Prefix	Description	Section-Page(s)
A					
APT	Alumina Protection Tubes	14-85	CSF	Finned Channel Strip Heaters	8-14, 8-15
ARA	Ceramic E-Mitter Radiant Panel Arrays	7-28	CSH	Channel Strip Heaters	8-8 to 8-11
ARC	Channel Strip Radiant Panel Arrays	8-10	CTL	Panel LED Indicators for Remote Current Transformers	12-56
ARG	Gemini Medium Wave Panel Arrays	7-69	CTR	Current Transformer Relay	12-57
ARK	Vitreous Silica Quartz Tube Panel Arrays	7-70	CTT	Current Sensing Transformers	12-56
ART	Tubular Radiant Heater Panel Arrays	7-85, 10-17	D		
ARV	KTE and KTG Heater Panel Arrays	7-48	DHB	Full Coverage Drum Blanket Heaters	11-125
ASF	Arctic-Cast Shroud	3-38	DHM	Drum Heater, Metal	11-122
ASJ	Cool TO-THE Touch Sheet Metal Shroud	3-30, 3-31		Heated Drum Dolly	11-122
	Multi-Versal Shroud	3-34	DHR	Drum Heater, Silicone Rubber	9-20; 11-120
B					
BCH	Ceramic Band	1- 63 to 1-65	DHX	Hazardous Area Rated Drum Heater, Silicone Rubber	9-21; 11-121
BLK	Insulation Blankets	15-17	DTA	Handheld Digital Thermometer Probes	12-60
BMT	Bimetal Dial Thermometer	12-54, 12-55	DTM	Portable 6-Station Temperature Monitor	12-52
				12-Station Temperature Monitor	12-53
				Handheld Digital Thermometers	12-60
C					
CAB	Armor Cable and Wire Braid	15-14	E		
CAC	Bulk Round Heater Cable Double Conductor	5-25	ECA	Thermocouple Cable Assemblies	12-28; 14-9
CAS	Bulk Round Heater Cable Single Conductor	5-24	ECR	RTD Extension Assemblies	14-64
CAW	Bulk Round Heater Cable Double Conductor	5-25	EHA	Remote Thermostats for Enclosure Heaters	7-41; 9-18; 11-115
CBH	Cool TO-THE Touch Cast-In Heaters	3-30, 3-31	EHC	Ceramic E-Mitter® Enclosure Heaters	7-41
	Multi-Versal Cast-In Heaters	3-34	EHD	Electrical Plugs & Connectors	
	Arctic-Cast Cast-In Heaters	3-38			1-22, 1-48; 2-56; 7-17, 7-84; 15-14, 15-15
	Finned Cast-In Heaters	3-45, 3-46		Ceramic Twist-Loc Wire Connectors	7-20; 15-10
	Liquid Cooled Cast-In Heaters	3-58 to 3-62		Terminal Blocks	7-21, 7-22, 15-10 to 15-12
	“L” Shaped Cast-In Heaters	3-65		Bulb & Capillary Thermostat Pilot Lamp	11-6 to 11-8
	Cast-In Ring Heaters	3-68		Pilot Lamps	11-6 to 11-8; 13-76 to 13-78
	Cast-In Cross Head Die Heaters	3-69	EHDR	High Temperature Electrical Cup Assembly	15-14
	Cast-In Platen Die Heaters	3-71	EHF	Finned Channel Strip Enclosure Heaters	8-15
CER	Igloo Ceramic Covers	1-15, 1-33, 1-69; 8-7, 8-13; 15-13	EHR	Silicone Rubber Enclosure Heaters	9-18
	Thermocouple Insulators	14-96	EHT	Tubular Enclosure Heaters	11-115
	Ceramic Beads	7-23, 15-13	EMM	Megohmmeter/Insulation Tester	12-59
CERR	Insulated Bushing Assembly	8-13, 15-13	EMT	Temperature/Process Indicators	12-50
CFR	Ceramic Putty	4-3	EMV	Digital Multimeter	12-58
	Ceramic Fiber Heaters	4-6 to 4-8		Clamp-On Multimeter	12-58
CHF	Circulation Heaters	11-52 to 11-70		AC Line Separator/Splitter	12-59
CHS	Circulation Heater Systems	11-71	ERD	Extruder Rupture Disks	12-29
CHX	Cast Aluminum Circulation Heater Systems	3-12, 3-14, 3-16	ETM	Electronic Transmitters, Miniature	12-44, 12-45
CML	Cartridge Heater Coating	2-7	ETR	Electronic Transmitters, Rail Mount	12-46, 12-47
CON	Connectors	7-23	F		
COR	Thermocouple Insulators	14-96	FAH	Flanged Aluminum Finned Immersion Heaters	11-21
CRA	Ceramic Infrared E-Mitter® Linear Heater Assemblies	7-16	FAS	Linear Housing Mounting Bolts	7-76 to 7-81
	Gemini Linear Heater Assemblies	7-68		Tubular Heater Mounting Collars	10-7
CRB	Ceramic Infrared E-Mitter®, Curved	7-4, 7-16		Plastic Melt Bolts	14-101
CRC	Ceramic Infrared E-Mitter®, Curved	7-7, 7-16	FHA	Rope Foil Heater	9-23
CRD	Ceramic Infrared E-Mitter®, Flat Face, Long Shaft	7-11	FLG	Fittings for Metal Tubes	14-88
CRE	Ceramic Infrared E-Mitter®, Bulb Style	7-39	FTF	Flexible Heating Tape (Fiberglass)	9-29
CRG	Ceramic Infrared E-Mitter®, Flat Face, Short Shaft	7-9		Silicone Rubber Insulated Flexible Heating Tape	9-30
CRH	Ceramic Infrared E-Mitter®, Flat Face, Short Shaft	7-11		Silicone Rubber Heating Tapes with Controls	9-31
CRK	Ceramic Infrared Accessories	7-14	FTG	Cooling Tube Fittings	3-21, 3-52
	Standard Linear Housings	7-19		Hose Fittings	3-53
	E-Mitter® Reflectors	7-20		Protection Tube Mounting Parts	14-88
	Edison Screw-In Base	7-38, 7-40		Sensor Mounting Fittings	14-88, 14-89
	Quartz Lamp Accessories	7-57	FTP	Adhesive Backed Heating Tape	9-27
	Gemini Clamp Assemblies	7-67	G		
CRL	Ceramic Infrared E-Mitter®, Curved	7-3, 7-25, 7-27	GEM	Gemini® Series Radiant Heaters	7-66, 7-68
CRM	Ceramic Infrared E-Mitter®, Curved	7-6	GLS	Replacement Glass	7-27
CRN	Ceramic Infrared E-Mitter®, Flat Face, Short Shaft	7-13	GRD	Replacement Motor Guard	3-41
CRP	12" x 12" Modular Panels	7-25, 7-27		Replacement Protective Wire Guard	
CRR	Ceramic Infrared E-Mitter®, Round Flat Face	7-39			7-56, 7-72, 7-73, 7-76 to 7-81
CRS	Ceramic Infrared E-Mitter®, Curved	7-8			
CRT	Ceramic Infrared E-Mitter®, Tube Shaped	7-40, 7-41			
CRZ	Ceramic Infrared E-Mitter®, Flat Face, Short Shaft	7-13			



Prefix	Description	Section-Page(s)	Prefix	Description	Section-Page(s)
H					
HAC	Forced Air Heater	11-76	MSH	Mica Strip Heaters	8-24, 8-25
HDB	Bolt Heaters	2-62	MTA	Mineral Insulated Thermocouple Assemblies	7-95; 14-15 14-17, 14-19 to 14-26
HDC	Hi-Density Cartridge (English sizes)	2-10, 2-14 to 2-22	MTC	Mineral Insulated Thermocouple Cable	14-119 to 14-123
	Hi-Density Underwater Pelletizer Die Heater	2-27	MTR	Forced Air Blowers	3-41, 3-42
HDL	Hi-Density Cartridge Liquid Immersion	2-23	MXB	Maxiband® (Heat & Cool)	1-91, 1-92
HDM	Hi-Density Cartridge (Metric sizes)	2-31 to 2-33	MXC	Maxiband® (Cool only)	1-93, 1-94
HDP	Hi-Density Pennybottom™ Cartridge	2-25, 2-26	MXH	Maxiband® (Heat only)	1-82 to 1-86
HEH	Heated Hoses	11-117	MXS	Maxistrip® Heaters	8-18, 8-19
HET	Heated Tubing Assemblies	11-118	N		
HHC	Rectangular Cable Heaters (Coiled)	5-11, 5-12	NHB	Cast Nozzle Bronze Heater Bushings	5-28
	Square Cable Heaters (Coiled)	5-14	NHL	Nozzle Band Heater (Type L Termination)	1-52
	Oxygen Analyzer Heater	5-15	NHW	Nozzle Band Heater (Type W Termination)	1-53
HHF	Oxygen Analyzer Heater	5-15	NTS	Irreversible Temperature Indicators	15-18
HHS	Round Straight Tempco-Pak® Heater without T/C	5-21	P		
	Square Straight Tempco-Pak® Heater without T/C	5-22	PCE	Power Temperature Control Panels, Solid State Relay	13-59
	Rectangular Straight Tempco-Pak® Heater without T/C	5-23	PCM	Pre-Wired Power Control Boxes	13-55
HRN	Hot Runner Mini-Coil Heater without T/C	5-27		Power Temperature Control Panels, Mechanical Contactors	13-59
	Gamma Series Dual Sleeve Mini-Coil Heater without T/C	5-30	PCS	Power Temperature Control Panels, SCR	13-59
HRY	Hot Runner Mini-Coil Heater with T/C	5-27	PCT	Tote Tank/IBC Replacement Controller	11-128
HSC	Infinite Heat Switch	13-51		Thermostat & Temperature Controllers	13-54
HSGR	Bulb & Capillary Thermostat Enclosures	11-9, 13-79	PDA	Melt Pressure Accessories and Electronics	12-26 to 12-28
	General Purpose Terminal Boxes	15-15	PDD	Melt Pressure Transducers	12-22, 12-23
HTP	KE Style Constant Wattage Heat Trace Cable	6-8	PDG	Melt Pressure Gauges	12-25
	FE Style Constant Wattage Heat Trace Cable	6-9	PPR	Paperless Chart Recorders and Accessories	12-7
	Constant Wattage Heat Trace Cable Lead Termination Kits	6-10	PPT	Porcelain Protection Tubes	14-85
	Self-Limiting Heat Trace Cable	6-12	Q		
	Heat Trace Cable Controls and Accessories	6-13	QRH	Quartz Lamp Radiant Heater Assemblies	7-56
	Closed Cell Elastomeric Thermal Insulation	6-14	R		
J					
JP_	Jack Panel Assemblies (Blank is for T/C Calibration)	14-69 to 14-72, 14-74	RCA	Chart Recorders Accessories	12-9, 12-11
K					
KMH	Chemical Tank Immersion Heaters	11-103 to 11-102	RCR	Pen Chart Recorders	12-9, 12-11
KRD	Vitreous Silica Quartz Tube	7-71 to 7-73	REB	Infrared Electronics BAT and Accessories	12-30 to 12-33
KRH	Linear Vitreous Silica Quartz Tube Heaters	7-72, 7-73	REN	NCIT-LC Plus Series Infrared Noncontact Temperature Measurement System	12-35
KTE	Quartz Tube E-Mitters	7-44, 7-45		NCIT-LC Advanced Series Infrared Noncontact Temperature Measurement System	12-37, 12-38
KTG	Quartz Tube E-Mitters	7-44, 7-45		NCIT-LLC Series Infrared Noncontact Temperature Measurement System	12-39
L					
LDA	In-Line Air Process Heaters	11-75	RES	Resistance Wire	15-6 to 15-9
LDC	Low Density Cartridge	2-35 to 2-38	RHR	Rope Heater	9-25
LDW	High Temperature Lead Wire	7-23	RLM	DIN Rail Mounted Mechanical Relay	13-95
	RTD Multiconductor Wire	14-112		IEC Style Enclosed Contactors	13-96
LDWR	Spoiled High Temperature Lead Wire	15-2	RLS	Solid State Relays	13-88 to 13-90
	Spoiled PTFE Lead Wire	15-3	RLY	Mercury Relays	13-92 to 13-94
LMP	Sealed IR Quartz Lamps	7-54, 7-56	RPB	Radiant Panel, Black Face	7-90
	Sealed IR Quartz Lamps Mounting Clamp	7-57	RPG	Radiant Panel, High Temperature Glass	7-91
	Replacement VS Glow Lamps	7-59, 7-60	RPM	Radiant Panel, Metal Face	7-93
M					
MBH	Duraband® (Mica Band)	1-54 to 1-59	RPW	Radiant Panel, Very High Temperature Ceramic Glass	7-92
MER	Rotating Connector	12-13 to 12-16	RTD	Resistance Temperature Detectors	14-50 to 14-58
MHC	Mightyband™ Round Cable Heaters (Coiled)	5-6 to 5-9	RTM	RTDs with Transmitter and Connection Head	14-59
	Mightyband™ Square Cable Heaters (Coiled)	5-10, 5-11, 5-14	RTP	RTDs for the Plastics Industry	14-61 to 14-63
	Mightyband™ Rectangular Cable Heaters (Coiled)	5-12, 5-13	RTS	Melt Bolt RTDs	14-65
MHS	Round Straight Tempco-Pak® Heaters with T/C	5-21		Sanitary RTDs	14-60
	Square Straight Tempco-Pak® Heaters with T/C	5-22			
	Rectangular Straight Tempco-Pak® Heaters with T/C	5-23			
MPP	Mineral Insulated Band	1-7, 1-8			
MPT	Thermowells	11-10; 13-80; 14-86			





Continued from previous page...

Prefix	Description	Section-Page(s)	Prefix	Description	Section-Page(s)
S					
SCW	Screws	7-21, 7-76 to 7-81	TCW	Thermocouple Wire	7-23; 14-107 to 14-111
SEA	RTV Adhesive	9-12		Coil Cord for Thermocouples & RTDs	14-112
	Heat Transfer Cement	10-13	TCWR	Spooled Type J Thermocouple Wire	14-107; 15-4
SHK	Kapton® Heaters (Rounds)	9-8		Spooled Type K Thermocouple Wire	14-108; 15-4
	Kapton® Heaters (Squares & Rectangles)	9-8		Spooled Type JX Thermocouple Extension Wire	14-110; 15-4
SHS	Silicone Rubber Heaters (Rounds)	9-6		Spooled Type KX Thermocouple Extension Wire	14-110; 15-4
	Silicone Rubber Heaters (Squares & Rectangles)	9-7	TDH	Duct Heaters	11-113
	PVC Pipe/Conduit Bending Heaters	9-17	TEB	Thermostat (Conduction Type Surface Mount)	13-81
	Composite Curing Flexible Heating Blankets	9-19	TEC	Replacement Motor Capacitor	3-41
	Tote Tank/IBC Replacement Heater	11-128		Memory Card for Videographic Data Logger	12-7
SLV	Fiberglass Sleeving	7-23; 15-14		Temperature Controllers	13-5 to 13-41
SMP	End Plates	7-76 to 7-81		Temperature Controller Accessories	13-47 to 13-49
SMPR	Replacement Reflector	7- 56, 7-72, 7-73, 7-76 to 7-81	TER	Terminal Lugs	7-23; 15-18
SPR	Mounting Clips	7-14	TEV	Thermostat (Expansion Type Cartridge)	13-86
SRS	Solid State Variable Power Controller	13-67	TFP	Flanged Heaters (Pressure Rated)	11-32 to 11-44
	SCR Single Phase	13-71, 13-72	THE	Tubular Heaters	7-76 to 7-81, 7-86, 7-87; 10-14, 10-15
	Potentiometer Kit for SCRs	13-71 to 13-75	THF	Finned Tubular Heaters	10-16 to 10-16M
	Multi-Tap Transformer for SCRs	13-71, 13-73	THR	Tubular Rope Heaters	9-25
SRT	SCR Three Phase	13-73 to 13-75	TKA	Hot Runner Controls	13-64 to 13-66
STS	Special Application Temperature Sensors	14-67	TKZ	Encapsulated Temperature Controllers	13-50
ST1	Transition to Lead Wire Thermocouple (Stock)	14-14	TMB	Melt Bolt Thermocouples	14-10, 14-11
ST2	Plug Termination Thermocouple (Stock)	14-16	TMC	Replacement Thermal Protection Accessories	11-86, 11-87
ST4	Stripped Cold End Thermocouple (Stock)	14-18	TMM	Chemical Tank Immersion Heaters	11-98 to 11-102
ST6	Connection Head with 1/2" NPT Hex Nipple (Stock)	14-22	TMT	Chemical Tank Immersion Heaters	11-90 to 11-97
T					
TAP	Fiberglass Tape	15-18	TMW	Magnet Thermocouples	14-8
TAT	Over-the-Side Immersion Heaters	11- 78, 11-79	TNB	Tubular Nozzle Band	1-79
	Reservoir Water Heaters	11- 80	TNW	Nozzle Style Thermocouples	14-7, 14-42
	Vertical Loop Immersion Heaters	11- 81	TPC	Benchtop Temperature Control Consoles	13-53
	Sanitizing Sink Immersion Heaters	11- 81	TPN	Flanged Heaters (Custom)	11-22 to 11-25
	Deep Tank Immersion Heaters	11-83	TPW	Pipe Clamp Thermocouples	14-7
	Drum Immersion Heaters	11-123	TRH	Tubular Infrared Heater Universal 2000®	7-76 to 7-81
TBC	Model TBC-41 Board PID Temperature Control	13-42, 13-43	TRW	Ring Lug Thermocouples	14-6
TBS	Screw Terminal Barrier Blocks for Thermocouples	14-101	TSP	Screw Plug Heaters	11-11 to 11-19
TCA	Thermocouple Mating Connector	12-28	TST	Bulb & Capillary Thermostats	11-6 to 11-8; 13-76 to 13-78
	Thermocouple & RTD Selector Switch	14-73		Bulb & Capillary High Limits with Manual Reset	11-10; 13-80
	Circular Panel Jacks	14-73		Stuffing Box Assembly	11-10; 13-80
	Panel Jacks	14-75		Surface Mount 1/2" Disc Thermostats	13-82
	Bayonet Adapters	14-87		High Limit Surface Mount Disc Thermostats	13-83
	Quick Disconnect Plugs & Jacks	14-90, 14-91		Thermal Cutoffs	13-84
	Accessories for Plugs & Jacks	14-92 to 14-95	TSW	Shim Stock Thermocouples	14-6
	Die Cast Aluminum Heads	14-98	TSTR	Thermostat Kits	11-7; 13-77
	Type "H" Standard Cast Iron Heads	14-99	TTM	Thermocouples with Transmitter & Connection Head	14-27
	Bakelite Heads	14-99	TTR	Thermistors	14-66
	Polypropylene Heads	14-100	TTW	Tube & Wire Thermocouples	14-2
	Stainless Steel Heads	14-100	TUB	Cooling Line Tubing	3-53
	Miniature Nickel-Plated Steel Head	14-100	TUL	Optional Ratchet Screwdriver	14-72
	Spring-Loaded Terminal Blocks	14-100	TWL	Thermowells	14-77 to 14-83
TCB	Base Metal Thermocouples	14-37, 14-38	TWW	Wire Thermocouples	14-8
TCH	Pipe Clamp Adapters for Bayonet Type Thermocouples	14-87	V		
	Open Disc Terminal Blocks	14-97	VSA	VS Glow Lamp	7-59
	Die Cast Aluminum Heads with Terminal Blocks	14-98	VSC	VS Glow Lamp	7-60
	Bakelite Heads with Terminal Blocks	14-99	VSR	VS Glow Lamp	7-61
TCM	Multipoint Thermocouples	14-28	W		
TCN	Noble Metal Thermocouples	14-39	WAS	Washers	7-21, 7-22; 15-12
TCP	Replacement Thermocouples for Panel Heaters	7-95	WCT	Wraparound ToteTank/IBC Heaters	11-127
	Thermocouples for Plastics Industry	14-3 to 14-5		ToteTank/IBC Silicone Rubber Heater Pad & Control	11-128
	OEM Replacement Thermocouples	14-41, 14-42	WHT	Water Hose, Teflon®	3-53
	Special Application Thermocouples	14-68	WIR	Bare Wire	7-23
TCR	OEM Replacement T/C's	5-12; 14-40; 14-43 to 14-45			
TCS	Industrial Process T/C's	14-33 to 14-36			



ACCEPTANCE

- A. All orders are accepted in accordance with the Terms and Conditions set forth below.
- B. For all purchase orders received by TEMPSCO, whether they be via the telephone, telefax or in writing, the customer acknowledgment you receive will act as the official document of acceptance of your purchase order. All information typed or printed (description, prices, etc.) on the acknowledgment will be assumed to be correct. This information will override any previous correspondence in writing or telephone conversations. If a discrepancy is found you will have 5 days from the date typed or printed in the box "DATE ENTERED" to bring it to the attention of TEMPSCO. Once we have been notified, and if a change is necessary, you will receive a corrected acknowledgment from TEMPSCO.
- C. Following acceptance by TEMPSCO, orders are not subject to cancellation or modification, except upon written approval by TEMPSCO and shall be subject to cancellation charges as determined by TEMPSCO.

*TEMPSCO RESERVES THE RIGHT TO CORRECT
AND AMEND ANY TYPOGRAPHICAL ERRORS.
APPLICABLE CURRENCY US DOLLARS ONLY.*

ASSIGNMENT

Purchaser shall not assign or transfer this contract or any interest in it, or monies payable under it, without the written consent of TEMPSCO, and any assignment made without such consent shall be null and void.

CANCELLATIONS & PENALTIES

Should the Purchaser decide, for whatever reason to cancel an acknowledged order that has not yet shipped, the following criteria will be applied for disposition of the order:

1. If the product in question is determined to be stock product, such determination to be made solely by TEMPSCO, the Purchaser will be assessed a penalty equal to 10% of the dollar amount of the order plus all other related costs and processing fees. Such penalty shall be immediately due and payable upon order cancellation. Any and all prepayments made to TEMPSCO will be applied toward such penalty and costs.
2. If the product in question is determined to be non-stock (i.e. custom or modified stock), such determination to be made solely by TEMPSCO, Purchaser will reimburse TEMPSCO for all costs incurred as of the date of cancellation with respect to such product, including but not limited to engineering, design and development costs, material costs, freight costs, manufacturing labor and overhead costs, inventory costs, processing fees plus all other costs related to the cancelled order. Such penalty shall be solely determined by TEMPSCO and shall be immediately due and payable upon order cancellation. Any and all prepayments made to TEMPSCO will be applied toward such reimbursements of costs. Purchaser must notify TEMPSCO of intent to cancel in written form within five (5) days of verbal communication.

CORROSION POLICY

TEMPSCO cannot warrant any electric immersion heater against failure by sheath corrosion if such failure is the result of operating conditions beyond the control of the heater manufacturer. The facts and recommendations appearing in the TEMPSCO catalog or any other literature published by TEMPSCO are based on our own research and the research of others, and is believed to be accurate. We cannot anticipate all conditions under which this information and our products, or the products of other manufacturers in combination with our products may be used. We accept NO responsibility for results obtained by the application of this information or the safety and suitability of our products, either alone or in combination with other products. It is the responsibility of the Purchaser to make the ultimate choice of sheath material based on his/her knowledge of the chemical composition of the corrosive solution, character of materials entering the solution, and controls, which he/she maintains, on the process.

CREDIT CONDITIONS

Credit shipments on an open account basis will be made to approved Purchasers who maintain a good credit rating. Purchasers whose credit has not been approved by TEMPSCO will be required to complete a credit application for open account consideration. Shipment of products to unapproved Purchasers will be either Cash In Advance, C.O.D. or Credit Card.

CREDIT TERMS

In God we trust; all others must pay cash. Where credit has been approved by TEMPSCO, Terms of Sale are strictly Net 30 days from date of invoice for all products sold with the exception of the products noted in the paragraph that immediately follows.

For all sales of power control panels of 30 amps or higher, terms are 1/3 payment with purchase order, 1/3 payment received prior to shipment, and 1/3 payment Net 30 days. Such terms for these products shall apply where credit has been approved by TEMPSCO.

All prices are F.O.B. Factory, Wood Dale, Illinois, U.S.A., in U.S. Dollars only. TEMPSCO reserves the right to select means of shipment, consistent with least cost and commensurate service. Prices do not include any city, county, state, or federal taxes imposed upon the sale. Finance charges at the rate of 1 and 1/2% per month shall be charged to all accounts that are unpaid after 30 days or other described due date. Buyer shall be responsible for all costs of collection including reasonable attorney fees.

TEMPSCO also accepts VISA, Master Card, Discover and American Express Credit Cards.

DELIVERY, TITLE AND RISK OF LOSS

Delivery dates are approximate and are based upon prompt receipt of all necessary information from Purchaser. Unless otherwise specified by TEMPSCO, delivery will be made and title will pass F.O.B. point of shipment to Purchaser.

DESIGN CHANGE

The policy of TEMPSCO is one of continuous development and product improvement, and we reserve the right to modify specifications, designs and materials without prior notice and without incurring any obligations or liabilities.

ENGINEERING CHARGE

On complex heating or control systems an engineering charge may be applied to the first order only. If similar items are ordered later, the engineering charge is generally dropped from these items after the first charge has been paid. This charge is not subject to discount.

EXCUSABLE DELAYS

TEMPSCO will notify Purchaser of any material delay and will specify the revised delivery date as soon as possible. TEMPSCO shall not be liable for delays in delivery or for failure to manufacture, or failure to perform due to: acts of God, fire, flood, wind, war, sabotage, civil unrest, disobedience, accidents, government priorities, strikes, or any other causes beyond TEMPSCO'S control, such determination to be made solely by TEMPSCO.

GENERAL

The Terms and Conditions on this page shall, unless otherwise specifically agreed to by TEMPSCO in writing, be the Terms and Conditions governing any purchase and sales contract entered into between the Purchaser and TEMPSCO. Stenographic and clerical errors are subject to correction. No modification of, or addition to, or waiver of any of the Terms and Conditions hereof will be effective unless agreed to in writing by TEMPSCO.

GOVERNING LAWS

These Terms and Conditions of Sale and all dealings between TEMPSCO and the Purchaser and/or recipient of goods and/or the appointed representative(s) acting on behalf of the Purchaser and/or recipient shall be governed by, construed and enforced in accordance with the laws of the United States and the State of Illinois as it applies to a contract/purchase order made and performed in such state. The parties agree that the exclusive forum for any litigation relating to a contract/purchase order shall be the federal or state courts of the State of Illinois. The parties hereby expressly consent to the exclusive jurisdiction of the federal or state courts of the State of Illinois for any litigation relating to this transaction or any other contract/purchase order between the respective parties.

CONTINUED 



Continued from previous page...

INDEMNITY AND WAIVER OF SUBROGATION

Purchaser agrees to indemnify and hold TEMPCO harmless with respect to any third party claims for personal injury (or death), property damage or other loss which claims are based upon defective or allegedly defective design, material or workmanship furnished by TEMPCO. Purchaser represents that any liability insurance policies, which Purchaser may have, provide that subrogation rights against suppliers such as TEMPCO are waived.

MINIMUM ORDER CHARGE

TEMPCO has differing required minimum order values depending on the product type and whether the related product is considered stock or a non-stock/production item. Such minimum order values shall be communicated upon order placement.

ORDER CHANGES

Purchaser shall have the right, by giving written notice to TEMPCO, to make changes in the quantity, drawings, designs, or specifications for the articles to be manufactured. Upon receipt of any such notice, TEMPCO shall notify Purchaser as promptly as possible of changes in the price of, or the time required for performance of the order, and an equitable adjustment determined solely by TEMPCO shall be made in the contract price or delivery schedule, or both, prior to incorporating said changes into the manufactured article.

PATENT INDEMNITY

To the extent that items delivered hereunder are manufactured pursuant to detailed designs furnished by the Purchaser, Purchaser agrees to indemnify TEMPCO and hold TEMPCO harmless from all legal expenses which may be incurred as well as all damages and costs which may be finally assessed against TEMPCO in any action for infringement of any United States Letters Patent by such items delivered hereunder. TEMPCO agrees promptly to inform the Purchaser of any claim for liability made against TEMPCO with respect to such items and TEMPCO agrees to cooperate with Purchaser in every way reasonably available to facilitate the defense against such claim.

PATENT RIGHTS

To the extent that TEMPCO develops a new process while designing a new product on behalf of Purchaser, the rights to the new process and/or product including patent rights shall remain with TEMPCO.

PRICE ADJUSTMENTS AND SURCHARGES

Prices on all TEMPCO products are subject to adjustment at the time of shipment by means of an added surcharge or price adjustment based on the current cost of metals and/or other raw materials.

PRICING

Prices, discounts, delivery and designs are subject to change without notice. The price of any article scheduled for shipment on a date beyond a period of one year from the date of receipt of Purchaser's order, is subject to a price increase by TEMPCO, unless otherwise agreed to in writing. Prices include ordinary packaging only, unless otherwise specified.

PURCHASER'S PROPERTY

Where Purchaser had delivered to TEMPCO parts, equipment, material, jigs, fixtures, wiring or any other item for use by TEMPCO in manufacturing, processing, assembling or modification of products for Purchaser, the Purchaser's property shall be considered personal property and title and the right to possession shall vest in TEMPCO until all payments hereunder (including deferred payments, whether evidenced by notes or otherwise) are accomplished. Purchaser agrees to perform all acts necessary to perfect and maintain such right and title in TEMPCO. TEMPCO shall not be liable for loss or damage to Purchaser's property in its possession.

RESTOCKING CHARGES

Stock products as defined in the cancellations and penalties paragraph, which have not been used or modified, can be returned for a 20% restocking charge, with a minimum charge of \$50.00 net. Any and all returns must be received by TEMPCO within 90 days of customer receipt of the related product to be considered valid. All freight charges related to returned products shall be in addition to the noted restocking charges and shall be Purchaser's responsibility. Non-stock products as defined in the Cancellations and Penalties paragraph are NOT subject to return under any circumstances.

PLEASE NOTE: All returns must be accompanied by an RMA (Returned Material Authorization), obtained from TEMPCO.

RETURNS

No product shall be returned without the proper paperwork issued by TEMPCO. All returned material must be accompanied by an "RMA" (Returned Material Authorization). All unauthorized returns will be refused and returned to the Purchaser at the Purchaser's expense. All returns must be shipped freight prepaid.

SALES THROUGH REPRESENTATIVES

Unless specifically otherwise authorized in writing by TEMPCO, the representative shall have no authority to solicit or take orders for the sale of products covered by his Representative Agreement except at TEMPCO'S established prices and discounts, and in accordance with TEMPCO'S standard conditions of sale as set from time to time in TEMPCO'S published catalogs, price books, quotations, or printed forms. All sales made through the Representative hereunder shall be for direct shipment to Purchaser from TEMPCO'S factories or warehoused stock. The Representative shall have no authority to bind TEMPCO to any contract whatsoever. All orders obtained by the Representative are subject to acceptance by TEMPCO and no order or contract shall be binding upon TEMPCO until so accepted in writing by TEMPCO.

STOCK

Stock items as defined are shipped in exact quantities ordered. All other industrial heaters or related accessories are subject to the provisions of the paragraph titled "Variations in Shipping."

TOOLING, WOOD PATTERNS, AND PERMANENT MOLDS

Applicable customer charges for wood patterns, permanent molds and all other types of tooling represent only a portion of the total cost of the related tools, therefore TEMPCO retains ownership over said tooling. TEMPCO will maintain all tooling used to produce the Purchaser's heaters at no cost to Purchaser, except when the cost of repairing such tooling exceeds a reasonable amount solely determined by TEMPCO.

The cost associated with storing infrequently used tooling may become prohibitive. Tempco therefore reserves the right to dispose of said tooling at a time deemed appropriate by TEMPCO. If new tooling becomes necessary, it is the responsibility of Purchaser to pay a tooling charge. TEMPCO will accept Purchaser's special tooling at our plant, sent freight prepaid. See paragraph titled "Purchaser's Property".

UNLIKE PRODUCTS

- A. Cartridge Heaters, Mica Band, Mica Strip Heaters, and Thermocouples may be combined for maximum discount only if they are all purchased from stock.
- B. For all other products, only items within the same product line may be combined for maximum discount.

VARIATIONS IN SHIPPING

On orders for items carried in stock, TEMPCO will ship the exact quantity specified. However, in the manufacturing of our non-stock products, it is necessary to allow for losses in production and for this reason, we reserve the right to ship as stated below:

Units Ordered	Shipping Variations
1 - 5	No Variation
6 - 10	±1 Unit
11 - 25	±2 Units
26 - 49	±4 Units
50 and Over	±5%



WARRANTY

TEMPCO warrants that at the time of shipment, the products manufactured by TEMPCO and sold hereunder, will be free from defects in material and workmanship and will be in conformity with the applicable printed or written specifications. If it appears that within one (1) year of shipment from TEMPCO'S plant (two years after delivery to the first purchaser for use for TEC Temperature Controllers only), the products sold hereunder do not meet the warranty specified above, and the Purchaser gives written notice to TEMPCO thereof within thirty (30) days of Purchaser's discovery of such non-compliance, then after TEMPCO has examined and tested the allegedly non-complying product and found said to be, in fact, defective within the above warranty period, TEMPCO will at its option, either (A) furnish a replacement for but will not install, any product or components thereof which prove to be not in compliance with the aforesaid warranty, or, (B) issue a credit for the purchase price of any product or components thereof which prove to be not in compliance with the aforesaid warranty. TEMPCO'S liability in all circumstances shall not exceed the dollar amount of the related order. No product claimed by the purchaser to be defective within the above warranty will be accepted for return for replacement or credit without the written authorization (RMA) of TEMPCO, which authorization must be given in advance of Purchaser's return of said product.

THE FOREGOING WARRANTY IS IN LIEU OF ALL OF THE WARRANTIES EXPRESS OR IMPLIED, AND TEMPCO EXPRESSLY DISCLAIMS ALL OTHER WARRANTIES INCLUDING WITHOUT LIMITATION WARRANTIES IMPLIED UNDER LAW SUCH AS BUT NOT LIMITED TO WARRANTIES OF MERCHANTABILITY AND WARRANTIES OF FITNESS FOR A PARTICULAR PURPOSE. TEMPCO WILL NOT BE LIABLE FOR ANY SPECIAL, CONSEQUENTIAL, OR INCIDENTAL DAMAGES RESULTING FROM ITS BREACH OF THE FOREGOING WARRANTY.

TEMPCO will not be liable for any loss, damage, or expense directly or indirectly arising from the use of the products either separately or in combination with any other equipment or material or from any other cause. The foregoing warranty does not extend to any product manufactured by TEMPCO which has been subjected to misuse by Purchaser, neglect, accident, or improper installation; nor does the said warranty extend to or apply to any unit which has been repaired or altered by persons not expressly approved in writing by TEMPCO. Nor does the warranty extend to or apply to any product the identifying symbol of which has been removed, defaced, or changed. Components manufactured by any supplier other than TEMPCO, which are sold hereunder, shall bear only that warranty made by the manufacturer of those components; but in no event shall such a warranty be more extensive in any manner than TEMPCO'S product warranty errors, defects, or omissions in the design of any product sold hereunder irrespective of whether such errors, defects, or omissions in design result from acts or omissions of TEMPCO or of Purchaser or of some other third party. For products damaged in transit, claims must be filed with the common carrier. (All such claims should be filed immediately).



Note: Information in this catalog was deemed correct at the time of printing. The policy of Tempco is one of continuous development and product improvement, and we reserve the right to modify specifications, designs and the terms of conditions of sale without prior notice. In the event of a conflict, the terms and conditions of sale appearing on the reverse side of the order acknowledgement shall prevail. Not responsible for typographical errors.

Other Trademarks that appear in this catalog:

Alumel[®] Hoskins Manufacturing Company

Ceran[®] Schott North America, Inc.

Chromalox[®] Chromalox, Inc.

Cronifer II[®], **Cronix**, **Aluchrom**[®] Thyssen Krup VDM

Chrome[®] Hoskins Manufacturing Company

Datatemp[®] Raytek

DME[®] DME Company

Electroloy[®], **Protoloy**[®] Molecu Wire Corp.

Fiberglas[®] Owens-Corning Corporation

Hastelloy[®] Haynes International, Inc.

Incoe[®] Incoe Corporation

Incoloy[®] INCO Alloys International, Inc.

Inconel[®] INCO Alloys International, Inc.

Kapton[®] DuPont Co.

MWS[®] MWS Wire Industries

Nichrome[®] Driver-Harris

Nikrothal[®] Kanthal

Resistohm[®] Rescal S.A.S.

Stablohm[®] California Fine Wire Co.

Teflon[®] DuPont Co.

Tophet[®] Carpenter Technology Corp.

Twist-Lock[®] Harvey Hubbel Inc.

VELCRO[®] Velcro Industries B.V.

Watlow[®] Watlow Electric Mfg. Co.

Tempco Registered Trademarks

Accu-Ohm [®]	RTD
Arctic Cast [®]	Air Heat-Cool System
Beam-A-Temp [™]	Infrared Thermometer
Cool TO-THE Touch [™]	Finned Cast-In Heater with SS Shroud
Duraband [®]	Mica Band Heater
E-Mitter [®]	Ceramic Infrared Heater
Gamma [®] Series	Dual Sleeve Mini-Coil Heater
Gemini [®]	Medium Wave Infrared Heater
Hi-Density [®]	Cartridge Heater
Igloo [™]	Ceramic Terminal Cover
KTE [™] , KTG [™]	High Intensity Medium Wave Quartz Mini-Tube Infrared E-Mitters
Maxiband [®]	Tubular Element Band Heater
Maxistrip [®]	Tubular Element Strip Heater
Mi-Plus [®]	Mineral Insulated Band Heater
Mightyband [™]	Mineral Insulated Coil Heater with built-in-thermocouple
Mightybooster [™]	Water Circulation Heater
MX [™]	Runnerless Molding Controls
Pennybottom [™]	Cartridge Heater
Pronto [®] Service Logo	Expedited Shipment Program
TEC [™]	Temperature Controllers
TEMPCO [®]	Tempco Electric Heater Corporation
TEMPCO [®] Logo	Tempco Electric Heater Corporation
TEMPCO-PAK [®]	Mineral Insulated Cable
Terminator [®] Program Logo	Custom Cartridge Heaters from Stock
Universal 2000 [®]	Tubular Radiant Heater
VS Glow [®]	Infrared Heater
Visionary Solutions [™]	



Fermin Adames Sr. — A True Patriot

Fermin was a man of many talents. He was of course an entrepreneur, engineer, and mentor who spent a part of each day visiting every department at Tempco. He was the ultimate hands-on company president, always making sure we were taking care of our customers.

But to really know who Fermin was, and what was in his heart, one need look no further than the three paintings he commissioned. After immigrating to the US from Mexico in his late teens, Fermin developed a great love of the United States and the many freedoms we enjoy. After the terrorist attacks on September 11, 2001 he commissioned the first painting, titled “This Land is Your Land.” In this painting one or more landmarks from each of the fifty states and the District of Columbia are depicted. The Twin Towers of the World Trade Center are ghosted near the top in front of the American Flag.

The second painting, “Nativity,” depicts a Christmas scene in the small town of Nativity. The inspiration for this painting was the unfortunate political correctness prompting many to replace the word “Christmas” with the word “Holiday,” changing Christmas cards and Christmas trees into Holiday cards and Holiday trees. Christmas is a Christian holiday celebrating the birth of Jesus. As Fermin would say “It is what it is.” Fermin believed people of every religion should be able to celebrate their important days without others changing their meaning.

The third painting, “Defenders of Our Freedom,” was commissioned to honor the men, women and animals (dogs and horses) who have served in the armed forces, winning and preserving our freedoms. Fermin was a veteran and felt a special respect for those who put everything on the line, including their lives, for all of us.

On all three paintings Fermin worked closely with artist Stephen P. Ohlrich on the content and layout of the pieces. The first painting became the back cover of our Visionary Solutions catalog from 2005 to 2011. “Nativity” became the Tempco Christmas Card for 2006. The final painting, “Defenders of Our Freedom,” is on the back cover of this, our 40th Anniversary catalog.

Anyone who ever met Fermin will never forget him. It was an honor and a privilege to work with him.



“This Land is Your Land”



“Nativity”