



Table Of Contents

Pictorial Index	A-41	Sleeving, Armor Cable, Wire Braid	15-14
High Temperature Lead Wire	15-2	High Temperature Electrical Plugs	15-14
PTFE Lead Wire	15-3	Plugs and Terminal Boxes	15-15
Thermocouple Wire	15-4	Insulation Blankets	15-16
High Temperature Wire Harness	15-5	Heater Accessories — Electrical Tape & Terminal Lugs	15-18
Resistance Wire & Ribbon	15-6	Irreversible Temperature Strips & Indicators	15-18
Ceramic Terminal Blocks & High Temperature Wire Nuts	15-10		
Ceramic Heater Accessories	15-13		

Accessories

15
section



High Temperature Lead Wire

High Temperature Type MG (550°C), Type MG (450°C) and Type TGGT (250°C) Lead Wire



All of Tempco's High Temperature Lead Wires are designed for:

- Internal wiring for commercial and industrial heating products
- Heaters
 - Heat treating furnaces and kilns
 - Commercial food service equipment
 - Oven Wiring

Stock Lead Wire

Type MG – 600 Volt, 550°C (1022°F), UL 5400

Insulation Type – Mica/Glass (MG) Composite

Conductor Material – Nickel Clad Copper (NCC)
(27% Nickel by weight)



Wire Gauge	Nominal OD (in)	Stranding Num./Ga.	Maximum Amps @40°C	Feet per Spool	Part Number	Feet per Spool	Part Number	Feet per Spool	Part Number	Feet per Spool	Part Number
18	0.124	16/30	23	100	LDWR-1163	250	LDWR-1168	500	LDWR-1173	1000	LDWR-1178
16	0.138	26/30	30	100	LDWR-1164	250	LDWR-1169	500	LDWR-1174	1000	LDWR-1179
14	0.158	41/30	45	100	LDWR-1165	250	LDWR-1170	500	LDWR-1175	1000	LDWR-1180
12	0.182	65/30	56	100	LDWR-1166	250	LDWR-1171	500	LDWR-1176	1000	LDWR-1181
10	0.212	105/30	75	100	LDWR-1167	250	LDWR-1172	500	LDWR-1177	1000	LDWR-1182

Stock Lead Wire

Type MG – 600 Volt, 450°C (842°F), UL 5335/5107

Insulation Type – Mica/Glass (MG) Composite

Conductor Material – Nickel Clad Copper (NCC)
(27% Nickel by weight)



Wire Gauge	Nominal OD (in)	Stranding Num./Ga.	Maximum Amps @40°C	Feet per Spool	Part Number	Feet per Spool	Part Number	Feet per Spool	Part Number	Feet per Spool	Part Number
18	0.115	16/30	23	100	LDWR-1088	250	LDWR-1098	500	LDWR-1142	1000	LDWR-1152
16	0.134	26/30	30	100	LDWR-1089	250	LDWR-1099	500	LDWR-1143	1000	LDWR-1153
14	0.143	41/30	45	100	LDWR-1090	250	LDWR-1100	500	LDWR-1144	1000	LDWR-1154
12	0.166	65/30	56	100	LDWR-1091	250	LDWR-1101	500	LDWR-1145	1000	LDWR-1155
10	0.203	105/30	75	100	LDWR-1092	250	LDWR-1102	500	LDWR-1146	1000	LDWR-1156

Stock Lead Wire

Type TGGT – 600 Volt, 250°C (482°F), UL 5256

Insulation Type – Teflon®/Glass/Glass/Teflon® (TGGT)

Conductor Material – Nickel Plated Copper (NPC)
(2% Nickel by weight)



Wire Gauge	Nominal OD (in)	Stranding Num./Ga.	Maximum Amps @40°C	Feet per Spool	Part Number	Feet per Spool	Part Number	Feet per Spool	Part Number	Feet per Spool	Part Number
18	0.094	19/30	20	100	LDWR-1093	250	LDWR-1103	500	LDWR-1147	1000	LDWR-1157
16	0.103	26/30	26	100	LDWR-1094	250	LDWR-1104	500	LDWR-1148	1000	LDWR-1158
14	0.118	41/30	39	100	LDWR-1095	250	LDWR-1105	500	LDWR-1149	1000	LDWR-1159
12	0.136	65/30	54	100	LDWR-1096	250	LDWR-1106	500	LDWR-1150	1000	LDWR-1160
10	0.174	105/30	73	100	LDWR-1097	250	LDWR-1107	500	LDWR-1151	1000	LDWR-1161



Type PTFE (200°C/392°F) Lead Wire



Stock Lead Wire

Type PTFE – 300 Volt, 200°C (392°F) UL 1180

Insulation Type – PTFE

Conductor Material – Silver Plated Copper (SPC)

Insulation Color: Red

Wire Gauge	Nominal OD (in)	Stranding Num./Ga.	Maximum Amps @40°C	Feet per Spool	Part Number
22	0.056	19/34	9.6	100	LDWR-1112
20	0.064	19/32	14	100	LDWR-1111
18	0.073	19/30	18	100	LDWR-1110
16	0.079	19/29	24	100	LDWR-1109
14	0.093	19/27	36	100	LDWR-1108
22	0.056	19/34	9.6	250	LDWR-1127
20	0.064	19/32	14	250	LDWR-1126
18	0.073	19/30	18	250	LDWR-1125
16	0.079	19/29	24	250	LDWR-1124
14	0.093	19/27	36	250	LDWR-1123

Insulation Color: White

Wire Gauge	Nominal OD (in)	Stranding Num./Ga.	Maximum Amps @40°C	Feet per Spool	Part Number
22	0.056	19/34	9.6	100	LDWR-1117
20	0.064	19/32	14	100	LDWR-1116
18	0.073	19/30	18	100	LDWR-1115
16	0.079	19/29	24	100	LDWR-1114
14	0.093	19/27	36	100	LDWR-1113
22	0.056	19/34	9.6	250	LDWR-1132
20	0.064	19/32	14	250	LDWR-1131
18	0.073	19/30	18	250	LDWR-1130
16	0.079	19/29	24	250	LDWR-1129
14	0.093	19/27	36	250	LDWR-1128

Insulation Color: Black

Wire Gauge	Nominal OD (in)	Stranding Num./Ga.	Maximum Amps @40°C	Feet per Spool	Part Number
22	0.056	19/34	9.6	100	LDWR-1122
20	0.064	19/32	14	100	LDWR-1121
18	0.073	19/30	18	100	LDWR-1120
16	0.079	19/29	24	100	LDWR-1119
14	0.093	19/27	36	100	LDWR-1118
22	0.056	19/34	9.6	250	LDWR-1137
20	0.064	19/32	14	250	LDWR-1136
18	0.073	19/30	18	250	LDWR-1135
16	0.079	19/29	24	250	LDWR-1134
14	0.093	19/27	36	250	LDWR-1133



Note: Recommended Maximum Amperage is based on an Ambient Temperature of 40°C (104°F) and not more than three current carrying conductors in a raceway/conduit or bundled and directly buried. For de-rating factors for higher ambient temperatures consult Tempco's engineering data on page 16-10. For more information consult the National Electrical Code, Articles 310-15 through 310-84.

NOTE: For nickel wire conductor and other high temperature lead wire—consult Tempco.



Thermocouple Wire

ANSI Type J and K Duplex Thermocouple Wire — Stocked on 100 and 250 Foot Spools

Can be used for manufacturing thermocouple assemblies or as hook up wire between a thermocouple assembly and display instrumentation or a temperature control. The calibration is guaranteed to the full temperature range of the thermocouple type.



TC Type	Wire Type	Insulation	Insulation Temperature Limits (°F/°C)	Nominal Overall Dimensions (inches)	Part Number	
					100 Foot Spool	250 Foot Spool
J	20 Gauge Solid	Fiberglass	900/482	.060 × .106	TCWR-1028	TCWR-1032
J	20 Gauge Stranded	Fiberglass	900/482	.066 × .118	TCWR-1033	TCWR-1035
J	24 Gauge Solid	Fiberglass	900/482	.048 × .082	TCWR-1037	TCWR-1069
J	24 Gauge Stranded	Fiberglass	900/482	.048 × .082	TCWR-1038	TCWR-1070
J	20 Gauge Stranded	Fiberglass with SS overbraid	900/482	.088 × .140	TCWR-1047	TCWR-1051
J	20 Gauge Solid	FEP Teflon®	400/204	.068 × .116	TCWR-1060	TCWR-1062
J	24 Gauge Stranded	Fiberglass with SS overbraid	900/482	.074 × .100	TCWR-1048	TCWR-1052
K	20 Gauge Solid	Fiberglass	900/482	.060 × .116	TCWR-1025	TCWR-1029
K	20 Gauge Stranded	Fiberglass	900/482	.066 × .118	TCWR-1034	TCWR-1036
K	24 Gauge Solid	Fiberglass	900/482	.044 × .074	TCWR-1039	TCWR-1071
K	24 Gauge Stranded	Fiberglass	900/482	.050 × .082	TCWR-1040	TCWR-1072
K	20 Gauge Stranded	Fiberglass with SS overbraid	900/482	.088 × .140	TCWR-1049	TCWR-1053
K	20 Gauge Solid	FEP Teflon®	400/204	.068 × .116	TCWR-1061	TCWR-1063
K	24 Gauge Stranded	Fiberglass with SS overbraid	900/482	.074 × .100	TCWR-1050	TCWR-1054

ANSI Type JX and KX Thermocouple Extension Wire — Stocked on 100 and 250 Foot Spools

Due to its cost advantage thermocouple extension wire is used to make the connection between the thermocouple assembly and the measuring instrument, especially when long distances are involved. Thermocouple extension wire has approximately the same characteristics as thermocouple wire but its accuracy is guaranteed over a limited temperature range.

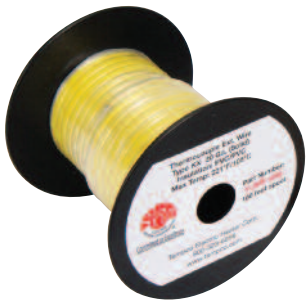

TC Type	Wire Type	Insulation	Insulation Temperature Limits (°F/°C)	Nominal Overall Dimensions (inches)	Part Number	
					100 Foot Spool	250 Foot Spool
JX	20 Gauge Solid	PVC	221/105	.092 × .154	TCWR-1027	TCWR-1031
JX	20 Gauge Stranded	PVC	221/105	.098 × .166	TCWR-1041	TCWR-1073
JX	24 Gauge Solid	PVC	221/105	.080 × .130	TCWR-1042	TCWR-1074
JX	24 Gauge Stranded	PVC	221/105	.084 × .138	TCWR-1043	TCWR-1075
JX	20 Gauge Solid	PVC with Shield & Drain	221/105	.169 Diameter	TCWR-1055	TCWR-1057
KX	20 Gauge Solid	PVC	221/105	.092 × .154	TCWR-1026	TCWR-1030
KX	20 Gauge Stranded	PVC	221/105	.098 × .166	TCWR-1044	TCWR-1076
KX	24 Gauge Solid	PVC	221/105	.080 × .130	TCWR-1045	TCWR-1077
KX	24 Gauge Stranded	PVC	221/105	.084 × .138	TCWR-1046	TCWR-1078
KX	20 Gauge Solid	PVC with Shield & Drain	221/105	.169 Diameter	TCWR-1056	TCWR-1058

Tempco's Thermocouple Wire and Extension Wire is supplied to meet Standard Tolerances of ANSI Circular MC96.1-1982.

For Thermocouple Wire Types and Special Limits/Tolerances not shown, refer to catalog pages 14-102 through 14-113 in the Temperature Sensors section.



High Temperature Wire Harness

High Temperature Wire Harness

Tempco's High Temperature Ceramic Insulated Wire Harnesses are designed from the ground up, starting with specially selected High Temperature Alloy Wire chosen for its ability to carry the rated current at the required temperature and provide long life.

- Ceramic beads are used for making turns and to provide flexibility at the terminal area.
- Solid ceramic pieces are used for straight runs.
- Ceramic terminal blocks are used for lead connections.

Ordering Information

Send all requirements, drawings or samples to Tempco for a fully detailed quote proposal that will meet your requirements. **Standard lead time is typically 2 weeks.**

Are You Having Problems With Your Wire Harnesses In High Temperature Applications?

Tempco has the design experience in the plastics industry and the manufacturing capability to handle your OEM requirements for many types of wire harness.

Due to our many years of manufacturing electric heaters, we are very familiar with the problems high temperature environments can cause to wiring and connectors.

We have the solutions to your difficult wiring applications!

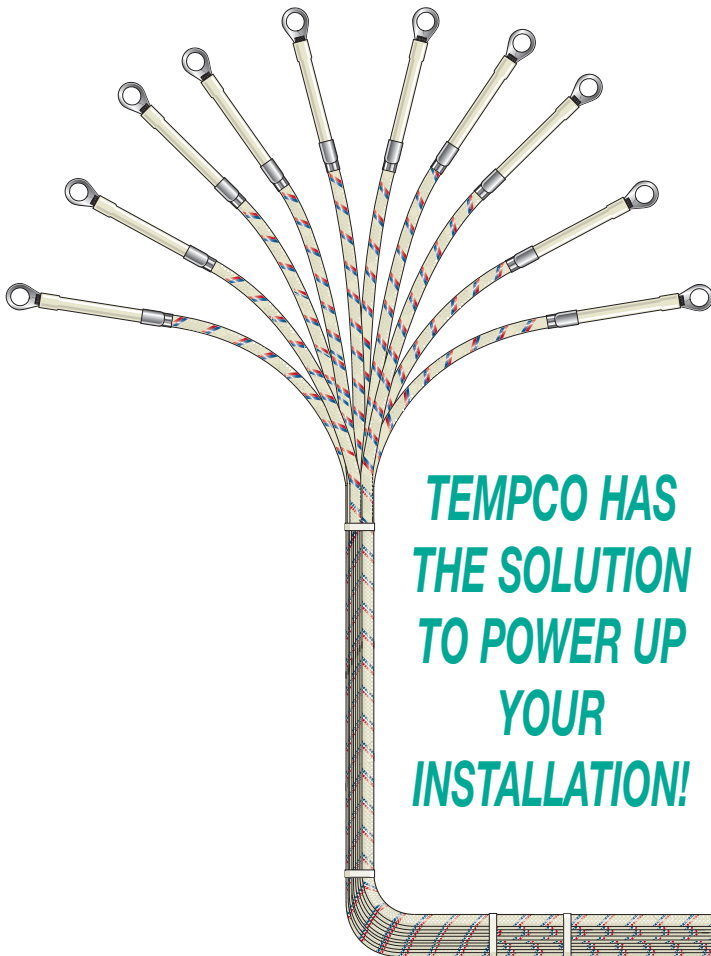

TEMPCO HAS THE SOLUTION TO POWER UP YOUR INSTALLATION!

Applications

- * Injection Molding Barrel
- * Plastic Extrusion Barrel
- * Aircraft Industry Composite Resin Lamination
- * Food Service Equipment
- * Furnaces
- * Ovens
- * Heat Treatment
- * Foundry Industry

Services Rendered

- * Custom Harness Manufacturing
- * Contract Assembly & Manufacturing
- * Automatic Cut & Strip
- * Wire Processing
- * Automatic & Hand Termination
- * Wire Bundling: Fiberglass Tape, Metal Strapping, Tie Wraps
- * Individual Wire ID Markings

Materials Used

- * Specially Selected High Temperature Conductors
- * UL and CSA Rated Wire
- * High Temperature Insulation
- * 600-Volt Gated Insulation
- * Sleeving and Tubing
- * Armor and Braid
- * UL and CSA Rated Connectors
- * Multi-Pin Connectors

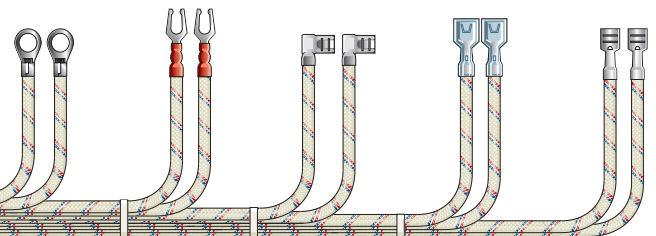



Resistance Wire

Resistance Wire

TEMPCO stocks a large amount of resistance wire that is required in our own manufacturing. We have made this inventory available to you for use in applications such as industrial heating, kilns, process heating and small-scale manufacturing.

The resistance wire is offered both in round wire and ribbon.

Type A: Wire only 2190°F (1200°C)

Type C: Wire 2100°F (1150°C) Ribbon 2055°F (1125°C)

Type D: Wire only 2370°F (1300°C)

"A" Wire (Kanthal Nikrothal 80 or Equivalent)

Composition: 80% Nickel, 20% Chromium

Specific Resistance: 650 Ohms / circ. mil foot @ 68°F / 20°C

Maximum continuous

operating temperature: 2190°F / 1200°C

(element temperature in air)

Melting Point: 1400°C / 2552°F

Density: (lbs/in³): 0.304

Specific Gravity: 8.41

Resistance Tolerance: 8 ga. through 23 ga. ±3%, 24 ga. through 36 ga. ±5%, 37 ga. through 43 ga. ±8%



Note: To obtain the working temperature resistance, multiply the factor by the room temperature resistance.

Temp. °F	68	200	400	600	800	1000	1200	1400	1600	1800	2000
Temp. °C	20	93	204	315	427	538	649	760	871	982	1093
Factor	1.000	1.016	1.037	1.054	1.066	1.070	1.064	1.062	1.066	1.072	1.078

(These figures are given as a basis for engineering calculations and represent average material as supplied.)

Part Number	Gauge	Diameter	Resistance at 68°F/20°C ohms/ft.	Weight lb./1000 ft.	Length ft./lb.	Nominal Spool Weight	Standard Spool Size Code
RES-101-142	8	0.128	0.03967	46.7	21.4	24	—
RES-101-132	9	0.114	0.05001	37.0	27.0	24	—
RES-101-131	12	0.081	0.09907	18.5	54.1	24	—
RES-101-102	17	0.045	0.3209	5.80	172.4	6	D
RES-101-130	18	0.040	0.4062	4.59	217.9	10	D
RES-101-103	19	0.036	0.5015	3.64	274.7	9	D
RES-101-104	20	0.032	0.6347	2.90	344.8	10	D
RES-101-105	21	0.0285	0.8002	2.30	434.8	8	D
RES-101-106	22	0.0253	1.017	1.81	552.5	9	D
RES-101-107	23	0.0226	1.272	1.44	694.4	5	C
RES-101-108	24	0.0201	1.609	1.14	877.2	10	D
RES-101-109	25	0.0179	2.029	0.906	1104	5	C
RES-101-110	26	0.0159	2.571	0.715	1399	2	F
RES-101-111	27	0.0142	3.228	0.570	1754	2	F
RES-101-112	28	0.0126	4.090	0.449	2227	3.5	F
RES-101-113	29	0.0113	5.090	0.361	2770	3.5	F
RES-101-114	30	0.0100	6.500	0.283	3534	2.25	F
RES-101-115	31	0.0089	8.206	0.224	4465	2.25	F
RES-101-116	32	0.0080	10.16	0.181	5525	2.5	F
RES-101-117	33	0.0071	12.90	0.143	6993	1.75	F
RES-101-118	34	0.0063	16.37	0.112	8929	2	B
RES-101-119	35	0.0056	20.72	0.0887	11,274	1	A
RES-101-120	36	0.0050	26.00	0.0707	14,144	1	A
RES-101-121	37	0.0045	32.09	0.0573	17,452	1	A
RES-101-122	38	0.0040	40.62	0.0452	22,124	1	A
RES-101-123	39	0.0035	53.06	0.0346	28,901	1	A
RES-101-124	40	0.0031	67.63	0.0272	36,765	1	A
RES-101-125	41	0.0028	85.98	0.0222	45,045	0.5	A
RES-101-126	42	0.0025	104.0	0.0177	56,497	0.3	A
RES-101-127	43	0.0022	128.5	0.0137	72,993	0.35	A



All Items Available from Stock

Cross Reference Chart

Kanthal	Hoskins	Driver-Harris	Carpenter	Rescal	Calfine Wire	Harrison	Thyssen Krup VDM	MWS Wire	Jelliff	Molecu
Nikrothal 60	Chromel C	Nichrome	Tophet C	Resistohm 60	Stablohm 675	HAI-NiCr 60	Cronifer II	MWS-675	Alloy C	Electroloy
Nikrothal 80	Chromel A	Nichrome V	Tophet A	Resistohm 80	Stablohm 650	Nichrome V	Cronix 80	MWS-650	Alloy A	Protoloy
Kanthal D	Alloy 815	—	Alchrome DK	Resistohm 135	Stablohm 812	Alferon 901	Aluchrom 5	—	—	—



"C" Wire (Kanthal Nikrothal 60 or Equivalent)

Composition: 60% Nickel, 16% Chromium, Fe balance
Specific Resistance: 675 Ohms / circ. mil foot @ 68°F / 20°C
Maximum continuous operating temperature: 2100°F / 1150°C
 (element temperature in air)

Density: (lbs / in³): 0.298
Specific Gravity: 8.25
Resistance Tolerance: 16 ga. through 23 ga. ±3%, 24 ga. through 36 ga. ±5%, 37 ga. through 44 ga. ±8%

Melting Point: 1350°C / 2462°F



Note: To obtain the working temperature resistance, multiply the factor by the room temperature resistance.

Temp. °F	68	200	400	600	800	1000	1200	1400	1600
Temp. °C	20	93	204	315	427	538	649	760	871
Factor	1.000	1.019	1.044	1.070	1.092	1.108	1.112	1.118	1.130

(These figures are given as a basis for engineering calculations and represent average material as supplied.)

Part Number	Gauge	Diameter	Resistance at 68°F/20°C ohms/ft.	Weight lb./1000 ft.	Length ft./lb.	Nominal Spool Weight	Standard Spool Size Code
RES-103-102	16	0.051	0.2595	7.20	138.9	8	D
RES-103-103	17	0.045	0.3333	5.72	174.8	10	D
RES-103-104	18	0.040	0.4219	4.53	220.8	10	D
RES-103-105	19	0.036	0.5208	3.60	277.8	8	D
RES-103-106	20	0.032	0.6592	2.86	349.7	10	D
RES-103-107	21	0.0285	0.8310	2.27	440.5	10	D
RES-103-108	22	0.0253	1.055	1.79	558.7	9	D
RES-103-109	23	0.0226	1.322	1.42	704.2	6	C
RES-103-110	24	0.0201	1.671	1.13	885.0	5	C
RES-103-111	25	0.0179	2.107	0.894	1119	5	C
RES-103-112	26	0.0159	2.670	0.705	1418	1.5	B
RES-103-113	27	0.0142	3.348	0.563	1776	5	C
RES-103-114	28	0.0126	4.251	0.443	2257	5	C
RES-103-115	29	0.0113	5.286	0.356	2809	5.25	C
RES-103-116	30	0.0100	6.750	0.279	3584	2	B
RES-103-117	31	0.0089	8.523	0.221	4525	3	F
RES-103-118	32	0.0080	10.55	0.179	5587	3	F
RES-103-119	33	0.0071	13.39	0.141	7092	2	B
RES-103-120	34	0.0063	17.00	0.111	9009	2	B
RES-103-121	35	0.0056	21.52	0.0875	11,429	0.75	A
RES-103-122	36	0.0050	27.00	0.0697	14,347	1	A
RES-103-123	37	0.0045	33.33	0.0565	17,699	0.75	A
RES-103-124	38	0.0040	42.19	0.0446	22,422	0.75	A
RES-103-125	39	0.0035	55.10	0.0342	29,240	1	A
RES-103-126	40	0.0031	70.24	0.0268	37,313	1	A
RES-103-127	41	0.0028	89.29	0.0219	45,662	0.25	A
RES-103-128	42	0.0025	108.0	0.0174	57,471	0.5	A
RES-103-129	43	0.0022	133.4	0.01422	70,320	0.5	A
RES-103-130	44	0.0020	168.8	0.0112	89,286	4	C

Ordering Information

1. Specify the part number and quantity in lbs.
2. Only full spools are available; re-spooling of smaller quantities is not available.
3. Tempco reserves the right to change spool sizes as required.
4. Tempco reserves the right to ship ±10% of the stated spool weight.



All Items Available from Stock

Standard Spool Dimensions

Spool Code	Flange		Barrel		Traverse		Bore ID	
	in	mm	in	mm	in	mm	in	mm
A	2.5	63	1.75	44	3	76	.62	16
B	3	76	1.75	44	3	77	.62	16
C	5	127	3	76	3.5	89	.62	16
D	6	152	3.5	89	3.5	89	.62	16
E	3.15	80	2	51	2.5	63	.62	16
F	3.87	98	2.37	59	3.12	79	.62	16
G	4.92	125	3.1	79	3.93	100	.62	16

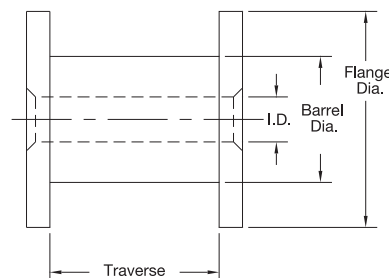



Resistance Wire

"C" Ribbon (Kanthal Nikrothal 60 or Equivalent)

Composition: 60% Nickel, 16% Chromium, Fe balance

Specific Resistance: 530 Ohms / circ. mil foot @ 68°F / 20°C

Maximum continuous operating temperature: 2055°F / 1125°C
(element temperature in air)

Melting Point: 1350°C / 2462°F

Density: (lbs/in³): 0.298

Specific Gravity: 8.25

Resistance Tolerance: ±5%



Note: To obtain the working temperature resistance, multiply the factor by the room temperature resistance.

Temp. °F	68	200	400	600	800	1000	1200	1400	1600
Temp. °C	20	93	204	315	427	538	649	760	871
Factor	1.000	1.019	1.044	1.070	1.092	1.108	1.112	1.118	1.130

(These figures are given as a basis for engineering calculations and represent average material as supplied.)



Part Number	Width	Thickness	Resistance at 68°F/20°C ohms/ft.	Weight lb./1000 ft.	Length ft./lb.	Nominal Spool Weight	Standard Spool Size Code
RES-105-101	1/64	0.0031	11.64	0.1581	6325	2	B
RES-105-102	1/64	0.0040	9.021	0.2046	4888	1	E
RES-105-103	1/64	0.0050	7.217	0.2559	3908	1.25	E
RES-105-104	1/64	0.0056	6.445	0.2865	3490	1.75	B
RES-105-105	1/64	0.0071	5.084	0.3626	2758	2	B
RES-105-106	1/64	0.0089	4.056	0.4555	2195	2.25	F
RES-105-107	1/32	0.0040	4.511	0.4090	2445	2.25	F
RES-105-108	1/32	0.0045	4.009	0.4604	2172	2.25	F
RES-105-109	1/32	0.0050	3.609	0.5118	1954	4	G
RES-105-110	1/32	0.0056	3.222	0.5730	1745	2.25	F
RES-105-111	1/32	0.0063	2.863	0.6442	1552	3	F
RES-105-112	1/32	0.0080	2.255	0.8181	1222	4	G
RES-105-113	1/32	0.0100	1.804	1.0276	973.1	4	G
RES-105-134	1/32	0.0113	1.597	1.1263	887.9	2.5	F
RES-105-114	1/16	0.0035	2.919	0.6494	1540	4	G
RES-105-115	1/16	0.0045	2.005	0.9208	1086	2	B
RES-105-116	1/16	0.0056	1.611	1.1461	872.5	8	D
RES-105-140	1/16	0.0063	1.432	1.2844	778.6	3	F
RES-105-117	1/16	0.0071	1.271	1.4524	688.5	3	F
RES-105-118	1/16	0.0080	1.128	1.6401	609.7	2.5	F
RES-105-119	1/16	0.0089	1.014	1.8179	550.1	1.25	E
RES-105-120	1/16	0.0100	0.9021	2.0452	488.9	4.5	G
RES-105-139	1/16	0.0126	0.7160	2.6577	376.3	2.5	F
RES-105-121	1/8	0.0035	1.459	1.2980	770.4	4	G
RES-105-122	1/8	0.0040	1.277	1.4835	674.1	1	E
RES-105-123	1/8	0.0050	1.022	1.8549	539.1	4	G
RES-105-138	1/8	0.0056	0.9124	2.0777	481.3	2.5	F
RES-105-124	1/8	0.0063	0.8107	2.5787	387.8	3.5	G
RES-105-125	1/8	0.0071	0.7198	2.9047	344.3	3	F
RES-105-126	1/8	0.0080	0.6386	3.2703	305.8	4	G
RES-105-137	1/8	0.0089	0.5070	3.6358	275.0	3	F
RES-105-127	1/8	0.0100	0.4511	4.0903	244.5	4	G
RES-105-136	1/8	0.0113	0.3992	4.4954	222.4	3.5	G
RES-105-135	1/8	0.0126	0.3580	5.3154	188.1	3	F

All Items Available from Stock

Cross Reference Chart

Kanthal	Hoskins	Driver-Harris	Carpenter	Rescal	Calfine Wire	Harrison	Thyssen Krup VDM	MWS Wire	Jelliff	Molecu
Nikrothal 60	Chromel C	Nichrome	Tophet C	Resistohm 60	Stablohm 675	HAI-NiCr 60	Cronifer II	MWS-675	Alloy C	Electroloy
Nikrothal 80	Chromel A	Nichrome V	Tophet A	Resistohm 80	Stablohm 650	Nichrome V	Cronix 80	MWS-650	Alloy A	Protoloy
Kanthal D	Alloy 815	—	Alchrome DK	Resistohm 135	Stablohm 812	Alferon 901	Aluchrom 5	—	—	—



“D” Wire (Kanthal Wire or Equivalent)

Composition: 22% Chromium, 4.8% Aluminum, Fe balance
Specific Resistance: 812 Ohms / circ. mil foot @ 68°F / 20°C
Maximum continuous operating temperature: 2370°F / 1300°C
 (element temperature in air)

Melting Point: 1500°C / 2730°F
Density: (lbs/in³): 0.262
Resistance Tolerance: 17 ga. through 23 ga. ±3%, 24 ga. through 36 ga. ±5%, 37 ga. ±8%



Note: To obtain the working temperature resistance, multiply the factor by the room temperature resistance.

Temp. °F	68	200	400	600	800	1000	1200	1400	1600	1800	2000	2200	2372
Temp. °C	20	93	204	315	427	538	649	760	871	982	1093	1204	1300
Factor	1.00	1.00	1.01	1.01	1.02	1.03	1.04	1.05	1.06	1.07	1.07	1.08	1.08

(These figures are given as a basis for engineering calculations and represent average material as supplied.)

Part Number	Gauge	Diameter	Resistance at 68°F/20°C ohms/ft.	Weight lb./1000 ft.	Length ft./lb.	Nominal Spool Weight	Standard Spool Size Code
RES-106-101	17	0.045	0.3964	5.07	197.2	10	D
RES-106-142	18	0.040	0.5000	4.01	249.4	10	D
RES-106-102	19	0.036	0.6304	3.18	314.5	5	C
RES-106-143	20	0.032	0.7950	2.53	395.3	1.75	C
RES-106-107	21	0.0285	1.003	2.01	497.5	8	D
RES-106-141	22	0.0253	1.264	1.58	632.9	6	C
RES-106-106	23	0.0226	1.594	1.26	793.7	35	—
RES-106-137	24	0.0201	2.010	1.00	1000	5	C
RES-106-109	25	0.0179	2.534	0.791	1264	5.5	C
RES-106-135	26	0.0159	3.196	0.624	1603	6	C
RES-106-136	27	0.0142	4.027	0.498	2008	5	C
RES-106-110	28	0.0126	5.082	0.392	2551	5	C
RES-106-103	29	0.0113	6.404	0.315	3175	4.25	C
RES-106-138	30	0.0100	8.071	0.247	4049	1.5	B
RES-106-111	31	0.0089	10.19	0.196	5102	1.5	B
RES-106-139	32	0.0080	12.85	0.158	6329	1.5	B
RES-106-105	33	0.0071	16.20	0.124	8065	4	C
RES-106-104	34	0.0063	20.43	0.0980	10,204	5	C
RES-106-140	35	0.0056	25.75	0.0774	12,920	5	C
RES-106-112	37	0.0045	40.95	0.0500	20,000	2	B

Ordering Information

1. Specify the part number and quantity in lbs.
2. Only full spools are available; re-spooling of smaller quantities is not available.
3. Tempco reserves the right to change spool sizes as required.
4. Tempco reserves the right to ship ±10% of the stated spool weight.



All Items Available from Stock

Standard Spool Dimensions

Spool Code	Flange		Barrel		Traverse		Bore ID	
	in	mm	in	mm	in	mm	in	mm
A	2.5	63	1.75	44	3	76	.62	16
B	3	76	1.75	44	3	77	.62	16
C	5	127	3	76	3.5	89	.62	16
D	6	152	3.5	89	3.5	89	.62	16
E	3.15	80	2	51	2.5	63	.62	16
F	3.87	98	2.37	59	3.12	79	.62	16
G	4.92	125	3.1	79	3.93	100	.62	16

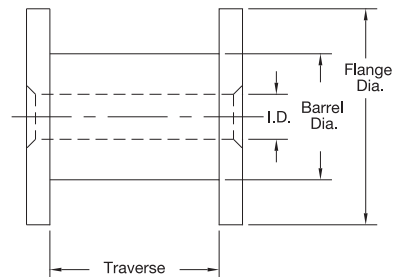



Ceramic Terminal Blocks & Connectors

Standard Ceramic Terminal Blocks for Internal Wiring

Used for wiring of heater power and thermocouple wiring in high temperature locations.

Design Features

- * **Maximum Voltage:** 600 VAC
- * **Maximum Current:** 20 Amp
- * **Maximum Temperature:** 450°C/842°F
- * **Wire Gauge:** 20 to 12 ga.
- * **Hardware:** Stainless Steel
- * **Terminals:** #8 Screw
- * **Body Material:** Steatite

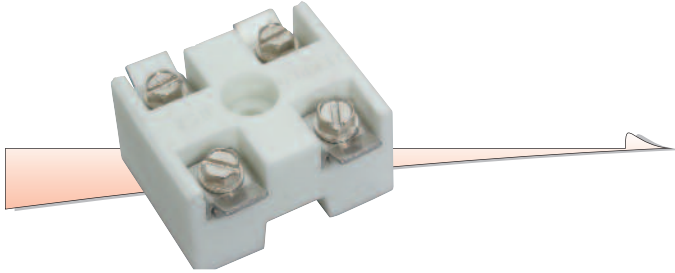

Part Number: EHD-108-101

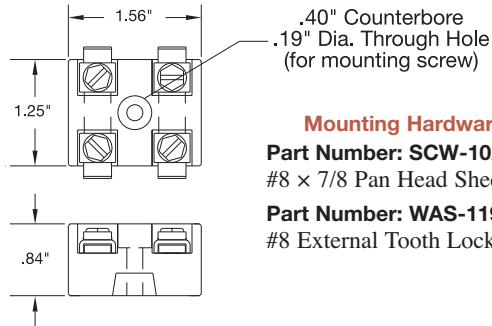

Mounting Hardware Supplied

Part Number: SCW-102-109
#8 x 7/8 Pan Head Sheet Metal Screw

Part Number: WAS-119-106
#8 External Tooth Lockwasher

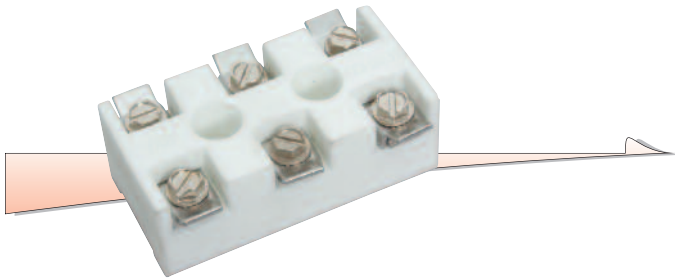

Part Number: EHD-108-121

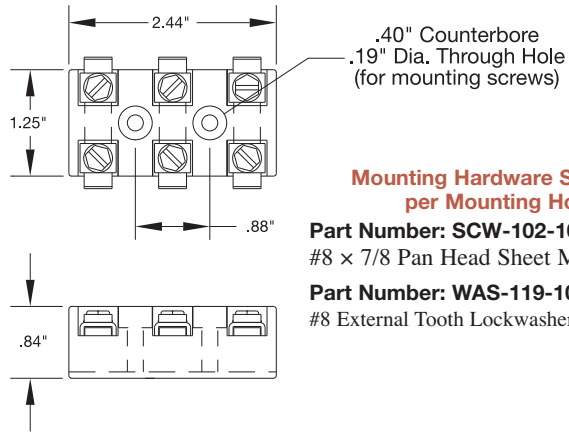

Mounting Hardware Supplied per Mounting Hole

Part Number: SCW-102-109
#8 x 7/8 Pan Head Sheet Metal Screws

Part Number: WAS-119-106
#8 External Tooth Lockwashers

Ceramic Wire Nut Connectors



Part Number	Wire Range (Solid or Stranded Wire)		Skirt Length	Opening ID	Outer Diameter
EHD-114-102	2#22	1#18 + 1#16	.687"	.250"	.406"
EHD-114-103	2#20	2#16	.750"	.312"	.484"
EHD-114-104	2#18	2#14	.843"	.406"	.531"
EHD-114-105	1#16 + 1#14	1#14 + 2#12	1.00"	.468"	.703"

SPECIFICATIONS

Material: Porcelain

Maximum Temperature Rating: 1200°F (645°C)

Maximum Voltage: 300V

EHD-114-102, EHD-114-103 and EHD-114-104 are UL Recognized (File E9809) and CSA Certified.

All Items Available from Stock

View Product Inventory @ www.tempco.com



Ceramic Terminal Blocks

Ceramic Terminal Blocks (Enclosed Terminals)

Used for wiring of heater power and thermocouple wiring in high temperature locations.

Design Features

- * **Maximum Voltage:** 380 VAC
- * **Maximum Current:** 30 Amp
- * **Maximum Temperature:** 240°C/464°F
- * **Wire Gauge:** 26 to 12 ga. stranded, 26-14 solid
- * **Screw:** M3, zinc plated steel
- * **Terminal Body:** Nickel plated brass
- * **Body Material:** Porcelain
- * **Agency Approvals:** CE & VDE



Part Number: EHD-108-116

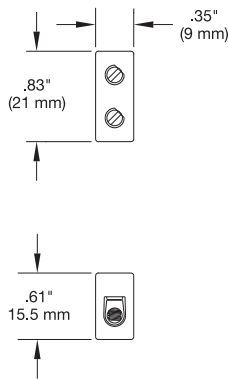

Part Number: EHD-108-117

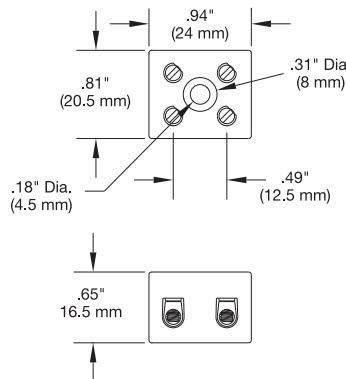

Part Number: EHD-108-118

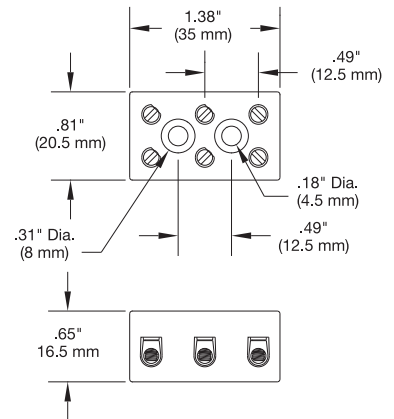

Ceramic Heavy Duty Terminal Blocks (Enclosed Terminals)

Used for wiring of heater power and thermocouple wiring in high temperature locations.

Design Features

- * **Maximum Voltage:** 600 VAC
- * **Maximum Current:** 50 Amp
- * **Maximum Temperature:** 200°C/392°F
- * **Wire Gauge:** 14 to 8 ga.
- * **Screw:** M4, zinc plated steel
- * **Terminal Body:** Nickel plated brass
- * **Body Material:** Porcelain
- * **Agency Approvals:** UL File #E69841

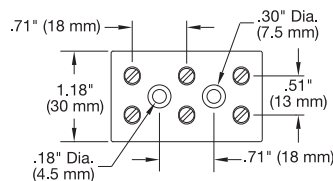
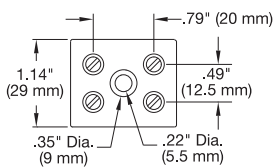

Part Number: EHD-108-114



Part Number: EHD-108-115

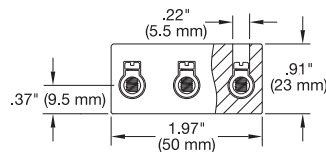
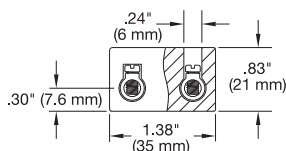

All Items Available from Stock





Ceramic Terminal Blocks

Heavy Duty High Temperature Ceramic Line Wiring Blocks (Exposed Terminals)

Used for interfacing heater assemblies, CRA housings and ARA arrays to external line wiring.

Design Features

- * **Maximum Voltage:** 500 VAC
- * **Maximum Current:** 44 Amp @ 104°F ambient
- * **Maximum Temperature:** 240°C/464°F
- * **Wire Gauge:** 18 to 8 ga.
- * **Terminal Screw:** M4, zinc-plated steel
- * **Body Material:** Steatite
- * **Agency Approvals:** None

Optional Terminal Hardware

Stainless Steel Flat Washer — Part Number: WAS-109-101

Spring Lock Washers — Part Number: WAS-118-108

Part Number: EHD-108-106

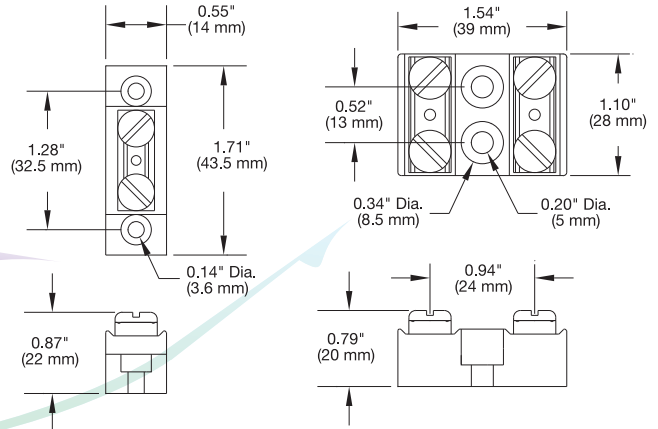

Part Number: EHD-108-107



Part Number: EHD-108-108

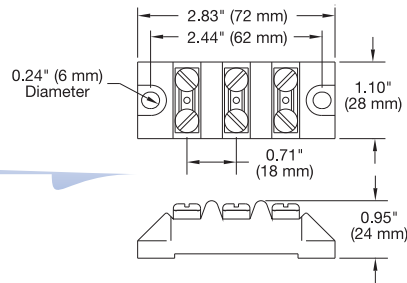
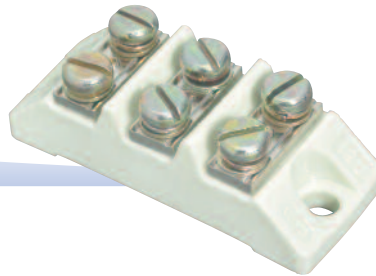

Part Number: EHD-108-109

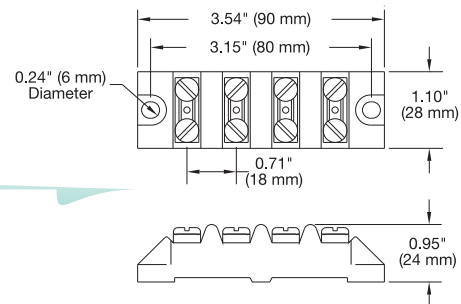

Part Number: EHD-108-105

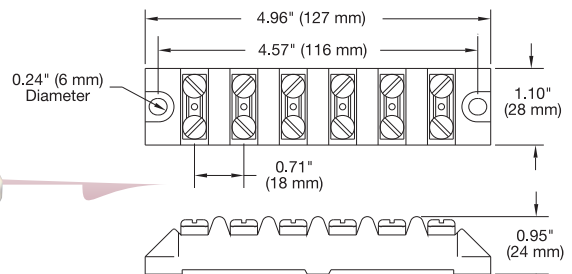

All Items Available from Stock



Stock Ceramic Accessories

Stock Ceramic Accessories

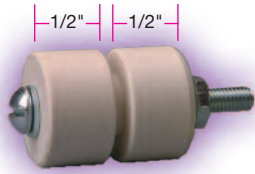

Screw Size:
10-32 x 1-3/4" long

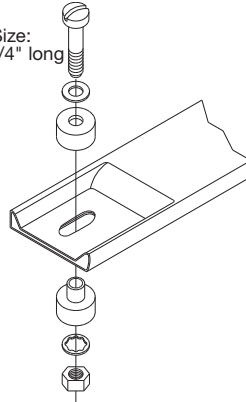

Secondary Insulating Bushings

Used to mount finned strip heaters in air heating applications. Also can be used when it is necessary to electrically isolate the heater from ground.

When Insulating Bushings are required, a 1/2" x 5/8" slot is substituted for the standard slot size (5/16" x 1/2").

Insulating Bushing Assembly

Part Number: **CERR-1001**

NOTE: Two assemblies are required for each heater.



When using secondary insulating bushings, the heater must be guarded to avoid any accidental contact. The guard must be electrically isolated from the heater and must be properly grounded.

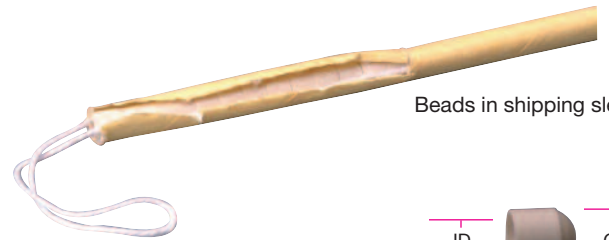

Beads in shipping sleeve

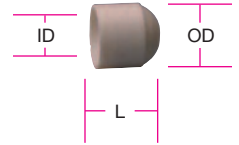

Ceramic Beads

Used to insulate bare lead wire at extremely high temperatures.

O.D. (in)	I.D. (in)	Length	Packaging	Sold By	Part Number
.110	.056	.110	67 beads/6" sleeve	Sleeve	CER-103-101
.170	.068	.170	86 beads/12" sleeve	Sleeve	CER-103-102
.200	.092	.200	36 beads/6" sleeve	Sleeve	CER-103-103
.200	.092	.200	bulk—loose	Piece	CER-103-104
.330	.124	.330	bulk—loose	Piece	CER-103-105
.203	.085	.203	bulk—loose	Piece	CER-103-108

Ceramic Covers for Insulating Screw Terminals

Used on the following heaters:

Mica Band • Ceramic Band • Mi-Plus® • Channel Strip • Finned Strip • Mica Strip

Provides an electrically safe environment on standard screw terminals.

Can be field retrofit or factory installed.

Igloo™ Ceramic Caps

Thread	Part Number
10-32	CER-102-101
10-24	CER-102-104
8-32	CER-102-105

Caps fit all Igloo™ bases below.

Ceramic Cap

Thread	Part Number
10-32	CER-102-101
10-24	CER-102-104
8-32	CER-102-105

All three caps fit conventional base.

Conventional Ceramic Base

Use with insulated terminals only.

Part Number: **CER-101-101**

Ceramic Cap CER-102-103 and Base CER-101-103 below are primarily used on cast-in .430 diameter tubular heating elements

Igloo™ Ceramic Bases

Type	Part Number
Double Port In-Line	CER-101-104
Double Port 90°	CER-101-106
Single Port	CER-101-107

All Items Available from Stock



Description

Ceramic Cap w/10-32 thread
Ceramic Base – .430 diameter

Part Number

CER-102-103
CER-101-103



Lead Wire Protection and Plugs

Lead Wire Protection and High Temperature Electrical Plugs

High Temperature Fiberglass Slewing



The fiberglass slewing is first annealed to remove all organic matter and then uniformly coated with highly abrasion-resistant silicone rubber, which provides an excellent secondary insulation for greater dielectric strength and added protection against abrasion and wire contamination.

Temperature Range: -70°C to 180°C (-94°F to 356°F)

Order by the foot: 50 ft. minimum

Trade Size	Nom. I.D. (in)	Part Number
24	.022	SLV-101-113
20	.034	SLV-101-112
16	.053	SLV-101-111
12	.085	SLV-101-110
10	.106	SLV-101-109
8	.133	SLV-101-108
5	.186	SLV-101-107
4	.208	SLV-101-106
3	.234	SLV-101-104
2	.264	SLV-101-102
0	.330	SLV-101-101
3/8"	.387	SLV-101-114

Flexible Armor Cable



Stainless Steel or Galvanized Steel

Used to protect lead wire against abrasion or physical damage in hazardous environments; provides protection from excessive flexing.

Order by the foot: 50 ft. minimum

I.D. (in)	O.D. (in)	Part Number		* Anti-Short Bushing (Plastic)
		Galv. Steel	Stainless Steel	
3/16	9/32	CAB-101-101	CAB-102-102	CAB-106-101
1/4	3/8	CAB-101-108	CAB-102-104	CAB-106-102
5/16	7/16	CAB-101-103	CAB-102-105	CAB-106-102
3/8	1/2	CAB-101-104	CAB-102-106	CAB-106-103
1/2	5/8	CAB-101-106	CAB-102-107	CAB-106-105

* Minimum Order 25 Pieces

Stainless Steel Braid Slewing



Used to protect lead wire against abrasion or physical damage in hazardous environments.

Order by the foot: 50 ft. minimum

I.D. (in)	Part Number
.078	CAB-105-101
.125	CAB-105-102
.172	CAB-105-103
.250	CAB-105-104
.375	CAB-105-105

All Items Available from Stock

Stock Quick-Disconnect High Temperature Electrical Plugs

Quick-Disconnect High Temperature Plugs provide the simplest and safest way to apply power to heater installations. The combination of plug and cup assembly along with armor cable covered leads eliminates all live exposed terminals or wiring that can be a potential hazard to employees or machines.

- * **Replace Exposed Terminals**
- * **Durable Cast Aluminum Body**
- * **High Temperature Ceramic Insulators**
- * **Solid Brass Contacts**
- * **Replace Exposed Lead Wires**
- * **Temperature Exposure Up to 300°C (572°F)**
- * **Available on Many Tempco Heater Products**

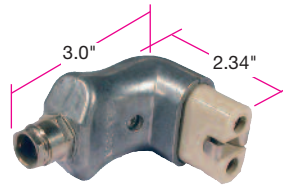

Right-Angle Plug

25 Amp—380 Volt Electrical Rating
Part Number: EHD-101-103

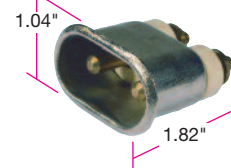

Cup Assembly

10 Amp—250 Volt Electrical Rating
Cutout size: 1.495" x .790"
Part Number: EHDR-1001



Straight Plug

25 Amp—380 Volt Electrical Rating
Part Number: EHD-101-102



Plugs can be prewired and fitted with armor cable or wire braid leads.

Part Number: assigned when ordered



Heavy Duty Quick-Disconnect Plugs and Matching Connectors (Cable Type)

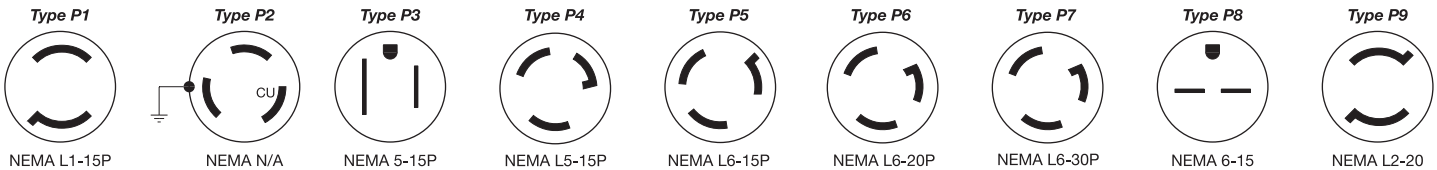
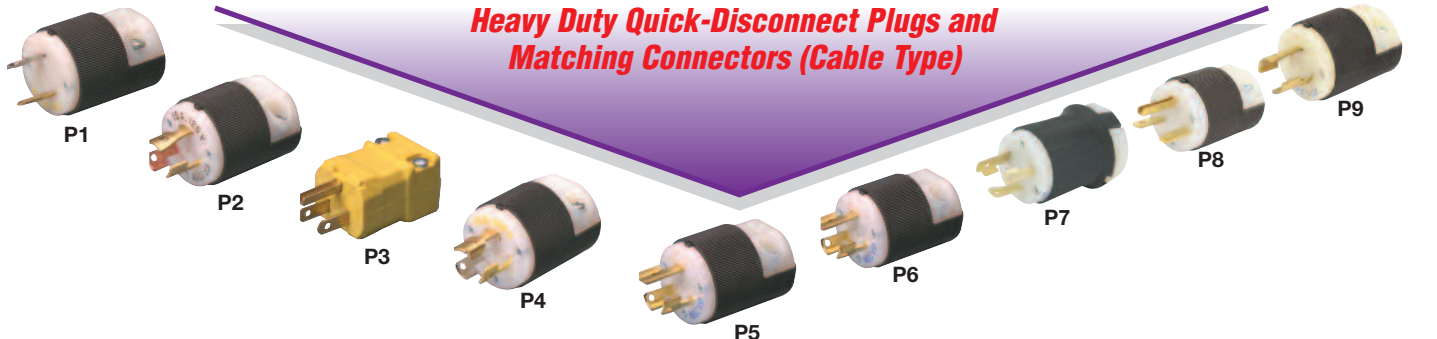

Reference	NEMA P or R	Amps	Volts	Plug Part No.	Connectors (Female) Part Number
P1 twist lock	L1-15	15A	125V	EHD-102-102	EHD-103-101
P2 twist lock	N/A	10A 15A	250V 125V	EHD-102-107	EHD-103-103
P3 straight	5-15	15A	125V	EHD-102-103	EHD-103-102
P4 twist lock	L5-15	15A	125V	EHD-102-113	EHD-103-104
P5 twist lock	L6-15	15A	250V	EHD-102-121	EHD-103-107
P6 twist lock	L6-20	20A	250V	EHD-102-122	EHD-103-150
P7 twist lock	L6-30	30A	250V	EHD-102-126	EHD-103-125
P8 straight	6-15	15	250V	EHD-102-114	EHD-103-139
P9 twist lock	L2-20	20A	250V	EHD-102-104	N/A



Notes: Type P2 twist lock plug is not listed by UL, and is recommended for replacement use only in existing installations.

Connectors are cable mount only.

General Purpose Terminal Boxes (Can be field retrofit or factory installed)

Housings that Fit — Mica Bands, Ceramic Bands, Mi-Plus® Bands and Mica Strip Heaters

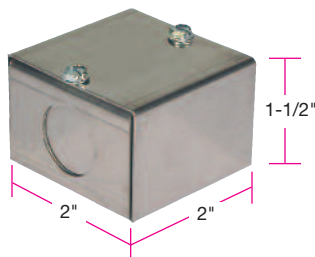

For use on Standard T3 Screw Termination with 10-32 studs.
Terminal mounting centers: 7/8"
Knockout: 1/2" conduit
Part Number: HSGR-1011

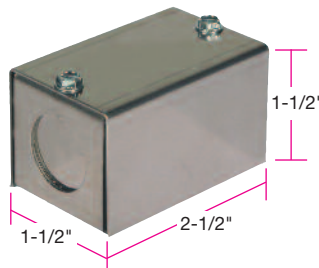

For use on Standard T2 Screw Termination with 10-32 studs.
Terminal mounting centers: 7/8"
Knockout: 1/2" conduit
Part Number: HSGR-1013

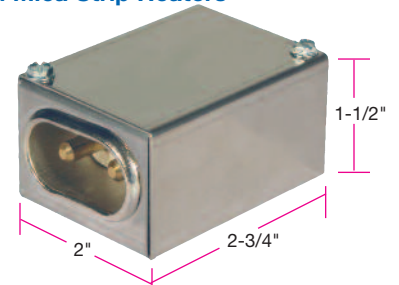

Box HSGR-1005 with EHDR-1001 cup assembly (see page 15-14).
For use on Standard T3 Screw Termination with 10-32 studs.
Terminal mounting centers: 7/8"
Part Number: EHDR-1002

Housings that Fit — Channel Strip and Finned Channel Strip Heaters

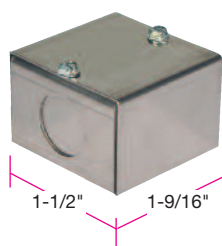

For use on Standard T3 Screw Termination with 10-32 studs.
Terminal mounting centers: 3/4"
Knockout: 1/2" conduit
Part Number: HSGR-1008

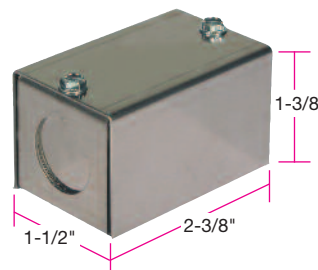

For use on Standard T2 Screw Termination with 10-32 studs.
Terminal mounting centers: 3/4"
Knockout: 1/2" conduit
Part Number: HSGR-1068

Other style boxes such as PVC, drawn aluminum or, explosion-proof are available.



Insulation Blankets

Insulation Blankets

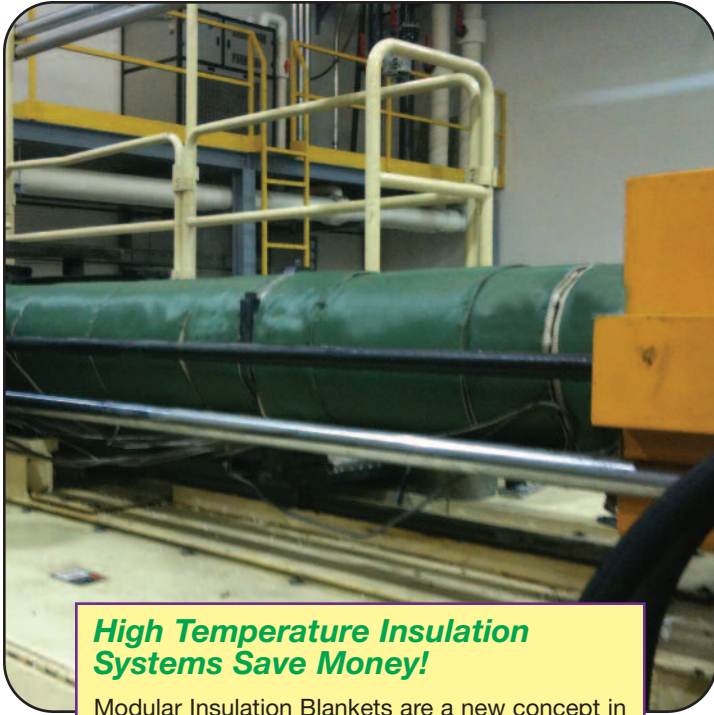

High Temperature Insulation Systems Save Money!

Modular Insulation Blankets are a new concept in insulation systems that will allow you to insulate most typical plastic molding machines with ease.

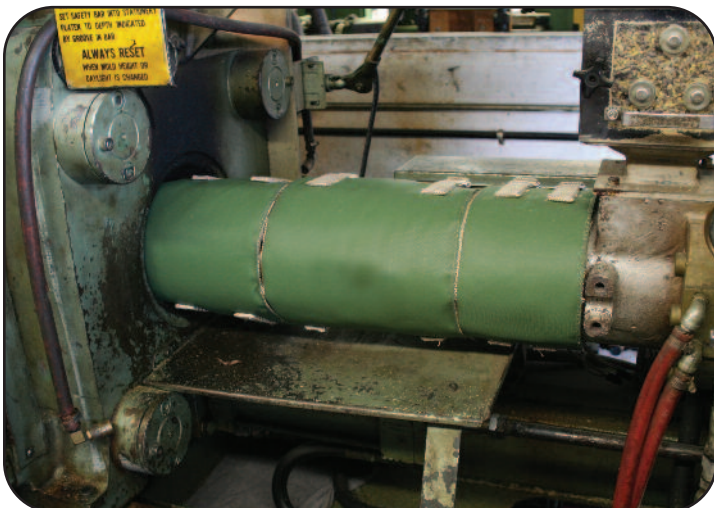
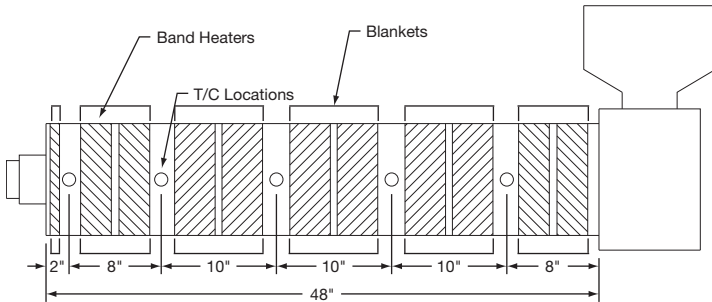

Tempco offers a line of Modular Insulating Blankets designed to contain the heat generated by industrial elements in various applications, thereby conserving energy and cooling the environment.

Simply measure the outside diameter of your heater bands and the width between thermocouples. The distance between thermocouples is critical because the modular blankets should be sized to fit between them. To insulate an 8" width, you would utilize two blankets, for instance, a 2" and 6" wide blanket.

Example (refer to the drawing)

- The length of the plastic injection machine barrel to insulate is 48".
- From the hopper end, the thermocouple breaks needed are at 8", 18", 28", 38", 46" and 48". This would yield insulation distances of 8", 10", 10", 10", 8", and 2" between the thermocouples.

For the (two) 8" distances, use two 4" blankets each.

For the (three) 10" distances use one 4" and one 6" blanket each.

For the 2" distance, use one 2" blanket.

**To summarize, the total requirement is: one 2" blanket
seven 4" blankets
three 6" blankets**

Typical Applications

- Injection Molding
- Extrusion Barrels and Blow Molding
- Pre-Heaters
- Hoppers and Driers
- Hot Oil Lines
- Manifolds
- Melt Pipe Dies and Adapters

SPECIFICATIONS

Hot Face/Inside Fabric

Material: Silica Fabric with Vermiculite
Thickness: .042"
Maximum Temperature: 1800°F (982°C) continuous

Cold Face/Outside Fabric

Material: PTFE-Impregnated Fiberglass Cloth
Thickness: .014"
Maximum Temperature: 550°F (288°C) continuous

Insulation

Material: Ceramic Fiber
Thickness: 1"
Maximum Temperature: 2300°F (1260°C)

Straps

Material: PTFE-Impregnated Fiberglass Cloth

Buckles

Material: Nickel-Plated steel wire with loose roller to allow for ease of tightening of straps



Note: When using insulation blankets it is recommended to derate the wattage of the heater bands by 20 to 25% to extend heater life and further reduce power consumption.



Energy Savings Using Insulation Blankets

Injection Molding Barrel Estimated Return on Investment

Estimated Initial Tonnage	Avg. KWh Investment	Avg. KWh Uninsulated	Payback Insulated	Estimated 3 Year Period - months	Savings
150	\$300	1.52	0.52	8.54	\$1,391.81
300	660	3.00	2.05	10.69	2,223.72
500	1,100	7.65	6.02	10.38	3,815.28
850	1,870	9.33	6.79	11.32	5,945.04
1000	2,200	11.35	8.12	10.48	7,560.00
1500	3,300	13.54	9.22	11.75	10,111.32

NOTE: The above information is to be used for comparisons only. Actual results in your plant on your injection molding machines may differ.

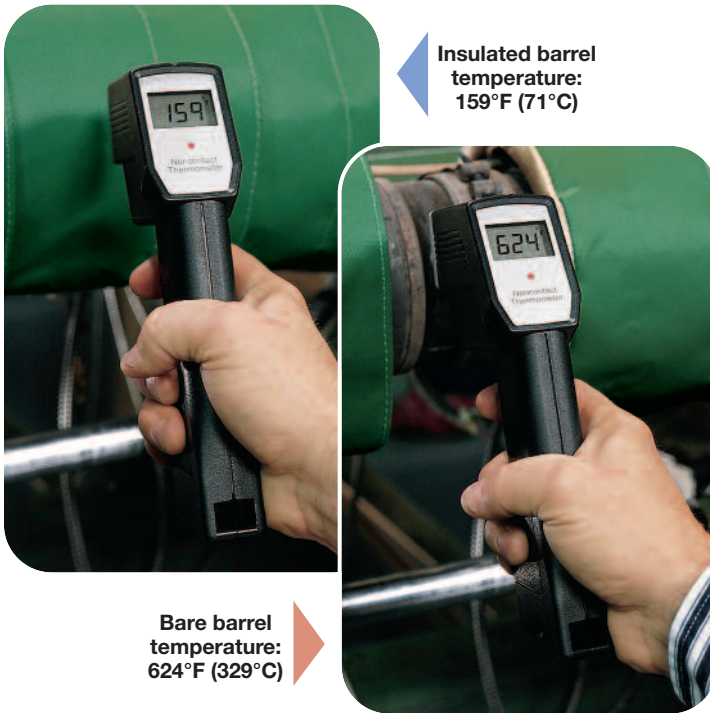

Standard (Non-Stock) Insulation Blankets

Inner Diameter	Width	Part Number	
		With 1" Overlap Flap	Without Overlap Flap
4"	2"	BLK00402	BLK10402
	4"	BLK00404	BLK10404
	6"	BLK00406	BLK10406
5"	2"	BLK00502	BLK10502
	4"	BLK00504	BLK10504
	6"	BLK00506	BLK10506
6"	2"	BLK00602	BLK10602
	4"	BLK00604	BLK10604
	6"	BLK00606	BLK10606
7"	2"	BLK00702	BLK10702
	4"	BLK00704	BLK10704
	6"	BLK00706	BLK10706
8"	2"	BLK00802	BLK10802
	4"	BLK00804	BLK10804
	6"	BLK00806	BLK10806
9"	2"	BLK00902	BLK10902
	4"	BLK00904	BLK10904
	6"	BLK00906	BLK10906
10"	2"	BLK01002	BLK11002
	4"	BLK01004	BLK11004
	6"	BLK01006	BLK11006
11"	2"	BLK01102	BLK11102
	4"	BLK01104	BLK11104
	6"	BLK01106	BLK11106
12"	2"	BLK01202	BLK11202
	4"	BLK01204	BLK11204
	6"	BLK01206	BLK11206

Ordering Information

Standard — After determining the diameter and width of the insulation blankets required, select the **Part Number** from the chart above that matches your requirements.

Custom Engineered/Manufactured — Custom Insulation Blankets can also be designed for your application in circumferential or flat applications. Please submit to Tempco your drawing or sketch to quote.

Standard lead time is Stock to 4 weeks.



Heater Accessories

Heater Accessories (Stock)



High Temperature Terminal Lugs

Order by the piece: 25 pc. minimum

Terminal Type	Screw Size	Wire Size Ga.	Temperature °F/°C	Part Number
Ring	#12	16-14	1200/649	TER-111-101
	#10	22-18	900/482	TER-110-117
	#10	16-14	1200/649	TER-110-104
	#10	16-14	900/482	TER-110-106
	#10	12-10	900/482	TER-110-111
	#8	22-18	900/482	TER-109-110
	#8	16-14	1200/649	TER-109-101
	#8	16-14	900/482	TER-109-104
Spade	#8	12-10	900/482	TER-109-106
	#10	22-18	900/482	TER-115-111
	#8/10	22-18	900/482	TER-115-112
	#8	16-14	900/482	TER-115-113

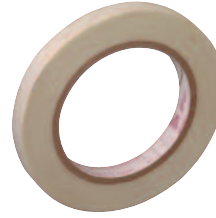

Fiberglass Tape

A superior pressure-sensitive adhesive tape consisting of fiberglass cloth impregnated with a thermosetting silicone.

Thickness: .007" **Length:** 36 yards
Maximum Temperature: 356°F (180°C)

Width	Part Number
1/2"	TAP-101-101
1/4"	TAP-101-102

Irreversible Temperature Strips and Indicators

SPECIFICATIONS

Material: Polyester for up to 160°C/320°F
 Polyimide for above 160°C/320°F

Accuracy: ± 1°C below 100°C/212°F
 ± 1% above 100°C/212°F

Pressure-Sensitive Adhesive:
 Double sided low tack adhesive up to 160°C/320°F

Label Color: Black printing on blue background

Temperature Reached:
 Indicated in change from white to black

5-Point "Clock" Multipoint Indicators

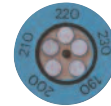

Size: 0.5" x 0.5"

Temperature Point (°F)	Part Number
140, 150, 160, 170, 180	NTS20180
190, 200, 210, 220, 230	NTS20230
240, 250, 261, 270, 280	NTS20280
290, 300, 310, 320, 330	NTS20330
340, 350, 360, 370, 380	NTS20380
390, 400, 410, 420, 435	NTS20435
450, 466, 480, 490, 500	NTS20500

NOTE: Ordered in packs of 10 temperature clock labels per pack.

Single Point Indicators



Size: 0.5" x 0.5"

Temperature Point °F	Temperature Point °C	Part Number
129	54	NTS30129
149	65	NTS30149
160	71	NTS30160
171	77	NTS30171
180	82	NTS30180
199	93	NTS30199
219	104	NTS30219
230	110	NTS30230
241	116	NTS30241
250	121	NTS30250
261	127	NTS30261
270	132	NTS30270
280	138	NTS30280
289	143	NTS30289
300	149	NTS30300

NOTE: Ordered in packs of 50 temperature indicators per pack.

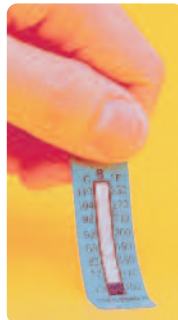

Size: 2" x 0.7"

Multi-Level Strip Indicators

Stock Items Are Shown In **RED**

Type	Temperature Points	Part Number
8 Level	°F: 100, 105, 110, 115, 120, 130, 140, 150 °C: 37, 40, 43, 46, 49, 54, 60, 65	NTS10150
8 Level	°F: 160, 170, 180, 190, 200, 210, 220, 230 °C: 71, 77, 82, 88, 93, 99, 104, 110	NTS10230
8 Level	°F: 240, 250, 260, 270, 280, 290, 300, 310 °C: 116, 121, 127, 132, 138, 143, 149, 154	NTS10310
8 Level	°F: 320, 330, 340, 350, 360, 370, 380, 390 °C: 160, 166, 171, 177, 182, 188, 193, 199	NTS10390
9 Level	°F: 400, 410, 420, 435, 450, 465, 480, 490, 500 °C: 204, 210, 216, 224, 232, 241, 249, 254, 260	NTS10500
5 Level	°F: 480, 490, 500, 536, 554 °C: 249, 254, 260, 280, 290	NTS10554

NOTE: Ordered in packs of 10 temperature strips per pack.